

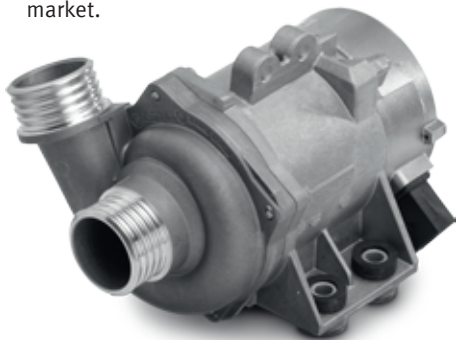

Warning about product fakes of the CWA 200 electrical coolant pump

Product: CWA 200 electrical coolant pump		Vehicles: BMW	
PIERBURG no.	Ref. no.	Vehicle applications	Engine
7.02851.20.8	11 51 7 521 584, 11 51 7 545 201, 11 51 7 546 994, 11 51 7 563 183, 11 51 7 586 924, 11 51 7 586 925	E60-E66, E70, E81-E89, E90-E93, F01-F25	N 52, N 53

It has come to our attention that there are product fakes of the CWA 200 electrical coolant pump originating from the Asian market.



View of product CWA 200 (original)

⚠ Attention: We expressly warn against the use of these product fakes.

None of the pumps in our possession fulfilled the requirements of the vehicle manufacturer. In the event of a failure of such a pump, the engine overheats and this can result in severe consequential damage.

👉 Note: For your safety, we take legal steps against any form of illegal import and the introduction to the market of product fakes.

On the following page you will find differentiating characteristics as well as an excerpt from the test report.

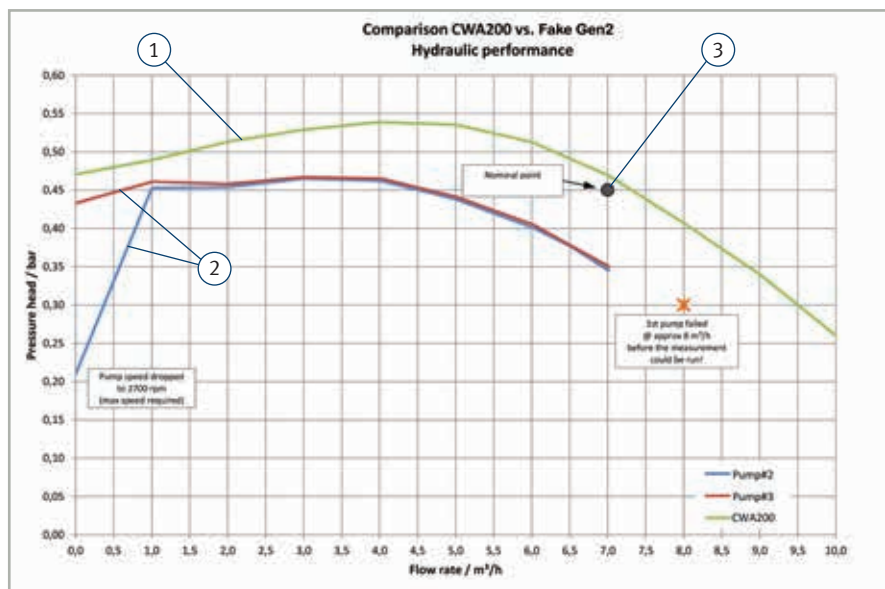

Comparative hydraulic measurement in the PIERBURG test lab (original document)
(1) PIERBURG CWA 200, (2) Counterfeits, (3) Nominal point of the vehicle manufacturer

Comparison of technical data		PIERBURG CWA 200	Counterfeit
Voltage range	[V]	8 to 16	10 to 15.5
Nominal pressure difference	[bar]	0.45	max. 0.4
Nominal volumetric flow	[m³/h]	7.0	max. 2.0
Nominal speed	[rpm]	4500	max. 3500
Ambient temperature range	[°C]	-40 to +140	no data



Technical findings

Excerpt from the technical findings of the test laboratory:

"The counterfeits do not meet the [...] required nominal point for volumetric flow (flow rate) and malfunction as soon as they are switched to higher performance ranges.

Particular areas of weakness are the electric motor and electronic components, which malfunction, completely fail and become irreparably damaged after just a short time under increased stress.

[...] the electronic components present considerable difficulties in the communication between the pump and vehicle control unit, meaning that correct operation is not possible.

Furthermore, the counterfeits do not have shielding for the electronics, resulting in disruption to other electrical circuits of the engine.

The pump fails and active cooling of the engine is no longer guaranteed. [...]

The installation of these counterfeits would represent gross negligence."

Differentiating characteristics

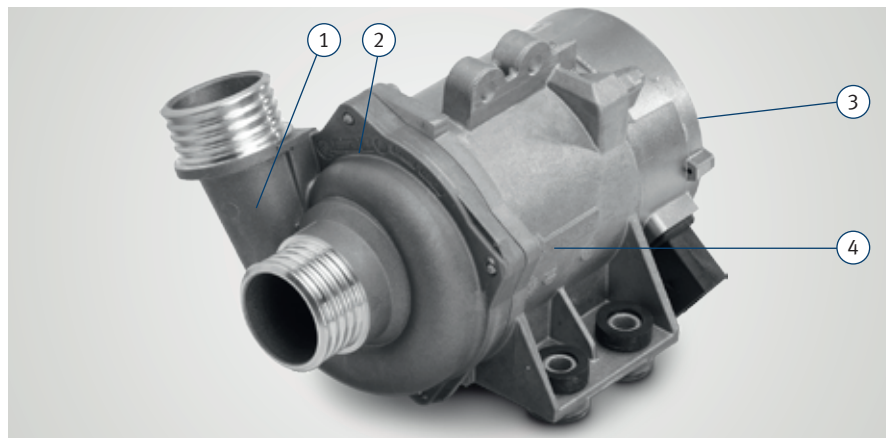

Original PIERBURG coolant pump

Counterfeit

