



Swirl flaps/Tumble flaps

What makes the difference?

PIERBURG manifolds, as used in modern Otto- and diesel vehicles, often have swirl or tumble flaps in their inlet ports.

Swirl flaps

Swirl flaps produce a swirl alongside the cylinder axle. They are used in diesel vehicles to improve the mixing of the fuel-air mixture at low engine speeds. For this purpose, the air is fed to each cylinder through two separate channels in the intake manifold. One of the two channels can be closed with a swirl flap. This creates a swirling of the fresh air. Better mixing reduces fuel consumption and pollutant emission. At higher engine speeds and torques, the swirl flap is opened to achieve a better filling level.

The swirl flaps are also opened at starting of the engine and in overrun condition.

Swirl flaps are also called "inlet duct cutoffs".

In the Opel Twinport engine, the swirl flap reduces the throttle losses during part-load operation.

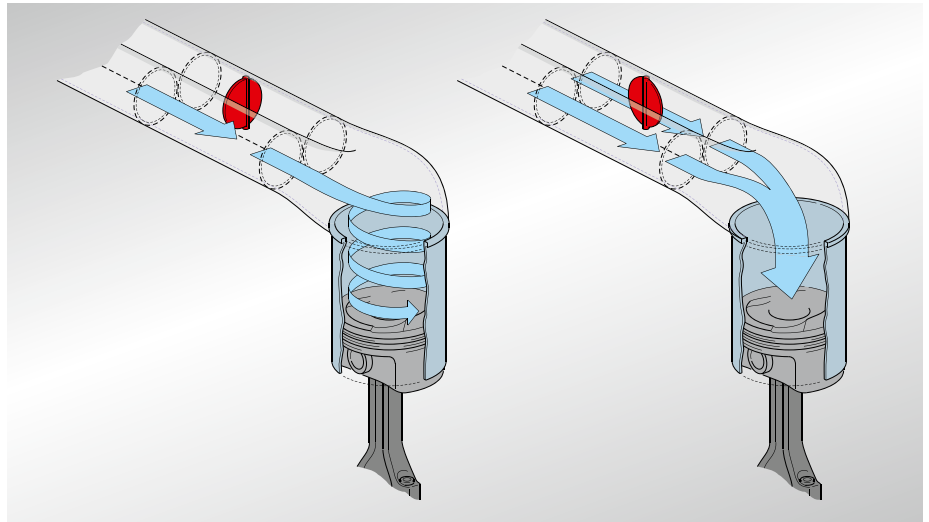

*Fig. 1: Swirl flap: swirl in axial direction of the piston
Left: part load, swirl flap closed, strong swirling
Right: full load, swirl flap open, high filling level*



*Two channels for each cylinder:
Swirl flaps (highlighted in red) in the PIERBURG intake manifold, e.g. in the Opel Astra J 1.7 CDTi*

The right of changes and deviating pictures is reserved. Assignment and usage, refer to the each case current catalogues, TecDoc CD respectively systems based on TecDoc.



Tumble flaps

Tumble flaps produce a swirl alongside the cylinder axle.

This is achieved by either dividing the air intake channel into two separate channels, of which one channel can be closed by the tumble flap (see image), or by turning one flap sideways into the air flow (see photo).

Tumble flaps are used in vehicles with petrol direct injection (e.g. in FSI engines) to realise a stratified charge. In the stratified charge operation, by means of this specifically produced air flow and a special geometry of the piston, the fuel-air mixture is agglomerated directly around the spark plug, and ignited.

Therefore, there is clean air in the marginal areas of the combustion chamber. The clean air serves as insulation during combustion and reduces heat loss.

Further reduction of consumption is achieved by dethrottling the engine.

At higher engine speeds and torques, the tumble flap is opened to achieve a better filling level. During this so-called homogenous operation, the engine functions like a conventional fuel injection engine, but with higher efficiency due to the higher compression.

This enables a reduction of fuel consumption in the low engine speed range, without sustaining losses of power or torque at higher engine speeds.

Tumble flaps are also called “charge-motion flaps”.

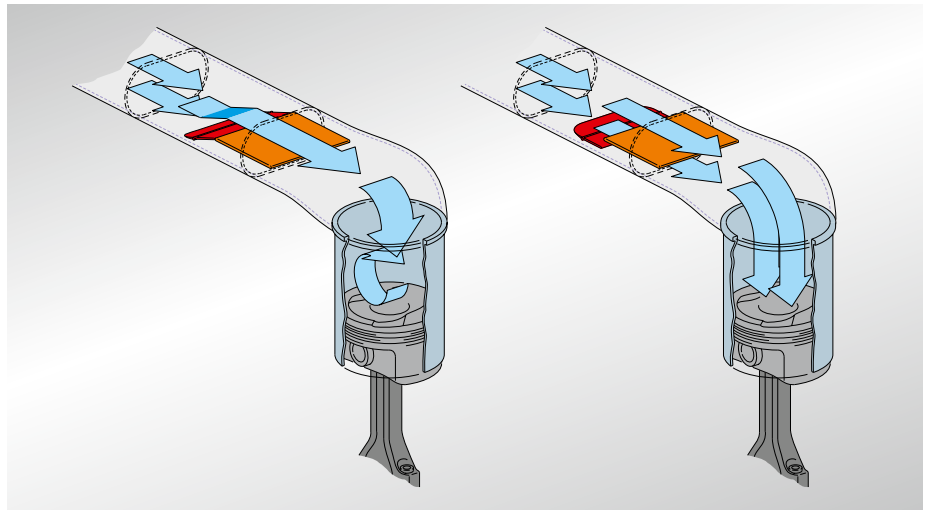

Tumble flap: swirl vertical to axial direction of the piston, Left: stratified charge; Right: homogenous operation



Tumble flaps (highlighted in red) in the PIERBURG intake manifold, e.g. in the Mercedes E-Class 500



Note:

Throttle losses/Dethrottling

A not completely opened throttle valve in the intake air system constricts the fresh air supply. This results in resistance which causes throttle losses. Every action taken to open the throttle flap (dethrottling) reduces the throttle losses and therefore fuel consumption.



KS pistons with special piston crown for stratified charge operation