



**MOTORSERVICE**  
RHEINMETALL AUTOMOTIVE

**BF spare parts**

**Maximum performance**

**under high load**



## Wide range of spare parts for diesel engines



### **Service life of three million kilometres, daily load of 30 tonnes.**

The drives of utility vehicles have to withstand particularly high stresses. The reliability of drive components is an absolute necessity to keep the total costs of ownership low.

Under the brand BF, Motorservice sells engine components of the highest quality which are designed for a long service life and efficient repairs.

[www.ms-motorservice.com](http://www.ms-motorservice.com)

### **Service is what drives us**

There's a reason that "service" is part of our name: It is a promise to our customers. Our logistics centres with a hall area of 40,000 m<sup>2</sup> and up to 7,000 pick positions per day therefore guarantee a high availability and immediate delivery. BF products impress as high-quality solutions for a repair based on the current market value and at market-oriented prices.

We also constantly analyse the worldwide use of utility vehicles and their failure rates and use this information to develop our spare parts range for the free aftermarket.

### **Cross-brand offer**

Our extensive product range covers engines from Volvo, Scania, Mercedes-Benz, MAN, Iveco, Deutz, DAF, Cummins and many other engine manufacturers.



# Reliable performance



## Product range

- 1 Cylinder head
- 2 Rocker arm
- 3 Valve-spring + accessories
- 4 Cylinder head bolt
- 5 Oil injection jet
- 6 Starter ring gears
- 7 Fly wheel
- 8 Oil pump
- 9 Crankshaft
- 10 Connecting rod bolt
- 11 Connecting rod
- 12 Crankcase
- 13 Vibration damper (without illustration)
- 14 Camshaft
- 15 Tappet
- 16 Valve push rod
- 17 Water pump

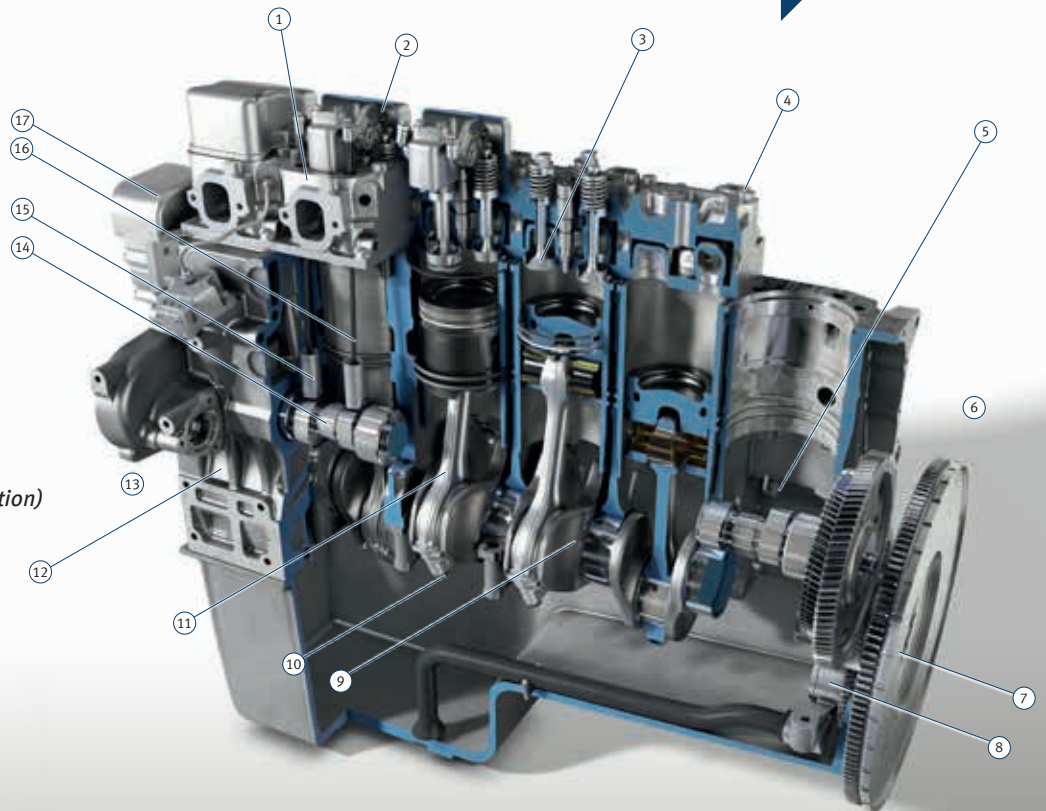

# Engine components and service

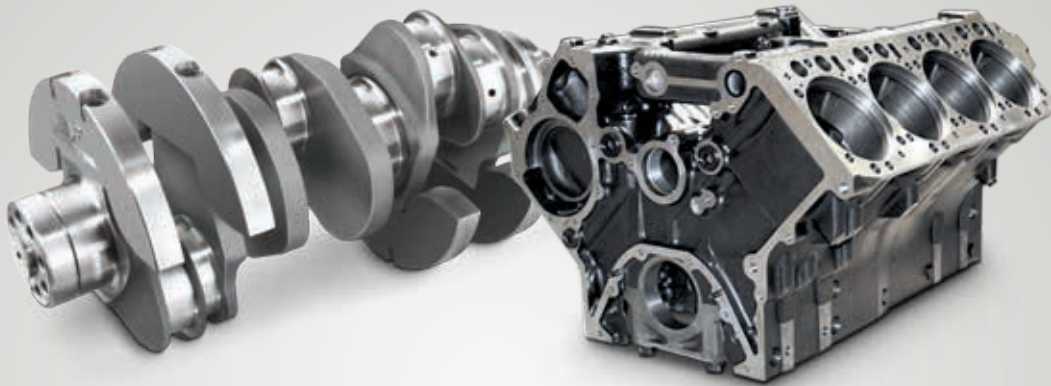

## **Crankshafts**

### **Forged masterpieces for every torque**

To ensure high quality standards, the forged BF crankshafts are produced with tools manufactured in-house. They are also subject to stringent checks. The dimensional accuracy ensures smooth running and therefore a long engine life.

## **Crankcase**

### **Geometric precision and dimensional stability for optimal performance**

As the housing for the drive mechanism and cooling jacket, the crankcase forms the central component of the engine. BF offers a comprehensive and high-quality portfolio of crankcases to provide quick, cost-effective solutions for repairing engines on utility vehicles.



## **Connecting rods**

### **Robust force transmission**

The high strain on the connecting rod due to tension, pressure and torsional forces requires connecting rod designs with high strength yet low weight. Connecting rods with a lower strength are an unnecessary risk for the engine. With the high-quality product range from Motorservice, you are always on the safe side.



## **Oil and water pumps**

### **Perfect lubricant and coolant supply**

Rheinmetall Automotive develops and supplies oil and water pumps to all leading engine manufacturers and has numerous patents. Building on this know-how, Motorservice offers pumps for a multitude of passenger car and utility vehicle applications. Make the most of this experience at a fair price/performance ratio.



## **Cylinder heads**

### **Completed to your requirements**

Motorservice boasts an extensive product portfolio of cylinder heads for passenger cars and utility vehicles. The cylinder heads are also available with pre-assembled valves and valve-springs according to requirements and for ease of repair.



### Camshafts

#### Wear-resistant cams for long, powerful engine life

To withstand the high bending and torsion forces over the long term, the camshafts in the Motorservice product range have been designed to incorporate high strength properties. Camshafts may be cast or forged, depending on their intended purpose.



### Control parts for camshafts

#### Temperature-resistant precision

The high-quality control parts from BF support the camshaft with its task of opening and closing the individual valves at a precise defined time with the exact stroke and in the defined sequence.



### Oil coolers

#### Risk minimization during reconditioning

Together with the coolant system, the oil cooler ensures thermal equilibrium within the engine. Deposits of dirt particles in the fine lamellae can cause engine damage when oil coolers are reused – a high risk. Motorservice therefore offers oil coolers for a wide range of utility vehicle types.



### Flywheels

#### Precision and weight for smooth engine running

BF flywheels are precision parts made from high-value grey cast iron or steel which efficiently reduce uneven running and vibration in the engine. This ensures that wear on the gear train is kept to a minimum.



# Know-how transfer



## Professional knowledge from the experts

### Worldwide training

#### *Direct from the manufacturer*

Each year, around 4,500 mechanics and engineers benefit from our training courses and seminars, which we hold on-site in locations across the world or in our training centres in Neuenstadt, Dormagen and Tamm (Germany).

### Technical information

#### *From practical experience for practical use*

Our Product Information and Service Information publications, technical brochures and posters keep you at the forefront of the latest technological developments.

### Technical videos

#### *Professional installation clearly illustrated*

Knowledge transfer via video: In our videos, you will find practice-orientated fitting instructions and system explanations relating to our products.

### News

#### *Regular information via e-mail*

Subscribe online to our free newsletter now and receive regular information about additions to the product range, technical publications and much more.

### Social media

#### *Always up to date*



### Individual information

#### *Especially for our customers*

We provide extensive information and services relating to our wide range of services: e.g. personalised sales-promoting materials, sales support, technical support and much more.



[www.ms-motorservice.com](http://www.ms-motorservice.com)

**Products in Focus online**  
*Get information on the products online*

Interactive elements, animations and video clips provide interesting information about our products in and around the engine.

**OnlineShop**  
*Your direct access to our products*  
 Order at any time. Quick availability check.  
 Extensive product search by engine, vehicle, dimensions etc.

**Technipedia**  
*Are you looking for technical information relating to engines?*  
 We share our know-how with you in our Technipedia. You can get professional knowledge direct from experts here.

**Motorservice app**  
*Access technical know-how on the move*  
 Here, you will find the latest information and services relating to our products quickly and easily.





**MOTORSERVICE**  
RHEINMETALL AUTOMOTIVE

**BF spare parts**

**40 years of reliable quality for a reconditioning  
based on the current market value**



Motorservice Partner:

Headquarters:

**MS Motorservice International GmbH**

Wilhelm-Maybach-Straße 14-18

74196 Neuenstadt, Germany

[www.ms-motorservice.com](http://www.ms-motorservice.com)



4 028977 827280

50020034-02 - EN - 07/17 (072017)  
© MS Motorservice International GmbH

 **TecAlliance**  
Data Supplier