



# KNOWLEDGEPOOL

## DAMAGE TO ENGINE BEARINGS



## **MOTORSERVICE GROUP**

### QUALITY AND SERVICE FROM A SINGLE SOURCE

The Motorservice Group is the sales organisation for the global aftermarket activities of Rheinmetall. It is a leading supplier of engine components for the independent aftermarket. With the premium brands Kolbenschmidt, Pierburg, TRW Engine Components and the BF brand, Motorservice offers its trade and repair shop customers a wide and comprehensive range of top-quality products.

## **RHEINMETALL**

### TECHNOLOGY FOR FUTURE MOBILITY

As a global supplier to the automotive industry, Rheinmetall's expertise in air supply systems, emission control and pumps and in the development, manufacture and spare parts supply of pistons, engine blocks and engine bearings puts it right at the top of the markets. Product development is carried out in close cooperation with well-known automotive manufacturers.



**KOLBENSCHMIDT**



**PIERBURG**



**TRW**  
EngineComponents

---

**Edited by:**  
Motorservice, Technical Market Support

**Layout and production:**  
Motorservice, Marketing

This document must not be reprinted, duplicated or translated in full or in part without our prior written consent or without reference to the source of the material.

All content including pictures and diagrams is subject to alteration. No liability accepted.

**Published by:**  
© MS Motorservice International GmbH

#### **Liability**

All information in this brochure has been carefully researched and compiled. Nevertheless, it is possible that errors have occurred, information has been translated incorrectly, information is missing or the details provided have changed in the intervening time. As a result, we are unable to provide any guarantee nor to accept any legal liability for the accuracy, completeness, currency or quality of the information provided. We hereby waive all liability for any damages, whether direct or indirect in nature and whether tangible or intangible, resulting from the use or misuse of information or from incomplete or incorrect information in this brochure, unless proven to be the result of deliberate intent or negligence on our part. Likewise, we shall not be liable for damage arising because the engine reconstructor or mechanic does not have the necessary technical expertise, the required knowledge of, or experience in repairs. The extent to which the technical methods and repair information described here will apply to future engine generations cannot be predicted and must be verified in individual cases by the engineer servicing an engine or the workshop operator.

---

<b>CONTENTS</b>		<b>PAGE</b>
<b>1.</b>	<b>BASIC INFORMATION</b>	<b>5</b>
1.1	Bearing positions in the engine	5
1.2	Main bearings and connecting rod bearings in the crank mechanism	6
1.3	Functions of engine bearings	7
1.4	Structure of engine bearings	8
1.5	Removal of engine bearings in the event of damage	10
<b>2.</b>	<b>WEAR DUE TO MIXED FRICTION</b>	<b>12</b>
2.1	Introduction	12
2.2	Adaptive run-in wear	13
2.3	Initial rubbing marks	14
2.4	Seizure	16
2.5	Special cases	18
2.5.1	One-sided edge wear	20
2.5.2	One-sided alternate edge wear	22
2.5.3	Two-sided edge wear	24
2.5.4	Wide wear marks in the centre of the bearing in the circumferential direction	26
2.5.5	Stripe-like wear in the centre of the bearing	28
2.5.6	Wear on opposing areas of the separation planes	30
2.5.7	Two-sided wear on areas of the separation planes	32
2.5.8	Narrow zone of wear in the crown of the bearing shell	34
2.5.9	Narrow, wear-free strips at the edges of the bearings	36
<b>3.</b>	<b>DAMAGE DUE TO THE INFLUENCE OF PARTICLES</b>	<b>38</b>
3.1	Introduction	38
3.2	Scoring	40
3.3	Embedding	42
3.4	Dirt progression marks	44
3.5	Foreign particles on bearing back	46
<b>4.</b>	<b>EROSION AND CAVITATION</b>	<b>48</b>
4.1	Erosion	48
4.2	Cavitation	49
<b>5.</b>	<b>FATIGUE DAMAGE</b>	<b>52</b>
5.1	Introduction	52
5.2	Cracks and nicks to the sliding layer	54
5.3	Cracks and nicks to the bearing metal	55
<b>6.</b>	<b>OVERHEATING DAMAGE</b>	<b>56</b>
6.1	Introduction	56
6.2	Heat cracks	57
6.3	Fusing of the sliding layer	58
6.4	Discolouration of the sliding layer and / or the back of the bearing	59
<b>7.</b>	<b>CORROSION</b>	<b>60</b>
7.1	Frictional corrosion / Contact corrosion	61
7.2	Chemical corrosion	62
<b>8.</b>	<b>DAMAGE TO THRUST WASHERS</b>	<b>64</b>
<b>9.</b>	<b>GLOSSARY</b>	<b>66</b>

# ABOUT THIS BROCHURE

This brochure provides an overview of the different types of damage in engine half shell bearings and thrust washers. It also supports experts with diagnostics and determining the cause of damage.

The process of assessing engine damage always requires an all-encompassing approach to identify the causes, which may not always be clear. Following engine repair, failures may often occur again. This is because damaged components may have been replaced, but the cause of damage has not been rectified.

Due to the high level of complexity of the interaction between the individual components of a bearing inside the engine, the cause of damage is generally not easy to recognise. This is frequently not to be found in the bearing itself, but in the surroundings of the bearing.

Even though the bearing generally suffers the greatest damage, the replacement alone of the damaged bearing often does not rectify the cause of damage.

During professional engine reconditioning, the actual cause of the damage must therefore first of all be determined to then be able to take the suitable repair measures.

For each case of damage shown, the characteristic damage symptoms are demonstrated using suitable bearing shells. It should be noted that different damage symptoms may arise for different materials. Due to the different characteristics of damage symptoms, there may be deviations from the images shown in the brochure.

## 01 Housing bore (example: connecting rod):

- Rigidity (elasticity and strength)
- Thermal distortion
- Manufacturing tolerances
- Surface quality
- Screw tightening torques

## 02 Shaft journals:

- Material (e.g. cast or steel shaft)
- Rigidity (elasticity and strength)
- Thermal distortion
- Manufacturing tolerances
- Surface quality

## 03 Lubrication:

- Lubricant (viscosity, additives)
- Oil supply (oil level, oil pressure, oil pump, oil lines, oil filter)
- Level of contamination

## 04 Bearing shell:

- Material (resistance, wear resistance, dry-running behaviour, embedding properties)
- Manufacturing tolerances
- Surface quality

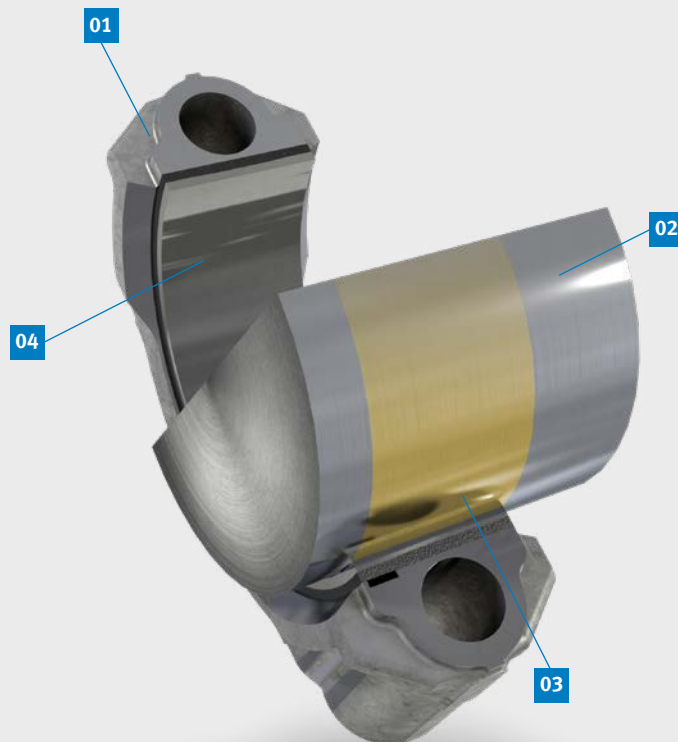

# 1. BASIC INFORMATION

## 1.1 BEARING POSITIONS IN THE ENGINE

The image of the six-cylinder engine shows the bearing positions in the engine. Seven main bearings are installed, one of which is designed as a thrust bearing. Between each of the main bearings you can find the connecting rod bearings – one connecting rod bearing per cylinder.

The other bearing positions, such as camshaft bearings, conrod bushes and bearings for balancer shafts, are generally not half shell bearings but plain bearing bushes.

This brochure focuses on the half shell bearings which are used as bearings for the connecting rod and crankshaft in the crank mechanism.

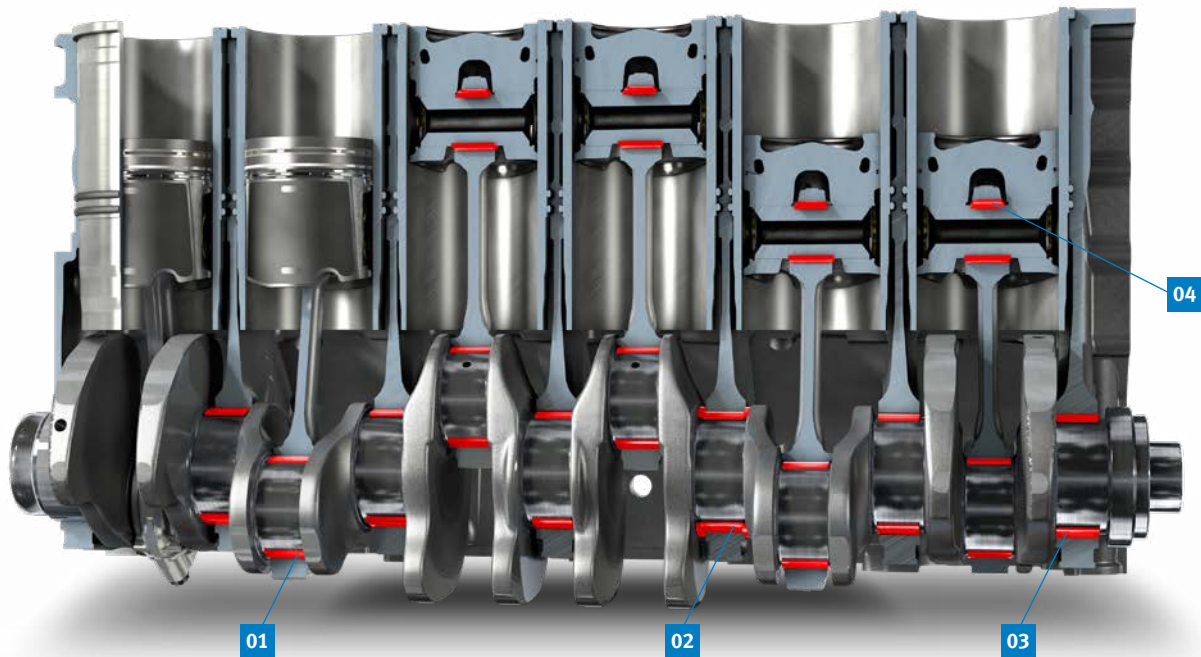

**01** Connecting rod bearings



**02** Thrust washers / main bearings or flanged bearings



**03** Main bearings



**04** Conrod bushes

# 1.2 MAIN BEARINGS AND CONNECTING ROD BEARINGS IN THE CRANK MECHANISM

Connecting rod bearings connect the connecting rod with the crankshaft. The bearing shells can be divided into those on the rod side and those on the cap side; the bearing shells on the rod side are subject to much more strain than those on the cap side. The ignition force generated during combustion is transferred to the crankshaft through them. In petrol engines, the bearing shells on the cap side are also subject to a high stress as there are high inertial forces due to the higher speeds compared to a diesel engine. Connecting rod bearings are supplied with oil via bores from the main bearing via the crankshaft.

The bearings of the crankshaft are main bearings. Here, the bearing is also divided into an upper and lower bearing shell. For the main bearings, the lower bearing shell is subject to a higher strain by absorbing the ignition forces. The forces transferred from a connecting rod to the crankshaft are absorbed by several main bearings, meaning that these are subject to a lower strain than the conrod bearing shells on the rod side. The upper main bearing shell contains an oil groove which conveys the oil to the connecting rod bearings via bores in the crankshaft.

In order to also be able to absorb axial forces, which arise when the clutch is actuated, for example, thrust washers or composite bearings are installed as thrust bearings.

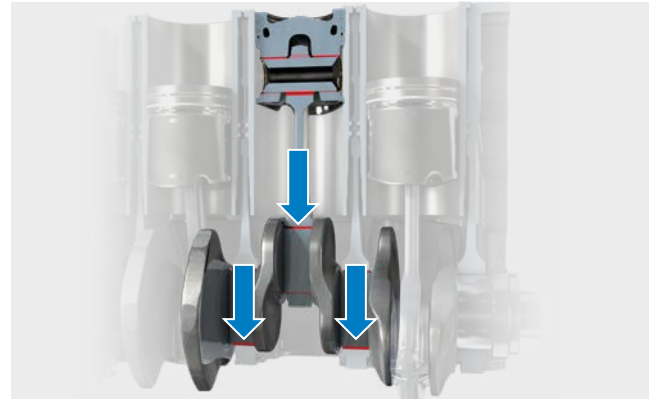

# 1.3 FUNCTIONS OF ENGINE BEARINGS

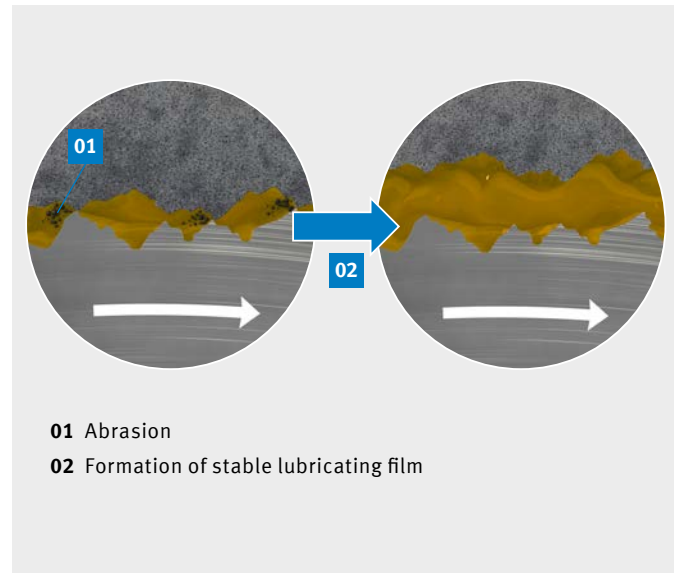
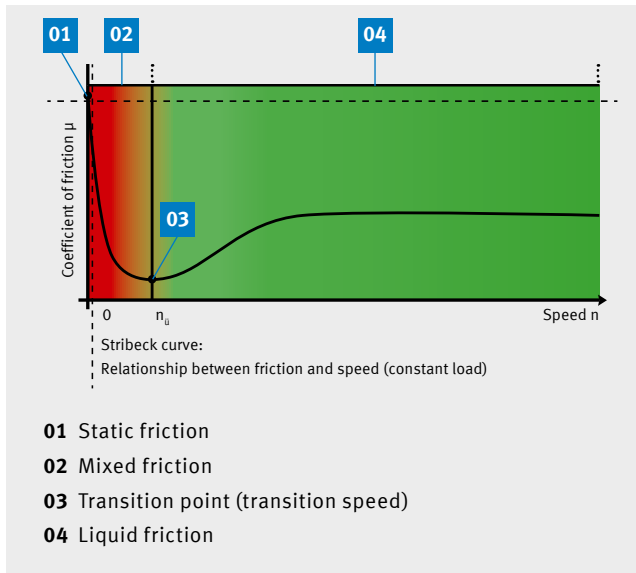

The main function of engine bearings is to absorb and transmit forces between components which are moving in relation to one another. Friction should also be minimised, thereby enabling a practically wear-free rotary motion. During operation, frictional forces are generated in every bearing which counteract the rotary motion and thereby generate heat. In order to reduce these forces and to dissipate the frictional heat, it is necessary to have a lubricating film between the bearing and the shaft journals. Without this lubricating film, direct contact causes dry friction, which in turn causes wear and abrasion on the bearing.

Hydrodynamic engine bearings, in which a stable lubricating film forms through the relative movement between the bearing shell and journal alone, pass through a mixed friction range up to a particular transition speed.

At low speeds, the hydrodynamic lift is not enough to keep the surfaces completely separate from one another. This results in partial contact between the sliding surfaces, creating the risk of bearing damage. It is only when the speed increases that the frictional forces are reduced and a permanent lubrication film is formed. Liquid friction/fluid friction is generated, whereby both the sliding surfaces are completely separate from one another. So that the reliable functioning of the bearing can be ensured, the resulting lubricant pressure in the bearing gap must be large enough to absorb the forces acting on the bearing without contact of the sliding surfaces. This is the ideal operating point for engine bearings. But this form of friction also generates heat, meaning that sufficient lubrication is also required for heat dissipation.

# 1.4 STRUCTURE OF ENGINE BEARINGS

In accordance with the standard DIN 50282 („The Tribological Behaviour of Metallic Antifriction Materials – Significant Definitions“), the tribological behaviour of an anti-friction material can be characterised by terms such as running-in behaviour, embedding properties, dry-running behaviour, wear resistance and adaptability. The requirements made of the engine bearing are therefore crucial when it comes to the choice of material.

There are two different anti-friction material families.

## TWO-COMPONENT BEARINGS

- Steel-aluminium composites

Two-component bearings consist of a steel back, an intermediate layer made of pure aluminium and the plated bearing material. In the majority of cases, an aluminium alloy with tin, copper and silicon additives is selected for the material.

Image of bearing structure

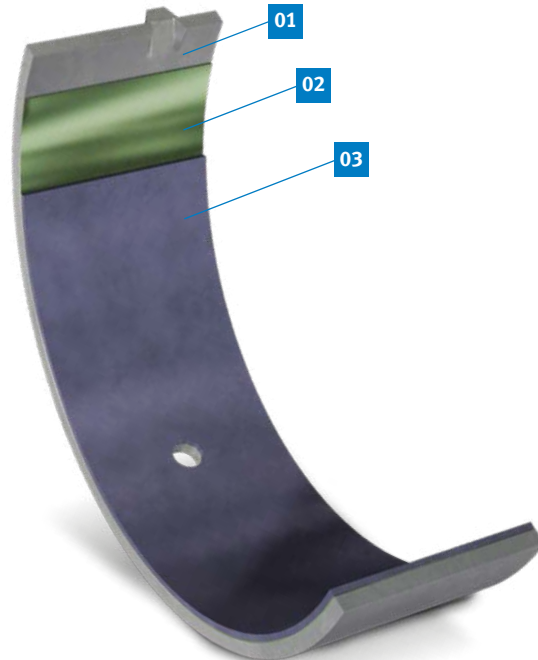

- 01 Steel back
- 02 Intermediate layer (if required)
- 03 Bearing material



---

### Steel-aluminium

---

Bearing material: Aluminium



**THREE-COMPONENT BEARINGS**

- Sintered / cast steel-bronze or steel-brass composites with an overlay
- Steel-aluminium composites with an overlay

Depending on the area of application and its specific requirements, the overlay of the three-component bearings is applied as an additional sliding layer in the form of a sputter, galvanic or bonded coating layer. The bearing metal (aluminium, bronze or brass alloy) is plated, cast or sintered onto the steel back. If required, an intermediate layer made of nickel or a nickel alloy is applied between the bearing material and the sliding layer (overlay) as a diffusion barrier.

Different materials can therefore be used for engine bearings depending on the requirements. Often a different material is chosen for the bearing shell subject to the higher stress than for the opposing bearing shell. In a V engine, the conrod bearing shells are produced, for example, with a half shell bearing with a sputter coating on the rod side, and with a half shell bearing made from a steel-aluminium composite without coating on the cap side.

**Image of bearing structure**

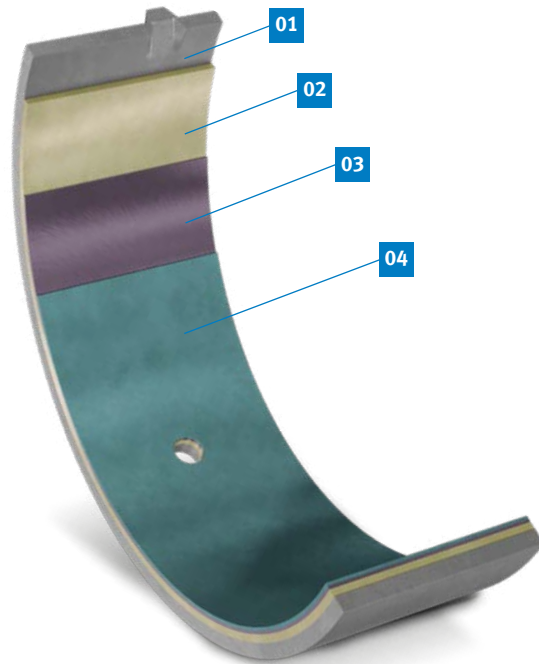

- 01** Steel back
- 02** Bearing material
- 03** Intermediate layer (if required)
- 04** Sliding layer (overlay)



**Galvanic**

Bearing material: Bronze  
Intermediate layer  
Sliding layer: Galvanic



**Bonded**

Bearing material: Aluminium or bronze  
Sliding layer: Bonded



**Sputter**

Bearing material: Brass or bronze  
Intermediate layer (for bronze)  
Sliding layer: Sputter

# 1.5 REMOVAL OF ENGINE BEARINGS IN THE EVENT OF DAMAGE

The following should be noted during the removal of bearing shells in the event of damage:

- The bearing shells should be labelled according to seat and position in the main bearing centre line so that the events leading to the damage can be better understood. In addition to the appearance of the bearing, the seat can often provide information on the events leading to the damage. In the event of bending of the crankshaft, above all the first and last main bearing along the centre line demonstrate one-sided wear marks, for example.
- Operating conditions (duration, type of stress) and other influences, such as the oil used, must be documented so that it is possible to have a better assessment of the damage.
- Issues with other engine components, for example the crankshaft, must also be documented. In the majority of cases, damage to the interacting sliding partner of the engine bearing can be recognised. Often, damage to the bearing is also the result of damage to other engine components.
- In order to allow subsequent analyses, a sample should be taken of the oil used and the oil filter retained. Particle residues can be documented and analysed, providing information about possible causes of damage.
- The torques required to loosen the engine bolts must be documented. If the bolts are not fastened with the right torque, relative movement between the bearing shell and the housing bore may be the result.



Tightening the bolts in accordance with the manufacturer's instructions



Documenting the seat and position of the bearing



Comparison of the old and new bearings

## 2. WEAR DUE TO MIXED FRICTION

### 2.1 INTRODUCTION

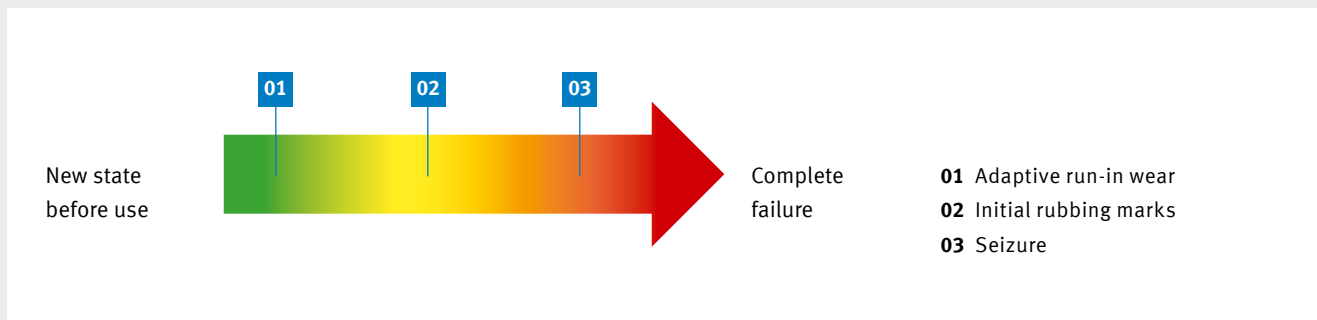

Wear is the progressive loss of material from the surface of a solid body, due to mechanical action, i.e. the contact and relative motion against a solid, liquid or gaseous counterbody (DIN 50320).

In bearing shells, wear is caused by metallic contact due to mixed friction between the bearing and the shaft journal.

This is the case, for example, each time the engine is started and stopped. Between standstill and the transition speed of the shaft, the bearings used pass through the mixed friction range. In this range, the load bearing capacity of the lubricating film is not always sufficient to completely separate the interacting sliding parts from each other (see chapter: „1.3 Functions of engine bearings“). Especially for vehicles with start / stop function, wear-resistant materials therefore play an important role. At low speeds and high stress, it may also occur that liquid friction is not achieved and the bearing is worn. Deviations in terms of geometry due to installation errors or the deformation of journals and the bearing line may also cause wear.

During the first hours of operation of a bearing, the interacting sliding parts adapt. Here, roughness peaks are smoothed and the roughness profile levelled. This adaptive run-in wear can by all means be considered desirable and does not represent an impairment of the function of the bearing. When the influence of the mixed friction intensifies, the common adaptive run-in wear develops through an initial rubbing mark to seizure – and therefore complete failure.

## 2.2 ADAPTIVE RUN-IN WEAR

### DESCRIPTION

- Bright, smooth wear marks in the main load area
- Marks which gradually start and taper off
- Machining structure of the bearing is still recognisable



**Lower main bearing shell  
steel-aluminium composite  
(without coating)**

In the centre of the bearing, a bright stripe of wear can be seen. In the area of the relief and the edges of the bearing, no traces of operation are visible, however. Here, the machining structure of the bearing can still be recognised.

### ASSESSMENT

During the initial hours of operation of a bearing, the roughness peaks are smoothed and the roughness profile levelled through the contact between the bearing and shaft journal during mixed friction operation. The wear mainly appears in the main load area of the bearing or in areas of macroscopic form deviations (see chapter: „2.5 Special cases“).

The adaptive run-in wear is desired and therefore does not represent damage to the bearing.

---

#### NOTE

The function of the bearing is not impaired.

---

If, however, the adaptive run-in wear intensifies (for example due to a sustained error in alignment and form), initial rubbing marks, seizure or fatigue damage may be the result.

## 2.3 INITIAL RUBBING MARKS

### DESCRIPTION

- Bright, smooth marks of mixed friction, above all in the main load area
- Sliding layer displaced into the relief area, mostly in the direction of rotation and tongue-shaped
- Scoring

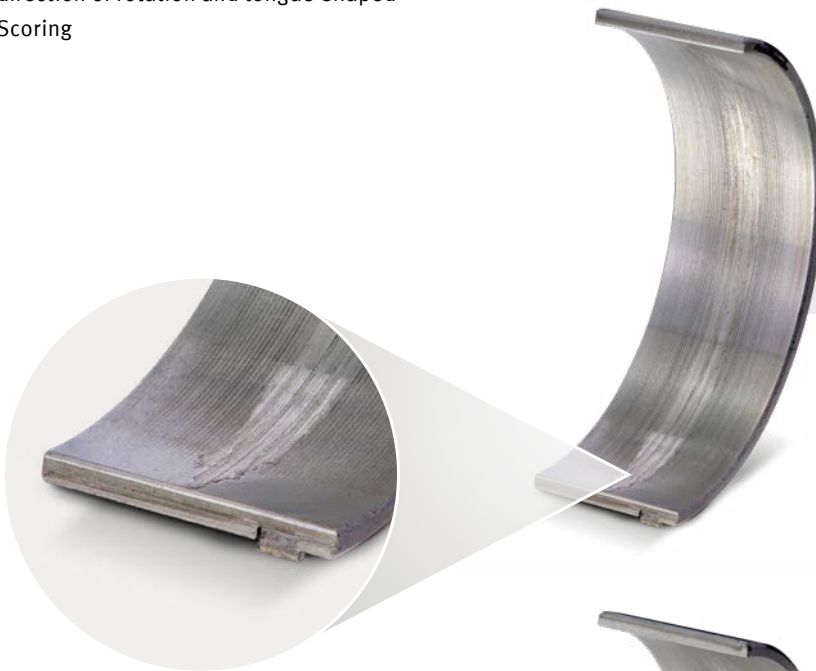

**Cap-side conrod bearing shell  
steel-aluminium composite**

In the centre of the bearing a clear bright mark of mixed friction, with associated scoring, is recognisable. The wear pattern is displaced out into the relief area.

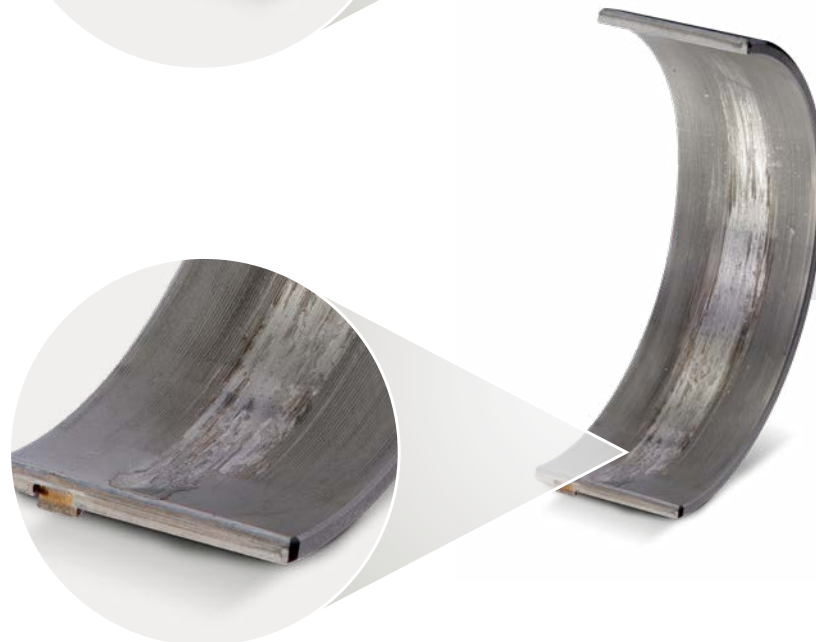

**Rod-side conrod bearing shell  
steel-brass composite with  
sputter coating**

A bright mark of mixed friction, with partial associated scoring, is recognisable. The sputter coating has been displaced out into the relief area. The area where the sputter coating has already seized has fused.

## ASSESSMENT

Initial rubbing marks may result from run-in marks if the effect of mixed friction intensifies. If this is a temporary state, these may be levelled out again; the functionality of the bearing is not further impaired. Assessing this is very difficult, however.

If the mixed friction state is continued, the initial rubbing marks are strengthened and scoring at the journal may occur. The result is seizure at the affected bearing shells, whereby the bearing shell welds with the journal due to thermal stress.

---

## POSSIBLE CAUSES

- Oil bores not free: the reason may be the incorrect installation of the bearing shells or blockage of the oil bores – the latter is often the case when biological fuels are used
- The lubrication gap is too small, meaning that a stable lubrication film cannot be formed – cause: form and geometry deviations of the shaft or journal, or bending of the crankshaft
- The lubrication gap is too large, meaning that the hydrodynamic pressure required for the formation of the stable lubricating film is not achieved
- Oil level or oil pressure too low
- Blocked oil filter
- Defective oil pump
- Leak in the oil lines
- Overstressing of the bearings: the strain is higher than the bearing is designed for – causes are chip tuning or piston seizure, for example
- Effect of particles: particles find their way into the bearing gap, causing initial rubbing marks on the journal and bearing. In the event of embedding or scoring, edges are created, resulting in greatly increased mixed friction

---

## REMEDY

Initial rubbing marks may continue to develop into seizure of the bearings. It is therefore important to replace the bearings and to rectify the cause:

- Check that all of the oil bores are free and that there is no blockage
- Check the actual bearing clearance: if it is not within the tolerance range, form and geometry errors are often the cause (see chapter: „2.5 Special cases“)
- Check the functioning of the oil filter and always change the oil filter and oil according to the manufacturer's instructions
- Check the oil level and oil pressure and readjust if necessary
- Check the oil pump is functioning
- Check the oil lines for any leaks
- Check the stress of individual bearings
- Check the entire bearing set for the embedding of particles or grooves. If present, the influence of particles may have caused the formation of the initial rubbing marks (see chapter: „3. Damage due to the influence of particles“)

## 2.4 SEIZURE

### DESCRIPTION

- Areas of torn-out material
- Pronounced scoring and deformation
- Exposure as well as roughening and fissures
- Occurrence of free spread measure is visible with the naked eye in comparison to adjacent bearing shells without seizure
- Overheating phenomena, such as fusing of the bearing material and discolouration, often occur together with seizure



**Lower main bearing shell  
steel-aluminium composite**

Fusion and displacement of the bearing material beyond the edge of the bearing, as well as a jagged surface with areas of torn-out material, are present.



## ASSESSMENT

High temperatures in the area of high mixed friction cause localised welding between the journal and bearing. These welded areas break up again, whereby the bearing material – which is softer compared to the crankshaft – is torn off. An acute lack of lubricant is the cause here. The temperature development caused by this causes overheating damage – a common side effect of bearing seizure.

Damage due to the influence of particles or initial rubbing marks may occur at adjacent bearings due to the deposits from abrasion brought in through the lubricant circuit.

Initial rubbing marks are the preliminary stages of bearing seizure.

---

## POSSIBLE CAUSES

- Oil bores not free: the reason may be the incorrect installation of the bearing shells or blockage of the oil bores – the latter is often the case when biological fuels are used
- The lubrication gap is too small, meaning that a stable lubrication film cannot be formed – cause: form and geometry deviations of the shaft or journal, or bending of the crankshaft
- The lubrication gap is too large, meaning that the hydrodynamic pressure required for the formation of the stable lubricating film is not achieved
- Oil level or oil pressure too low
- Blocked oil filter
- Defective oil pump
- Leak in the oil lines
- Overstressing of the bearings: the strain is higher than the bearing is designed for – causes are chip tuning or piston seizure, for example
- Effect of particles: particles find their way into the bearing gap, causing initial rubbing marks on the journal and bearing. In the event of embedding or scoring, edges are created, resulting in greatly increased mixed friction

---











## REMEDY



Seizure is amongst the most serious types of bearing damage. The bearing is destroyed and has to be replaced. If use of the bearing is continued, other engine components may be damaged.

- Check that all of the oil bores are free and that there is no blockage
- Check the actual bearing clearance: if it is not within the tolerance range, form and geometry errors are often the cause (see chapter: „2.5 Special cases“)
- Check the functioning of the oil filter and always change the oil filter and oil according to the manufacturer’s instructions
- Check the oil level and oil pressure and readjust if necessary
- Check the oil pump is functioning
- Check the oil lines for any leaks
- Check the stress of individual bearings
- Check the entire bearing set for the embedding of particles or grooves. If present, the influence of particles may have caused the formation of the initial rubbing marks (see chapter: „3. Damage due to the influence of particles“)

## 2.5 SPECIAL CASES

There are some cases where the bearing shells display a special wear pattern. The following damage pictogram can be used to assign possible damage symptoms to a type of damage.

Lower bearing shell	Upper bearing shell	Chapter
		<b>2.5.1</b> <b>One-sided edge wear</b> <ul style="list-style-type: none"><li>• On the upper and lower shell, on the same side in each case</li></ul>
		<b>2.5.2</b> <b>One-sided alternate edge wear</b> <ul style="list-style-type: none"><li>• On the upper and lower shell, diagonally opposed</li><li>• Different areas may be pronounced to differing degrees</li></ul>
		<b>2.5.3</b> <b>Two-sided edge wear</b> <ul style="list-style-type: none"><li>• On the upper and lower shell on both sides</li></ul>
		<b>2.5.4</b> <b>Wide wear marks in the centre of the bearing</b> <ul style="list-style-type: none"><li>• Generally pronounced to the same extent on the upper and lower shell</li><li>• No pronounced wear pattern for main bearing shells in the upper bearing shell due to oil groove</li></ul>
		<b>2.5.5</b> <b>Stripe-like wear in the centre of the bearing</b> <ul style="list-style-type: none"><li>• Generally pronounced to the same extent on the upper and lower shell</li><li>• No pronounced wear pattern for upper main bearing shells with oil groove</li></ul>

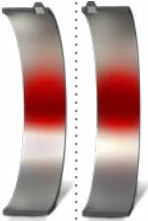
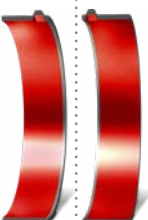
Lower bearing shell	Upper bearing shell	Chapter
		<b>2.5.6</b> <b>Wear on opposing areas of the separation planes</b>
		<b>2.5.7</b> <b>Two-sided wear on areas of the separation planes</b>
		<b>2.5.8</b> <b>Narrow zone of wear in the crown of the bearing shell</b>
		<b>2.5.9</b> <b>Narrow wear-free strips at the edges of the bearings</b> <ul style="list-style-type: none"><li>• May occur on one edge or both edges</li></ul>

## 2.5.1 ONE-SIDED EDGE WEAR

### DESCRIPTION

- Bright, light stripes of wear on one side at the edge of the bearing
- Identifiable signs of material fatigue or initial rubbing marks possible in the area of the edge wear in severe cases
- Overheating phenomena such as discolouration due to thermal stress or carbon deposits in the area of the edge wear on the bearing back

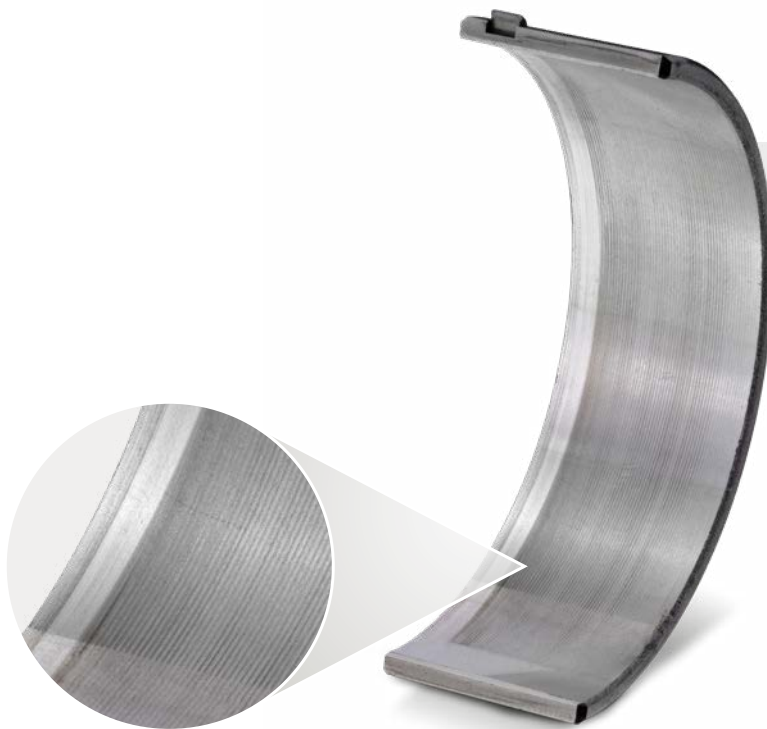

**Lower main bearing shell  
steel-aluminium composite**

One-sided worn bearing edge is visible. The wear occurs in the form of adaptive run-in wear. The function of the bearing is not impaired.

## ASSESSMENT

The lubrication gap at the bearing edge is too low, meaning that the lubricating film is not fully stable and mixed friction occurs locally. If the shortage of lubrication continues, the temperature increases due to the frictional heat that results. This could result in overheating damage such as dark discolouration of the bearing back. The shortage of lubrication continues to intensify due to the increasing temperature level and the process reinforces itself until the first initial rubbing marks occur and fatigue damage occurs due to increased surface pressure.

Depending on the intensity of the wear at the bearing edges, this can be considered as completely normal. During operation, the crankshaft is subject to bending, which above all has an effect on the outer main bearings. The outer bearings therefore demonstrate more pronounced edge wear.

## POSSIBLE CAUSES

- Tapered ground journal (Fig. 1)
- Tapered bearing bore (Fig. 2)
- Rounding radius too large on one side (Fig. 3)
- Bending of the crankshaft: during installation, the crankshaft was not balanced or is deformed due to mechanical strain during operation
- Bearing bore which is not aligned due to bolts with the incorrect tightening torque during the assembly of the engine or excessive distortion of the main bearing centre line due to temperature development during operation
- Axial shell misalignment

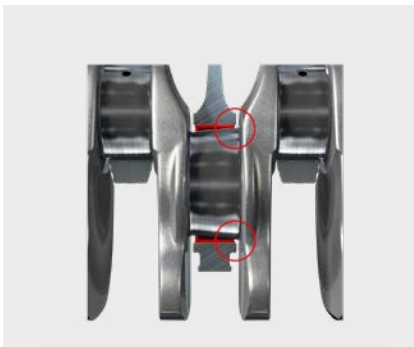

Fig. 1: Tapered ground journal



Fig. 2: Tapered bearing bore

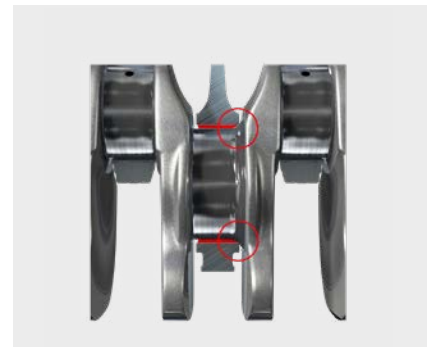

Fig. 3: Rounding radius too large on one side

## REMEDY

Bearings that exhibit edge wear can continue to be used depending on their wear condition.

If these damage symptoms intensify after a few hours of operation, measures to determine the cause should be taken:

- Check for correct geometry of the crankshaft: dimensions, roundness, cylindricity, ripple, surface roughness
- Check the bearing line bore is correct: dimensions, roundness, cylindricity, surface
- Balance crankshaft during installation and check strain on the shaft
- Check alignment of the main bearing bore: during assembly of an engine, always make sure to use the specified tightening torques and bolt tightening sequence – the engine must be sufficiently cooled during operation as deformations may also occur due to temperatures that are too high
- Check connecting rods for angularity before installation

## 2.5.2 ONE-SIDED ALTERNATE EDGE WEAR

### DESCRIPTION

- Bright, light stripes of wear – opposite each other on one side of the upper and lower shells
- Identifiable signs of material fatigue or initial rubbing marks possible in the area of the edge wear
- Overheating phenomena such as discolouration possible due to thermal stress or carbon deposits in the area of the edge wear on the bearing back



**Rod-side conrod bearing shell  
steel-brass composite with  
sputter coating**



**Cap-side conrod bearing shell  
steel-aluminium composite**

The diagonally offset wear pattern can be recognised. At the edge of the bearing, the intensity of the wear is pronounced to differing degrees in different areas. The function of the bearing is not impaired.

## ASSESSMENT

The lubrication gap at the bearing edge is too low, meaning that the lubricating film is not fully stable and mixed friction occurs locally. If the shortage of lubrication continues, the temperature increases due to the frictional heat that results. This could result in overheating damage such as dark discolouration of the bearing back.

The shortage of lubrication continues to intensify due to the increasing temperature level and the process reinforces itself until the first initial rubbing marks occur and fatigue damage occurs due to increased surface pressure.

## POSSIBLE CAUSES

- Misalignment of the journals or housing (Fig. 1)
- Incorrect rounding radii of the shaft
- „Maladjustment“ of the connecting rod (warped or twisted) (Fig. 2)
- Deformation of the crankcase



Fig. 1: Misalignment



Fig. 2: „Maladjustment“ of the connecting rod

## REMEDY

Bearings that exhibit edge wear can continue to be used depending on their wear condition.

If these damage symptoms intensify after a few hours of operation, measures to determine the cause should be taken:

- Check for correct geometry of the crankshaft: dimensions, roundness, cylindricity, ripple, surface roughness
- Check the bearing line bore is correct: dimensions, roundness, cylindricity, surface
- Balance crankshaft during installation and check strain on the shaft
- Check alignment of the main bearing bore: during assembly of an engine, always make sure to use the specified tightening torques and bolt tightening sequence – the engine must be sufficiently cooled during operation as deformations may also occur due to temperatures that are too high
- Check connecting rods for angularity before installation

## 2.5.3 TWO-SIDED EDGE WEAR

### DESCRIPTION

- Bright, light stripes of wear on both sides at the edge of the bearing
- Identifiable signs of material fatigue or initial rubbing marks possible in the area of the edge wear
- Overheating phenomena such as discolouration possible due to thermal stress or carbon deposits in the area of the edge wear on the bearing back

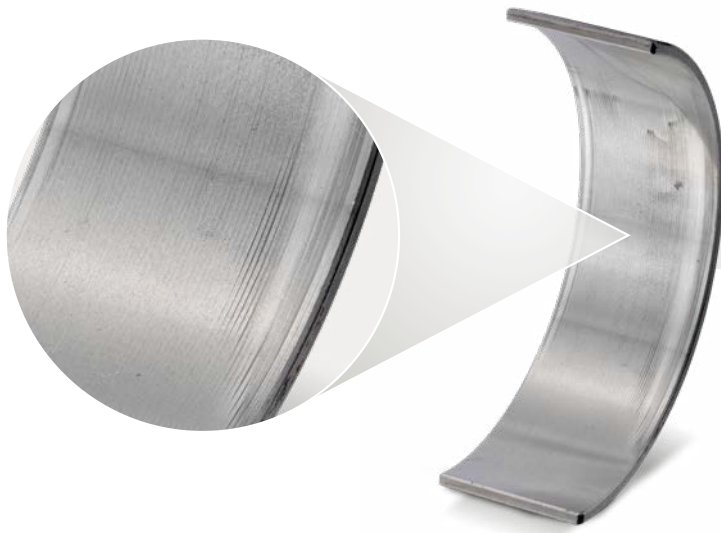

**Cap-side conrod bearing shell  
steel-aluminium composite**

Two-sided edge wear in the early stages – wear in the form of adaptive run-in wear.

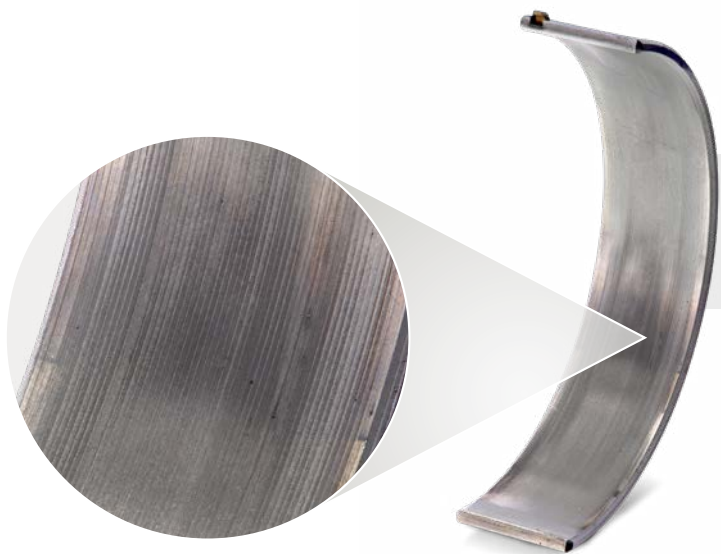

**Rod-side conrod bearing shell  
steel-brass composite with  
sputter coating**

Two-sided edge wear in the early stages – wear in the form of adaptive run-in wear.



## ASSESSMENT

The lubrication gap at the bearing edge is too low, meaning that the lubricating film is not fully stable and mixed friction occurs locally. If the shortage of lubrication continues, the temperature increases due to the frictional heat that results. This could result in overheating damage such as dark discolouration of the bearing back. The shortage of lubrication continues to intensify due to the increasing temperature level and the process reinforces itself

until the first initial rubbing marks occur and fatigue damage occurs in this area due to increased surface pressure. Two-sided edge wear occurs very often in the main load area of a bearing. Depending on the intensity of the wear, this can be considered normal, and does not impair the functioning.

## POSSIBLE CAUSES

- Concave journal form (Fig. 1)
- Concave bearing bore (Fig. 2)
- Too large a rounding radius between the journal and crank web (Fig. 3)
- Too large an axial clearance, maladjustment of the connecting rod
- Journal ground at an angle (Fig. 4)



Fig. 1: Concave journal form



Fig. 2: Concave bearing bore



Fig. 3: Too large a rounding radius

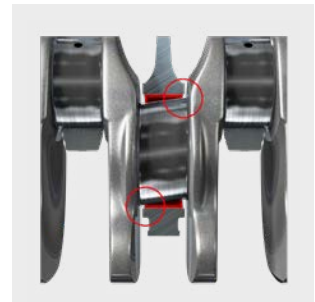

Fig. 4: Journal ground at an angle

## REMEDY

Bearings that exhibit edge wear can continue to be used depending on their wear condition.

If these damage symptoms intensify after a few hours of operation, measures to determine the cause should be taken:

- Check for correct geometry of the crankshaft: dimensions, roundness, cylindricity, ripple, surface roughness
- Check the bearing line bore is correct: dimensions, roundness, cylindricity, surface
- Balance crankshaft during installation and check strain on the shaft
- Check alignment of the main bearing bore: during assembly of an engine, always make sure to use the specified tightening torques and bolt tightening sequence – the engine must be sufficiently cooled during operation as deformations may also occur due to temperatures that are too high
- Check connecting rods for angularity before installation

## 2.5.4 WIDE WEAR MARKS IN THE CENTRE OF THE BEARING IN THE CIRCUMFERENTIAL DIRECTION

### DESCRIPTION

- Acute wear marks in the centre of the bearing in the circumferential direction
- Less worn bearing edges
- Local material displacement in circumferential direction
- In severe cases: signs of material fatigue and initial rubbing marks visible



**Lower main bearing shell  
steel-aluminium composite**

Clear wear marks in the centre of the bearing which taper off towards the relief can be identified. They are already noticeable as initial rubbing marks in the sliding layer.

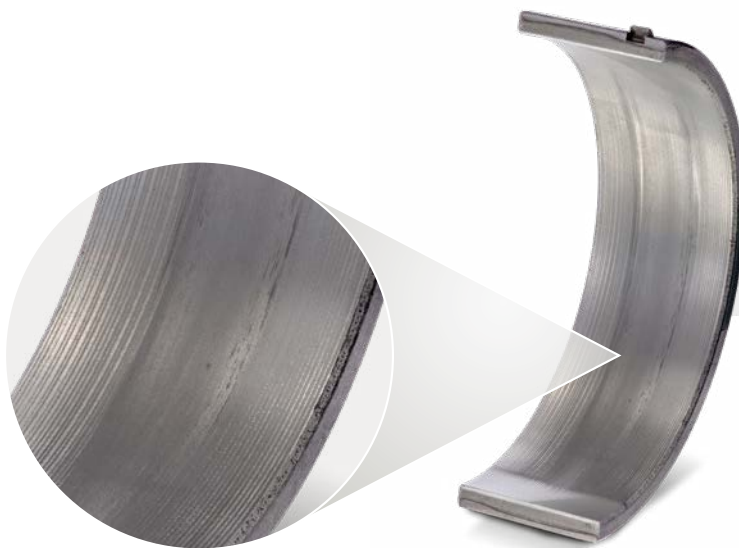

**Lower main bearing shell  
steel-aluminium composite**

Here, a strong wear pattern in the centre of the bearing which tapers off towards the relief can be identified. In terms of form, the wear pattern still corresponds to adaptive run-in wear.

## ASSESSMENT

The lubrication gap in the centre of the bearing is too low, meaning that the lubricating film is not fully stable and mixed friction occurs locally. If the shortage of lubrication continues, the temperature increases due to the frictional heat that results.

The shortage of lubrication continues to intensify due to the increasing temperature level. This process reinforces itself until the first initial rubbing marks and fatigue damage occur in this area due to increased surface pressure.

---

## POSSIBLE CAUSES

- Journal shape that is too strongly convex (Fig. 1)
- Convex bearing bore (Fig. 2)
- Shortage of lubricant

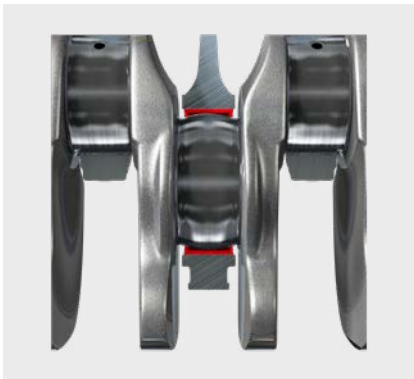

Fig. 1: Journal shape that is too strongly convex

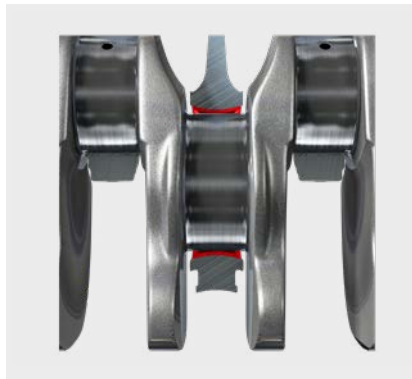

Fig. 2: Convex bearing bore

---

## REMEDY

The bearings can continue to be used depending on their wear condition. They should be replaced as soon as initial rubbing marks develop or indicators of material fatigue become visible and measures to determine the cause should be taken:

- Check for correct geometry of the crankshaft: dimensions, roundness, cylindricity, ripple, surface roughness
- Check the bearing line bore is correct: dimensions, roundness, cylindricity, surface
- Balance crankshaft during installation and check strain on the shaft
- Check alignment of the main bearing bore: during assembly of an engine, always make sure to use the specified tightening torques and bolt tightening sequence – the engine must be sufficiently cooled during operation as deformations may also occur due to temperatures that are too high
- Check connecting rods for angularity before installation
- Check lubrication system (see chapter: „2.3 Initial rubbing marks“)

## 2.5.5 STRIPE-LIKE WEAR IN THE CENTRE OF THE BEARING

### DESCRIPTION

- Stripe-like wear in the centre of the bearing as a continuation of the oil groove – in both bearing shells in the area of the oil bore on the journal in the case of connecting rod bearings
- Sometimes with circumferential scratches
- Less worn bearing edges
- Highly localised zone of wear
- In severe cases: signs of material fatigue and initial rubbing marks visible

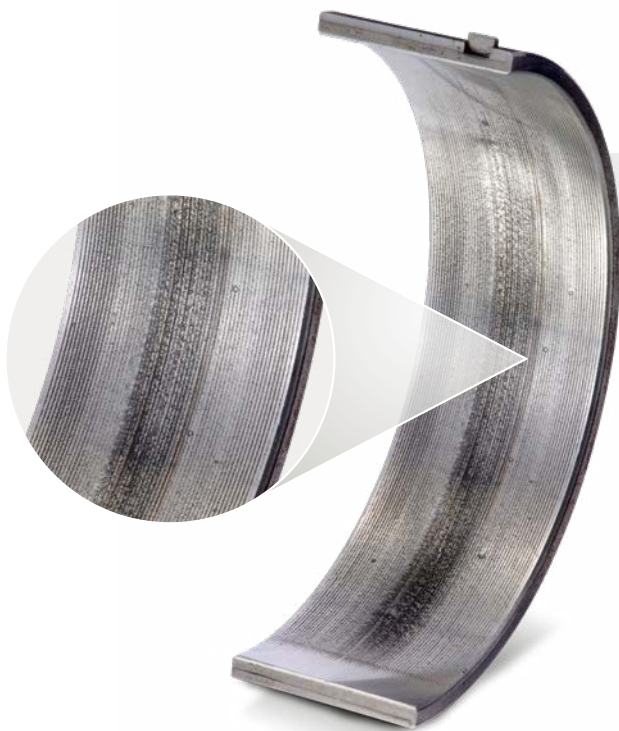

**Lower main bearing shell  
steel-aluminium composite**

Clearly delineated stripes can be seen in the centre of the bearing. This corresponds to the shape of the oil groove which is in the upper main bearing shell. The wear marks occur in the form of adaptive run-in wear.

### ASSESSMENT

This type of wear may be due to a lacking or insufficiently rounded oil bore (Fig. 1). With this in mind, the wear in the lower bearing shell in main bearings or in both bearing shells in connecting rod bearings is very pronounced in the area of the oil bore on the journal.

A second way in which wear arises that can lead to the same damage symptoms is ridge wear (Fig. 2). This results from the lower journal wear in the area of the oil groove.

Since there is no metallic contact between the journal and bearing due to the oil groove, no material removal takes place and a ridge forms on the journal. This ridge leads to stripe-like wear in the bearing shell without an oil groove.

Both processes can lead to initial rubbing marks and fatigue damage.

## POSSIBLE CAUSES

- Lacking or insufficiently rounded oil bore (Fig. 1)
- Unfavourable material combination of the bearing and journal leads to lower journal wear in the area of the oil groove (Fig. 2)

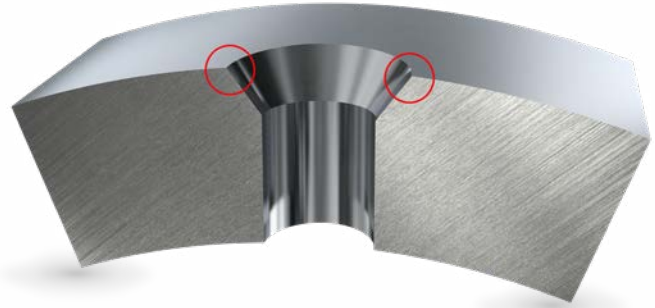

Fig. 1: Lacking or insufficiently rounded oil bore

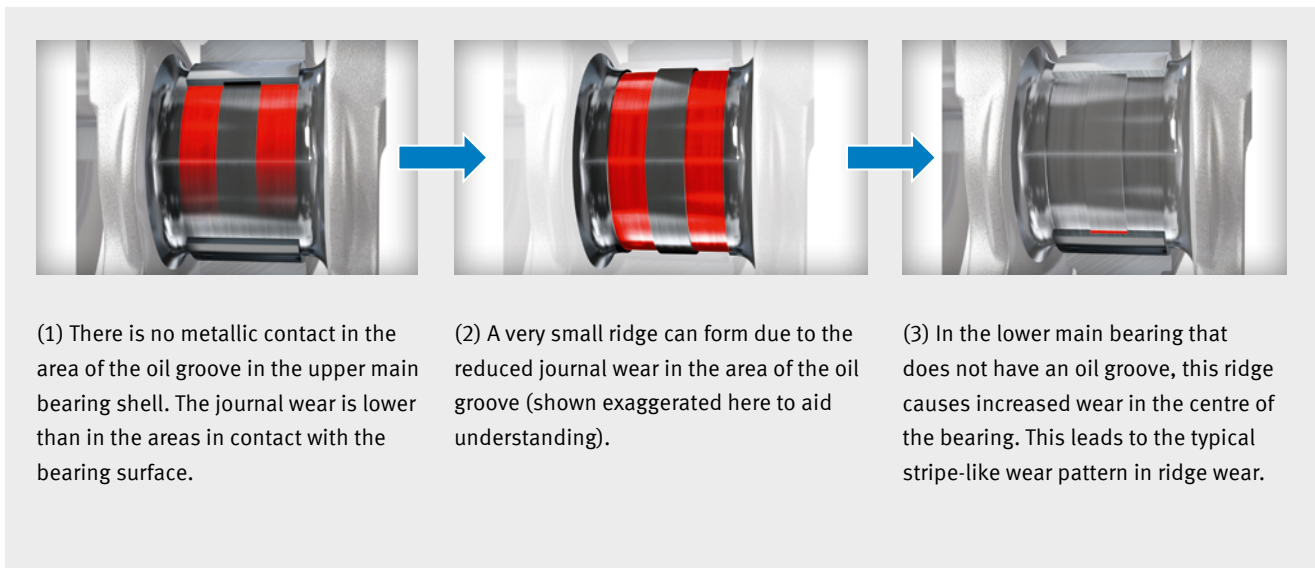

Fig. 2: Unfavourable material combination of the bearing and journal

## REMEDY

The bearings can continue to be used depending on their wear condition. They should be replaced as soon as initial rubbing marks develop or indicators of material fatigue become visible and measures to determine the cause should be taken:

- Check and reworking of the oil bore outlet
- Check shaft journals for ridges in the area of the oil groove
- Check material combination of the journal and bearing (hardness of shaft / bearing)
- Check roughness of the journal

## 2.5.6 WEAR ON OPPOSING AREAS OF THE SEPARATION PLANES

### DESCRIPTION

- Significant wear marks in the area of the diagonally opposite reliefs
- Crown of the bearing shell significantly less worn
- In severe cases: signs of material fatigue and initial rubbing marks visible



**Lower main bearing shell  
steel-aluminium composite**

Pronounced wear is visible in the relief, whilst the bearing crown is considerably less worn.

## ASSESSMENT

If the bearing shells in this area carry weight, the fault is severe. Misalignment of the bearing shells to one another due to an installation error can be the cause for the wear that occurs. The bearing clearance is too low locally due to the cover offset, meaning that the lubricating film is not fully stable and mixed friction occurs in places. If the shortage of lubrication continues, the temperature increases due to the frictional heat that results.

The shortage of lubrication continues to intensify due to the increasing temperature level and the process reinforces itself until the first initial rubbing marks occur and fatigue damage occurs due to increased surface pressure.

---

## POSSIBLE CAUSES

- Wrong bearing cap installed
- Bearing cap installed twisted by 180 degrees
- Unsuitable tool or wrong locating bolts used
- Wrong tightening sequence or wrong tightening torque of the bolts

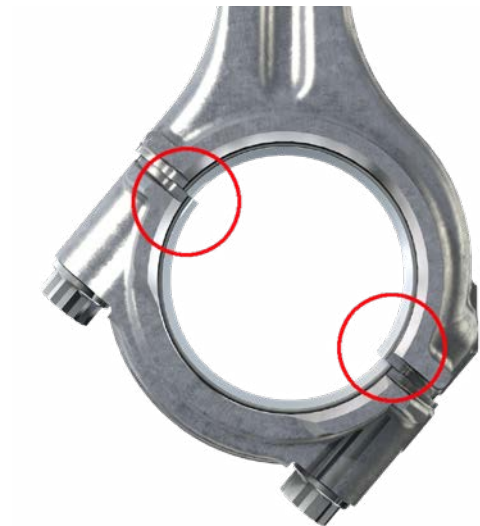

---

## REMEDY

The bearing must be replaced and the cause rectified as the bearing is not designed to carry weight in this area:

- Pay attention to the relation of the bearing shells to the cylinder
- Only mount suitable bolts with an appropriate tool
- Tighten bolts in accordance with the manufacturer's specifications with regard to tightening torques and the tightening sequence
- Check bore: dimensions, roundness, cylindricity, surface must be within certain specified tolerances

## 2.5.7 TWO-SIDED WEAR ON AREAS OF THE SEPARATION PLANES

### DESCRIPTION

- Significant wear marks in the area of both reliefs on the upper and lower shell
- Crowns of the bearing shells significantly less worn
- In severe cases: signs of material fatigue and initial rubbing marks visible



**Lower main bearing shell  
steel-aluminium composite**

Very pronounced wear marks can be recognised on both sides in the area of the separation planes. The crown / main load area of the bearing shell is, however, considerably less worn.



## ASSESSMENT

If the bearing shells in this area carry weight, the fault is severe. This appearance can be caused by a vertical oval bore. This reduces the bearing clearance in the area of the parting face meaning that the lubricating film is not fully stable and mixed friction occurs in the reliefs. If the shortage of lubrication continues, the temperature increases due to the frictional heat that results.

The shortage of lubrication continues to intensify due to the increasing temperature level and the process reinforces itself until the first initial rubbing marks occur and fatigue damage occurs in this area due to increased surface pressure.

---

## POSSIBLE CAUSES

- Oval deformation of the bearing bore due to thermal or mechanical stress
- Connecting rod with oval connecting rod eye – connecting rods that have already been used have been reinstalled without the reworking required
- Wrong bolt tightening when boring the bore



---

## REMEDY

- Check stress on the bearing bore
- Check bore: dimensions, roundness, cylindricity, surface must be within certain tolerances – rework used parts before reinstalling if necessary
- Tighten bolts in accordance with the manufacturer's specifications with regard to tightening torques and the tightening sequence

## 2.5.8 NARROW ZONE OF WEAR IN THE CROWN OF THE BEARING SHELL

### DESCRIPTION

- Narrow wear marks in the shell crown
- More pronounced in the shell that receives most stress
- In severe cases: signs of material fatigue and initial rubbing marks visible



**Upper main bearing shell  
steel-aluminium composite**

Wear marks in the area of the crown in the form of adaptive run-in wear can be recognised. No other operating marks are visible in other parts of the bearing sliding surfaces.

## ASSESSMENT

This appearance is caused by a horizontal oval bore. This reduces the bearing clearance in the crown meaning that the lubricating film is not fully stable and mixed friction occurs in places. If the shortage of lubrication continues, the temperature increases due to the frictional heat that results.

The shortage of lubrication continues to intensify due to the increasing temperature level and the process reinforces itself until the first initial rubbing marks occur and fatigue damage occurs in this area due to increased surface pressure.

---

## POSSIBLE CAUSES

- Placement of the connecting rod or the housing striking faces
- Wrong bolt tightening when boring the bore
- Extreme connecting rod pressure load



---

## REMEDY

- Check the bearing line bore is correct: dimensions, roundness, cylindricity, surface
- Tighten bolts in accordance with the manufacturer's specifications with regard to tightening torques and the tightening sequence
- Check stress on the connecting rod

## 2.5.9 NARROW, WEAR-FREE STRIPS AT THE EDGES OF THE BEARINGS

### DESCRIPTION

- Narrow, wear-free strips at the edges of the bearings
- No run-in marks visible in this area
- Machining structure from production still recognisable in this area
- Clear definition between the wear-free strips and the worn area recognisable

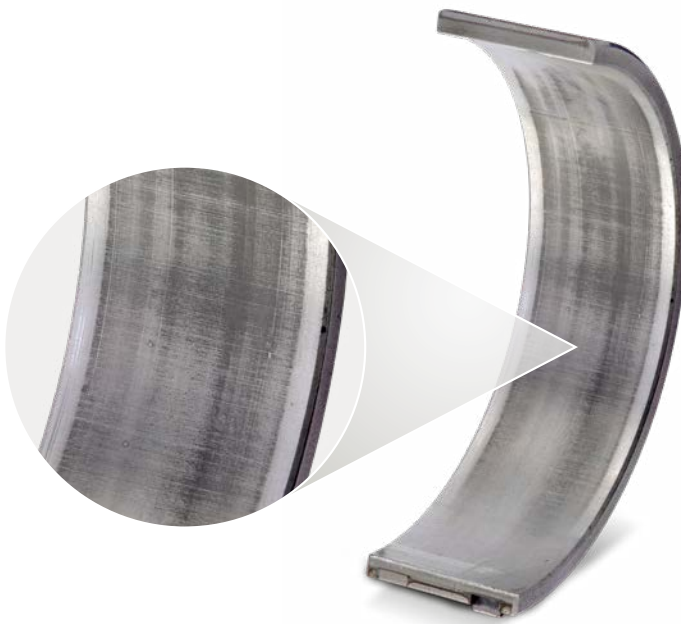

**Lower main bearing shell  
steel-aluminium composite**

Two wear-free strips are recognisable at the edges of the bearings without any visible wear marks. The remaining part of the bearing has a slight black discoloration, possibly due to corrosion or wear.

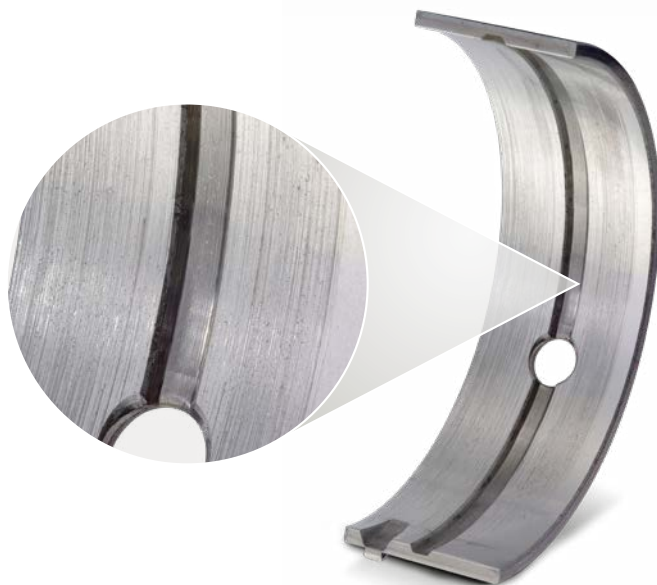

**Upper main bearing shell  
steel-aluminium composite**

One wear-free strip is recognisable at the edges of the bearings without any visible wear marks. The remaining part of the bearing has pronounced scoring.

## ASSESSMENT

Due to one-sided (Fig. 1) or two-sided (Fig. 2) axial protrusion of the bearing shells, narrow, wear-free strips at the edges of the bearings are formed, which also do not demonstrate the typical adaptive run-in wear. Irrespective of the speed of the journal, there is never any metallic contact in these areas.

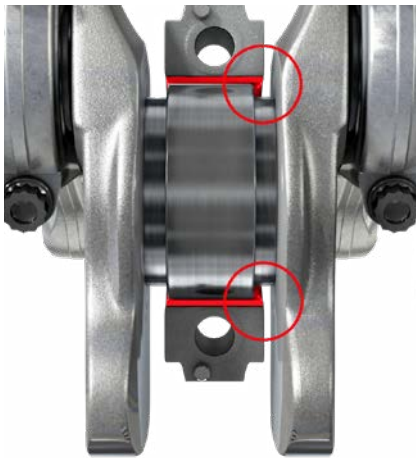

Fig. 1: One-sided axial protrusion

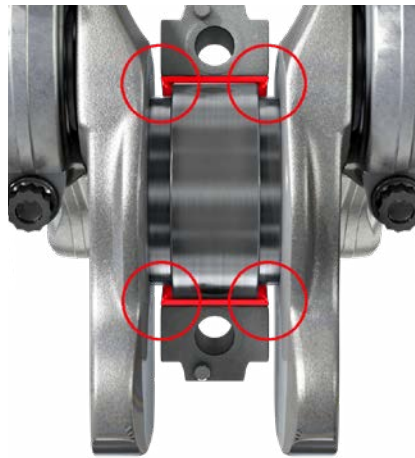

Fig. 2: Two-sided axial protrusion

---

## POSSIBLE CAUSES

- Geometric deviations of the journal
- Incorrect choice of bearing width
- Clearance (shaft / journal misalignment)

---

## REMEDY

The bearings can continue to be used depending on their wear condition. They should be replaced as soon as initial rubbing marks develop or indicators of material fatigue become visible and measures to determine the cause should be taken:

- Check for correct geometry of the crankshaft before installation: dimensions, roundness
- Replace the crankshaft or install new bearings which fit the crankshaft geometry

# 3. DAMAGE DUE TO THE INFLUENCE OF PARTICLES

## 3.1 INTRODUCTION

When foreign particles find their way into the lubrication gap between the bearing and the shaft journal, there is a great risk of bearing damage. Due to the very low thickness of the lubricating film, even small particles may disrupt operation and cause mixed friction. They may become embedded in the sliding layer and therefore made „harmless“. The edges created in the process are flattened during contact with the shaft. Particles which are larger than the thickness of the sliding layer cannot be completely embedded. The protruding part causes wear of the shaft journal in the form of grooves. Strongly pronounced grooves lower the expected service life and may promote bearing seizure.

Even during production or reconditioning of an engine, particles can enter the engine block and become stuck. This may be the case, for example, during the sand or glass blasting of an engine block. Dirt particles may also „arise“ during operation, however (for example, soot or carbon), or be introduced.

Inadequate maintenance of the lubricating system or extreme external influences also promote the intake of dirt into the lubricant circuit. Damaged adjacent bearings or other damaged engine components can also introduce particles into the oil circuit.

Generally, the danger of damage due to the influence of particles in the main bearing is greater than in the connecting rod bearing. Connecting rod bearings are supplied with oil from the main bearings via holes in the crankshaft, meaning that the oil first runs through the main bearings. Larger particles are embedded in the main bearing and so generally do not reach the connecting rod bearing.

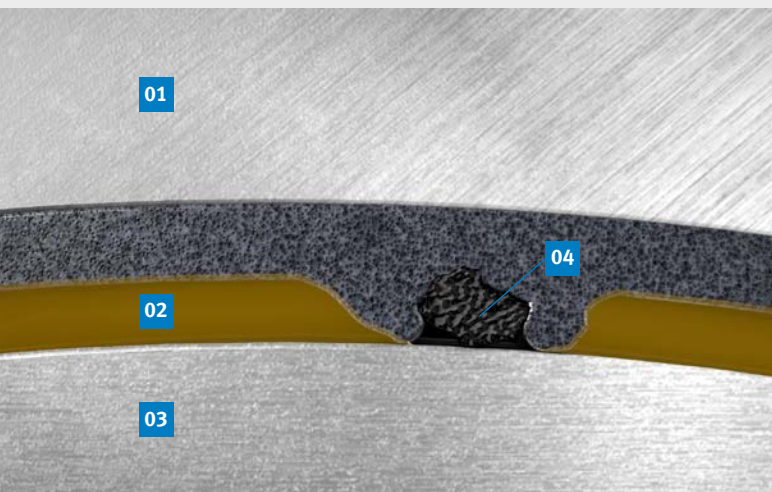

- 01 Steel back
- 02 Oil film
- 03 Shaft
- 04 Particle



To gain an insight into where the particles have come from, it may be useful to analyse the bearing and a sample of the oil.

### POSSIBLE CAUSES

- Mounting was not clean: due to carelessness or inadequate cleaning of the engine components during mounting, dirt may enter the engine block
- Residues such as metal chips or residual blasting agent from production or reconditioning may form deposits in the engine block which then come away during operation – often these are also deposits from attachments, such as the oil cooler, which were not cleaned adequately during the engine reconditioning
- Damage to the seals in the area of the engine: if a seal is excessively stressed or damaged during installation, it no longer fulfils its function and particles can enter the system
- Lack of maintenance of the lubricant system: inspection intervals that have been exceeded or blocked oil filters may cause an increase in dirt in the oil
- Cavitation: particles are broken off of the bearing material and carried on by the oil – depending on the size, these may cause scoring or fine embedding in the bearing or in the adjacent bearing
- Seizure: seized engine components (pistons, bearing shells) cause numerous particles to enter the lubricant circuit, which in turn can cause damage to other components
- Fatigue damage: if material has broken off of engine components, this broken-off material can be further carried by the oil into the bearings and can cause damage here

---

### REMEDY

Generally, despite scoring or embedded particles, bearings can still be used. This depends on the extent of the damage, however. If, for example, there are numerous large indents from particles with initial marks of mixed friction due to material accumulation, it is advisable to replace the bearing. Fine particle indents do not impair the function of the bearing. In both cases, the cause should be clarified in any case:

- Cleaning of all components before mounting: it is important to rinse out all of the oil bores in the shaft and housing before initial start-up. It is also important that the bearing seats are cleaned so that small chips and particles from production and / or reconditioning are removed – the oil channels of attachments, such as oil cooler and turbocharger, must also be thoroughly cleaned
- Check the seals for functionality
- Always replace the oil filter and oil according to the manufacturer's specifications: ensure that the inspection intervals are complied with and only oil and oil filters to the right standard are used
- Filtering of the intake air: service the filters regularly; replace if necessary
- Check other engine components for damage such as cavitation, fatigue or seizure – engine bearing damage due to the influence of particles is often consequential damage
- If the influence of particles cannot be ascertained, the analysis of damaged bearing shells and an oil sample may provide an insight: if particles are still embedded in the bearing or present in the oil, their chemical composition can be determined – if it is a case of material from the crankshaft, for example, a more precise check for damage can be carried out here

## 3.2 SCORING

### DESCRIPTION

- Stroke-like recesses in the sliding direction with material accumulation at the edges
- The areas of material accumulation are partially levelled out again due to wear, bright and light
- Generally in line with scoring or embedded particles in the crankshaft or adjacent bearings

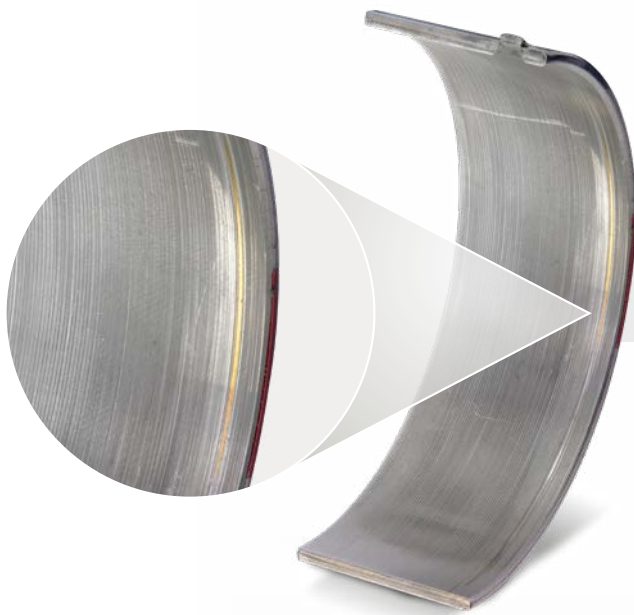

**Rod-side conrod bearing shell  
steel-brass composite with  
sputter coating**

The groove extends up to the brass layer.  
Light wear marks occur next to the scoring  
due to smoothed material accumulation.

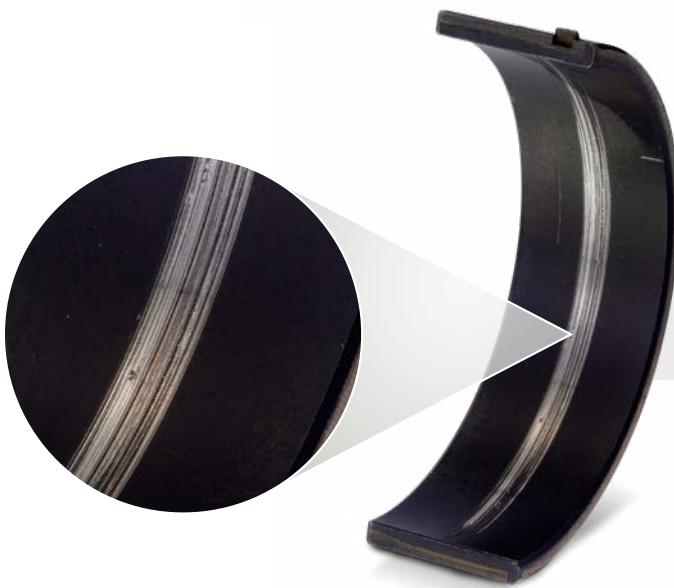

**Lower main bearing shell  
steel-aluminium composite  
with polymer coating**

The grooves are worn up to the aluminium  
alloy layer.



## ASSESSMENT

Particles which find their way into the lubricant gap and are not embedded into the bearing material are repeatedly forced through the gap, causing grooves in the process. Depending on the thickness of the edges created, these cannot be flattened during further operation and, due to increased mixed friction, there is an increase in temperature in the event of shaft contact.

This often leads to initial rubbing marks and seizure. The scoring may also be the result of the influence of mixed friction. Here, the grooves are fine and formed on the surface, however, and appear at both interacting sliding parts.

---

## REMEDY

If grooves with pronounced material accumulation are present at the edges, the bearing must be replaced. If grooves are present with areas of material accumulation which have been flattened, and no further influence of particles can be expected, the bearings can still be used.

## 3.3 EMBEDDING

### DESCRIPTION

- Scarred surface
- Particle imprints (still containing particles in places), surrounded by material accumulation which is visible as a light shining point due to wear
- Often in conjunction with scoring in the journal and bearing
- In severe cases, initial rubbing marks from the embedding are visible

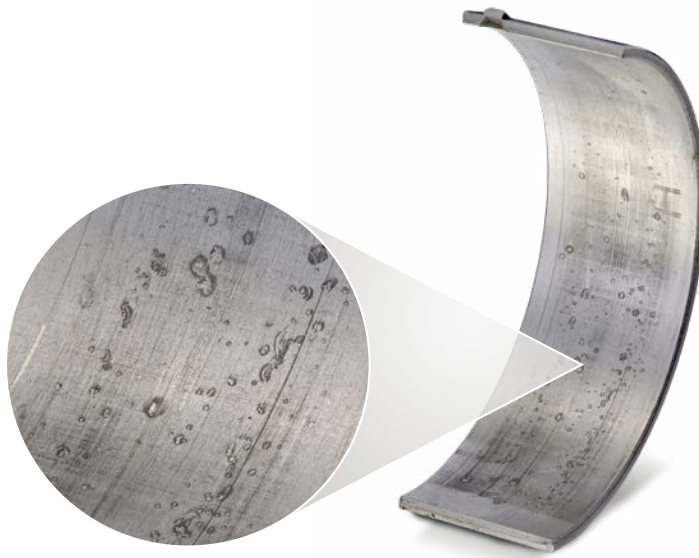

**Cap-side conrod bearing shell  
steel-aluminium composite**

Fine particle imprints and individual scoring marks are visible.

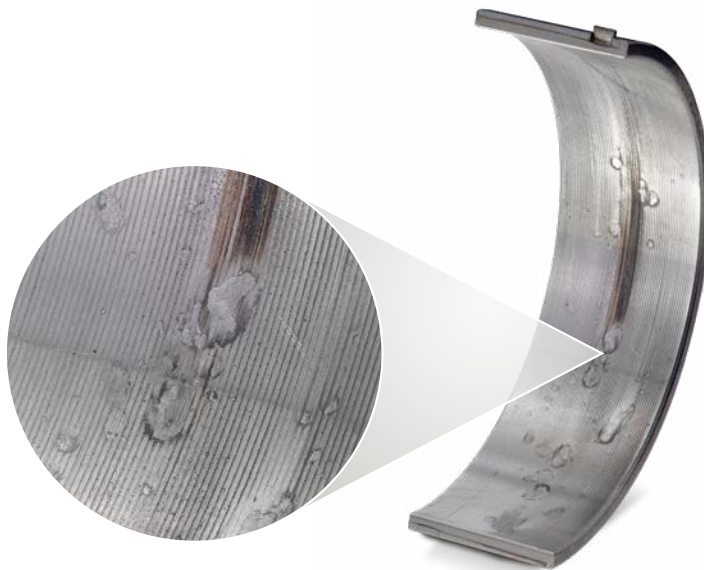

**Lower main bearing shell  
steel-aluminium composite**

Large particle imprints without embedded particles are visible. The particles have caused areas of material accumulation which have caused an initial rubbing mark in the centre of the bearing.

## ASSESSMENT

Particles which find their way into the lubricant gap may become embedded in the bearing material. Depending on the thickness of the sliding layer, we can differentiate between deep and shallow embedding. In the case of deep embedding, the particles are completely integrated into the sliding layer. This is only possible when the particle is smaller than the thickness of the layer. The material accumulation created during the embedding is flattened during the subsequent contact with the shaft due to wear. Shallow embedding takes place when the size of the particle is greater than the thickness of the layer. The particles are not completely embedded and protrude from the bearing surface. They cause wear and scoring on the journal surface.

Due to the material accumulations at the edges or protrusions from particles which are not completely embedded, the formation of the lubricant film is disrupted, and mixed friction conditions may be created. So-called „wire-wool“ wear is a possible consequence. Here the embedded particles cut into the surface of the shaft and remove material (chipping wool). The particles that break away, which are then embedded again, accelerate the bearing damage, and often complete failure of the journal and bearing cannot be avoided.

Initial rubbing marks and seizure can therefore result from particle embedding.

---

## REMEDY

If large particle embedding in conjunction with initial wear of the journal and bearing is present, the bearing must be replaced.

If fine particle embedding is present, the material accumulation of which has been flattened and no further influence of particles can be expected, the function of the bearing is not impaired.

## 3.4 DIRT PROGRESSION MARKS

### DESCRIPTION

- Individual indents, one after the other, are arranged in tracks.  
At the end of these, there may still be particles embedded
- They generally run diagonally to the edge of the bearing
- Starting from the oil groove or lubricating holes
- Often in conjunction with scoring in the journal and scoring / particle embedding in the bearing



**Lower main bearing shell  
steel-aluminium composite**

A dirt progression mark, starting from the parting face, has occurred. Several large particle indents one after the other – running diagonally – are visible. Particles which are still embedded may be present in part.

**ASSESSMENT**

Very large and hard particles which find their way into the lubricant gap cannot become embedded in the bearing material. They are forced through the lubricating gap, but then always become stuck again. Frequently, the pattern appears from oil grooves or oil bores as the particles were introduced here. Pronounced material accumulation along the progression track causes initial rubbing marks and seizure.

---

**REMEDY**

If there are pronounced areas of material accumulation along the progression track, or signs of an initial rubbing mark, the bearing must be replaced. The bearings can still be used, however, if the material accumulations have been flattened and there is no longer the risk of the influence of particles.

## 3.5 FOREIGN PARTICLES ON BEARING BACK

### DESCRIPTION

- Locally limited deviation of the wear pattern
- Light wear point in the sliding surface
- Often particle residues / imprints on the steel back of the bearing
- In severe cases pronounced marks of mixed friction in the form of initial rubbing marks and signs of material fatigue in the bearing sliding surface are visible



**Lower main bearing shell  
steel-aluminium composite**

A clear deviation in the wear pattern, as well as point-like wear in the sliding surface can be recognised. The pressure mark is the result of particles at the back of the bearing.



Back of the bearing

## ASSESSMENT

Due to dirt or oil residues (carbon) at the back of the bearing, local pressure points arise, which become noticeable on the bearing sliding surface. Due to the pressure, on the inside of the bearing there is increased wear compared to the remaining areas of the bearing. This can be recognised as a noticeable, mostly bright light deviation to the wear mark. Depending on the extent of the pressure points, initial rubbing marks and seizure, as well as fatigue damage, may be the result.

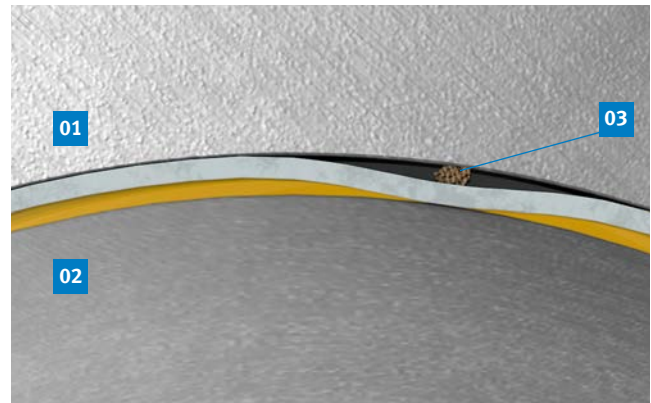

- 01 Housing
- 02 Shaft
- 03 Particle

---

## REMEDY

Whether the bearing can still be used depends on the progress of the wear of the sliding layer. As soon as initial rubbing marks or signs of material fatigue such as cracks or nicks in the area of the pressure point occur, the bearing should be replaced, otherwise there is the threat of complete failure. Broken-off material can cause consequential damage in the same or an adjacent bearing.

# 4. EROSION AND CAVITATION

## 4.1 EROSION

### DESCRIPTION

- Fine scoring in the direction of the oil flow
- Roughening and fissures of the sliding layer

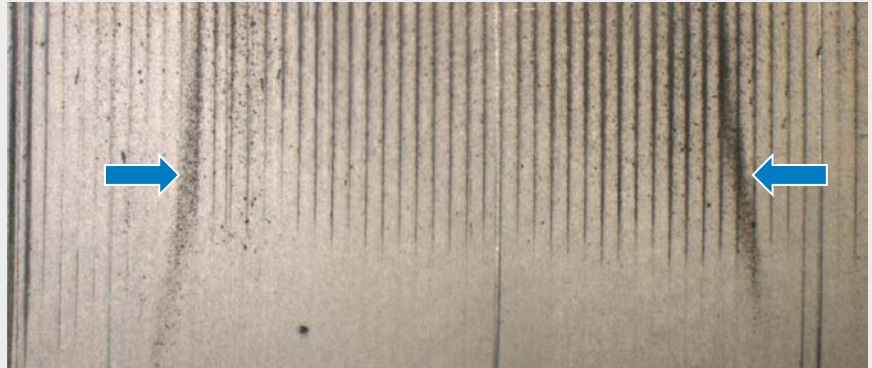

### ASSESSMENT

Erosion is a form of abrasive material removal, caused by the flow forces of the oil. This effect is reinforced by the smallest particles in the oil, such as carbon deposits or deposits from abrasion. Erosion is also often the result of cavitation, as here particles from the material are broken off and enter into the lubrication system.

Erosion attacks the material surface and activates it chemically, accelerating the initial corrosion.

The integrity of the material is also influenced negatively as the fissures on the surface can cause cracks. Damage caused by fatigue is the result.

Due to the use of thin oils, erosion is occurring more and more frequently.

### POSSIBLE CAUSES

- High speeds and low bearing clearance
- Use of incorrect engine oils with, for example, the incorrect additives or without additives at all
- Smallest particles in the oil flow: particles may come from different areas of the engine and may have been caused by incomplete combustion or cavitation, for example

### REMEDY

- Keep the temperature of the oil low through sufficient cooling
- Always replace the oil filter and oil according to the manufacturer's specifications: ensure that the inspection intervals are complied with and only oil and oil filters to the right standard are used



## 4.2 CAVITATION

Cavitation is caused by the flow of the lubricant through the bearing gap. The vapour pressure of the oil used plays a crucial role here.

Seen correctly, cavitation is merely the physical process of the fuel vapour lock of a liquid, which in itself does not cause any damage to the bearing. The corresponding damage symptoms describe cavitation erosion through the material removal typical for this, as a result of the implosion of the vapour bubbles in areas below the vapour pressure (cavitation  $\leftrightarrow$  cavitation erosion).

Despite the different ways in which they are created, for some damage symptoms it can be difficult to differentiate between cavitation, erosion and corrosion. Often, complex transitional forms also appear such as cavitation erosion or erosion corrosion. This can be explained by the fact that both cavitation and erosion attack anti-corrosion layers, activate these chemically, resulting in corrosion.

### DESCRIPTION

If the vapour pressure of the oil used is not reached, gas and vapour bubbles form which are transported further by the flow. This is known as cavitation. When the static pressure continues to increase, these bubbles collapse like an implosion, resulting in strong pressure surges – so-called microjets – as well as high temperatures. The pressure surges cause the material to break off and cause material removal, i.e. cavitation erosion.

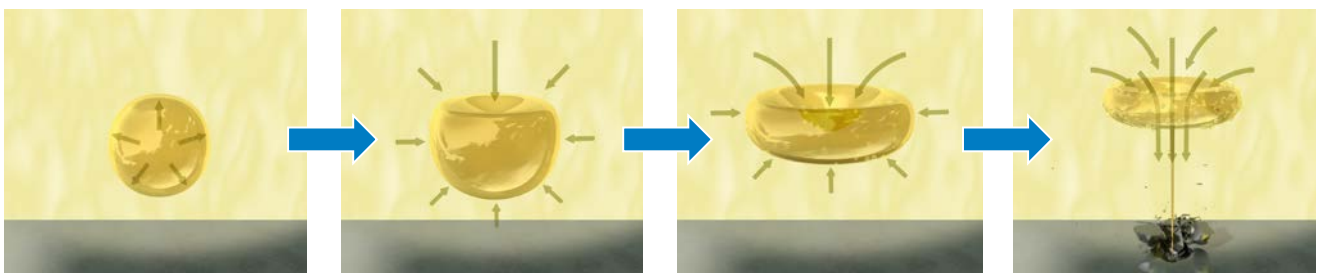

Cavitation bubble is formed and grows

Implosion begins

Microjet is formed

Microjet breaks through the cavitation bubble and hits the surface

## DESCRIPTION

- Cavitation in the relief: pointed or mushroom-shaped nick in the relief towards the parting face. The area is clearly roughened and matte
- Cavitation in the run-out of the oil groove: mushroom-shaped nick in the run-out of the oil groove, roughened and matte area

Cavitation may also occur in other areas of the bearing, such as in the crown. These forms are, however, much harder to differentiate from erosion and corrosion. Generally, you do not find material nicks such as with the forms mentioned above, but instead matte, slightly roughened areas which could also be the result of erosion or corrosion.

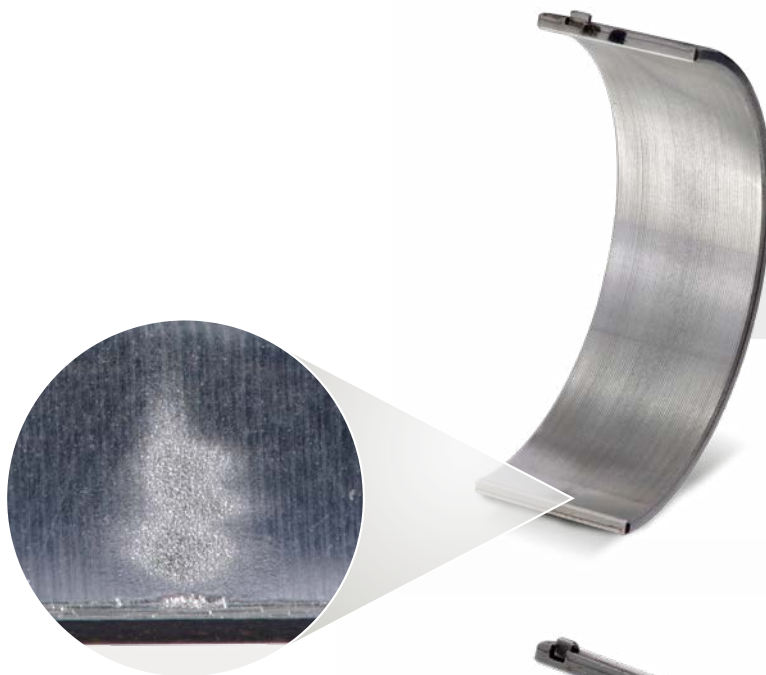

**Cap-side conrod bearing shell  
steel-aluminium composite**

Cavitation in the relief: material removal can clearly be seen – the area is matte compared to the surrounding material.



**Upper main bearing shells  
steel-aluminium composite**

Cavitation in the run-out of the oil groove: a mushroom-shaped nick in the bearing material can be seen. The area is much more matte and roughened compared to the surrounding material.

## ASSESSMENT

Pressure surges caused by the implosion of gas and vapour bubbles near to the surface of the bearing result in material nicks (see chapter: „4. Erosion and cavitation“). Cavitation often comes hand-in-hand with erosion and corrosion and can cause fine scoring in the same or adjacent bearings.

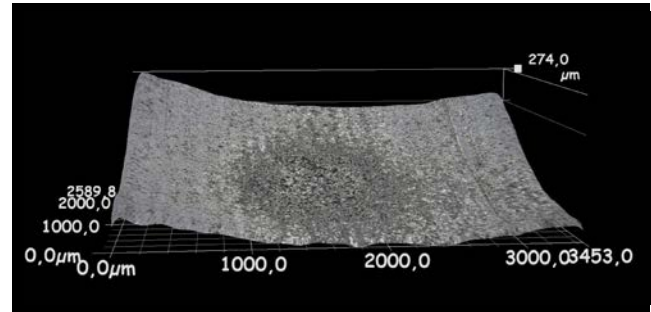

3D measurement – cavitation

## POSSIBLE CAUSES

High temperatures and low-boiling impurities may advance cavitation.

- Impurities in the oil: water, fuel or deposits from abrasion and dirt
- Oil pressure that is too low: unforeseen loss of pressure (for example due to defective oil pump) is present or the oil pressure is set too low
- The vapour pressure of the oil used is too low
- Increase in temperature in the bearing (for example due to a lack of oil)
- Oils with low viscosity increase the risk of cavitation
- Hollow areas / foreign particles (for example carbon deposits) at the back of the bearing may cause vibration of the bearing shell, resulting in cavitation

Vibration or suction cavitation:

- Lubrication gap is too large, causing the hydrodynamic pressure in the bearing gap to fall
- Crankshaft vibration: journal movement causes a reduction in pressure on one side due to resulting suction effect
- Vibration in the bearing bore (generally for connecting rod eyes) due to deformation or bending – resulting in a reduction in pressure in the oil film

Flow cavitation:

- Breaks in the surface (oil bores, oil grooves) and diversion of the oil flow may cause a reduction in pressure

## REMEDY

Bearings which demonstrate cavitation do not need to be replaced. Depending on the extent of the cavitation, the service life may be reduced due to the influence on the dynamics of the bearing. Complete failure is not a concern, however.

- Use quality oils and replace the oil and filter regularly in accordance with the manufacturer's specifications
- Check the oil pressure and readjust if necessary
- Use an oil with a higher vapour pressure: the oil must be compatible with all engine components, however. Consult the manufacturer for advice if necessary

- Check the lubricating gap and readjust bearing clearance if necessary
- Check the engine for vibration stress
- Check the oil for fuel dilution

# 5. FATIGUE DAMAGE

## 5.1 INTRODUCTION

If the integrity of the material is exceeded locally, fatigue occurs. The first cracks form (Fig. 1), which continue to grow due to notch effect and a network of cracks develops (Fig. 2). In addition, nicks occur (Fig. 3) in the bearing metal. The network of cracks and the nicks reduce the strength of the bearing, meaning a fatigue fracture can be caused in the event of stress. The engine bearing has then lost its ability to function and complete failure occurs.

Particles enter the lubrication system due to the material breaking off. This can result in scoring or the embedding of particles in the same or adjacent bearing shells. Initial rubbing marks and seizure can also be caused in the same or adjacent bearings.

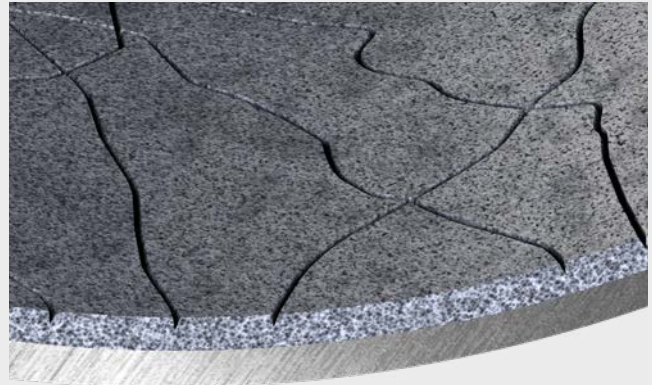

Fig. 1: First cracks

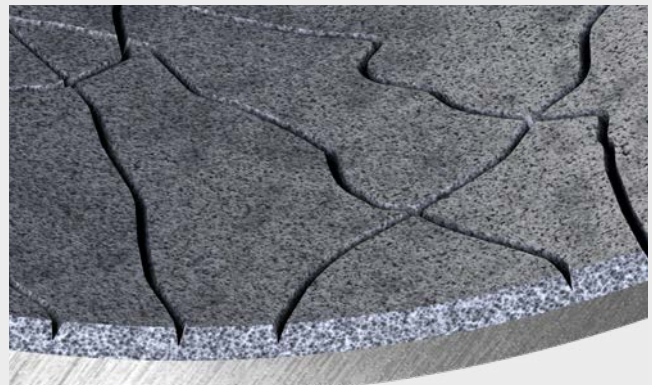

Fig. 2: Network of cracks

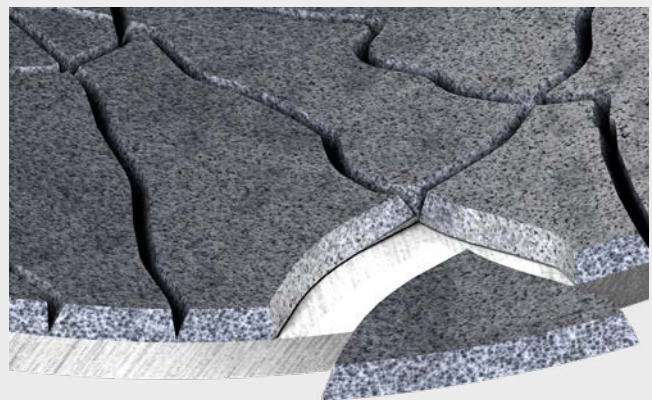

Fig. 3: Nicks

## POSSIBLE CAUSES

Signs of fatigue, such as cracks and nicks on the bearing metal, are caused by dynamic overstrain. This can have various causes:

- Overstressing: if forces larger than the design allows for affect the bearing, material fatigue occurs – combustion defaults, such as knocking, increase the pressure on the piston and therefore also on the connecting rod bearing
- Lubrication gap dimensioned too small – a stable lubricating film cannot form: the lubricating film pressure rises in these locations and the surface pressure increases – this can be caused by misalignment, formal errors, errors in geometry or installation errors (see chapter: „2.5 Special cases“) – inspection of the adjacent bearing can provide more information
- Poor oil quality or oil ageing: if unsuitable oil is used or the oil is not of a sufficient quality due to ageing, this can impair the formation of the lubricating film
- Vibrations: if the bearing is subject to alternating tensions due to vibrations, the risk of material fatigue increases
- High temperatures: material fatigue is accelerated by high temperatures since they reduce the strength of the bearing material

---

## REMEDY

- Check stress of the bearings – if necessary, a bearing that is more resistant to fatigue must be used
- Check for correct geometry of the crankshaft: dimensions, roundness, cylindricity, ripple, surface roughness
- Check the bearing line bore is correct: dimensions, roundness, cylindricity, surface
- Check the alignment of the main bearing bore (observe specified tightening torque of the bolts, cool engine sufficiently)
- Check connecting rods for angularity before installation
- Balance crankshaft during installation
- Only use oil recommended by the manufacturer and observe oil change intervals
- Ensure sufficient engine cooling

## 5.2 CRACKS AND NICKS TO THE SLIDING LAYER

This type of damage only occurs with engine bearings with a sliding layer made of polymer / bonded, galvanic or sputter coating.

### DESCRIPTION

- Fine cracks in the sliding layer identifiable: particularly oblique to the direction of movement – is often known as “bark beetle” as the damage symptoms resemble the feeding pattern of a bark beetle
- Often associated with edge wear and discolouration of the bearing surface



**Rod-side conrod bearing shell  
steel-brass composite with  
sputter coating**

The engine bearing demonstrates signs of fatigue towards the relief in the form of cracks and initial nicks up into the brass layer.

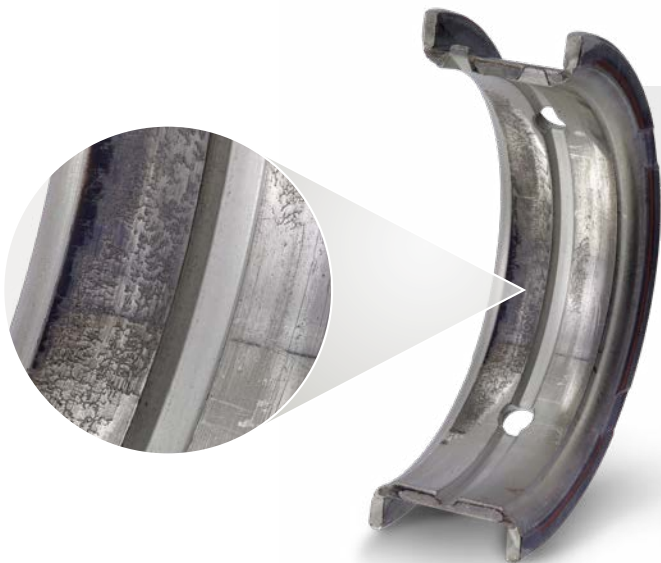

**Main bearing shell  
steel-bronze composite with  
galvanic coating**

One-sided edge wear on both bearing shells caused the fatigue of the galvanic layer and created the typical „bark beetle“ damage pattern.



**For possible causes and remedy  
see chapter „5.1 Introduction“**

## 5.3 CRACKS AND NICKS TO THE BEARING METAL

### DESCRIPTION

- Cracks and cobblestone-like nicks down to the bearing material
- Edges of the nick rounded off due to wear depending on further service life

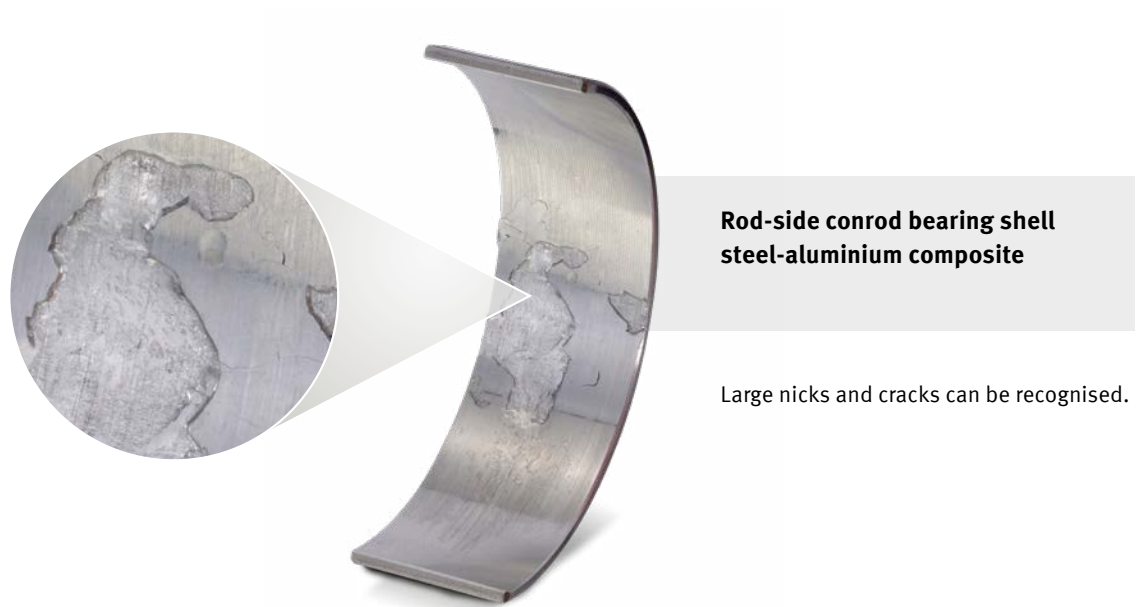

**For possible causes and remedy  
see chapter „5.1 Introduction“**

# 6. OVERHEATING DAMAGE

## 6.1 INTRODUCTION

Overheating damage is the result of dramatic temperature development in the engine bearing shell, which goes hand-in-hand with acute mixed friction. This is why heat cracks, discolouration and fusing are also always displayed for initial rubbing marks or seizure.

The heat dissipation provided by the lubricant plays a central role here. If heat dissipation is no longer provided, this causes complete failure. Even with the initial signs of overheating, local changes to the microstructure occur and the integrity of the material is reduced. Heat cracks form at the affected areas.

---

### POSSIBLE CAUSES

- Consequential damage due to increasing temperature development as a result of initial rubbing marks, seizure or edge wear
- Insufficient heat dissipation provided by the lubricant (see chapter: „2.3 Initial rubbing marks“)

---

### REMEDY

If overheating damage occurs, the bearing must be replaced and the causes investigated. In the event of consequential damage, the cause of the primary damage must be rectified.

If no further damage to the bearing is visible, the lubricant circuit (see chapter: „2.3 Initial rubbing marks“) and the stress on the bearing must be checked.



## 6.2 HEAT CRACKS

### DESCRIPTION

- A network of cracks is visible
- Fusing and discolouration of the bearing shell

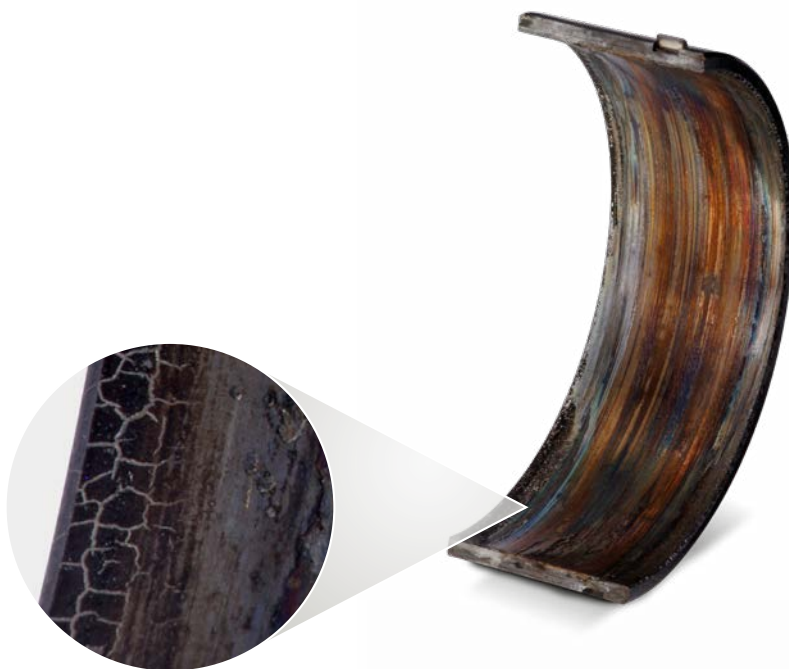

**Cap and rod-side conrod bearing shell steel-bronze composite with galvanic coating**

Clear discolouration and fusion is visible on the sliding layer of the seized bearing shells. The crack formation is above all recognisable in the area of the edge.

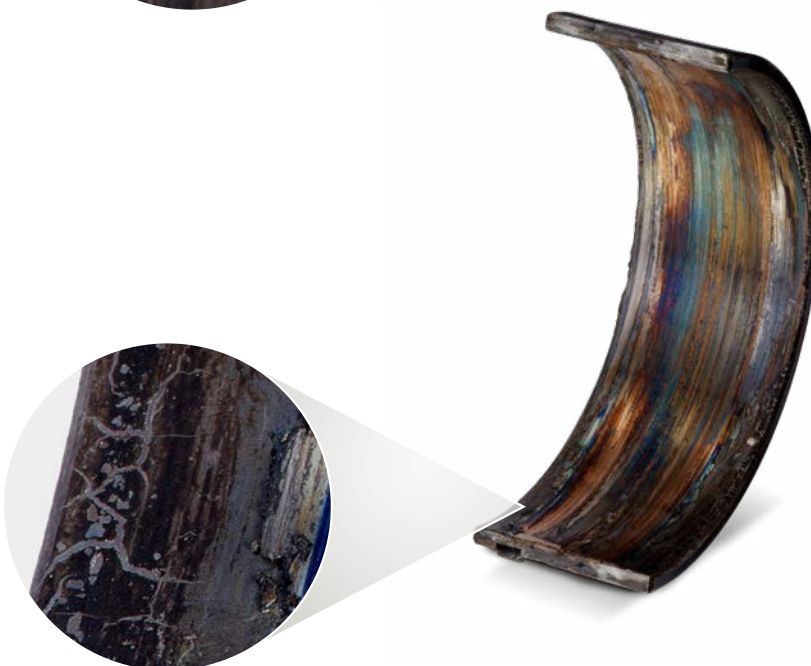

**For possible causes and remedy see chapter „6.1 Introduction“**

## 6.3 FUSING OF THE SLIDING LAYER

### DESCRIPTION

- Material displacement and smearing visible in the sliding surface
- Accompanied by heat cracks and discolouration of the bearing shell



**Cap-side conrod bearing shell  
steel-bronze composite with  
galvanic coating**

White fusion deposits are visible in the galvanic layer.



**For possible causes and remedy  
see chapter „6.1 Introduction“**

## 6.4 DISCOLOURATION OF THE SLIDING LAYER AND / OR THE BACK OF THE BEARING

### DESCRIPTION

- Blue-ish to black discolouration of the sliding layer or on the back of the bearing
- Accompanied by lumps and material removal / displacement



**Rod-side conrod bearing shell  
steel-bronze composite with  
galvanic coating**

Following bearing seizure, the back of the bearing is black in colour.



**Cap-side conrod bearing shell  
steel-bronze composite with  
galvanic coating**

The tarnishing colour can be seen in the sliding layer.



**For possible causes and remedy  
see chapter „6.1 Introduction“**

# 7. CORROSION

## 7.1 FRICTIONAL CORROSION / CONTACT CORROSION

### DESCRIPTION

- Scarred surface of the back of the bearing or in the area of the parting face
- Roughened, matte areas

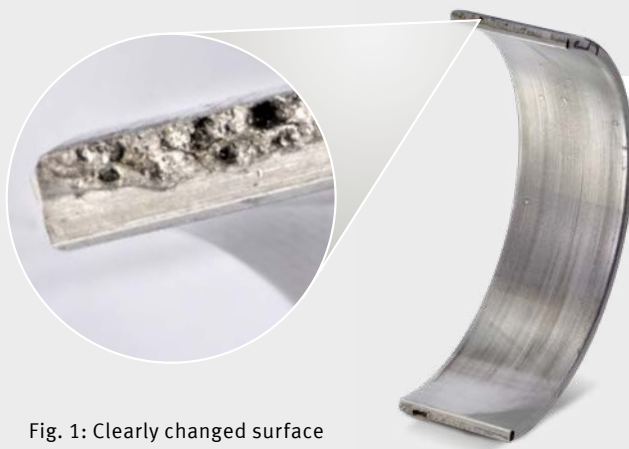

Fig. 1: Clearly changed surface

#### Lower main bearing shell steel-aluminium composite

In the area of the parting face, signs of movement of the bearing shell in the form of frictional corrosion may also be visible. The material surface has clearly changed (Fig. 1).



#### Upper main bearing shells steel-aluminium composite

Clear traces of frictional corrosion can be recognised – in part with areas of torn-out material (Fig. 2).

Here, the clear characteristics of surface frictional corrosion are recognisable: with areas of torn-out material and scarring of the surface (Fig. 3).

Fig. 2: Areas of torn-out material

Fig. 3: Areas of torn-out material and scarring of the surface

## ASSESSMENT

If the bearing shell is not sitting correctly in the bearing block, frictional corrosion is caused due to the resulting relative movement (micro sliding movements). The frictional heat generated by the movement of the bearing cannot be dissipated by the lubricant as in the inside of the bearing, but instead causes local overheating of the steel back. The overheating causes fusing and the scarred surface typical of this. There is a transfer of material between the back of the bearing and the bore.

The surrounding medium can penetrate into the surface (which is already roughened and chemically activated) and accelerate the corrosion.

Frictional corrosion reduces the integrity of the material, as the formation of micro cracks is facilitated. Fatigue damage with consequences such as cracks or fatigue fractures can be the result.

---

## POSSIBLE CAUSES

- Insufficient preloading due to bore being too large or bearing shell being too small
- Bearing shell protrusion too small: the protrusion of the bearing shell guarantees the reliable fit through sufficient press fitting
- Housing deformation: for crankcases made from aluminium, the housing and bearing shell can deform differently under the effect of extreme temperatures, whereby the reliable fit of the bearing may no longer be sufficient
- Bending of the crankshaft: the bending of the crankshaft leaves a particular wear pattern on the sliding surface of the bearing (see chapter: „2.5 Special cases“)
- Insufficiently tightened bolts
- Vibrations from the housing or the crankshaft which cause micro-movements (vibration may also be caused by foreign particles and / or hollow areas)

---

## REMEDY

When the signs of contact corrosion are recognisable, the bearing must be replaced as the integrity may already be reduced.

- Locating hole and bearing shell outer diameter must be within the tolerance range so that the specified bearing clearance can be met
- Protrusion: in order to create the desired press fit for the reliable fit, the bearing shell must have a sufficient protrusion
- Check the locating hole and housing for possible deformation
- Balance crankshaft during installation and check strain on the shaft
- Tighten bolts in accordance with the manufacturer's specifications with regard to tightening torques and the tightening sequence
- Check engine for vibration during operation

## 7.2 CHEMICAL CORROSION

### DESCRIPTION

- Discolouration of the material surface, mainly in the main load area
- Sliding surface rough and porous



**Lower main bearing shell  
steel-aluminium composite**

Deposits from corrosion products are visible in the bearing sliding surface, especially pronounced in the centre of the bearing. The deposits appear in the formation of stains. When studied under a microscope, roughening of the bearing sliding surface can be seen in the corroded area.

## ASSESSMENT

Chemical corrosion is caused by reactions between the bearing shell and engine oil. Triggers for the chemical reaction are aggressive additives in the oil or oil contamination during operation.

The integrity of the material is adversely affected by the chemical attack, meaning that fatigue damage is accelerated, even with low stress.

---

## POSSIBLE CAUSES

- Wear, cavitation and erosion can assist corrosion since they attack the material surface and activate it chemically
- Formation of acids and metal salts as a result of oil ageing
- Impermissible, aggressive oil additives
- Aggressive products from combustion (sulphur, hydrogen sulphide)
- Contamination of the oil with water or antifreeze
- High operating temperatures accelerate chemical processes such as oil ageing

---

## REMEDY

Corroded bearings must be replaced.

- Always carry out oil changes in accordance with the manufacturer's instructions
- Only use quality oils free from aggressive additives
- Cool engine sufficiently

## 8. DAMAGE TO THRUST WASHERS

Thrust washers enable the absorption of axial forces, which arise when the clutch is actuated, for example. This means one bearing position is always axially supported in the main bearing set.

This is realised through the use of thrust washers or pre-assembled, ready-for-installation collar bearings or flanged bearing halves.

Crack formation from outer edge to outer edge



Large-scale material nick at the outer edge of the thrust washer



---

### POSSIBLE CAUSES

- Axial clearance too low, meaning that the thrust washer is pressed against the interacting sliding parts
- Axial stress too high
- Sustained axial stress
- Shaft flange too rough

---

### REMEDY

- Check the axial clearance of the crankshaft and keep to the specified tolerance range – if necessary use a thrust washer with undersize grade
- Check the axial stress on the thrust washer



**Sliding wear**

Wear marks are visible on the sliding surface of the thrust washer

New state before use

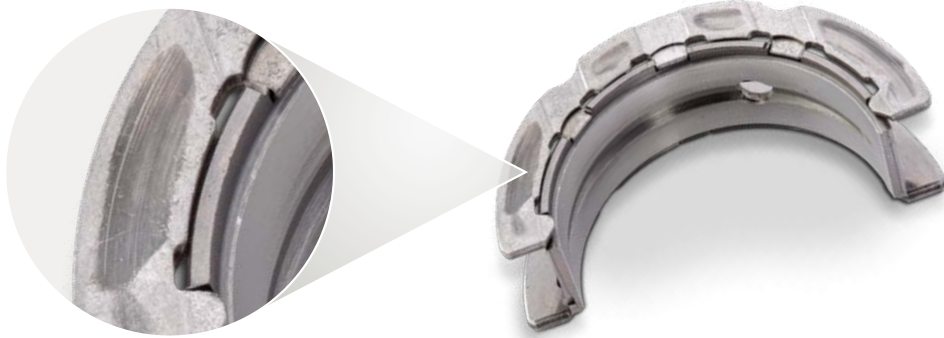

**Advanced sliding wear**

Material displacement and removal; oil groove hardly still there

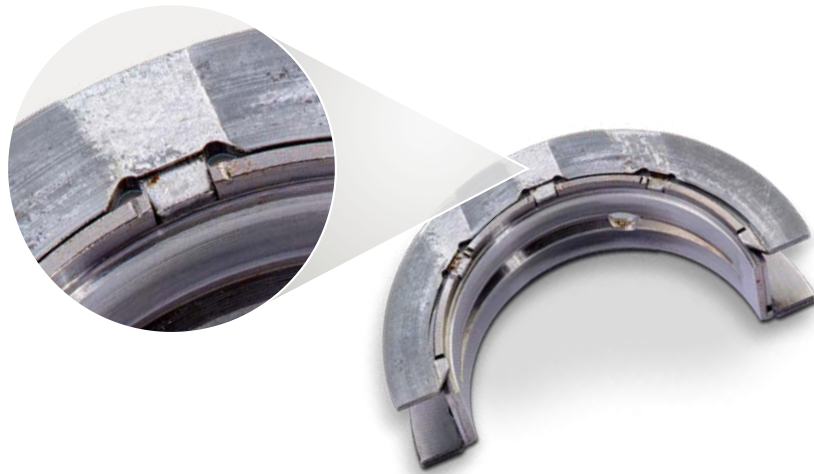

**Seizure**

Areas of torn-out material and pronounced scoring; oil grooves are no longer visible

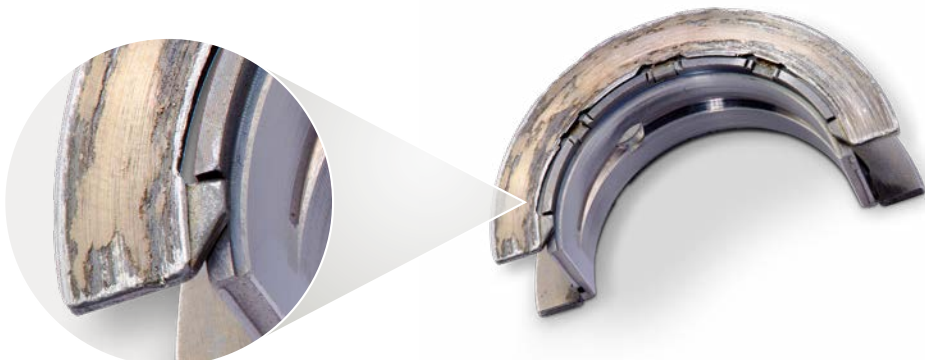

Complete failure



# 9. GLOSSARY

## TECHNICAL NAMES AND NAMES ON THE ENGINE BEARING

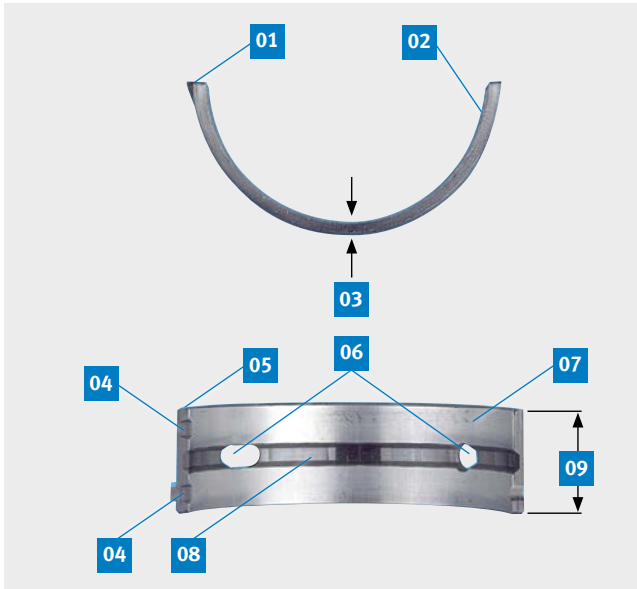

- 01 Parting face
- 02 Sliding surface relief
- 03 Wall thickness
- 04 Left and right locking lugs
- 05 Face relief
- 06 Oil bore
- 07 Sliding surface
- 08 Inner oil groove
- 09 Bearing width

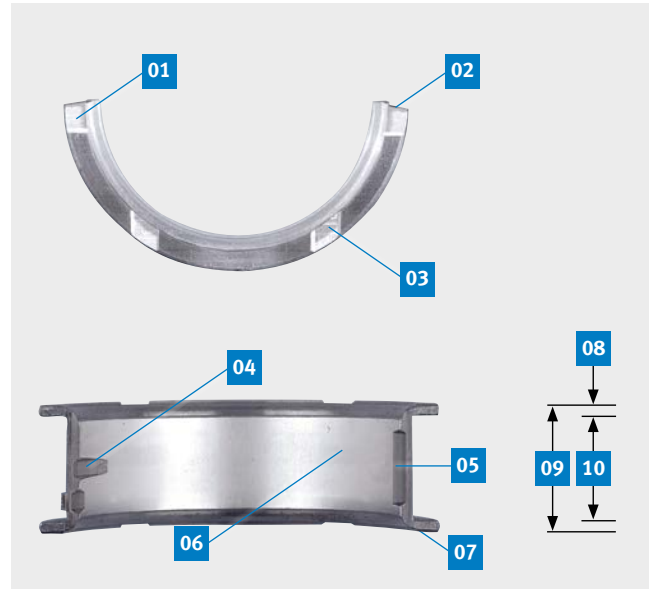

- 01 Face surface relief
- 02 Parting face relief
- 03 Oil groove on face relief
- 04 Crescent groove
- 05 Oil distributing pocket
- 06 Sliding surface
- 07 Face relief
- 08 Flange thickness
- 09 Bearing width
- 10 Flange spacing



- 01 Locking lug
- 02 Oil groove

## EXPLANATION OF TECHNICAL TERMS

### **Abrasive**

Rubbing / grinding

### **Automatic start / stop system**

Start / stop operation for combustion engines is primarily being driven forward due to the required reduction in CO<sub>2</sub> emissions. During start / stop operation, the engine stops when the vehicle comes to a standstill and starts again automatically to drive off. This means the internal engine bearings must have increased resistance to mixed friction. During each start and stop operation, the bearings leave the hydrodynamic operating range and pass through the mixed friction range up to the zero point of sliding speed. Only sliding layers specially optimised for this guarantee sufficient wear resistance under these conditions, which are extremely critical in terms of tribology for the engine bearing.

### **Axial force**

A force which acts in the direction of the axis of a rotating body.

### **Cracked connecting rods**

Cracked connecting rods are initially produced as a single unit, then given break lines (sinter rods) or laser notches (steel connecting rods) and split (cracking) into two parts. Both parts are screwed together when the connecting rods are assembled. Due to the individual breakage geometry, they fit together precisely.

### **Diffusion barrier**

The diffusion barrier is a thin layer, generally made from nickel (Ni) or nickel-chromium (NiCr) which is intended to stop tin diffusion between the sputtered or galvanic sliding layer (upper bearing layer) and the bronze bearing material. Tin diffusion would change the mechanical characteristics of the sliding layer and the bearing metal.

### **Erosion**

The removal of material as a result of the effects of the kinetic energy of solids, liquids or gases acting on the surface.

### **Free spread**

The free spread measure provides the deviation of the external diameter from the ideal circle in the area of the parting face. It represents the elastic recovery after shaping and is measured in the uninstalled state. The resulting preload of the bearing shell facilitates mounting through a good contact with the wall of the bore, preventing the bearing from twisting or falling out.

### **Galvanic**

Electrochemical coating procedure – galvanic layers are applied electrochemically to the fully prepared engine bearings. These enable specific loads of up to 100 MPa. The adaptive processes during run-in are facilitated by the galvanic layers and the particle tolerance of the bearing shells, as well as their emergency running properties, improved.

### **Groove system / oil groove**

Groove systems are necessary to distribute the required lubricant in the bearing, and to thereby enable the creation of a hydrodynamic operating state. They are preferably arranged in the unloaded area of the bearing. Lubricant distribution to other consumers is also guaranteed by groove systems.

### **Initial rubbing marks**

Pre-seizure stage which is caused by severe mixed friction (for example due to lack of lubricating oil). Scoring and mixed friction marks are typical of an initial rubbing mark, as well as displacement of the sliding layer.

### **Liquid friction**

Also called fluid friction. With hydrodynamic engine bearings, a stable lubricating film is not formed at lower speeds; there is mixed friction between the journal and the engine bearing. Only from the transition speed onwards does liquid friction, the desired state, establish itself. Here, a stable lubricating film is formed and the wear of journals and engine bearings is minimised.

### **Locking lugs**

The locking lugs are fixed to the bearing shells in the area of the parting face. They prevent errors during mounting due to the axial positioning.

### **Parting face**

The parting faces of a bearing shell are the free ends of the hollow cylinder section. These areas are created when separating the plate from the strip or during corresponding reworking. During mounting, the upper and lower shells in the housing are tensioned via the parting faces, thus creating the press fit through the protrusion.

### **Polymer coating**

Also polymer bonding. The coating consists of a temperature- and dirt-resistant polyamide resin that contains a high level of friction- and wear-reducing bulking agents. By combining metal and polymer components, the new product is 20% stronger than conventional two-material bearings while also ensuring greater wear-resistance and less friction.

### **Press fit and protrusion**

Bushes and bearing shells are mainly fixed in the housing with press fitting. For bearing shells, the press fit is created by the fact that both half cylinders are produced with a circumferential length greater than 180°. The difference between the actual circumferential length of the bearing shell and the circumferential length in relation to 180° is known as the protrusion. The protrusion of the bearing shell has a direct influence on the press fit.

### **Pressure oil filling**

In order to avoid run-in damage, such as dry running of the engine bearings, the oil system must be filled with pressure oil before the initial engine start and bled.

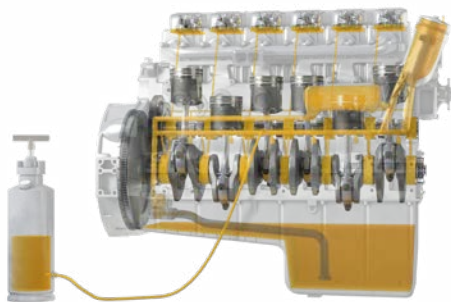

### **Relief**

The area of the bearing shell in which the wall thickness is reduced in the direction of the parting face. This compensates for mounting inaccuracies.

### **Rod-side / cap-side**

In order to be able to mount the connecting rod on the crankshaft, the connecting rod bearing consists of a rod-side and cap-side bearing shell. Once mounted, the connecting rod bolts clamp the bearing shell pair to create a precisely closed bearing. The rod-side bearing shell is subject to a much higher mechanical stress than the cap-side as the gas power from the combustion process is passed to the crankshaft through it. Especially for highly charged diesel engines, specific stresses of 100 MPa and more impact on the engine bearing shell. The cap-side conrod bearing shell has the task of closing the bearing.

### **Roundness**

The roundness of a rotating element in a section (vertically to its actual axis) is the same as the minimum width of the ring between two circles with a common centre. In this section, the centre can be moved freely so that the width of the ring reaches the minimum value. Here, all the points of the element are between these two circles.

### **Sputter**

Enhanced engine performance calls for materials of significantly increased fatigue strength, lower wear rate in mixed friction operation and good corrosion resistance at elevated temperatures, especially for connecting rod bearings. This complex requirements profile is met with the aid of physical vapour deposition (PVD). Under high vacuum, extremely fine particles are beaten out of a dispenser. By means of electromagnetic fields, they are uniformly applied to the part to be coated. These magnetron layers are able to distribute the individual microstructure components extremely finely. This design is based on the well-known three-component bearing. The basic structure is maintained. Here, the galvanic sliding layer is replaced by a sputtered sliding layer. Sputtered bearing shells are primarily used on the thrust side of connecting rod bearings. The opposing shells are conventional two or three-component bearings. The sputtered bearing shell must be correctly positioned on installation to ensure operational safety.

**Transition speed**

Describes the transition point – the area in which the transition from mixed friction to liquid friction takes place due to the higher sliding speed. In hydrodynamic engine bearings – as used in combustion engines – the thin lubricating film only forms at higher sliding speeds. At lower sliding speeds, these engine bearings have to withstand mixed friction with high proportions of dry friction. For this reason, we always strive to keep operation with mixed friction as short as possible.

**Wear mark / wear pattern**

Appearance of the bearing sliding surface caused by contact with the journal during operation.

**Wall thickness**

The bearing clearance is determined by the wall thickness of the engine bearing. As the outer diameter is specified by the press fitting, the bearing clearance relative to the shaft diameter can be adjusted by varying the wall thickness. For reconditioned shafts, there are engine bearings with different oversize grades (larger wall thicknesses).

# KNOW-HOW TRANSFER

## PROFESSIONAL KNOWLEDGE FROM THE EXPERTS

### WORLDWIDE TRAININGS

#### Direct from the manufacturer

Each year, around 4,500 mechanics and engineers benefit from our training courses and seminars, which we hold on-site in locations across the world or in our training centres in Neuenstadt, Dormagen and Tamm (Germany).

### TECHNICAL INFORMATION

#### From practical experience for practical use

Our Product Information and Service Information publications, technical brochures and posters keep you at the forefront of the latest technological developments.

### TECHNICAL VIDEOS

#### Knowledge transfer via video

Our videos provide you with useful information on our products, such as hands-on fitting instructions and system descriptions.



### PRODUCTS IN FOCUS ONLINE

#### Our solutions explained clearly

Interactive elements, animations and video clips provide interesting information about our products in and around the engine.

### ONLINESHOP

#### Your direct access to our products

Order at any time. Quick availability check. Extensive product search by engine, vehicle, dimensions etc.

### NEWS

#### Regular information via e-mail

Subscribe online to our free newsletter now and receive regular information about additions to the product range, technical publications and much more.

### INDIVIDUAL INFORMATION

#### Especially for our customers

We provide extensive information and services relating to our wide range of services: e.g. personalised sales-promoting materials, sales support, technical support and much more.



### TECHNIPEDIA

#### Technical information on all aspects of the engine

We share our know-how with you in our Technipedia. You can get professional knowledge direct from experts here.

### MOTORSERVICE APP

#### Access technical know-how on the move

Here, you will find the latest information and services relating to our products quickly and easily.

### SOCIAL MEDIA

#### Always up to date





**HEADQUARTERS:**

**MS Motorservice International GmbH**

Wilhelm-Maybach-Straße 14–18

74196 Neuenstadt, Germany

[www.ms-motorservice.com](http://www.ms-motorservice.com)

[www.rheinmetall.com](http://www.rheinmetall.com)

© MS Motorservice International GmbH – 50003 859-02 – EN – 05/17 (112022)

