



PUMP EXPERTISE

**SPECIAL ORIGINAL EQUIPMENT (SOE) –
ELECTRICAL WATER PUMPS AND
COOLANT VALVES**



MOTORSERVICE GROUP

QUALITY AND SERVICE FROM A SINGLE SOURCE

The Motorservice Group is the sales organisation for the global aftermarket activities of Rheinmetall. It is a leading supplier of engine components for the independent aftermarket. With the premium brands Kolbenschmidt, Pierburg, TRW Engine Components and the BF brand, Motorservice offers its trade and repair shop customers a wide and comprehensive range of top-quality products.



RHEINMETALL

TECHNOLOGY FOR FUTURE MOBILITY

As a global supplier to the automotive industry, Rheinmetall's expertise in air supply systems, emission control and pumps and in the development, manufacture and spare parts supply of pistons, engine blocks and engine bearings puts it right at the top of the markets. Product development is carried out in close cooperation with well-known automotive manufacturers.



SPECIAL ORIGINAL EQUIPMENT (SOE)

TOP QUALITY – NOT JUST FOR THE AFTERMARKET

A special business segment is SOE, with selected Kolbenschmidt and Pierburg components for a varied range of applications. We deliver high-quality components in low volumes for converted engines, e.g. for generators or components for retrofitters, vehicle tuners and manufacturers of construction machinery and agricultural equipment. Our customers also include manufacturers in non-automotive sectors, from the pharmaceutical and chemical industry, the electrical and electronics industry, and parts suppliers in the field of renewable energy.



Technical expertise

Quick and competent advice and a wide variety of technical data are just some of our goal- and service-orientated services.

- Finding and selecting products
- Initial drafting
- Test phase
- Support right up to start of production
- Management and supply of discontinued series



At the same time, we keep the specific technical and economic factors in mind, and always have our sights on the long-term use of the final application.



KOLBENSCHMIDT



PIERBURG



TRW
EngineComponents

EXPERTISE IN COOLING – PIERBURG

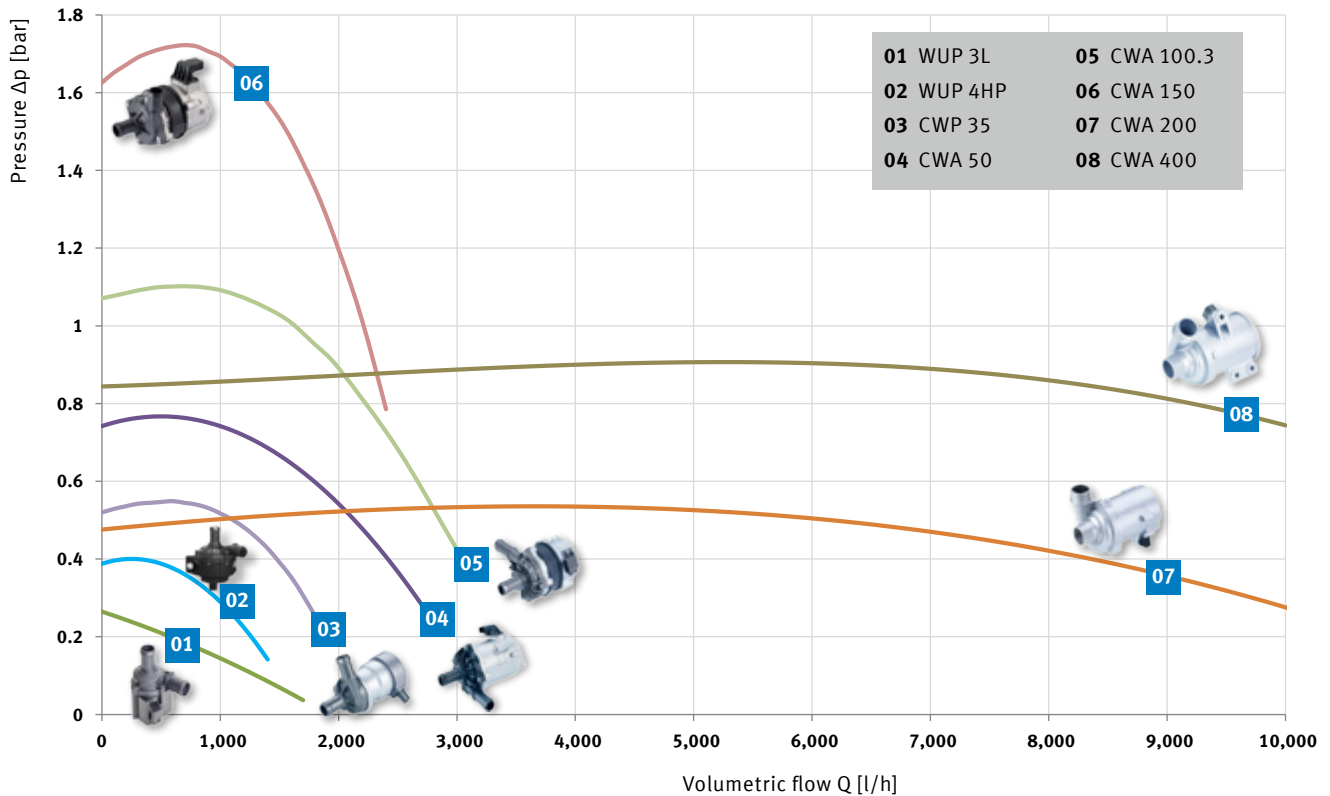

Decades of experience and expertise in the development and manufacture of pumps make Pierburg a globally recognised partner to car manufacturers. This is because electrical water pumps make a significant contribution to emission control on modern engine designs.

Pierburg production sites produce more than 17 million mechanical and electrical water pumps for motor vehicles and utility vehicles every year.

Motorservice offers a wide range of electrical water pumps and water circulating pumps from Pierburg – manufactured in accordance with the highest automotive standards.

The product range

Pierburg has retained a leading market position since 1996 with its small WUP water circulating pumps. They are used, for example, in auxiliary heating systems for quickly heating up the passenger compartment.

Medium-sized CWP electrical coolant pumps are used in the mid-performance range: such as cooling drive motors, power electronics and the batteries of electric and hybrid vehicles.

Electrical CWA coolant pumps offer top performance. Today, they are used for the main cooling of the combustion engine, as well as for cooling the fuel cell stacks of fuel cell drives.

Possible applications for on-demand cooling:

- Combustion motors
- Electric motors
- Batteries
- Turbochargers
- Exhaust gas recirculation
- Vehicle cabs / passenger compartments
- Engine afterrun
- Charge air
- Transmission oil circuit
- Power electronics
- Inverters (rectifiers)
- DC-DC converters
- Power chargers
- Rear-axle cooling
- Solar technology
- Fuel systems
- Air-conditioning applications

WATER CIRCULATING PUMPS – TYPE WUP



WUP generation I



WUP generation III



WUP generation IV

Water circulating pumps are used where cooling or heating functions need to be performed independently of an engine's coolant circuit.

This gives rise to a whole host of application possibilities:

- For heating support, residual heat extraction and pre-heating
- As a cooling application for turbochargers, power electronics and exhaust gas recirculation
- For cooling drives and batteries in electric vehicles
- As a heating circuit pump in photovoltaic applications

The first generation alone was tried and tested millions of times over, proving itself to be a simple and robust coolant pump.

The second to fourth generation then underwent optimisation again in terms of dimensions, weight, control and hydraulic power.

Characteristics:

- Brushless EC motor in 12V or 24 V design
- Radial or axial inlet direction
- Integrated control on a circuit board insulated to ensure water tightness
- Electromagnetic compatibility (EMC) guaranteed
- Not self-priming
- Pump speed can be configured with pulse width modulation signal
- Optional mounting with rubber sleeve (generation I)
- Low power consumption when idling
- Housing with individual attachment points
- Different plug versions (2-pin: Mini Timer, RD)
- Generation II / III: Diagnostic capability as diagnostic trouble codes are output
- Protected against blockages and dry running
- High temperature resistance

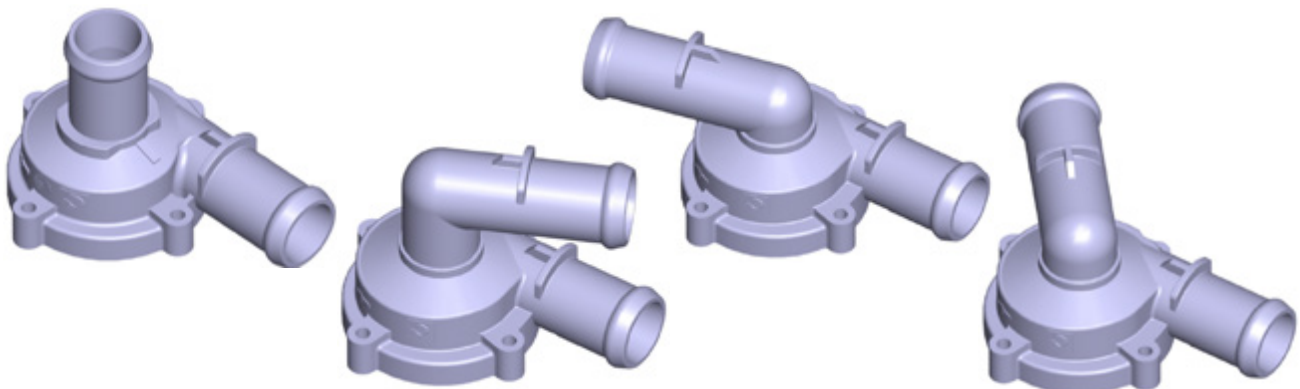

Available pump housing

ELECTRICAL COOLANT PUMPS – TYPE CWA



CWA 400

Electrical CWA coolant pumps make a significant contribution to emission control on modern engine designs.

A delivery rate that is not dependent on the speed of another drive enables demand-based cooling.

This reduces the power requirements whilst also cutting down on frictional loss, fuel consumption and pollutant emissions.

Their characteristics ensure that our coolant pumps are the first choice – and not only when it comes to electric and hybrid applications.

Pierburg has made the electrical water pump ready for series production, and was the world's first series-production supplier for a leading premium vehicle manufacturer.



CWA 150

Characteristics

- Compact radial auxiliary coolant pump
- In the power levels 50, 100, 150, 200 and 400 Watts
- Speed control and extended diagnostics information via PWM or LIN bus
- Efficiency close to 40% at the nominal operating point
- Demand-based cooling
- High flow rate at a low pressure
- Homogeneous heat dissipation
- Optimised for high-temperature applications and more demanding service life requirements
- Improved resistance to influences that impair EMC

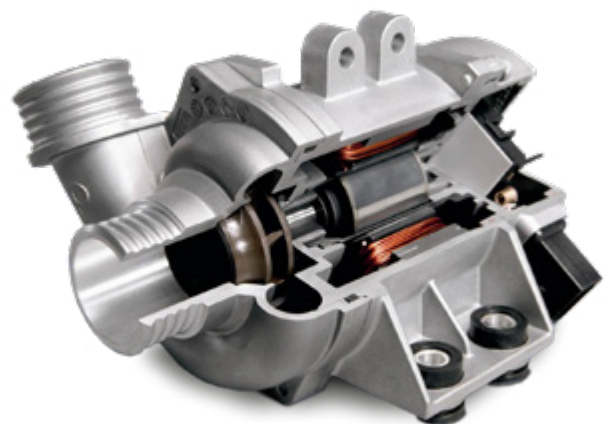

Sectional view of a CWA 200

COOLANT VALVES – TYPE CSV



2/2-way valve



3/2-way valve

These innovative valves play a key role in intelligent heat and energy management in modern vehicle engines. These often have several coolant circuits which can be controlled in a targeted manner using seated on-off valves.

When the engine starts, for example, they switch off the flow of the coolant, thereby bringing the engine up to operating temperature more quickly.

In hybrid and electric vehicles, Pierburg coolant valves can be used for distributing coolant flows, including for temperature control of the batteries and power electronics.

The great versatility of Pierburg coolant valves is a real advantage here. They have pressure compensation, thereby enabling high flow rates with low loss of pressure, despite the small dimensions.

The three-way valve can be used both as a mixing valve as well as a switchover valve, to be able to switch between two circuits for example.

Characteristics:

- Lightweight and compact
- Low pressure loss
- Can be attached to the engine / motor
- Fail-safe function (open / closed when de-energised)
- Robust and durable (>4 million switching cycles)
- 12V version
- Available as 2/2-way isolating valve and 3/2-way switchover / mixing valve



Sectional drawings of the valve variants

PERFECT PRODUCTS AND EXCELLENT SERVICE – THE REST OF THE MOTORSERVICE RANGE



IMA – Industry | Marine | Agriculture

Agricultural machinery, construction machinery, material movement vehicles, industrial plants and machinery for mining and raw material extraction are powered by engines that are mostly exposed to extreme loads. Due to the exacting requirements regarding service life, regular maintenance and the replacement of wear parts is a must. As a renowned spare parts supplier, Motorservice offers spare parts in OEM quality for many engines in these fields.

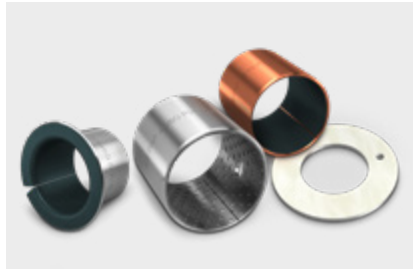

KS PERMAGLIDE®

KS Permaglide® is a registered trademark of KS Gleitlager GmbH and stands for robust, hard-wearing plain bearing materials. A composite, multi-layered system combines the excellent sliding properties of plastic with the high load bearing capacity and thermal conductivity of metal. Permaglide® sliding elements are available in standard design to DIN ISO 3547, or as customised parts based on drawings.



Kolbenschmidt

Pistons for petrol and diesel engines in passenger cars and utility vehicles are produced under the global leading brand of Kolbenschmidt. They also develop and manufacture pistons for 2-stroke and compressor engines, as well as large pistons for stationary engines, marine diesel engines and locomotives.

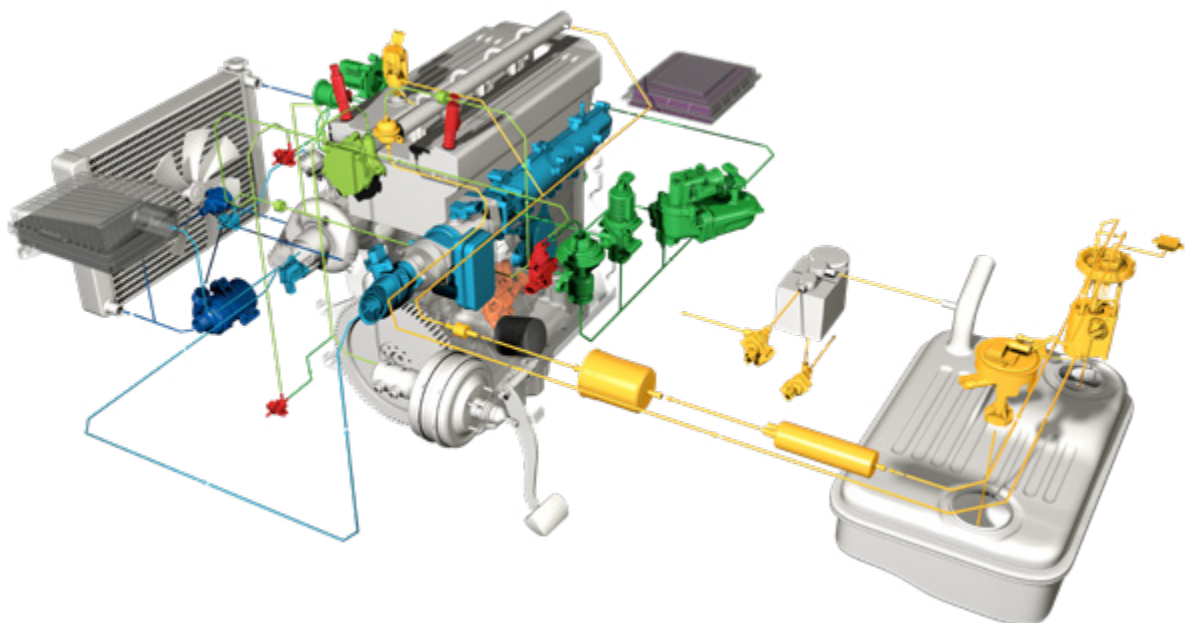

OUR PRODUCTS FOR ALL ASPECTS RELATED TO THE ENGINE

Get in touch with us:

<https://soe.ms-motorservice.com/>

HEADQUARTERS:

MS Motorservice International GmbH

Wilhelm-Maybach-Straße 14–18

74196 Neuenstadt, Germany

www.ms-motorservice.com

www.ms-motorservice.com

© MS Motorservice International GmbH – FL 2037-02 – EN – 08/21 (082021)