



KOLBENSCHMIDT



**TRW**  
EngineComponents

# PRODUCT CATALOG VALVE TRAIN COMPONENTS AND CYLINDER HEADS FOR PASSENGER CARS

TAKING RESPONSIBILITY IN A CHANGING WORLD



RHEINMETALL



# PRODUCT RANGE

## Kolbenschmidt



## Pierburg



## BF





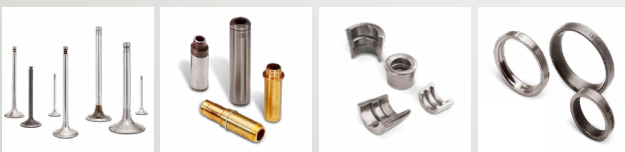



























## TRW Engine Components









TAKING RESPONSIBILITY IN A CHANGING WORLD





	DE	EN	FR	ES	RU	AR																				
	<b>Ventilmaterialien</b>	<b>Valve material</b>	<b>Matériaux des soupapes</b>	<b>Materiales de las válvulas</b>	<b>Материалы клапанов</b>	<b>خامات الصمامات</b>																				
<b>.../S</b>	Bimetall-Ausführung	Bimetal version	Modèle bimétallique	Version bimetalica	Биметаллическое исполнение	تصميم ثنائي المعدن																				
<b>A</b>	Austenitischer CrNiMn-Stahl	Austenitic CrNiMn steel	Acier CrNiMn austénitique	Acero austenítico CrNiMn	Аустенитная сталь CrNiMn	فولاذ CrNiMn أوستنيتي																				
<b>Cr</b>	Ventilschaft verchromt	Valve stem chrome-plated	Tige de soupape chromée	Vástago de la válvula cromado	Хромированный стержень клапана	ساق الصمام مطلي بالكروم																				
<b>I</b>	Nimonic	Nimonic	Nimonic	Nimonic	Нимоник	نيمونيك																				
<b>III</b>	Schaftende gehärtet	Skirt end hardened	Queue de la tige trempée	Extremo del vástago templado	Закаленный конец стержня	نهاية الصمام مصلدة																				
<b>Na</b>	Natriumgefülltes Hohlventil	Sodium-filled hollow valve	Soupape creuse remplie de sodium	Válvula hueca llena de sodio	Полый клапан, заполненный натрием	صمام أجوف مملوء بالصوديوم																				
<b>Nb</b>	Austenitischer CrNi-Stahl	Austenitic CrNi steel	Acier CrNi austénitique	Acero austenítico CrNi	Аустенитная сталь CrNi	فولاذ CrNi أوستنيتي																				
<b>Ni</b>	Nitriertes Ventil	Nitrided valve	Soupape nitrurée	Válvula nitrada	Азотированный клапан	صمام معالج بالنترات																				
<b>RA</b>	Austenitischer CrMnNiNb-Stahl	Austenitic CrMnNiNb steel	Acier CrMnNiNb austénitique	Acero austenítico CrMnNiNb	Аустенитная сталь CrMnNiNb	فولاذ CrMnNiNb أوستنيتي																				
<b>S</b>	CrSi-Stahl	CrSi steel	Acier CrSi	Acero CrSi	Сталь CrSi	فولاذ CrSi																				
<b>VS</b>	Ventilsitz gepanzert	Valve seat armoured	Siège de soupape blindé	Asiento de válvula blindado	Бронированное седло клапана	قاعدة صمام مدرعة																				
<b>Y</b>	Ventilsitz induktionsgehärtet	Valve seat induction-hardened	Siège de soupape trempé par induction	Asiento de válvula templado por inducción	Индуктивно закаленное седло клапана	قاعدة صمام مصلدة بالحث																				
	<b>Ventilschaftend-ausführungen</b>	<b>Valve stem face versions</b>	<b>Modèles de tiges soupape</b>	<b>Versiones de extremo del vástago de la válvula</b>	<b>Исполнения концов стержня клапана</b>	<b>تصميمات قاعدة الصمام</b>																				
	1	2	3	4	5	6	7	8	9	10	11	12	13	14	15	16	17	18	19	20	21	22	23	24	25	26
																										
	<b>Ventilkegelstücke</b>	<b>Valve cotters</b>	<b>Demi-cônes</b>	<b>Chavetas cónicas de válvula</b>	<b>Сухари клапанов</b>	<b>قطع مخروطية للصمامات</b>																				
<b>KK</b>	Klemmende Verbindung, Rillenkegelstück	Clamping connection, groove cotter	Liaison serrante, demi-cône rainuré	Conexión con apriete, chaveta cónica con ranura	Клеммное соединение, сухарь с канавкой	وصلة زلق، قطعة مخروطية مضلعة																				
<b>LK</b>	Klemmende Verbindung, Rillenkegelstück	Clamping connection, groove cotter	Liaison serrante, demi-cône rainuré	Conexión con apriete, chaveta cónica con ranura	Клеммное соединение, сухарь с канавкой	وصلة زلق، قطعة مخروطية مضلعة																				
<b>RK</b>	Klemmende Verbindung, Rillenkegelstück	Clamping connection, groove cotter	Liaison serrante, demi-cône rainuré	Conexión con apriete, chaveta cónica con ranura	Клеммное соединение, сухарь с канавкой	وصلة زلق، قطعة مخروطية مضلعة																				
<b>MK</b>	Nicht klemmende Verbindung, Mehrillenkegelstück	Non-clamping connection, multi-groove cotter	Liaison non serrante, demi-cône à rainures multiples	Conexión sin apriete, chaveta cónica de varias ranuras	Неклеммное соединение, сухарь с канавками	وصلة بدون زلق، قطعة مخروطية بتضليعات متعددة																				
	<b>Ventilführungs-materialien</b>	<b>Valve guide material</b>	<b>Matériaux des guides de soupape</b>	<b>Materiales de las guías de válvulas</b>	<b>Материалы направляющей клапана</b>	<b>خامات دليل الصمامات</b>																				
<b>B1</b>	CuZnAl-Legierung	CuZnAl alloy	Alliage CuZnAl	Aleación CuZnAl	Сплав CuZnAl	سبيكة CuZnAl																				
<b>B2</b>	CuNiSi-Legierung	CuNiSi alloy	Alliage CuNiSi	Aleación CuNiSi	Сплав CuNiSi	سبيكة CuNiSi																				
<b>B3</b>	Metalloïdhaltige Sonderlegierung	Metalloïd-containing special alloy	Alliage spécial contenant des metalloïdes	Aleación especial conteniendo metaloides	Специальный сплав, содержащий металлоиды	سبيكة خاصة تحتوي على أشباه فلزات																				
<b>B4</b>	Wie B3, jedoch für Auslaßführungen	Like B3, but for exhaust valve guides	Comme B3, mais pour guides d'échappement	Como B3, pero para guías de escape	Как B3, только для выпускных направляющих	مثل B3، ولكن لمنافذ العادم																				
<b>CC</b>	Sprengring	Retainer	Jonc	Anillo de retención	Пружинное стопорное кольцо	حلقة نابضية																				
<b>G1</b>	Grauguß mit perlitischem Gefüge	Grey cast iron with pearlitic structure	Fonte grise à structure perlitique	Fundición gris con estructura perlítica	Серый чугун с перлитной структурой	حديد صب رمادي ببنية لؤلؤية																				
<b>G2</b>	Grauguß mit hohem Phosphorgehalt	Grey cast iron with high proportion of phosphorus	Fonte grise à haute teneur en phosphore	Fundición gris con alto contenido de fósforo	Серый чугун с высоким содержанием фосфора	حديد صب رمادي بمحتوى عالٍ من الفوسفات																				
<b>G3</b>	Wie G2 mit einem zusätzl. Cr-Anteil	Like G2 with an additional proportion of Cr	Comme G2 avec une teneur en Cr supplémentaire	Como G2 con una proporción adicional de Cr	Как G2 с дополн. содержанием хрома	مثل G2 مع نسبة Cr إضافية																				

	DE	EN	FR	ES	RU	AR
	<b>Material Ventilsitzringe</b>	<b>Material valve seat inserts</b>	<b>Matériau des bagues de siège de soupape</b>	<b>Material Insertos para asientos de válvulas</b>	<b>Материал колец седла клапана</b>	<b>خامة حلقات قواعد الصمامات</b>
<b>G1</b>	Hohe Temperaturbeständigkeit	High temperature resistance	Haute résistance à la température	Resistente a altas temperaturas	Высокая термостойкость	تحمل درجة الحرارة العالية
<b>G2</b>	Verschleißfest	Wear resistant	Résistance à l'usure	Resistente al desgaste	Износостойкость	مقاومة للتآكل
<b>HM semi finished</b>	Gute Zerspanbarkeit	Good machinability	Bonne usinabilité	Buena mecanizabilidad	Хорошая обрабатываемость резанием	قابلية جيدة للبري
<b>HT semi finished</b>	Hohe Temperaturbeständigkeit	High temperature resistance	Haute résistance à la température	Resistente a altas temperaturas	Высокая термостойкость	تحمل درجة الحرارة العالية
<b>HT+ semi finished</b>	sehr hohe Temperatur- und Verschleißfestigkeit	Very high temperature and wear resistance	Très haute résistance à la température et à l'usure	Altamente resistente a temperaturas extremas y al desgaste	Очень высокая термостойкость и износостойкость	تحمل درجة الحرارة العالية للغاية والتآكل
<b>HRC</b>	Hohe Korrosionsbeständigkeit Siehe Maßlisten Ventilsitzringe	High corrosion resistance See lists of dimensions valve seat inserts	Grande résistance anticorrosion Voir listes des cotes des bagues de siège de soupape	Elevada resistencia a la corrosión Véanse listas de dimensiones de insertos para asientos de válvulas	Высокая коррозионная стойкость См. перечни размеров колец седла клапана	مقاومة عالية للصدأ انظر قوائم ابعاد حلقات قواعد الصمامات
	<b>Nockenwellen</b>	<b>Camshafts</b>	<b>Arbres à cames</b>	<b>Árboles de levas</b>	<b>Распределительные валы</b>	<b>أعمدة الكامات</b>
	<b>Zylinderkopfkomponenten</b>	<b>Cylinder head components</b>	<b>Composants de culasse</b>	<b>Componentes de la culata del cilindro</b>	<b>Компоненты головки блока цилиндров</b>	<b>مكونات رأس الأسطوانة</b>
<b>CAM</b>	Nockenwelle	Camshaft	Arbre à cames	Árbol de levas	Распределительный вал	عمود الكامات
<b>CB</b>	Zylinderkopfschrauben	Cylinder head bolts	Vis de culasse	Tornillos de culata del cilindro	Болты крепления головки блока цилиндров	براغي رأس الأسطوانة
<b>EVB</b>	Konstantdrosselventil	Constant throttle valve	Papillon constant	Válvula de estrangulamiento constante	Клапан с постоянным дросселем	صمام خائق مستمر
<b>G</b>	Ventilführung	Valve guide	Guide de soupape	Guía de válvula	Направляющая клапана	مجرى الصمام
<b>PC</b>	Vorkammer	Prechamber	Chambre de précombustion	Antecámara	Предкамера	الحجرة الأولية
<b>S</b>	Ventilsitzring	Valve seat insert	Bague de siège de soupape	Inserto para asiento de válvula	Кольцо седла клапана	حلقة قاعدة الصمام
<b>SB</b>	Stehbolzen	Stud bolt	Boulon fileté	Perno roscado	Распорный болт	خابور رأسي
<b>V</b>	Ventile	Valves	Soupapes	Válvulas	Клапаны	صمامات
	<b>Stößel</b>	<b>Tappet</b>	<b>Poussoirs</b>	<b>Taqués</b>	<b>Толкатели</b>	<b>غشازات</b>
	<b>Kipp- / Schleppebel</b>	<b>Rocker arm / finger type rocker arm</b>	<b>Culbuteurs</b>	<b>Balancín y palanca de arrastre</b>	<b>Коромысла / балансиры</b>	<b>ذراع قلب/جرار</b>
	<b>Motorart</b>	<b>Engine type</b>	<b>Type de moteur</b>	<b>Tipo de motor</b>	<b>Тип двигателя</b>	<b>نوع المحرك</b>
<b>A</b>	Aufgeladen	Supercharged	Suralimenté	Sobrealimentado	С наддувом	مشحون
<b>K</b>	Kompressor	Compressor	Compresseur	Compresor	Компрессор	كمبريسور
<b>LA</b>	Aufgeladen mit Ladeluftkühlung	Supercharged with charge air cooling	Suralimenté avec refroidissement d'air de suralimentation	Sobrealimentado con enfriamiento del aire de admisión	С наддувом и охлаждением наддувочного воздуха	مشحون مع تبريد لهواء الشحن
	<b>Kraftstoffart</b>	<b>Type of fuel</b>	<b>Type de carburant</b>	<b>Tipo de combustible</b>	<b>Вид топлива</b>	<b>نوع الوقود</b>
<b>AB</b>	FuelFlex	FuelFlex	FuelFlex	FuelFlex	FuelFlex	FuelFlex
<b>AL</b>	Alkohol	Alcohol	Alcool	Alcohol	Спирт	كحول
<b>B</b>	Benzin	Petrol	Essence	Gasolina	Бензин	بنزين
<b>D</b>	Diesel	Diesel	Diesel	Diésel	Дизель	ديزل
<b>G</b>	Gas	Gas	Gaz	Gas	Газ	غاز
<b>GF</b>	Flüssiggas (Propan / Butan)	Liquid gas (propane / butane)	Gaz liquide (propane / butane)	Gas licuado (propano / butano)	Сжиженный газ (пропан / бутан)	غاز مسال (بروبان/بيوتان)





# NO FAKES!

## LABEL AND SECURITY SEAL

### 1 SECURITY SEAL

#### ORIGINAL CLOSURE



#### DAMAGED CLOSURE



**ATTENTION**  
Label and Security Seal must always be undamaged.

### 2 SECURITY CODE



**TESA® HOLOSPOT SECURITYCODE (FOUR-DIGIT) WITH 2D MATRIX CODE**

On the label the logo and Security-Code shine in rainbow colours when under direct light. The four digits match the last four digits of the complete 2D matrix code.

### 3 ONLINE CHECK



(01)04052938000016(21)J2VPF2P400440D



**MOTORSERVICE APP**  
YOUR MOBILE FAKE CHECK

[www.ms-motorservice.com/app](http://www.ms-motorservice.com/app)

VENTILE | VENTILKEGELSTÜCKE | VENTILFÜHRUNGEN | VENTILSITZRINGE |  
NOCKENWELLEN | NOCKENWELLENZUBEHÖR | ZYLINDERKÖPFE

VALVES | VALVE COTTERS | VALVE GUIDES | VALVE SEAT INSERTS |  
CAMSHAFTS | CAMSHAFT ACCESSORIES | CYLINDER HEADS

SOUPAPES | DEMI-CÔNES | GUIDES DE SOUPAPE | BAGUES DE SIÈGE DE SOUPAPE |  
ARBRES À CAMES | ACCESSOIRES POUR ARBRES À CAMES | CULASSES

VÁLVULAS | CHAVETAS CÓNICAS DE VÁLVULA | GUÍAS DE VÁLVULA |  
INSERTOS PARA ASIENTOS DE VÁLVULAS | ÁRBOLES DE LEVAS |  
ACCESORIOS DE ÁRBOLES DE LEVAS | CULATAS DEL CILINDRO

КЛАПАНЫ | СУХАРИ КЛАПАНОВ | НАПРАВЛЯЮЩИЕ КЛАПАНОВ |  
КОЛЬЦА СЕДЛА КЛАПАНА | РАСПРЕДЕЛИТЕЛЬНЫЕ ВАЛЫ | ПРИНАДЛЕЖНОСТИ  
К РАСПРЕДЕЛИТЕЛЬНОМУ ВАЛУ | ГОЛОВКИ БЛОКОВ ЦИЛИНДРОВ

الصمامات | قطع مخروط الصمام | مجاري الصمامات | حلقات قواعد الصمامات  
أعمدة الكامات | ملحقات عمود الكامات | رؤوس الأسطوانات

## Index

Page

<b>DE</b>	Grundlagen	2
	Hinweise zur Benutzung des Katalogs	10
<b>EN</b>	Basic information	20
	Instructions for using the catalogue	28
<b>FR</b>	Généralités	38
	Précisions sur l'utilisation du catalogue	46
<b>ES</b>	Fundamentos	56
	Indicaciones para la utilización del catálogo	64
<b>RU</b>	Основы	74
	Примечания по пользованию каталогом	82
<b>AR</b>	نقاط أساسية	107
	إرشادات استخدام الكاتالوج	99

### Disclaimer

Namen, Beschreibungen, Nummern von Motoren, Fahrzeugen, Produkten, Herstellern etc. sind nur zu Vergleichszwecken aufgeführt. Die im Katalog enthaltenen Teile sind Ersatzteile für die aufgeführten Applikationen.

Names, descriptions and numbers of engines, vehicles, products, manufacturers, etc. are mentioned solely for the purpose of comparison. The parts contained in the catalogue are spare parts for the applications listed.

Les noms, les descriptions, les numéros de moteurs, les véhicules, les produits, les constructeurs, etc., ne sont donnés qu'à des fins de comparaison. Les articles mentionnés dans le catalogue sont des pièces de rechange destinées aux applications stipulées.

Los nombres, las designaciones y los números de motores, vehículos, productos o de fabricantes, etc., se indican sólo a modo de comparación. Las piezas incluidas en el catálogo son repuestos para las aplicaciones indicadas.

Названия, описания и номера двигателей, транспортных средств, продуктов, изготовителей и т. п. приводятся только для сравнения. Содержащиеся в каталоге части представляют собой запасные части для приведенных продуктов.

أسماء وشروح وأرقام المحركات والسيارات والمنتجات والشركات المنتجة وغيرها منكرة فقط بهدف المقارنة. والأجزاء المذكورة في الكاتالوج عبارة عن قطع غير للتطبيقات المذكورة.



## WICHTIGE HINWEISE

Alle Angaben in diesem Katalog sind unverbindlich. Für deren Richtigkeit und Vollständigkeit können wir keine Haftung übernehmen. Informationen über eventuelle Fehler im Katalog sind uns stets willkommen und werden in den zukünftigen Ausgaben korrigiert.

Namen, Beschreibungen und Nummernangaben von Fahrzeugen oder Herstellern u. ä. sind ebenso wie die Original-Teilnummern der Fahrzeug- und Motorenhersteller nur zu Vergleichszwecken aufgeführt. Entsprechende Angaben sind keine Herkunftsbezeichnungen und dürfen gegenüber Dritten nicht verwendet werden. Bitte beachten Sie zudem, dass Änderungen der Ausrüstung durch die Fahrzeug- oder Motorenhersteller bzw. Änderungen der Bezeichnungen nicht ausgeschlossen werden können. Für die Anwendung der Vergleichslisten können wir daher keine Haftung übernehmen.

Wir behalten uns ausdrücklich vor, die Produktspezifikationen, die Werkstoffe, das Aussehen und den Lieferumfang unserer Produkte jederzeit zu ändern. Die Abbildungen im Katalog sind daher unverbindlich.

Vor dem Einbau ist stets zu prüfen, ob das erworbene Produkt für den beabsichtigten Verwendungszweck geeignet ist. Eine Aussage über eine bestimmte Beschaffenheit oder eine Eignung für einen bestimmten Einsatzzweck kann aus unseren Angaben nicht abgeleitet werden. Insbesondere gilt es zu beachten, dass die im Katalog angebotenen Produkte nicht für den Einsatz in Luft- und Raumfahrzeugen bestimmt sind. Bei der Verwendung in Off-Highway Motoren (z. B. Marine-, Stationär- oder Bahn-Motoren) ist darauf zu achten, dass bei gleicher Motorbezeichnung unterschiedliche Motorenteile (z. B. Kolben) zum Einsatz kommen können. Ggf. ist vor dem Einbau der Produkte daher der fachkundige Rat des Herstellers oder dessen autorisierter Vertragswerkstatt einzuholen. Wir weisen zudem darauf hin, dass der Einbau stets durch unterwiesenes Fachpersonal zu erfolgen hat. Abbildungen, Schemazeichnungen und andere Angaben dienen der Erläuterung und Darstellung und können nicht als Grundlage für den Einbau verwendet werden.

Jegliche Vervielfältigung, Nachahmung, Verbreitung oder öffentliche Wiedergabe dieses Kataloges, auch auszugsweise, ist nur mit unserer vorherigen schriftlichen Zustimmung und einer entsprechenden Quellenangabe gestattet. Mit Erscheinen dieses Kataloges verlieren alle früheren Ausgaben ihre Gültigkeit.

## ZERTIFIZIERUNGEN

MS Motorservice International GmbH verfügt über ein nach ISO 9001 zertifiziertes Qualitätsmanagementsystem und ein nach ISO 14001 zertifiziertes Umweltmanagementsystem.





DIE INHALTE DES KATALOGS SIND AUCH IN UNSEREM ONLINE KATALOG, IN UNSERER APP SOWIE AUF TECALLIANCE ENTHALTEN.

**Weitere Informationen:**  
**catalog.ms-motorservice.com**  
**motorservice.app**

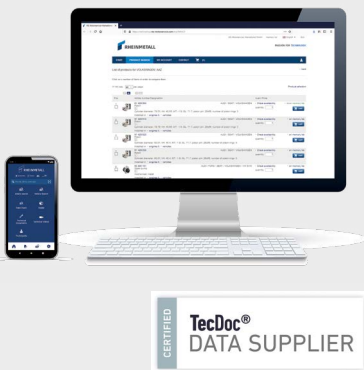

INHALT	SEITE
Wichtige Hinweise	2
Qualitätsmanagement	2
Know-how Transfer – Fachwissen vom Experten	4
1. Ventiltrieb-Komponenten und Zylinderköpfe	7
<b>2. HINWEISE ZUR BENUTZUNG DES KATALOGS</b>	<b>10</b>
3. Ventilegelstücke – Ausführungen und Abmessungen	16
4. Anwendungsempfehlungen und Einbauhinweise	18
5. Maßlisten Ventilsitzringe	109
5.1 Sortiert nach Außendurchmesser D (mm)	110
5.2 Sortiert nach Außendurchmesser D (inch)	117
6. Programmergänzung	123
7. Herstellerverzeichnis	139
<b>8. PRODUKTPROGRAMM</b>	<b>141</b>
9. Kolbenschmidt/ BF / TRW Engine Components-Nr. – Anwendungen	1419
10. Referenzliste	1457
11. Vorgehensweise bei Reklamation / Reklamationsformular	

## MOTORSERVICE GRUPPE

### QUALITÄT UND SERVICE AUS EINER HAND

Die Motorservice Gruppe ist die Vertriebsorganisation für die weltweiten Aftermarket-Aktivitäten von Rheinmetall. Sie ist ein führender Anbieter von Motorkomponenten für den freien Ersatzteilmarkt. Mit den Premiummarken Kolbenschmidt, Pierburg, TRW Engine Components sowie den Marken BF und turbo by Intec bietet Motorservice seinen Kunden aus Handel und Werkstatt ein breites und tiefes Sortiment in Spitzenqualität.

## RHEINMETALL

### TECHNOLOGIEN FÜR DIE MOBILITÄT DER ZUKUNFT

Als weltweiter Automobilzulieferer nimmt Rheinmetall mit seiner Kompetenz in den Bereichen Luftversorgung, Schadstoffreduzierung und Pumpen sowie bei der Entwicklung, Fertigung und Ersatzteillieferung von Kolben, Motorblöcken und Gleitlagern Spitzenpositionen auf den jeweiligen Märkten ein. Die Produktentwicklung erfolgt in enger Kooperation mit renommierten Automobilherstellern.



# KNOW-HOW TRANSFER FACHWISSEN VOM EXPERTEN

## WELTWEITE SCHULUNGEN

### Direkt vom Hersteller

Jährlich profitieren rund 4.500 Mechaniker und Techniker von unseren Schulungen und Seminaren, die wir weltweit vor Ort oder auch in unseren Schulungszentren in Neuenstadt, Dormagen und Tamm (Deutschland) durchführen.

## TECHNISCHE INFORMATIONEN

### Aus der Praxis für die Praxis

Mit unseren Produkt Informationen, Service Informationen, technischen Broschüren und Postern sind Sie immer auf dem neuesten Stand der Technik.

## TECHNISCHE VIDEOS

### Wissensvermittlung per Video

In unseren Videos finden Sie praxisbezogene Einbauhinweise und Systemerklärungen rund um unsere Produkte.



## PRODUKTE IM FOKUS ONLINE

### Unsere Lösungen anschaulich erklärt

Erfahren Sie durch interaktive Elemente, Animationen und Videoclips Wissenswertes über unsere Produkte im und um den Motor.

## ONLINESHOP

### Ihr direkter Zugang zu unseren Produkten

Bestellen rund um die Uhr. Schnelles Prüfen der Verfügbarkeit. Umfangreiche Produktsuche über Motor, Fahrzeug, Abmessungen usw..

## NEWS

### Regelmäßige Informationen per E-Mail

Melden Sie sich jetzt online zu unserem kostenlosen Newsletter an und Sie erhalten regelmäßige Informationen über Produktneuaufnahmen, technische Publikationen und vieles mehr.

## INDIVIDUELLE INFORMATIONEN

### Speziell für unsere Kunden

Von uns erhalten Sie umfangreiche Informationen und Services zu unserem breiten Leistungsspektrum: wie z. B. personalisierte Verkaufsförderungsmaterialien, Verkaufsunterstützungen, technischen Support und vieles mehr.



## TECHNIPEDIA

### Technische Informationen rund um den Motor

In unserer Technipedia teilen wir unser Know-how mit Ihnen. Hier finden Sie Fachwissen direkt vom Experten.

## MOTORSERVICE APP

### Mobiler Zugang zu technischem Know-how

Hier erhalten Sie schnell und einfach die aktuellsten Informationen und Services rund um unsere Produkte.

## SOCIAL MEDIA

### Immer aktuell

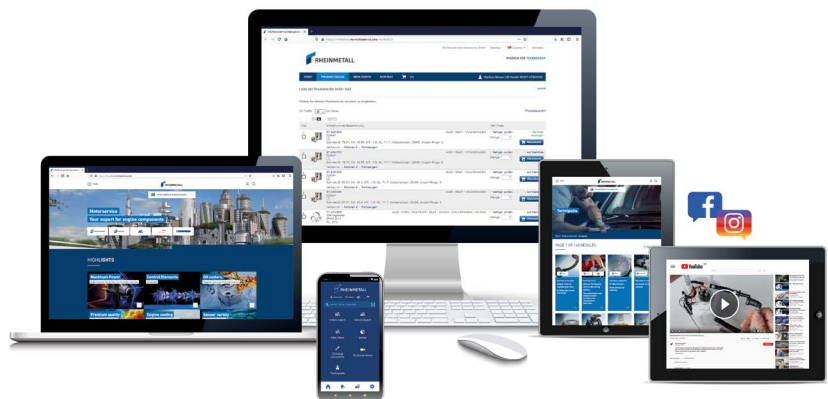

[www.ms-motorservice.com](http://www.ms-motorservice.com)







# 1. VENTILTRIEB-KOMPONENTEN UND ZYLINDERKÖPFE

## VENTILE

### Qualität und Sicherheit für viele Kilometer

Die Ventile erfahren während einer Betriebszeit von 200.000 km rund 200 Millionen Lastwechsel. Aus diesem Grund werden Ventile von TRW Engine Components auf Basis moderner Berechnungsmethoden (FEA) ausgelegt und vor der Serienfreigabe umfangreichen Prüfungen unterzogen.



## VENTILFÜHRUNGEN

### Führung auf hohem Niveau

Unter extremen Bedingungen zentriert die Ventilfehrung das Ventil auf den Ventilsitzring und leitet hierbei auch noch einen Teil der Wärme zum Zylinderkopf ab. Das Material und dessen Eigenschaften sind ein entscheidender Faktor bei diesen extremen Belastungen – gehen Sie auf Nummer sicher und setzen Sie auf die Produktqualität von TRW Engine Components.



## VENTILSITZRINGE

### Für jeden Einsatz das passende Material

Die zunehmend hohe thermische und mechanische Beanspruchung des Sitzringes in modernen Motoren kann mit Werkstoffen aus herkömmlichen Gießverfahren kaum noch bewerkstelligt werden. Aus diesem Grund bietet Motorservice neben den Gussitzringen auch gesinterte Ventilsitzringe aus drei verschiedenen Werkstoffkombinationen an.



## NOCKENWELLEN

### Verschleißfeste Nocken für ein langes, leistungsstarkes Motorenleben

Um die hohen Biege- und Torsionsbeanspruchungen über einen langen Zeitraum zu bewältigen, weisen die Nockenwellen aus dem Motorservice Lieferprogramm hohe Festigkeiten auf. Je nach Einsatzzweck werden Nockenwellen gegossen oder geschmiedet.









## HYDROSTÖSSEL

### Wartungsfreier, automatischer Ausgleich

Durch die Konstruktion der Hydrostössel entfällt das notwendige Prüfen und Nachstellen des Spiels und senkt entsprechend umfangreiche Wartungskosten. Hydrostössel arbeiten fast spielfrei – das mindert den betriebsbedingten Verschleiß und wirkt sich zudem günstig auf die Laufruhe und den Wirkungsgrad der Motoren aus.



## STEUERUNGSELEMENTE

### Solide Verbindung

Eine zuverlässige und exakte Kraftübertragung zwischen Nockenwelle und Zylinderkopf kann nur mit hochwertigen Steuerelementen realisiert werden. Steuerelemente von Motorservice garantieren Exaktheit und Langlebigkeit der kompletten Ventilsteuerung.



## ZYLINDERKÖPFE

### Bedarfsgerecht für Sie komplettiert

Motorservice verfügt über ein ausgewähltes Produktportfolio an Zylinderköpfen für Pkw und Nkw. Bedarfsgerecht und reparaturfreundlich sind die Zylinderköpfe auch mit vormontierten Ventilen und Ventildedern erhältlich.



Technische Informationen zu Produkten, Einbau und Einlauf finden Sie unter:  
[www.ms-motorservice.com](http://www.ms-motorservice.com)

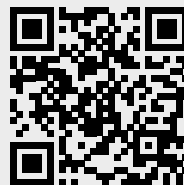

## 2. HINWEISE ZUR BENUTZUNG DES KATALOGS

### MOTORENINDEX

Am Anfang des jeweiligen Herstellers befindet sich eine ausführliche Suchhilfe. Die Motorenbezeichnungen sind aufsteigend alphanumerisch sortiert.

		<b>INDEX</b>								<b>DEUTZ</b>	
		Cyl.		mm	cm <sup>3</sup>	Comp. Ratio	ε	kW	PS	Pos	
A 6 M 816		D (AN) 6		142 x 160	15204	2	16:1	145-172	197-234	45	
A 6 M 816 R		D (LA) 6		142 x 160	15204	2	16:1			45	
A 6 M 816 U		D (LA) 6		142 x 160	15204	2	16:1			45	
A 6 M 816 W		D (LA) 6		142 x 160	15204	2	16:1			45	

**Motor** **Positionsnummer**

### FAHRZEUGINDEX

Am Anfang des jeweiligen Herstellers befindet sich eine ausführliche Suchhilfe. Die Fahrzeuge sind aufsteigend alphanumerisch nach der Fahrzeugklasse sortiert.

		<b>INDEX</b>				<b>AUDI</b>			
			Pos				Pos		
A1 (8X)				A4 1.8i Turbo 20V	01.1999 → 06.2000	ANB	B 23		
1.4 TFSI	05.2010 →	CAXA	B 3	A4 1.8i Turbo 20V	06.2000 → 09.2001	AWT	B 27		
2.0 TDI	09.2011 →	CFHB	D 33	A4 1.9 TDI	01.1995 → 07.1996	1Z	D 11		
A2 (8Z)				A4 1.9 TDI	03.1996 → 07.1999	AFN	D 11		

**Fahrzeug / Modellreihe** **Positionsnummer**



MOTORENZEILE

<b>Positionsnummer</b> (fortlaufende Nummerierung innerhalb eines Herstellers)		<b>Baujahr von → bis</b>		<b>Kolbenfamilien für die aufgeführten Motoren.</b> Details zur Verwendung siehe Kolbenkatalog.			<b>Verdichtungsverhältnis</b>	
<b>Zylinder-Nenn-Ø</b>		<b>Ladeart*</b>					<b>Hub</b>	
<b>24</b>	 <b>115</b>	<b>Cyl. 6</b>		93 152 6... 91 151 6...				
<b>D 5TC EURO 1</b>	<b>03.1988 -&gt; 04.1994</b>	<b>D [AN]</b>	<b>6</b>	<b>7800 cm3</b>	<b>2V</b>	<b>178 KW (242 PS)</b>	<b>16:1</b>	<b>125 mm</b> (1)
(1) Conrod length = 220 mm	mot. -> 456789							
<b>PL</b>	St/A	50,000	53,708	29,00	1,822	STD	4	<b>77 099 608</b>
<b>Bemerkungen</b>	<b>Motornummer / Seriennummer</b>		<b>Zylinderanzahl</b>		<b>Hubraum</b>		<b>Hinweis auf Bemerkungen</b>	
<b>Motorbezeichnung mit Kat-Ausführung / Schadstoffart</b>		<b>Kraftstoffart*</b>		<b>Ventilanzahl</b>		<b>Leistung von → bis</b>		

\* siehe Abkürzungsverzeichnis

**PRODUKTDATEN**

Die Katalogseiten bestehen aus den nachstehend aufgeführten Informationsblöcken:

Ventilkegelstücke		Herstellerfeld	
Positionsnummer	Piktogrammzeile	Motorenzeile	Ventile
		<div style="border: 1px solid black; padding: 5px; display: inline-block;">Hersteller</div>	
<div style="border: 1px solid black; padding: 2px;">24</div>		<div style="border: 1px solid black; padding: 2px;">115 Cyl. 6</div>	
<b>D 5TC EURO 1</b>		<b>03.1988 -&gt; 04.1994</b>	
<small>[1] Conrod length = 220 mm 94 347 6.</small>		<small>mot. -&gt; 456789</small>	
<b>D [AN]</b>		<b>6 7800 cm3 2V 178 kW (242 PS) 16:1 125 mm</b> <small>[1]</small>	
	<b>IN [2]</b> 39 x 7,9 x 114,3 M+0,8	I - C - Na - 44,5° - Y - 22 - V	<b>105-35470</b>
	<b>EX [2]</b> 33,4 x 7,9 x 114,3 S+0,15	RA - C - - 44,5° - Y - 18 - III	<b>105-03364</b>
	<b>[50]</b> 8		<b>12345678</b> <b>KK-8</b>
	<b>IN/EX [4]</b> 12,06/15,2x7,98 x 36,5	B1	<b>056 103 419A</b> <b>81-3310</b>
	<b>IN/EX [4]</b> 45,08 / 37 x 8,3	T 45°	<b>352 053 16 31</b> <b>352 053 22 31</b> <b>50 004 885</b>
	491	AS/ES/L/R	<b>028 109 101E</b> <b>50 006 204</b>
	<b>TAP [8]</b> H 21,4 x 68 x 28		<b>6 40 051</b> <b>6 40 059</b> <b>90295215</b> <b>50 006 457</b>
	<b>[4]</b>		<b>059 109 444</b> <b>50 006 410</b>
	- - G - S - PC - SB -  CAM - V - G - S - PC - SB - CB ready to install mot. 770.001-> <small>[1] Hydrosößel/Vorkammerbohrung Ø 32 mm hydraulic lifter/prechamber bore dia. 32 mm poussoirs hydrauliques/alésages pur la pré-chambre dia. 32 mm empuñadores hidráulicos/précamaras perforación dia. 32 mm</small>	<div style="border: 1px solid black; padding: 2px; display: inline-block;">                         9 5 3 1 7 11                          12 8 2 4 6 10                     </div> 35 Nm 60 Nm 2 x 90° 90° warm/ chaud/calinte	<b>074 103 351A</b> <b>074 103 265DV</b> <b>50 003 101</b> <small>[1]</small> <b>50 003 401</b> <small>[1]</small>
Ventilsitzringe	Bemerkungen	Zylinderkopf	Stößel
Ventilführungen		Kipp- / Schleppebel	Nockenwellen

\*siehe Abkürzungsverzeichnis

VENTILE

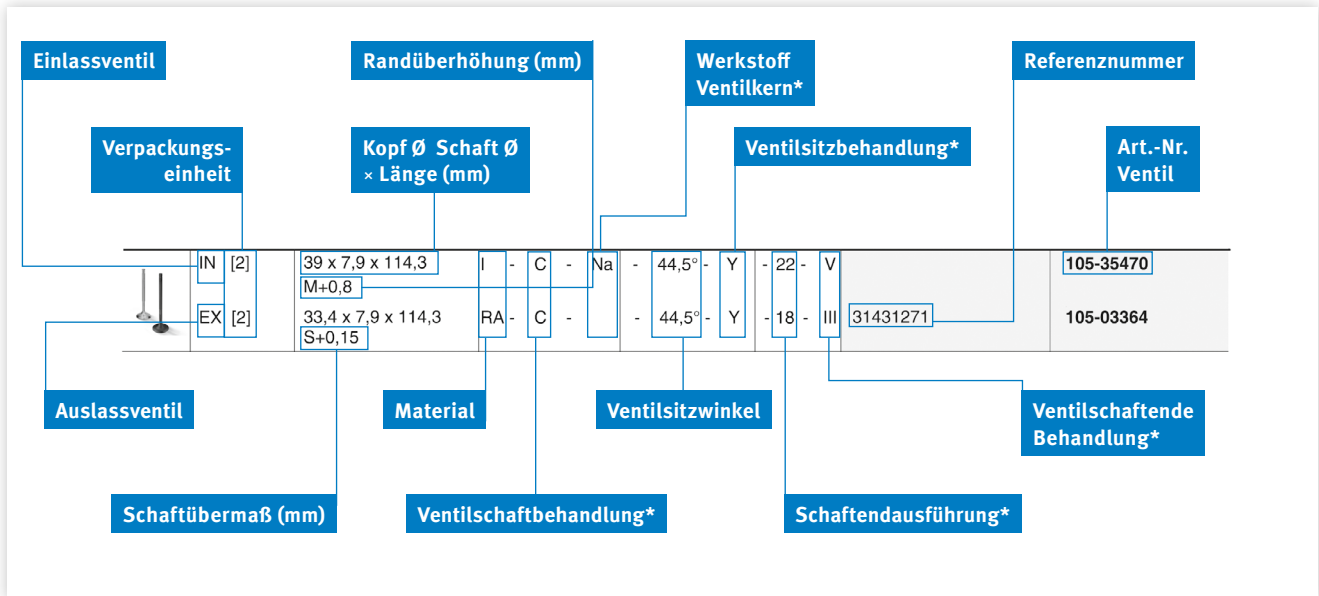

VENTILKEGELSTÜCKE

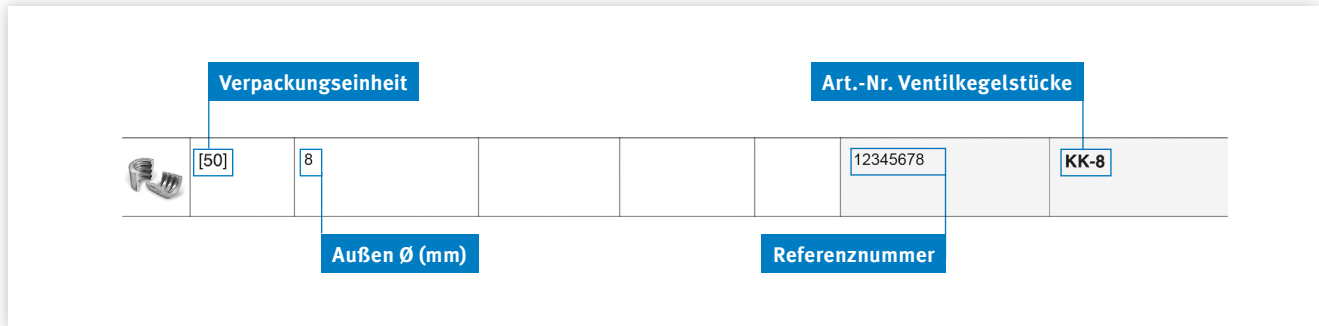

VENTILFÜHRUNGEN

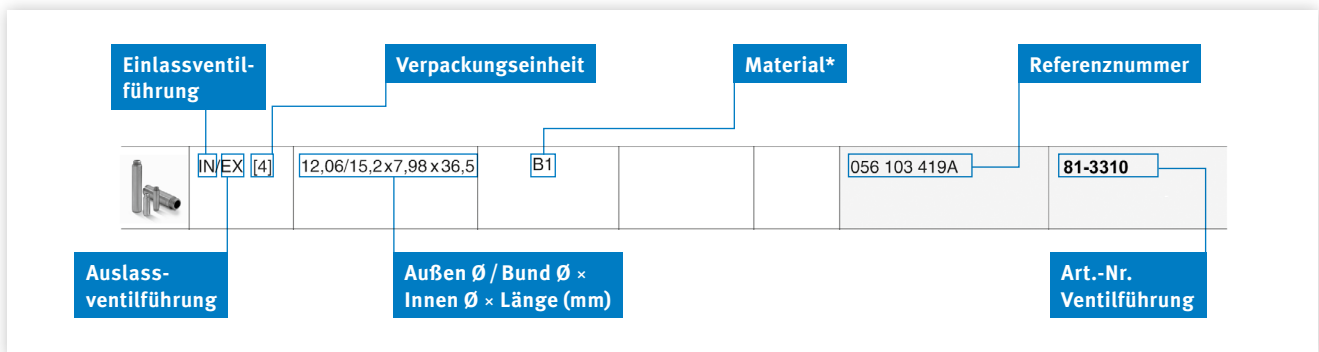

\*siehe Abkürzungsverzeichnis

**VENTILSITZRINGE**

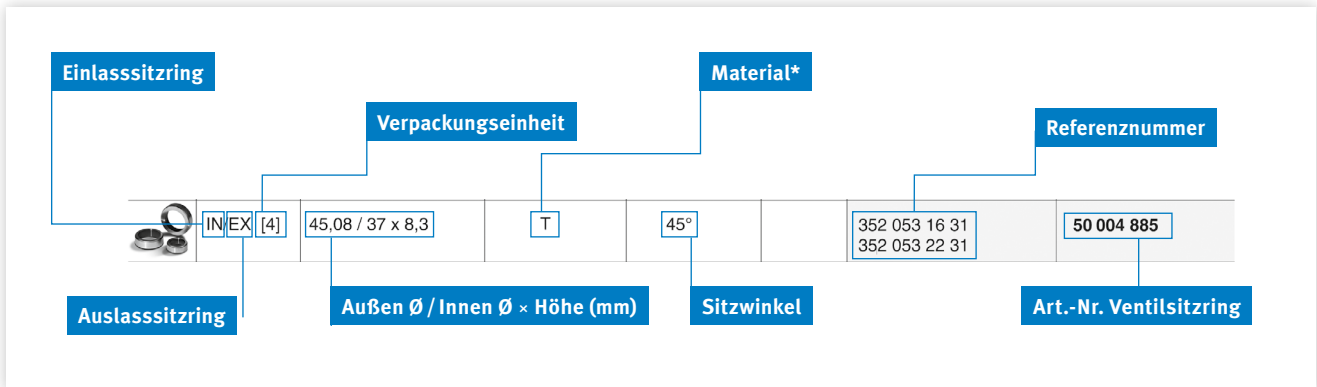

**NOCKENWELLEN**

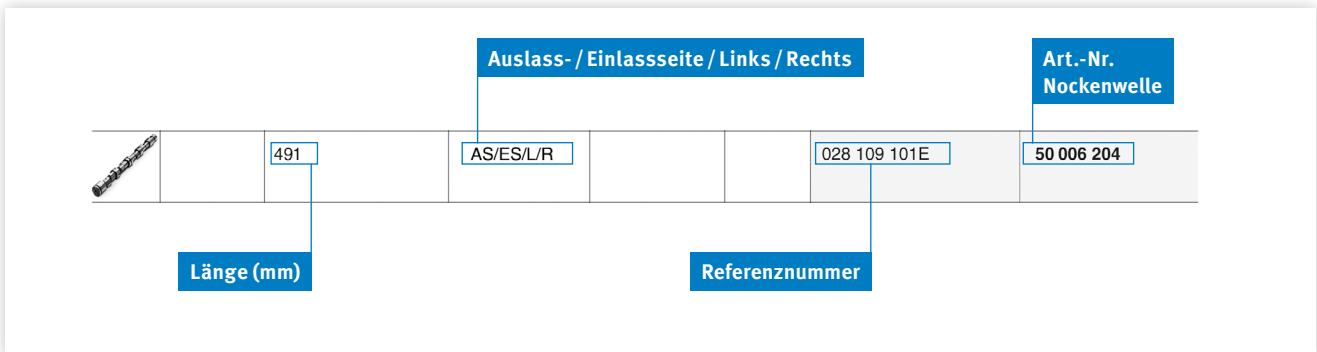

**STÖßEL**

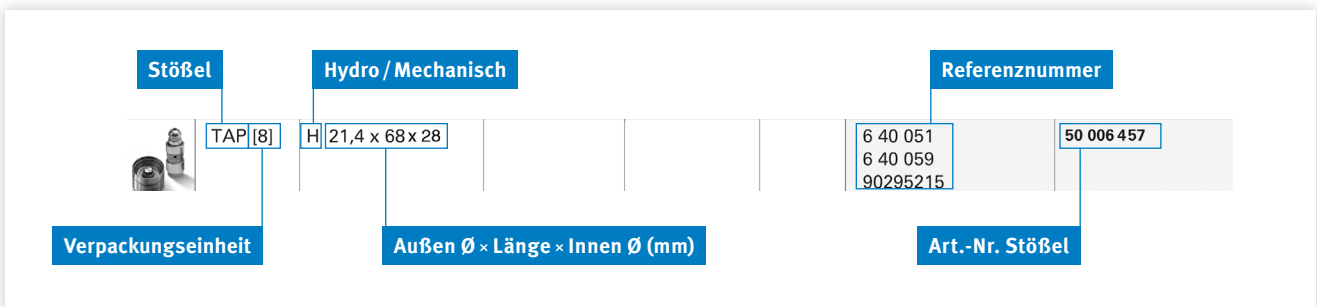

KIPP-/SCHLEPPHEBEL

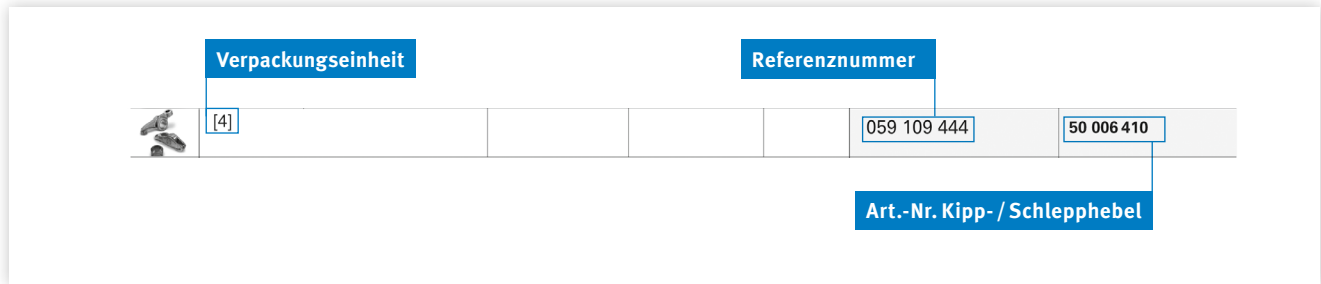

ZYLINDERKOPF

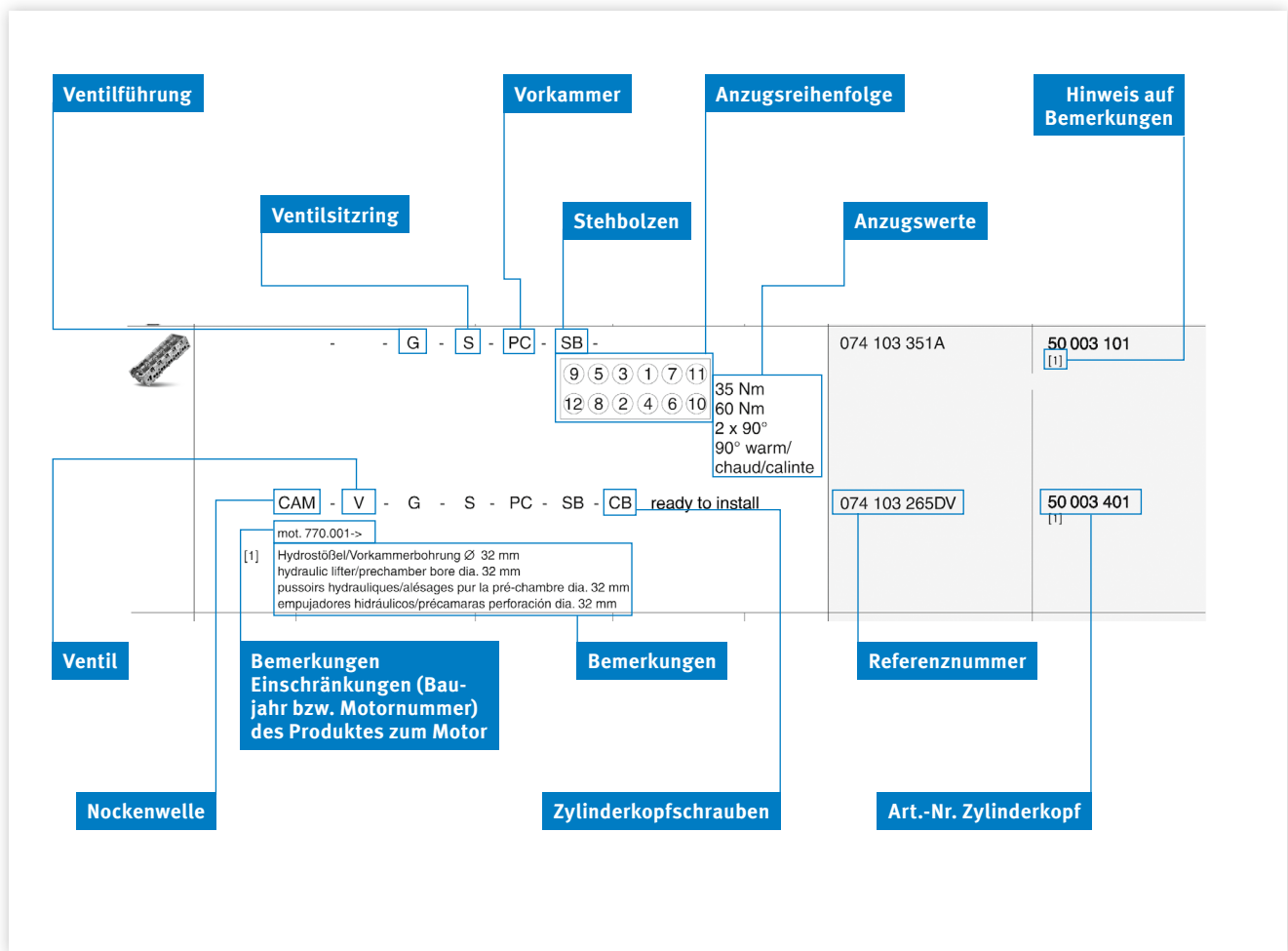



### 3. VENTILKEGELSTÜCKE – AUSFÜHRUNGEN UND ABMESSUNGEN

Material	Beschreibung	Ausführung	Ventilschaft $\emptyset$	Einsatzgehärtet	Anzahl der Rillen
KK-6H	Einrillenkegelstück	klemmend	6	gehärtet	1
KK-7H	Einrillenkegelstück	klemmend	7	gehärtet	1
KK-8H	Einrillenkegelstück	klemmend	8	gehärtet	1
KK-9H	Einrillenkegelstück	klemmend	9	gehärtet	1
KK-10H	Einrillenkegelstück	klemmend	10	gehärtet	1
KK-11H	Einrillenkegelstück	klemmend	10	gehärtet	1
KK-12H	Einrillenkegelstück	klemmend	12	gehärtet	1
LK-5H	Einrillenkegelstück	klemmend	5	gehärtet	1
LK-5.5H	Einrillenkegelstück	klemmend	5,5	gehärtet	1
LK-6H	Einrillenkegelstück	klemmend	6	gehärtet	1
LK-7H	Einrillenkegelstück	klemmend	7	gehärtet	1
LK-1610	Einrillenkegelstück	klemmend	12	nicht gehärtet	1
LK-2607	Einrillenkegelstück	klemmend	7	gehärtet	1
LK-2615	Einrillenkegelstück	klemmend	9	nicht gehärtet	1
MK-5H	Mehrrillenkegelstück	nicht klemmend	5	gehärtet	3
MK-5.5H	Mehrrillenkegelstück	nicht klemmend	5,5	gehärtet	3
MK-6H	Mehrrillenkegelstück	nicht klemmend	6	gehärtet	3
MK-7H	Mehrrillenkegelstück	nicht klemmend	7	gehärtet	3
MK-7H2	Mehrrillenkegelstück	nicht klemmend	7	gehärtet	2
MK-8H	Mehrrillenkegelstück	nicht klemmend	8	gehärtet	3
MK-9H	Mehrrillenkegelstück	nicht klemmend	9	gehärtet	3
MK-10H	Mehrrillenkegelstück	nicht klemmend	10	gehärtet	4
MK-12H	Mehrrillenkegelstück	nicht klemmend	12	gehärtet	4
RK-7	Einrillenkegelstück	klemmend	7	nicht gehärtet	1
RK-7H	Einrillenkegelstück	klemmend	7	gehärtet	1
RK-8	Einrillenkegelstück	klemmend	8	nicht gehärtet	1
RK-8H	Einrillenkegelstück	klemmend	8	gehärtet	1
RK-9H	Einrillenkegelstück	klemmend	9	gehärtet	1
RK-10H	Einrillenkegelstück	klemmend	10	gehärtet	1
RK-11H	Einrillenkegelstück	klemmend	11	gehärtet	1
RK-9.5H	Einrillenkegelstück	klemmend	9,5	gehärtet	1

#### Rillenkegelstücke KK

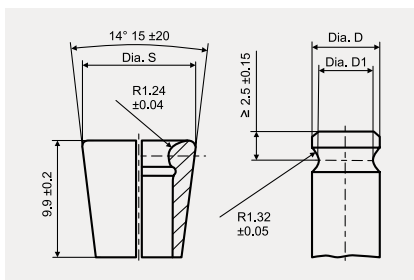

Rillenkegelstücke KK, Konus 1:4

Kurzbezeichnung		Maße des Ventilschaftendes					
Nicht gehärtet	Einsatzgehärtet	$\emptyset S \pm 0.06$	$\emptyset D$ Nennmaß	Bevorzugter Bereich $\emptyset D$		$\emptyset D1$	Gewicht (g)
				von	bis		
KK 6	KK 6H	10	6	5.99	5.89	$4.85 \pm 0.05$	1.17
KK 7	KK 7H	11	7	6.99	6.89	$5.85 \pm 0.05$	1.37
KK 8	KK 8H	12	8	7.99	7.89	$6.83 \pm 0.07$	1.55
KK 9	KK 9H	13	9	8.99	8.89	$7.8 \pm 0.1$	1.73
KK 10	KK 10H	14	10	9.99	9.89	$8.8 \pm 0.1$	1.90
KK 11	KK 11H	15	11	10.99	10.89	$9.8 \pm 0.1$	2.00
KK 12	KK 12H	16	12	11.99	11.89	$10.8 \pm 0.1$	2.24

**Rillenkegelstücke LK**

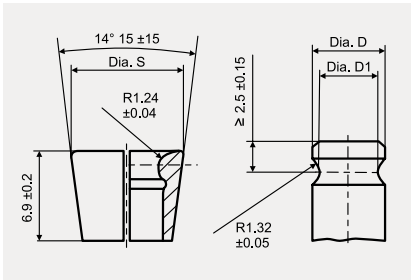

Rillenkegelstücke LK, Konus 1:4

Kurzbezeichnung			Maße des Ventilschaftendes				
Nicht gehärtet	Einsatz-gehärtet	Ø S ± 0.06	Ø D Nennmaß	Bevorzugter Bereich Ø D		Ø D1	Gewicht (g)
LK 5.5	LK 5.5H	8.5	5.5	5.49	5.39	4.35 ± 0.05	0.58
LK 6	LK 6H	9	6	5.99	5.89	4.85 ± 0.05	0.64
LK 6.5	LK 6.5H	9.5	6.5	6.49	6.39	5.35 ± 0.05	0.69
LK 7	LK 7H	10	7	6.99	6.89	5.85 ± 0.05	0.73

**Rillenkegelstücke RK**

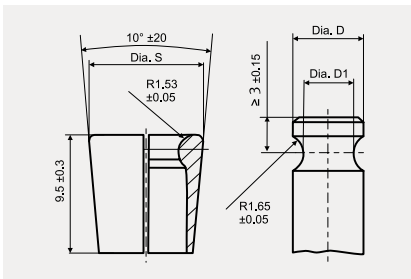

Rillenkegelstücke RK, Konus 1:4

Kurzbezeichnung			Maße des Ventilschaftendes				
Nicht gehärtet	Einsatz-gehärtet	Ø S ± 0.06	Ø D Nennmaß	Bevorzugter Bereich Ø D		Ø D1	Gewicht (g)
RK 6	RK 6H	8.79	6	5.99	5.89	4.15 ± 0.05	0.77
RK 7	RK 7H	9.79	7	6.99	6.89	5.15 ± 0.05	0.91
RK 8	RK 8H	10.79	8	7.99	7.89	6.13 ± 0.07	1.09
RK 9	RK 9H	11.79	9	8.99	8.89	7.1 ± 0.1	1.19
RK 10	RK 10H	12.79	10	9.99	9.89	8.1 ± 0.1	1.30
RK 11	RK 11H	13.79	11	10.99	10.89	9.1 ± 0.1	1.46
RK 12	RK 12H	14.79	12	11.99	11.89	10.1 ± 0.1	1.58

**Mehrrillenkegelstück MK 5-6**

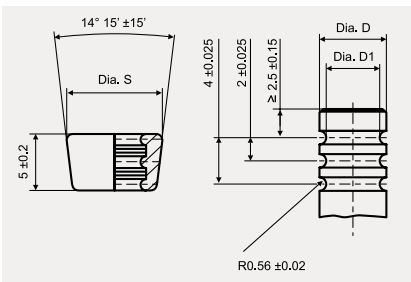

Mehrrillenkegelstück MK 5-6, Konus 1:4

Type	Anzahl der Wülste	Ø D ± 0.02	Ø D1	Ø S ± 0.05	Gewicht (g)
MK 5	3	4.92	3.91 ± 0.05	7.0	0.30
MK 5.5	3	5.42	4.41 ± 0.05	7.5	0.35
MK 6	3	5.92	4.59 ± 0.05	8.5	0.49
MK 7	3	6.92	5.25 ± 0.05	10.5	1.12
MK 8	3	7.92	6.23 ± 0.07	11.5	1.27
MK 9	3	8.92	7.20 ± 0.1	12.5	1.40

**Mehrrillenkegelstück MK 10-12**

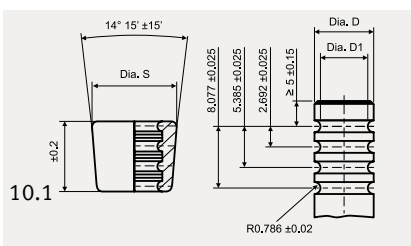

Mehrrillenkegelstück MK 10-12, Konus 1:4

Type	Anzahl der Wülste	Ø D ± 0.02	Ø D1	Ø S ± 0.05	Gewicht (g)
MK 10	4	9.92	8.20 ± 0.1	13.8	2.04
MK 11	4	10.92	9.20 ± 0.1	14.8	2.19
MK 12	4	11.92	10.20 ± 0.1	15.8	2.82

## 4. VENTILSITZRINGE – ANWENDUNGSEMPFEHLUNGEN UND EINBAUHINWEISE

### ÜBERSICHT

	HM (High Machinability)	HT (High Temperature Resistance)	HT+ (High Temperature Resistance)	G1 (High Temperature Resistance)	G2 (Highly wear-resistant)
Kraftstoffart / Verbrennung	Otto (bleifrei), Diesel	Otto (bleifrei), Diesel	Otto (bleifrei), Diesel, CNG, LPG, Propangas, Flex Fuel	Otto (bleifrei), Diesel	CNG, LPG, Flex Fuel, Otto (bleifrei), Diesel
Materialien Zylinderkopf	Aluminium, Grauguss	Aluminium, Grauguss	Aluminium, Grauguss	Aluminium, Grauguss	Aluminium, Grauguss
Motoren	leistungsarme Otto- und Dieselmotoren mit geringer bis normaler Beanspruchung	leistungsstarke, hochaufgeladene und hochbeanspruchte Otto- und Dieselmotoren	Gasanwendungen wie LPG, CNG, Propangas, Flex Fuel; leistungsstarke Otto- und Dieselmotoren	Saugmotoren, Turbomotoren	hochbeanspruchte Motoren, leistungs- gesteigerte Motoren, alle o.g. Gasmotoren

#### ACHTUNG

Extreme Einsatzbedingungen sowie hohe Belastungen des jeweiligen Motors müssen in Betracht gezogen werden und liegen im Verantwortungsbereich des Motoreninstandsetzers.

#### HINWEIS

Ein Austausch von Ventilsitzringen und Ventilen im Rahmen der Gasumrüstung stellt immer ein Eingriff in die originalen Motorspezifikationen dar. Ob die neuen Materialpaarungen harmonieren und sich die gewünschten Ergebnisse unter den geänderten Bedingungen einstellen, lässt sich im Vorfeld nur abschätzen. Extreme Einsatzbedingungen und die spezifischen Motorenbelastungen müssen in Betracht gezogen werden. Diese liegen im alleinigen Verantwortungsbereich des Motorenumrüsters.

### KOLBENSCHMIDT / TRW ENGINE COMPONENTS EMPFIEHLT FOLGENDE ÜBERDECKUNGEN / PRESSPASSUNGEN

Außendurchmesser Sitzring		Zylinderkopf aus Gusseisen		Zylinderkopf aus Aluminium	
[mm]	[inch]	[mm]	[inch]	[mm]	[inch]
20 – 30	0.7874 – 1.1811	0,06	0.0024	0,08	0.0031
30 – 40	1.1811 – 1.5748	0,08	0.0031	0,10	0.0040
40 – 50	1.5748 – 1.9685	0,10	0.0040	0,12	0.0047
50 – 60	1.9685 – 2.3622	0,12	0.0047	0,14	0.0055
60 – 70	2.3622 – 2.7559	0,14	0.0055	0,16	0.0063

Um Ihnen stets ein vollständiges Programm bieten zu können, wird unser Sortiment regelmäßig durch neue Typen ergänzt. Bitte fragen Sie Ihren Ansprechpartner. Er wird Sie über den aktuellen Stand informieren.

Die Werkstoffe der Ventile und Ventilführungen sind mit den Sitzringen aufeinander abgestimmt und gewährleisten einen optimalen Einsatz.

#### Bestellhinweis

Sollten Sie ein weiteres, nicht in der Liste aufgeführtes Maß benötigen, fragen Sie bitte Ihren Ansprechpartner. Jede nicht aufgeführte Abmessung kann innerhalb von 14 Wochen auf Anfrage angefertigt werden.





**IMPORTANT INFORMATION**

All information in this catalogue is non-binding. We cannot accept any liability for correctness and completeness. We always welcome feedback about any errors in the catalogue and will correct them in future editions.

Names, descriptions and numbers of vehicles or manufacturers etc. are listed for comparison purposes only, as are the original part numbers of vehicle and engine manufacturers. These are not designations of origin and may not be used for third parties. Please also note that changes may be made to the equipment or to designations by the vehicle or engine manufacturers. We therefore cannot accept any liability for the use of the comparison lists.

We expressly reserve the right to change the product specifications, materials, appearance and scope of supply of our products at any time. The images in the catalogue are therefore non-binding.

Before installation, always check whether the product purchased is suitable for the intended use. Our information cannot be used to make a claim about a specific quality or suitability for a specific intended purpose. In particular, it should be noted that the products offered in the catalogue are not intended for use in aircraft and spacecraft. When used in off-highway engines (e.g. marine, stationary or train engines), please note that the same engine designation may be used for different engine parts (e.g. pistons). Therefore, before installing the products, it may be necessary to seek expert advice from the manufacturer or an authorised repair shop. We would also like to point out that the installation must always be carried out by trained, qualified personnel. Images, schematic diagrams and other information are for explanation and illustration purposes and must not be used as a basis for installation.

Any duplication, imitation, distribution or public reproduction of this catalogue, even in part, is permitted only with our prior written consent and a corresponding reference to the source. The publication of this catalogue renders all previous editions invalid.

**CERTIFICATIONS**

MS Motorservice International GmbH has an ISO 9001 certified quality management system and an ISO 14001 certified environmental management system.



ENGLISH



THE CONTENTS OF THE CATALOGUE ARE ALSO AVAILABLE IN OUR ONLINE CATALOGUE, IN OUR APP AND ON TECALLIANCE.

**Further information:**  
[catalog.ms-motorservice.com](http://catalog.ms-motorservice.com)  
[motorservice.app](http://motorservice.app)

**TABLE OF CONTENTS**

	<b>PAGE</b>
Important information	20
Quality management	20
Know-how transfer – professional knowledge from the expert	22
1. Valve train components and cylinder heads	25
2. <b>INSTRUCTIONS FOR USING THE CATALOGUE</b>	<b>28</b>
3. Valve cotters – designs and dimensions	34
4. Recommended uses and fitting instructions	36
5. Lists of dimensions valve seat inserts	109
5.1 Sorted by exterior diameter D (mm)	110
5.2 Sorted by exterior diameter D (inch)	117
6. Addition to the range	123
7. List of manufacturers	139
8. <b>PRODUCT RANGE</b>	<b>141</b>
9. Kolbenschmidt / BF / TRW Engine Components no. – applications	1419
10. Reference list	1457
11. Procedure for claims / claims form	

**MOTORSERVICE GROUP**
**QUALITY AND SERVICE FROM A SINGLE SOURCE**

The Motorservice Group is the sales organisation for the global aftermarket activities of Rheinmetall. It is a leading supplier of engine components for the independent aftermarket. With the premium brands Kolbenschmidt, Pierburg, TRW Engine Components and the brands BF and turbo by Intec, Motorservice offers its trade and repair shop customers a wide and comprehensive range of top-quality products.

**RHEINMETALL**
**TECHNOLOGY FOR FUTURE MOBILITY**

As a global supplier to the automotive industry, Rheinmetall's expertise in air supply systems, emission control and pumps and in the development, manufacture and spare parts supply of pistons, engine blocks and engine bearings puts it right at the top of the markets. Product development is carried out in close cooperation with well-known automotive manufacturers.

# KNOW-HOW TRANSFER

## PROFESSIONAL KNOWLEDGE FROM THE EXPERTS

### WORLDWIDE TRAININGS

#### Direct from the manufacturer

Each year, around 4,500 mechanics and engineers benefit from our training courses and seminars, which we hold on-site in locations across the world or in our training centres in Neuenstadt, Dormagen and Tamm (Germany).

### TECHNICAL INFORMATION

#### From practical experience for practical use

Our Product Information and Service Information publications, technical brochures and posters keep you at the forefront of the latest technological developments.

### TECHNICAL VIDEOS

#### Knowledge transfer via video

Our videos provide you with useful information on our products, such as hands-on fitting instructions and system descriptions.



### PRODUCTS IN FOCUS ONLINE

#### Our solutions explained clearly

Interactive elements, animations and video clips provide interesting information about our products in and around the engine.

### ONLINESHOP

#### Your direct access to our products

Order at any time. Quick availability check. Extensive product search by engine, vehicle, dimensions etc.

### NEWS

#### Regular information via e-mail

Subscribe online to our free newsletter now and receive regular information about additions to the product range, technical publications and much more.

### INDIVIDUAL INFORMATION

#### Especially for our customers

We provide extensive information and services relating to our wide range of services: e.g. personalised sales-promoting materials, sales support, technical support and much more.



### TECHNIPEDIA

#### Technical information on all aspects of the engine

We share our know-how with you in our Technipedia. You can get professional knowledge direct from experts here.

### MOTORSERVICE APP

#### Access technical know-how on the move

Here, you will find the latest information and services relating to our products quickly and easily.

### SOCIAL MEDIA

#### Always up to date



[www.ms-motorservice.com](http://www.ms-motorservice.com)







# 1. VALVE TRAIN COMPONENTS AND CYLINDER HEADS

## VALVES

### Quality and safety over a great distance

The valves experience around 200 million load changes over an operating time of 200,000 km. This is why valves from TRW Engine Components are designed based on modern calculation methods (FEA) and are subjected to extensive tests before series release.



## VALVE GUIDES

### High-level guidance

The valve guide centres the valve on the valve seat insert under extreme conditions, also conveying some of the heat to the cylinder head. The material and its characteristics are a crucial factor under these extreme loads – play it safe and trust in the product quality of TRW Engine Components.



## VALVE SEAT INSERTS

### The right material for every application

When it comes to the increasingly high thermal and mechanical strain on the seat insert in modern engines, materials from conventional casting processes can barely cut it. That is why Motorservice offers sintered valve seat inserts using three different material combinations in addition to cast seat inserts.



## CAMSHAFTS

### Wear-resistant cams for a long, powerful engine life

To withstand the high bending and torsion forces over the long term, the camshafts in the Motorservice product range have been designed to incorporate high strength properties. Camshafts may be cast or forged, depending on their intended purpose.









## HYDRAULIC TAPPETS

### Maintenance-free, automatic balancing

The design of the hydraulic tappets dispenses with the need to check and adjust play, which reduces extensive maintenance costs as a result. Hydraulic tappets operate with virtually no play – reducing operational wear and promoting the even running and efficiency of engines.



## CONTROL ELEMENTS

### Solid connection

Only high-quality control elements permit reliable and precise force transmission between the camshaft and the cylinder head. Motorservice control elements ensure precision and durability across the entire valve control system.



## CYLINDER HEADS

### Completed to your requirements

Motorservice boasts a select product portfolio of cylinder heads for passenger cars and utility vehicles. The cylinder heads are also available with pre-assembled valves and valve-springs according to requirements and for ease of repair.





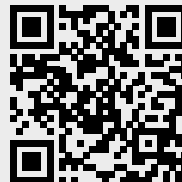

For technical information on products, installation and running-in, please visit:  
[www.ms-motorservice.com](http://www.ms-motorservice.com)



## 2. INSTRUCTIONS FOR USING THE CATALOGUE

### ENGINE INDEX

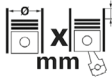





Detailed search assistance is included at the beginning of each manufacturer section. The engine designations are listed in ascending alphanumerical order.

 KOLBENSCHMIDT		<b>INDEX</b>								<b>DEUTZ</b>	
		Cyl.	 X mm	cm <sup>3</sup>		Comp. Ratio ε	kW	PS	<b>Pos</b>		
A 6 M 816		D (AN) 6	142 x 160	15204	2	16:1	145-172	197-234	45		
A 6 M 816 R		D (LA) 6	142 x 160	15204	2	16:1			45		
A 6 M 816 U		D (LA) 6	142 x 160	15204	2	16:1			45		
A 6 M 816 W		D (LA) 6	142 x 160	15204	2	16:1			45		

**Engine** **Item number**

### VEHICLE INDEX

Detailed search assistance is included at the beginning of each manufacturer section. The vehicles are listed in ascending alphanumerical order after vehicle class.

 KOLBENSCHMIDT		<b>INDEX</b>				<b>AUDI</b>			
 		<b>Pos</b>	 		<b>Pos</b>				
A1 (8X)			A4 1.8i Turbo 20V	01.1999 → 06.2000	ANB	B			23
1.4 TFSI 05.2010 →	CAXA	B 3	A4 1.8i Turbo 20V	06.2000 → 09.2001	AWT	B			27
2.0 TDI 09.2011 →	CFHB	D 33	A4 1.9 TDI	01.1995 → 07.1996	1Z	D			11
A2 (8Z)			A4 1.9 TDI	03.1996 → 07.1999	AFN	D			11

**Vehicle / model series** **Item number**

ENGINE LINE

<b>Item number</b> (sequential numbering for a manufacturer)	<b>Model year from → to</b>	<b>Piston families for the listed engines.</b> See piston catalogue for details on use.	<b>Compression ratio</b>
<b>Cylinder nominal Ø</b>	<b>Type of charging*</b>		<b>Stroke</b>
24	115 Cyl. 6	93 152 6... 91 151 6..	
<b>D 5TC EURO 1</b>	03.1988 -> 04.1994	D [AN] 6	7800 cm3
(1) Conrod length = 220 mm	mot. -> 456789		2V
			178 KW (242 PS)
			16:1
			125 mm
			(1)
<b>Comments</b>	<b>Engine number / identification number</b>	<b>Number of cylinders</b>	<b>Displacement</b>
PL	St/A 50,000	53,708 53.695	29,00
		1,822	STD 0.30
			4
			77 099 608
			<b>Reference to comments</b>
		<b>Type of fuel*</b>	<b>Engine rating from → to</b>
<b>Engine designation with type of catalytic converter / type of pollutant</b>			<b>Number of valves</b>

\* see list of abbreviations



PRODUCT DATA

The catalogue pages consist of the information blocks shown:

ENGLISH

Item number	Pictogram line	Engine line	Manufacturer box	Valves
				Manufacturer
				Reference
<b>24</b>		<b>115 Cyl. 6</b>		
<b>D 5TC EURO 1</b>		<b>03.1988 -&gt; 04.1994</b>	<b>D [AN] 6</b>	<b>7800 cm3</b>
[1] Conrod length = 220 mm 94 347 6.		mot. -> 456789	<b>2V</b>	<b>178 kW (242 PS)</b>
		<b>16:1</b>	<b>125 mm</b> [1]	
	IN [2] 39 x 7,9 x 114,3 M+0,8 EX [2] 33,4 x 7,9 x 114,3 S+0,15	I - C - Na - 44,5° - Y - 22 - V RA - C - - 44,5° - Y - 18 - III	31431271	105-35470 105-03364
	[50] 8		12345678	KK-8
	IN/EX [4] 12,06/15,2x7,98 x36,5	B1	056 103 419A	81-3310
	IN/EX [4] 45,08 / 37 x 8,3	T 45°	352 053 16 31 352 053 22 31	50 004 885
	491	AS/ES/L/R	028 109 101E	50 006 204
	TAP [8] H 21,4 x 68 x 28		6 40 051 6 40 059 90295215	50 006 457
	[4]		059 109 444	50 006 410
	- - G - S - PC - SB -  CAM - V - G - S - PC - SB - CB ready to install mot. 770.001-> [1] Hydrosößel/Vorkammerbohrung Ø 32 mm hydraulic lifter/prechamber bore dia. 32 mm poussoirs hydrauliques/alésages pur la pré-chambre dia. 32 mm empuñadores hidráulicos/précamaras perforación dia. 32 mm	9 5 3 1 7 11 12 8 2 4 6 10 35 Nm 60 Nm 2 x 90° 90° warm/ chaud/calinte	074 103 351A  074 103 265DV	50 003 101 [1]  50 003 401 [1]

\*see list of abbreviations

VALVES

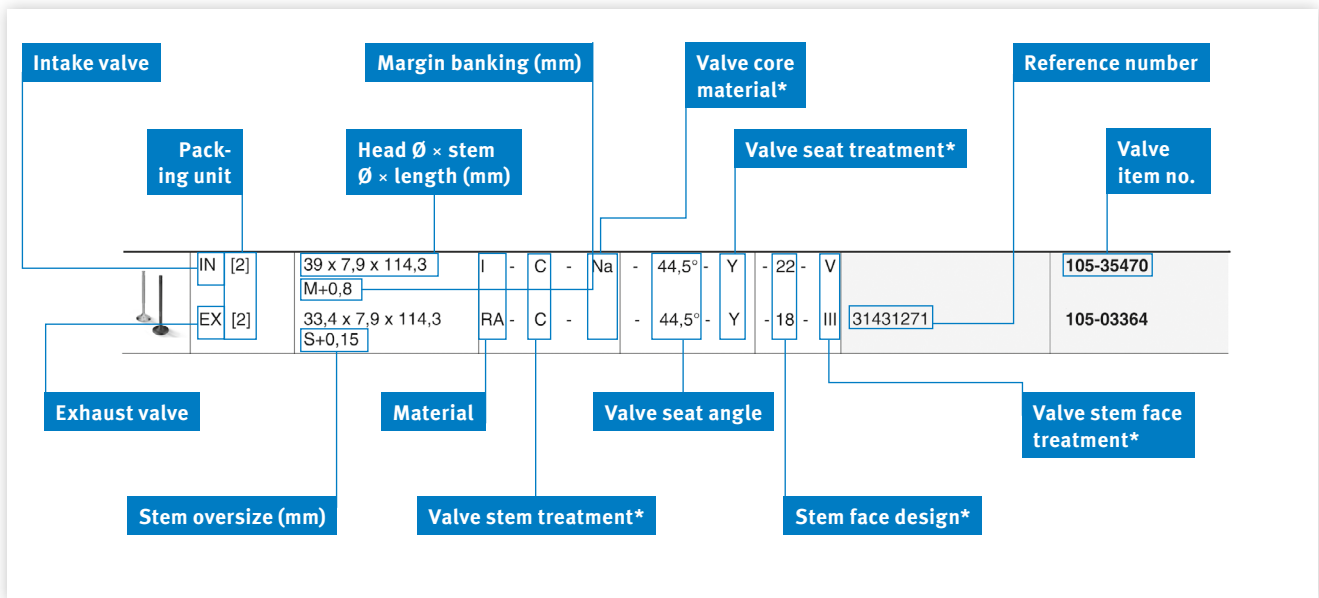

VALVE COTTERS

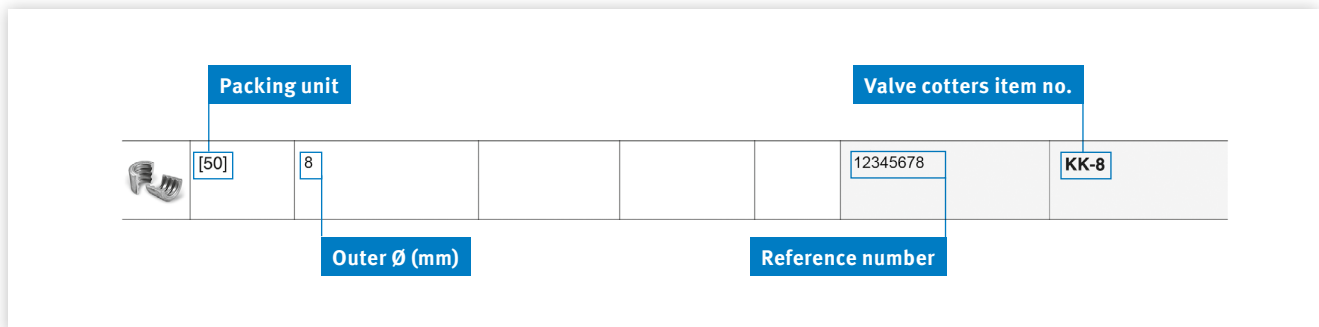

VALVE GUIDES

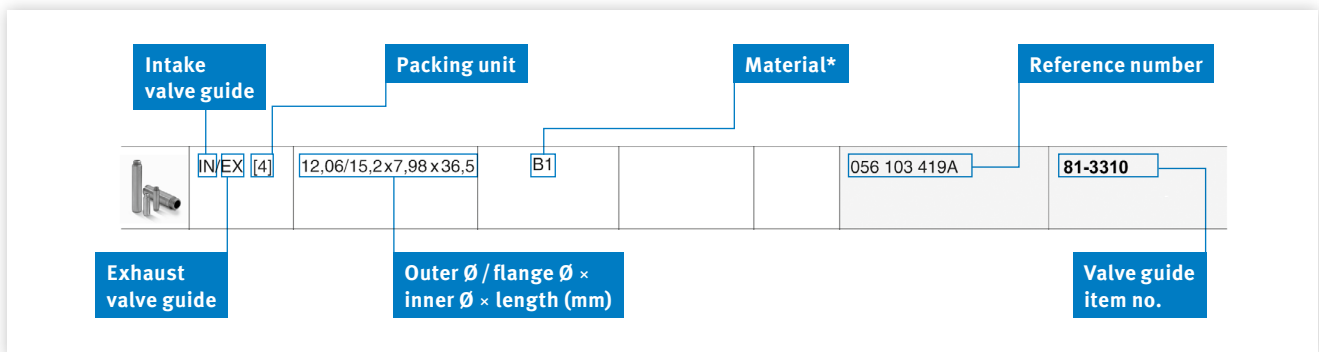

ENGLISH

\*see list of abbreviations

VALVE SEAT INSERTS

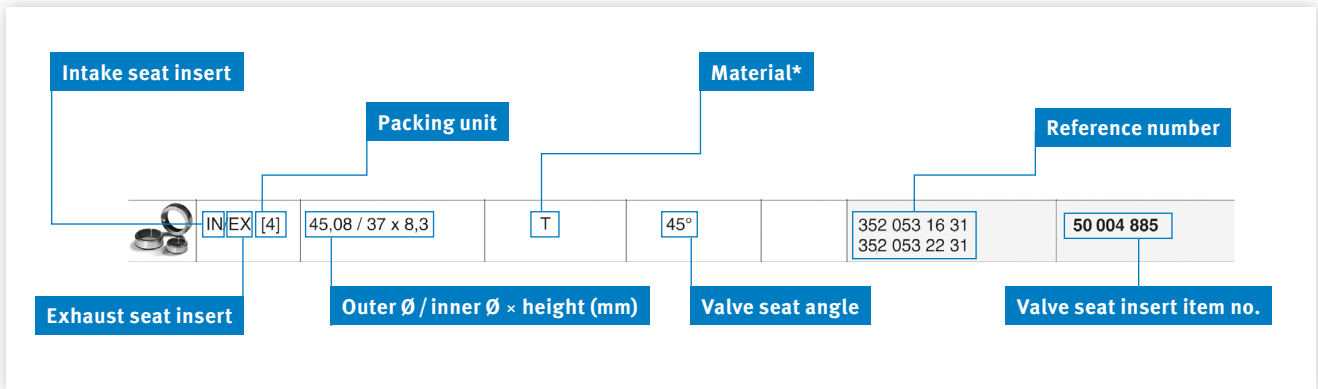

CAMSHAFTS

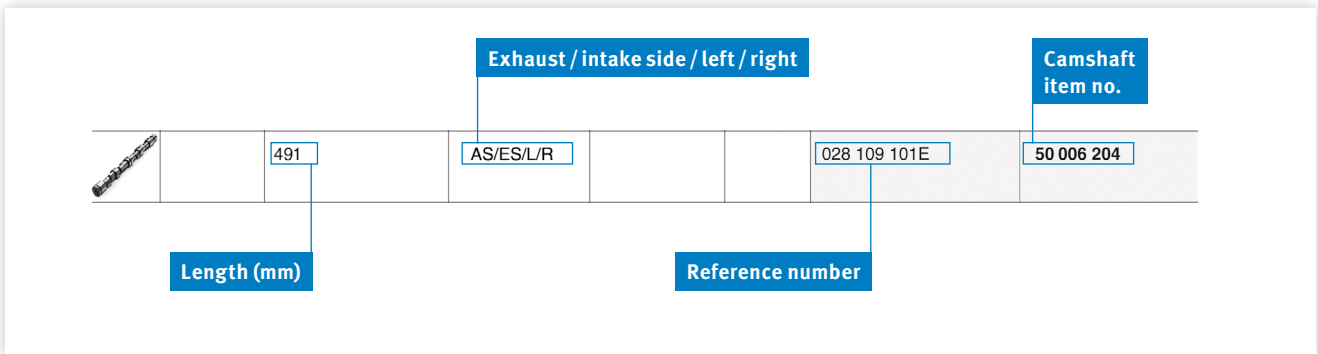

TAPPETS

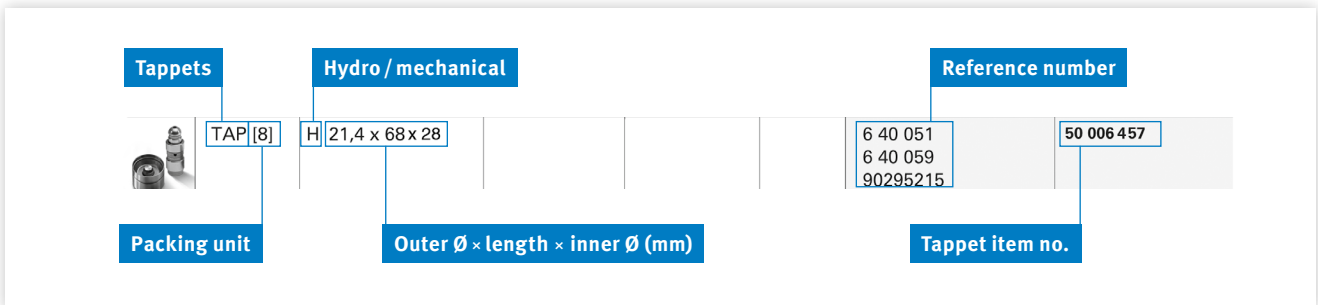





### 3. VALVE COTTERS – DESIGNS AND DIMENSIONS

Material	Description	Version	Valve stem $\varnothing$	Case hardened	Number of grooves
KK-6H	Single-groove cotter	Clamping	6	Hardened	1
KK-7H	Single-groove cotter	Clamping	7	Hardened	1
KK-8H	Single-groove cotter	Clamping	8	Hardened	1
KK-9H	Single-groove cotter	Clamping	9	Hardened	1
KK-10H	Single-groove cotter	Clamping	10	Hardened	1
KK-11H	Single-groove cotter	Clamping	10	Hardened	1
KK-12H	Single-groove cotter	Clamping	12	Hardened	1
LK-5H	Single-groove cotter	Clamping	5	Hardened	1
LK-5.5H	Single-groove cotter	Clamping	5.5	Hardened	1
LK-6H	Single-groove cotter	Clamping	6	Hardened	1
LK-7H	Single-groove cotter	Clamping	7	Hardened	1
LK-1610	Single-groove cotter	Clamping	12	Not hardened	1
LK-2607	Single-groove cotter	Clamping	7	Hardened	1
LK-2615	Single-groove cotter	Clamping	9	Not hardened	1
MK-5H	Multi-groove cotter	Non-clamping	5	Hardened	3
MK-5.5H	Multi-groove cotter	Non-clamping	5.5	Hardened	3
MK-6H	Multi-groove cotter	Non-clamping	6	Hardened	3
MK-7H	Multi-groove cotter	Non-clamping	7	Hardened	3
MK-7H2	Multi-groove cotter	Non-clamping	7	Hardened	2
MK-8H	Multi-groove cotter	Non-clamping	8	Hardened	3
MK-9H	Multi-groove cotter	Non-clamping	9	Hardened	3
MK-10H	Multi-groove cotter	Non-clamping	10	Hardened	4
MK-12H	Multi-groove cotter	Non-clamping	12	Hardened	4
RK-7	Single-groove cotter	Clamping	7	Not hardened	1
RK-7H	Single-groove cotter	Clamping	7	Hardened	1
RK-8	Single-groove cotter	Clamping	8	Not hardened	1
RK-8H	Single-groove cotter	Clamping	8	Hardened	1
RK-9H	Single-groove cotter	Clamping	9	Hardened	1
RK-10H	Single-groove cotter	Clamping	10	Hardened	1
RK-11H	Single-groove cotter	Clamping	11	Hardened	1
RK-9.5H	Single-groove cotter	Clamping	9.5	Hardened	1

**Groove cotters KK**

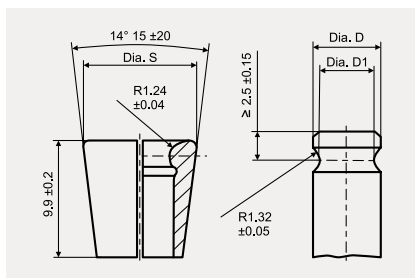

Groove cotters KK, cone 1:4

Code	Dimensions of valve stem face						Weight (g)
	Not hardened	Case hardened	$\varnothing S \pm 0.06$	$\varnothing D$ nominal dimension	Preferred range $\varnothing D$	$\varnothing D1$	
				from	to		
KK 6	KK 6H	10	6	5.99	5.89	4.85 ± 0.05	1.17
KK 7	KK 7H	11	7	6.99	6.89	5.85 ± 0.05	1.37
KK 8	KK 8H	12	8	7.99	7.89	6.83 ± 0.07	1.55
KK 9	KK 9H	13	9	8.99	8.89	7.8 ± 0.1	1.73
KK 10	KK 10H	14	10	9.99	9.89	8.8 ± 0.1	1.90
KK 11	KK 11H	15	11	10.99	10.89	9.8 ± 0.1	2.00
KK 12	KK 12H	16	12	11.99	11.89	10.8 ± 0.1	2.24

**Groove cotters LK**

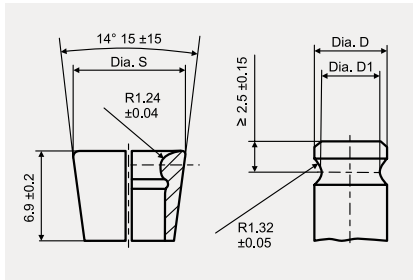

Groove cotters LK, cone 1:4

Code		Dimensions of valve stem face					
Not hardened	Case hardened	Ø S ± 0.06	Ø D nominal dimension	Preferred range Ø D		Ø D1	Weight (g)
LK 5.5	LK 5.5H	8.5	5.5	5.49	5.39	4.35 ± 0.05	0.58
LK 6	LK 6H	9	6	5.99	5.89	4.85 ± 0.05	0.64
LK 6.5	LK 6.5H	9.5	6.5	6.49	6.39	5.35 ± 0.05	0.69
LK 7	LK 7H	10	7	6.99	6.89	5.85 ± 0.05	0.73

**Groove cotters RK**

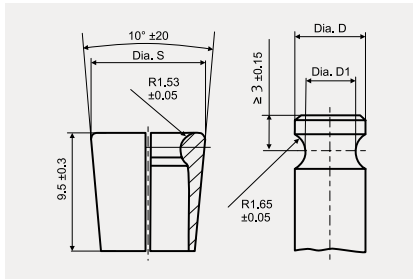

Groove cotters RK, cone 1:4

Code		Dimensions of valve stem face					
Not hardened	Case hardened	Ø S ± 0.06	Ø D nominal dimension	Preferred range Ø D		Ø D1	Weight (g)
RK 6	RK 6H	8.79	6	5.99	5.89	4.15 ± 0.05	0.77
RK 7	RK 7H	9.79	7	6.99	6.89	5.15 ± 0.05	0.91
RK 8	RK 8H	10.79	8	7.99	7.89	6.13 ± 0.07	1.09
RK 9	RK 9H	11.79	9	8.99	8.89	7.1 ± 0.1	1.19
RK 10	RK 10H	12.79	10	9.99	9.89	8.1 ± 0.1	1.30
RK 11	RK 11H	13.79	11	10.99	10.89	9.1 ± 0.1	1.46
RK 12	RK 12H	14.79	12	11.99	11.89	10.1 ± 0.1	1.58

**Multi-groove cotter MK 5-6**

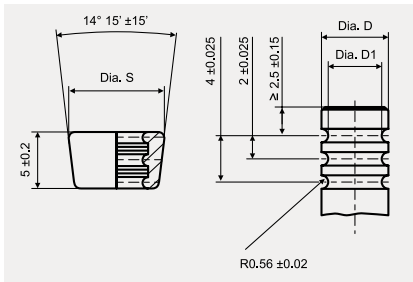

Multi-groove cotter MK 5-6, cone 1:4

Type	Number of bulges	Ø D ± 0.02	Ø D1	Ø S ± 0.05	Weight (g)
MK 5	3	4.92	3.91 ± 0.05	7.0	0.30
MK 5.5	3	5.42	4.41 ± 0.05	7.5	0.35
MK 6	3	5.92	4.59 ± 0.05	8.5	0.49
MK 7	3	6.92	5.25 ± 0.05	10.5	1.12
MK 8	3	7.92	6.23 ± 0.07	11.5	1.27
MK 9	3	8.92	7.20 ± 0.1	12.5	1.40

**Multi-groove cotter MK 10-12**

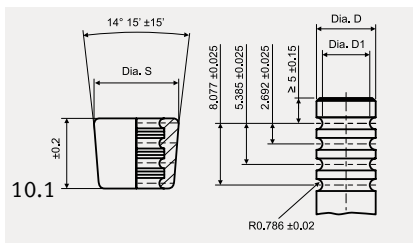

Multi-groove cotter MK 10-12, cone 1:4

Type	Number of bulges	Ø D ± 0.02	Ø D1	Ø S ± 0.05	Weight (g)
MK 10	4	9.92	8.20 ± 0.1	13.8	2.04
MK 11	4	10.92	9.20 ± 0.1	14.8	2.19
MK 12	4	11.92	10.20 ± 0.1	15.8	2.82

# 4. VALVE SEAT INSERTS – RECOMMENDED USES AND FITTING INSTRUCTIONS

## OVERVIEW

	HM (High Machinability)	HT (High Temperature Resistance)	HT+ (High Temperature Resistance)	G1 (High Temperature Resistance)	G2 (Highly wear-resistant)
Type of fuel/ combustion	Petrol (unleaded), diesel	Petrol (unleaded), diesel	Petrol (unleaded), diesel, CNG, LPG, propane gas, Flex Fuel	Petrol (unleaded), diesel	CNG, LPG, Flex Fuel, petrol (unleaded), diesel
Cylinder head materials	Aluminium, grey cast iron	Aluminium, grey cast iron	Aluminium, grey cast iron	Aluminium, grey cast iron	Aluminium, grey cast iron
Engines	Low-performance petrol and diesel engines with low to normal strain	High-performance, highly charged, highly strained petrol and diesel engines	Utilisation of gases such as LPG, CNG, propane gas, Flex Fuel; high-performance petrol and diesel engines	Naturally aspirated engines, turbocharged engines	Highly strained engines, high-performance engines, all gas engines listed above

### ATTENTION

Extreme operating conditions and high engine stresses must be taken into consideration and remain the responsibility of the engine reconitioner.

### NOTE

Replacement of valve seat inserts and valves as part of the gas conversion always represents a change to the original engine specifications. Only an estimate can be given in advance as to whether the new material combinations will work harmoniously and achieve the required results under the modified conditions. Extreme operating conditions and the specific engine loads must be taken into consideration. These are the sole responsibility of the engine modifier.

## KOLBENSCHMIDT / TRW ENGINE COMPONENTS RECOMMENDS THE FOLLOWING PRESSFITS / PRESS FITTINGS

Seating ring outer diameter		Cast iron cylinder head		Aluminium cylinder head	
[mm]	[inch]	[mm]	[inch]	[mm]	[inch]
20 – 30	0.7874 – 1.1811	0.06	0.0024	0.08	0.0031
30 – 40	1.1811 – 1.5748	0.08	0.0031	0.10	0.0040
40 – 50	1.5748 – 1.9685	0.10	0.0040	0.12	0.0047
50 – 60	1.9685 – 2.3622	0.12	0.0047	0.14	0.0055
60 – 70	2.3622 – 2.7559	0.14	0.0055	0.16	0.0063

We regularly add new types to our products so we can offer you a full range at all times. Please speak to your contact person. They will be able to provide you with the latest information. The materials used for the valves and valve guides are tailored to the seat inserts and ensure optimal use.

### Order information

If you require a dimension that is not included in the list, please speak to your contact person. Dimensions not listed can be produced within 14 weeks on request.





## REMARQUES IMPORTANTES

Toutes les informations figurant dans ce catalogue sont fournies sans engagement de notre part. Nous déclinons toute responsabilité quant à l'exactitude et l'exhaustivité des contenus. Si vous relevez des erreurs dans ce catalogue, n'hésitez pas à nous les communiquer : nous veillerons à les corriger dans les futures éditions.

Les noms, descriptions, numéros de véhicule ou de constructeur, etc. ne sont donnés qu'à titre de comparaison, tout comme les références des pièces d'origine des constructeurs automobiles ou de moteurs. Ces informations ne doivent pas être utilisées dans le cadre de communications externes car ce ne sont pas les désignations d'origine. Il est de plus impossible d'exclure que les constructeurs automobiles ou de moteurs n'apportent des modifications aux équipements et aux désignations. Nous déclinons donc toute responsabilité pour l'utilisation des listes de correspondances.

Nous nous réservons explicitement le droit d'apporter à tout moment des modifications aux spécifications de nos produits, aux matériaux utilisés, à leur aspect et à la composition des lots. Les illustrations du catalogue n'ont donc qu'une valeur indicative.

Avant le montage, vérifiez toujours que le produit acheté est adapté à l'usage prévu. Une quelconque qualité ou aptitude à un usage particulier ne peut être déduite de nos indications. Il convient notamment de noter que les produits proposés dans le catalogue ne sont pas destinés aux applications aérospatiales. Dans le cas de l'utilisation sur des moteurs off-highway (par ex. moteurs de marine, moteurs stationnaires ou moteurs de traction), tenir compte du fait que des pièces de moteur différentes (par ex. des pistons) peuvent être utilisées pour une même désignation du moteur. Le cas échéant, demandez conseil au constructeur ou à un concessionnaire agréé avant de monter les produits. Nous rappelons que le montage doit toujours être confié à des techniciens qualifiés et formés. Les illustrations, dessins schématiques et autres indications sont destinés à expliquer et à représenter nos produits ; ils ne peuvent en aucun cas servir de base au montage des pièces.

Toute duplication, imitation, diffusion ou reproduction, même partielle, du présent catalogue sans notre consentement écrit préalable et sans indication de la source est illicite. La présente édition remplace et annule toutes les éditions précédentes du catalogue.

## CERTIFICATIONS

MS Motorservice International GmbH bénéficie d'un système de gestion de la qualité certifié conforme à ISO 9001 et d'un système de gestion de l'environnement certifié conforme à ISO 14001.





VOUS TROUVEREZ LES  
 INFORMATIONS DE CE  
 CATALOGUE DANS NOTRE  
 CATALOGUE EN LIGNE,  
 SUR NOTRE APPLICATION  
 ET SUR TECALLIANCE.

**Plus d'informations :**  
**catalog.ms-motorservice.com**  
**motorservice.app**

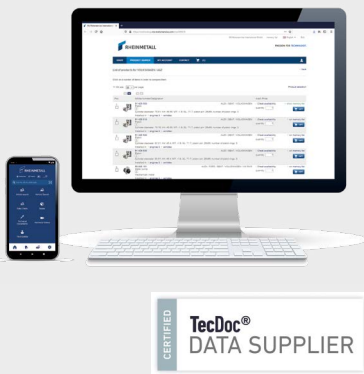
**TABLE DES MATIÈRES**
**PAGE**

	Remarques importantes	38
	Gestion de la qualité	38
	Transfert de savoir-faire – Compétence des experts	40
1.	Composants d'actionnement des soupapes et culasses	43
<b>2.</b>	<b>PRÉCISIONS SUR L'UTILISATION DU CATALOGUE</b>	<b>46</b>
3.	Demi-cônes – Modèles et dimensions	52
4.	Recommandations d'application et instructions de montage	54
5.	Listes de cotes bagues de siège de soupape	109
5.1	Classement par diamètre extérieur D (mm)	110
5.2	Classement par diamètre extérieur D (pouces)	117
6.	Complément de la gamme	123
7.	Tableau des constructeurs	139
<b>8.</b>	<b>GAMME DE PRODUITS</b>	<b>141</b>
9.	N° Kolbenschmidt / BF / TRW Engine Components – Applications	1419
10.	Liste de références	1457
11.	Marche à suivre en cas de réclamation / Formulaire de réclamation	

**GROUPE MOTORSERVICE**
**QUALITÉ ET SERVICE AUPRÈS D'UN UNIQUE FOURNISSEUR**

Le groupe Motorservice est l'organisation commerciale en charge des activités internationales Aftermarket de Rheinmetall. C'est l'un des premiers fournisseurs de composants de moteurs pour le marché indépendant des pièces de rechange. Avec les marques haut de gamme Kolbenschmidt, Pierburg, TRW Engine Components ainsi que les marques BF et turbo by Intec, Motorservice propose à ses clients commerçants et garagistes une gamme étendue et variée de très grande qualité.

**RHEINMETALL**
**DES TECHNOLOGIES AU SERVICE DE LA MOBILITÉ DE DEMAIN**

Équipementier automobile présent dans le monde entier, Rheinmetall se place, grâce à son savoir-faire dans les domaines de l'alimentation en air, de la réduction des émissions nocives et des pompes ainsi que dans le développement, la fabrication et la fourniture de pistons, de blocs-moteurs et de coussinets, en tête de ces marchés respectifs. Le développement des produits se déroule en étroite coopération avec des constructeurs automobiles renommés.

# TRANSFERT DE SAVOIR-FAIRE LA COMPÉTENCE D'UN EXPERT

## FORMATIONS DANS LE MONDE ENTIER

### En direct du fabricant

Tous les ans, environ 4 500 mécaniciens et techniciens profitent de nos formations et des séminaires que nous organisons sur place, dans le monde entier, ou dans nos centres de formation de Neuenstadt, Dormagen et Tamm (Allemagne).

## INFORMATIONS TECHNIQUES

### Des informations issues de la pratique pour la pratique

Avec nos Product Information, Service Information, brochures techniques et posters, vous êtes à chaque instant à la pointe de la technique.

## VIDÉOS TECHNIQUES

### Transmission des connaissances par vidéo

Dans nos vidéos, vous trouverez des instructions de montage pratiques et des explications système concernant nos produits.



## PLEINS FEUX SUR LES PRODUITS EN LIGNE

### Nos solutions clairement expliquées

Au travers d'éléments interactifs, d'animations et de clips vidéo, apprenez tout ce qu'il faut savoir sur nos produits pour le moteur.

## BOUTIQUE EN LIGNE

### Votre accès direct à nos produits

Commande 24 h sur 24. Contrôle rapide de la disponibilité. Recherche produits exhaustive par moteur, véhicule, dimensions, etc.

## NEWS

### Informations régulières par e-mail

Inscrivez-vous vite en ligne à notre newsletter gratuite pour recevoir régulièrement des informations sur les nouveaux produits, les publications techniques et de nombreux autres sujets.

## INFORMATIONS PERSONNALISÉES

### Spécialement pour nos clients

Par notre intermédiaire, vous profitez d'informations et de services complets sur notre large gamme de prestations tels que du matériel de promotion des ventes personnalisé, des aides à la vente, un support technique et bien d'autres choses encore.



## TECHNIPEDIA

### Informations techniques concernant le moteur

Avec Technipedia, nous vous offrons un accès à notre savoir-faire. Vous y trouverez les connaissances techniques de nos experts directement.

## L'APPLI MOTORSERVICE

### Un accès mobile à notre savoir-faire technique

Vous y trouverez rapidement et facilement les informations et les services les plus à jour relatifs à nos produits.

## MÉDIAS SOCIAUX

### Toujours à jour

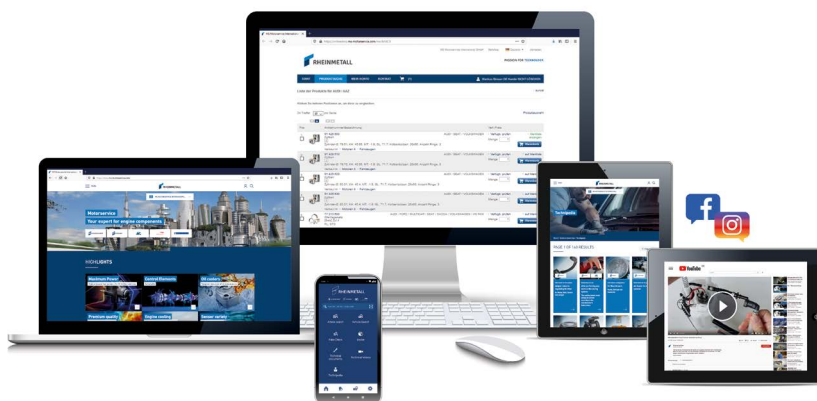

[www.ms-motorservice.com](http://www.ms-motorservice.com)







# 1. COMPOSANTS D'ACTIONNEMENT DES SOUPAPES ET CULASSES

## SOUPAPES

### Qualité et sécurité pour de nombreux kilomètres

Pendant une durée de service de 200 000 km, les soupapes subissent quelque 200 millions de changements de charge. Pour cette raison, les soupapes de TRW Engine Components sont conçues sur la base de méthodes de calcul modernes (FEA) et soumises à des contrôles complets avant la production en série.



## GUIDES SOUPAPE

### Guidage de haut niveau

Dans des conditions extrêmes, le guide soupape centre la soupape sur la bague de siège de soupape tout en évacuant une partie de la chaleur vers la culasse. Face à ces contraintes extrêmes, le matériau et ses propriétés sont des facteurs déterminants. Ne prenez aucun risque en misant sur la qualité des produits TRW Engine Components.



## BAGUES DE SIÈGE DE SOUPAPE

### À chaque application le matériau adapté

Les matériaux issus des procédés de coulée conventionnels ne suffisent plus pour faire face aux contraintes thermiques et mécaniques de plus en plus élevées auxquelles est exposée la bague de siège dans les moteurs modernes. C'est pourquoi Motorservice propose, parallèlement aux bagues de siège en fonte, des bagues de siège de soupape frittées composées de trois combinaisons de matériaux différentes.



## ARBRES À CAMES

### Des cames à l'épreuve de l'usure pour des moteurs puissants et durables

Les arbres à cames de la gamme Motorservice possèdent une capacité de résistance élevée afin de maîtriser sur une longue durée les contraintes de flexion et de torsion. Selon l'utilisation prévue, les arbres à cames sont coulés ou forgés.









## POUSOIRS HYDRAULIQUES

### Compensation automatique et sans entretien

Grâce à la conception des poussoirs hydrauliques, il n'est plus nécessaire de contrôler et d'ajuster le jeu, d'où une baisse considérable des frais d'entretien. Les poussoirs hydrauliques fonctionnent quasiment sans jeu, ce qui diminue l'usure liée au fonctionnement et agit également de manière positive sur la stabilité et le degré d'efficacité des moteurs.



## ÉLÉMENTS DE COMMANDE

### Une liaison solide

Des éléments de commande de grande qualité sont indispensables pour réaliser une transmission de force fiable et précise entre l'arbre à cames et la culasse. Les éléments de commande Motorservice garantissent la précision et la longévité de l'ensemble de la commande de soupapes.



## CULASSES

### Complétées en fonction de vos besoins

Motorservice dispose d'une gamme sélectionnée de culasses pour voitures particulières et véhicules utilitaires. Afin de répondre aux besoins et de faciliter les réparations, les culasses sont également disponibles équipées d'origine des soupapes et des ressorts de soupape.



**Vous trouverez des informations techniques sur les produits, le montage et le rodage sous:**  
[www.ms-motorservice.com](http://www.ms-motorservice.com)





## 2. PRÉCISIONS SUR L'UTILISATION DU CATALOGUE

### INDEX DES MOTEURS



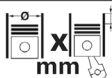



Une aide à la recherche détaillée figure au début de chaque section consacrée à un constructeur. Les désignations des moteurs sont classées en ordre alphanumérique.

KOLBENSCHMIDT		DEUTZ								
INDEX										
		Cyl.		mm	cm <sup>3</sup>	Comp. Ratio $\epsilon$	kW	PS	Pos	
A 6 M 816	D (AN)	6		142 x 160	15204	2	16:1	145-172	197-234	45
A 6 M 816 R	D (LA)	6		142 x 160	15204	2	16:1			45
A 6 M 816 U	D (LA)	6		142 x 160	15204	2	16:1			45
A 6 M 816 W	D (LA)	6		142 x 160	15204	2	16:1			45

Moteur N° de position

### Index des véhicules

Une aide à la recherche détaillée figure au début de chaque section consacrée à un constructeur. Les véhicules sont classés en ordre alphanumérique suivant catégorie de véhicule.

KOLBENSCHMIDT		AUDI					
INDEX							
 		Pos	 		Pos		
A1 (8X)			A4 1.8i Turbo 20V	01.1999 → 06.2000	ANB	B	23
1.4 TFSI 05.2010 →	CAXA	B	A4 1.8i Turbo 20V	06.2000 → 09.2001	AWT	B	27
2.0 TDI 09.2011 →	CFHB	D	A4 1.9 TDI	01.1995 → 07.1996	1Z	D	11
A2 (8Z)			A4 1.9 TDI	03.1996 → 07.1999	AFN	D	11

Véhicule / série de modèles N° de position

LIGNE CONSACRÉE AU MOTEUR

N° de position (numérotation continue pour chaque constructeur)		Année de construction de → à		Familles de pistons pour les moteurs indiqués. Pour les détails d'utilisation, voir le catalogue sur les pistons.			Taux de compression	
Ø nominal des cylindres		Type d'alimentation du moteur*					Course	
24	115	Cyl. 6		93 152 6..., 91 151 6...				
D 5TC EURO 1		03.1988 -> 04.1994		D [AN]	6	7800 cm3	2V	178 KW (242 PS)
(1) Conrod length = 220 mm		mot. -> 456789					16:1	125 mm
PL	St/A	50,000	53,708	29,00	1,822	STD	4	77 099 608
Observations	Numéro du moteur / numéro de série		Nombre de cylindres		Cylindrée		Renvoi à des observations	
Désignation du moteur avec type de catalyseur / catégorie de pollution		Type de carburant*		Nombre de soupapes		Puissance de → à		

\* voir liste des abréviations

**DONNÉES SUR LES PRODUITS**

Les pages du catalogue sont composées des blocs d'information représentés ci-après :

**FRANÇAIS**

**Demi-cônes**
**Champ consacré au constructeur**

<b>N° de position</b>	<b>Ligne consacrée aux pictogrammes</b>	<b>Ligne consacrée au moteur</b>	<b>Soupapes</b>													
		<div style="border: 1px solid black; padding: 5px; display: inline-block;">Constructeur</div>														
<div style="display: flex; justify-content: space-around; align-items: center;"> </div>																
<b>24</b> <b>115 Cyl. 6</b>																
<b>D 5TC EURO 1 03.1988 -&gt; 04.1994 D [AN] 6 7800 cm3 2V 178 kW (242 PS) 16:1 125 mm</b> <small>[1] Conrod length = 220 mm mot. -&gt; 456789 94 347 6. [1]</small>																
	IN [2] 39 x 7,9 x 114,3 M+0,8 EX [2] 33,4 x 7,9 x 114,3 S+0,15	I - C - Na - 44,5° - Y - 22 - V RA - C - - 44,5° - Y - 18 - III	105-35470 105-03364													
	[50] 8		12345678 KK-8													
	IN/EX [4] 12,06/15,2x7,98 x36,5	B1	056 103 419A 81-3310													
	IN/EX [4] 45,08 / 37 x 8,3	T 45°	352 053 16 31 352 053 22 31 50 004 885													
	491	AS/ES/L/R	028 109 101E 50 006 204													
	TAP [8] H 21,4 x 68 x 28		6 40 051 6 40 059 90295215 50 006 457													
	[4]		059 109 444 50 006 410													
	<p style="text-align: center;">- - G - S - PC - SB -</p> <div style="display: flex; align-items: center;"> <div style="margin-left: 10px;"> <table border="1" style="border-collapse: collapse; text-align: center;"> <tr><td>9</td><td>5</td><td>3</td><td>1</td><td>7</td><td>11</td></tr> <tr><td>12</td><td>8</td><td>2</td><td>4</td><td>6</td><td>10</td></tr> </table> <p>35 Nm 60 Nm 2 x 90° 90° warm/ chaud/calinte</p> </div> </div> <p style="text-align: center;">CAM - V - G - S - PC - SB - CB ready to install</p> <p style="font-size: small;">mot. 770.001-&gt;</p> <p style="font-size: x-small;">[1] Hydrosößel/Vorkammerbohrung Ø 32 mm hydraulic lifter/prechamber bore dia. 32 mm pussoirs hydrauliques/alésages pur la pré-chambre dia. 32 mm empuñadores hidráulicos/précamaras perforación dia. 32 mm</p>		9	5	3	1	7	11	12	8	2	4	6	10	074 103 351A 074 103 265DV	50 003 101 [1] 50 003 401 [1]
9	5	3	1	7	11											
12	8	2	4	6	10											

**Bagues de siège de soupape**
**Observations**
**Culasse**
**Poussoirs**

**Guides soupape**
**Culbuteurs**
**Arbres à cames**

\*voir liste des abréviations

SOUPAPES

<b>Soupape d'admission</b>	<b>Épaisseur du bord majorée (mm)</b>	<b>Matériau du noyau de la soupape*</b>	<b>Numéro de référence</b>
<b>Unité d'emballage</b>	<b>Ø tête × Ø tige × longueur (mm)</b>	<b>Traitement du siège de soupape*</b>	<b>N° d'article soupape</b>
IN [2]	39 x 7,9 x 114,3 M+0,8	I - C - Na - 44,5° - Y - 22 - V	105-35470
EX [2]	33,4 x 7,9 x 114,3 S+0,15	RA - C - - 44,5° - Y - 18 - III	105-03364
<b>Soupape d'échappement</b>	<b>Matériau</b>	<b>Angle du siège de soupape</b>	<b>Traitement queue de la soupape*</b>
<b>Surcote de la tige (mm)</b>	<b>Traitement de la face de queue de soupape*</b>	<b>Modèle de queue de soupape*</b>	

DEMI-CÔNES

<b>Unité d'emballage</b>	<b>N° d'article demi-cônes</b>
[50]	12345678
8	KK-8
<b>Ø extérieur (mm)</b>	<b>Numéro de référence</b>

GUIDES SOUPAPE

<b>Guide de soupape d'admission</b>	<b>Unité d'emballage</b>	<b>Matériau*</b>	<b>Numéro de référence</b>
<b>Guide de soupape d'échappement</b>	<b>Ø extérieur / Ø collerette × Ø intérieur × longueur (mm)</b>	<b>N° d'article guide soupape</b>	
IN EX [4]	12,06/15,2 x 7,98 x 36,5	B1	056 103 419A
			81-3310

FRANÇAIS

\*voir liste des abréviations



**BAGUES DE SIÈGE DE SOUPE**

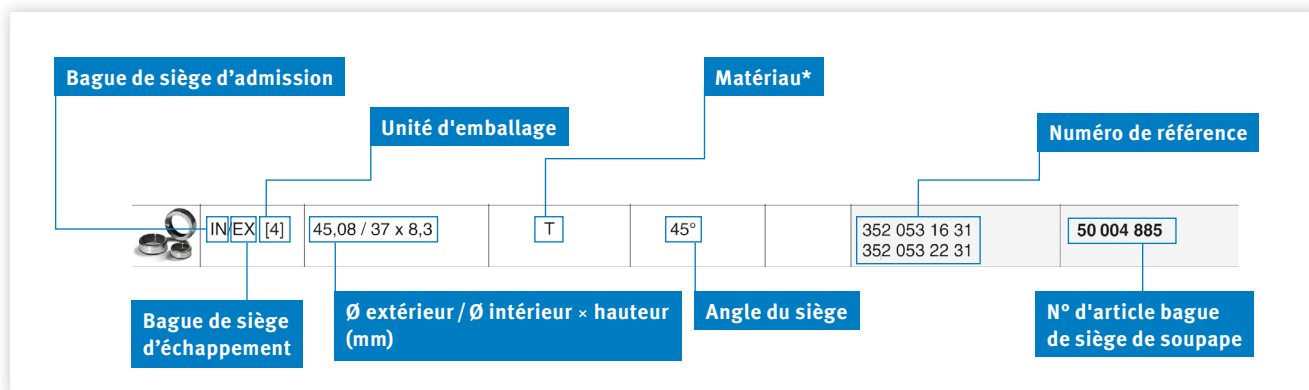

**ARBRES À CAMES**

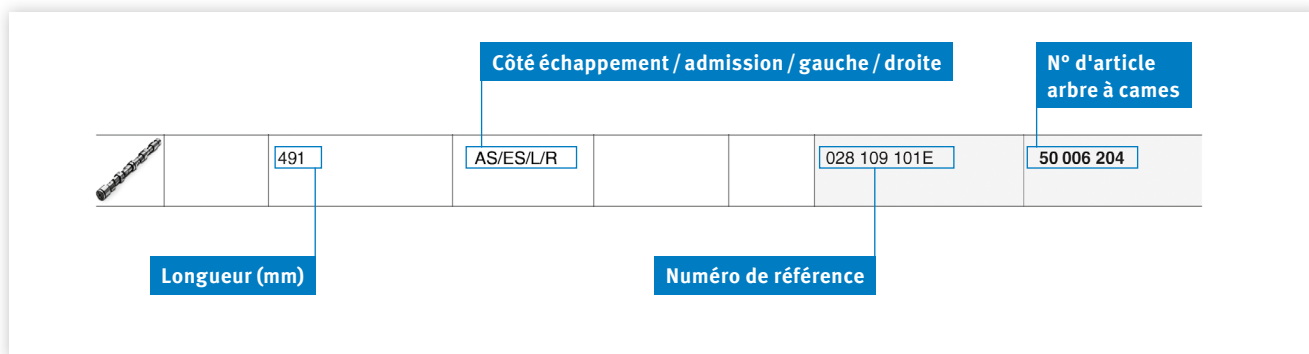

**POUSSOIRS**



FRANÇAIS

CULBUTEURS

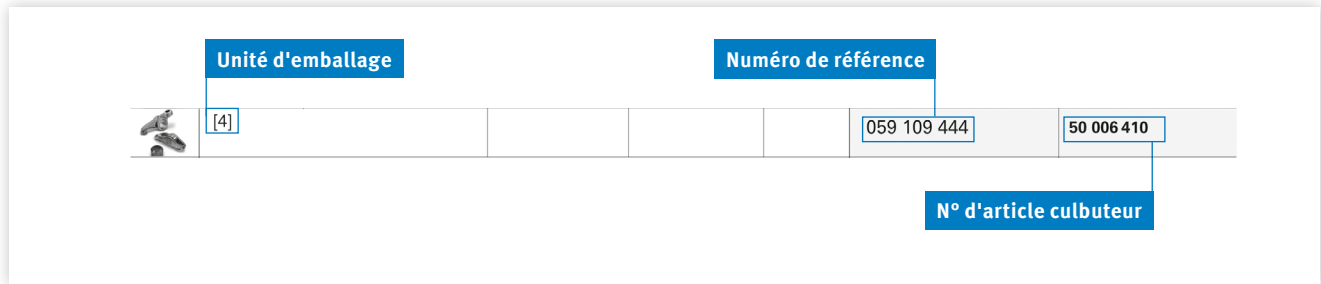

CULASSE

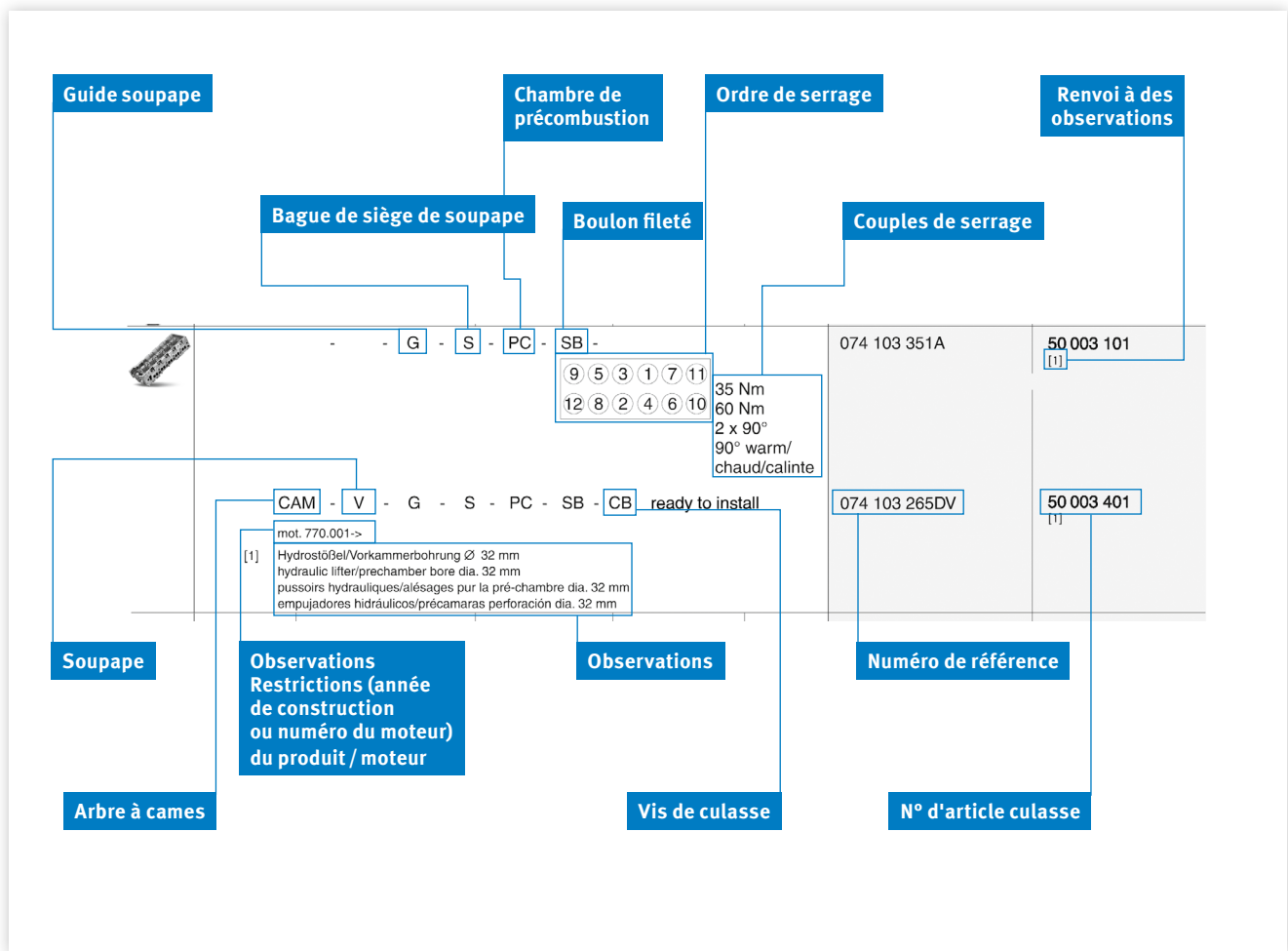

FRANÇAIS

### 3. DEMI-CÔNES – MODÈLES ET DIMENSIONS

Matériau	Description	Modèle	Ø tige de soupape	Trempé par cémentation	Nombre de rainures
KK-6H	demi-cône à une rainure	liaison serrante	6	trempé	1
KK-7H	demi-cône à une rainure	liaison serrante	7	trempé	1
KK-8H	demi-cône à une rainure	liaison serrante	8	trempé	1
KK-9H	demi-cône à une rainure	liaison serrante	9	trempé	1
KK-10H	demi-cône à une rainure	liaison serrante	10	trempé	1
KK-11H	demi-cône à une rainure	liaison serrante	10	trempé	1
KK-12H	demi-cône à une rainure	liaison serrante	12	trempé	1
LK-5H	demi-cône à une rainure	liaison serrante	5	trempé	1
LK-5.5H	demi-cône à une rainure	liaison serrante	5,5	trempé	1
LK-6H	demi-cône à une rainure	liaison serrante	6	trempé	1
LK-7H	demi-cône à une rainure	liaison serrante	7	trempé	1
LK-1610	demi-cône à une rainure	liaison serrante	12	non trempé	1
LK-2607	demi-cône à une rainure	liaison serrante	7	trempé	1
LK-2615	demi-cône à une rainure	liaison serrante	9	non trempé	1
MK-5H	demi-cône à rainures multiples	liaison non serrante	5	trempé	3
MK-5.5H	demi-cône à rainures multiples	liaison non serrante	5,5	trempé	3
MK-6H	demi-cône à rainures multiples	liaison non serrante	6	trempé	3
MK-7H	demi-cône à rainures multiples	liaison non serrante	7	trempé	3
MK-7H2	demi-cône à rainures multiples	liaison non serrante	7	trempé	2
MK-8H	demi-cône à rainures multiples	liaison non serrante	8	trempé	3
MK-9H	demi-cône à rainures multiples	liaison non serrante	9	trempé	3
MK-10H	demi-cône à rainures multiples	liaison non serrante	10	trempé	4
MK-12H	demi-cône à rainures multiples	liaison non serrante	12	trempé	4
RK-7	demi-cône à une rainure	liaison serrante	7	non trempé	1
RK-7H	demi-cône à une rainure	liaison serrante	7	trempé	1
RK-8	demi-cône à une rainure	liaison serrante	8	non trempé	1
RK-8H	demi-cône à une rainure	liaison serrante	8	trempé	1
RK-9H	demi-cône à une rainure	liaison serrante	9	trempé	1
RK-10H	demi-cône à une rainure	liaison serrante	10	trempé	1
RK-11H	demi-cône à une rainure	liaison serrante	11	trempé	1
RK-9.5H	demi-cône à une rainure	liaison serrante	9,5	trempé	1

#### Demi-cônes à rainure KK

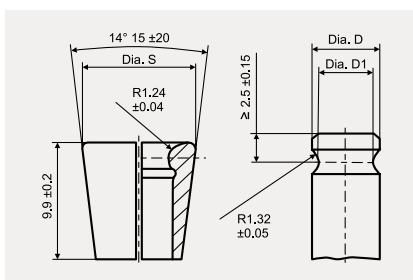

Demi-cônes à rainure KK, cône 1:4

Abréviation		Dimensions de la queue de la soupape					Poids (g)
Non trempé	Trempé par cémentation	Ø S ± 0.06	Ø D dimension nominale	Plage préférentielle Ø D			
				de	à	Ø D1	
KK 6	KK 6H	10	6	5.99	5.89	4.85 ± 0.05	1.17
KK 7	KK 7H	11	7	6.99	6.89	5.85 ± 0.05	1.37
KK 8	KK 8H	12	8	7.99	7.89	6.83 ± 0.07	1.55
KK 9	KK 9H	13	9	8.99	8.89	7.8 ± 0.1	1.73
KK 10	KK 10H	14	10	9.99	9.89	8.8 ± 0.1	1.90
KK 11	KK 11H	15	11	10.99	10.89	9.8 ± 0.1	2.00
KK 12	KK 12H	16	12	11.99	11.89	10.8 ± 0.1	2.24

**Demi-cônes à rainure LK**

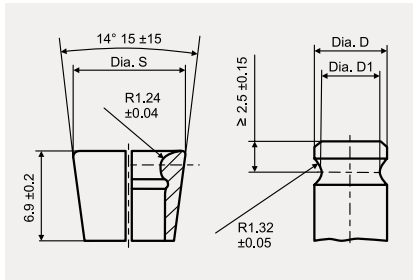

Demi-cônes à rainure LK, cône 1:4

Abréviation		Dimensions de la queue de la soupape					
Non trempé	Trepné par cémentation	Ø S ± 0.06	Ø D dimension nominale	Plage préférentielle Ø D			Poids (g)
				de	à	Ø D1	
LK 5.5	LK 5.5H	8.5	5.5	5.49	5.39	4.35 ± 0.05	0.58
LK 6	LK 6H	9	6	5.99	5.89	4.85 ± 0.05	0.64
LK 6.5	LK 6.5H	9.5	6.5	6.49	6.39	5.35 ± 0.05	0.69
LK 7	LK 7H	10	7	6.99	6.89	5.85 ± 0.05	0.73

**Demi-cônes à rainure RK**

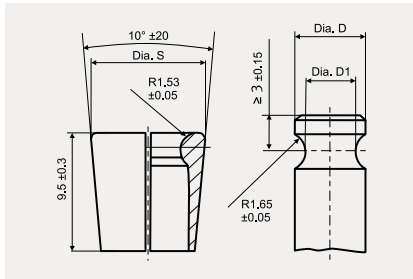

Demi-cônes à rainure RK, cône 1:4

Abréviation		Dimensions de la queue de la soupape					
Non trempé	Trepné par cémentation	Ø S ± 0.06	Ø D dimension nominale	Plage préférentielle Ø D			Poids (g)
				de	à	Ø D1	
RK 6	RK 6H	8.79	6	5.99	5.89	4.15 ± 0.05	0.77
RK 7	RK 7H	9.79	7	6.99	6.89	5.15 ± 0.05	0.91
RK 8	RK 8H	10.79	8	7.99	7.89	6.13 ± 0.07	1.09
RK 9	RK 9H	11.79	9	8.99	8.89	7.1 ± 0.1	1.19
RK 10	RK 10H	12.79	10	9.99	9.89	8.1 ± 0.1	1.30
RK 11	RK 11H	13.79	11	10.99	10.89	9.1 ± 0.1	1.46
RK 12	RK 12H	14.79	12	11.99	11.89	10.1 ± 0.1	1.58

**Demi-cône à rainures multiples MK 5-6**

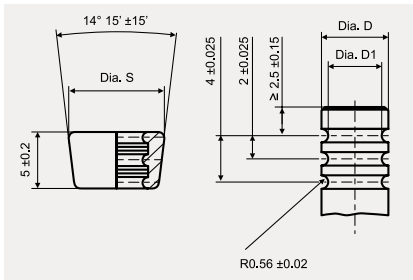

Demi-cône à rainures multiples MK 5-6, cône 1:4

Type	Nombre de bourrelets	Ø D ± 0.02	Ø D1	Ø S ± 0.05	Poids (g)
MK 5	3	4.92	3.91 ± 0.05	7.0	0.30
MK 5.5	3	5.42	4.41 ± 0.05	7.5	0.35
MK 6	3	5.92	4.59 ± 0.05	8.5	0.49
MK 7	3	6.92	5.25 ± 0.05	10.5	1.12
MK 8	3	7.92	6.23 ± 0.07	11.5	1.27
MK 9	3	8.92	7.20 ± 0.1	12.5	1.40

**Demi-cône à rainures multiples MK 10-12**

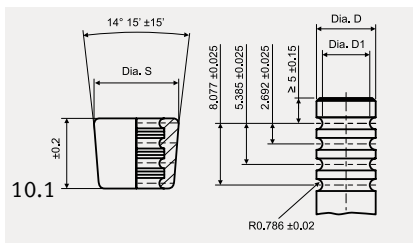

Demi-cône à rainures multiples MK 10-12, cône 1:4

Type	Nombre de bourrelets	Ø D ± 0.02	Ø D1	Ø S ± 0.05	Poids (g)
MK 10	4	9.92	8.20 ± 0.1	13.8	2.04
MK 11	4	10.92	9.20 ± 0.1	14.8	2.19
MK 12	4	11.92	10.20 ± 0.1	15.8	2.82



## 4. Bagues de siège de soupape – Recommandations d'application et instructions de montage

### RÉCAPITULATIF

	HM (High Machinability)	HT (High Temperature Resistance)	HT+ (High Temperature Resistance)	G1 (High Temperature Resistance)	G2 (Highly wear-resistant)
Type de carburant / combustion	essence (sans plomb), gazole	essence (sans plomb), gazole	essence (sans plomb), gazole, GNV, GPL, propane, Flex Fuel	essence (sans plomb), gazole	GNV, GPL, Flex Fuel, essence (sans plomb), gazole
Matériaux de la culasse	aluminium, fonte grise	aluminium, fonte grise	aluminium, fonte grise	aluminium, fonte grise	aluminium, fonte grise
Moteurs	moteurs essence et diesel peu puissants à contrainte faible à normale	moteurs essence et diesel puissants, fortement suralimentés et à contraintes élevées	moteurs à gaz tels que GPL, GNV, propane, Flex Fuel ; moteurs essence et diesel puissants	moteurs atmosphériques, moteurs suralimentés	moteurs à puissance accrue, à contrainte élevée, tous les moteurs à gaz ci-dessus

#### ATTENTION

Les conditions d'exploitation extrêmes et les contraintes élevées du moteur considéré doivent être prises en compte et relèvent de la responsabilité du rectifieur.

#### REMARQUE

Le remplacement de bagues de siège de soupape et de soupapes dans le cas d'une transformation pour fonctionnement au gaz représente toujours une intervention dans les spécifications d'origine du moteur. En amont, seule une estimation de l'harmonie des nouveaux couplages de matériaux et des résultats escomptés dans les conditions modifiées est possible. Les conditions d'exploitation extrêmes et les contraintes spécifiques du moteur doivent être prises en compte. Ceci relève de la seule responsabilité du rectifieur de moteurs.

### KOLBENSCHMIDT / TRW ENGINE COMPONENTS RECOMMANDE LES RECOUVREMENTS / AJUSTAGES SERRÉS SUIVANTS

Diamètre extérieur bague de siège		Culasse en fonte		Culasse en aluminium	
[mm]	[pouce]	[mm]	[pouce]	[mm]	[pouce]
20 – 30	0.7874 – 1.1811	0,06	0.0024	0,08	0.0031
30 – 40	1.1811 – 1.5748	0,08	0.0031	0,10	0.0040
40 – 50	1.5748 – 1.9685	0,10	0.0040	0,12	0.0047
50 – 60	1.9685 – 2.3622	0,12	0.0047	0,14	0.0055
60 – 70	2.3622 – 2.7559	0,14	0.0055	0,16	0.0063

Afin que la gamme proposée soit toujours complète, de nouveaux types viennent régulièrement compléter notre assortiment. Renseignez-vous auprès de votre correspondant. Il vous fournira les informations les plus récentes. Les matériaux qui composent les soupapes et les guides soupape sont adaptés aux bagues de siège et garantissent un fonctionnement optimal.

#### Instruction de commande

Si vous avez besoin d'une dimension spéciale, qui ne figure pas dans la liste, parlez-en à votre correspondant. Toute dimension non indiquée peut être fabriquée sur demande dans un délai de 14 semaines.



**INDICACIONES IMPORTANTES**

Todos los datos de este catálogo no son vinculantes. No podemos asumir ninguna responsabilidad por su exactitud e integridad. La información sobre posibles errores en el catálogo es siempre bienvenida y será corregida en futuras ediciones.

Los nombres, descripciones y números de vehículos o fabricantes, entre otros, así como los números de pieza originales de los fabricantes de vehículos y motores, solo se indican con fines comparativos. Las indicaciones correspondientes no son denominaciones de origen y no pueden utilizarse con terceros. Tenga también en cuenta que no se pueden descartar modificaciones en el equipamiento por parte de los fabricantes de vehículos o motores, ni cambios en las denominaciones. Por lo tanto, no podemos asumir ninguna responsabilidad por el uso de las listas comparativas.

Nos reservamos expresamente el derecho de modificar en cualquier momento las especificaciones del producto, los materiales, el aspecto y el volumen de suministro de nuestros productos. Por lo tanto, las ilustraciones del catálogo no son vinculantes.

Antes del montaje, se debe comprobar siempre si el producto adquirido es adecuado para el uso previsto. De nuestra información no se puede derivar una afirmación sobre una determinada naturaleza o idoneidad para un uso determinado. En particular, hay que tener en cuenta que los productos ofrecidos en el catálogo no están destinados a ser utilizados en aeronaves o naves espaciales. Cuando se utilizan en motores fuera de carretera (p. ej. motores marinos, estacionarios o subterráneos) se debe tener en cuenta que, con la misma denominación del motor, pueden utilizarse diferentes piezas del motor (p. ej. pistones). En caso necesario, se debe solicitar el asesoramiento del fabricante o del taller autorizado antes de instalar los productos. Además, le informamos de que el montaje debe ser realizado siempre por personal técnico con formación. Las ilustraciones, los esquemas y demás indicaciones se muestran con fines explicativos e ilustrativos y no pueden utilizarse como base para la instalación.

Cualquier duplicación, imitación, distribución o reproducción pública de este catálogo, incluso parcial, solo está permitida con nuestro consentimiento previo por escrito y la correspondiente referencia a la fuente. Con la publicación de este catálogo, todas las ediciones anteriores pierden su validez.

**CERTIFICACIONES**

MS Motorservice International GmbH cuenta con un sistema de gestión de calidad certificado según ISO 9001 y un sistema de gestión medioambiental certificado según ISO 14001.





LOS CONTENIDOS DEL CATÁLOGO TAMBIÉN SE RECOGEN EN NUESTRO CATÁLOGO ONLINE, EN NUESTRA APLICACIÓN, ASÍ COMO EN TECALLIANCE.

**Más información:**  
[catalog.ms-motorservice.com](http://catalog.ms-motorservice.com)  
[motorservice.app](http://motorservice.app)

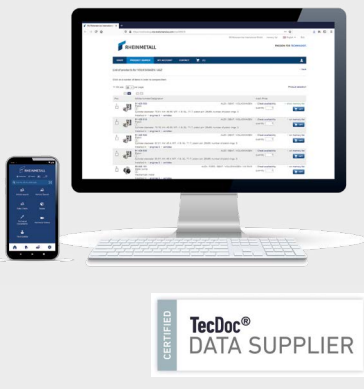
**ÍNDICE**
**PÁGINA**

	Nota importante	56
	Gestión de calidad	56
	Transferencia de conocimientos especiales: conocimientos técnicos del experto	58
1.	Componentes del mecanismo de distribución por válvulas y culatas de cilindros	61
<b>2.</b>	<b>INDICACIONES PARA LA UTILIZACIÓN DEL CATÁLOGO</b>	<b>64</b>
3.	Chavetas de sujeción de válvula: ejecuciones y dimensiones	70
4.	Recomendaciones de uso e indicaciones para el montaje	72
5.	Listas de dimensiones de insertos para asientos de válvulas	109
5.1	Ordenado por diámetro exterior D (mm)	110
5.2	Ordenado por diámetro exterior D (in)	117
6.	Adición al programa	123
7.	Índice de fabricantes	139
<b>8.</b>	<b>PROGRAMA DE PRODUCTOS</b>	<b>141</b>
9.	N.º de Kolbenschmidt / BF / TRW Engine Components: utilización	1419
10.	Lista de referencias	1457
11.	Manera de proceder en caso de reclamación / formulario de reclamación	

**GRUPO MOTORSERVICE**
**CALIDAD Y SERVICIO EN UN SOLO PROVEEDOR**

El Grupo Motorservice es la organización de ventas y distribución para las actividades de servicio posventa de Rheinmetall en todo el mundo. Se trata de uno de los principales proveedores de componentes del motor en el mercado libre de piezas de repuesto. Gracias a las marcas de primera calidad Kolbenschmidt, Pierburg y TRW Engine Components, así como a las marcas BF y turbo by Intec, Motorservice ofrece a sus clientes comerciales y de talleres un amplio y completo surtido de máxima calidad.

**RHEINMETALL**
**TECNOLOGÍAS PARA LA MOVILIDAD DEL FUTURO**

Como proveedor automotriz internacional, Rheinmetall está a la cabeza en los mercados correspondientes gracias a su gran competencia en los sectores de alimentación de aire, reducción de contaminantes y bombas, así como en el desarrollo, producción y suministro de piezas de repuesto para pistones, bloques de motor y cojinetes de fricción. El desarrollo de productos se efectúa en estrecha colaboración con fabricantes de automóviles de renombre.



# TRANSFERENCIA DE EXPERIENCIAS CONOCIMIENTOS TÉCNICOS DEL EXPERTO

## CURSOS FORMATIVOS EN TODO EL MUNDO

### Directamente del fabricante

Aualmente, alrededor de 4.500 mecánicos y técnicos se benefician de nuestros cursos formativos y seminarios, que realizamos a escala mundial in situ o también en nuestros centros de formación en Neuenstadt y Dormagen y Tamm (Alemania).

## INFORMACIONES TÉCNICAS

### De la práctica para la práctica

Con las Product Information, las Service Information, los folletos técnicos y los pósters, estará usted siempre a la vanguardia de la técnica.

## VÍDEOS TÉCNICOS

### Difusión de conocimientos por vídeo

En nuestros vídeos encontrará indicaciones prácticas para el montaje y aclaraciones sistemáticas sobre nuestros productos.



## PRODUCTOS EN EL PUNTO DE MIRA ONLINE

### Nuestras soluciones explicadas de forma gráfica

Conozca, gracias a los elementos interactivos, las animaciones y los clips de vídeo, aspectos curiosos de nuestros productos para y acerca del motor.

## TIENDA ONLINE

### Su acceso directo a nuestros productos

Realice pedidos las 24 horas. Rápida comprobación de la disponibilidad. Amplia búsqueda de productos del motor, el vehículo, las dimensiones, etc.

## NOVEDADES

### Informaciones regulares por e-mail

Suscríbase de forma online a nuestro Newsletter gratuito y recibirá periódicamente informaciones sobre productos recién incluidos, publicaciones técnicas y mucho más.

## INFORMACIONES INDIVIDUALES

### Especialmente para nuestros clientes

Le ofrecemos numerosas informaciones y servicios sobre nuestro amplio espectro de prestaciones: como por ejemplo, materiales de promoción de ventas personalizados, asistencias de ventas, soporte técnico y mucho más.



## TECNIPEDIA

### Informaciones técnicas en torno al motor

En nuestra Tecnipedia compartimos con usted nuestra experiencia. Aquí podrá encontrar conocimientos técnicos directamente del experto.

## APLICACIÓN DE MOTORSERVICE

### Acceso móvil a la experiencia técnica

Aquí podrá obtener de forma rápida y sencilla las informaciones y los servicios más actuales acerca de nuestros productos.

## MEDIOS SOCIALES

### Siempre actual



[www.ms-motorservice.com](http://www.ms-motorservice.com)







ESPAÑOL

# 1. COMPONENTES DEL MECANISMO DE DISTRIBUCIÓN POR VÁLVULAS Y CULATAS DE CILINDROS

## VÁLVULAS

### Calidad y seguridad durante muchos kilómetros

Durante un tiempo de servicio de 200.000 km, las válvulas experimentan aproximadamente 200 millones de cambios de carga. Por este motivo, las válvulas TRW Engine Components se diseñan aplicando los métodos de cálculo más modernos (FEA) y se someten a numerosas comprobaciones antes de la fabricación en serie.



## GUÍAS DE VÁLVULA

### Un guiado de otro nivel

En condiciones extremas, la guía centra la válvula en el inserto para asiento de válvula, al mismo tiempo que cede una parte del calor a la culata. Tanto el material como sus propiedades constituyen un factor importante en estas cargas extremas: vaya sobre seguro y apueste por la calidad de los productos de TRW Engine Components.



## INSERTOS PARA ASIENTOS DE VÁLVULAS

### El material adecuado para cada uso

Los materiales procedentes de los métodos de fundición convencionales apenas podrían resistir los grandes esfuerzos térmicos y mecánicos a los que está sometido el inserto para asiento de válvula en los motores modernos. Por este motivo, Motorservice también ofrece, además de anillos de asiento de fundición, insertos para asiento de válvula sinterizados de tres combinaciones de materiales diferentes.



## ÁRBOLES DE LEVAS

### Levas resistentes al desgaste para una prolongada vida útil del motor con aumento de potencia

Para hacer frente a los elevados esfuerzos de flexión y torsión durante un período de tiempo prolongado, los árboles de levas del programa de suministro de Motorservice poseen una resistencia muy elevada. En función de la finalidad de uso, los árboles de levas pueden ser fundidos o forjados.









## TAQUÉ HIDRÁULICO

### Sin mantenimiento, compensación automática

Gracias a la construcción del taqué hidráulico se suprimen la comprobación necesaria y el reajuste del juego, lo que disminuye correspondientemente los costes de mantenimiento. Los taqués hidráulicos trabajan casi sin juego, lo que disminuye el desgaste debido al servicio y, además, influye de forma favorable en la suavidad de marcha y el grado de eficacia de los motores.



## ELEMENTOS DE CONTROL

### Conexión sólida

Una transmisión de fuerza fiable y exacta entre el árbol de levas y la culata solo puede llevarse a cabo con elementos de control de alta calidad. Los elementos de control de Motorservice garantizan la exactitud y la larga vida útil de todo el mando de la válvula.



## CULATAS DE CILINDROS

### Completadas para usted en función de sus necesidades

Motorservice dispone de una selecta gama de productos en culatas de cilindros para turismos y vehículos utilitarios. Adaptadas a las necesidades y fáciles de reparar, las culatas de cilindros también están disponibles con válvulas y resortes de válvula premontados.



Podrá encontrar información técnica sobre productos, el montaje y el rodaje en:  
[www.ms-motorservice.com](http://www.ms-motorservice.com)

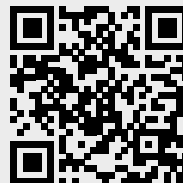

## 2. INDICACIONES PARA LA UTILIZACIÓN DEL CATÁLOGO

### ÍNDICE DE MOTORES

Al comienzo de cada sección dedicada a un fabricante encontrará una amplia ayuda para realizar búsquedas. Las denominaciones de los motores están clasificadas en orden alfanumérico ascendente.

KOLBENSCHMIDT									
INDEX									
		Cyl.	X mm	cm <sup>3</sup>		Comp. Ratio ε	kW	PS	Pos
A 6 M 816		D (AN) 6	142 x 160	15204	2	16:1	145-172	197-234	45
A 6 M 816 R		D (LA) 6	142 x 160	15204	2	16:1			45
A 6 M 816 U		D (LA) 6	142 x 160	15204	2	16:1			45
A 6 M 816 W		D (LA) 6	142 x 160	15204	2	16:1			45

**Motor** **N.º de posición**

### ÍNDICE DE VEHÍCULOS

Al comienzo de cada sección dedicada a un fabricante encontrará una amplia ayuda para realizar búsquedas. Los vehículos están clasificados en orden alfanumérico ascendente después de categoría de vehículos.

KOLBENSCHMIDT							
INDEX							
		Pos			Pos		
A1 (8X)			A4 1.8i Turbo 20V	01.1999 → 06.2000	ANB	B	23
1.4 TFSI 05.2010 →	CAXA	B 3	A4 1.8i Turbo 20V	06.2000 → 09.2001	AWT	B	27
2.0 TDI 09.2011 →	CFHB	D 33	A4 1.9 TDI	01.1995 → 07.1996	1Z	D	11
A2 (8Z)			A4 1.9 TDI	03.1996 → 07.1999	AFN	D	11

**Vehículo / serie de modelos** **N.º de posición**

LÍNEA PARA MOTORES

N.º de posición (numeración consecutiva por fabricante)		Año de construcción desde → hasta		Familias de pistones para los motores indicados. Para obtener detalles sobre la utilización, véase el catálogo de pistones.			Relación de compresión				
Ø nominal del cilindro		Tipo de alimentación*					Carrera				
24	115	Cyl. 6		93 152 6... 91 151 6..							
D 5TC EURO 1		03.1988 -> 04.1994		D [AN]	6	7800 cm3	2V	178 KW (242 PS)	16:1	125 mm	(1)
(1) Conrod length = 220 mm		mot. -> 456789									
PL	St/A	50,000	53,708	29,00	1,822	STD 0.30		4	77 099 608		
Observaciones		N.º de motor / n.º de serie		Cantidad de cilindros		Cilindrada		Referencia para observaciones			
Denominación del motor con tipo de catalizador / categoría de sustancias contaminantes		Tipo de combustible*		Cantidad de válvulas		Potencia desde → hasta					

\* Véase la lista de abreviaturas



**DATOS DE LOS PRODUCTOS**

Las páginas del catálogo se componen de bloques de información indicados a continuación:

Chavetas de sujeción de válvula		Casilla del fabricante			
N.º de posición	Línea con pictogramas	Línea para motores	Válvulas		
KOLBENSCHMIDT		TRW EngineComponents		Fabricante	
<b>24</b>	<b>115 Cyl. 6</b>				
<b>D 5TC EURO 1</b>	<b>03.1988 -&gt; 04.1994</b>	<b>D [AN]</b>	<b>6</b>	<b>7800 cm3</b>	<b>2V</b>
[1] Conrod length = 220 mm		mot. -> 456789		<b>178 kW (242 PS)</b>	<b>16:1</b>
94 347 6.				<b>125 mm</b>	[1]
	IN [2] 39 x 7,9 x 114,3 M+0,8	I - C - Na	- 44,5° - Y	- 22 - V	105-35470
	EX [2] 33,4 x 7,9 x 114,3 S+0,15	RA - C -	- 44,5° - Y	- 18 - III	105-03364
	[50] 8				12345678 KK-8
	IN/EX [4] 12,06/15,2x7,98 x36,5	B1			056 103 419A 81-3310
	IN/EX [4] 45,08 / 37 x 8,3	T	45°		352 053 16 31 352 053 22 31 50 004 885
	491	AS/ES/L/R			028 109 101E 50 006 204
	TAP [8] H 21,4 x 68 x 28				6 40 051 6 40 059 90295215 50 006 457
	[4]				059 109 444 50 006 410
	- - G - S - PC - SB -  CAM - V - G - S - PC - SB - CB ready to install mot. 770.001-> [1] Hydrosößel/Vorkammerbohrung Ø 32 mm hydraulic lifter/prechamber bore dia. 32 mm pousseurs hydrauliques/alésages pur la pré-chambre dia. 32 mm empuñadores hidráulicos/précamaras perforación dia. 32 mm	9 5 3 1 7 11 12 8 2 4 6 10 35 Nm 60 Nm 2 x 90° 90° warm/ chaud/caliente	074 103 351A	50 003 101 [1]	
				074 103 265DV	50 003 401 [1]
<b>Insertos para asientos de válvulas</b>	<b>Observaciones</b>	<b>Culata</b>	<b>Taqués</b>	<b>Árboles de levas</b>	<b>Balancín y palanca de arrastre</b>
<b>Guías de válvula</b>					

\*Véase la lista de abreviaturas

ESPAÑOL

VÁLVULAS

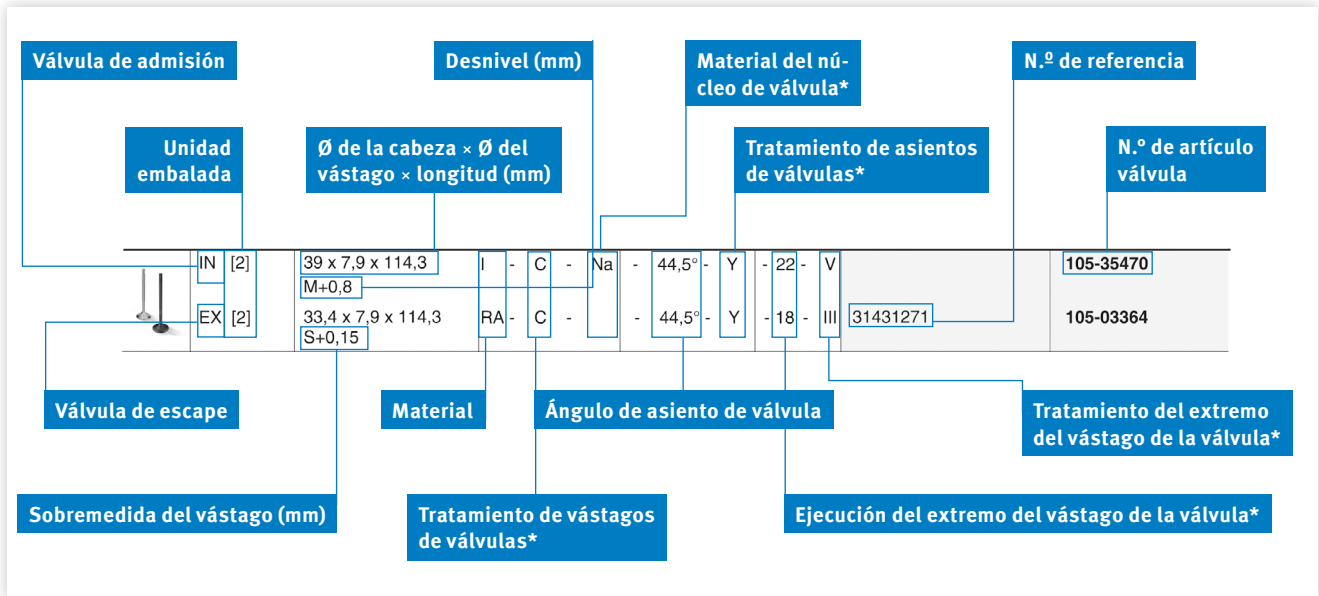

CHAVETAS DE SUJECIÓN DE VÁLVULA

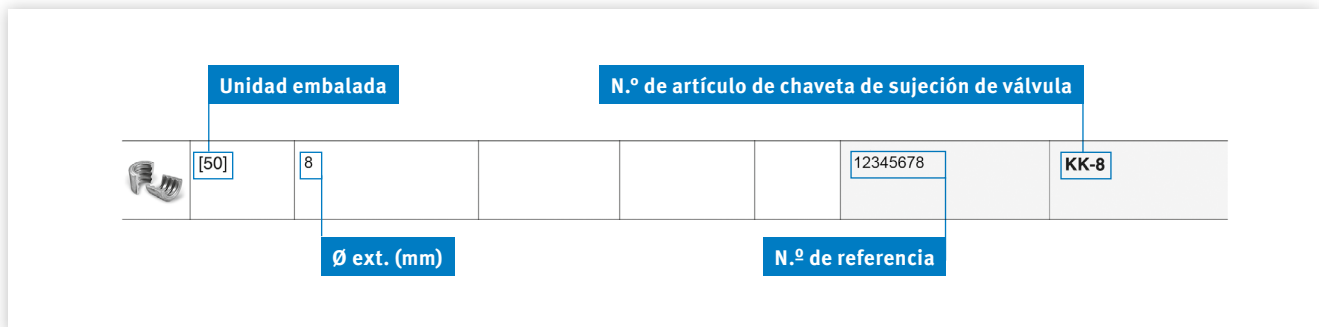

GUÍAS DE VÁLVULA

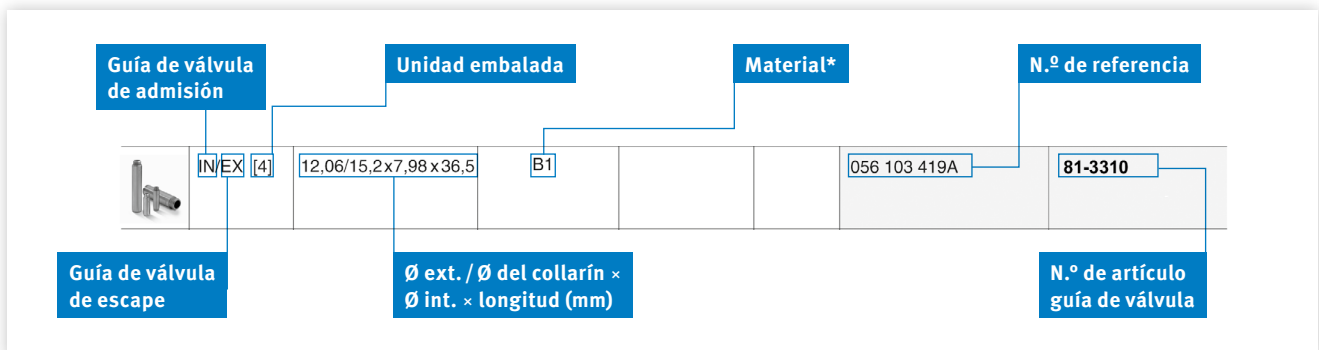

\*Véase la lista de abreviaturas

**INSERTOS PARA ASIENTOS DE VÁLVULAS**

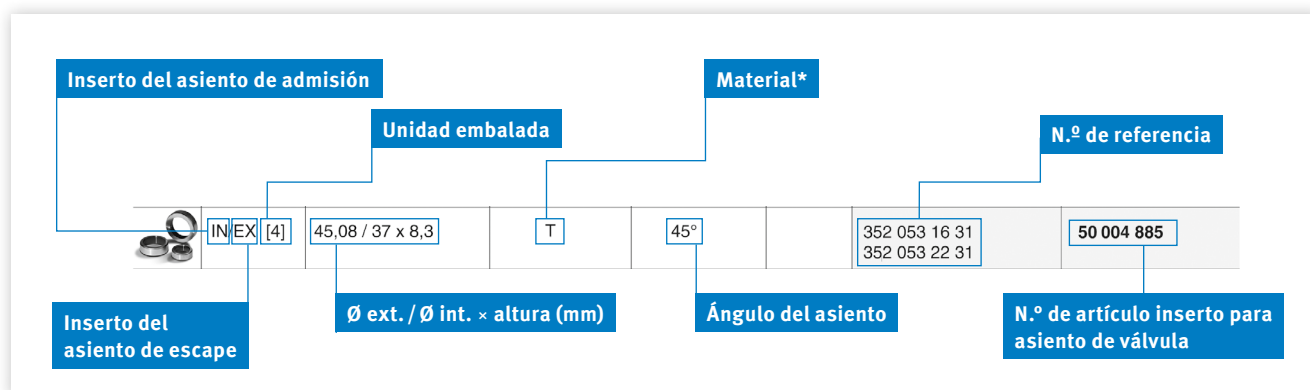

**ÁRBOLES DE LEVAS**

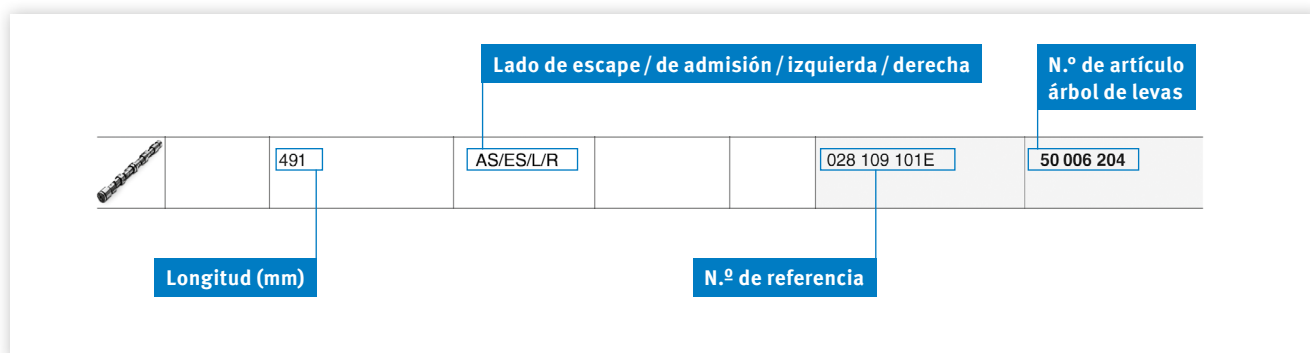

**TAQUÉS**

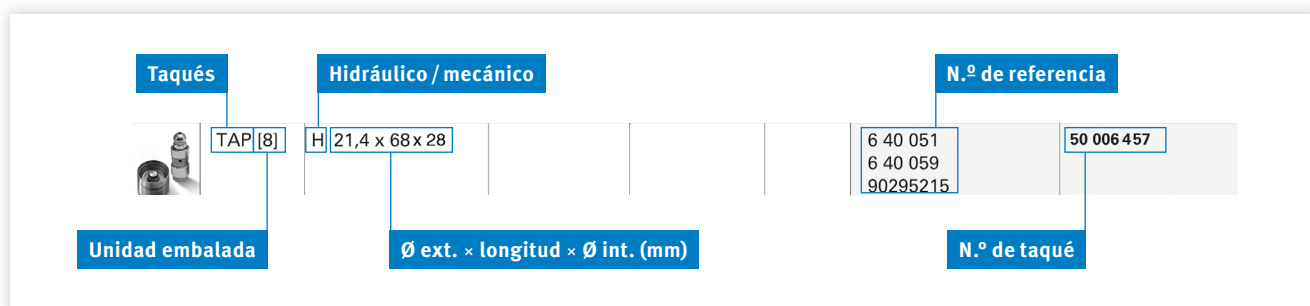

ESPAÑOL

**BALANCÍN Y PALANCA DE ARRASTRE**

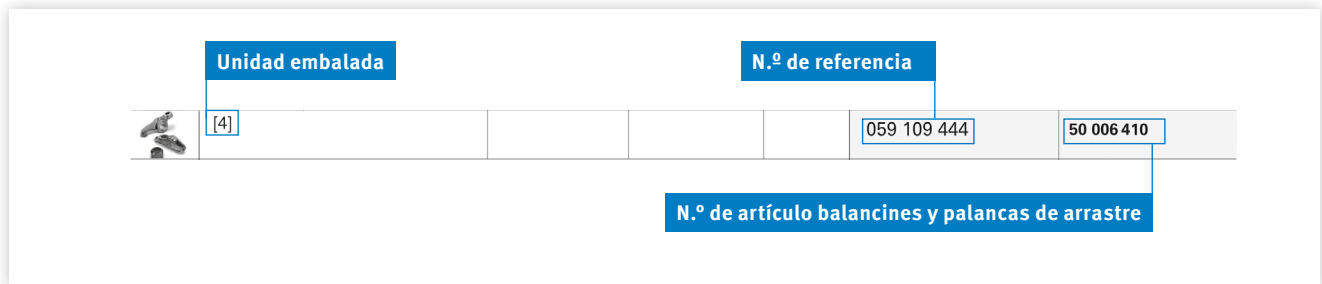

**CULATA**

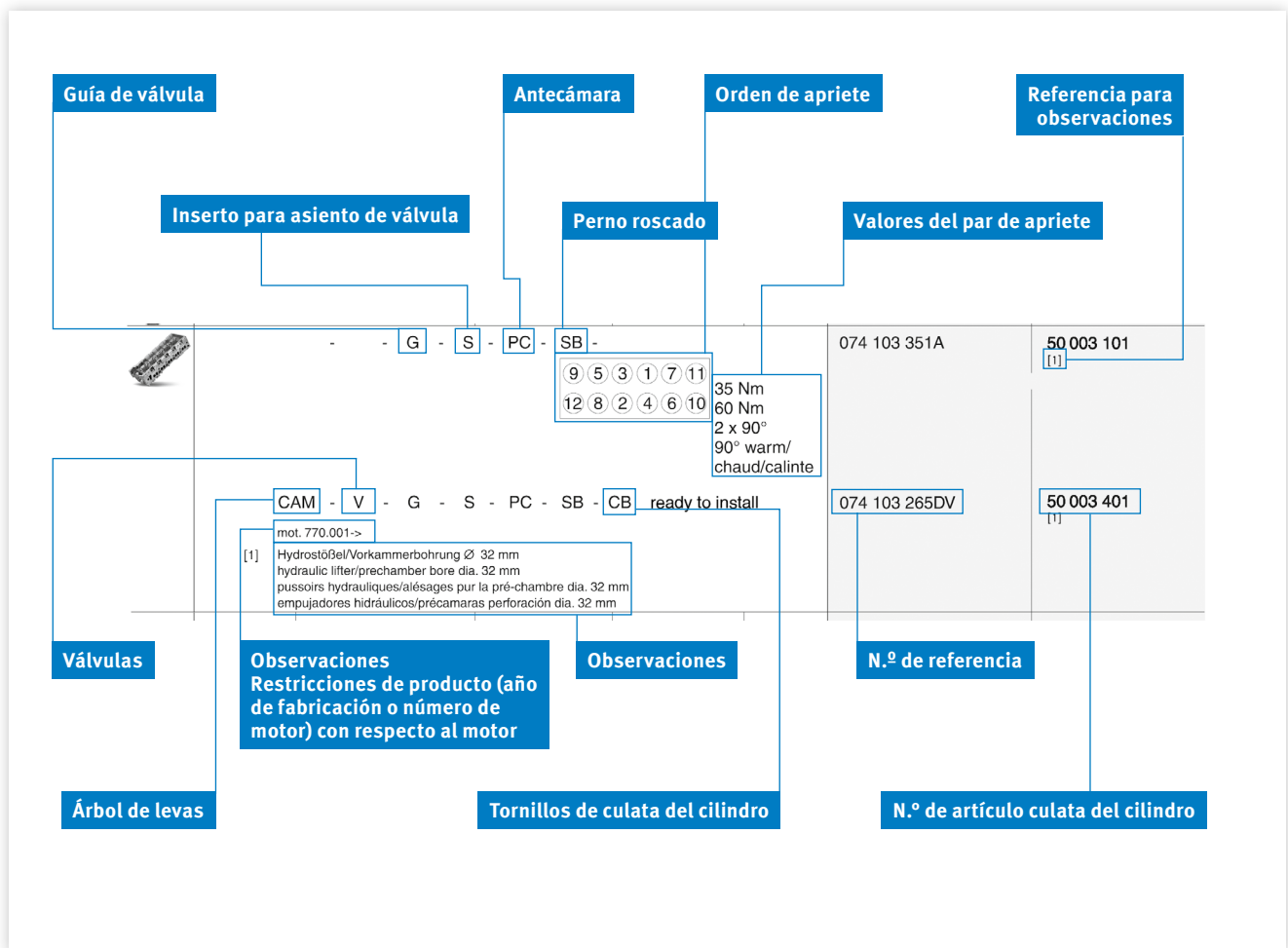



### 3. Chavetas de sujeción de válvula: ejecuciones y dimensiones

Material	Descripción	Versión	Ø de vástago de válvula	Templado por cementación	Cantidad de ranuras
KK-6H	Pieza cónica de una ranura	con apriete	6	templada	1
KK-7H	Pieza cónica de una ranura	con apriete	7	templada	1
KK-8H	Pieza cónica de una ranura	con apriete	8	templada	1
KK-9H	Pieza cónica de una ranura	con apriete	9	templada	1
KK-10H	Pieza cónica de una ranura	con apriete	10	templada	1
KK-11H	Pieza cónica de una ranura	con apriete	10	templada	1
KK-12H	Pieza cónica de una ranura	con apriete	12	templada	1
LK-5H	Pieza cónica de una ranura	con apriete	5	templada	1
LK-5.5H	Pieza cónica de una ranura	con apriete	5,5	templada	1
LK-6H	Pieza cónica de una ranura	con apriete	6	templada	1
LK-7H	Pieza cónica de una ranura	con apriete	7	templada	1
LK-1610	Pieza cónica de una ranura	con apriete	12	no templada	1
LK-2607	Pieza cónica de una ranura	con apriete	7	templada	1
LK-2615	Pieza cónica de una ranura	con apriete	9	no templada	1
MK-5H	Chaveta cónica de varias ranuras	sin apriete	5	templada	3
MK-5.5H	Chaveta cónica de varias ranuras	sin apriete	5,5	templada	3
MK-6H	Chaveta cónica de varias ranuras	sin apriete	6	templada	3
MK-7H	Chaveta cónica de varias ranuras	sin apriete	7	templada	3
MK-7H2	Chaveta cónica de varias ranuras	sin apriete	7	templada	2
MK-8H	Chaveta cónica de varias ranuras	sin apriete	8	templada	3
MK-9H	Chaveta cónica de varias ranuras	sin apriete	9	templada	3
MK-10H	Chaveta cónica de varias ranuras	sin apriete	10	templada	4
MK-12H	Chaveta cónica de varias ranuras	sin apriete	12	templada	4
RK-7	Pieza cónica de una ranura	con apriete	7	no templada	1
RK-7H	Pieza cónica de una ranura	con apriete	7	templada	1
RK-8	Pieza cónica de una ranura	con apriete	8	no templada	1
RK-8H	Pieza cónica de una ranura	con apriete	8	templada	1
RK-9H	Pieza cónica de una ranura	con apriete	9	templada	1
RK-10H	Pieza cónica de una ranura	con apriete	10	templada	1
RK-11H	Pieza cónica de una ranura	con apriete	11	templada	1
RK-9.5H	Pieza cónica de una ranura	con apriete	9,5	templada	1

ESPAÑOL

#### Chavetas cónicas con ranura KK

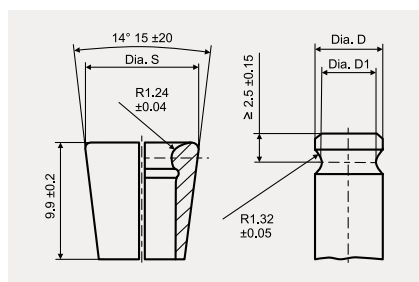

Chavetas cónicas con ranura KK, cono 1:4

Abreviación	Dimensiones del extremo del vástago de la válvula						Peso (g)
	No templado	Templado por cementación	Ø S ± 0,06	Ø D medida nominal	Ø D rango preferido desde	Ø D rango preferido hasta	
KK 6	KK 6H	10	6	5,99	5,89	4,85 ± 0,05	1,17
KK 7	KK 7H	11	7	6,99	6,89	5,85 ± 0,05	1,37
KK 8	KK 8H	12	8	7,99	7,89	6,83 ± 0,07	1,55
KK 9	KK 9H	13	9	8,99	8,89	7,8 ± 0,1	1,73
KK 10	KK 10H	14	10	9,99	9,89	8,8 ± 0,1	1,90
KK 11	KK 11H	15	11	10,99	10,89	9,8 ± 0,1	2,00
KK 12	KK 12H	16	12	11,99	11,89	10,8 ± 0,1	2,24

**Chavetas cónicas con ranura LK**

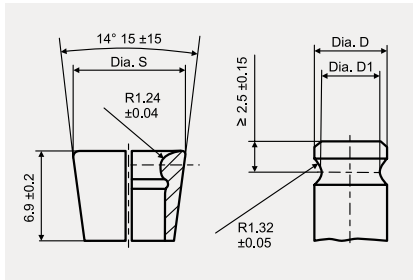

Chavetas cónicas con ranura LK, cono 1:4

Abreviación		Dimensiones del extremo del vástago de la válvula					Peso (g)
No templado	Templado por cementación	Ø S ± 0,06	Ø D medida nominal	Ø D rango preferido desde	hasta	Ø D1	
LK 5.5	LK 5.5H	8,5	5,5	5,49	5,39	4,35 ± 0,05	0,58
LK 6	LK 6H	9	6	5,99	5,89	4,85 ± 0,05	0,64
LK 6.5	LK 6.5H	9,5	6,5	6,49	6,39	5,35 ± 0,05	0,69
LK 7	LK 7H	10	7	6,99	6,89	5,85 ± 0,05	0,73

**Chavetas cónicas con ranura RK**

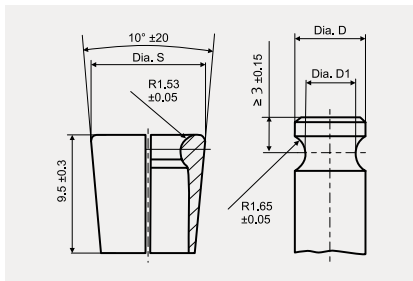

Chavetas cónicas con ranura RK, cono 1:4

Abreviación		Dimensiones del extremo del vástago de la válvula					Peso (g)
No templado	Templado por cementación	Ø S ± 0,06	Ø D medida nominal	Ø D rango preferido desde	hasta	Ø D1	
RK 6	RK 6H	8,79	6	5,99	5,89	4,15 ± 0,05	0,77
RK 7	RK 7H	9,79	7	6,99	6,89	5,15 ± 0,05	0,91
RK 8	RK 8H	10,79	8	7,99	7,89	6,13 ± 0,07	1,09
RK 9	RK 9H	11,79	9	8,99	8,89	7,1 ± 0,1	1,19
RK 10	RK 10H	12,79	10	9,99	9,89	8,1 ± 0,1	1,30
RK 11	RK 11H	13,79	11	10,99	10,89	9,1 ± 0,1	1,46
RK 12	RK 12H	14,79	12	11,99	11,89	10,1 ± 0,1	1,58

**Chaveta cónica de varias ranuras MK 5-6**

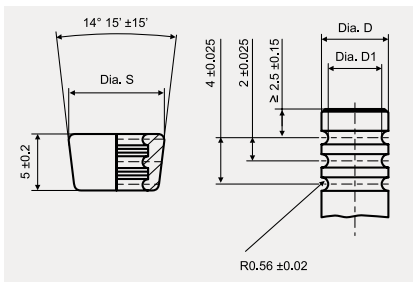

Chaveta cónica de varias ranuras MK 5-6, cono 1:4

Típos	Cantidad de rebordes	Ø D ± 0,02	Ø D1	Ø S ± 0,05	Peso (g)
MK 5	3	4,92	3,91 ± 0,05	7,0	0,30
MK 5.5	3	5,42	4,41 ± 0,05	7,5	0,35
MK 6	3	5,92	4,59 ± 0,05	8,5	0,49
MK 7	3	6,92	5,25 ± 0,05	10,5	1,12
MK 8	3	7,92	6,23 ± 0,07	11,5	1,27
MK 9	3	8,92	7,20 ± 0,1	12,5	1,40

**Chaveta cónica de varias ranuras MK 10-12**

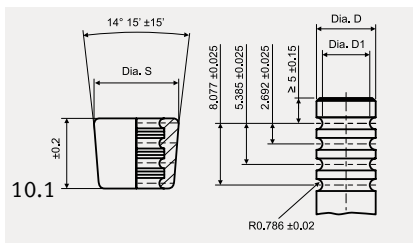

Chaveta cónica de varias ranuras MK 10-12, cono 1:4

Típos	Cantidad de rebordes	Ø D ± 0,02	Ø D1	Ø S ± 0,05	Peso (g)
MK 10	4	9,92	8,20 ± 0,1	13,8	2,04
MK 11	4	10,92	9,20 ± 0,1	14,8	2,19
MK 12	4	11,92	10,20 ± 0,1	15,8	2,82

## 4. Insertos para asiento de válvula: recomendaciones de uso e indicaciones para el montaje

### VISTA GENERAL

	HM (High Machinability)	HT (High Temperature Resistance)	HT+ (High Temperature Resistance)	G1 (High Temperature Resistance)	G2 (Highly wear-resistant)
Tipo de combustible / combustión	Gasolina (sin plomo), diésel	Gasolina (sin plomo), diésel	Gasolina (sin plomo), diésel, CNG, LPG, gas propano, combustible flexible	Gasolina (sin plomo), diésel	CNG, LPG, combustible flexible, gasolina (sin plomo), diésel
Materiales de la culata	Aluminio, fundición gris	Aluminio, fundición gris	Aluminio, fundición gris	Aluminio, fundición gris	Aluminio, fundición gris
Motores	Motores diésel y de gasolina de baja potencia con un grado de esfuerzo de bajo a normal	Motores diésel y de gasolina de alta potencia, elevada capacidad de carga y sometidos a un grado de solicitud alto	Aplicaciones de gas como LPG, CNG, gas propano, combustible flexible; Motores diésel y de gasolina de alta potencia	Motores de aspiración, motores turbo	Motores sometidos a un grado de solicitud alto, motores de potencia aumentada, todos los motores de gas mencionados arriba

#### ATENCIÓN

Las condiciones extremas de aplicación del motor y los esfuerzos a los que será sometido el respectivo motor deben ser tomados en cuenta y esto forma parte del ámbito de responsabilidad del rectificador de motores.

#### NOTA

El cambio de insertos y válvulas en el contexto de la conversión de gas representa siempre una intervención en las especificaciones originales del motor. Si los nuevos materiales combinados armonizarán y proporcionarán los resultados deseados para las condiciones modificadas, es algo que, de antemano, solo puede estimarse. Es indispensable tomar también en cuenta las condiciones extremas de aplicación y las cargas específicas del motor. Esto pertenece exclusivamente al ámbito de responsabilidad del especialista en reequipamiento de motores.

### KOLBENSCHMIDT / TRW ENGINE COMPONENTS RECOMIENDAN LOS SIGUIENTES SOLAPES / AJUSTES POR INTERFERENCIA

Diámetro exterior del inserto		Culata de hierro fundido		Culata de aluminio	
[mm]	[in]	[mm]	[in]	[mm]	[in]
20-30	0.7874 - 1.1811	0,06	0.0024	0,08	0.0031
30-40	1.1811 - 1.5748	0,08	0.0031	0,10	0.0040
40-50	1.5748 - 1.9685	0,10	0.0040	0,12	0.0047
50-60	1.9685 - 2.3622	0,12	0.0047	0,14	0.0055
60-70	2.3622 - 2.7559	0,14	0.0055	0,16	0.0063

A fin de poder ofrecerle siempre un programa completo, actualizamos regularmente y completamos nuestro surtido con nuevos tipos de productos. No dude en consultar a su persona de contacto. Esta persona le pondrá al tanto de nuestras últimas novedades.

Los materiales empleados para la fabricación de las válvulas y las guías de válvula armonizan a la perfección con los insertos y garantizan un funcionamiento óptimo.

#### Información para pedidos

En el caso de que no encuentre las dimensiones requeridas, póngase en contacto con su persona de contacto.

Las dimensiones que no aparezcan listadas se pueden fabricar previa solicitud en un plazo de 14 semanas.





## ВАЖНЫЕ УКАЗАНИЯ

Все приведенные в этом каталоге данные не являются обязательными. Мы не можем принять на себя ответственность за их правильность и полноту. Мы всегда рады получить информацию о возможных допущенных в каталоге ошибках, которые мы исправляем в следующих изданиях.

Названия, описания и номера автомобилей, производителей и т. п., а также оригинальные артикулы производителей автомобилей и двигателей приводятся только для сравнения. Соответствующие данные не являются данными о происхождении и не могут быть использованы против третьих лиц. Просим вас также учитывать, что не исключаются изменения в оснащении, внесенные производителями автомобилей или двигателей, а также изменения обозначений. По этой причине мы не можем принять на себя ответственность за использование списков сравнения.

Мы оставляем за собой право в любое время изменять спецификации, материалы, внешний вид и комплекты поставки наших компонентов. Поэтому приведенные в каталоге рисунки не являются обязательными.

Перед установкой всегда необходимо проверять пригодность приобретенного компонента к использованию в намеченных целях. На основании предоставленных нами данных нельзя делать заключения о наличии определенных характеристик или о пригодности к использованию в какой-либо области применения. В частности, следует учесть, что предлагаемые в каталоге компоненты не предназначены для использования в воздушных и космических транспортных средствах. В случае применения в двигателях, не предназначенных для дорожного транспорта (напр., судовых и стационарных двигателях, а также тяговых двигателях рельсового транспорта) необходимо учитывать, что при одном и том же обозначении двигателей в них могут использоваться разные компоненты (например, поршни). По этой причине перед установкой компонентов может потребоваться компетентная консультация производителя или авторизованной СТО. Мы также обращаем ваше внимание на то, что установку компонентов всегда должны выполнять квалифицированные специалисты. Рисунки, схематические чертежи и прочие данные используются для пояснения и иллюстрации; они не могут служить основой для установки.

Любое копирование, повторение, распространение или публичная демонстрация настоящего каталога или его частей возможны только с нашего предварительного письменного согласия с соответствующим указанием источника. С момента выпуска данного каталога все предыдущие издания теряют свою силу.

## СЕРТИФИКАТЫ

Компания MS Motorservice International GmbH успешно прошла сертификацию системы менеджмента качества по ISO 9001 и системы экологического менеджмента по ISO 14001.





ИНФОРМАЦИЯ КАТАЛОГА СОДЕРЖИТСЯ ТАКЖЕ В НАШЕМ ОНЛАЙН-КАТАЛОГЕ, В НАШЕМ ПРИЛОЖЕНИИ И НА TECALLIANCE.

**Дополнительная информация:**  
[catalog.ms-motorservice.com](http://catalog.ms-motorservice.com)  
[motorservice.app](http://motorservice.app)

**ОГЛАВЛЕНИЕ**
**СТР.**

	Важные указания	74
	Менеджмент качества	74
	Передача ноу-хау: специальные знания от эксперта	76
1.	Компоненты привода клапанов и головки блоков цилиндров	79
<b>2.</b>	<b>УКАЗАНИЯ ПО ПОЛЬЗОВАНИЮ КАТАЛОГОМ</b>	<b>82</b>
3.	Сухари клапанов: исполнения и размеры	88
4.	Рекомендации по применению и указания по монтажу	90
5.	Перечни размеров колец седла клапана	109
5.1	Классификация по наружному диаметру D (мм)	110
5.2	Классификация по наружному диаметру D (дюймы)	117
6.	Дополнение к программе	123
7.	Перечень изготовителей	139
<b>8.</b>	<b>ПРОИЗВОДСТВЕННЫЙ АССОРТИМЕНТ</b>	<b>141</b>
9.	Kolbenschmidt / BF / TRW Engine Components №: области применения	1419
10.	Список сравнения	1457
11.	Процедура рассмотрения рекламаций / формуляр для рекламаций	

**ГРУППА MOTORSERVICE**
**КАЧЕСТВО И СЕРВИС ИЗ ОДНИХ РУК**

Группа Motorservice — это организация по сбыту продукции концерна Rheinmetall, активно действующая на мировом рынке послепродажного обслуживания автомобилей. Она является ведущей фирмой, предлагающей компоненты двигателей для свободного рынка запасных частей. Клиенты Motorservice получают из магазинов и СТО широкий и глубокий ассортимент продукции высочайшего качества, охватывающий премиум-марки Kolbenschmidt, Pierburg, TRW Engine Components, а также марки BF и turbo by Intec.

**RHEINMETALL**
**ТЕХНОЛОГИИ В СФЕРЕ МОБИЛЬНОСТИ БУДУЩЕГО**

В качестве поставщика автомобильной промышленности в мировом масштабе Rheinmetall, благодаря своему профессионализму, занимает на соответствующих рынках ведущие в мире позиции в таких областях, как снабжение воздухом, уменьшение содержания вредных веществ и насосы, а также по разработке и производству поршней, блоков цилиндров двигателей и подшипников скольжения, включая поставку запасных частей к ним. Разработка продуктов осуществляется в тесном сотрудничестве с известными компаниями-производителями транспортных средств.

# ПЕРЕДАЧА НОУ-ХАУ СПЕЦИАЛЬНЫЕ ЗНАНИЯ ОТ ЭКСПЕРТА

## КУРСЫ ОБУЧЕНИЯ ПО ВСЕМУ МИРУ

### Напрямую от изготовителя

Ежегодно около 4 500 механиков и техников приобретают новые знания на наших курсах обучения и семинарах, которые мы проводим как на местах, в различных странах мира, так и в наших учебных центрах, расположенных в Нойенштадте, Дормагене и Тамме (Германия).

## ТЕХНИЧЕСКАЯ ИНФОРМАЦИЯ

### Практические навыки для практического применения

Благодаря нашим Product Information, Service Information, техническим брошюрам и плакатам Вы всегда будете идти в ногу со временем.

## ТЕХНИЧЕСКИЕ ВИДЕОФИЛЬМЫ

### Передача знаний по видео

Наши видеофильмы содержат проверенные на практике инструкции по монтажу и системные пояснения к нашим продуктам.



## ПРОДУКТЫ В ФОКУСЕ ВНИМАНИЯ ОНЛАЙН

### Наглядное описание наших решений

Вы узнаете много интересного о наших продуктах, установленных внутри двигателя и вокруг него, благодаря интерактивным элементам, анимации и видеороликам.

## ВИРТУАЛЬНЫЙ МАГАЗИН

### Ваш прямой доступ к нашим продуктам

Оформление заказов круглосуточно. Быстрый контроль наличия. Обширный поиск продуктов по двигателю, транспортному средству, размерам и т. д.

## НОВОСТИ

### Регулярно рассылаемая по e-mail информация

Подпишитесь онлайн на наш бюллетень, и Вы будете регулярно и бесплатно получать информацию о новых продуктах в программе, технические издания и многое другое.

## ИНДИВИДУАЛЬНАЯ ИНФОРМАЦИЯ

### Специально для наших заказчиков

Подробная информация и сервис из нашего обширного спектра услуг, например: индивидуализированные материалы для содействия сбыту, поддержка сбыта, техническая поддержка и многое другое.



## ТЕХНИПЕДИЯ

### Техническая информация, связанная с двигателями

В нашей технпедии мы поделимся с Вами своими ноу-хау. Здесь Вы найдете специальные знания напрямую от эксперта.

## ПРИЛОЖЕНИЕ MOTORSERVICE

### Мобильный доступ к техническому ноу-хау

Здесь Вы быстро и просто получите самую актуальную информацию и услуги по нашим продуктам.

## СОЦИАЛЬНЫЕ СЕТИ

### Всегда в курсе

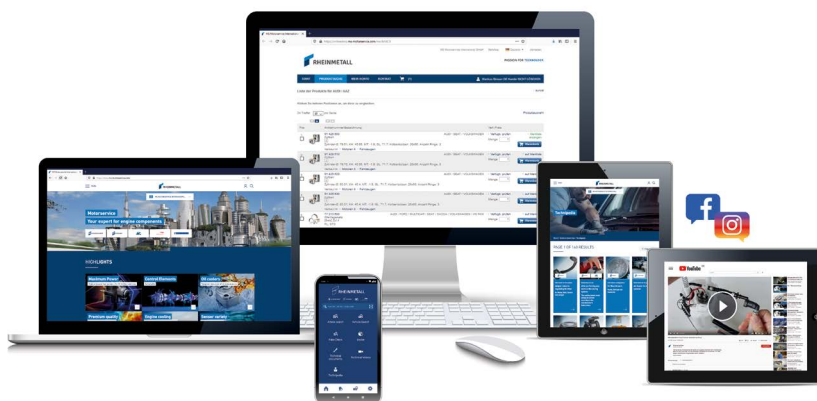

[www.ms-motorservice.com](http://www.ms-motorservice.com)







РУССКИЙ

# 1. Компоненты привода клапанов и головки блока в цилиндрах

## КЛАПАНЫ

### Качество и безопасность на много километров

За период эксплуатации в 200 000 км клапаны подвергаются смене нагрузки около 200 миллионов раз. Поэтому клапаны TRW Engine Components рассчитывают на основе современных методов (FEA) и перед допуском к серийному производству подвергают обширным испытаниям.



## НАПРАВЛЯЮЩИЕ ВТУЛКИ КЛАПАНОВ

### Соосность на высоком уровне

Направляющая втулка обеспечивает соосность клапана и седла клапана в экстремальных условиях, отводя еще при этом часть тепла к головке блока цилиндров. Чтобы выдерживать такие экстремальные условия, решающую роль играют используемый материал и его свойства – выбирайте самый надежный вариант: высококачественные продукты TRW Engine Components.



## СЕДЛА КЛАПАНОВ

### Подходящий материал для каждой области применения

Растущие тепловые и механические нагрузки, воздействующие на седла клапанов в современных двигателях, вряд ли смогут выдержать материалы, изготовленные традиционными методами литья. Поэтому наряду с чугунными седлами клапанов компания Motorservice предлагает также металлокерамические седла клапанов, изготовленные из материалов трех различных сочетаний.



## РАСПРЕДЕЛИТЕЛЬНЫЕ ВАЛЫ

### Износостойкие кулачки для мощного двигателя с долгим сроком службы

Распределительные валы из программы поставки Motorservice отличаются высокой прочностью, благодаря чему они в течение длительного периода времени выдерживают значительные нагрузки, вызывающие изгиб и кручение. В зависимости от цели применения, распределительные валы изготавливают в литом или ковном исполнении.









## ГИДРАВЛИЧЕСКИЙ ТОЛКАТЕЛЬ

### Отсутствие техобслуживания и автоматическая плавность хода

Благодаря конструкции гидравлического толкателя отпадает необходимость в проверке и регулировании зазора, и тем самым сокращаются высокие расходы на техобслуживание. Гидравлические толкатели действуют почти без зазора. Это снижает эксплуатационный износ, обеспечивая плавность хода и эффективность двигателей.



## РЕГУЛИРУЮЩИЕ ЭЛЕМЕНТЫ

### Надежное соединение

Точная и надежная передача усилия между аспределятельным валом и головкой блока цилиндров возможна только с помощью высококачественных регулирующих элементов. Предлагаемые Motorservice регулирующие элементы гарантируют точность и долговечность всего газораспределительного механизма.



## ГОЛОВКИ БЛОКОВ ЦИЛИНДРОВ

### Индивидуальная комплектация

Motorservice предлагает широкий выбор головок блоков цилиндров для легковых и грузовых автомобилей. Для удобства при ремонте поставляются также головки блоков цилиндров с индивидуально смонтированными клапанами и пружинами клапанов.



Техническую информацию о продуктах, монтаже и приработке вы найдете на сайте: [www.ms-motorservice.com](http://www.ms-motorservice.com)

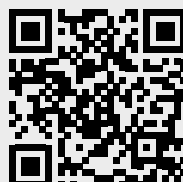



## 2. Указания по пользованию каталогом

### ИНДЕКС ДВИГАТЕЛЕЙ



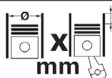



Вначале для соответствующего изготовителя приводится подробная справка по поиску. Обозначения двигателей указываются в алфавитно-цифровом порядке возрастания.

KOLBENSCHMIDT		DEUTZ								
INDEX										
		Cyl.		mm	cm <sup>3</sup>	Comp. Ratio	ε	kW	PS	Pos
A 6 M 816		D (AN) 6		142 x 160	15204	2	16:1	145-172	197-234	45
A 6 M 816 R		D (LA) 6		142 x 160	15204	2	16:1			45
A 6 M 816 U		D (LA) 6		142 x 160	15204	2	16:1			45
A 6 M 816 W		D (LA) 6		142 x 160	15204	2	16:1			45

**Двигатель** **Номер позиции**

### ИНДЕКС ТРАНСПОРТНЫХ СРЕДСТВ

Вначале для соответствующего изготовителя приводится подробная справка по поиску. Транспортные средства указываются в алфавитно-цифровом порядке возрастания по Класстранспортных средств.

KOLBENSCHMIDT		AUDI						
INDEX								
 		Pos	 		Pos			
A1 (8X)			A4 1.8i Turbo 20V	01.1999 → 06.2000	ANB	B	23	
1.4 TFSI 05.2010 →	CAXA	B 3	A4 1.8i Turbo 20V	06.2000 → 09.2001	AWT	B	27	
2.0 TDI 09.2011 →	CFHB	D 33	A4 1.9 TDI	01.1995 → 07.1996	1Z	D	11	
A2 (8Z)			A4 1.9 TDI	03.1996 → 07.1999	AFN	D	11	

**Транспортное средство / серия моделей** **Номер позиции**

СТРОКА ДВИГАТЕЛЯ

<b>Номер позиции</b> (последовательная нумерация в рамках одного изготовителя) <b>24</b>		<b>Номинальный Ø цилиндра</b> <b>115</b>		<b>Сyl. 6</b>		<b>Год выпуска с → по</b> 03.1988 → 04.1994		<b>Тип зарядки*</b> D [AN]		<b>Семейства поршней для приведенных двигателей. Подробности применения см. в каталоге поршней.</b> 93 152 6..., 91 151 6...		<b>Степень сжатия</b> 16:1		<b>Ход</b> 125 mm	
<b>Обозначение двигателя с указанием исполнения катализатора / вида вредных веществ</b> PL		<b>Номер двигателя / серийный номер</b> St/A 50,000		<b>Вид топлива*</b> 53,708 / 53,69		<b>Количество цилиндров</b> 6		<b>Литраж</b> 7800 cm <sup>3</sup>		<b>Количество клапанов</b> 2V		<b>Мощность от → до</b> 178 KW (242 PS)		<b>Ссылка на примечания</b> 77 099 608	
<b>Примечания</b> (1) Conrod length = 220 mm		mot. → 456789		29,00		1,822		STD 0,30		4		(1)			

\* См. перечень сокращений

**ДАННЫЕ ПРОДУКТА**

Страницы каталога состоят из приведенных ниже блоков информации:

Сухари клапанов
Поле изготовителя

Номер позиции	Строка пиктограмм	Строка двигателя	Клапаны
KOLBENSCHMIDT                              TRW EngineComponents		Изготовитель	
TRW EngineComponents			
<b>24</b>	<b>115 Cyl. 6</b>		
<b>D 5TC EURO 1    03.1988 -&gt; 04.1994    D [AN]    6    7800 cm3    2V    178 kW (242 PS)    16:1    125 mm</b> <small>[1] Conrod length = 220 mm    mot. -&gt; 456789    94 347 6.    [1]</small>			
	IN [2] 39 x 7,9 x 114,3 M+0,8 EX [2] 33,4 x 7,9 x 114,3 S+0,15	I - C - Na - 44,5° - Y - 22 - V RA - C - - 44,5° - Y - 18 - III	105-35470 105-03364
	[50] 8		12345678    KK-8
	IN/EX [4] 12,06/15,2x7,98 x36,5	B1	056 103 419A    81-3310
	IN/EX [4] 45,08 / 37 x 8,3	T    45°	352 053 16 31 352 053 22 31    50 004 885
	491	AS/ES/L/R	028 109 101E    50 006 204
	TAP [8] H 21,4 x 68 x 28		6 40 051 6 40 059 90295215    50 006 457
	[4]		059 109 444    50 006 410
	- - G - S - PC - SB -  CAM - V - G - S - PC - SB - CB ready to install <small>mot. 770.001-&gt;</small>	9 5 3 1 7 11 12 8 2 4 6 10 35 Nm 60 Nm 2 x 90° 90° warm/ chaud/calinte	074 103 351A    50 003 101 [1] 074 103 265DV    50 003 401 [1]
<small>[1] Hydrosößel/Vorkammerbohrung Ø 32 mm                      hydraulic lifter/prechamber bore dia. 32 mm                      pousseurs hydrauliques/alésages pur la pré-chambre dia. 32 mm                      empuadores hidráulicos/précamaras perforación dia. 32 mm</small>			

Седла клапанов
Примечания
Головка блока цилиндров
Толкатель

Направляющие втулки клапанов
Коромысло/балансир
Распределительные валы

\*См. перечень сокращений

РУССКИЙ

КЛАПАНЫ

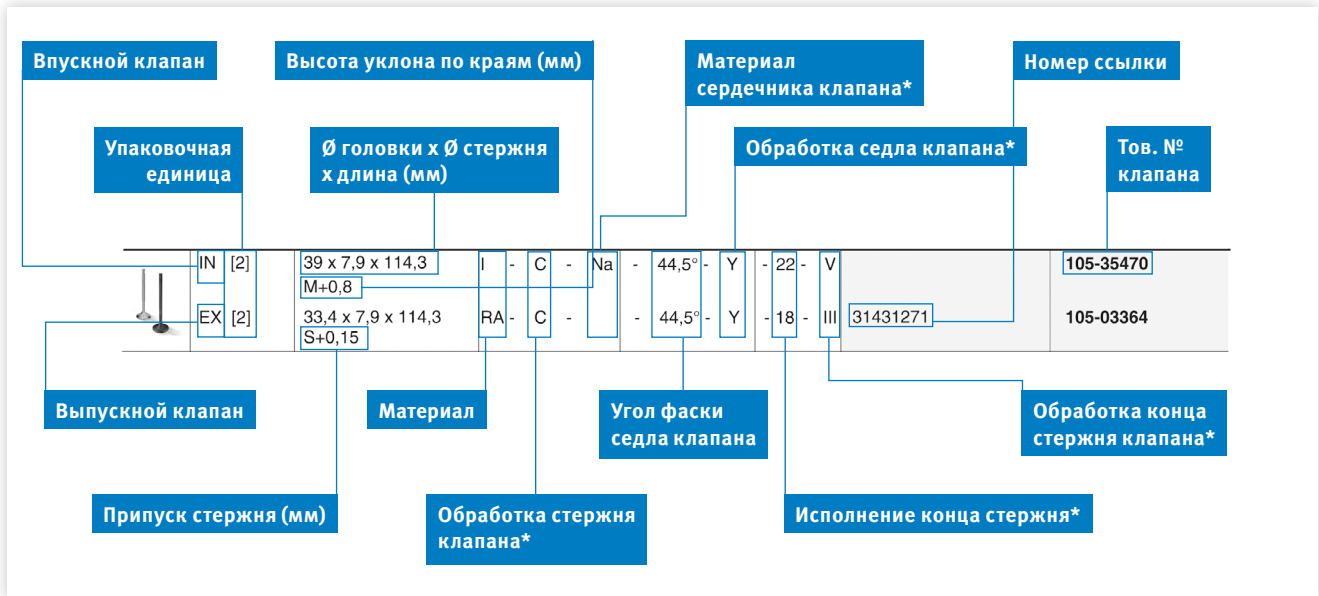

СУХАРИ КЛАПАНОВ

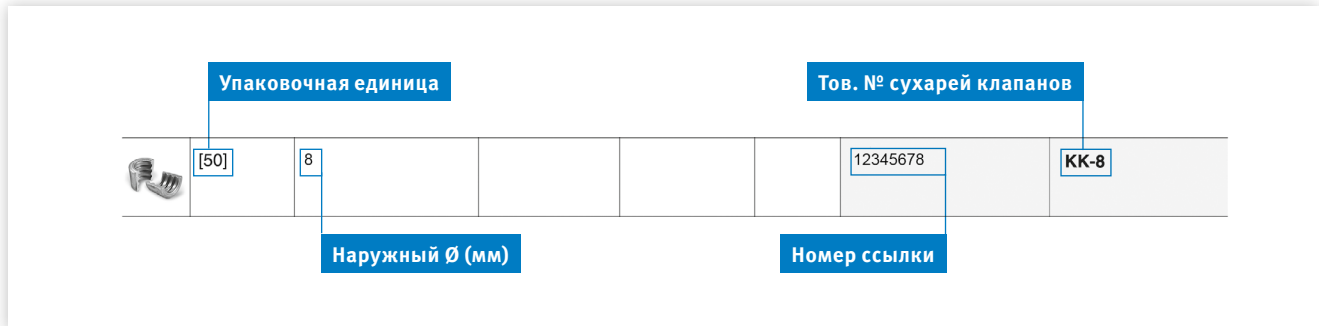

НАПРАВЛЯЮЩИЕ ВТУЛКИ КЛАПАНОВ



\*См. перечень сокращений



### СЕДЛА КЛАПАНОВ

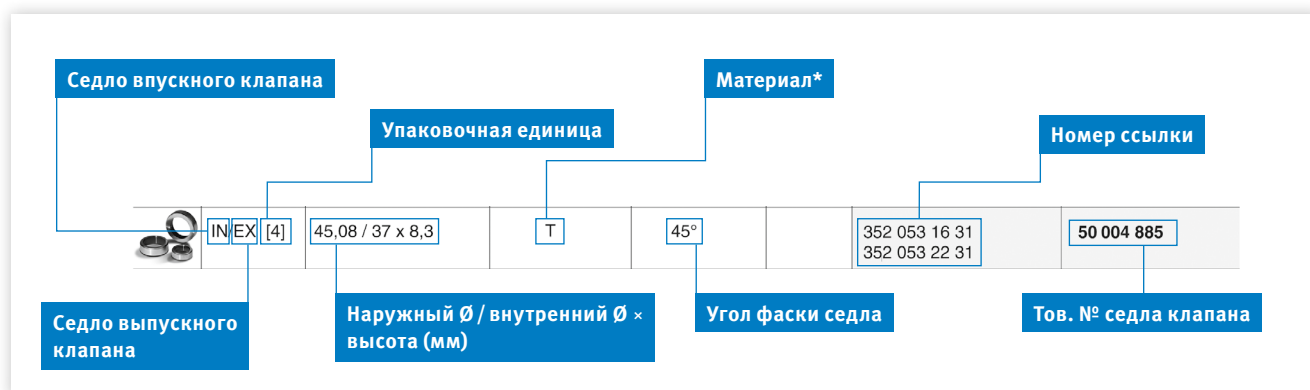

IN EX [4]	45,08 / 37 x 8,3	T	45°	352 053 16 31 352 053 22 31	50 004 885
Седло впускного клапана	Упаковочная единица	Материал*	Угол фаски седла	Номер ссылки	Тов. № седла клапана
Седло выпускного клапана	Наружный Ø / внутренний Ø × высота (мм)				

### РАСПРЕДЕЛИТЕЛЬНЫЕ ВАЛЫ

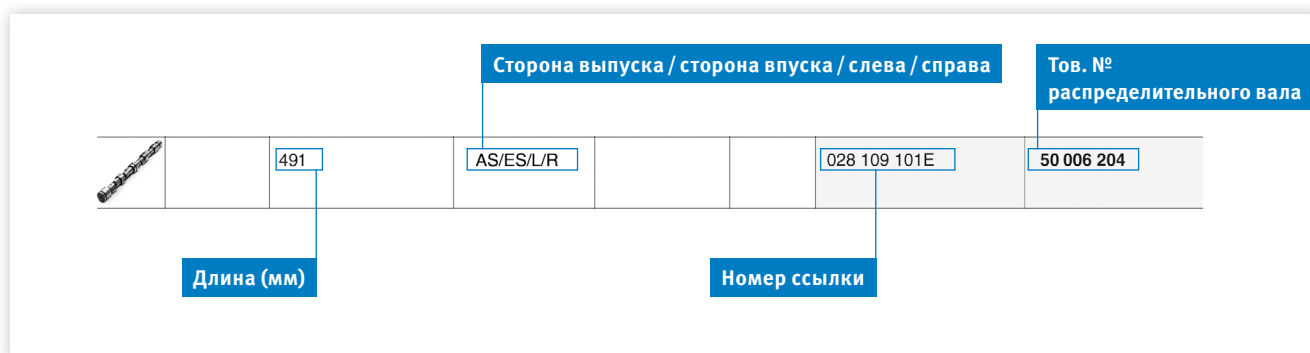

491	AS/ES/L/R	028 109 101E	50 006 204
Длина (мм)	Сторона выпуска / сторона впуска / слева / справа	Номер ссылки	Тов. № распределительного вала

### ТОЛКАТЕЛЬ

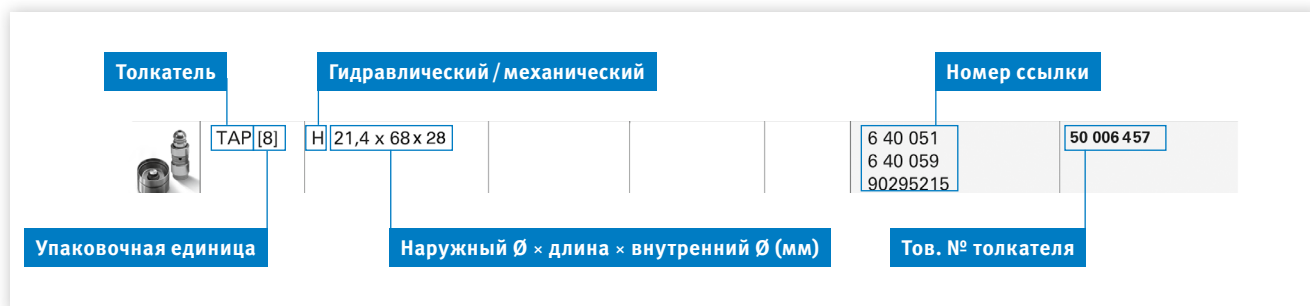

TAP [8]	H   21,4 x 68 x 28	6 40 051 6 40 059 90295215	50 006 457
Упаковочная единица	Гидравлический / механический	Номер ссылки	Тов. № толкателя
	Наружный Ø × длина × внутренний Ø (мм)		

КОРОМЫСЛО / БАЛАНСИР

	[4]				059 109 444	50 006 410
---	-----	--	--	--	-------------	------------

Упаковочная единица

Номер ссылки

Тов. № коромысла / балансира

ГОЛОВКА БЛОКА ЦИЛИНДРОВ

	-	G	-	S	-	PC	-	SB	-	074 103 351A	50 003 101 [1]
---	---	---	---	---	---	----	---	----	---	--------------	-------------------

Направляющая втулка клапана

Предкамера

Последовательность затяжки

Ссылка на примечания

Седло клапана

Распорный болт

Значения затяжки

35 Nm  
60 Nm  
2 x 90°  
90° warm/  
chaud/calinte

Клапан

Примечания  
Ограничения (год выпуска или номер двигателя) продукта для двигателя

Примечания

Номер ссылки

Тов. № головки блока цилиндров

Распределительный вал

Болты крепления головки блока цилиндров

Тов. № головки блока цилиндров

074 103 265DV

50 003 401  
[1]

CAM - V - G - S - PC - SB - CB - ready to install

mot. 770.001->

[1] Hydrostößel/Vorkammerbohrung Ø 32 mm  
hydraulic lifter/prechamber bore dia. 32 mm  
poussoirs hydrauliques/alésages pur la pré-chambre dia. 32 mm  
empujadores hidráulicos/précamaras perforación dia. 32 mm

9 5 3 1 7 11  
12 8 2 4 6 10

РУССКИЙ

### 3. Сухари клапанов: исполнения и размеры

Материал	Описание	Исполнение	Ø стержня клапана	Закалка для применения	Количество канавок
KK-6H	Одноканавочный сухарь	клеммовое	6	с закалкой	1
KK-7H	Одноканавочный сухарь	клеммовое	7	с закалкой	1
KK-8H	Одноканавочный сухарь	клеммовое	8	с закалкой	1
KK-9H	Одноканавочный сухарь	клеммовое	9	с закалкой	1
KK-10H	Одноканавочный сухарь	клеммовое	10	с закалкой	1
KK-11H	Одноканавочный сухарь	клеммовое	10	с закалкой	1
KK-12H	Одноканавочный сухарь	клеммовое	12	с закалкой	1
LK-5H	Одноканавочный сухарь	клеммовое	5	с закалкой	1
LK-5.5H	Одноканавочный сухарь	клеммовое	5,5	с закалкой	1
LK-6H	Одноканавочный сухарь	клеммовое	6	с закалкой	1
LK-7H	Одноканавочный сухарь	клеммовое	7	с закалкой	1
LK-1610	Одноканавочный сухарь	клеммовое	12	без закалки	1
LK-2607	Одноканавочный сухарь	клеммовое	7	с закалкой	1
LK-2615	Одноканавочный сухарь	клеммовое	9	без закалки	1
MK-5H	Многоканавочный сухарь	неклеммовое	5	с закалкой	3
MK-5.5H	Многоканавочный сухарь	неклеммовое	5,5	с закалкой	3
MK-6H	Многоканавочный сухарь	неклеммовое	6	с закалкой	3
MK-7H	Многоканавочный сухарь	неклеммовое	7	с закалкой	3
MK-7H2	Многоканавочный сухарь	неклеммовое	7	с закалкой	2
MK-8H	Многоканавочный сухарь	неклеммовое	8	с закалкой	3
MK-9H	Многоканавочный сухарь	неклеммовое	9	с закалкой	3
MK-10H	Многоканавочный сухарь	неклеммовое	10	с закалкой	4
MK-12H	Многоканавочный сухарь	неклеммовое	12	с закалкой	4
RK-7	Одноканавочный сухарь	клеммовое	7	без закалки	1
RK-7H	Одноканавочный сухарь	клеммовое	7	с закалкой	1
RK-8	Одноканавочный сухарь	клеммовое	8	без закалки	1
RK-8H	Одноканавочный сухарь	клеммовое	8	с закалкой	1
RK-9H	Одноканавочный сухарь	клеммовое	9	с закалкой	1
RK-10H	Одноканавочный сухарь	клеммовое	10	с закалкой	1
RK-11H	Одноканавочный сухарь	клеммовое	11	с закалкой	1
RK-9.5H	Одноканавочный сухарь	клеммовое	9,5	с закалкой	1

#### Одноканавочные сухари KK

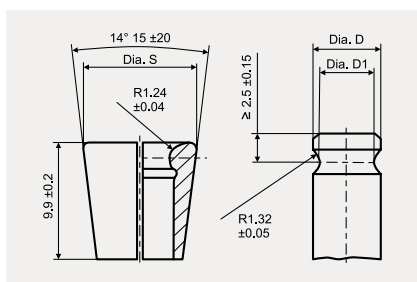

Одноканавочные сухари KK, конус 1:4

Краткое обозначение	Размеры конца стержня клапана						
	Закалка для применения	Ø S ± 0.06	Предпочт. область Ø D				Вес (г)
Без закалки	Ø D номин. размер		от	до	Ø D1		
KK 6	KK 6H	10	6	5.99	5.89	4.85 ± 0.05	1.17
KK 7	KK 7H	11	7	6.99	6.89	5.85 ± 0.05	1.37
KK 8	KK 8H	12	8	7.99	7.89	6.83 ± 0.07	1.55
KK 9	KK 9H	13	9	8.99	8.89	7.8 ± 0.1	1.73
KK 10	KK 10H	14	10	9.99	9.89	8.8 ± 0.1	1.90
KK 11	KK 11H	15	11	10.99	10.89	9.8 ± 0.1	2.00
KK 12	KK 12H	16	12	11.99	11.89	10.8 ± 0.1	2.24

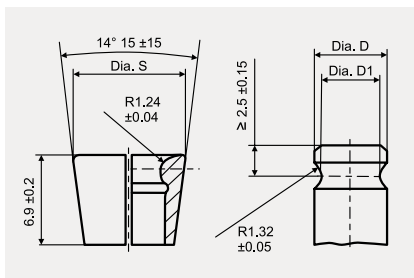
**Одноканавочные сухари LK**

Одноканавочные сухари LK, конус 1:4

Краткое обозначение		Размеры конца стержня клапана					
Без закалки	Закалка для применения	$\varnothing S \pm 0.06$	$\varnothing D$ номин. размер	Предпочт. область $\varnothing D$		$\varnothing D1$	Вес (г)
LK 5.5	LK 5.5H	8.5	5.5	5.49	5.39	$4.35 \pm 0.05$	0.58
LK 6	LK 6H	9	6	5.99	5.89	$4.85 \pm 0.05$	0.64
LK 6.5	LK 6.5H	9.5	6.5	6.49	6.39	$5.35 \pm 0.05$	0.69
LK 7	LK 7H	10	7	6.99	6.89	$5.85 \pm 0.05$	0.73

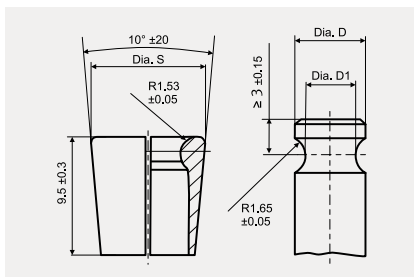
**Одноканавочные сухари RK**

Одноканавочные сухари RK, конус 1:4

Краткое обозначение		Размеры конца стержня клапана					
Без закалки	Закалка для применения	$\varnothing S \pm 0.06$	$\varnothing D$ номин. размер	Предпочт. область $\varnothing D$		$\varnothing D1$	Вес (г)
RK 6	RK 6H	8.79	6	5.99	5.89	$4.15 \pm 0.05$	0.77
RK 7	RK 7H	9.79	7	6.99	6.89	$5.15 \pm 0.05$	0.91
RK 8	RK 8H	10.79	8	7.99	7.89	$6.13 \pm 0.07$	1.09
RK 9	RK 9H	11.79	9	8.99	8.89	$7.1 \pm 0.1$	1.19
RK 10	RK 10H	12.79	10	9.99	9.89	$8.1 \pm 0.1$	1.30
RK 11	RK 11H	13.79	11	10.99	10.89	$9.1 \pm 0.1$	1.46
RK 12	RK 12H	14.79	12	11.99	11.89	$10.1 \pm 0.1$	1.58

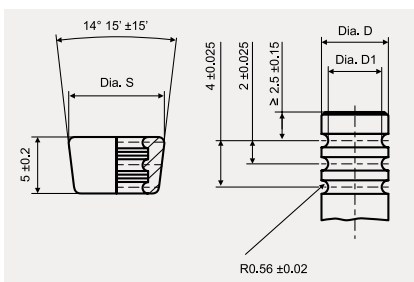
**Многоканавочные сухари МК 5 – 6**

Многоканавочные сухари МК 5 – 6, конус 1:4

Количество выступов		$\varnothing D \pm 0.02$	$\varnothing D1$	$\varnothing S \pm 0.05$	Вес (г)
МК 5	3	4.92	$3.91 \pm 0.05$	7.0	0.30
МК 5.5	3	5.42	$4.41 \pm 0.05$	7.5	0.35
МК 6	3	5.92	$4.59 \pm 0.05$	8.5	0.49
МК 7	3	6.92	$5.25 \pm 0.05$	10.5	1.12
МК 8	3	7.92	$6.23 \pm 0.07$	11.5	1.27
МК 9	3	8.92	$7.20 \pm 0.1$	12.5	1.40

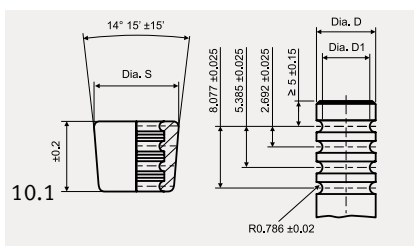
**Многоканавочные сухари МК 10 – 12**

Многоканавочные сухари МК 10 – 12, конус 1:4

Количество выступов		$\varnothing D \pm 0.02$	$\varnothing D1$	$\varnothing S \pm 0.05$	Вес (г)
МК 10	4	9.92	$8.20 \pm 0.1$	13.8	2.04
МК 11	4	10.92	$9.20 \pm 0.1$	14.8	2.19
МК 12	4	11.92	$10.20 \pm 0.1$	15.8	2.82



## 4. Седла клапанов: рекомендации по применению и указания по монтажу

### ОБЗОР

	НМ (High Machinability)	НТ (High Temperature Resistance)	НТ+ (High Temperature Resistance)	G1 (High Temperature Resistance)	G2 (Highly wear-resistant)
Вид топлива / сгорание	бензин (неэтилированный), дизель	бензин (неэтилированный), дизель	бензин (неэтилированный), дизель, CNG, LPG, пропан, Flex Fuel	бензин (неэтилированный), дизель	CNG, LPG, Flex Fuel, бензин (неэтилированный), дизель
Материалы головки блока цилиндров	алюминий, серый чугун	алюминий, серый чугун	алюминий, серый чугун	алюминий, серый чугун	алюминий, серый чугун
Двигатели	маломощные бензиновые и дизельные двигатели, подверженные нагрузкам от низких до обычных	мощные бензиновые и дизельные двигатели с высоким наддувом, подверженные высоким нагрузкам	на газе, например, LPG, CNG, пропан, Flex Fuel; мощные бензиновые и дизельные двигатели	безнаддувные двигатели, турбодвигатели	двигатели, подверженные высоким нагрузкам; двигатели с повышенной мощностью; все вышеназванные газовые двигатели

#### ВНИМАНИЕ

Необходимо учитывать экстремальные условия эксплуатации, а также высокие нагрузки на соответствующий двигатель; ответственность за них несет предприятие по ремонту двигателей.

#### УКАЗАНИЕ

Замена седел клапанов и клапанов в рамках переоборудования на газовое топливо всегда представляет собой вмешательство в первоначальные спецификации двигателя. Будут ли гармонировать новые сочетания материалов друг с другом и достигнуты желаемые результаты при измененных условиях, заранее можно лишь предположить. Необходимо учитывать экстремальные условия эксплуатации и специфические нагрузки на двигатель. Ответственность за это несет только фирма по переоборудованию двигателей.

### KOLBENSCHMIDT / TRW ENGINE COMPONENTS РЕКОМЕНДУЕТ СЛЕДУЮЩИЕ ЗНАЧЕНИЯ ПЕРЕКРЫТИЯ / ПРЕССОВЫЕ ПОСАДКИ:

Наружный диаметр седла клапана		Головка блока цилиндров из чугуна		Головка блока цилиндров из алюминия	
[мм]	[дюйм]	[мм]	[дюйм]	[мм]	[дюйм]
20 – 30	0.7874 – 1.1811	0,06	0.0024	0,08	0.0031
30 – 40	1.1811 – 1.5748	0,08	0.0031	0,10	0.0040
40 – 50	1.5748 – 1.9685	0,10	0.0040	0,12	0.0047
50 – 60	1.9685 – 2.3622	0,12	0.0047	0,14	0.0055
60 – 70	2.3622 – 2.7559	0,14	0.0055	0,16	0.0063

Чтобы всегда предлагать вам полную программу, наш ассортимент регулярно дополняется новыми типами. Обращайтесь к своему контактному лицу за актуальной информацией. Материалы клапанов и направляющих втулок согласованы с седлами клапанов и гарантируют оптимальную эксплуатацию.

#### Указание по заказу

Если вам понадобится другой размер, не указанный в перечне, просим вас обратиться к своему контактному лицу. Любой отсутствующий размер может быть реализован по запросу в течение 14 недель.

## ٤- حلقات مقعد الصمام - توصيات الاستخدام وإرشادات التركيب

عرض عام

G2 (مقاومة عالية للتآكل)	G1 (مقاومة عالية لدرجة الحرارة)	HT+ (مقاومة عالية لدرجة الحرارة)	HT (مقاومة عالية لدرجة الحرارة)	HM (قابلية تشغيل عالية)	نوع الوقود/ الاحتراق
غاز CNG، LPG، Flex Fuel، بنزين (خالٍ من الرصاص)، ديزل	بنزين (خالٍ من الرصاص)، ديزل	بنزين (خالٍ من الرصاص)، ديزل، الغاز الطبيعي المضغوط (CNG)، غاز LPG، غاز البروبان، Flex Fuel	بنزين (خالٍ من الرصاص)، ديزل	بنزين (خالٍ من الرصاص)، ديزل	
الألومنيوم، الحديد الرمادي المسبوك	الألومنيوم، الحديد الرمادي المسبوك	الألومنيوم، الحديد الرمادي المسبوك	الألومنيوم، الحديد الرمادي المسبوك	الألومنيوم، الحديد الرمادي المسبوك	مواد رأس الأسطوانة
محركات عالية الإجهاد، محركات متصاعدة الأداء، كل ما سبق ذكره من محركات الغاز	محركات سحب طبيعي، محركات تريبو	استخدامات الغاز مثل LPG، CNG، غاز البروبان، Flex Fuel محركات البنزين والديزل قوية الأداء	محركات بنزين وديزل قوية الأداء ذات شحن عالٍ وإجهاد مرتفع	محركات بنزين وديزل ضعيفة الأداء ذات قدرة إجهاد محدودة إلى طبيعية	المحركات

### ملحوظة

### تنبيه

يعد دوماً استبدال حلقات مقعد الصمام والصمامات في إطار التعديل لاستخدام الغاز تدخلاً في مواصفات المحرك الأصلية. لا يُسمح بتقييم ما إذا كانت ازدواجات المواد الجديدة منسجمة مع بعضها البعض وتظهر معها النتائج المرغوبة في ظل الظروف المتغيرة إلا في طور الإعداد والتحضير. يجب أن تؤخذ ظروف التشغيل القصوى وإجهادات المحرك المميّزة بعين الاعتبار. وهذا يقع بشكل حصري ضمن نطاق مسؤولية من يقوم بتعديل المحرك.

يجب أن تؤخذ ظروف التشغيل القصوى والإجهادات العالية لكل محرك على حدة بعين الاعتبار ووضعها في نطاق مسؤولية القائم بإصلاح المحرك.

توصي شركة Kolbenschmidt / TRW Engine Components بالتغطيات/مواعمات الكبس التالية

رأس الأسطوانة من الألومنيوم		رأس الأسطوانة من الحديد المصبوب		القطر الخارجي لحلقة المقعد	
[بوصة]	[مم]	[بوصة]	[مم]	[بوصة]	[مم]
٠,٠٣١	٠,٠٨	٠,٠٢٤	٠,٠٦	١,١٨١١-٠,٧٨٧٤	٣٠-٢٠
٠,٠٤٠	٠,١٠	٠,٠٣١	٠,٠٨	١,٥٧٤٨-١,١٨١١	٤٠-٣٠
٠,٠٤٧	٠,١٢	٠,٠٤٠	٠,١٠	١,٩٦٨٥-١,٥٧٤٨	٥٠-٤٠
٠,٠٥٥	٠,١٤	٠,٠٤٧	٠,١٢	٢,٣٦٢٢-١,٩٦٨٥	٦٠-٥٠
٠,٠٦٣	٠,١٦	٠,٠٥٥	٠,١٤	٢,٧٥٥٩-٢,٣٦٢٢	٧٠-٦٠

### الطلبات

إذا كنت بحاجة إلى قياس آخر غير مدرج في القائمة، يُرجى سؤال مسؤول الاتصال. يمكن حسب الطلب تصنيع أي قياس مدرج في غضون ١٤ أسبوع.

للتمكن من تقديم مجموعة كاملة لك، يتم استكمال باقتنا بصفة منتظمة بطرازات جديدة. يُرجى سؤال مسؤول الاتصال. وسوف يخبرك بالوضع الحالي. خامات الصمامات ومجاري الصمامات متوائمة مع حلقات المقاعد وتضمن تشغيلاً مثاليًا.

أجزاء مخروط الحزوز LK

الوزن (جم)	قياس طرف عمود الصمام قطر D1	قياس طرف عمود الصمام		قطر القياس الاسمي D	قطر $\pm 0.06$	الوصف المختصر التوصيل	غير مصد
		قطر النطاق المفضل D	من إلى				
٠,٥٨	٠,٠٥ ± ٤,٣٥	٥,٣٩	٥,٤٩	٥,٥	٨,٥	LK 5.5H	LK 5.5
٠,٦٤	٠,٠٥ ± ٤,٨٥	٥,٨٩	٥,٩٩	٦	٩	LK 6H	LK 6
٠,٦٩	٠,٠٥ ± ٥,٣٥	٦,٣٩	٦,٤٩	٦,٥	٩,٥	LK 6.5H	LK 6.5
٠,٧٣	٠,٠٥ ± ٥,٨٥	٦,٨٩	٦,٩٩	٧	١٠	LK 7H	LK 7

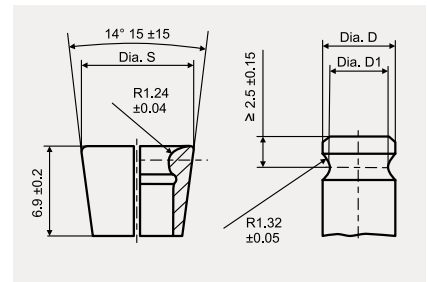

أجزاء مخروط الحزوز LK، مخروط ١:٤

أجزاء مخروط الحزوز RK

الوزن (جم)	قياس طرف عمود الصمام قطر D1	قياس طرف عمود الصمام		قطر القياس الاسمي D	قطر $\pm S$	الوصف المختصر التوصيل	غير مصد
		قطر النطاق المفضل D	من إلى				
٠,٧٧	٠,٠٥ ± ٤,١٥	٥,٨٩	٥,٩٩	٦	٨,٧٩	RK 6H	RK 6
٠,٩١	٠,٠٥ ± ٥,١٥	٦,٨٩	٦,٩٩	٧	٩,٧٩	RK 7H	RK 7
١,٠٩	٠,٠٧ ± ٦,١٣	٧,٨٩	٧,٩٩	٨	١٠,٧٩	RK 8H	RK 8
١,١٩	٠,١ ± ٧,١	٨,٨٩	٨,٩٩	٩	١١,٧٩	RK 9H	RK 9
١,٣٠	٠,١ ± ٨,١	٩,٨٩	٩,٩٩	١٠	١٢,٧٩	RK 10H	RK 10
١,٤٦	٠,١ ± ٩,١	١٠,٨٩	١٠,٩٩	١١	١٣,٧٩	RK 11H	RK 11
١,٥٨	٠,١ ± ١٠,١	١١,٨٩	١١,٩٩	١٢	١٤,٧٩	RK 12H	RK 12

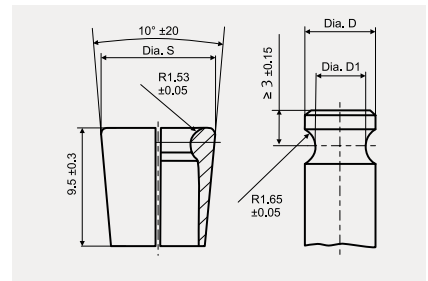

أجزاء مخروط الحزوز RK، مخروط ١:٤

جزء المخروط متعدد الحزوز MK 5-6

الوزن (جم)	قطر $\pm S$	قطر D1	قطر $\pm D$	عدد التتوعات	الطرز
٠,٣٠	٧,٠	٠,٠٥ ± ٣,٩١	٤,٩٢	٣	MK 5
٠,٣٥	٧,٥	٠,٠٥ ± ٤,٤١	٥,٤٢	٣	MK 5.5
٠,٤٩	٨,٥	٠,٠٥ ± ٤,٥٩	٥,٩٢	٣	MK 6
١,١٢	١٠,٥	٠,٠٥ ± ٥,٢٥	٦,٩٢	٣	MK 7
١,٢٧	١١,٥	٠,٠٧ ± ٦,٢٣	٧,٩٢	٣	MK 8
١,٤٠	١٢,٥	٠,١ ± ٧,٢٠	٨,٩٢	٣	MK 9

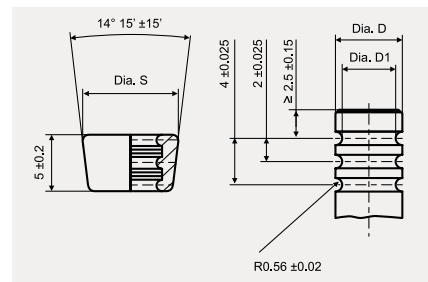

جزء المخروط متعدد الحزوز MK 5-6، مخروط ١:٤

جزء المخروط متعدد الحزوز MK 10-12

الوزن (جم)	قطر $\pm S$	قطر D1	قطر $\pm D$	عدد التتوعات	الطرز
٢,٠٤	١٣,٨	٠,١ ± ٨,٢٠	٩,٩٢	٤	MK 10
٢,١٩	١٤,٨	٠,١ ± ٩,٢٠	١٠,٩٢	٤	MK 11
٢,٨٢	١٥,٨	٠,١ ± ١٠,٢٠	١١,٩٢	٤	MK 12

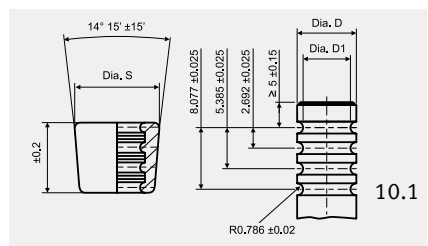

جزء المخروط متعدد الحزوز MK 10-12، مخروط ١:٤

### ٣- أجزاء مخروط الصمام – الطرازات والقياسات

الخامة	الوصف	التصميم	قطر عمود الصمام	التصليد	عدد الحزوز
KK-6H	جزء المخروط أحادي الحزوز	لاصق	٦	مصلد	١
KK-7H	جزء المخروط أحادي الحزوز	لاصق	٧	مصلد	١
KK-8H	جزء المخروط أحادي الحزوز	لاصق	٨	مصلد	١
KK-9H	جزء المخروط أحادي الحزوز	لاصق	٩	مصلد	١
KK-10H	جزء المخروط أحادي الحزوز	لاصق	١٠	مصلد	١
KK-11H	جزء المخروط أحادي الحزوز	لاصق	١٠	مصلد	١
KK-12H	جزء المخروط أحادي الحزوز	لاصق	١٢	مصلد	١
LK-5H	جزء المخروط أحادي الحزوز	لاصق	٥	مصلد	١
LK-5.5H	جزء المخروط أحادي الحزوز	لاصق	٥,٥	مصلد	١
LK-6H	جزء المخروط أحادي الحزوز	لاصق	٦	مصلد	١
LK-7H	جزء المخروط أحادي الحزوز	لاصق	٧	مصلد	١
LK-1610	جزء المخروط أحادي الحزوز	لاصق	١٢	غير مصلد	١
LK-2607	جزء المخروط أحادي الحزوز	لاصق	٧	مصلد	١
LK-2615	جزء المخروط أحادي الحزوز	لاصق	٩	غير مصلد	١
MK-5H	جزء المخروط متعدد الحزوز	غير لاصق	٥	مصلد	٣
MK-5.5H	جزء المخروط متعدد الحزوز	غير لاصق	٥,٥	مصلد	٣
MK-6H	جزء المخروط متعدد الحزوز	غير لاصق	٦	مصلد	٣
MK-7H	جزء المخروط متعدد الحزوز	غير لاصق	٧	مصلد	٣
MK-7H2	جزء المخروط متعدد الحزوز	غير لاصق	٧	مصلد	٢
MK-8H	جزء المخروط متعدد الحزوز	غير لاصق	٨	مصلد	٣
MK-9H	جزء المخروط متعدد الحزوز	غير لاصق	٩	مصلد	٣
MK-10H	جزء المخروط متعدد الحزوز	غير لاصق	١٠	مصلد	٤
MK-12H	جزء المخروط متعدد الحزوز	غير لاصق	١٢	مصلد	٤
RK-7	جزء المخروط أحادي الحزوز	لاصق	٧	غير مصلد	١
RK-7H	جزء المخروط أحادي الحزوز	لاصق	٧	مصلد	١
RK-8	جزء المخروط أحادي الحزوز	لاصق	٨	غير مصلد	١
RK-8H	جزء المخروط أحادي الحزوز	لاصق	٨	مصلد	١
RK-9H	جزء المخروط أحادي الحزوز	لاصق	٩	مصلد	١
RK-10H	جزء المخروط أحادي الحزوز	لاصق	١٠	مصلد	١
RK-11H	جزء المخروط أحادي الحزوز	لاصق	١١	مصلد	١
RK-9.5H	جزء المخروط أحادي الحزوز	لاصق	٩,٥	مصلد	١

#### أجزاء مخروط الحزوز KK

الوزن (جم)	قياس طرف عمود الصمام		قطر القياس الاسمي D	قطر S ± 0,06	الوصف المختصر	
	قطر D1	قطر النطاق المفضل D إلى من			التصليد	غير مصلد
١,١٧	٠,٠٥ ± ٤,٨٥	٥,٨٩	٥,٩٩	٦	١٠	KK 6H / KK 6
١,٣٧	٠,٠٥ ± ٥,٨٥	٦,٨٩	٦,٩٩	٧	١١	KK 7H / KK 7
١,٥٥	٠,٠٧ ± ٦,٨٣	٧,٨٩	٧,٩٩	٨	١٢	KK 8H / KK 8
١,٧٣	٠,١ ± ٧,٨	٨,٨٩	٨,٩٩	٩	١٣	KK 9H / KK 9
١,٩٠	٠,١ ± ٨,٨	٩,٨٩	٩,٩٩	١٠	١٤	KK 10H / KK 10
٢,٠٠	٠,١ ± ٩,٨	١٠,٨٩	١٠,٩٩	١١	١٥	KK 11H / KK 11
٢,٢٤	٠,١ ± ١٠,٨	١١,٨٩	١١,٩٩	١٢	١٦	KK 12H / KK 12

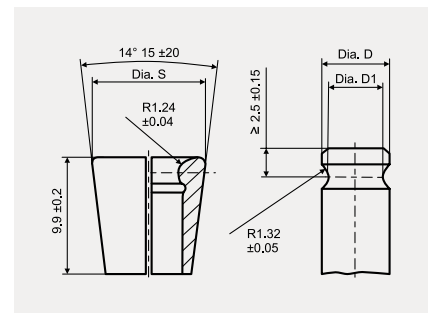

أجزاء مخروط الحزوز KK، مخروط ٤:١



رج ابلق عارذ

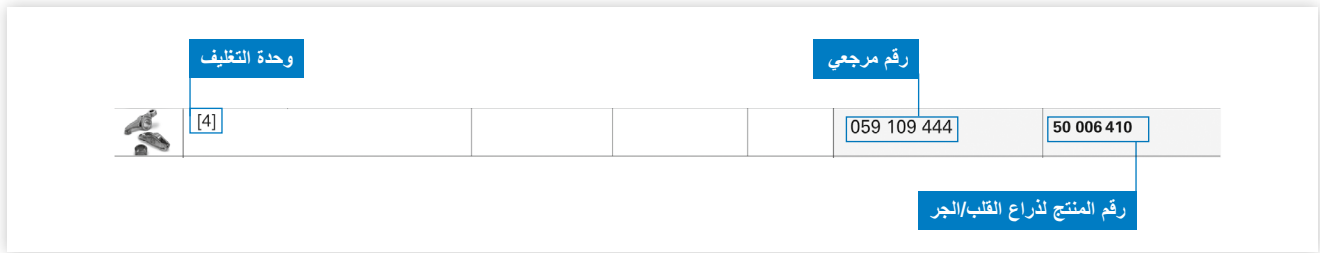

قن او طس أل س أر

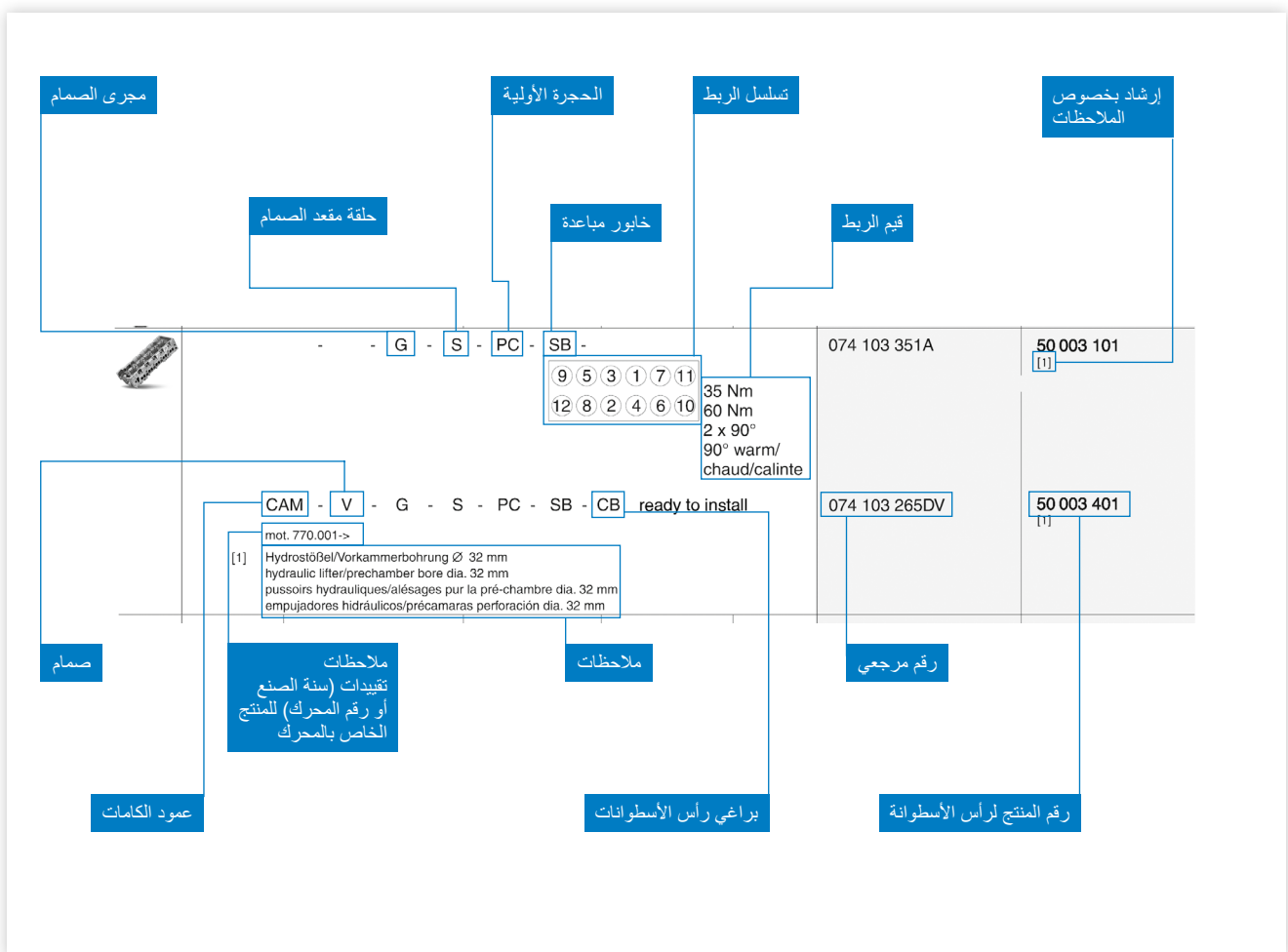

دامصلا دعقم تناقلح

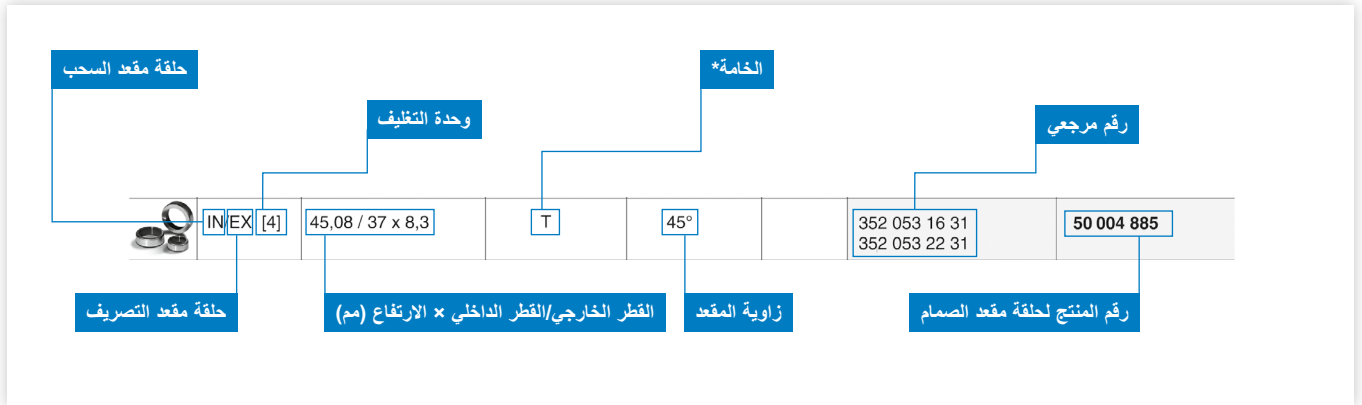

تامالكلا قديمأ

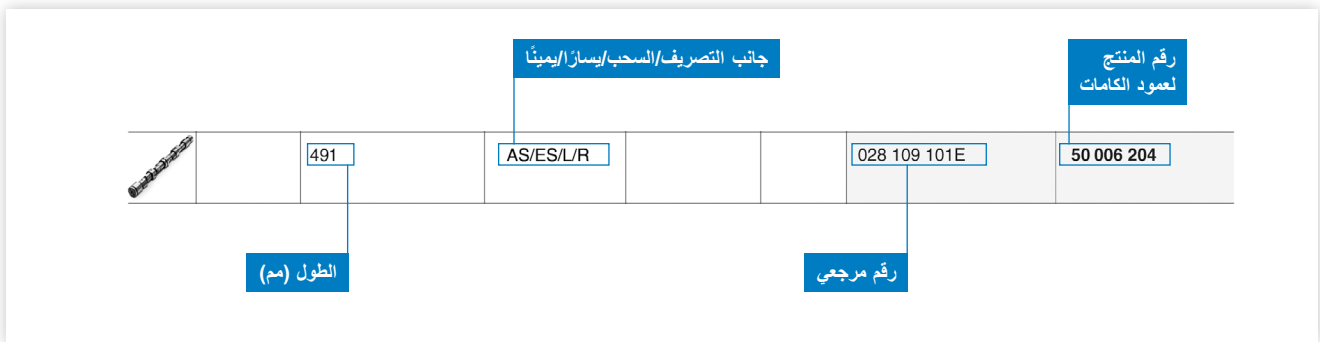

عندلا عارذ

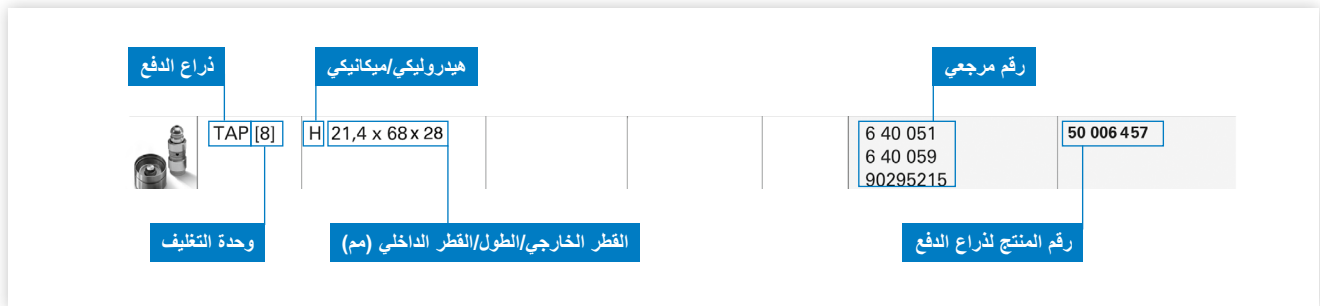

تامامصلًا

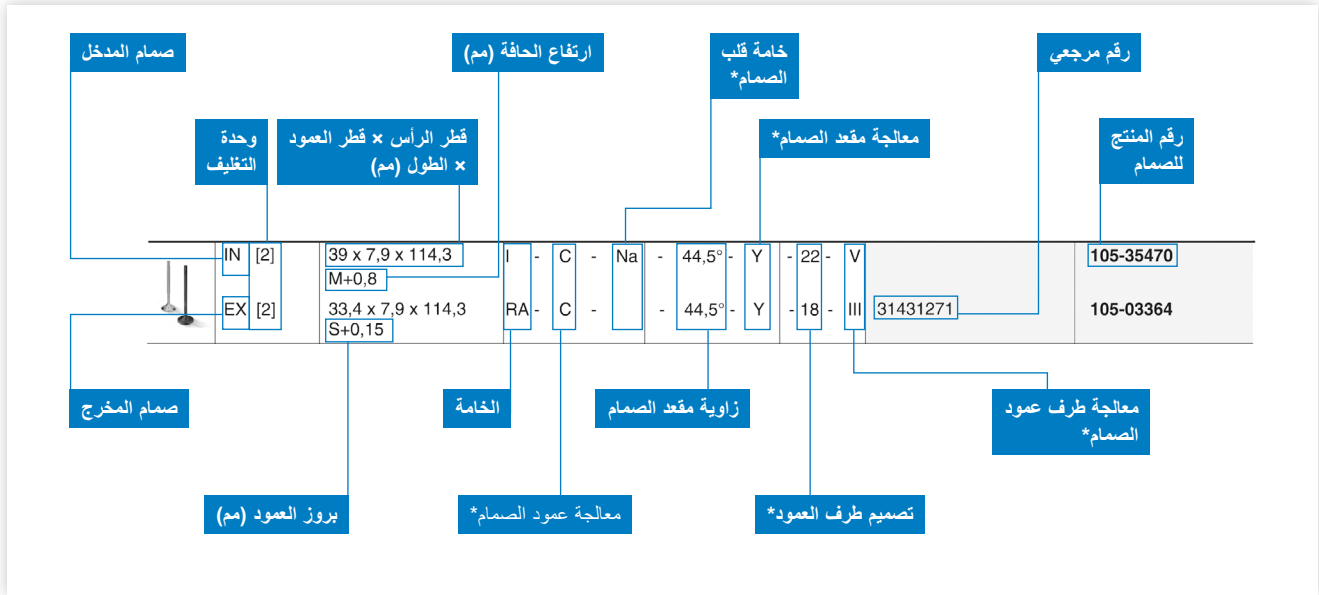

تامامصلًا مقول



تامامصلًا يراجم

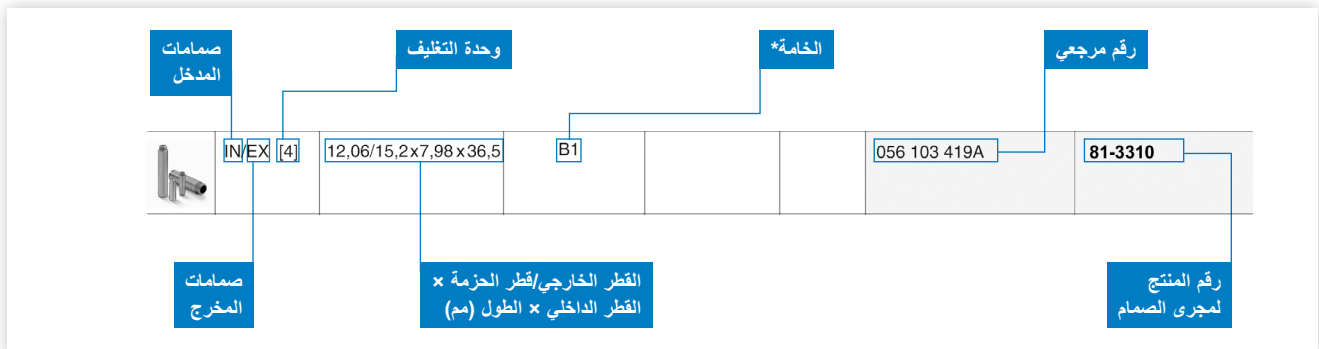

انظر فهرس الاختصارات

جتنر المان ايب

تتكون صفحات الكتالوج من مجموعة المعلومات المذكورة لاحقاً:

لقم الصمامات

صف الرسم الصوري

خانة الجهة المنتجة

رقم الموضع

سطر المحرك

الصمامات

ةجتنر المان ايب

<b>24</b>	<b>115 Cyl. 6</b>																				
D 5TC EURO 1		03.1988 -> 04.1994		D [AN]	6	7800 cm3	2V	178 kW (242 PS)	16:1	125 mm [1]											
[1] Conrod length = 220 mm		mot. -> 456789																			
94 347 6.																					
	IN [2]	39 x 7,9 x 114,3 M+0,8	I - C - Na	- 44,5° - Y	- 22 - V					105-35470											
	EX [2]	33,4 x 7,9 x 114,3 S+0,15	RA - C -	- 44,5° - Y	- 18 - III	31431271				105-03364											
	[50]	8				12345678				KK-8											
	IN/EX [4]	12,06/15,2x7,98x36,5	B1			056 103 419A				81-3310											
	IN/EX [4]	45,08 / 37 x 8,3	T	45°		352 053 16 31 352 053 22 31				50 004 885											
		491	AS/ES/L/R			028 109 101E				50 006 204											
	TAP [8]	H 21,4 x 68 x 28				6 40 051 6 40 059 90295215				50 006 457											
	[4]					059 109 444				50 006 410											
			- - G - S - PC - SB -			074 103 351A				50 003 101 [1]											
				<table border="1" style="font-size: small;"> <tr><td>9</td><td>5</td><td>3</td><td>1</td><td>7</td><td>11</td></tr> <tr><td>12</td><td>8</td><td>2</td><td>4</td><td>6</td><td>10</td></tr> </table>	9	5	3	1	7	11	12	8	2	4	6	10	35 Nm 60 Nm 2 x 90° 90° warm/ chaud/calinte				
9	5	3	1	7	11																
12	8	2	4	6	10																
			CAM - V - G - S - PC - SB - CB	ready to install		074 103 265DV				50 003 401 [1]											
		mot. 770.001->																			
		[1] Hydrostößel/Vorkammerbohrung Ø 32 mm hydraulic lifter/prechamber bore dia. 32 mm poussoirs hydrauliques/alésages pur la pré-chambre dia. 32 mm empujadores hidráulicos/précamaras perforación dia. 32 mm																			

حلقات مقعد الصمام

ملاحظات

رأس الأسطوانة

ذراع الدفع

مجاري الصمامات

ذراع قلب/جر

أعمدة الكامات

انظر فهرس الاختصارات



كبح حمل الرطس

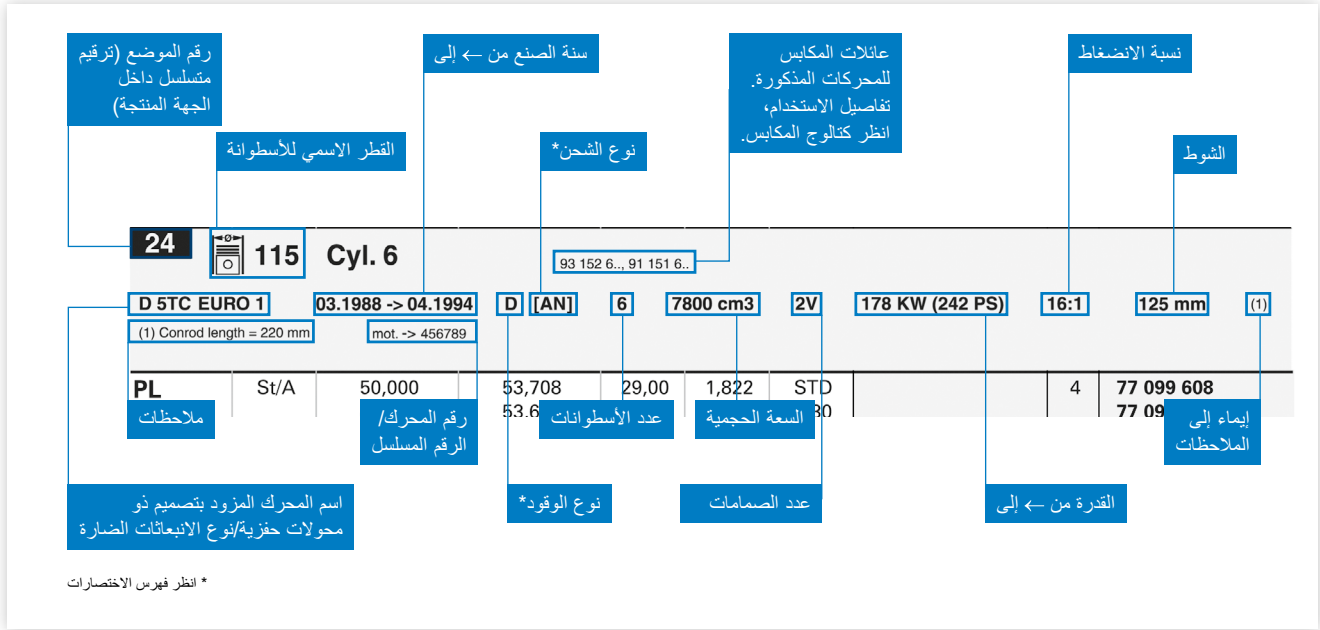

## ٢- إرشادات حول استخدام الكتالوج

### لمحرك ليد

لماش شحب رشوم دجوي نين عملما هجت عملما هه جلا هيا دب عم يدعاصرت لكش ب اي دجبا تا لفر عملما عامسا دبي تيرت مت

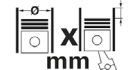





KOLBENSCHMIDT		DEUTZ						
INDEX								
	Cyl.	 mm	cm <sup>3</sup>	Comp. Ratio	ε	kW	PS	Pos
A 6 M 816	D (AN) 6	142 x 160	15204	2	16:1	145-172	197-234	45
A 6 M 816 R	D (LA) 6	142 x 160	15204	2	16:1			45
A 6 M 816 U	D (LA) 6	142 x 160	15204	2	16:1			45
A 6 M 816 W	D (LA) 6	142 x 160	15204	2	16:1			45

المحرك

رقم الموضوع

### مؤشر السيارة

تجد مساعدة بحث تفصيلية عند بداية الشركة الصانعة المعنية. ويتم تصنيف السيارات بأرقام تصاعدية.

KOLBENSCHMIDT		AUDI						
INDEX								
 		Pos	 		Pos			
A1 (8X)			A4 1.8i Turbo 20V	01.1999 → 06.2000	ANB	B	23	
1.4 TFSI	05.2010 →	CAXA B	3	A4 1.8i Turbo 20V	06.2000 → 09.2001	AWT	B	27
2.0 TDI	09.2011 →	CFHB D	33	A4 1.9 TDI	01.1995 → 07.1996	1Z	D	11
A2 (8Z)				A4 1.9 TDI	03.1996 → 07.1999	AFN	D	11

السيارة/سلسلة الطرازات

رقم الموضوع

## عناصر التحكم

## وصلة مصممة

يمكن أن يتحقق نقل الحركة الموثوق والدقيق بين عمود الكامات ورأس الأسطوانة فقط من خلال عناصر التحكم عالية القيمة. تضمن عناصر التحكم من Motorservice الدقة والعمر الطويل لوحدة التحكم في الصمامات بأكملها.



## الغماز الهيدروليكي

## لا يحتاج للصيانة، موازنة أوتوماتيكية

من خلال تصميم الغماز الهيدروليكي لا يكون هناك حاجة للفحص وإعادة الضبط للخلوص ونقل وفقاً لذلك تكاليف الصيانة الطائلة. الغمازات الهيدروليكية تعمل بدون خلوص تقريباً – وهذا يقلل التآكل المرتبط بالتشغيل ويؤثر بشكل مناسب على هدوء التشغيل ودرجة التأثير للمحركات.



## رؤوس الأسطوانات

## صُممت من أجلك بحسب الاحتياج

يتوفر لدى شركة Motorservice باقة منتجات مختارة من رؤوس الأسطوانات لسيارات الركوب والمركبات التجارية. تتوافر رؤوس الأسطوانات حسب الحاجة وبشكل سهل الإصلاح مع صمامات ونوابض صمامات مسبقة التركيب.



تجد المعلومات الفنية حول المنتجات، والتركيب والتليين في  
[www.ms-motorservice.com](http://www.ms-motorservice.com)









# ١- مكونات الصمامات ورؤوس الأسطوانات

## مجري الصمامات مجرى على مستوى عالٍ

في ظل الظروف الشاقة يضع مجرى الصمام الصمام في منتصف حلقة مقعد الصمام ويوجه أيضًا جزء من السخونة إلى رأس الأسطوانة. وتمثل الخامة وخصائصها عاملاً حاسماً في ظل هذه التحميلات الشاقة – لا تغامر بسلامتك واعتمد على جودة منتجات TRW Engine Components.



## الصمامات

جودة وأمان لكيلومترات عديدة

تتعرض الصمامات خلال فترة تشغيل تبلغ ٢٠٠,٠٠٠ كم لحوالي ٢٠٠ مليون تغير في الحمل. لهذا السبب تم تصميم صمامات TRW Engine Components على أساس طرق الاحتساب الحديثة (FEA) وقد خضعت للعديد من الاختبارات قبل السماح بالإنتاج القياسي.



## أعمدة الكامات

كامات مقاومة للتآكل من أجل محركات ذات عمر طويل،

### وأداء قوي

للسيطرة على إجهادات الانثناء والالتواء العالية على المدى الطويل، تبين أعمدة الكامات من مجموعة توريدات شركة Motorservice معدلات مقاومة عالية. وفقاً للغرض التشغيل يتم صب أعمدة الكامات أو تشكيلها بالطرق.

## حلقات مقعد الصمام

الخامة المناسبة لكل استخدام

بالكاد يمكن إتمام الإجهاد الحراري والميكانيكي المرتفع على نحو متزايد بحلقة المقعد في المحركات الحديثة باستخدام خامات مصنوعة من طرق الصب التقليدية. لهذا السبب توفر Motorservice بجانب حلقات مقعد الصب أيضًا حلقات مقعد صمام ملبدة من ثلاث تشكيلات خامات مختلفة.









## نقل المعرفة الفنية المتخصصة المعرفة الفنية المتخصصة للخبير

### دورات تدريب في جميع أنحاء العالم من الجهة الصانعة مباشرة

يوجد حوالي ٤٥٠٠ ميكانيكي وفني يستفيدون سنويًا من الدورات التدريبية والسيمنارات التي نعددها في موقعك في جميع أنحاء العالم أو في مراكزنا التدريبية في نويشتاد ودورماجن وتام (ألمانيا).

### معلومات فنية

#### من رحم التدريب العملي لواقع التدريب العملي

من خلال ما نوفره من معلومات للمنتج ومعلومات الخدمة والكتيبات والملصقات الفنية فسوف تكون دائمًا مواكبًا لأحدث مستوى معرفي في المجال التقني.

### مقاطع فيديو فنية

#### نقل المعرفة عن طريق الفيديو

ستجد في مقاطع الفيديو التي نقدمها إرشادات تركيبية عملية وشروحات خاصة بنظم منتجاتنا.

### YouTube

### البوابة مسلطة على المنتجات أونلاين

#### حلولنا موضحة بشكل مرئي

من خلال العناصر التفاعلية والصور المتحركة ومقاطع الفيديو يمكنك الاستعلام عن منتجاتنا سواء التي في المحرك أو في نطاقه.

### متجر أونلاين

#### طريقك المباشر لمنتجاتنا

يمكنك الطلب على مدار الساعة. الفحص السريع للتوفرية. البحث الشامل عن المنتجات من خلال المحرك والمركبة والأبعاد وما إلى ذلك.

### أخبار

#### معلومات دورية عن طريق البريد الإلكتروني

قم الآن بتسجيل اشتراكك أونلاين في صحيفتنا المجانية وستحصل على معلومات دورية خاصة بمستجدات المنتجات والمنشورات الفنية وغيرها الكثير.

### معلومات فردية

#### مخصصة لعملائنا

سوف نقدم لك معلومات وخدمات شاملة متعلقة بنطاق معدلات أداتنا العريض: مثلاً خامات تعزيز البيع المتوائمة مع المتطلبات الشخصية ووسائل دعم البيع والدعم الفني وغيرها الكثير.



### الموسوعة الفنية

#### معلومات فنية خاصة بالمحرك

في موسوعتنا الفنية سوف نتشارك معك معرفتنا الفنية المتخصصة. سوف تجد هنا المعرفة الفنية المتخصصة مباشرة من الخبراء.

### تطبيق خدمة المحرك

#### إمكانية وصول جواله للمعرفة الفنية المتخصصة

سوف تحصل هنا بسرعة وسهولة على أحدث مستوى للمعلومات والخدمات بشأن منتجاتنا.

### الوسائط الاجتماعية

#### دائمًا محدثة





صفحة	فهرس المحتويات
١٠٧	إرشادات مهمة
١٠٦	إدارة الجودة
١٠٥	نقل الخبرة الفنية – الدراية الفنية للخبراء
١٠٢	١- مكونات الصمامات ورووس الأسطوانات
٩٩	٢- إرشادات حول استخدام الكتالوج
٩٣	٣- أجزاء مخروط الصمام – الطرازات والقياسات
٩١	٤- توصيات الاستخدام وإرشادات التركيب
١٠٩	٥- قوائم أبعاد حلقات تركيب الصمامات
١١٠	١-٥ تصنيف حسب القطر الخارجي D (مم)
١١٧	٢-٥ تصنيف حسب القطر الخارجي D (بوصة)
١٢٣	٦- استكمال البرنامج
١٣٩	٧- فهرس الجهة المنتجة
١٤١	٨- مجموعة المنتجات
١٤١٩	٩- TRW Engine Components / BF / رقم / Kolbenschmidt – الاستخدامات
١٤٥٧	١٠- قائمة المراجع
	١١- طريقة التصرف في حالة وجود شكوى / صيغة الشكوى

محتويات الكتالوج متوفرة أيضًا في الكتالوج الإلكتروني الخاص بنا أونلاين وفي تطبيقنا وأيضًا على موقع .TECALLIANCE

مزيد من المعلومات:  
[catalog.ms-motorservice.com](http://catalog.ms-motorservice.com)  
 تطبيق [motorservice.app](http://motorservice.app)



**TecDoc®**  
 CERTIFIED DATA SUPPLIER

## مجموعة MOTORSERVICE الجودة والخدمة من مصدر واحد

تعد مجموعة Motorservice شركة مبالاء وسويتلا نشطة ما بعدة بصتمخا معوزيتلا مؤسسة Rheinmetall. شركة مبدت مع ساولا بارغلا عطة قسو ومحركات فلا وفير مكونات في فدنارلا شركاتلا إحدى هو Motorservice تميز تمللا جاري تمللا حل اماتلا مع لفلود قجود لعاة بليصوا قة كبير لشكيت شورلاو تجار تمللا نها منعمل Kolbenschmidt و Pierburg و TRW Engine Components لاضجارية فتلا حل اماتلا ن BF و turbo by Intec.

## RHEINMETALL تقنيات للتقل في المستقبل

بصفتها مورد سيارات على مستوى العالم، تتمتع شركة Rheinmetall بالكفاءة العليا في الأسواق المعنية في مجالات إمداد الهواء، وخفض الانبعاثات الضارة والمضخات وكذلك في تطوير وتصنيع وتوريد قطع غيار المكابس وكتل المحركات والمحامل الانزلاقية. يتم تطوير المنتجات بالتعاون الوثيق مع مصنعي السيارات المعروفين.

## إرشادات مهمة

يتعين دائماً قبل التركيب القيام بالفحص للتحقق مما إذا كان المنتج المعني مناسباً لغرض الاستخدام المقصود. لا يمكن الاطلاع على بياناتنا ومعرفة أي معلومات عن طبيعة معينة أو التحقق من ملاءمة لغرض معين. وبصفة خاصة يرجى مراعاة أن المنتجات المطروحة في الكتالوج ليست مناسبة للاستخدام في المركبات الهوائية أو الفضائية. عند الاستخدام في محركات الطرق الوعرة (مثل المحركات البحرية أو الثابتة أو محركات القطارات) يجب مراعاة أنه حتى في حالة تشابه مسمى المحرك فهناك أجزاء أخرى مختلفة من المحرك (المكابس مثلاً). ولذلك فقد يتعين أيضاً قبل تركيب المنتجات طلب المشورة الفنية المتخصصة من الجهة الصانعة أو الورشة الفنية المعتمدة. وفي هذا الصدد فإننا نشير إلى ضرورة إجراء أعمال التركيب دائماً على يد عمالة فنية متخصصة ومدربة. الصور والرسوم التوضيحية وغيرها من البيانات الأخرى تستخدم للشرح والإيضاح ولا يمكن استخدامها كأساس للتركيب.

لا يُسمح بأي نسخ أو محاكاة أو توزيع أو استنساخ عام لهذا الكتالوج، حتى ولو بشكل جزئي دون الحصول على تصريح كتابي مسبق وأن يكون هناك بيان مصدر يحمل هذا المضمون. إصدار هذا الكتالوج يفقد الإصدارات السابقة صلاحيتها.

كل البيانات الواردة في هذا الكتالوج غير ملزمة. ولا يمكننا تحمل أية مسؤولية عن سلامتها واكتمالها. ويسعدنا دائماً تلقي إخطاراتكم بخصوص أية أخطاء قد ترد في الكتالوج على أن نصححها في الطبعة القادمة.

السماء والتوصيفات وبيانات الأرقام الخاصة بالمركبات أو الجهات المصنعة وما شابه واردة فقط لأغراض المقارنة، تماماً مثل أرقام القطع الأصلية للجهات المصنعة للمركبات والمحركات. مثل هذه البيانات ليست رسوماً أساسية ولا يجوز استخدامها ضد أطراف أخرى. يرجى في هذا الإطار مراعاة أنه يمكن إدخال تغييرات على التجهيزات من قبل الشركات الصانعة للسيارات والمحركات أو قد تطرأ تغييرات على المسميات. ولذلك فلا يمكننا تحمل أية مسؤولية عن استخدام قوائم المقارنة.

نحن نحفظ صراحة بحق إدخال تغييرات على مواصفات المنتجات والخامات والمظهر الخارجي ونطاق توريد منتجاتنا في أي وقت. ولذلك فإن الأشكال الواردة في الكتالوج ليست ملزمة.

## شهادات الاعتماد

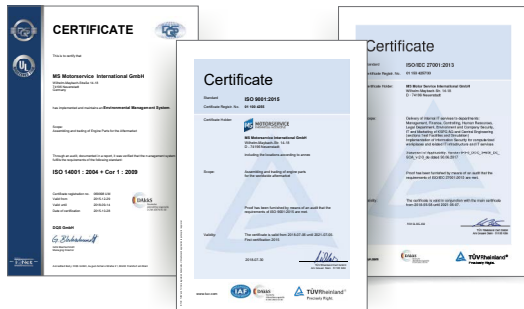

شركة MS Motorservice International GmbH مزودة بنظام إدارة الجودة معتمد طبقاً للمواصفة ISO 9001 ونظام إدارة البيئة معتمد وفقاً للمواصفة ISO 14001.

AR

نقاط أساسية

**D****VENTILSITZRINGE**

---

**E****VALVE SEAT INSERTS**

---

**F****BAGUES DE SIÈGE DE SOUPAPE**

---

**ES****INSERTOS DE ASIENTO DE VÁLVULA**

---

**RU****КОЛЬЦА СЕДЛА КЛАПАНА**

---



# VALVE SEAT INSERTS

[mm]			HM	HT	HT+	G1/G2
D	d	h	SEMIFINISHED	SEMIFINISHED	SEMIFINISHED	FINISHED
22,00	19,00	8,00		50 009 624		
24,00	18,00	8,00		50 009 610	50 009 650	
24,10	18,00	6,50		50 009 603		
24,10	18,80	6,50		50 009 602		
25,00	19,00	8,00		50 009 611	50 009 651	
25,12	20,00	6,00	50 004 700			
26,00	20,00	8,00		50 009 612		
26,70	20,00	5,70	50 004 701	50 004 900	50 009 696	
27,00	20,00	8,00			50 009 693	
27,00	21,00	10,00		50 009 613		
27,13	22,10	6,40	50 004 702			
27,15	20,10	6,60	50 004 703			
28,00	22,00	10,00	50 004 811	50 004 932	50 009 652	
28,50	22,00	10,00	50 004 812	50 004 933	50 009 653	
28,70	22,10	4,90	50 004 704			
28,75	21,00	7,20	50 004 705			
28,80	24,00	8,60		50 009 615		
29,00	18,00	10,00		50 009 614	50 009 697	
29,00	23,00	10,00	50 004 813	50 004 934	50 009 654	
29,50	23,00	10,00	50 004 814	50 004 935	50 009 655	
30,00	20,00	10,00	50 004 816	50 004 937	50 009 657	
30,00	23,00	10,00	50 004 815	50 004 936	50 009 656	
30,02	23,50	6,20	50 004 706			
30,15	25,00	6,30	50 004 707	50 004 901		
30,19	24,10	8,10		50 004 920	50 009 658	
30,30	23,70	6,40	50 004 708			
30,31	22,10	6,40	50 004 709			
30,33	23,70	6,60	50 004 710			
30,50	23,00	10,00	50 004 817	50 004 938	50 009 659	
30,50	25,00	6,50	50 004 711			
31,00	18,00	7,50			50 009 623	
31,00	21,00	10,00	50 004 819	50 004 940	50 009 661	
31,00	24,00	10,00	50 004 818	50 004 939	50 009 660	
31,50	24,00	10,00	50 004 820	50 004 941	50 009 662	
31,83	27,40	8,50		50 004 921	50 009 698	
31,88	25,40	6,40	50 004 713			
31,88	26,80	6,40	50 004 712			
31,90	23,70	6,40	50 004 714			
31,90	25,30	6,40	50 004 715			
31,93	23,10	7,20	50 004 716			
32,00	22,00	10,00	50 004 822	50 004 943	50 009 665	
32,00	24,00	9,00		50 004 928	50 009 663	
32,00	25,00	10,00	50 004 821	50 004 942	50 009 664	
32,33	27,40	8,50		50 009 600		
32,50	25,00	10,00	50 004 823	50 004 944	50 009 666	
32,65	25,50	8,00	50 004 717			
32,65	26,00	8,50	50 004 718			
32,80	28,50	8,80		50 009 616		
32,83	27,40	8,50		50 009 601		
33,00	23,00	10,00	50 004 825	50 004 946	50 009 668	
33,00	25,00	4,50	50 004 796			
33,00	25,00	8,50	50 004 719			
33,00	26,00	10,00	50 004 824	50 004 945	50 009 667	
33,47	25,40	6,40	50 004 720			
33,48	25,30	6,40	50 004 721			
33,48	26,90	6,40	50 004 722			
33,50	24,80	7,10	50 004 724			
33,50	26,00	10,00	50 004 826	50 004 947	50 009 669	
33,50	26,50	8,00	50 004 723			
33,50	27,00	9,00	50 004 805			
33,70	27,00	8,00	50 004 725	50 004 902	50 009 699	
33,70	28,60	6,40	50 004 726	50 004 903		
34,00	24,00	10,00	50 004 827	50 004 949	50 009 671	

# VALVE SEAT INSERTS

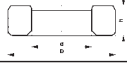

**[mm]**

<b>D</b>	<b>d</b>	<b>h</b>	<b>HM</b> SEMIFINISHED	<b>HT</b> SEMIFINISHED	<b>HT+</b> SEMIFINISHED	<b>G1/G2</b> FINISHED
34,00	26,00	8,50	50 004 727			
34,00	27,00	10,00	50 004 801	50 004 948	50 009 670	
34,25	27,00	8,00	50 004 728			
34,50	27,00	10,00	50 004 828	50 004 950	50 009 672	
34,70	28,30	7,50	50 004 729			
34,76	32,10	7,80				92-22016
34,91	29,50	5,80				92-17001
34,91	29,60	5,80				92-17000
35,00	25,00	10,00	50 004 830	50 004 952	50 009 674	
35,00	28,00	10,00	50 004 829	50 004 951	50 009 673	
35,00	28,50	7,90	50 004 730			
35,05	27,00	6,40	50 004 731			
35,07	26,90	6,40	50 004 732			
35,07	28,50	6,40	50 004 733			
35,08	28,00	7,65				92-16165
35,10	25,40	7,10	50 004 735			
35,10	25,40	10,40	50 004 734			
35,25	28,00	8,00	50 004 736			
35,37	28,00	7,70				92-16159
35,50	28,00	10,00	50 004 831	50 004 953	50 009 500	
35,50	29,00	10,00	50 004 802			
35,50	29,50	9,50	50 004 806			
35,60	29,00	8,00	50 004 737			
35,90	29,70	7,90				92-22015
36,00	26,00	10,00	50 004 833	50 004 955	50 009 676	
36,00	29,00	10,00	50 004 832	50 004 954	50 009 675	
36,12	29,30	8,00	50 004 738			
36,50	29,00	10,00	50 004 834	50 004 956	50 009 677	
36,59	30,10	7,90	50 004 739			
36,64	28,60	6,40	50 004 740			
36,64	28,60	8,00	50 004 741			
36,66	26,90	6,40	50 004 742			
36,68	31,20	6,40	50 004 743			
36,80	28,40	7,50				92-22020
37,00	28,00	9,00	50 004 744			
37,00	30,00	8,00	50 004 745	50 004 904		
37,00	30,00	10,00	50 004 835	50 004 957	50 009 678	
37,00	31,00	10,00	50 004 803			
37,01	30,15	7,55				92-22008
37,03	27,90	9,00	50 004 746			
37,07	28,60	7,20				92-22011
37,08	30,56	7,00				92-16124
37,20	30,00	7,00	50 004 747	50 004 905		
37,50	30,00	10,00	50 004 836	50 004 958	50 009 501	
37,50	31,00	8,50	50 004 748			
37,50	31,20	6,95		50 009 617		
37,59	30,50	7,30				92-16125
38,00	28,00	10,00	50 004 837	50 004 960	50 009 680	
38,00	30,00	7,00	50 004 749	50 004 906		
38,00	31,00	10,00	50 004 804	50 004 959	50 009 679	
38,07	30,00	7,90				92-16154
38,07	30,00	8,50				92-16109
38,10	30,20	6,40	50 004 797			
38,21	28,60	6,40	50 004 750			
38,23	28,60	6,40	50 004 753			
38,23	31,00	8,00	50 004 755	50 004 907	50 009 503	
38,23	31,80	9,50	50 004 754			
38,25	30,10	6,40	50 004 751			
38,25	31,70	6,40	50 004 752			
38,28	27,90	8,00	50 004 756			
38,38	30,00	8,50				92-16131
38,50	31,00	10,00	50 004 838	50 004 961	50 009 504	
38,95	31,00	8,50	50 004 757	50 004 908		

# VALVE SEAT INSERTS

[mm]			HM	HT	HT+	G1/G2
D	d	h	SEMIFINISHED	SEMIFINISHED	SEMIFINISHED	FINISHED
39,00	29,00	10,00	50 004 840	50 004 963		
39,00	32,00	10,00	50 004 839	50 004 962	50 009 681	
39,30	31,20	7,50				92-22019
39,30	32,00	8,00	50 004 758			
39,50	32,00	10,00	50 004 841	50 004 964		
39,50	33,00	8,50	50 004 759			
39,60	33,50	9,50	50 004 807			
39,70	31,80	6,40	50 004 798			
39,77	30,10	9,50	50 004 760			
39,81	31,80	6,40	50 004 761			
39,83	30,10	6,40	50 004 763			
39,85	30,00	7,70	50 004 765			
39,85	31,20	7,90	50 004 764			
39,85	33,00	6,50	50 004 766			
39,98	30,10	7,40				92-22014
40,00	29,00	10,00	50 004 843	50 004 966	50 009 682	
40,00	31,20	6,40				
40,00	32,00	10,00	50 004 842	50 004 965	50 009 506	
40,00	33,00	8,00				92-25016
40,00	33,50	9,00	50 004 808			
40,04	30,95	7,60				
40,04	31,00	7,30				92-59003
40,04	31,20	6,40				92-59001
40,05	31,00	7,40				92-47023
40,08	31,00	8,00				92-16167
40,08	31,20	8,05				92-16166
40,09	33,50	7,00				92-16120
40,10	31,00	7,50				92-16118
						92-16110
40,14	33,00	8,00			50 009 694	
40,16	31,00	9,75				92-22003
40,19	29,97	10,50		50 004 909		
40,19	30,00	10,50	50 004 767			
40,20	34,00	7,50	50 004 768	50 004 910		
40,26	31,00	7,50				92-16141
						92-16146
40,26	31,00	9,75				92-22004
40,38	31,00	8,50				92-16160
40,46	31,00	7,50				92-16143
40,50	32,00	10,00	50 004 844	50 004 967	50 009 507	
40,58	33,50	7,30				92-16121
41,00	30,00	10,00	50 004 846	50 004 969	50 009 508	
41,00	33,00	10,00	50 004 845	50 004 968	50 009 683	
41,00	34,00	7,50	50 004 769	50 004 911		
41,05	30,50	6,15			92-12005	
41,05	31,00	7,40				92-47024
41,28	33,40	6,40	50 004 799			
41,40	31,80	6,40	50 004 770			
41,40	31,80	9,50	50 004 771			
41,50	33,00	10,00	50 004 847	50 004 970	50 009 684	
41,62	34,00	8,00	50 004 772	50 004 912		
42,00	31,00	10,00	50 004 849	50 004 972	50 009 510	
42,00	32,40	8,00				92-25015
42,00	33,00	7,30				
42,00	34,00	10,00	50 004 848	50 004 971	50 009 511	
42,04	33,00	7,35				92-59000
42,05	32,70	8,64				92-47022
42,14	33,00	8,00			50 009 695	
42,20	33,50	10,50	50 004 773			
42,50	34,00	10,00	50 004 850	50 004 973		
42,67	34,18	7,30				92-22012
42,78	33,70	6,85				92-22007
42,98	33,30	8,00	50 004 775			

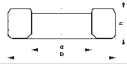
# VALVE SEAT INSERTS

**[mm]**

<b>D</b>	<b>d</b>	<b>h</b>	<b>HM</b> SEMIFINISHED	<b>HT</b> SEMIFINISHED	<b>HT+</b> SEMIFINISHED	<b>G1/G2</b> FINISHED
43,00	32,00	10,00	50 004 852	50 004 975	50 009 512	
43,00	35,00	10,00	50 004 851	50 004 974	50 009 513	
43,03	30,50	6,15				92-12001
43,03	33,00	9,10	50 004 776			
43,03	34,70	6,20				92-12000
43,05	32,00	7,25				92-47032
43,05	33,00	7,50				92-47029
43,05	34,70	6,20				92-12004
43,08	31,90	8,50				92-47026
43,08	32,90	8,00				92-47020
43,08	32,90	8,01				92-47027
43,10	32,00	7,25				92-47019
43,10	32,90	8,00				92-47033
43,10	33,00	7,50				92-47035
43,10	34,00	8,00				92-16158
43,10	34,40	7,75				92-16170
43,25	36,00	8,00	50 004 777	50 004 913		
43,33	35,20	6,40		50 004 915		
43,33	35,20	9,00	50 004 778	50 004 914		
43,50	35,00	10,00	50 004 853	50 004 976		
43,60	35,00	7,90				92-22006
43,87	34,50	7,40				92-16155
43,87	34,50	7,80				92-16153
44,00	33,00	10,00	50 004 855	50 004 978	50 009 685	
44,00	36,00	10,00	50 004 854			
44,01	35,00	8,50				92-34003
44,03	33,90	9,50	50 004 779			
44,04	34,50	6,55				
44,04	35,70	7,80				
44,07	35,45	7,10				92-22010
44,08	34,05	9,00				92-47003
44,10	34,90	8,15				92-25023
44,10	35,50	7,80				92-34006
44,10	35,90	7,80				92-25021
44,11	35,00	8,10				92-25011
44,13	35,50	6,95		50 009 618		
44,13	36,00	9,00		50 004 999	50 009 514	
44,17	34,50	7,80				92-16116
44,25	37,00	8,00	50 004 780			
44,28	34,05	9,20				92-47004
44,50	30,00	10,00	50 004 858	50 004 981	50 009 515	
44,50	36,00	10,00	50 004 856	50 004 979	50 009 516	
44,50	36,00	11,00	50 004 857	50 004 980	50 009 517	
44,58	34,90	6,40	50 004 781			
44,58	34,90	8,00	50 004 782			
45,00	34,00	12,00	50 004 860	50 004 983	50 009 687	
45,00	37,00	12,00	50 004 859	50 004 982	50 009 686	
45,05	34,00	7,50				92-47028
45,05	34,70	8,08				
45,05	36,00	7,20				92-22022
45,08	37,00	8,30				92-16112
45,10	34,00	7,50				92-47034
45,37	35,70	7,30	50 004 783	50 004 919		
45,50	37,00	12,00	50 004 861	50 004 984		
45,64	36,00	9,90	50 004 784			
45,66	36,00	10,00				92-22001
45,76	36,00	10,00				92-22002
45,87	37,00	8,20				92-16114
46,00	34,00	12,00	50 004 863	50 004 986	50 009 518	
46,00	36,40	7,90				
46,00	38,00	12,00	50 004 862	50 004 985		
46,01	36,00	10,00				92-16133
46,04	37,30	7,80				



# VALVE SEAT INSERTS

[mm]			HM	HT	HT+	G1/G2
D	d	h	SEMIFINISHED	SEMIFINISHED	SEMIFINISHED	FINISHED
46,05	37,50	8,10				92-47021
46,06	34,70	7,90				92-34002
46,08	34,50	8,90				92-34005
46,08	35,95	6,85				92-22013
46,10	37,30	7,82				92-25020
46,10	37,50	6,17				92-47001
46,11	36,00	10,00				92-16135
46,13	38,00	7,00		50 004 998		
46,15	37,70	6,40	50 004 785			
46,21	36,00	10,00				92-16137
46,30	37,50	6,37				92-47002
46,50	36,50	9,53	50 004 786			
46,50	38,00	12,00	50 004 864	50 004 987		
47,00	36,00	12,00	50 004 866	50 004 989	50 009 688	
47,00	39,00	12,00	50 004 865	50 004 988		
47,16	37,00	8,60		50 004 930		
47,38	40,00	7,70				92-16157
47,39	36,60	7,80				92-16156
47,50	39,00	12,00	50 004 867	50 004 990		
47,57	38,45	6,65				92-22009
47,75	38,10	6,40	50 004 787			
47,75	38,10	9,50	50 004 788	50 004 924		
47,78	41,30	6,40	50 004 789	50 004 925		
47,78	41,30	9,50	50 004 790	50 004 926		
47,80	40,60	6,40	50 004 791			
48,00	37,00	12,00	50 004 870	50 004 993	50 009 519	
48,00	38,00	11,00	50 004 869	50 004 992		
48,00	40,00	12,00	50 004 868	50 004 991		
48,03	37,00	7,00				92-12003
48,03	39,00	7,00				92-12002
48,04	37,50	12,40				
48,05	39,00	6,20				92-22021
48,06	39,50	6,90				92-34004
48,10	38,05	8,00				92-25009
48,10	40,10	8,00				92-25010
49,07	38,50	7,80				92-47039
49,07	39,50	7,80				92-47037
49,08	39,00	7,50				92-22005
49,08	40,00	11,45				92-47013
49,09	40,00	9,45				92-47015
49,18	41,98	11,50				92-22018
49,28	40,00	11,55				92-47014
49,29	40,00	9,65				92-47016
50,07	39,50	7,55				92-47040
50,11	43,00	10,00		50 009 607		
50,31	43,00	10,20		50 009 608		
50,51	43,00	10,40		50 009 609		
50,95	41,30	6,40	50 004 792			
50,95	41,30	8,00	50 004 793			
51,06	37,00	7,50				92-16106
51,10	41,60	7,45				92-25022
51,10	41,70	7,50				92-25012
51,11	40,08	9,55				92-47006
51,26	37,00	7,50				92-16140
51,26	37,05	7,55				92-16145
51,46	37,00	7,50				92-16142
52,00	39,00	10,30				92-34001
52,07	41,90	7,75				92-47038
52,07	42,00	7,60				92-47036
53,09	43,10	9,70	50 004 871			
53,10	43,00	7,45				92-25004
53,11	43,00	8,40				92-16162
53,11	43,00	9,15				92-16126

# VALVE SEAT INSERTS

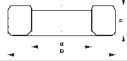

[mm]

D	d	h	HM SEMIFINISHED	HT SEMIFINISHED	HT+ SEMIFINISHED	G1/G2 FINISHED
53,11	43,00	9,20				92-16127
53,11	43,00	9,50				
53,11	43,00	9,70				92-16104
53,11	43,00	9,90				92-25003
53,20	43,00	7,00			50 009 690	
53,31	43,00	9,40				92-16149
53,31	43,00	9,90				92-16148
53,31	43,00	10,10				92-25014
53,51	42,20	9,70				
53,51	43,00	10,20				92-16105
53,51	43,20	9,60				92-16128
53,59	43,10	10,20	50 004 794			
53,70	43,00	10,00			50 009 691	
54,06	44,35	6,68				92-47011
54,10	44,40	6,70				92-47005
54,20	43,00	8,60		50 004 931	50 009 689	
54,20	43,00	10,00		50 004 916	50 009 520	
54,26	44,35	6,88				92-47012
54,65	43,69	10,00			50 009 692	
55,00	44,00	12,00	50 004 800			
55,10	43,00	10,00			50 009 522	
56,00	47,50	7,50				92-34000
56,01	45,00	10,50				92-16132
56,11	45,00	10,50				92-16134
56,17	47,06	11,50				92-22017
56,21	45,00	10,50				92-16136
56,60	44,95	9,45				92-47009
58,30	49,00	6,80				92-47008
59,12	49,00	6,80				92-47007
60,08	49,00	8,00				
60,10	51,00	8,30				92-16161
60,11	49,30	8,40				92-16150
60,11	51,00	8,90		50 009 604		92-16100
60,11	51,20	8,40				92-16122
						92-16151
60,31	51,00	9,10		50 009 605		92-16147
60,31	51,20	8,60				92-16152
60,51	51,00	9,30		50 009 606		92-16101
60,51	51,20	8,90				92-16123
61,11	48,00	8,90				92-25001
61,11	49,00	6,80				92-25005
61,11	49,00	8,80				92-25002
61,11	49,00	8,90				92-25008
61,11	51,00	9,00				92-16163
61,11	51,00	10,40				92-25000
61,51	49,00	9,00				

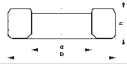

# VALVE SEAT INSERTS

**[inch]**

<b>D</b>	<b>d</b>	<b>h</b>	<b>HM</b> SEMIFINISHED	<b>HT</b> SEMIFINISHED	<b>HT+</b> SEMIFINISHED	<b>G1/G2</b> FINISHED
0,866	0,748	0,314		50 009 624		
0,944	0,708	0,314		50 009 610	50 009 650	
0,948	0,708	0,255		50 009 603		
0,948	0,740	0,255		50 009 602		
0,984	0,748	0,314		50 009 611	50 009 651	
0,988	0,787	0,236	50 004 700			
1,023	0,787	0,314		50 009 612		
1,051	0,787	0,224	50 004 701	50 004 900	50 009 696	
1,062	0,787	0,314			50 009 693	
1,062	0,826	0,393		50 009 613		
1,068	0,870	0,251	50 004 702			
1,068	0,791	0,259	50 004 703			
1,102	0,866	0,393	50 004 811	50 004 932	50 009 652	
1,122	0,866	0,393	50 004 812	50 004 933	50 009 653	
1,129	0,870	0,192	50 004 704			
1,131	0,826	0,283	50 004 705			
1,133	0,944	0,338		50 009 615		
1,141	0,708	0,393		50 009 614	50 009 697	
1,141	0,905	0,393	50 004 813	50 004 934	50 009 654	
1,161	0,905	0,393	50 004 814	50 004 935	50 009 655	
1,181	0,787	0,393	50 004 816	50 004 937	50 009 657	
1,181	0,905	0,393	50 004 815	50 004 936	50 009 656	
1,181	0,925	0,244	50 004 706			
1,187	0,984	0,248	50 004 707	50 004 901		
1,188	0,948	0,318		50 004 920	50 009 658	
1,192	0,933	0,251	50 004 708			
1,193	0,870	0,251	50 004 709			
1,194	0,933	0,259	50 004 710			
1,200	0,905	0,393	50 004 817	50 004 938	50 009 659	
1,200	0,984	0,255	50 004 711			
1,220	0,708	0,295			50 009 623	
1,220	0,826	0,393	50 004 819	50 004 940	50 009 661	
1,220	0,944	0,393	50 004 818	50 004 939	50 009 660	
1,240	0,944	0,393	50 004 820	50 004 941	50 009 662	
1,253	1,078	0,334		50 004 921	50 009 698	
1,255	1,000	0,251	50 004 713			
1,255	1,055	0,251	50 004 712			
1,255	0,933	0,251	50 004 714			
1,255	0,996	0,251	50 004 715			
1,257	0,909	0,283	50 004 716			
1,259	0,866	0,393	50 004 822	50 004 943	50 009 665	
1,259	0,944	0,354		50 004 928	50 009 663	
1,259	0,984	0,393	50 004 821	50 004 942	50 009 664	
1,272	1,078	0,334		50 009 600		
1,279	0,984	0,393	50 004 823	50 004 944	50 009 666	
1,285	1,003	0,314	50 004 717			
1,285	1,023	0,334	50 004 718			
1,291	1,122	0,346		50 009 616		
1,292	1,078	0,334		50 009 601		
1,299	0,905	0,393	50 004 825	50 004 946	50 009 668	
1,299	0,984	0,177	50 004 796			
1,299	0,984	0,334	50 004 719			
1,299	1,023	0,393	50 004 824	50 004 945	50 009 667	
1,317	1,000	0,251	50 004 720			
1,318	0,996	0,251	50 004 721			
1,318	1,059	0,251	50 004 722			
1,318	0,976	0,279	50 004 724			
1,318	1,023	0,393	50 004 826	50 004 947	50 009 669	
1,318	1,043	0,314	50 004 723			
1,318	1,062	0,354	50 004 805			
1,326	1,062	0,314	50 004 725	50 004 902	50 009 699	
1,326	1,125	0,251	50 004 726	50 004 903		
1,338	0,944	0,393	50 004 827	50 004 949	50 009 671	



# VALVE SEAT INSERTS

[inch]			HM	HT	HT+	G1/G2
D	d	h	SEMIFINISHED	SEMIFINISHED	SEMIFINISHED	FINISHED
1,338	1,023	0,334	50 004 727			
1,338	1,062	0,393	50 004 801	50 004 948	50 009 670	
1,348	1,062	0,314	50 004 728			
1,358	1,062	0,393	50 004 828	50 004 950	50 009 672	
1,366	1,114	0,295	50 004 729			
1,368	1,263	0,307				92-22016
1,374	1,161	0,228				92-17001
1,374	1,165	0,228				92-17000
1,377	0,984	0,393	50 004 830	50 004 952	50 009 674	
1,377	1,102	0,393	50 004 829	50 004 951	50 009 673	
1,377	1,122	0,311	50 004 730			
1,379	1,062	0,251	50 004 731			
1,380	1,059	0,251	50 004 732			
1,380	1,122	0,251	50 004 733			
1,380	1,102	0,301				92-16165
1,381	1,000	0,279	50 004 735			
1,381	1,000	0,409	50 004 734			
1,387	1,102	0,314	50 004 736			
1,392	1,102	0,303				92-16159
1,397	1,102	0,393	50 004 831	50 004 953	50 009 500	
1,397	1,141	0,393	50 004 802			
1,397	1,161	0,374	50 004 806			
1,401	1,141	0,314	50 004 737			
1,413	1,169	0,311				92-22015
1,417	1,023	0,393	50 004 833	50 004 955	50 009 676	
1,417	1,141	0,393	50 004 832	50 004 954	50 009 675	
1,422	1,153	0,314	50 004 738			
1,437	1,141	0,393	50 004 834	50 004 956	50 009 677	
1,440	1,185	0,311	50 004 739			
1,442	1,125	0,251	50 004 740			
1,442	1,125	0,314	50 004 741			
1,443	1,059	0,251	50 004 742			
1,444	1,228	0,251	50 004 743			
1,448	1,118	0,295				92-22020
1,456	1,102	0,354	50 004 744			
1,456	1,181	0,314	50 004 745	50 004 904		
1,456	1,181	0,393	50 004 835	50 004 957	50 009 678	
1,456	1,220	0,393	50 004 803			
1,457	1,187	0,297				92-22008
1,457	1,098	0,354	50 004 746			
1,459	1,125	0,283				92-22011
1,459	1,203	0,275				92-16124
1,464	1,181	0,275	50 004 747	50 004 905		
1,476	1,181	0,393	50 004 836	50 004 958	50 009 501	
1,476	1,220	0,334	50 004 748			
1,476	1,228	0,273		50 009 617		
1,479	1,200	0,287				92-16125
1,496	1,102	0,393	50 004 837	50 004 960	50 009 680	
1,496	1,181	0,275	50 004 749	50 004 906		
1,496	1,220	0,393	50 004 804	50 004 959	50 009 679	
1,498	1,181	0,311				92-16154
1,498	1,181	0,334				92-16109
1,500	1,188	0,251	50 004 797			
1,504	1,125	0,251	50 004 750			
1,505	1,125	0,251	50 004 753			
1,505	1,220	0,314	50 004 755	50 004 907	50 009 503	
1,505	1,251	0,374	50 004 754			
1,505	1,185	0,251	50 004 751			
1,505	1,248	0,251	50 004 752			
1,507	1,098	0,314	50 004 756			
1,511	1,181	0,334				92-16131
1,515	1,220	0,393	50 004 838	50 004 961	50 009 504	
1,533	1,220	0,334	50 004 757	50 004 908		

# VALVE SEAT INSERTS

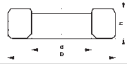

[inch]

D	d	h	HM SEMIFINISHED	HT SEMIFINISHED	HT+ SEMIFINISHED	G1/G2 FINISHED
1,535	1,141	0,393	50 004 840	50 004 963		
1,535	1,259	0,393	50 004 839	50 004 962	50 009 681	
1,547	1,228	0,295				92-22019
1,547	1,259	0,314	50 004 758			
1,555	1,259	0,393	50 004 841	50 004 964		
1,555	1,299	0,334	50 004 759			
1,559	1,318	0,374	50 004 807			
1,562	1,251	0,251	50 004 798			
1,565	1,185	0,374	50 004 760			
1,567	1,251	0,251	50 004 761			
1,568	1,185	0,251	50 004 763			
1,568	1,181	0,303	50 004 765			
1,568	1,228	0,311	50 004 764			
1,568	1,299	0,255	50 004 766			
1,574	1,185	0,291				92-22014
1,574	1,141	0,393	50 004 843	50 004 966	50 009 682	
1,574	1,228	0,251				
1,574	1,259	0,393	50 004 842	50 004 965	50 009 506	
1,574	1,299	0,314				92-25016
1,574	1,318	0,354	50 004 808			
1,576	1,218	0,299				
1,576	1,220	0,287				92-59003
1,576	1,228	0,251				92-59001
1,576	1,220	0,291				92-47023
1,577	1,220	0,314				92-16167
1,577	1,228	0,316				92-16166
1,578	1,318	0,275				92-16120
1,578	1,220	0,295				92-16118
						92-16110
1,580	1,299	0,314			50 009 694	
1,581	1,220	0,383				92-22003
1,582	1,179	0,413		50 004 909		
1,582	1,181	0,413	50 004 767			
1,582	1,338	0,295	50 004 768	50 004 910		
1,585	1,220	0,295				92-16141
						92-16146
1,585	1,220	0,383				92-22004
1,589	1,220	0,334				92-16160
1,592	1,220	0,295				92-16143
1,594	1,259	0,393	50 004 844	50 004 967	50 009 507	
1,597	1,318	0,287				92-16121
1,614	1,181	0,393	50 004 846	50 004 969	50 009 508	
1,614	1,299	0,393	50 004 845	50 004 968	50 009 683	
1,614	1,338	0,295	50 004 769	50 004 911		
1,616	1,200	0,242			92-12005	
1,616	1,220	0,291				92-47024
1,625	1,314	0,251	50 004 799			
1,629	1,251	0,251	50 004 770			
1,629	1,251	0,374	50 004 771			
1,633	1,299	0,393	50 004 847	50 004 970	50 009 684	
1,638	1,338	0,314	50 004 772	50 004 912		
1,653	1,220	0,393	50 004 849	50 004 972	50 009 510	
1,653	1,275	0,314				92-25015
1,653	1,299	0,287				
1,653	1,338	0,393	50 004 848	50 004 971	50 009 511	
1,655	1,299	0,289				92-59000
1,655	1,287	0,340				92-47022
1,659	1,299	0,314			50 009 695	
1,661	1,318	0,413	50 004 773			
1,673	1,338	0,393	50 004 850	50 004 973		
1,679	1,345	0,287				92-22012
1,684	1,326	0,269				92-22007
1,692	1,311	0,314	50 004 775			

# VALVE SEAT INSERTS

[inch]			HM	HT	HT+	G1/G2
D	d	h	SEMIFINISHED	SEMIFINISHED	SEMIFINISHED	FINISHED
1,692	1,259	0,393	50 004 852	50 004 975	50 009 512	
1,692	1,377	0,393	50 004 851	50 004 974	50 009 513	
1,694	1,200	0,242				92-12001
1,694	1,299	0,358	50 004 776			
1,694	1,366	0,244				92-12000
1,694	1,259	0,285				92-47032
1,694	1,299	0,295				92-47029
1,694	1,366	0,244				92-12004
1,696	1,255	0,334				92-47026
1,696	1,295	0,314				92-47020
1,696	1,295	0,315				92-47027
1,696	1,259	0,285				92-47019
1,696	1,295	0,314				92-47033
1,696	1,299	0,295				92-47035
1,696	1,338	0,314				92-16158
1,696	1,354	0,305				92-16170
1,702	1,417	0,314	50 004 777	50 004 913		
1,705	1,385	0,251		50 004 915		
1,705	1,385	0,354	50 004 778	50 004 914		
1,712	1,377	0,393	50 004 853	50 004 976		
1,716	1,377	0,311				92-22006
1,727	1,358	0,291				92-16155
1,727	1,358	0,307				92-16153
1,732	1,299	0,393	50 004 855	50 004 978	50 009 685	
1,732	1,417	0,393	50 004 854			
1,732	1,377	0,334				92-34003
1,733	1,334	0,374	50 004 779			
1,733	1,358	0,257				
1,733	1,405	0,307				
1,735	1,395	0,279				92-22010
1,735	1,340	0,354				92-47003
1,736	1,374	0,320				92-25023
1,736	1,397	0,307				92-34006
1,736	1,413	0,307				92-25021
1,736	1,377	0,318				92-25011
1,737	1,397	0,273		50 009 618		
1,737	1,417	0,354		50 004 999	50 009 514	
1,738	1,358	0,307				92-16116
1,742	1,456	0,314	50 004 780			
1,743	1,340	0,362				92-47004
1,751	1,181	0,393	50 004 858	50 004 981	50 009 515	
1,751	1,417	0,393	50 004 856	50 004 979	50 009 516	
1,751	1,417	0,433	50 004 857	50 004 980	50 009 517	
1,755	1,374	0,251	50 004 781			
1,755	1,374	0,314	50 004 782			
1,771	1,338	0,472	50 004 860	50 004 983	50 009 687	
1,771	1,456	0,472	50 004 859	50 004 982	50 009 686	
1,773	1,338	0,295				92-47028
1,773	1,366	0,318				
1,773	1,417	0,283				92-22022
1,774	1,456	0,326				92-16112
1,775	1,338	0,295				92-47034
1,786	1,405	0,287	50 004 783	50 004 919		
1,791	1,456	0,472	50 004 861	50 004 984		
1,796	1,417	0,389	50 004 784			
1,797	1,417	0,393				92-22001
1,801	1,417	0,393				92-22002
1,805	1,456	0,322				92-16114
1,811	1,338	0,472	50 004 863	50 004 986	50 009 518	
1,811	1,433	0,311				
1,811	1,496	0,472	50 004 862	50 004 985		
1,811	1,417	0,393				92-16133
1,812	1,468	0,307				

# VALVE SEAT INSERTS

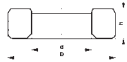

[inch]

D	d	h	HM SEMIFINISHED	HT SEMIFINISHED	HT+ SEMIFINISHED	G1/G2 FINISHED
1,812	1,476	0,318				92-47021
1,813	1,366	0,311				92-34002
1,814	1,358	0,350				92-34005
1,814	1,415	0,269				92-22013
1,814	1,468	0,307				92-25020
1,814	1,476	0,242				92-47001
1,815	1,417	0,393				92-16135
1,816	1,496	0,275		50 004 998		
1,816	1,484	0,251	50 004 785			
1,819	1,417	0,393				92-16137
1,822	1,476	0,250				92-47002
1,830	1,437	0,375	50 004 786			
1,830	1,496	0,472	50 004 864	50 004 987		
1,850	1,417	0,472	50 004 866	50 004 989	50 009 688	
1,850	1,535	0,472	50 004 865	50 004 988		
1,856	1,456	0,338		50 004 930		
1,865	1,574	0,303				92-16157
1,865	1,440	0,307				92-16156
1,870	1,535	0,472	50 004 867	50 004 990		
1,872	1,513	0,261				92-22009
1,879	1,500	0,251	50 004 787			
1,879	1,500	0,374	50 004 788	50 004 924		
1,881	1,625	0,251	50 004 789	50 004 925		
1,881	1,625	0,374	50 004 790	50 004 926		
1,881	1,598	0,251	50 004 791			
1,889	1,456	0,472	50 004 870	50 004 993	50 009 519	
1,889	1,496	0,433	50 004 869	50 004 992		
1,889	1,574	0,472	50 004 868	50 004 991		
1,890	1,456	0,275				92-12003
1,890	1,535	0,275				92-12002
1,891	1,476	0,488				
1,891	1,535	0,244				92-22021
1,892	1,555	0,271				92-34004
1,893	1,498	0,314				92-25009
1,893	1,578	0,314				92-25010
1,932	1,515	0,307				92-47039
1,932	1,555	0,307				92-47037
1,932	1,535	0,295				92-22005
1,932	1,574	0,450				92-47013
1,932	1,574	0,372				92-47015
1,936	1,652	0,452				92-22018
1,940	1,574	0,454				92-47014
1,940	1,574	0,379				92-47016
1,971	1,555	0,297				92-47040
1,972	1,692	0,393		50 009 607		
1,980	1,692	0,401		50 009 608		
1,988	1,692	0,409		50 009 609		
2,005	1,625	0,251	50 004 792			
2,005	1,625	0,314	50 004 793			
2,010	1,456	0,295				92-16106
2,011	1,637	0,293				92-25022
2,011	1,641	0,295				92-25012
2,012	1,577	0,375				92-47006
2,018	1,456	0,295				92-16140
2,018	1,458	0,297				92-16145
2,025	1,456	0,295				92-16142
2,047	1,535	0,405				92-34001
2,050	1,649	0,305				92-47038
2,050	1,653	0,299				92-47036
2,090	1,696	0,381	50 004 871			
2,090	1,692	0,293				92-25004
2,090	1,692	0,330				92-16162
2,090	1,692	0,360				92-16126



# VALVE SEAT INSERTS

[inch]			HM	HT	HT+	G1/G2
D	d	h	SEMIFINISHED	SEMIFINISHED	SEMIFINISHED	FINISHED
2,090	1,692	0,362				92-16127
2,090	1,692	0,374				
2,090	1,692	0,381				92-16104
2,090	1,692	0,389				92-25003
2,094	1,692	0,275			50 009 690	
2,098	1,692	0,370				92-16149
2,098	1,692	0,389				92-16148
2,098	1,692	0,397				92-25014
2,106	1,661	0,381				
2,106	1,692	0,401				92-16105
2,106	1,700	0,377				92-16128
2,109	1,696	0,401	50 004 794			
2,114	1,692	0,393			50 009 691	
2,128	1,746	0,262				92-47011
2,129	1,748	0,263				92-47005
2,133	1,692	0,338		50 004 931	50 009 689	
2,133	1,692	0,393		50 004 916	50 009 520	
2,136	1,746	0,270				92-47012
2,151	1,720	0,393			50 009 692	
2,165	1,732	0,472	50 004 800			
2,169	1,692	0,393			50 009 522	
2,204	1,870	0,295				92-34000
2,205	1,771	0,413				92-16132
2,209	1,771	0,413				92-16134
2,211	1,852	0,452				92-22017
2,212	1,771	0,413				92-16136
2,228	1,769	0,372				92-47009
2,295	1,929	0,267				92-47008
2,327	1,929	0,267				92-47007
2,365	1,929	0,314				
2,366	2,007	0,326				92-16161
2,366	1,940	0,330				92-16150
2,366	2,007	0,350		50 009 604		92-16100
2,366	2,015	0,330				92-16122
						92-16151
2,374	2,007	0,358		50 009 605		92-16147
2,374	2,015	0,338				92-16152
2,382	2,007	0,366		50 009 606		92-16101
2,382	2,015	0,350				92-16123
2,405	1,889	0,350				92-25001
2,405	1,929	0,267				92-25005
2,405	1,929	0,346				92-25002
2,405	1,929	0,350				92-25008
2,405	2,007	0,354				92-16163
2,405	2,007	0,409				92-25000
2,421	1,929	0,354				

<b>D</b>	<b>PROGRAMMERGÄNZUNGEN</b>
----------	----------------------------

---

<b>E</b>	<b>ADDITIONS TO THE RANGE</b>
----------	-------------------------------

---

<b>F</b>	<b>COMPLÉMENTS DE LA GAMME</b>
----------	--------------------------------

---

<b>ES</b>	<b>ADICIONES AL PROGRAMA</b>
-----------	------------------------------

---

<b>RU</b>	<b>ДОПОЛНЕНИЯ К ПРОГРАММЕ</b>
-----------	-------------------------------

---

PG	KS-No.			PG	KS-No.		
<b>BMW</b>				<b>FIAT</b>			
					<b>81-11120</b>	78	N47 D16 A
	<b>111226</b>	77	N13 B16 A			84	B37 C15 A, B37 D15 A, B47 C20 A, B47 D20 A, B57 D30 A, B57 D30 B, B57 D30 C, N47 D20 A, N47 D20 B, N47 D20 C, N47 D20 D, N57 D30 A, N57 D30 B, N57 D30 C, B37 C15, N47 D20T0, N47 D20UL, N47S D20A, N57 D30 OL
	<b>111227</b>	78	N47 D16 A				
	<b>111228</b>	78	N47 D16 A				
	<b>111229</b>	89	N63 B44 A, N63 B44 B, N63 B44 C		<b>171124</b>	79,5	198 A3.000, 198 A6.000
	<b>111230</b>	89	N63 B44 A, N63 B44 B, N63 B44 C		<b>171125</b>	72	198 A1.000, 198 A4.000
	<b>111231</b>	79	K1200 (4ZYL. REIHE)		<b>171126</b>	72	198 A1.000, 198 A4.000
		101	Boxermotor B2		<b>181117</b>	85	RHH
	<b>111232</b>	79	K1200 (4ZYL. REIHE)		<b>539044</b>	80	R9M 408, R9M 413, R9M 450, R9M 452
		101	Boxermotor B2		<b>539045</b>	80	R9M 408, R9M 413, R9M 450, R9M 452
	<b>111233</b>	82	B38 A15 A, B38 B15 A, B46 A20 B, B48 A20 A, B48 A20 B, B48 B20 A, B48 B20 B, B58 B30 A, B38 B15, B48 B20		<b>539046</b>	75	9HM (DV6UC)
	<b>111234</b>	82	B38 A15 A, B38 B15 A, B46 A20 B, B48 A20 A, B48 A20 B, B48 B20 A, B48 B20 B, B58 B30 A, B38 B15, B48 B20		<b>539047</b>	75	9HM (DV6UC)
	<b>111800</b>	85	N53 B30, N53 B30 A		<b>539050</b>	85	4HP, 4HR, 4HT (DW12BTED4), 4HW (DW12ATED4), 4HX (DW12TED4)
	<b>111801</b>	85	N53 B30, N53 B30 A		<b>539051</b>	85	4HP, 4HR, 4HT (DW12BTED4), 4HW (DW12ATED4), 4HX (DW12TED4)
	<b>81-11118</b>	82	N43 B16 A, N43 B16 AA		<b>81-17132</b>	135	F3 BEE 681 C, F3 BEE 681 D, F3 BEE 681 E, F3 BEE 681 G, F3 BEE 681 V
		84	N40 B16 A, N42 B18 A, N42 B20 A, N42 B20 B, N45 B16 A, N45 B16 TU2, N46 B18 A, N46 B20 A, N46 B20 B, N46 B20 BD, N46 B20 C, N46 B20 CC, N46 B20 CD, N46 B20 E, N42 B20 BZ, N45 B16 TU2 OL, N46 B20 LC, N46 B20 TU2, N46 B20 TU2 UL		<b>81-17133</b>	135	F3 BEE 681 C, F3 BEE 681 D, F3 BEE 681 E, F3 BEE 681 G, F3 BEE 681 V
		89	S63 B44 A		<b>81-17134</b>	125	F3AE0681B, F3AE0681E
		92	N62 B44 A		<b>81-17135</b>	125	F3AE0681B, F3AE0681E
		93	N62 B48 A, N62 B48 B, N62 B48		<b>81-18111</b>	75	9HM (DV6UC), 9HU
	<b>81-11119</b>	78	N47 D16 A				
		84	B37 C15 A, B37 D15 A, B47 C20 A, B47 D20 A, B57 D30 A, B57 D30 B, B57 D30 C, N47 D20 A, N47 D20 B, N47 D20 C, N47 D20 D, N57 D30 A, N57 D30 B, N57 D30 C, B37 C15, N47 D20T0, N47 D20UL, N47S D20A, N57 D30 OL				

NEW

PG	KS-No.			PG	KS-No.		
	81-4220	72 79,5 82 83	198 A1.000, 198 A4.000 198 A2.000, 198 A3.000, 198 A6.000, 350 A2.000, 955 A3.000, 955 A4.000 192 A5.000, 192 B1.000, 937 A4.000, 937 A5.000, 939 A1.000, 939 A2.000, 939 A3.000 198 A5.000, 263 A1.000, 844 A2.000, 939 B5.000, 940 A5.000		181118	71,9	M1CA, M1CB, M1DA, M1DC, M1DD, M1DH, M1JA, M1JC, M1JE, M1JH, M1JJ, M1JL, M1JM, M1JU, M2DA, M2DB, M2DC, M2GA, M2GB, P4JA, P4JB, P4JC, P4JD, SFCA, SFCB, SFCC, SFCD, SFDA, SFDB, SFDC, SFJA, SFJB, SFJC, SFJD, SFJE, SFJF, SFJH, SFJJ, SFJK, SFJL, SFJN, SFJP, XMJA, XMJB, YYJA, YYJB, YYJC, YYJD, YYJE
	81-4221	69,6	169 A1.000, 169 A5.000, 188 A8.000, 188 A9.000, 199 A2.000, 199 A3.000, 199 A9.000, 199 B1.000, 199 B2.000, 199 B4.000, 199 B8.000, 223 A9.000		181120	71,9	M1CA, M1CB, M1DA, M1DC, M1DD, M1DH, M1JA, M1JC, M1JE, M1JH, M1JJ, M1JL, M1JM, M1JU, M2DA, M2DB, M2DC, M2GA, M2GB, P4JA, P4JB, P4JC, P4JD, SFCA, SFCB, SFCC, SFCD, SFDA, SFDB, SFDC, SFJA, SFJB, SFJC, SFJD, SFJE, SFJF, SFJH, SFJJ, SFJK, SFJL, SFJN, SFJP, XMJA, XMJB, YYJA, YYJB, YYJC, YYJD, YYJE
	50 007 010	85	DW10BTED4, RHK, RHM (DW10ATED4), RHR, RHW (DW10ATED4)		471206	81,6 82,4	LCBB, LCBC, LCBD, LCBE LCBA
	50 007 024	69,6	169 A1.000, 188 A9.000, 199 A2.000, 199 A3.000, 223 A9.000		471207	83	HUBA, HUWA, HYDA, HYDB, HYDC
	50 007 038	82	182 B9.000, 186 A6.000, 186 A9.000, 188 A2.000, 188 B2.000, 192 A1.000, 192 A3.000, 192 A8.000, 192 A9.000, 199 A5.000, 223 A7.000, 223 B1.000, 223 B2.000, 937 A7.000, 939 A1.000		471209	81,6 82,4	LCBB, LCBC, LCBD, LCBE LCBA
	50 007 047	95,8	F1CE0441A, F1CE3481E, F1CE3481M, F1CE3481N		539046	83	HUBA, HUWA, HYDA, HYDB, HYDC
	50 007 048	95,8	F1CE0441A, F1CE0481D, F1CE3481E, F1CE3481M, F1CE3481N			73,5	15DSOX, AEDA, UGCA, UGCB, UGCC, UGJC, UGJE, UGJG, UGJM, XUCA, XUCC, XUCD, XUJA, XUJB, XUJC, XUJD, XUJE, XUJF, XUJG, XUJH, XUJK, XUJL, XUJM, XUJN, XVCA, XVCB, XVCC, XVGA, XVGB, XVGC, XVJA, XVJB, XVJC, XVJD, XVJE, XWCA, XWCB, XWDA, XWDB, XWDC, XWDD, XWDE, XWGA, XWGB, XWGC, XWJA, XWJB, XWJC, XWMB, XWMC, XXCA, XXCB, XXCC, XXDA, XXDB, XXDC, XXGA
	50 007 054	93	8140.47, 8140.47R, 8140.67, 8140.47			75	NGCA, NGDA, T1BA, T1BB, T1BC, T1DA, T1DB, T1WA, T1WB, T3CA, T3CB, T3CC, T3DA, T3DB, T3JA, T3JB, TZJA, TZJB, U3CA, Z2JA, ZTJA, ZTJB, ZTJC
	50 007 088	85	4HW (DW12ATED4)				
	50 007 104	82	192 A5.000, 192 B1.000, 937 A4.000, 937 A5.000, 939 A2.000				
	50 007 105	82	192 A5.000, 192 B1.000, 937 A4.000, 937 A5.000, 939 A2.000				
<b>FORD</b>							
	181117	85	TXBA, TXBB, TXDA, TXDB, TXMA, TXWA, TYDA, UFDA, UFDB, UKDA, UKDB				

**NEW**



PG	KS-No.			PG	KS-No.					
	539047	73,5	15DSOX, AEDA, UGCA, UGCB, UGCC, UGJC, UGJE, UGJG, UGJM, XUCA, XUCC, XUUCD, XUJA, XUJB, XUJC, XUJD, XUJE, XUJF, XUJG, XUJH, XUJK, XUJL, XUJM, XUJN, XVCA, XVCB, XVCC, XVGA, XVGB, XVGC, XVJA, XVJB, XVJC, XVJD, XVJE, XWCA, XWCB, XWDA, XWDB, XWDC, XWDD, XWDE, XWGA, XWGB, XWGC, XWJA, XWJB, XWJC, XWMB, XWMC, XXCA, XXCB, XXCC, XXDA, XXDB, XXDC, XXGA		81-18112	85	KNWA, Q4BA, Q4WA			
			75				NGCA, NGDA, T1BA, T1BB, T1BC, T1DA, T1DB, T1WA, T1WB, T3CA, T3CB, T3CC, T3DA, T3DB, T3JA, T3JB, TZJA, TZJB, U3CA, Z2JA, ZTJA, ZTJB, ZTJC	86	ABFA, CV24, CVF5, CVFF, CVR5, CVRA, CVRB, CVRC, CY14, CY24, CYF4, CYF5, CYFA, CYFB, CYFC, CYFD, CYFF, CYFG, CYRA, CYRB, CYRC, D3FA, D5BA, D6BA, DRF4, DRF5, DRFA, DRFB, DRFC, DRFD, DRFE, DRFF, DRFG, DRR5, DRRA, DRRB, DRRC, F3FA, FIFA, FMBA, HJBA, HJBB, HJBC, N7BA, N7BB, P8FA, P8FB, PGFA, PGFB, QJBA, QJBB, QJBC, QJBD, QVFA, QWFA, SDBA, SRFA, SRFB, SRFC, SRFD, SRFE, UHFA, UHFB, UHFC, UHR5, USF6, USR6, USRA, USBR, UYR6	
			85				Q4BA, AHW, AHX	89,9	H9FA, H9FB, H9FD, SAFA, SAFB	
			85				Q4BA, AHW, AHX	71,9	M1CA, M1CB, M1DA, M1DC, M1DD, M1DH, M1JA, M1JC, M1JE, M1JH, M1JJ, M1JL, M1JM, M1JU, M2DA, M2DB, M2DC, M2GA, M2GB, P4JA, P4JB, P4JC, P4JD, SFCA, SFCB, SFCC, SFCD, SFDA, SFDB, SFDC, SFJA, SFJB, SFJC, SFJD, SFJE, SFJF, SFJH, SFJJ, SFJK, SFJL, SFJN, SFJP, XMJA, XMJB, YYJA, YYJB, YYJC, YYJD, YYJE	
			125				F3AE3681D	75	T3JA	
81-17134	125	F3AE3681D	79	IQDB, IQJA, JQDA, JQDB, JQMA, JQMB, JTBA, JTBB, JTDA, JTDB, JTJA, JTJB, JTMA, JTWA, JTWB, M8DA, M8DB, M8MA, M9DA, M9DB, UNCA, UNCB, UNCE, UNCF						
81-17135	125	F3AE3681D	81-33115	93	BRT					
	81-18111	73,5	15DSOX, AEDA, UGCA, UGCB, UGCC, UGJC, UGJE, UGJG, UGJM, XUCA, XUCC, XUUCD, XUJA, XUJB, XUJC, XUJD, XUJE, XUJF, XUJG, XUJH, XUJK, XUJL, XUJM, XUJN, XVCA, XVCB, XVCC, XVGA, XVGB, XVGC, XVJA, XVJB, XVJC, XVJD, XVJE, XWCA, XWCB, XWDA, XWDB, XWDC, XWDD, XWDE, XWGA, XWGB, XWGC, XWJA, XWJB, XWJC, XWMB, XWMC, XXCA, XXCB, XXCC, XXDA, XXDB, XXDC, XXGA		81-33118	84	ARC			
			73,7				F6JA, F6JB, F6JC, F6JD, KVJA	81-33121	84	ARC
			75				G8DA, G8DB, G8DC, G8DD, G8DE, G8DF, GPDA, GPDC, HHDA, HHDB, HHJA, HHJB, HHJC, HHJD, HHJE, HHJF, MTDA, NGCA, NGDA, T1BA, T1BB, T1BC, T1DA, T1DB, T1WA, T1WB, T3CA, T3CB, T3CC, T3DA, T3DB, T3JA, T3JB, TZJA, TZJB, U3CA, UBJA, Z2JA, ZTJA, ZTJB, ZTJC	81-33122	84	ARC
			73,7				F6JD, KVJA	81-4221	69,6	FD4
			77,25				F6A	81-4222	77,25	F6A
	81-18111	73,5	15DSOX, AEDA, UGCA, UGCB, UGCC, UGJC, UGJE, UGJG, UGJM, XUCA, XUCC, XUUCD, XUJA, XUJB, XUJC, XUJD, XUJE, XUJF, XUJG, XUJH, XUJK, XUJL, XUJM, XUJN, XVCA, XVCB, XVCC, XVGA, XVGB, XVGC, XVJA, XVJB, XVJC, XVJD, XVJE, XWCA, XWCB, XWDA, XWDB, XWDC, XWDD, XWDE, XWGA, XWGB, XWGC, XWJA, XWJB, XWJC, XWMB, XWMC, XXCA, XXCB, XXCC, XXDA, XXDB, XXDC, XXGA		92-22017	125	F 6 L 413 F, F 6 L 413 FZ			
							92-22018	125	F 6 L 413 F, F 6 L 413 FZ	

NEW

PG	KS-No.			PG	KS-No.		
	20101419000	125	F3AE3681D		50 007 101	89,9	D2FA, D2FB, D4FA, DOFA, F4FA, FXFA, H9FA
	50 007 024	69,6	BAAA		50 007 102	89,9	D2FA, D2FB, D4FA, DOFA, F4FA, FXFA, H9FA
	50 007 028	89,9	H9FD, JXFA, JXFC, PHFA, PHFC	<b>LANCIA</b>			
	50 007 029	82,5	BHDA, BHDB, BHPA, C9DA, C9DB, C9DC, F9DA, F9DB, FFBA, FFDA, FFWA, HCPA, HCPB, KHBA, KKDA, KKDB, P7PA, QYBA, QYWA, R2PA, RTN, RTP, RTQ, RWPA		171124	79,5	944 A 3.000
	50 007 050	86	CVF5, CVFF, CYF5, CYFA, CYFB, CYFC, CYFF, CYFG, DRF5, DRFA, DRFB, DRFC, DRFF, DRFG, P8FA, P8FB, PGFA, PGFB, QVFA, QWFA, SRFA, SRFB, SRFC, SRFD, SRFE		171125	72	198 A1.000, 198 A4.000
	50 007 051	86	CVF5, CVFF, CYF5, CYFA, CYFB, CYFC, CYFF, CYFG, DRF5, DRFA, DRFB, DRFC, DRFF, DRFG, P8FA, P8FB, PGFA, PGFB, QVFA, QWFA, SRFA, SRFB, SRFC, SRFD, SRFE		171126	72	198 A1.000, 198 A4.000
	50 007 081	73,7	F6JA, F6JB, F6JC		539050	85	4HP, 4HR, 4HT, 4HW (DW12ATED4)
	50 007 083	73,7	F6JA, F6JB, F6JC		539051	85	4HP, 4HR, 4HT, 4HW (DW12ATED4)
	50 007 085	85	Q4BA, Q4WA		81-4220	72	198 A1.000, 198 A4.000
	50 007 093	75	G8DA, G8DB, G8DC, GPDA, GPDC, HHDA, HHDB, HHJA, HHJB, HHJC, HHJD, HHJE, HHJF, MTDA, UBJA			79,5	198 A2.000, 350 A2.000, 944 A 3.000, 955 A4.000
	50 007 094	75	G8DA, G8DB, G8DC, GPDA, GPDC, HHDA, HHDB, HHJA, HHJB, HHJC, HHJD, HHJE, HHJF, MTDA, UBJA			82	841 G.000, 841 N.000, 844 A1.000
	50 007 095	85	Q4BA, Q4WA		81-4221	83	198 A5.000, 844 A2.000
	50 007 096	85	AZBA, AZBC, AZWA, AZWC, G6DA, G6DB, G6DC, G6DD, G6DE, G6DF, G6DG, KLBA, KLWA, LPBA, QXBA, QXBB, QXWA, QXWB		50 007 010	85	RHK (DW10UTED4), RHR (DW10BTED4), RHW (DW10ATED4)
	50 007 099	85	AZBA, AZBC, AZWA, AZWC, G6DA, G6DB, G6DC, G6DD, G6DE, G6DF, G6DG, KLBA, KLWA, LPBA, QXBA, QXBB, QXWA, QXWB		50 007 024	69,6	188 A9.000, 199 A2.000, 199 A3.000
					50 007 038	82	188 B2.000
					50 007 088	85	4HW (DW12ATED4)
				<b>MERCEDES-BENZ</b>			
					16211	132	OM 471
					16212	132	OM 471
					162160	125	OM 470
					162170	125	OM 470
					162180	139	OM 472, OM 473
					162190	139	OM 472, OM 473

**NEW**

PG	KS-No.			PG	KS-No.			
	261142	82	M 271		92-16167	102	OM 900, OM 902, OM 904, OM 906, OM 907, OM 909	
	261143	82	M 271			106	M 906, OM 924, OM 925, OM 926, OM 923	
	261148	80,4	M 264		92-16170	128	OM 457, OM 458, OM 460	
		83	M 260, M 264, M 270, M 274			130	OM 521, OM 522, OM 541, OM 542, OM 941, OM 942	
	261149	83	M 270, M 274		20100390601	102	OM 902, OM 906, OM 909	
	261150	92,9	M 276, M 278			106	M 906, OM 926	
	261151	92,9	M 276, M 278		50 007 076	76	OM 607, OM 608	
	261152	82	OM 654, OM 656		20100344001	110		
	261153	82	OM 654, OM 656			125	OM 401, OM 402, OM 403, OM 407	
	261154	80,4	M 264			128	M 476, OM 421, OM 422, OM 423, OM 424, OM 427, OM 440, OM 441, OM 442, OM 443, OM 444, OM 445, OM 446, OM 447, OM 481	
		83	M 260, M 264			130	OM 440, OM 441, OM 442, OM 443	
	261155	82	M 271		20100350062	128	OM 457, OM 458, OM 460	
	269000	78	OM 654			130	OM 521, OM 522, OM 541, OM 542, OM 941, OM 942	
	269001	78	OM 654	<b>NISSAN</b>				
	539044	80	OM 622, OM 626		539044	80	R9M, R9M 413, R9M 452	
	539045	80	OM 622, OM 626		539045	80	R9M, R9M 413, R9M 452	
	81-16110	125	OM 470		539048	72,2	H4B 408	
		132	OM 471		539052	72,2	H4B 408	
		139	OM 472, OM 473		81-51000	76	K9K 270, K9K 276, K9K 278, K9K 282, K9K 292, K9K 400, K9K 410, K9K 430, K9K 608, K9K 628, K9K 636, K9K 646, K9K 700, K9K 704, K9K 708, K9K 710, K9K 714, K9K 716, K9K 718, K9K 722, K9K 732, K9K 764, K9K 772, K9K 872, K9K 892, K9K 896, K9K 270, K9K 274	
	81-26186	83	OM 640, OM 642		81-51001	76	K9K 270, K9K 276, K9K 278, K9K 282, K9K 292, K9K 400, K9K 410, K9K 430, K9K 608, K9K 628, K9K 636, K9K 646, K9K 700, K9K 704, K9K 708, K9K 710, K9K 714, K9K 716, K9K 718, K9K 722, K9K 732, K9K 764, K9K 772, K9K 872, K9K 892, K9K 896, K9K 270, K9K 274	
	81-26187	83	OM 651					
	81-51000	76	OM 607					
	81-51001	76	OM 607					
	92-16165	102	OM 900, OM 902, OM 904, OM 906, OM 907, OM 909					
		106	OM 924, OM 925, OM 926, OM 923					
	92-16166	102	OM 900, OM 902, OM 904, OM 906					
		106	OM 924, OM 926					

NEW

PG	KS-No.			PG	KS-No.											
	<b>81-51002</b>	84	M1D, M9R, M9R 630, M9R 760, M9R 780, M9R 782		<b>81-51000</b>	76	K9K 500, K9K 608, K9K 609, K9K 612, K9K 628, K9K 629, K9K 636, K9K 646, K9K 647, K9K 656, K9K 657, K9K 700, K9K 702, K9K 704, K9K 706, K9K 710, K9K 712, K9K 714, K9K 716, K9K 718, K9K 722, K9K 724, K9K 728, K9K 729, K9K 732, K9K 734, K9K 740, K9K 750, K9K 752, K9K 760, K9K 762, K9K 764, K9K 766, K9K 768, K9K 770, K9K 772, K9K 774, K9K 780, K9K 782, K9K 790, K9K 792, K9K 794, K9K 796, K9K 800, K9K 802, K9K 804, K9K 806, K9K 808, K9K 812, K9K 816, K9K 820, K9K 826, K9K 830, K9K 832, K9K 834, K9K 836, K9K 837, K9K 838, K9K 840, K9K 846, K9K 856, K9K 858, K9K 872, K9K 873, K9K 884, K9K 896, K9K 898, K9K P 732, K9K 260, K9K 262, K9K 272, K9K 838									
		85	M9T, M9T 670, M9T 672, M9T 676, M9T 678, M9T 680, M9T 686, M9T 690, M9T 692, M9T 694, M9T 696, M9T 698, M9T 702, M9T 706, M9T 870, M9T 880, M9T 896													
	<b>81-51003</b>	84	M1D, M9R, M9R 760, M9R 780, M9R 782					<b>81-51001</b>	76	K9K 500, K9K 608, K9K 609, K9K 612, K9K 628, K9K 629, K9K 636, K9K 646, K9K 647, K9K 656, K9K 657, K9K 700, K9K 702, K9K 704, K9K 706, K9K 710, K9K 712, K9K 714, K9K 716, K9K 718, K9K 722, K9K 724, K9K 728, K9K 729, K9K 732, K9K 734, K9K 740, K9K 750, K9K 752, K9K 760, K9K 762, K9K 764, K9K 766, K9K 768, K9K 770, K9K 772, K9K 774, K9K 780, K9K 782, K9K 790, K9K 792, K9K 794, K9K 796, K9K 800, K9K 802, K9K 804, K9K 806, K9K 808, K9K 812, K9K 816, K9K 820, K9K 826, K9K 830, K9K 832, K9K 834, K9K 836, K9K 837, K9K 838, K9K 840, K9K 846, K9K 856, K9K 858, K9K 872, K9K 873, K9K 884, K9K 896, K9K 898, K9K P 732, K9K 260, K9K 262, K9K 272, K9K 838						
	<b>81-70006</b>	78	HR12DE, HR16DE													
	<b>81-70007</b>	78	HR12DE, HR16DE													
	<b>81-70008</b>	86	YD22DDT, YD22DDTi, YD22ETI									80	R9M 402, R9M 404			
		89	YD25DDTi, YD25ETI													
	<b>81-70009</b>	86	YD22DDT, YD22DDTi, YD22ETI												76	K9K 500, K9K 608, K9K 609, K9K 612, K9K 628, K9K 629, K9K 636, K9K 646, K9K 647, K9K 656, K9K 657, K9K 700, K9K 702, K9K 704, K9K 706, K9K 710, K9K 712, K9K 714, K9K 716, K9K 718, K9K 722, K9K 724, K9K 728, K9K 729, K9K 732, K9K 734, K9K 740, K9K 750, K9K 752, K9K 760, K9K 762, K9K 764, K9K 766, K9K 768, K9K 770, K9K 772, K9K 774, K9K 780, K9K 782, K9K 790, K9K 792, K9K 794, K9K 796, K9K 800, K9K 802, K9K 804, K9K 806, K9K 808, K9K 812, K9K 816, K9K 820, K9K 826, K9K 830, K9K 832, K9K 834, K9K 836, K9K 837, K9K 838, K9K 840, K9K 846, K9K 856, K9K 858, K9K 872, K9K 873, K9K 884, K9K 896, K9K 898, K9K P 732, K9K 260, K9K 262, K9K 272, K9K 838
		89	YD25DDTi, YD25ETI													
	<b>50 007 017</b>	76	K9K 700, K9K 704, K9K 710, K9K 714, K9K 722													
	<b>50 007 076</b>	76	K9K 700, K9K 702, K9K 704, K9K 710, K9K 714, K9K 718, K9K 722, K9K 728, K9K 892, K9K 896													
	<b>50 007 118</b>	87	G9T 722													
89		G9U 650, G9U 720, G9U 730														
<b>50 007 123</b>	87	G9T 722														
	89	G9U 650, G9U 720, G9U 730														
<b>50 007 124</b>	87	G9T 722														
	89	G9U 650, G9U 720, G9U 730														
<b>50 007 126</b>	87	G9T 722														
	89	G9U 650, G9U 720, G9U 730														
<b>RENAULT</b>																
	<b>539044</b>	80	R9M 402, R9M 404, R9M 408, R9M 409, R9M 413, R9M 414, R9M 450, R9M 452, R9M 453		80	R9M 402, R9M 404										
	<b>539045</b>	80	R9M 402, R9M 404, R9M 408, R9M 409, R9M 413, R9M 414, R9M 450, R9M 452, R9M 453													
	<b>539048</b>	72,2	H4B 400, H4B 401, H4B 408, H5F 400, H5F 403, H5F 404, H5F 408, H5F 412													
	<b>539052</b>	72,2	H4B 400, H4B 401, H4B 408, H5F 400, H5F 403, H5F 404, H5F 408, H5F 412													

**NEW**



NEW

PG	KS-No.			PG	KS-No.																																				
	81-51002	84	M9R 610, M9R 615, M9R 630, M9R 692, M9R 700, M9R 721, M9R 722, M9R 724, M9R 740, M9R 742, M9R 744, M9R 746, M9R 748, M9R 750, M9R 760, M9R 761, M9R 762, M9R 763, M9R 780, M9R 782, M9R 786, M9R 800, M9R 802, M9R 804, M9R 805, M9R 806, M9R 809, M9R 812, M9R 814, M9R 815, M9R 816, M9R 817, M9R 820, M9R 824, M9R 828, M9R 830, M9R 832, M9R 833, M9R 834, M9R 835, M9R 836, M9R 838, M9R 844, M9R 845, M9R 846, M9R 849, M9R 850, M9R 854, M9R 855, M9R 856, M9R 857, M9R 858, M9R 859, M9R 862, M9R 864, M9R 865, M9R 866, M9R A 700, M9R B 610, M9R B 721, M9R C 613, M9R C 615, M9R C 830, M9R G 832, M9Ra 742, M9Rk 800, M9Rk 802, M9Rk 805, M9Rk 816, M9R 891		92-47028	131	DXi 13 440, DXi 13 460, DXi 13 480, DXi 13 500, DXi 13 520																																		
					92-47029			131	DXi 13 440, DXi 13 460, DXi 13 480, DXi 13 500, DXi 13 520																																
					92-47030					123	DXi 11 330, DXi 11 370, DXi 11 440, DXi 11 450																														
					92-47031							123	DXi 11 330, DXi 11 370, DXi 11 440, DXi 11 450																												
					50 007 017									76	K9K 700, K9K 702, K9K 704, K9K 710, K9K 712, K9K 714, K9K 718, K9K 722, K9K 728, K9K 729, K9K 750, K9K 752, K9K 766, K9K 790																										
					50 007 054											93	8140.67.2500, 8140.67.2510, 8140.67.2550, 8140.67.2580, 8140.47.2530																								
					50 007 076													76	K9K 790, K9K 792, K9K 794, K9K 796, K9K 896																						
					50 007 118															87	G9T 600, G9T 605, G9T 606, G9T 607, G9T 642, G9T 645, G9T 700, G9T 702, G9T 703, G9T 706, G9T 707, G9T 710, G9T 712, G9T 720, G9T 722, G9T 742, G9T 743, G9T 750																				
					81-51003																	84	M9R 610, M9R 615, M9R 630, M9R 692, M9R 700, M9R 721, M9R 722, M9R 724, M9R 740, M9R 742, M9R 744, M9R 746, M9R 748, M9R 750, M9R 760, M9R 761, M9R 762, M9R 763, M9R 780, M9R 782, M9R 786, M9R 800, M9R 802, M9R 804, M9R 805, M9R 809, M9R 814, M9R 815, M9R 816, M9R 817, M9R 820, M9R 824, M9R 830, M9R 832, M9R 833, M9R 844, M9R 845, M9R 849, M9R 855, M9R 856, M9R 862, M9R 864, M9R 865, M9R 866, M9R A 700, M9R B 610, M9R B 721, M9R C 613, M9R C 615, M9R C 830, M9R G 832, M9Ra 742, M9Rk 800, M9Rk 802, M9Rk 805, M9Rk 816		50 007 123	87	G9T 600, G9T 605, G9T 606, G9T 607, G9T 642, G9T 645, G9T 700, G9T 702, G9T 703, G9T 706, G9T 707, G9T 710, G9T 712, G9T 720, G9T 722, G9T 742, G9T 743, G9T 750														
																									81-59006			85	M9T 706, M9T 896, M9T 898		50 007 124	87	G9T 600, G9T 605, G9T 606, G9T 607, G9T 642, G9T 645, G9T 700, G9T 702, G9T 703, G9T 706, G9T 707, G9T 710, G9T 712, G9T 720, G9T 722, G9T 742, G9T 743, G9T 750								
81-59007	102	MIDR 06.02.26 I, MIDR 06.02.26 K, MIDR 06.02.26 L, MIDR 06.02.26 L2, MIDR 06.02.26 M, MIDR 06.02.26 M2		50 007 126		87	G9T 600, G9T 605, G9T 606, G9T 607, G9T 642, G9T 645, G9T 700, G9T 702, G9T 703, G9T 706, G9T 707, G9T 710, G9T 712, G9T 720, G9T 722, G9T 742, G9T 743, G9T 750																																		
				92-22021				105	TD 226 B-6																									SKODA	331156	71	CJZA, CJZB, CJZC, CJZD, CYVA, CYVB				
										92-22022	105																											TD 226 B-6		SKODA	331156

PG	KS-No.			PG	KS-No.		
	331157	71	CJZA, CJZB, CJZC, CJZD, CYVA, CYVB		81-33121	71	CBZA, CBZB, CJZA, CJZB, CJZD
	331158	74,5	CHPA, CHPB, CHZB, CHZC, CHZD, CHZJ, CZCA, CZDA, DBYA, DKLA, DKRF			76,5	AUA, AUB, AWY, AXP, AZQ, BBM, BBY, BBZ, BCA, BKY, BLF, BMD, BME, BTS, BUD, BXW, BZG, CAVE, CAXA, CAXC, CEVA, CFNA, CGGA, CGGB, CGPA, CGPB, CGPC, CHFA, CHTA, CLSA, CTHE
	331159	74,5	CHPA, CHPB, CHZB, CHZC, CZCA, CZDA			81	AGN, AGU, ARX, ARZ, AUM, AUQ, AVU, AWT, BGU
	331160	82,5	CHHA, CHHB, CJXA, DKTB, DLBA, DNUA			82,5	AMX, BBG, BLR, BLX, BLY, BVX, BVY, BVZ, BWA, BZB, CCZA, CDAA, CDAB, CHHB, CJSA, CJSB, CJSC
	331161	71	CBZA, CBZB		81-33122	71	CBZA, CBZB, CJZB
	331162	82,5	CHHA, CHHB, CJSA, CJSB, CJSC, CJXA, DKTB, DLBA, DNUA			76,5	AUA, AUB, AWY, AXP, AZQ, BBM, BBY, BBZ, BCA, BKY, BLF, BMD, BME, BTS, BUD, BXW, BZG, CAVE, CAXA, CAXC, CEVA, CFNA, CGGA, CGGB, CGPA, CGPB, CGPC, CHFA, CHTA, CLSA, CTHE
	331163	74,5	CPWA			81	AGN, AGU, ARX, ARZ, AUM, AUQ, AVU, AWT, BGU
	331164	74,5	CHZD, CHZJ, CPWA, DBYA, DKLA, DKRF			82,5	AMX, BBG, BLR, BLX, BLY, BVX, BVY, BVZ, BWA, BZB, CCZA, CDAA, CDAB, CHHB, CJSA, CJSB, CJSC
	398000	74,5	CHYA, CHYB, CZEA, DAFA		81-33123	71	CJZA, CJZB, CYVB
		74,51	CPGA			74,5	CHYA, CHYB, CHZD, CZEA, DAFA
		76,5	CWVA, CWVB			74,51	CPGA
	398001	74,5	CHYA, CHYB, CZEA, DAFA			76,5	CWVA, CWVB
		74,51	CPGA		81-33124	71	CJZA, CJZB, CYVB
		76,5	CWVA, CWVB			74,5	CHYA, CHYB, CHZD, CZEA, DAFA
	81-33115	79,5	ATD, AVB, AXR, BKC, BLS, BXE			74,51	CPGA
		81	BMM			76,5	CWVA, CWVB
	81-33116	79,5	CAYA, CAYB, CAYC, CFWA, CLHA, CLHB, CLNA, CRKB, CUSA, CUSB, CUTA, CXXA, CXXB, DBKA			71	CJZA, CJZB, CYVB
	81-33117	79,5	CAYA, CAYB, CAYC, CFWA, CLHA, CLHB, CLNA, CRKB, CUSA, CUSB, CUTA, CXXA, CXXB, DBKA			74,5	CHYA, CHYB, CHZD, CZEA, DAFA
	81-33118	71	CBZA, CBZB, CJZA, CJZB, CJZD		81-33125	81	BSE, BSF, CCSA
		76,5	AUA, AUB, AWY, AXP, AZQ, BBM, BBY, BBZ, BCA, BKY, BLF, BMD, BME, BTS, BUD, BXW, BZG, CAVE, CAXA, CAXC, CEVA, CFNA, CGGA, CGGB, CGPA, CGPB, CGPC, CHFA, CHTA, CLSA, CTHE		81-3323	78,3	BDG
		81	AGN, AGU, ARX, ARZ, AUM, AUQ, AVU, AWT, BGU		81-3324	78,3	BDG
		82,5	AMX, BBG, BLR, BLX, BLY, BVX, BVY, BVZ, BWA, BZB, CCZA, CDAA, CDAB, CHHB, CJSA, CJSB, CJSC		50 006 344	78,3	BDG
	81-33119	89	CDVA		50 006 345	78,3	BDG
	81-33120	89	CDVA		50 006 346	78,3	BDG
					50 006 347	78,3	BDG
					50 007 018	76,5	CAVE, CAXA, CAXC, CTHE

NEW

PG	KS-No.			PG	KS-No.		
	50 007 019	76,5	BTS, CTHE		331161	71	CBZA, CBZB, CBZC
	50 007 020	79,5 81	CAYB, CAYC, CLNA CBBB, CBDB, CEGA, CFFB, CFGB, CFHC, CFHF, CFJA, CLCA, CLCB, CLJA		331162	82,5	CHHA, CHHB, CJSA, CJSB, CJSC, CJXA, CJXB, CJXC, CJXD, CJXE, CJXG, CNSB, CNTA, CNTC, CPKA, CPLA, CPPA, CPRA, CULC, CXBA, CXBB, CXCA, CXCB, CXDA, CYFB, DAJA, DAJB, DEDA, DJHA, DJHB, DJHC, DJJA, DKTB, DLBA, DLRA, DLRB, DMFA, DNJA, DNUA
	50 007 022	79,5 81	CAYB, CAYC, CLNA CBBB, CBDB, CEGA, CFFB, CFGB, CFHC, CFHF, CFJA, CLCA, CLCB, CLJA		331163	84,5 74,5	CGEA, CGFA, CJTA CPVA, CPVB, CPWA, CXSB
	50 007 025	76,5	CFNA, CLSA		331164	74,5	CHZD, CHZJ, CPVA, CPVB, CPWA, CXSB, DBYA, DGEA, DJKA, DKJA, DKLA, DKLB, DKRF
	50 007 026	76,5	CFNA, CLSA		331165	81	CXEB, CXEC, CXFA, CXGA, CXGB, CXGD, CXHA, CXHB, CXHC, DAUA, DAUB, DAVA, DSRA, DSRB
	50 007 034	76,5	BLF		331166	81	CXEB, CXEC, CXFA, CXGA, CXGB, CXGD, CXHA, CXHB, CXHC, DAUA, DAUB, DAVA, DSRA, DSRB
	50 007 035	76,5	BLF		398000	74,5 74,51 76,5	CHYA, CHYB, CHYC, CZEA, DAFA, DFNA, DFNB, DSGB CPGA CWVA, CWVB
	50 007 056	76,5	CAXA, CAXC		398001	74,5	CHYA, CHYB, CHYC, CZEA, DAFA, DFNA, DFNB, DSGB
	50 007 634	82,5	BZB, CDAA, CDAB		81-25116	108	D 0834 LFL 63, D 0834 LFL 64, D 0834 LFL 65, D 0836 LFL 64, D 0836 LOH 64
	50 007 635	82,5	BZB, CDAA, CDAB		81-33115	79,5 81	AJM, ARL, ATD, ATJ, AVB, AXR, BEW, BKC, BLS, BXE BMM, BRT
<b>VOLKSWAGEN</b>					331156	71	CJZA, CJZB, CJZC, CJZD, CYVA, CYVB, CYVC, CYVD
	331157	71	CJZA, CJZB, CJZC, CJZD, CYVA, CYVB, CYVC, CYVD		81-33116	79,5	CAYA, CAYB, CAYC, CAYD, CAYE, CFWA, CLHA, CLHB, CLNA, CRKA, CRKB, CUSA, CUSB, CUTA, CXXA, CXXB, DBKA, DCXA, DGDB
	331158	74,5 82,5	CHPA, CHPB, CHZA, CHZB, CHZC, CHZD, CHZG, CHZJ, CHZK, CHZL, CMBA, CNLA, CPTA, CRJA, CUKA, CUKB, CUKC, CXSA, CZCA, CZCB, CZDA, CZDB, CZDC, CZDD, CZTA, DBYA, DGEA, DJKA, DKJA, DKLA, DKLB, DKRF CCZC		81-33117	81 79,5	CFCA CAYA, CAYB, CAYC, CAYD, CAYE, CFWA, CLHA, CLHB, CLNA, CRKA, CRKB, CUSA, CUSB, CUTA, CXXA, CXXB, DBKA, DCXA, DGDB
	331159	74,5 82,5	CHPA, CHPB, CHZA, CHZB, CHZC, CHZG, CHZK, CHZL, CMBA, CNLA, CPTA, CRJA, CUKA, CUKB, CUKC, CXSA, CZCA, CZCB, CZDA, CZDB, CZDC, CZDD, CZTA CCZC			81	CFCA
	331160	82,5 84,5	CHHA, CHHB, CJXA, CJXB, CJXC, CJXD, CJXE, CJXG, CNTA, CPLA, CPPA, CULC, CXCA, CXCB, CXDA, CYFB, DJHA, DJHB, DJHC, DJJA, DKTB, DLBA, DLRA, DLRB, DMFA, DNJA, DNUA CGEA, CGFA, CJTA, CYJA				

NEW

PG	KS-No.			PG	KS-No.						
	<b>81-33118</b>	67,1	ALD, ANV, ATE, AUC		<b>81-33121</b>	67,1	ALD, ANV, ATE, AUC				
		71	CBZA, CBZB, CBZC, CJZA, CJZB, CJZD, CYVA, CYVB			71	CBZA, CBZB, CBZC, CJZA, CJZB, CJZD, CYVA, CYVB				
		76,5	AFH, AFK, AHW, AJV, AKK, AKP, AKQ, ANM, ANW, APE, AQQ, ARC, ARR, ATN, AUA, AUB, AUD, AUS, AVY, AWY, AXP, AXU, AZD, AZQ, BAD, BAG, BAH, BBM, BBY, BBZ, BCA, BCB, BKG, BKY, BLF, BLG, BLM, BLN, BLP, BMD, BME, BMY, BTS, BUD, BWK, BZG, CAVA, CAVB, CAVC, CAVD, CAVE, CAXA, CFNA, CFNB, CGGA, CGGB, CGPA, CGPB, CHFA, CHFB, CJLA, CKMA, CLPA, CLRA, CLSA, CMSB, CNWA, CNWB, CTHA, CTHB, CTHC, CTHD, CTHE, CTKA			76,5	AFH, AFK, AHW, AJV, AKK, AKP, AKQ, ANM, ANW, APE, AQQ, ARC, ARR, ATN, AUA, AUB, AUD, AUS, AVY, AWY, AXP, AXU, AZD, AZQ, BAD, BAG, BAH, BBM, BBY, BBZ, BCA, BCB, BKG, BKY, BLF, BLG, BLM, BLN, BLP, BMD, BME, BMY, BTS, BUD, BWK, BZG, CAVA, CAVB, CAVC, CAVD, CAVE, CAXA, CFNA, CFNB, CGGA, CGGB, CGPA, CGPB, CHFA, CHFB, CJLA, CKMA, CLPA, CLRA, CLSA, CMSB, CNWA, CNWB, CTHA, CTHB, CTHC, CTHD, CTHE, CTKA				
		77	122, 122/2			77	122, 122/2				
		81	ADR, AEB, AFY, AGN, AGU, AJH, ALZ, ANB, APH, APT, APU, AQA, AQP, ARG, ARX, ARZ, AUE, AUM, AUQ, AVC, AVU, AWC, AWM, AWP, AWT, AWU, AWV, AYD, BAF, BBU, BGU, BJX, BKF, BNU			81	ADR, AEB, AFY, AGN, AGU, AJH, ALZ, ANB, APH, APT, APU, AQA, AQP, ARG, ARX, ARZ, AUE, AUM, AUQ, AVC, AVU, AWC, AWM, AWP, AWT, AWU, AWV, AYD, BAF, BBU, BGU, BJX, BKF, BMR, BNU				
		82,5	ACK, AGE, ALG, ALT, AMX, APR, AQD, ATQ, ATX, AXW, AXX, BBG, BGP, BGQ, BLR, BLX, BLY, BPR, BPS, BPY, BTK, BVX, BVY, BVZ, BWA, BYD, BZB, CAWA, CAWB, CBFA, CBTA, CBUA, CCA, CCTA, CCTB, CCZA, CCZB, CCZC, CCZD, CDAA, CDAB, CDLA, CDLC, CDLF, CDLJ, CFPA, CGYA, CHHA, CHHB, CJKA, CJKB, CJSA, CJSB, CJXC, CNSB, CPKA, CPRA, CXBA, CXBB, CYFB, DAJA, DAJB, DEDA			82,5	ACK, AGE, ALG, ALT, AMX, APR, AQD, ATQ, ATX, AXW, AXX, BBG, BGP, BGQ, BLR, BLX, BLY, BPR, BPS, BPY, BTK, BVX, BVY, BVZ, BWA, BYD, BZB, CAWA, CAWB, CBFA, CBTA, CBUA, CCA, CCTA, CCTB, CCZA, CCZB, CCZC, CCZD, CDAA, CDAB, CDLA, CDLC, CDLF, CDLJ, CFPA, CGYA, CHHA, CHHB, CJKA, CJKB, CJSA, CJSB, CJXC, CNSB, CPKA, CPRA, CXBA, CXBB, CYFB, DAJA, DAJB, DEDA				
		84,5	BAR, CGNA, CJTA			84,5	BAR, CGNA, CJTA				
			<b>81-33119</b>			84	AYT, AZZ, BAA, BDL, BFH, BKJ, BKK, BKL, BML, BMV, BMX, BRJ, BRK, BUB, CBRA, CFLA, CPFA		<b>81-33120</b>	84	AYT, AZZ, BAA, BDL, BFH, BKJ, BKK, BKL, BML, BMV, BMX, BRJ, BRK, BUB, CBRA, CFLA, CPFA
						86	AXZ			86	AXZ
						89	BHK, BLV, BWS, CDVA, CGRA, CHNA, CMTA, CMVA, CNNA			89	BHK, BLV, BWS, CDVA, CGRA, CHNA, CMTA, CMVA, CNNA

**NEW**



PG	KS-No.			PG	KS-No.				
	<b>81-33122</b>	67,1	ALD, ANV, ATE, AUC		<b>81-3324</b>	78,3	BAU, BDG, BDH		
		71	CBZA, CBZB, CBZC, CJZB			83	BKS, BMK, BSP, BUN, CARA, CARB, CASA, CASB, CASC, CASD, CATA, CEXA, CEXB, CEZA, CKDA		
		76,5	AFH, AFK, AHW, AJV, AKK, AKP, AKQ, ANM, ANW, APE, AQQ, ARC, ARR, ATN, AUA, AUB, AUD, AUS, AVY, AWY, AXP, AXU, AZD, AZQ, BAD, BAG, BAH, BBM, BBY, BBZ, BCA, BCB, BKG, BKY, BLF, BLG, BLM, BLN, BLP, BMD, BME, BMY, BTS, BUD, BWK, BZG, CAVA, CAVB, CAVC, CAVD, CAVE, CAXA, CFNA, CFNB, CGGA, CGGB, CGPA, CGPB, CHFA, CHFB, CJLA, CKMA, CLPA, CLRA, CLSA, CMSB, CNWA, CNWB, CTHA, CTHB, CTHC, CTHD, CTHE, CTKA			84	BDN, BDP		
		77	122, 122/2			81	CRVC		
		81	ADR, AEB, AFY, AGN, AGU, AJH, ALZ, ANB, APH, APT, APU, AQA, AQP, ARG, ARX, ARZ, AUE, AUM, AUQ, AVC, AVU, AWC, AWM, AWP, AWT, AWU, AWV, AYD, BAF, BBU, BGU, BJX, BKF, BMR, BNU			<b>81-51000</b>	81	CRVC	
		82,5	ACK, AGE, ALG, ALT, AMX, APR, AQD, ATQ, ATX, AXW, AXX, BBG, BGP, BGQ, BLR, BLX, BLY, BPR, BPS, BPY, BTK, BVX, BVY, BVZ, BWA, BYD, BZB, CAWA, CAWB, CBFA, CBTA, CBUA, CCCA, CCTA, CCTB, CCZA, CCZB, CCZC, CCZD, CDAA, CDAB, CDLA, CDLC, CDLF, CDLJ, CFPA, CGYA, CHHA, CHHB, CJKA, CJKB, CJSA, CJSB, CJXC, CNSB, CYFB, DAJA, DAJB, DEDA			<b>81-51001</b>	81	CRVC	
		84,5	BAR, CGNA, CJTA			<b>50 006 344</b>	78,3	BAU, BDG, BDH	
		<b>81-33123</b>	71			CJZA, CJZB, CYVA, CYVB	<b>50 006 345</b>	78,3	BAU, BDG, BDH
			74,5			CHYA, CHYB, CHYC, CHZD, CPTA, CZEA, DAFA, DFNA, DFNB, DSGB	<b>50 006 346</b>	78,3	BAU, BDG, BDH
			74,51			CPGA	<b>50 006 347</b>	78,3	BAU, BDG, BDH
		<b>81-33124</b>	76,5			CWVA, CWVB	<b>50 007 018</b>	76,5	BLG, BMY, CAVA, CAVB, CAVC, CAVD, CAVE, CAXA, CKMA, CMSB, CNWA, CTHA, CTHD, CTHE, CTKA
			71			CJZA, CJZB, CYVA, CYVB	<b>50 007 019</b>	76,5	CAVA, CAVB, CAVC, CAVD, CAVE, CKMA, CNWA, CTHA, CTHD, CTKA
		<b>81-33125</b>	74,5			CHYA, CHYB, CHYC, CHZD, CPTA, CZEA, DAFA, DFNA, DFNB, DSGB	<b>50 007 020</b>	79,5	CAYB, CAYC, CAYD, CLNA
			74,51			CPGA	81	CAAA, CAAB, CAAC, CAAD, CAAE, CBAA, CBAB, CBBB, CBDA, CBDB, CCHA, CCHB, CDBA, CDCA, CEGA, CFCA, CFFA, CFFB, CFFD, CFFE, CFGB, CFGC, CFHB, CFHC, CFHE, CFHF, CFJA, CJAA, CKTB, CKTC, CKUB, CKUC, CLCA, CLCB, CLJA, CLLA, CNEA, CNFA, CNFB, CSHA	
		<b>81-33126</b>	76,5			CWVA, CWVB	<b>50 007 022</b>	79,5	CAYB, CAYC, CAYD, CLNA
81	BSE, BSF, CCSA		81	CAAA, CAAB, CAAC, CAAD, CAAE, CBAA, CBAB, CBBB, CBDA, CBDB, CCHA, CCHB, CDBA, CDCA, CEGA, CFCA, CFFA, CFFB, CFFD, CFFE, CFGB, CFGC, CFHC, CFHE, CFHF, CFJA, CJAA, CKTB, CKTC, CKUB, CKUC, CLCA, CLCB, CLJA, CLLA, CNEA, CNFA, CNFB, CSHA					
<b>81-3323</b>	78,3	BAU, BDG, BDH	<b>50 007 025</b>	76,5	CFNA, CFNB, CLRA, CLSA				
	83	BKS, BMK, BSP, BUN, CARA, CARB, CASA, CASB, CASC, CASD, CATA, CEXA, CEXB, CEZA, CJGD, CJMA, CKDA, CNRB, CRCA, CRCD, CVVA, CVWA	<b>50 007 026</b>	76,5	CFNA, CFNB, CLRA, CLSA				
	84	BDN, BDP	<b>50 007 034</b>	76,5	BLF, BLP				
			<b>50 007 035</b>	76,5	BLF, BLP				

NEW

PG	KS-No.			PG	KS-No.			
	50 007 039	76,5	BKG		471206	81	B 5204 T5, B 5204 T8, B 5204 T9, B 6284 T, B 6284 T2	
	50 007 040	76,5	BKG			83	B 5254 T10, B 5254 T12, B 5254 T14, B 5254 T2, B 5254 T3, B 5254 T4, B 5254 T6, B 5254 T7, B 6294 S, B 6294 S2, B 6294 T, B 6294 S3	
	50 007 056	76,5	CAXA, CMSB			471207	81	B 5204 T5, B 5204 T8, B 5204 T9, B 6284 T, B 6284 T2
	50 007 634	82,5	BZB, CDAA, CDAB, CGYA				83	B 5254 T10, B 5254 T12, B 5254 T14, B 5254 T2, B 5254 T3, B 5254 T4, B 5254 T6, B 5254 T7, B 6294 S, B 6294 S2, B 6294 T, B 6294 S3
	50 007 635	82,5	BZB, CDAA, CDAB, CGYA			471209	81	B 5204 T5, B 5204 T8, B 5204 T9, B 6284 T, B 6284 T2
<b>VOLVO</b>					83		B 5254 T10, B 5254 T12, B 5254 T14, B 5254 T2, B 5254 T3, B 5254 T4, B 5254 T6, B 5254 T7, B 6294 S, B 6294 S2, B 6294 T, B 6294 S3	
	471200	82	B 4204 T11, B 4204 T14, B 4204 T15, B 4204 T17, B 4204 T19, B 4204 T20, B 4204 T21, B 4204 T23, B 4204 T26, B 4204 T31, B 4204 T37, B 4204 T38, B 4204 T44		471210	82	B 4204 T11, B 4204 T14, B 4204 T15, B 4204 T17, B 4204 T19, B 4204 T20, B 4204 T21, B 4204 T23, B 4204 T26, B 4204 T31, B 4204 T37, B 4204 T38, B 4204 T44	
		83	B 4204 T5			83	B 4204 T5	
		87,5	B 4204 T6, B 4204 T7			87,5	B 4204 T6, B 4204 T7	
	471202	82	D 4204 T11, D 4204 T12, D 4204 T14, D 4204 T16, D 4204 T20, D 4204 T23, D 4204 T4, D 4204 T5, D 4204 T6, D 4204 T7, D 4204 T8, D 4204 T9		48335	110	D5K240, D8K250, D8K280, D8K320, D8K350, TAD540VE, TAD541VE, TAD542VE, TAD550VE, TAD551VE, TAD552VE, TAD570VE, TAD571VE, TAD572VE, TAD840VE, TAD841VE, TAD842VE, TAD843VE, TAD851VE, TAD852VE, TAD853VE, TAD870VE, TAD871VE, TAD872VE, TAD873VE	
	471203	82	D 4204 T11, D 4204 T12, D 4204 T14, D 4204 T16, D 4204 T20, D 4204 T23, D 4204 T4, D 4204 T5, D 4204 T6, D 4204 T7, D 4204 T8, D 4204 T9			48336	110	D5K240, D8K250, D8K280, D8K320, D8K350, TAD540VE, TAD541VE, TAD542VE, TAD550VE, TAD551VE, TAD552VE, TAD570VE, TAD571VE, TAD572VE, TAD840VE, TAD841VE, TAD842VE, TAD843VE, TAD851VE, TAD852VE, TAD853VE, TAD870VE, TAD871VE, TAD872VE, TAD873VE
	471204	81	D 5204 T, D 5204 T2, D 5204 T3, D 5204 T4, D 5204 T5, D 5204 T6, D 5204 T7, D 5244 T, D 5244 T10, D 5244 T11, D 5244 T12, D 5244 T13, D 5244 T14, D 5244 T15, D 5244 T16, D 5244 T17, D 5244 T18, D 5244 T19, D 5244 T2, D 5244 T20, D 5244 T21, D 5244 T22, D 5244 T23, D 5244 T3, D 5244 T4, D 5244 T5, D 5244 T6, D 5244 T7, D 5244 T8, D 5244 T9, D 5244 T3		48337		131	D13K420, D13K460, D13K500, D13K540
	471205	81	D 5204 T, D 5204 T2, D 5204 T3, D 5204 T4, D 5204 T5, D 5204 T6, D 5204 T7, D 5244 T, D 5244 T10, D 5244 T11, D 5244 T12, D 5244 T13, D 5244 T14, D 5244 T15, D 5244 T16, D 5244 T17, D 5244 T18, D 5244 T19, D 5244 T2, D 5244 T20, D 5244 T21, D 5244 T22, D 5244 T23, D 5244 T3, D 5244 T4, D 5244 T5, D 5244 T6, D 5244 T7, D 5244 T8, D 5244 T9, D 5244 T3			539046	75	D 4162 T
					539047	75	D 4162 T	
					81-18111	75	D 4162 T, D 4164 T	

**NEW**

PG	KS-No.			PG	KS-No.			
	81-18113	79	B 4164 T2, B 4164 T4		120	TAD 1030 GE, TAD 1032 GE		
	81-22114	98	TAD660VE			120,65	D 100 A, D 100 B, D10A320, D10A360, D10B320, D10B360, DH10A245, DH10A285, DH10A360, HD 100 D, TD 100 A, TD 100 B, TD 100 BG, TD 100 C, TD 100 CHC, TD 100 F, TD 100 G, TD 100 GA, TD 101 F, TD 101 FA, TD 101 FC, TD 101 FD, TD 101 G, TD 101 GA, TD 101 GB, TD 101 GE, TD 102 F, TD 102 FAQ, TD 102 FBQ, TD 102 FCQ, TD 102 FD, TD 102 FDQ, TD 102 FEQ, TD 102 FF, TD 102 FGQ, TD 102 FH, TD 102 FL, TD 102 FM, TD 102 FO, TD 102 FS, TD 102 FT, TD 103 E, TD 103 EA, TD 103 ES, TD 103 KB, TD 103 KF, THD 100 A, THD 100 D, THD 100 DA, THD 100 DB, THD 100 DC, THD 100 DD, THD 100 E, THD 100 EA, THD 100 EB, THD 100 EC, THD 100 ED, THD 100 EE, THD 100 EK, THD 101 B, THD 101 GB, THD 101 GC, THD 101 GD, THD 101 KB, THD 101 KC, THD 101 KE, THD 102 KA, THD 102 KB, THD 102 KD, THD 102 KE, THD 102 KF, THD 102 KJ, THD 103 E, THD 103 ES, THD 103 KB, THD 103 KD, THD 103 KF, D 10 A 245, D 10 A 310, D 10 A 350, D 10 C 320, D 10 C 360, D 100 BHC, D 100 BRC, D 100 HC, DH 10 A 340, DH 10 A 350, MD 100 A, MD 100 B, TAMD 102 A, TAMD 102 D, TAMD 103 A-A, TD 100 AG, TD 100 AHC, TD 100 ARC, TD 100 GG, TD 100 HC, TD 101 GG, TD 101 KC, TD 101 MC, TD 103 KAE, TD 103 ME, TD 104 KAE, THD 100, THD 101 G, THD 101 K, THD 101 MC, TMD 100 A, TMD 102 A, TMD 102 C	
		101	TAD650VE					
	81-33118	88,9	B 204 FT					
	81-33121	88,9	B 204 FT					
	81-33122	88,9	B 204 FT					
	81-47121	81	D 5244 T, D 5244 T2, D 5244 T4, D 5244 T5, D 5244 T8					
81-47123	110	D5K240, D8A1-A MP, D8A4-A MP, D8K250, D8K280, D8K320, D8K350, TAD 850 VE, TAD 880 VE, TAD 881 VE, TAD 882 VE, TAD 883 VE, TAD 884 VE, TAD540VE, TAD541VE, TAD542VE, TAD550VE, TAD551VE, TAD552VE, TAD570VE, TAD571VE, TAD572VE, TAD840VE, TAD841VE, TAD842VE, TAD843VE, TAD851VE, TAD852VE, TAD853VE, TAD870VE, TAD871VE, TAD872VE, TAD873VE						
					130	TD 122 F		
					130,17	TD 121 F, TD 121 G, TD 121 GD, TD 122 FS		

NEW

PG	KS-No.			PG	KS-No.		
	92-22019	108	D7E 240, D7E 280, D7E 290, D7E 320, TAD560VE, TAD561VE, TAD734GE, TAD752GE, TAD753GE, TAD754GE, TAD761VE, TAD762VE, TAD763VE, TAD764VE, TAD765VE, D7E 360		92-47028	131	D13A360, D13A400, D13A440, D13A480, D13A520, D13B360, D13B400, D13B440, D13B500, D13C1-A MG, D13C1-A MH, D13C1-A MP, D13C2-A MG, D13C2-A MH, D13C2-A MP, D13C380, D13C420, D13C460, D13C500, D13C540, D 13 C 380 EURO5, D 13 C 420 EURO5, D 13 C 460 EURO5, D 13 C 500 EURO5, D13B-A MP, D13B-B MP, D13B-C MP, D13B-D MP, D13B-E MG, D13B-E MH, D13B-F MG, D13B-G MP, D13B-H MP, D13B-J MP, D13B-K MP, D13B-L MP, D13B-M MP, D13B-N MH
	92-22020	108	D7E 240, D7E 280, D7E 290, D7E 320, TAD560VE, TAD561VE, TAD734GE, TAD752GE, TAD753GE, TAD754GE, TAD761VE, TAD762VE, TAD763VE, TAD764VE, TAD765VE, D7E 360		92-47029	131	D13A360, D13A400, D13A440, D13A480, D13A520, D13B360, D13B400, D13B440, D13B500, D13C1-A MG, D13C1-A MH, D13C1-A MP, D13C2-A MG, D13C2-A MH, D13C2-A MP, D13C380, D13C420, D13C460, D13C500, D13C540, D 13 C 380 EURO5, D 13 C 420 EURO5, D 13 C 460 EURO5, D 13 C 500 EURO5, D13B-A MP, D13B-B MP, D13B-C MP, D13B-D MP, D13B-E MG, D13B-E MH, D13B-F MG, D13B-G MP, D13B-H MP, D13B-J MP, D13B-K MP, D13B-L MP, D13B-M MP, D13B-N MH
	92-47008	130	TD 122 F		92-47030	89	MD 11
		130,17	TD 121 F, TD 121 G, TD 121 GD, TD 122 FS, TWD 1210 V			123	D 11 A-C, D 11 A-C (IPS), D 11 A-C MP, D 11 A-D (IPS), D 11 A-D MP, D 11 A-E, D 11 A-E MP, D11A-370, D11A430, D11B1-A MP, D11B2-A MP, D11B3-A MP, D11B4-A MP, D11C330, D11C370, D11C410, D11C450, D11K330, D11K370, D11K380, D11K410, D11K430, D11K450, D11K460, TAD1140VE, TAD1141VE, TAD1142VE, TAD1150VE, TAD1151VE, TAD1152VE, TAD1170VE, TAD1171VE, TAD1172VE, D 11 A-A, D 11 A-B
		130,175	TAD 120 BHC, TAD 121 CHC, TAD 1230 G, TD 120 A, TD 120 C, TD 120 D, TD 120 E, TD 120 F, TD 120 FA, TD 120 FB, TD 120 FC, TD 120 FTQ, TD 120 G, TD 120 GA, TD 121 FA, TD 121 FB, TD 121 FC, TD 121 FD, TD 121 FE, TD 121 FF, TD 121 FG, TD 121 FH, TD 121 FK, TD 122 ED, TD 122 FA, TD 122 FAQ, TD 122 FBQ, TD 122 FCQ, TD 122 FK, TD 122 FKQ, TD 122 FR, TD 122 FTO, TD 122 KBE, TD 122 KE, TD 122 KHD, TD 123 EA, TD 123 EB, TD 123 EC, TD 123 ED, TAMD 120 A, TAMD 120 AK, TAMD 120 B, TAMD 120 BCC, TAMD 121 C, TAMD 121 D, TAMD 122 A, TAMD 122 C, TAMD 122 D, TAMD 122 P-A, TAMD 122 P-B, TAMD 122 P-C, TD 120 GG, TD 121 A, TD 121 GG, TD 121 GP, TD 1210 G, TD 122 F (USA), TD 122 GA, TD 122 GB, TD 122 GH, TD 123 F, TID 120 FG, TID 121 FG, TID 121 KG, TID 121 KGP, TID 121 KP, TID 121 KPB, TID 121 LG, TID 121 LGP, TID 121 LP, TMD 120 A, TMD 120 B, TMD 121 C, TMD 122 A, TWD 1210 G, TWD 1210 P, TWD 1211 G, TWD 1211 P, TWD 1211 V, TWD 1230 VE, TWD 1231 VE				
		130,18	TD 122 FH, TD 122 FL, TD 123 E, TD 123 ES				

NEW



PG	KS-No.			PG	KS-No.		
     	92-47031	89	MD 11				
		123	D 11 A-C, D 11 A-C (IPS), D 11 A-C MP, D 11 A-D (IPS), D 11 A-D MP, D 11 A-E, D 11 A-E MP, D11A-370, D11A430, D11B1-A MP, D11B2-A MP, D11B3-A MP, D11B4-A MP, D11C330, D11C370, D11C410, D11C450, D11K330, D11K370, D11K380, D11K410, D11K430, D11K450, D11K460, TAD1140VE, TAD1141VE, TAD1142VE, TAD1150VE, TAD1151VE, TAD1152VE, TAD1170VE, TAD1171VE, TAD1172VE, D 11 A-A, D 11 A-B				
	20100412005	131	D12C340, D12C380, D12C420, D12C460				
	20100413000	131	D13A360, D13A400, D13A440, D13A480, D13A520				
	50 007 093	75	D 4164 T				
	50 007 094	75	D 4164 T				

NEW

# LIST OF MANUFACTURERS

<b>D</b>	<b>HERSTELLERVERZEICHNIS</b>
<b>E</b>	<b>LIST OF MANUFACTURERS</b>
<b>F</b>	<b>TABLEAU DES CONSTRUCTEURS</b>
<b>ES</b>	<b>ÍNDICE DEL FABRICANTE</b>
<b>RU</b>	<b>ПЕРЕЧЕНЬ ИЗГОТОВИТЕЛЕЙ</b>

# LIST OF MANUFACTURERS

	Page		Page
<b>A</b>			
AGRIA .....	942	POLSKI-FIAT .....	196
ALPINA .....	142		
AUSTIN (BLMC) .....	1021	<b>R</b>	
AUTOBIANCHI .....	347	RENAULT .....	942
		ROVER .....	1021
<b>B</b>			
BMW .....	142	<b>S</b>	
<b>C</b>			
CASE .....	366	SKODA .....	1026
CLAAS .....	260	SKODA SVW .....	1026
.....	366	STEYR .....	366
.....	1081	<b>U</b>	
		UNIC .....	196
		UTB .....	196
<b>D</b>			
DACIA .....	942	<b>V</b>	
DETROIT DIESEL .....	366	VOLKSWAGEN .....	1081
		VOLVO .....	1283
<b>F</b>			
FAHR .....	260	VOLVO-BM .....	1283
.....	366	VW FAW .....	1081
.....	1081	VW SVW .....	1081
FAUN .....	260		
FIAT .....	196		
FIATALLIS .....	366		
FORD .....	260		
FORDSON .....	260		
<b>I</b>			
IHC-CASE (CNH) .....	366		
INFINITI .....	920		
IVECO .....	196		
<b>K</b>			
KOMATSU .....	366		
KÄSSBOHRER .....	366		
<b>L</b>			
LANCIA .....	347		
LAND ROVER .....	1021		
LIEBHERR .....	366		
<b>M</b>			
MERCEDES-BENZ .....	366		
MWB .....	366		
<b>N</b>			
NEW HOLLAND .....	196		
.....	260		
.....	366		
NISSAN .....	920		
<b>O</b>			
OM .....	196		

<b>D</b>	<b>PRODUKTPROGRAMM</b>
<b>E</b>	<b>PRODUCT RANGE</b>
<b>F</b>	<b>GAMME DE PRODUITS</b>
<b>ES</b>	<b>PROGRAMA DE PRODUCTOS</b>
<b>RU</b>	<b>ПРОИЗВОДСТВЕННЫЙ АССОРТИМЕНТ</b>





	Cyl.	Cyl. Diagram	Cyl. mm	cm <sup>3</sup>	Comp. Ratio $\epsilon$	kW	PS	Pos	
<b>B</b> 1.0L (44 kW)	B	2	94 x 70,6	980	2	8,5:1	44-47	60-65	<b>95</b>
1.0L (48 kW)	B	2	94 x 70,6	980	2	9,5:1	48-52	65-70	<b>96</b>
114/2	B	4	84 x 71	1573	2	9,5:1	77	105	<b>33</b>
116	B	4	84 x 71	1573	2	8,6	61-63	83-85	<b>33</b>
118,3 KH	B	4	89 x 71	1766	2	8,6:1	66	90	<b>84</b>
121	B	4	89 x 80	1990	2	8,5:1	74	100	<b>77</b>
247/60	B	2	90 x 70,6	898	2	9:1	44	60	<b>85</b>
247/67	B	2	90 x 70,6	898	2	9,5:1	49	67	<b>85</b>
B37 C15 Euro 6	D (A)	3	84 x 90	1496	4	16,5:1	70-85	95-116	<b>62</b>
B37 C15 A Euro 6	D (A)	3	84 x 90	1496	4	16,5	70-85	95-116	<b>63</b>
B37 D15 A Euro 6	D (A)	3	84 x 90	1496	4	16,5	70-85	95-116	<b>63</b>
B38 A15 A Euro 6	B (A)	3	82 x 94,6	1499	4	11,0:1	75-103	102-140	<b>25</b>
B38 B15 Euro 6	B (A)	3	82 x 94,6	1499	4	11,0:1	100	136	<b>25</b>
B38 B15 A	B (A)	3	82 x 94,6	1499	4	11	80-100	109-136	<b>27</b>
B38 K15 A	B (A)	3	82 x 94,6	1499	4		170	231	<b>24</b>
B46 A20 B	B (A)	4	82 x 94,6	1998	4	11	170	231	<b>26</b>
B47 C20 A Euro 6	D (A)	4	84 x 90	1995	4	16,5	100-140	136-190	<b>63</b>
B47 C20 B	D (A)	4	84 x 90	1995	4	16,5	100-170	136-231	<b>64</b>
B47 D20 A Euro 6	D (A)	4	84 x 90	1995	4	16,5	85-155	116-211	<b>63</b>
B47 D20 B	D (A)	4	84 x 90	1995	4	16,5	85-170	116-231	<b>64</b>
B48 A20 A	AB (A)	4	82 x 94,6	1998	4	11	120-170	163-231	<b>30</b>
B48 A20 B Euro 6	AB (A)	4	82 x 94,6	1998	4	11	141-195	192-265	<b>30</b>
B48 B20 Euro 6	B (A)	4	82 x 94,6		4		170	231	<b>25</b>
B48 B20 A	AB (A)	4	82 x 94,6	1998	4	10,2	115-190	156-258	<b>31</b>
B48 B20 B	B (A)	4	82 x 94,6	1998	4		120-195	163-265	<b>26</b>
B57 D30 A	D (A)	6	84 x 90	2993	4		155-235	211-320	<b>63</b>
B57 D30 B	D (A)	6	84 x 90	2993	4		155-250	211-340	<b>62</b>
B57 D30 C	D (A)	6	84 x 90	2993	4		294	400	<b>65</b>
B58 B30 A Euro 6	B (A)	6	82 x 94,6	2998	4	11	239-265	325-360	<b>26</b>
Boxermotor B2	B	2	101 x 73	1170		12,5:1	81	110	<b>97</b>
K 589 74 kW	B	4	67 x 70	987	4	11:1	74	100	<b>1</b>
K1200 (4ZYL. REIHE)	B	4	79 x 59	1157	4	13,0:1	120-123	160-167	<b>7</b>
M10 B16 (164VA)	B (NA)	4	84 x 71	1573	2	8-9,5	55-77	75-105	<b>33</b>
M10 B16 (164VB)	B (NA)	4	84 x 71	1573	2	8-9,5	55-77	75-105	<b>33</b>
M10 B16 (16A)	B (NA)	4	84 x 71	1573	2	8-9,5	55-77	75-105	<b>33</b>
M10 B16 N	B	4	84 x 71	1573	2	8:1	55	75	<b>33</b>
M10 B16 V	B	4	84 x 71	1573	2	9,5:1	55	75	<b>33</b>
M10 B18	B (NA)	4	89 x 71	1766	2	8,2-9,5	66-77	90-105	<b>77</b>
M10 B18 (184EA)	B (NA)	4	89 x 71	1766	2	8,2-9,5	66-77	90-105	<b>77</b>
M10 B18 (184EB)	B (NA)	4	89 x 71	1766	2	8,2-9,5	66-77	90-105	<b>77</b>
M10 B18 (184KA)	B (NA)	4	89 x 71	1766	2	8,2-9,5	66-77	90-105	<b>77</b>
M10 B18 (184VA)	B (NA)	4	89 x 71	1766	2	8,2-9,5	66-77	90-105	<b>77</b>
M10 B18 (184VB)	B (NA)	4	89 x 71	1766	2	8,2-9,5	66-77	90-105	<b>77</b>
M10 B18 (184VC)	B (NA)	4	89 x 71	1766	2	8,2-9,5	66-77	90-105	<b>77</b>
M10 B18 (184VD)	B (NA)	4	89 x 71	1766	2	8,2-9,5	66-77	90-105	<b>77</b>
M10 B18 K	B	4	89 x 71	1767	2	8,8-10	75-77	102-105	<b>77</b>
M10 B18 S	B	4	89 x 71	1767	2	9,5:1	66	90	<b>84</b>
M10 B18 V	B	4	89 x 71	1767	2	9,5:1	66	90	<b>84</b>
M10 B20	B (NA)	4	89 x 80	1990	2	8,1-9,5	74-101	101-137	<b>77</b>
M20 B20	B (NA)	6	80 x 66	1990	2	8,8-9,9	90-110	122-150	<b>8</b>
M20 B20 L	B	6	80 x 66	1991	2	9,4:1	92	125	<b>8</b>
M20 B20 LE	B	6	80 x 66	1991	2	9,8:1	95	129	<b>8</b>
M20 B20 M0.E8	B	6	80 x 66	1991	2	9,4:1	95	129	<b>12</b>
M20 B23 K	B	6	80 x 76,8	2316	2	9,5:1	105	143	<b>8</b>
M20 B23 L	B	6	80 x 76,8	2316	2	9,8:1	110	150	<b>8</b>
M20 B23 LE	B	6	80 x 76,8	2316	2	9,8:1	102	109	<b>8</b>
M20 B25 M.E	B	6	84 x 75	2494	2	9,4:1	125	170	<b>50</b>
M20 B25 M.E/8	B	6	84 x 75	2494	2	9,4:1	125	170	<b>50</b>
M20 B25 M1.Z7	B	6	84 x 75	2494	2	8,8:1	125	170	<b>50</b>
M20 B27 ME.U	B	6	84 x 81	2693	2	9:1	90	122	<b>34</b>
M20 B27 MEE	B	6	84 x 81	2693	2	10,2-11	92	125	<b>34</b>
M21 D24 (246DA)	D (NA)	6	80 x 81	2443	2	22	63	86	<b>14</b>
M21 D24 (246TA)	D (A)	6	80 x 81	2443	2	22	85	115	<b>14</b>
M21 D24 (246TB)	D (A)	6	80 x 81	2443	2	22	85	115	<b>14</b>
M21 D24 W	D (NA)	6	80 x 81	2443	2	22:1	63	86	<b>17</b>
M21 D24 WA	D (A)	6	80 x 81	2443	2	22:1	85	115	<b>17</b>
M30 B25	B (NA)	6	86 x 71,6	2494	2	9-9,6	107-125	145-170	<b>75</b>
M30 B25 L	B	6	86 x 71,6	2494	2	9,6:1	110	150	<b>75</b>
M30 B28	B (NA)	6	86 x 80	2788	2	9-9,3	121-141	165-192	<b>75</b>

		Cyl.	mm	cm <sup>3</sup>		Comp. Ratio $\epsilon$	kW	PS	Pos
M30 B28 L	B	6	86 x 80	2788	2	8,2-9,3	126-135	171-184	75
M30 B30	B (NA)	6	89 x 80	2986	2	9-9,2	131-147	176-200	78
M30 B30 (306EA)	B (NA)	6	89 x 80	2986	2	9-9,2	131-147	178-200	78
M30 B30 (306KA)	B (NA)	6	89 x 80	2986	2	9-9,2	131-147	178-200	78
M30 B30 V	B	6	89 x 80	2986	2	9:1	132-136	180-185	78
M30 B32	B (NA)	6	89 x 86	3210	2	9-10	130-152	177-207	78
M30 B32 (315/1A)	B (NA)	6	89 x 86	3153	2	9,5	152	206	78
M30 B32 LA	B (LA)	6	89 x 86	3210	2	7/7,5:1	185	252	78
M30 B32 LU	B	6	89 x 86	3210	2	8/8,4:1	130-132	176-179	78
M30 B32 M	B	6	89 x 86	3210	2	10:1	145	197	78
M30 B34 M.45	B	6	92 x 86	3430	2	8:1	136	185	89
M30 B34 MA	B (LA)	6	92 x 86	3430	2	8:1	185	252	89
M30 B34 ME	B	6	92 x 86	3430	2	10:1	150-160	204-218	89
M30 B35 (L-Jetronic,	B (NA)	6	93,4 x 84	3453	2	10	160	218	92
M30 B35 (Motronic,10	B (NA)	6	92 x 86	3430	2	10	160	218	86
M30 B35 (Motronic,9.	B (NA)	6	92 x 86	3430	2	9,2	162	220	86
M40 B16 (164E1)	B (NA)	4	84 x 72	1596	2	9	73-75	99-102	36
M40 B16 C	B (NA)	4	84 x 72	1596	2	9:1	73-75	99-102	51
M40 B18 (184E1)	B (NA)	4	84 x 81	1796	2	8,8	83-85	113-116	35
M40 B18 C	B (NA)	4	84 x 81	1796	2	8,8	103	140	37
M40 B18 M.E	B	4	84 x 81	1796	2	8,8:1	83-85	113-115	35
M41 B17	D (LA)	4	80 x 82,8	1665	2	22:1	66	90	18
M41 D17 (174T1)	D (A)	4	80 x 82,8	1665	2	22	66	90	15
M42 B18 (184S1)	B (NA)	4	84 x 81	1796	4	10	100-103	136-140	38
M42 B18 TU1	B	4	84 x 81	1796	4	10:1	103	140	52
M43 B16 (164E2)	BG (NA)	4	84 x 72	1596	2	9,7	75-77	102-105	32
M43 B16 (164E3)	B (NA)	4	84 x 72	1596	2	9,7	77	105	41
M43 B18 (184E2) KAT	AB (NA)	4	84 x 81	1796	2	9,7	83-85	113-116	56
M43 B18 Gas KAT	GF	4	84 x 81	1796	2	9,7:1	85	115	58
M43 B19 TU OL	B	4	85 x 83,5	1895	2	9,7:1	87	118	69
M43 B19 TU UL	B	4	85 x 83,5	1895	2	9,7:1	77	105	69
M44 B19 (194S1)	B (NA)	4	85 x 83,5	1895	4	10	103	140	70
M47 D20 (204D1)	D (A)	4	84 x 88	1951	4	19	85-100	116-136	59
M47 D20 (204D4)	D (A)	4	84 x 90	1995	4	17	85-120	116-163	59
M47 D20 OL	D (LA)	4	84 x 88	1951	4	19:1	100	136	59
M47 D20 TU2	D (LA)	4	84 x 88	1951	4	19,0:1	90-120	122-163	59
M47 D20 TU2 OL	D (LA)	4	84 x 90	1995	4	17:1	120	163	59
M47 D20 TU2 UL Euro 4	D (LA)	4	84 x 90	1995	4	17:1	90	122	59
M47 D20 TU2 UL Euro 5	D (LA)	4	84 x 90	1995	4	16:1	105	143	59
M47 D20 UL Euro 3	D (LA)	4	84 x 88	1951	4	19:1	85	115	59
M47 D20 UL	D (LA)	4	84 x 90	1995	4	17:1	85	115	59
M47 D20TU OL	D (LA)	4	84 x 88	1951	4	19:1	100	136	59
M47 D20TU UL	D (LA)	4	84 x 88	1951	4	19:1	85	115	59
M47 D20TU2 OL	D (LA)	4	84 x 88	1951	4	17:1	110-120	150-163	59
M50 B20 (206S1)	B (NA)	6	80 x 66	1990	4	10,5	110	150	9
M50 B20 (206S2)	B (NA)	6	80 x 66	1990	4	11	110	150	9
M50 B20 M	B	6	80 x 66	1991	4	10,5:1	110	150	13
M50 B25 M	B	6	84 x 75	2494	4	10:1	141	192	53
M51 D25 (Inter.)	D (A)	6	80 x 82,8	2503	2	22:1	105	143	19
M51 D25 OL	D (LA)	6	80 x 82,8	2497	2	22:1	105	143	20
M51 D25 TU UL	D (A)	6	80 x 82,8	2497	2	22:1	85	115	21
M51 D25 UL	D (A)	6	80 x 82,8	2497	2	22:1	85	115	20
M52 B20 (206S3)	B (NA)	6	80 x 66	1990	4	11	100-110	136-150	10
M52 B20 (206S4)	B (NA)	6	80 x 66	1990	4	11	100-110	136-150	10
M52 B25 (256S3)	B (NA)	6	84 x 75	2494	4	10,2-10,5	120-141	163-192	40
M52 B25 (256S4)	B (NA)	6	84 x 75	2494	4	10,2-10,5	120-141	163-192	40
M52 B28 (286S1)	B (NA)	6	84 x 84	2793	4	10,2	141-143	192-194	40
M52 B28 (286S2)	B (NA)	6	84 x 84	2793	4	10,2	141-144	192-196	40
M54 256 S3	B	6	84 x 75	2494	4	10,5:1	141	192	40
M54 B22 (226S1)	B (NA)	6	80 x 72	2171	4	10,8	120-125	163-170	11
M54 B25 (256S5)	B (NA)	6	84 x 75	2494	4	10,5	137-141	186-192	40
M54 B30 (306S3)	B (NA)	6	84 x 89,6	2979	4	10,2	163-170	222-231	40
M57 306 D4	D (LA)	6	84 x 90	2993	4	16,5:1	200	272	59
M57 306 D5	D (LA)	6	84 x 90	2993	4	16,5:1	210	286	66
M57 D25 (256D1)	D (A)	6	80 x 82,8	2497	4	17,5	120	163	16
M57 D25 (256D2)	D (A)	6	80 x 82,8	2497	4	17	120-130	163-177	16
M57 D25 TU	D (LA)	6	84 x 82,8	2497	4	17:1	130	177	59

**B**

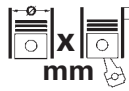
		Cyl.		mm	cm <sup>3</sup>	Comp. Ratio $\epsilon$	kW	PS	Pos
<b>B</b> M57 D30 (135 kW)	D (LA)	6	84 x 88	2926	4	18:1	135-142	184-193	<b>59</b>
M57 D30 (306D1)	D (A)	6	84 x 88	2926	4	17	135-142	184-193	<b>59</b>
M57 D30 (306D2)	D (A)	6	84 x 90	2993	4	17	150-160	204-218	<b>60</b>
M57 D30 (306D3)	D (A)	6	84 x 90	2993	4	17	135-173	184-235	<b>60</b>
M57 D30 (306D4)	D (A)	6	84 x 90	2993	4	16,5	198-200	269-272	<b>60</b>
M57 D30 (306D5)	D (A)	6	84 x 90	2993	4	16,5	198-221	269-301	<b>60</b>
M57 D30 N2	D (LA)	6	84 x 90	2993	4	17:1	173-210	231-286	<b>60</b>
M57 D30 TU	D (LA)	6	84 x 90	2993	4	17:1	150-160	204-218	<b>60</b>
M57 D30 TU TOP	D (LA)	6	84 x 90	2993	4	16,5:1	210-220	286-298	<b>67</b>
M57 D30 TU2 OL	D (LA)	6	84 x 90	2993	4	17:1	173	235	<b>59</b>
M57 D30 UL	D (LA)	6	84 x 90	2993	4	17:1	145	197	<b>59</b>
M60 B30 (308S1)	B (NA)	8	84 x 67,6	2997	4	10,5	155-160	211-218	<b>39</b>
M60 B40 (408S1)	B (NA)	8	89 x 80	3982	4	10	210	286	<b>79</b>
M62 B35 (358S1)	B (NA)	8	84 x 78,9	3498	4	10	173	235	<b>39</b>
M62 B35 (358S2)	B (NA)	8	84 x 78,9	3498	4	10	173-180	235-245	<b>39</b>
M62 B35 TU	B (NA)	8	84 x 78,9	3498	4	10:1	175-180	238-245	<b>39</b>
M62 B44 (448S1)	B (NA)	8	92 x 82,7	4398	4	10	210	286	<b>87</b>
M62 B44 (448S2)	B (NA)	8	92 x 82,7	4398	4	10	210	286	<b>87</b>
M62 B46 (468S1)	B (NA)	8	93 x 85	4619	4	10,5	255-261	347-355	<b>90</b>
M67 D39 (398D1)	D (A)	8	84 x 88	3901	4	18	180-190	245-258	<b>59</b>
M70 B50 (5012A)	B (NA)	12	84 x 75	4988	2	8,8	220-230	300-313	<b>37</b>
M73 B54 (54121)	B (NA)	12	85 x 79	5379	2	10	240	326	<b>69</b>
M73 B54 (54122)	B (NA)	12	85 x 79	5379	2	10	240-243	326-330	<b>69</b>
N13 B16 A	B (A)	4	77 x 85,8	1598	4	10,5	75-130	102-177	<b>5</b>
N20 B20	B (LA)	4	84 x 90,1	1997	4	11,0:1	135-180	184-245	<b>46</b>
N20 B20 A	AB (A)	4	84 x 90,1	1997	4	10	110-205	150-279	<b>57</b>
N20 B20 B	B (A)	4	84 x 90,1	1997	4	10-11	120-135	163-184	<b>46</b>
N20 B20 C	B (LA)	4	84 x 90,1	1997	4	11,0:1	135	184	<b>46</b>
N20 B20 D	B (A)	4	84 x 90,1	1997	4	10	135	184	<b>46</b>
N26 B20 A Euro 6	B (A)	4	84 x 90,1	1997	4	10	179-180	243-245	<b>49</b>
N40 B16 A	B (NA)	4	84 x 72	1596	4	10,2	77-85	105-115	<b>43</b>
N42 B18 A	B (NA)	4	84 x 81	1796	4	10,5	85	115	<b>42</b>
N42 B20 A	B (NA)	4	84 x 90	1995	4	10,5	100-110	136-150	<b>42</b>
N42 B20 B	B	4	84 x 90	1995	4	10,5:1	95	129	<b>42</b>
N42 B20 BZ	B	4	84 x 90	1995	4	9:1			<b>42</b>
N43 B16 A	B (NA)	4	82 x 75,7	1599	4	12	85-90	115-122	<b>23</b>
N43 B16 AA	B (NA)	4	82 x 75,7	1599	4	12	89-90	121-122	<b>23</b>
N43 B20 A	B (NA)	4	84 x 90	1995	4	12:1	90-125	122-170	<b>48</b>
N45 B16 A	B (NA)	4	84 x 72	1596	4	10,2	85	115	<b>44</b>
N45 B16 TU2	B (NA)	4	84 x 72	1596	4	10,2:1	85-90	115-122	<b>54</b>
N45 B16 TU2 OL	B	4	84 x 72	1596	4	10,25:1	85	116	<b>55</b>
N45 B20 A	B (NA)	4	85 x 88	1997	4	1	127	173	<b>72</b>
N46 B18 A	B (NA)	4	84 x 81	1796	4	10,25	85	115	<b>42</b>
N46 B20 A	B (NA)	4	84 x 90	1995	4	10,5	95-125	129-170	<b>42</b>
N46 B20 B	B (NA)	4	84 x 90	1995	4	10,5	95-125	129-170	<b>42</b>
N46 B20 BD	B (NA)	4	84 x 90	1995	4	10,5	95-125	129-170	<b>42</b>
N46 B20 C	B (NA)	4	84 x 90	1995	4	10,5	95-125	129-170	<b>45</b>
N46 B20 CC	B (NA)	4	84 x 90	1995	4	10,5	95-125	129-170	<b>42</b>
N46 B20 CD	B (NA)	4	84 x 90	1995	4	10,5	95-125	129-170	<b>42</b>
N46 B20 E	B (NA)	4	84 x 90	1995	4	10,5	95-125	129-170	<b>42</b>
N46 B20 LC	B	4	84 x 90	1995	4	9:1	105	143	<b>42</b>
N46 B20 TU2	B	4	84 x 90	1995	4	10,5:1	100-115	136-156	<b>42</b>
N46 B20 TU2 UL	B	4	84 x 90	1995	4	10,5:1	100	136	<b>45</b>
N47 D16 A Euro 5	D (A)	4	78 x 83,6	1598	4	16,5	70-85	95-116	<b>6</b>
N47 D20 A	D (A)	4	84 x 90	1995	4	17	66-145	90-197	<b>61</b>
N47 D20 B	D (A)	4	84 x 90	1995	4	16	150	204	<b>61</b>
N47 D20 C	D (A)	4	84 x 90	1995	4	16	66-150	90-204	<b>61</b>
N47 D20 D	D (A)	4	84 x 90	1995	4	16,5	150-160	204-218	<b>61</b>
N47 D20T0	D (LA)	4	84 x 90	1995	4	16:1	150	204	<b>62</b>
N47 D20UL	D (LA)	4	84 x 90	1995	4	16:1	105	143	<b>62</b>
N47S D20A	D (LA)	4	84 x 90	1995	4	16:1	150	204	<b>62</b>
N52 B25	B (NA)	6	82 x 78,8	2497	4	11	130-163	177-222	<b>22</b>
N52 B25 A	B (NA)	6	82 x 78,8	2497	4	11:1	130-160	177-218	<b>22</b>
N52 B25 AE	B (NA)	6	82 x 78,8	2497	4		130-140	177-190	<b>22</b>
N52 B25 AF	B (NA)	6	82 x 78,8	2497	4		150-160	204-218	<b>22</b>
N52 B25 B	B (NA)	6	82 x 78,8	2497	4		130-160	177-218	<b>22</b>
N52 B25 BE	B (NA)	6	82 x 78,8	2497	4	11:1	130-140	177-190	<b>22</b>
N52 B25 BF	B (NA)	6	82 x 78,8	2497	4	11:1	130-160	177-218	<b>22</b>
N52 B25 C	B	6	82 x 78,8	2497	4	11:1	160	218	<b>22</b>

		Cyl.	 mm	cm <sup>3</sup>		Comp. Ratio $\epsilon$	kW	PS	Pos
N52 B30 A	B (NA)	6	85 x 88	2996	4	10,7	155-200	211-272	71
N52 B30 AE	B (NA)	6	85 x 88	2996	4	10,7	179	243	71
N52 B30 AF	B (NA)	6	85 x 88	2996	4	10,7	179-200	243-272	71
N52 B30 B Euro 5	B (NA)	6	85 x 88	2996	4	12	160-200	218-272	71
N52 B30 BF	B (NA)	6	85 x 88	2996	4	10,7	160-200	218-272	71
N53 B25 A	B (NA)	6	82 x 78,8	2497	4	12:1	140	190	22
N53 B30	B	6	85 x 88	2996	4	12,0:1	160-200	218-272	74
N53 B30 A	B (NA)	6	85 x 88	2996	4	12	150-200	204-272	73
N54 B30 A	B (A)	6	84 x 89,6	2979	4	10,2	200-264	272-359	47
N54 B30 B	B (LA)	6	84 x 89,6	2979	4	10,2	225	306	47
N54 B30 T0	B (LA)	6	84 x 89,6	2979	4	10,2:1	240	326	47
N54 B30 U0	B (LA)	6	84 x 89,6	2979	4	10,2:1	225	306	47
N55 B30 A	B (A)	6	84 x 89,6	2979	4	10,2	200-272	272-370	46
N57 306 D2	D	6	84 x 90	2993	4		160	218	67
N57 D30 A	D (A)	6	84 x 90	2993	4	16,5	150-210	204-286	62
N57 D30 B	D (A)	6	84 x 90	2993	4	16,5	220-230	299-313	63
N57 D30 C	D (A)	6	84 x 90	2993	4	16,5	280	381	63
N57 D30 OL	D (LA)	6	84 x 90	2993	4	16,5:1	180-190	245-258	62
N57N 306 D2	D	6	84 x 90	2993	4		170	231	68
N57N 306 D3	D	6	84 x 90	2993	4		145-170	197-231	68
N57N 306 D5	D	6	84 x 90	2993	4		210	286	68
N62 B44 A	B (NA)	8	92 x 82,7	4398	4	10	235-245	320-333	88
N62 B48	B	8	93 x 88,3	4799	4	10,5:1	261-270	355-367	91
N62 B48 A	B (NA)	8	93 x 88,3	4799	4	10,5	261-270	355-367	91
N62 B48 B	B (NA)	8	93 x 88,3	4799	4	10,5	261-270	355-367	91
N63 B44 A	B (A)	8	89 x 88,3	4395	4	10	298-330	405-449	80
N63 B44 B	B (A)	8	89 x 88,3	4395	4	10	298-339	405-461	80
N63 B44 C	B (A)	8	89 x 88,3	4395	4	10	330-340	449-462	82
N63 B44 D	B (A)	8	89 x 88,3	4395	4	10	340-390	462-530	83
R 45	B	2	70 x 61,5	473	2	8,2:1	20	27	3
R 45 S	B	2	70 x 61,5	473	2	9,2:1	26	35	3
R 50	B	2	68 x 70,6	513	2	6,8/7,5	19	26	2
R 60	B	2	73,5 x 70,6	599	2	9:1	30	40	4
R 65	B	2	82 x 61,5	650	2	9,2:1	33	45	28
R 75	B	2	82 x 70,6	745	2	9:1	37	50	29
S14 B23 (234EA)	B (NA)	4	93,4 x 84	2302	4	9,6-11	143-162	195-220	93
S14 B23 (234S1)	B (NA)	4	93,4 x 84	2302	4	9,6-11	143-162	195-220	93
S14 B23 (234S2)	B (NA)	4	93,4 x 84	2303	4	9,6-11	143-162	195-220	93
S62 B50 (508S1)	B (NA)	8	94 x 89	4941	4	11	294	400	94
S63 B44 A	B (A)	8	89 x 88,3	4395	4	9,3	408-414	555-563	81
S70 B56 (56121)	B (NA)	12	86 x 80	5576	2	9,8	277-280	377-381	76

**B**



				Pos					Pos	
<b>B</b>	<b>1 (E81)</b>				120 i	03.2007 → 06.2011	N43 B20 A	B	48	
	116 d	11.2008 → 12.2011	N47 D20 A	D	61	120 i	03.2007 → 06.2011	N46 B20 A	B	42
	116 d	11.2008 → 12.2011	N47 D20 C	D	61	120 i	03.2007 → 06.2011	N46 B20 B	B	42
	116 d	01.2011 → 12.2011	N47 D20 A	D	61	120 i	03.2007 → 06.2011	N46 B20 BD	B	42
	116 d	01.2011 → 12.2011	N47 D20 C	D	61	120 i	03.2007 → 06.2011	N46 B20 C	B	45
	116 i	03.2007 → 12.2011	N43 B16 AA	B	23	120 i	03.2007 → 06.2011	N46 B20 CC	B	42
	116 i	09.2007 → 12.2011	N45 B16 A	B	44	123 d	03.2007 → 02.2009	N47 D20 B	D	61
	116 i	11.2008 → 12.2011	N43 B20 A	B	48	123 d	03.2009 → 06.2011	N47 D20 D	D	61
	118 d	09.2006 → 12.2011	N47 D20 A	D	61	130 i	09.2005 → 02.2007	N52 B30 A	B	71
	118 d	09.2006 → 12.2011	N47 D20 A	D	61	130 i	09.2005 → 02.2007	N52 B30 AF	B	71
	118 d	09.2006 → 12.2011	N47 D20 C	D	61	130 i	09.2005 → 02.2007	N52 B30 BF	B	71
	118 d	09.2006 → 12.2011	N47 D20 C	D	61	130 i	03.2007 → 06.2011	N52 B30 A	B	71
	118 d	09.2006 → 12.2011	N47 D20 C	D	61	130 i	03.2007 → 06.2011	N52 B30 AF	B	71
	118 i	09.2006 → 02.2008	N46 B20 B	B	42	130 i	03.2007 → 06.2011	N52 B30 B	B	71
	118 i	09.2006 → 12.2011	N43 B20 A	B	48	130 i	03.2007 → 06.2011	N52 B30 BF	B	71
	118 i	09.2006 → 12.2011	N46 B20 B	B	42	<b>1 (F20)</b>				
	120 d	03.2007 → 08.2008	N47 D20 A	D	61	114 d	11.2012 → 06.2015	N47 D16 A	D	6
	120 d	03.2007 → 12.2011	N47 D20 A	D	61	114 d	07.2015 → 06.2019	B37 D15 A	D	63
	120 d	03.2007 → 12.2011	N47 D20 A	D	61	114 i	07.2012 → 02.2015	N13 B16 A	B	5
	120 d	03.2007 → 12.2011	N47 D20 C	D	61	116 d	07.2011 → 02.2015	N47 D20 C	D	61
	120 d	03.2007 → 12.2011	N47 D20 C	D	61	116 d	03.2012 → 02.2015	N47 D16 A	D	6
	120 d	03.2007 → 12.2011	N47 D20 C	D	61	116 d	03.2015 → 06.2019	B37 D15 A	D	63
	120 d	09.2008 → 12.2011	N47 D20 C	D	61	116 i	07.2011 → 02.2015	N13 B16 A	B	5
	120 i	03.2007 → 12.2011	N43 B20 A	B	48	116 i	03.2015 → 06.2019	B38 B15 A	B	27
	120 i	03.2007 → 12.2011	N46 B20 B	B	42	118 d	07.2011 → 02.2015	N47 D20 C	D	61
	120 i	03.2007 → 12.2011	N46 B20 C	B	45	118 d	07.2011 → 02.2015	N47 D20 C	D	61
	120 i	03.2007 → 09.2012	N43 B20 A	B	48	118 d	03.2015 → 06.2019	B47 D20 A	D	63
	123 d	03.2007 → 12.2011	N47 D20 B	D	61	118 d	03.2015 → 06.2019	B47 D20 A	D	63
	123 d	03.2007 → 12.2011	N47 D20 D	D	61	118 d	03.2015 → 06.2019	B47 D20 A	D	63
	130 i	09.2006 → 12.2011	N52 B30 A	B	71	118 d xDrive	07.2013 → 02.2015	N47 D20 C	D	61
	130 i	09.2006 → 12.2011	N52 B30 A	B	71	118 d xDrive	03.2015 → 06.2019	B47 D20 A	D	63
	130 i	09.2006 → 12.2011	N52 B30 B	B	71	118 i	07.2011 → 02.2015	N13 B16 A	B	5
	130 i	09.2006 → 12.2011	N52 B30 B	B	71	118 i	03.2015 → 06.2015	N13 B16 A	B	5
	130 i	09.2006 → 12.2011	N52 B30 B	B	71	118 i	07.2015 → 06.2019	B38 B15 A	B	27
	130 i	09.2006 → 12.2011	N52 B30 BF	B	71	120 d	07.2011 → 02.2015	N47 D20 C	D	61
	130 i	09.2006 → 12.2011	N52 B30 BF	B	71	120 d	07.2011 → 02.2015	N47 D20 C	D	61
	<b>1 (E82)</b>				120 d	07.2011 → 06.2019	B47 D20 A	D	63	
	118i 2.0 16V	09.2007 →	N43 B20 A	B	48	120 d	07.2011 → 06.2019	N47 D20 C	D	61
	128i 3.0 24V (USA)	09.2007 →	N52 B30 A	B	71	120 d	03.2015 → 06.2019	B47 D20 A	D	63
	<b>1 (E87)</b>				120 d xDrive	11.2012 → 02.2015	N47 D20 C	D	61	
	116 d	03.2009 → 06.2011	N47 D20 A	D	61	120 d xDrive	11.2012 → 02.2015	N47 D20 C	D	61
	116 d	09.2010 → 06.2011	N47 D20 C	D	61	120 d xDrive	03.2015 → 06.2019	B47 D20 A	D	63
	116 d	01.2011 → 12.2011	N47 D20 C	D	61	120 i	03.2015 → 06.2016	N13 B16 A	B	5
	116 i	06.2004 → 06.2011	N45 B16 A	B	44	120 i	07.2016 → 06.2019	B48 B20 A	AB	31
	116 i	09.2007 → 06.2011	N43 B16 AA	B	23	120 i Active Flex	03.2015 → 06.2016	N20 B20 A	AB	57
	116 i	01.2009 → 06.2011	N43 B20 A	B	48	125 d	03.2012 → 02.2015	N47 D20 D	D	61
	118 d	06.2004 → 02.2007	M47 D20 (204D4)	D	59	125 d	03.2012 → 06.2019	B47 D20 B	D	64
	118 d	03.2007 → 06.2011	N47 D20 A	D	61	125 d	03.2012 → 06.2019	N47 D20 D	D	61
	118 d	03.2007 → 06.2011	N47 D20 A	D	61	125 d	03.2015 → 06.2019	B47 D20 B	D	64
	118 d	03.2007 → 06.2011	N47 D20 C	D	61	125 i	03.2012 → 11.2017	N20 B20 A	AB	57
	118 d	03.2007 → 06.2011	N47 D20 C	D	61	125 i	03.2012 → 11.2017	N20 B20 A	AB	57
	118 i	07.2004 → 02.2007	N46 B20 B	B	42	125 i	07.2016 → 06.2019	B48 B20 B	B	26
	118 i	09.2006 → 06.2011	N43 B20 A	B	48	125 i Active Flex	11.2014 → 11.2017	N20 B20 A	AB	57
	118 i	10.2006 → 06.2011	N46 B20 B	B	42	M 135 i	07.2012 → 02.2015	N55 B30 A	B	46
118 i	03.2007 → 12.2007	N43 B20 A	B	48	M 135 i	03.2015 → 06.2016	N55 B30 A	B	46	
118d 2.0 16V	09.2004 → 03.2007	M47 D20 TU2 UL	D	59	M 135 i xDrive	11.2012 → 02.2015	N55 B30 A	B	46	
118d 2.0 16V	09.2008 → 05.2011	M47 D20 TU2 UL	D	59	M 135 i xDrive	03.2015 → 06.2016	N55 B30 A	B	46	
118d 2.0 16V	09.2008 → 05.2011	N47 D20UL	D	62	M 140 i	07.2016 → 06.2019	B58 B30 A	B	26	
120 d	06.2004 → 02.2007	M47 D20 (204D4)	D	59	M 140 i xDrive	07.2016 → 06.2019	B58 B30 A	B	26	
120 d	06.2004 → 02.2007	M47 D20 (204D4)	D	59	<b>1 (F21)</b>					
120 d	05.2006 → 02.2007	M47 D20 (204D4)	D	59	114 d	07.2012 →	N47 D16 A	D	6	
120 d	03.2007 → 10.2010	N47 D20 A	D	61	114 d	06.2015 →	B37 D15 A	D	63	
120 d	03.2007 → 06.2011	N47 D20 A	D	61	114 i	12.2011 →	N13 B16 A	B	5	
120 d	03.2007 → 06.2011	N47 D20 A	D	61	116 d	12.2011 →	N47 D16 A	D	6	
120 d	03.2007 → 06.2011	N47 D20 C	D	61	116 d	01.2012 →	N47 D20 C	D	61	
120 i	06.2004 → 02.2007	N46 B20 B	B	42	116 d	03.2015 →	B37 D15 A	D	63	
120 i	06.2004 → 02.2007	N46 B20 BD	B	42	116 i	12.2011 →	N13 B16 A	B	5	
120 i	06.2004 → 02.2007	N46 B20 C	B	45	116 i	03.2015 →	B38 B15 A	B	27	
120 i	06.2004 → 02.2007	N46 B20 CC	B	42	118 d	12.2011 → 02.2015	N47 D20 C	D	61	
120 i	03.2007 → 06.2011	N43 B20 A	B	48	118 d	12.2011 →	N47 D20 C	D	61	

				Pos					Pos
118 d	03.2015 →	B47 D20 A	D	63	120 d	09.2007 → 10.2013	N47 D20 A	D	61
118 d xDrive	05.2013 →	N47 D20 C	D	61	120 d	09.2007 → 10.2013	N47 D20 A	D	61
118 d xDrive	03.2015 →	B47 D20 A	D	63	120 d	09.2007 → 10.2013	N47 D20 C	D	61
118 i	07.2012 →	N13 B16 A	B	5	120 d	09.2007 → 10.2013	N47 D20 C	D	61
118 i	03.2015 →	B38 B15 A	B	27	120 d	09.2007 → 10.2013	N47 D20 C	D	61
118 i	03.2015 →	N13 B16 A	B	5	120 i	10.2007 → 10.2013	N43 B20 A	B	48
120 d	01.2012 → 02.2015	N47 D20 C	D	61	120 i	09.2009 → 10.2013	N46 B20 B	B	42
120 d	07.2012 →	N47 D20 C	D	61	120 i	09.2009 → 10.2013	N46 B20 BD	B	42
120 d	07.2012 →	N47 D20 C	D	61	120 i	09.2009 → 10.2013	N46 B20 C	B	45
120 d	03.2015 →	B47 D20 A	D	63	120 i	09.2009 → 10.2013	N46 B20 E	B	42
120 d xDrive	01.2012 →	N47 D20 C	D	61	123 d	10.2007 → 10.2013	N47 D20 B	D	61
120 d xDrive	02.2012 → 02.2015	N47 D20 C	D	61	123 d	10.2007 → 10.2013	N47 D20 D	D	61
120 d xDrive	03.2015 →	B47 D20 A	D	63	125 i	03.2008 → 10.2013	N52 B30 A	B	71
120 i	03.2015 →	N13 B16 A	B	5	125 i	03.2008 → 10.2013	N52 B30 B	B	71
120 i	07.2016 →	B48 B20 A	AB	31	125 i	03.2008 → 10.2013	N52 B30 BF	B	71
125 d	12.2011 → 02.2015	N47 D20 D	D	61	128 i	10.2007 → 10.2013	N52 B30 A	B	71
125 d	12.2011 →	N47 D20 D	D	61	135 i	10.2007 → 10.2013	N54 B30 A	B	47
125 d	03.2015 →	B47 D20 B	D	64	135 i	10.2007 → 10.2013	N54 B30 A	B	47
125 i	12.2011 → 12.2019	N20 B20 A	AB	57	135 i	10.2007 → 10.2013	N55 B30 A	B	46
125 i	03.2013 →	N20 B20 A	AB	57	135 i	10.2007 → 10.2013	N55 B30 A	B	46
125 i	10.2015 →	B48 B20 B	B	26	M	03.2011 → 06.2012	N54 B30 A	B	47
125 i Active Flex	08.2014 →	N20 B20 A	AB	57	<b>1500 - 2002 (E6)</b>				
M 135 i	12.2011 →	N55 B30 A	B	46	2002 ti	06.1968 → 04.1972	M10 B20	B	77
M 135 i	03.2015 →	N55 B30 A	B	46	2002 tii (USA)	01.1972 → 12.1977	M10 B20	B	77
M 135 i xDrive	02.2012 →	N55 B30 A	B	46	<b>1500-2000 (115, 116, 118, 121)</b>				
M 135 i xDrive	03.2015 →	N55 B30 A	B	46	1500	09.1963 → 07.1966	M10 B16 (16A)	B	33
M 140 i	10.2015 →	B58 B30 A	B	26	1600	09.1963 → 12.1971	M10 B16 (16A)	B	33
M 140 i xDrive	09.2015 →	B58 B30 A	B	26	1600	04.1964 → 04.1968	M10 B16 (16A)	B	33
<b>1 (F40)</b>					1800	09.1965 → 12.1971	M10 B18	B	77
116 d	07.2019 →	B37 C15 A	D	63	1800	07.1969 → 09.1971	M10 B18	B	77
116 i	11.2020 →	B38 A15 A	B	25	2000	09.1965 → 11.1972	M10 B20	B	77
118 d	07.2019 →	B47 C20 B	D	64	2000	09.1968 → 07.1972	M10 B20	B	77
118 d	07.2019 →	B47 C20 B	D	64	2000	01.1970 → 11.1972	M10 B18	B	77
118 i	07.2019 →	B38 A15 A	B	25	2000 Ti	09.1967 → 12.1970	M10 B20	B	77
118 i	11.2020 →	B38 A15 A	B	25	2000 Ti / Tilux	01.1966 → 07.1972	M10 B20	B	77
120 d	03.2020 →	B47 C20 B	D	64	2000 Tii	05.1971 → 07.1972	M10 B20	B	77
120 d xDrive	07.2019 →	B47 C20 B	D	64	<b>1502-2002 (E10)</b>				
120 i	11.2020 →	B48 A20 A	AB	30	1502	01.1975 → 07.1977	M10 B16 (16A)	B	33
128 ti	11.2020 →	B48 A20 B	AB	30	1600 Ti	09.1967 → 11.1969	M10 B16 (16A)	B	33
<b>1 Convertible (E88)</b>					1802	09.1970 → 12.1971	M10 B18	B	77
118 d	09.2008 → 12.2013	N47 D20 A	D	61	1802	05.1971 → 07.1975	M10 B18	B	77
118 d	09.2008 → 12.2013	N47 D20 A	D	61	2002 (USA)	01.1972 → 12.1974	M10 B20	B	77
118 d	09.2008 → 12.2013	N47 D20 C	D	61	2002 Ti	09.1967 → 12.1971	M10 B20	B	77
118 d	09.2008 → 12.2013	N47 D20 C	D	61	2002 Ti	06.1968 → 04.1972	M10 B20	B	77
118 i	03.2008 → 12.2013	N43 B20 A	B	48	2002 tii	01.1971 → 07.1975	M10 B20	B	77
118 i	09.2008 → 12.2013	N46 B20 B	B	42	<b>1502-2002 Convertible (E10)</b>				
120 d	03.2008 → 12.2013	N47 D20 A	D	61	1600-2	12.1967 → 10.1971	M10 B16 (16A)	B	33
120 d	03.2008 → 12.2013	N47 D20 A	D	61	2002	05.1971 → 07.1975	M10 B20	B	77
120 d	03.2008 → 12.2013	N47 D20 C	D	61	<b>1502-2002 Touring (E6)</b>				
120 d	03.2008 → 12.2013	N47 D20 C	D	61	1600	05.1971 → 04.1973	M10 B16 (16A)	B	33
120 d	03.2008 → 12.2013	N47 D20 C	D	61	1802	05.1971 → 07.1975	M10 B18	B	77
120 i	12.2007 → 10.2013	N43 B20 A	B	48	2002	05.1971 → 07.1975	M10 B20	B	77
120 i	03.2008 → 12.2013	N43 B20 A	B	48	2002 Tii	05.1971 → 07.1975	M10 B20	B	77
120 i	03.2008 → 12.2013	N46 B20 B	B	42	<b>1600 GT Coupe</b>				
120 i	03.2008 → 12.2013	N46 B20 C	B	45	1.6	10.1967 → 05.1969	M10 B16 (16A)	B	33
120 i	03.2008 → 12.2013	N46 B20 E	B	42	<b>2 (F22)</b>				
123 d	09.2008 → 12.2013	N47 D20 B	D	61	228iX 2.0 16V	11.2013 →	N20 B20	B	46
123 d	09.2008 → 12.2013	N47 D20 D	D	61	228iX 2.0 16V	11.2013 →	N20 B20 A	AB	57
125 i	12.2007 → 10.2013	N52 B30 A	B	71	<b>2 (F23)</b>				
125 i	12.2007 → 10.2013	N52 B30 B	B	71	218d 2.0 16V	11.2013 →	N47 D20 C	D	61
125 i	12.2007 → 10.2013	N52 B30 BF	B	71	225d 2.0 16V	11.2013 →	N47 D20 D	D	61
128 i	12.2007 → 10.2013	N52 B30 A	B	71	228iX 2.0 16V	11.2013 →	N20 B20	B	46
135 i	03.2008 → 10.2013	N54 B30 A	B	47	228iX 2.0 16V	11.2013 →	N20 B20 A	AB	57
135 i	03.2008 → 10.2013	N55 B30 A	B	46	<b>2 Active Tourer (F45)</b>				
135 i	03.2008 → 12.2013	N55 B30 A	B	46	214 d	07.2014 → 02.2018	B37 C15 A	D	63
<b>1 Coupe (E82)</b>					216 d	03.2014 →	B37 C15 A	D	63
118 d	09.2009 → 10.2013	N47 D20 C	D	61	216 i	02.2015 → 02.2018	B38 A15 A	B	25
118 d	09.2009 → 10.2013	N47 D20 C	D	61	216 i	03.2018 →	B38 A15 A	B	25
120 d	09.2007 → 10.2013	N47 D20 A	D	61	218 d	11.2013 → 02.2018	B47 C20 A	D	63

			Pos				Pos			
<b>B</b>	218 d	11.2013 → 02.2018	B47 C20 A	D	63	228 i	07.2014 →	N20 B20 A	AB	57
	218 d	03.2018 →	B47 C20 B	D	64	228 i	07.2014 →	N26 B20 A	B	49
	218 d	03.2018 →	B47 C20 B	D	64	228 i xDrive	07.2014 →	N20 B20 A	AB	57
	218 d xDrive	12.2014 → 02.2018	B47 C20 A	D	63	228 i xDrive	07.2014 →	N26 B20 A	B	49
	218 d xDrive	12.2014 → 02.2018	B47 C20 A	D	63	230 i	07.2016 →	B48 B20 B	B	26
	218 d xDrive	03.2018 →	B47 C20 B	D	64	M 235 i	10.2013 →	N55 B30 A	B	46
	218 d xDrive	03.2018 →	B47 C20 B	D	64	M 235 i	03.2014 →	N55 B30 A	B	46
	218 i	07.2014 →	B38 A15 A	B	25	M 235 i xDrive	07.2014 →	N55 B30 A	B	46
	218 i	03.2018 →	B38 A15 A	B	25	M 240 i	09.2015 →	B58 B30 A	B	26
	220 d	03.2014 → 02.2018	B47 C20 A	D	63	M 240 i xDrive	09.2015 →	B58 B30 A	B	26
	220 d	03.2014 → 02.2018	B47 C20 A	D	63	M2	11.2015 → 06.2018	N55 B30 A	B	46
	220 d	03.2018 →	B47 C20 B	D	64	<b>2 Coupe (G42)</b>				
	220 d	03.2018 →	B47 C20 B	D	64	220 d Mild-Hybrid	08.2021 →	B47 D20 B	D	64
	220 d xDrive	03.2014 → 02.2018	B47 C20 A	D	63	220 i	08.2021 →	B48 B20 A	AB	31
	220 d xDrive	03.2014 → 02.2018	B47 C20 A	D	63	230 i	08.2021 →	B48 B20 B	B	26
	220 d xDrive	03.2018 →	B47 C20 B	D	64	<b>2 Gran Coupe (F44)</b>				
	220 d xDrive	03.2018 →	B47 C20 B	D	64	216 d	03.2020 →	B37 C15 A	D	63
	220 i	03.2014 →	B48 A20 A	AB	30	218 d	11.2019 →	B47 C20 B	D	64
	220 i	03.2014 →	B48 A20 A	AB	30	218 d	07.2020 →	B47 C20 B	D	64
	220 i	11.2020 →	B48 A20 A	AB	30	218 i	11.2019 →	B38 A15 A	B	25
	220 i Flex	01.2017 →	B48 A20 A	AB	30	218 i	11.2020 →	B38 A15 A	B	25
	220 i Flex	07.2017 →	B48 A20 B	AB	30	220 I XDRIVE	03.2021 →	B48 A20 A	AB	30
	225 i	11.2013 →	B48 A20 B	AB	30	220 d	11.2019 →	B47 C20 B	D	64
	225 i xDrive	03.2014 →	B48 A20 B	AB	30	220 d	11.2019 →	B47 C20 B	D	64
	225 xe Plug-in-Hybrid	11.2014 →	B38 A15 A	B	25	220 d xDrive	07.2020 →	B47 C20 B	D	64
	225 xe Plug-in-Hybrid	11.2014 →	B38 A15 A	B	25	220 i	07.2020 →	B48 A20 A	AB	30
	225 xe Plug-in-Hybrid	11.2020 →	B38 A15 A	B	25	220 i	11.2020 →	B48 A20 A	AB	30
	225 xe Plug-in-Hybrid	11.2020 →	B38 A15 A	B	25	228 i xDrive	11.2019 →	B46 A20 B	B	26
	<b>2 Convertible (F23)</b>					<b>2 Gran Tourer (F46)</b>				
	218 d	07.2015 →	B47 D20 A	D	63	214 d	07.2015 → 02.2018	B37 C15 A	D	63
	218 d	07.2015 →	B47 D20 A	D	63	216 d	08.2014 →	B37 C15 A	D	63
	218 i	03.2015 →	B38 B15 A	B	27	216 i	09.2014 → 02.2018	B38 A15 A	B	25
	220 d	03.2014 →	B47 D20 A	D	63	216 i	03.2018 →	B38 A15 A	B	25
	220 d	03.2014 →	B47 D20 A	D	63	218 d	07.2014 → 02.2018	B47 C20 A	D	63
	220 i	04.2014 → 07.2016	N20 B20 A	AB	57	218 d	07.2014 → 02.2018	B47 C20 A	D	63
	220 i	04.2014 → 07.2016	N20 B20 B	B	46	218 d	03.2018 →	B47 C20 B	D	64
	220 i	09.2015 →	B48 B20 A	AB	31	218 d	03.2018 →	B47 C20 B	D	64
	220 i	10.2017 →	B38 B15 A	B	27	218 d xDrive	03.2015 → 02.2018	B47 C20 A	D	63
	225 d	07.2015 →	B47 D20 B	D	64	218 d xDrive	03.2015 → 02.2018	B47 C20 A	D	63
	225 i	10.2017 →	B48 B20 A	AB	31	218 d xDrive	03.2018 →	B47 C20 B	D	64
	228 i	11.2014 →	N20 B20 A	AB	57	218 d xDrive	03.2018 →	B47 C20 B	D	64
	228 i xDrive	09.2015 →	N20 B20 A	AB	57	218 i	03.2015 → 02.2018	B38 A15 A	B	25
	230 i	07.2016 →	B48 B20 B	B	26	218 i	04.2017 →	B38 A15 A	B	25
	230 i xDrive	09.2016 →	B48 B20 B	B	26	220 d	09.2014 → 02.2018	B47 C20 A	D	63
	M 235 i	11.2014 →	N55 B30 A	B	46	220 d	09.2014 → 02.2018	B47 C20 A	D	63
M 235 i xDrive	07.2015 →	N55 B30 A	B	46	220 d	03.2018 →	B47 C20 B	D	64	
M 240 i	09.2015 →	B58 B30 A	B	26	220 d	03.2018 →	B47 C20 B	D	64	
M 240 i xDrive	09.2015 →	B58 B30 A	B	26	220 d xDrive	03.2015 → 02.2018	B47 C20 A	D	63	
<b>2 Coupe (F22, F87)</b>					<b>2000 - 3.0 (E9)</b>					
218 d	03.2014 → 06.2015	N47 D20 C	D	61	220 d xDrive	03.2015 → 02.2018	B47 C20 A	D	63	
218 d	03.2014 → 06.2015	N47 D20 C	D	61	220 d xDrive	03.2018 → 02.2018	B47 C20 B	D	64	
218 d	07.2015 → 06.2015	B47 D20 A	D	63	220 d xDrive	03.2018 → 02.2018	B47 C20 B	D	64	
218 d	07.2015 →	B47 D20 A	D	63	220 i	03.2015 → 02.2018	B48 A20 A	AB	30	
218 i	03.2015 →	B38 B15 A	B	27	220 i	03.2015 → 02.2018	B48 A20 A	AB	30	
220 d	10.2012 → 11.2014	N47 D20 C	D	61	220 i	11.2020 →	B48 A20 A	AB	30	
220 d	10.2012 → 11.2014	N47 D20 C	D	61	<b>2.5-3.2 Coupe (E9)</b>					
220 d	03.2014 →	B47 D20 A	D	63	2.5 CS	09.1974 → 03.1976	M30 B25	B	75	
220 d	11.2014 →	B47 D20 A	D	63	2800 CS	09.1967 → 12.1974	M30 B28	B	75	
220 d	11.2014 →	N47 D20 C	D	61	2800 CS	01.1969 → 04.1971	M30 B28	B	75	
220 d xDrive	06.2014 →	B47 D20 A	D	63	3.0 CS	09.1970 → 12.1974	M30 B30	B	78	
220 d xDrive	03.2015 →	B47 D20 A	D	63	3.0 CS	05.1971 → 03.1976	M30 B30	B	78	
220 i	10.2013 →	N20 B20 A	AB	57	3.0 CSi	07.1971 → 03.1976	M30 B30	B	78	
220 i	10.2013 →	N20 B20 B	B	46	3.0 CSiL	01.1974 → 11.1975	M30 B32 (315/1A)	B	78	
220 i	09.2015 →	B48 B20 A	AB	31	<b>2000 - 3.0 (E9)</b>					
220 i	10.2017 →	B38 B15 A	B	27	3.0 (S)	05.1971 → 08.1979	M30 B30 V	B	78	
225 d	01.2014 →	N47 D20 D	D	61	<b>2000 Coupe (120)</b>					
225 d	07.2015 →	B47 D20 B	D	64	C/CA	10.1965 → 06.1970	M10 B20	B	77	
225 i	10.2017 →	B48 B20 A	AB	31	CS	10.1965 → 12.1967	M10 B20	B	77	
228 i	01.2014 →	N20 B20 A	AB	57	CS	10.1965 → 06.1970	M10 B20	B	77	
<b>2500-3.3 (E3)</b>										

				Pos					Pos
2.8 BAVARIA	10.1968 → 12.1974	M30 B28	B	75	<b>3 (E46)</b>				
2.8 L	02.1975 → 04.1977	M30 B28	B	75	316 i	04.2000 → 02.2005	M43 B16 (164E3)	B	41
2500	10.1973 → 10.1976	M30 B25	B	75	316 i	02.2002 → 02.2005	N42 B18 A	B	42
2800	10.1968 → 07.1975	M30 B28	B	75	316 i	02.2002 → 02.2005	N46 B18 A	B	42
3.0	02.1975 → 04.1977	M30 B30 V	B	78	316 i	06.2002 → 02.2005	N40 B16 A	B	43
3.0 (S)	05.1971 → 08.1979	M30 B30 V	B	78	316 i	06.2002 → 02.2005	N45 B16 A	B	44
3.0 BAVARIA	09.1971 → 12.1974	M30 B30	B	78	316g 1.6i	11.1998 → 08.2001	M43 B16 (164E2)	BG	32
3.0 CSi	07.1971 → 03.1976	M30 B30	B	78	316g 1.6i	11.1998 → 08.2001	M43 B16 (164E3)	B	41
3.0 CSi	07.1971 → 03.1976	M30 B30 (306EA)	B	78	318 d	09.2001 → 03.2003	M47 D20 (204D1)	D	59
3.0 CSi	07.1971 → 03.1976	M30 B30 (306KA)	B	78	318 d	03.2003 → 02.2005	M47 D20 (204D4)	D	59
3.0 L	02.1975 → 04.1977	M30 B30	B	78	318 i	09.2001 → 03.2004	N42 B20 A	B	42
3.0 S	05.1971 → 04.1977	M30 B30	B	78	318 i	09.2001 → 02.2005	N42 B20 A	B	42
3.0 Si	07.1971 → 09.1975	M30 B30	B	78	318 i	03.2004 → 02.2005	N46 B20 A	B	42
3.0 Si	10.1975 → 04.1977	M30 B30	B	78	318 i	03.2004 → 02.2005	N46 B20 C	B	45
3.0i Bavaria (USA)	01.1975 → 1978	M30 B30	B	78	320 d	02.1998 → 08.2001	M47 D20 (204D1)	D	59
3.0i Bavaria (USA)	01.1975 → 1978	M30 B30 (306EA)	B	78	320 d	04.1998 → 09.2001	M47 D20 (204D1)	D	59
3.0i Bavaria (USA)	01.1975 → 1978	M30 B30 (306KA)	B	78	320 d	09.2001 → 05.2005	M47 D20 (204D4)	D	59
3.2 Li	10.1975 → 04.1977	M30 B32	B	78	320 i	03.1998 → 09.2000	M52 B20 (206S4)	B	10
3.3 Li (USA)	01.1977 → 08.1981	M30 B32 LU	B	78	320 i	09.2000 → 02.2005	M54 B22 (226S1)	B	11
<b>3 (E21)</b>					320 i	09.2000 → 02.2005	M54 B22 (226S1)	B	11
315	03.1981 → 03.1984	M10 B16 (164VB)	B	33	323 i	03.1998 → 09.2000	M52 B25 (256S4)	B	40
316	08.1975 → 08.1980	M10 B16 (164VA)	B	33	323 i	03.1998 → 09.2000	M52 B25 (256S4)	B	40
316	09.1980 → 12.1982	M10 B18 (184VC)	B	77	325 i	09.2000 → 02.2005	M54 B25 (256S5)	B	40
318	08.1975 → 08.1980	M10 B18 (184VA)	B	77	325 i	09.2000 → 04.2005	M54 B25 (256S5)	B	40
318 i	11.1979 → 08.1982	M10 B18 (184VA)	B	77	325 xi	09.2000 → 02.2005	M54 B25 (256S5)	B	40
320	06.1975 → 07.1979	M10 B20	B	77	325 xi	09.2000 → 04.2005	M54 B25 (256S5)	B	40
320 i	06.1975 → 08.1982	M10 B20	B	77	328 i	02.1998 → 06.2000	M52 B28 (286S2)	B	40
320 i	09.1976 → 12.1979	M10 B20	B	77	328 i	09.1998 → 12.2000	M52 B28 (286S2)	B	40
320 i	09.1979 → 12.1983	M10 B18 (184EA)	B	77	330 d	10.1999 → 02.2005	M57 D30 (306D1)	D	59
320i 2.0 (USA)	04.1977 → 12.1979	M10 B20	B	77	330 d	03.2003 → 02.2005	M57 D30 (306D2)	D	60
<b>3 (E30)</b>					330 i	06.2000 → 02.2005	M54 B30 (306S3)	B	40
315	09.1982 → 12.1991	M10 B16 (16A)	B	33	330 i	01.2001 → 04.2005	M54 B30 (306S3)	B	40
316	09.1983 → 06.1988	M10 B18 (184VD)	B	77	330 xd	01.2000 → 02.2003	M57 D30 (306D1)	D	59
316 (Ecotronic)	09.1983 → 06.1988	M10 B18 (184VD)	B	77	330 xd	09.2002 → 12.2004	M57 D30 (306D2)	D	60
316 i	08.1987 → 08.1988	M10 B18 (184KA)	B	77	330 xi	06.2000 → 02.2005	M54 B30 (306S3)	B	40
316 i	09.1987 → 06.1991	M40 B16 (164E1)	B	36	330 xi	09.2004 → 04.2005	M54 B30 (306S3)	B	40
316 i	07.1988 → 06.1991	M40 B16 (164E1)	B	36	330d 3.0 24V	04.2005 → 09.2005	M57 D30 TU	D	60
318 i	09.1982 → 09.1983	M10 B18 (184EA)	B	77	<b>3 (E90)</b>				
318 i	09.1982 → 08.1987	M10 B18 (184EB)	B	77	316 d	07.2009 → 12.2011	N47 D20 C	D	61
318 i	12.1984 → 08.1988	M10 B18 (184KA)	B	77	316 i	09.2005 → 10.2011	N45 B16 A	B	44
318 i	06.1987 → 12.1991	M40 B18 (184E1)	B	35	316 i	09.2007 → 10.2011	N43 B16 A	B	23
318 i	09.1987 → 06.1991	M40 B18 (184E1)	B	35	316 i	09.2007 → 10.2011	N43 B16 AA	B	23
318 is	09.1989 → 08.1991	M42 B18 (184S1)	B	38	318 d	03.2005 → 08.2007	M47 D20 (204D4)	D	59
320i 2.0 (AUS/CH/S)	09.1982 → 1987	M20 B20 L	B	8	318 d	02.2007 → 10.2011	N47 D20 A	D	61
324 d	09.1985 → 11.1988	M21 D24 (246DA)	D	14	318 d	02.2007 → 10.2011	N47 D20 C	D	61
324 td	09.1987 → 08.1991	M21 D24 (246TB)	D	14	318 d	09.2007 → 08.2008	N47 D20 A	D	61
M3 2.3	01.1986 → 12.1990	S14 B23 (234EA)	B	93	318 d	09.2008 → 10.2011	N47 D20 C	D	61
M3 2.3	01.1986 → 12.1990	S14 B23 (234S2)	B	93	318 i	09.2005 → 08.2007	N46 B20 B	B	42
M3 2.3	07.1986 → 06.1991	S14 B23 (234EA)	B	93	318 i	09.2007 → 10.2011	N43 B20 A	B	48
M3 2.3	07.1986 → 06.1991	S14 B23 (234S1)	B	93	318 i	09.2007 → 10.2011	N46 B20 B	B	42
M3 2.3	07.1986 → 06.1991	S14 B23 (234S2)	B	93	318 i	09.2007 → 10.2011	N46 B20 C	B	45
M3 2.3	02.1987 → 05.1989	S14 B23 (234EA)	B	93	318 i	09.2007 → 10.2011	N46 B20 CC	B	42
M3 2.3	02.1987 → 05.1989	S14 B23 (234S2)	B	93	318 i	09.2007 → 10.2011	N46 B20 CD	B	42
M3 EVO I 2.3	10.1988 → 10.1990	S14 B23 (234EA)	B	93	318 i	09.2007 → 10.2011	N46 B20 E	B	42
<b>3 (E36)</b>					320 d	12.2004 → 08.2007	M47 D20 (204D4)	D	59
316 i	03.1991 → 08.1993	M40 B16 (164E1)	B	36	320 d	12.2004 → 09.2007	M47 D20 (204D4)	D	59
316 i	09.1993 → 05.1998	M43 B16 (164E2)	BG	32	320 d	12.2004 → 09.2007	M47 D20 (204D4)	D	59
318 i	09.1990 → 08.1993	M40 B18 (184E1)	B	35	320 d	01.2007 → 12.2009	N47 D20 C	D	61
318 i	02.1992 → 12.1995	M42 B18 (184S1)	B	38	320 d	09.2007 → 08.2008	N47 D20 A	D	61
318 i	09.1993 → 11.1998	M43 B18 (184E2)	AB	56	320 d	09.2007 → 02.2010	N47 D20 A	D	61
318 is	09.1993 → 12.1995	M42 B18 (184S1)	B	38	320 d	09.2007 → 02.2010	N47 D20 C	D	61
318 is	01.1996 → 05.1998	M44 B19 (194S1)	B	70	320 d	09.2008 → 10.2011	N47 D20 C	D	61
318 tds	01.1995 → 02.1998	M41 D17 (174T1)	D	15	320 d	03.2010 → 10.2011	N47 D20 C	D	61
318g 1.8i	09.1993 → 04.1999	M43 B18 Gas	GF	58	320 d xDrive	09.2008 → 02.2010	N47 D20 A	D	61
320 i	01.1991 → 02.1998	M50 B20 (206S1)	B	9	320 d xDrive	09.2008 → 02.2010	N47 D20 C	D	61
320 i	01.1991 → 02.1998	M50 B20 (206S2)	B	9	320 d xDrive	09.2008 → 10.2011	N47 D20 C	D	61
320 i	01.1991 → 02.1998	M52 B20 (206S3)	B	10	320 d xDrive	03.2010 → 10.2011	N47 D20 C	D	61
323 i	05.1995 → 11.1998	M52 B25 (256S3)	B	40	320 i	12.2004 → 08.2007	N46 B20 B	B	42
328 i	01.1995 → 04.1998	M52 B28 (286S1)	B	40	320 i	12.2004 → 08.2007	N46 B20 BD	B	42

**B**



				Pos					Pos	
<b>B</b>	320 i	12.2004 → 08.2007	N46 B20 C	B	45	328i 3.0 24V	09.2007 → 12.2013	N52 B30 A	B	71
	320 i	02.2007 → 12.2011	N46 B20 B	B	42	<b>3 (F30, F80)</b>				
	320 i	02.2007 → 12.2011	N46 B20 C	B	45	316 d	03.2012 → 10.2018	B47 D20 A	D	63
	320 i	02.2007 → 12.2011	N46 B20 CC	B	42	316 d	03.2012 → 10.2018	N47 D20 C	D	61
	320 i	02.2007 → 12.2011	N46 B20 CD	B	42	316 i	07.2012 → 08.2016	N13 B16 A	B	5
	320 i	02.2007 → 12.2011	N46 B20 E	B	42	318 d	03.2012 → 06.2015	N47 D20 C	D	61
	320 i	03.2007 → 12.2011	N43 B20 A	B	48	318 d	03.2012 → 10.2018	B47 D20 A	D	63
	320 i	09.2007 → 10.2011	N43 B20 A	B	48	318 d	03.2012 → 10.2018	N47 D20 C	D	61
	320 si	09.2005 → 08.2006	N45 B20 A	B	72	318 d	07.2015 → 10.2018	B47 D20 A	D	63
	323 i	09.2005 → 02.2007	N52 B25 A	B	22	318 d xDrive	07.2013 → 06.2015	N47 D20 C	D	61
	323 i	09.2005 → 02.2007	N52 B25 B	B	22	318 d xDrive	07.2015 → 02.2018	B47 D20 A	D	63
	323 i	09.2005 → 02.2007	N52 B25 BE	B	22	318 i	07.2015 → 10.2018	B38 B15 A	B	27
	323 i	09.2005 → 02.2007	N52 B25 BF	B	22	320 d	11.2011 → 03.2016	N47 D20 C	D	61
	323 i	03.2007 → 12.2011	N52 B25 A	B	22	320 d	11.2011 → 03.2016	N47 D20 C	D	61
	323 i	03.2007 → 12.2011	N52 B25 BF	B	22	320 d	11.2011 → 10.2018	B47 D20 A	D	63
	325 d	09.2006 → 02.2010	M57 D30 (306D3)	D	60	320 d	11.2011 → 10.2018	N47 D20 C	D	61
	325 d	03.2010 → 10.2011	N57 D30 A	D	62	320 d	07.2015 → 10.2018	B47 D20 A	D	63
	325 i	12.2004 → 12.2011	N52 B25 A	B	22	320 d xDrive	08.2012 → 06.2015	N47 D20 C	D	61
	325 i	12.2004 → 12.2011	N52 B25 B	B	22	320 d xDrive	08.2012 → 06.2015	N47 D20 C	D	61
	325 i	12.2004 → 12.2011	N52 B25 BF	B	22	320 d xDrive	08.2012 → 10.2018	B47 D20 A	D	63
	325 i	01.2006 → 12.2011	N52 B25 A	B	22	320 d xDrive	08.2012 → 10.2018	N47 D20 C	D	61
	325 i	03.2007 → 12.2011	N53 B30 A	B	73	320 d xDrive	07.2015 → 10.2018	B47 D20 A	D	63
	325 i	03.2007 → 12.2011	N53 B30 A	B	73	320 i	03.2012 → 10.2018	N20 B20 A	AB	57
	325 i	09.2008 → 12.2009	N52 B25	B	22	320 i	03.2012 → 10.2018	N20 B20 A	AB	57
	325 i xDrive	09.2008 → 10.2011	N53 B30 A	B	73	320 i	03.2012 → 10.2018	N20 B20 B	B	46
	325 i xDrive	09.2008 → 10.2011	N53 B30 A	B	73	320 i	03.2012 → 10.2018	N20 B20 B	B	46
	325 xi	09.2005 → 08.2006	N52 B30 A	B	71	320 i	03.2012 → 10.2018	N20 B20 D	B	46
	325 xi	09.2005 → 08.2008	N52 B25 A	B	22	320 i	11.2012 → 06.2016	N13 B16 A	B	5
	325 xi	09.2007 → 08.2008	N53 B30 A	B	73	320 i	07.2015 → 10.2018	B48 B20 A	AB	31
	328 i xDrive	09.2008 → 12.2010	N52 B30 A	B	71	320 i ActiveFlex	12.2013 → 10.2018	N20 B20 A	AB	57
	328 xi	09.2006 → 12.2008	N52 B30 A	B	71	320 i xDrive	07.2012 → 10.2018	N20 B20 A	AB	57
	330 d	09.2005 → 09.2008	M57 D30 (306D3)	D	60	320 i xDrive	07.2012 → 10.2018	N20 B20 A	AB	57
	330 d	09.2005 → 12.2011	M57 D30 (306D3)	D	60	320 i xDrive	07.2012 → 10.2018	N20 B20 B	B	46
	330 d	09.2005 → 12.2011	N57 D30 A	D	62	320 i xDrive	07.2012 → 10.2018	N20 B20 B	B	46
	330 d	09.2008 → 10.2011	N57 D30 A	D	62	320 i xDrive	07.2015 → 10.2018	B48 B20 A	AB	31
	330 d xDrive	09.2008 → 10.2011	N57 D30 A	D	62	325 d	03.2013 → 02.2016	N47 D20 D	D	61
	330 i	12.2004 → 10.2011	N52 B30 A	B	71	325 d	03.2013 → 02.2016	N47 D20 D	D	61
	330 i	12.2004 → 10.2011	N52 B30 BF	B	71	325 d	03.2016 → 02.2018	B47 D20 B	D	64
	330 i	03.2007 → 12.2011	N52 B30 A	B	71	328 i	11.2011 → 10.2018	N20 B20 A	AB	57
	330 i	03.2007 → 12.2011	N52 B30 BF	B	71	328 i	03.2012 → 06.2016	N26 B20 A	B	49
	330 i	09.2007 → 10.2011	N53 B30 A	B	73	328 i ActiveFlex	02.2014 → 10.2018	N20 B20 A	AB	57
	330 i xDrive	09.2008 → 10.2011	N53 B30 A	B	73	328 i xDrive	07.2012 → 07.2016	N20 B20 A	AB	57
	330 xd	09.2005 → 08.2008	M57 D30 (306D3)	D	60	328 i xDrive	07.2012 → 07.2016	N26 B20 A	B	49
	330 xi	09.2005 → 08.2007	N52 B30 A	B	71	328 i xDrive	07.2012 → 08.2016	N20 B20 A	AB	57
	330 xi	09.2007 → 08.2008	N53 B30 A	B	73	328 i xDrive	07.2012 → 08.2016	N26 B20 A	B	49
	335 d	09.2006 → 12.2011	M57 D30 (306D5)	D	60	328i	11.2011 → 06.2015	N20 B20 A	AB	57
	335 d	09.2008 → 12.2011	M57 D30 (306D4)	D	60	330 d	07.2012 → 10.2018	N57 D30 A	D	62
	335 i	03.2006 → 12.2011	N54 B30 A	B	47	330 d	07.2012 → 10.2018	N57 D30 A	D	62
	335 i	03.2006 → 12.2011	N54 B30 A	B	47	330 d xDrive	03.2013 → 10.2018	N57 D30 A	D	62
	335 i	03.2006 → 12.2011	N54 B30 A	B	47	330 d xDrive	03.2013 → 10.2018	N57 D30 A	D	62
	335 i	03.2006 → 12.2011	N55 B30 A	B	46	330 e	11.2015 → 10.2018	B48 B20 A	AB	31
	335 i	03.2006 → 12.2011	N55 B30 A	B	46	330 e	11.2015 → 10.2018	B48 B20 A	AB	31
	335 i	09.2006 → 02.2010	N54 B30 A	B	47	330 i	07.2015 → 10.2018	B48 B20 B	B	26
	335 i	03.2010 → 12.2011	N55 B30 A	B	46	330 i xDrive	07.2015 → 10.2018	B48 B20 A	AB	31
	335 i xDrive	05.2008 → 10.2011	N54 B30 A	B	47	330 i xDrive	07.2015 → 10.2018	B48 B20 B	B	26
	335 i xDrive	05.2008 → 10.2011	N54 B30 A	B	47	335 d xDrive	07.2013 → 10.2018	N57 D30 B	D	63
	335 i xDrive	05.2008 → 10.2011	N55 B30 A	B	46	335 i	11.2011 → 06.2013	N55 B30 A	B	46
	335 i xDrive	09.2008 → 02.2010	N54 B30 A	B	47	335 i	11.2011 → 07.2015	N55 B30 A	B	46
	335 i xDrive	03.2010 → 10.2011	N55 B30 A	B	46	335 i	01.2013 → 12.2013	N55 B30 A	B	46
	335 xi	09.2006 → 06.2008	N54 B30 A	B	47	335 i	07.2013 → 07.2015	N55 B30 A	B	46
	335 xi	09.2006 → 06.2008	N54 B30 A	B	47	335 i xDrive	07.2012 → 06.2013	N55 B30 A	B	46
	335 xi	03.2007 → 08.2008	N54 B30 A	B	47	335 i xDrive	07.2012 → 07.2015	N55 B30 A	B	46
	335d 3.0 24V	09.2006 → 07.2008	M57 D30 N2	D	60	335 i xDrive	07.2013 → 07.2015	N55 B30 A	B	46
	<b>3 (E91)</b>					340 i	07.2015 → 10.2018	B58 B30 A	B	26
	328i 3.0 24V (USA)	09.2008 →	N52 B30 A	B	71	340 i	07.2015 → 10.2018	B58 B30 A	B	26
	<b>3 (E92)</b>					340 i xDrive	07.2015 → 10.2018	B58 B30 A	B	26
	335d 3.0 24V	09.2006 → 02.2010	M57 D30 N2	D	60	340 i xDrive	07.2015 → 10.2018	B58 B30 A	B	26
	<b>3 (E93)</b>					ActiveHybrid	07.2012 → 06.2015	N55 B30 A	B	46
	323i 2.5 24V	03.2007 → 12.2013	N52 B25 A	B	22	ActiveHybrid	07.2012 → 06.2015	N55 B30 A	B	46

				Pos					Pos
<b>3 (F31)</b>					320 td	09.2001 → 02.2005	M47 D20 (204D4)	D	<b>59</b>
320i 1.6 16V	05.2012 →	N13 B16 A	B	<b>5</b>	320 td	10.2001 → 12.2002	M47 D20 (204D4)	D	<b>59</b>
328d 2.0 16V	03.2013 →	N47 D20 C	D	<b>61</b>	325 ti	04.2001 → 12.2004	M54 B25 (256S5)	B	<b>40</b>
<b>3 (F35)</b>					<b>3 Convertible (E30)</b>				
328Li 2.0 16V	07.2012 →	N20 B20 A	AB	<b>57</b>	316 i Baur TC	09.1987 → 12.1989	M40 B16 (164E1)	B	<b>36</b>
328Li 2.0 16V	07.2012 →	N20 B20 C	B	<b>46</b>	318 Baur TC	09.1983 → 06.1988	M10 B18 (184VD)	B	<b>77</b>
<b>3 (G20, G80)</b>					318 i	09.1990 → 10.1993	M40 B18 (184E1)	B	<b>35</b>
316 d	03.2020 → 07.2020	B47 D20 B	D	<b>64</b>	318 i	10.1990 → 12.1992	M42 B18 (184S1)	B	<b>38</b>
316 d	11.2020 →	B47 D20 B	D	<b>64</b>	318 i Baur TC	09.1982 → 09.1983	M10 B18 (184EA)	B	<b>77</b>
316 d Mild-Hybrid	08.2020 →	B47 D20 B	D	<b>64</b>	318 i Baur TC	09.1983 → 06.1990	M10 B18 (184EB)	B	<b>77</b>
316 d Mild-Hybrid	11.2020 →	B47 D20 B	D	<b>64</b>	M3 2.3	06.1988 → 07.1989	S14 B23 (234EA)	B	<b>93</b>
318 d	03.2019 → 03.2020	B47 D20 B	D	<b>64</b>	M3 2.3	06.1988 → 06.1991	S14 B23 (234EA)	B	<b>93</b>
318 d	03.2019 → 03.2020	B47 D20 B	D	<b>64</b>	M3 2.3	06.1988 → 10.1993	S14 B23 (234S2)	B	<b>93</b>
318 d Mild-Hybrid	04.2020 →	B47 D20 B	D	<b>64</b>	<b>3 Convertible (E36)</b>				
318 d Mild-Hybrid	04.2020 →	B47 D20 B	D	<b>64</b>	318 i	01.1994 → 12.1995	M42 B18 (184S1)	B	<b>38</b>
318 i	03.2020 →	B48 B20 A	AB	<b>31</b>	318 i	03.1994 → 11.1999	M43 B18 (184E2)	AB	<b>56</b>
320 d	11.2018 → 02.2020	B47 D20 B	D	<b>64</b>	318 is	01.1996 → 09.1999	M44 B19 (194S1)	B	<b>70</b>
320 d	11.2018 → 02.2020	B47 D20 B	D	<b>64</b>	320 i	12.1993 → 11.1999	M50 B20 (206S2)	B	<b>9</b>
320 d Mild-Hybrid	03.2020 →	B47 D20 B	D	<b>64</b>	320 i	12.1993 → 11.1999	M52 B20 (206S3)	B	<b>10</b>
320 d Mild-Hybrid	03.2020 →	B47 D20 B	D	<b>64</b>	323 i	05.1995 → 11.1999	M52 B25 (256S3)	B	<b>40</b>
320 d Mild-Hybrid	03.2020 →	B47 D20 B	D	<b>64</b>	328 i	01.1995 → 11.1999	M52 B28 (286S1)	B	<b>40</b>
xDrive					<b>3 Convertible (E46)</b>				
320 d Mild-Hybrid	03.2020 →	B47 D20 B	D	<b>64</b>	318 Ci	12.2000 → 08.2006	N42 B20 A	B	<b>42</b>
xDrive					318 Ci	12.2000 → 08.2006	N46 B20 A	B	<b>42</b>
320 d xDrive	11.2018 → 02.2020	B47 D20 B	D	<b>64</b>	318 Ci	09.2001 → 12.2007	N42 B20 A	B	<b>42</b>
320 d xDrive	11.2018 → 02.2020	B47 D20 B	D	<b>64</b>	318 Ci	09.2001 → 12.2007	N46 B20 A	B	<b>42</b>
320 e Plug-in-Hybrid	07.2020 →	B48 B20 A	AB	<b>31</b>	318 Ci	03.2004 → 08.2006	N46 B20 A	B	<b>42</b>
320 e Plug-in-Hybrid	07.2020 →	B48 B20 A	AB	<b>31</b>	318 Ci	03.2004 → 08.2006	N46 B20 C	B	<b>45</b>
320 i	03.2019 →	B48 B20 A	AB	<b>31</b>	320 Cd	02.2005 → 12.2007	M47 D20 (204D4)	D	<b>59</b>
320 i	06.2019 →	B48 B20 B	B	<b>26</b>	320 Ci	09.2000 → 12.2007	M54 B22 (226S1)	B	<b>11</b>
320 i xDrive	07.2019 →	B48 B20 A	AB	<b>31</b>	320 Ci	01.2006 → 12.2007	M54 B22 (226S1)	B	<b>11</b>
330 d	03.2019 →	B57 D30 A	D	<b>63</b>	323 Ci	04.2000 → 09.2000	M52 B25 (256S4)	B	<b>40</b>
330 d Mild-Hybrid	11.2020 →	B57 D30 B	D	<b>62</b>	323 Ci	04.2000 → 09.2000	M52 B25 (256S4)	B	<b>40</b>
330 d Mild-Hybrid	11.2020 →	B57 D30 B	D	<b>62</b>	325 Ci	09.2000 → 08.2006	M54 B25 (256S5)	B	<b>40</b>
xDrive					325 Ci	09.2000 → 12.2006	M54 B25 (256S5)	B	<b>40</b>
330 d xDrive	07.2019 →	B57 D30 A	D	<b>63</b>	330 Cd	08.2005 → 12.2007	M57 D30 (306D2)	D	<b>60</b>
330 e Plug-in-Hybrid	07.2019 → 02.2020	B48 B20 A	AB	<b>31</b>	330 Ci	06.2000 → 08.2006	M54 B30 (306S3)	B	<b>40</b>
330 e Plug-in-Hybrid	07.2019 → 02.2020	B48 B20 B	B	<b>26</b>	330 Ci	06.2000 → 12.2006	M54 B30 (306S3)	B	<b>40</b>
330 e Plug-in-Hybrid	07.2019 →	B48 B20 A	AB	<b>31</b>	<b>3 Convertible (E93)</b>				
330 e Plug-in-Hybrid	07.2019 →	B48 B20 B	B	<b>26</b>	318 i	03.2010 → 12.2013	N43 B20 A	B	<b>48</b>
330 e Plug-in-Hybrid	03.2020 →	B48 B20 B	B	<b>26</b>	320 d	09.2007 → 02.2010	N47 D20 A	D	<b>61</b>
330 e Plug-in-Hybrid	07.2020 →	B48 B20 A	AB	<b>31</b>	320 d	09.2007 → 02.2010	N47 D20 C	D	<b>61</b>
xDrive					320 d	01.2008 → 12.2013	N47 D20 C	D	<b>61</b>
330 e Plug-in-Hybrid	07.2020 →	B48 B20 A	AB	<b>31</b>	320 d	03.2008 → 02.2010	N47 D20 A	D	<b>61</b>
xDrive					320 d	03.2008 → 02.2010	N47 D20 C	D	<b>61</b>
330 i	11.2018 →	B48 B20 B	B	<b>26</b>	320 d	03.2010 → 10.2013	N47 D20 C	D	<b>61</b>
330 i xDrive	11.2018 →	B48 B20 B	B	<b>26</b>	320 d	03.2010 → 10.2013	N47 D20 C	D	<b>61</b>
M340 d Mild-Hybrid	04.2020 →	B57 D30 B	D	<b>62</b>	320 i	09.2006 → 10.2013	N43 B20 A	B	<b>48</b>
xDrive					320 i	01.2007 → 08.2013	N46 B20 B	B	<b>42</b>
<b>3 (G28)</b>					320 i	03.2007 → 10.2013	N43 B20 A	B	<b>48</b>
330 Li	02.2021 →	B48 B20 B	B	<b>26</b>	323 i	03.2007 → 09.2011	N52 B25 A	B	<b>22</b>
<b>3 Compact (E36)</b>					323 i	03.2007 → 09.2011	N52 B25 A	B	<b>22</b>
316 g	02.1996 → 08.2000	M43 B16 (164E2)	BG	<b>32</b>	325 d	03.2007 → 12.2010	M57 D30 (306D3)	D	<b>60</b>
316 i	01.1994 → 08.2000	M43 B16 (164E2)	BG	<b>32</b>	325 d	03.2007 → 12.2010	M57 D30 (306D3)	D	<b>60</b>
318 tds	06.1995 → 08.2000	M41 D17 (174T1)	D	<b>15</b>	325 d	09.2009 → 09.2013	N57 D30 A	D	<b>62</b>
318 ti	09.1994 → 12.1995	M42 B18 (184S1)	B	<b>38</b>	325 i	10.2006 → 12.2013	N53 B30 A	B	<b>73</b>
318 ti	01.1996 → 08.1999	M44 B19 (194S1)	B	<b>70</b>	325 i	12.2006 → 02.2010	N52 B25 A	B	<b>22</b>
323 ti	09.1997 → 08.2000	M52 B25 (256S3)	B	<b>40</b>	325 i	03.2007 → 12.2013	N53 B30 A	B	<b>73</b>
323 ti	01.1999 → 08.2000	M52 B25 (256S3)	B	<b>40</b>	325 i	03.2010 → 10.2013	N52 B25 A	B	<b>22</b>
<b>3 Compact (E46)</b>					330 d	03.2007 → 12.2013	M57 D30 (306D3)	D	<b>60</b>
316 ti	06.2001 → 02.2005	N42 B18 A	B	<b>42</b>	330 d	01.2009 → 12.2013	N57 D30 A	D	<b>62</b>
316 ti	06.2001 → 02.2005	N46 B18 A	B	<b>42</b>	330 i	03.2007 → 02.2010	N52 B30 A	B	<b>71</b>
316 ti	06.2002 → 02.2005	N40 B16 A	B	<b>43</b>	330 i	03.2007 → 10.2013	N53 B30 A	B	<b>73</b>
316 ti	06.2002 → 02.2005	N40 B16 A	B	<b>43</b>	330 i	03.2010 → 10.2013	N52 B30 A	B	<b>71</b>
316 ti	06.2002 → 02.2005	N45 B16 A	B	<b>44</b>	330 i	03.2010 → 10.2013	N52 B30 AF	B	<b>71</b>
318 td	03.2003 → 02.2005	M47 D20 (204D4)	D	<b>59</b>	335 i	05.2006 → 10.2013	N54 B30 A	B	<b>47</b>
318 ti	03.2001 → 12.2004	N42 B20 A	B	<b>42</b>	335 i	05.2006 → 10.2013	N55 B30 A	B	<b>46</b>
318 ti	03.2001 → 12.2004	N42 B20 A	B	<b>42</b>	335 i	12.2006 → 02.2010	N54 B30 A	B	<b>47</b>
318 ti	03.2001 → 12.2004	N46 B20 A	B	<b>42</b>	335 i	01.2007 → 10.2013	N54 B30 A	B	<b>47</b>
318 ti	03.2001 → 12.2004	N46 B20 A	B	<b>42</b>					

**B**

				Pos					Pos	
<b>B</b>	335 i	03.2010 → 10.2013	N55 B30 A	B	<b>46</b>	325 i	03.2010 → 06.2013	N53 B30 A	B	<b>73</b>
<b>3 Coupe (E36)</b>										
	316 i	09.1993 → 11.1998	M43 B16 (164E2)	BG	<b>32</b>	325 i	03.2010 → 10.2013	N52 B25 A	B	<b>22</b>
	318 i	03.1992 → 06.1994	M40 B18 (184E1)	B	<b>35</b>	325 i	03.2010 → 10.2013	N52 B25 AF	B	<b>22</b>
	318 is	01.1992 → 12.1995	M42 B18 (184S1)	B	<b>38</b>	325 i	03.2010 → 10.2013	N52 B25 BF	B	<b>22</b>
	318 is	09.1995 → 04.1999	M44 B19 (194S1)	B	<b>70</b>	325 i xDrive	09.2008 → 06.2013	N53 B30 A	B	<b>73</b>
	320 i	12.1991 → 11.1998	M50 B20 (206S1)	B	<b>9</b>	325 i xDrive	09.2008 → 12.2013	N53 B30 A	B	<b>73</b>
	320 i	12.1991 → 11.1998	M50 B20 (206S2)	B	<b>9</b>	325 i xDrive	03.2010 → 04.2013	N52 B25 A	B	<b>22</b>
	320 i	12.1991 → 11.1998	M52 B20 (206S3)	B	<b>10</b>	325 i xDrive	03.2010 → 04.2013	N52 B25 AF	B	<b>22</b>
	323 i	05.1995 → 04.1999	M52 B25 (256S3)	B	<b>40</b>	325 xi	09.2006 → 02.2010	N52 B25 A	B	<b>22</b>
	328 i	01.1995 → 04.1999	M52 B28 (286S1)	B	<b>40</b>	325 xi	09.2007 → 08.2008	N53 B30 A	B	<b>73</b>
						325 xi	09.2007 → 08.2008	N53 B30 A	B	<b>73</b>
<b>3 Coupe (E46)</b>										
	316 Ci	04.2000 → 07.2006	M43 B16 (164E3)	B	<b>41</b>	328 i	06.2006 → 06.2013	N52 B30 A	B	<b>71</b>
	316 Ci	06.2002 → 07.2006	N45 B16 A	B	<b>44</b>	328 i xDrive	09.2008 → 06.2013	N52 B30 A	B	<b>71</b>
	318 Ci	12.2000 → 05.2006	N42 B20 A	B	<b>42</b>	328 xi	09.2006 → 08.2008	N52 B30 A	B	<b>71</b>
	318 Ci	12.2000 → 05.2006	N46 B20 A	B	<b>42</b>	330 d	03.2006 → 08.2008	M57 D30 (306D3)	D	<b>60</b>
	318 Ci	09.2001 → 02.2004	N42 B20 A	B	<b>42</b>	330 d	01.2009 → 12.2013	N57 D30 A	D	<b>62</b>
	318 Ci	03.2004 → 05.2006	N46 B20 A	B	<b>42</b>	330 d xDrive	02.2010 → 06.2013	N57 D30 A	D	<b>62</b>
	318 Ci	03.2004 → 05.2006	N46 B20 A	B	<b>42</b>	330 i	09.2006 → 02.2010	N52 B30 A	B	<b>71</b>
	318 Ci	03.2004 → 05.2006	N46 B20 C	B	<b>45</b>	330 i	09.2006 → 02.2010	N52 B30 AF	B	<b>71</b>
	320 Cd	11.2003 → 07.2006	M47 D20 (204D4)	D	<b>59</b>	330 i	09.2006 → 02.2010	N52 B30 BF	B	<b>71</b>
	320 Ci	02.1999 → 08.2001	M52 B20 (206S4)	B	<b>10</b>	330 i	09.2007 → 06.2013	N53 B30 A	B	<b>73</b>
	320 Ci	01.2000 → 05.2006	M54 B22 (226S1)	B	<b>11</b>	330 i	03.2010 → 06.2013	N52 B30 A	B	<b>71</b>
	320 Ci	01.2000 → 05.2006	M54 B22 (226S1)	B	<b>11</b>	330 i xDrive	03.2010 → 06.2013	N53 B30 A	B	<b>73</b>
	323 Ci	04.1999 → 09.2000	M52 B25 (256S4)	B	<b>40</b>	330 xd	03.2006 → 08.2008	M57 D30 (306D3)	D	<b>60</b>
	323 Ci	04.1999 → 09.2000	M52 B25 (256S4)	B	<b>40</b>	330 xd	03.2008 → 02.2010	N57 D30 A	D	<b>62</b>
	323 i	04.1999 → 12.2000	M52 B25 (256S4)	B	<b>40</b>	330 xi	09.2006 → 08.2007	N52 B30 A	B	<b>71</b>
	325 Ci	09.2000 → 05.2006	M54 B25 (256S5)	B	<b>40</b>	330 xi	09.2006 → 08.2007	N52 B30 A	B	<b>71</b>
	325 Ci	09.2000 → 07.2006	M54 B25 (256S5)	B	<b>40</b>	330 xi	03.2007 → 02.2010	N53 B30 A	B	<b>73</b>
	328 Ci	12.1998 → 05.2000	M52 B28 (286S2)	B	<b>40</b>	335 d	03.2006 → 03.2013	M57 D30 (306D5)	D	<b>60</b>
	330 Cd	03.2003 → 07.2006	M57 D30 (306D2)	D	<b>60</b>	335 i	06.2006 → 06.2013	N54 B30 A	B	<b>47</b>
	330 Ci	06.2000 → 05.2006	M54 B30 (306S3)	B	<b>40</b>	335 i	06.2006 → 06.2013	N54 B30 A	B	<b>47</b>
	330 Ci	06.2000 → 07.2006	M54 B30 (306S3)	B	<b>40</b>	335 i	06.2006 → 06.2013	N55 B30 A	B	<b>46</b>
	330 xi	06.2000 → 07.2006	M54 B30 (306S3)	B	<b>40</b>	335 i	06.2006 → 06.2013	N55 B30 A	B	<b>46</b>
<b>3 Coupe (E92)</b>										
	316 i	09.2007 → 06.2013	N43 B16 AA	B	<b>23</b>	335 i	03.2007 → 06.2013	N54 B30 A	B	<b>47</b>
	318 i	03.2010 → 12.2013	N43 B20 A	B	<b>48</b>	335 i xDrive	11.2008 → 06.2013	N55 B30 A	B	<b>46</b>
	320 d	09.2006 → 02.2010	N47 D20 A	D	<b>61</b>	335 i xDrive	11.2008 → 12.2013	N54 B30 A	B	<b>47</b>
	320 d	09.2006 → 02.2010	N47 D20 A	D	<b>61</b>	335 i xDrive	11.2008 → 12.2013	N55 B30 A	B	<b>46</b>
	320 d	09.2006 → 02.2010	N47 D20 C	D	<b>61</b>	335 i xDrive	01.2009 → 06.2013	N54 B30 A	B	<b>47</b>
	320 d	03.2007 → 06.2013	N47 D20 A	D	<b>61</b>	335 xi	03.2007 → 02.2010	N54 B30 A	B	<b>47</b>
	320 d	03.2007 → 06.2013	N47 D20 C	D	<b>61</b>	335 xi	03.2007 → 02.2010	N54 B30 A	B	<b>47</b>
	320 d	09.2008 → 02.2010	N47 D20 C	D	<b>61</b>	335 xi	03.2007 → 02.2010	N55 B30 A	B	<b>46</b>
	320 d	03.2010 → 06.2013	N47 D20 C	D	<b>61</b>	<b>3 Gran Turismo (F34)</b>				
	320 d	03.2010 → 06.2013	N47 D20 C	D	<b>61</b>	318 d	03.2013 → 06.2015	N47 D20 C	D	<b>61</b>
	320 d	03.2010 → 06.2013	N47 D20 C	D	<b>61</b>	318 d	03.2013 → 06.2015	N47 D20 C	D	<b>61</b>
	320 d xDrive	09.2008 → 02.2010	N47 D20 C	D	<b>61</b>	318 d	07.2015 → 06.2015	B47 D20 A	D	<b>63</b>
	320 d xDrive	09.2008 → 02.2010	N47 D20 C	D	<b>61</b>	318 d	07.2015 →	B47 D20 A	D	<b>63</b>
	320 d xDrive	09.2008 → 06.2013	N47 D20 C	D	<b>61</b>	320 d	03.2013 → 06.2015	N47 D20 C	D	<b>61</b>
	320 d xDrive	03.2010 → 06.2013	N47 D20 C	D	<b>61</b>	320 d	03.2013 → 06.2015	N47 D20 C	D	<b>61</b>
	320 d xDrive	03.2010 → 06.2013	N47 D20 C	D	<b>61</b>	320 d	03.2013 → 06.2015	N47 D20 C	D	<b>61</b>
	320 i	01.2007 → 12.2013	N43 B20 A	B	<b>48</b>	320 d	07.2015 → 06.2015	B47 D20 A	D	<b>63</b>
	320 i	03.2007 → 12.2013	N43 B20 A	B	<b>48</b>	320 d	07.2015 →	B47 D20 A	D	<b>63</b>
	320 i	06.2007 → 12.2013	N46 B20 B	B	<b>42</b>	320 d xDrive	07.2013 → 06.2015	N47 D20 C	D	<b>61</b>
	320 i	01.2010 → 12.2013	N46 B20 B	B	<b>42</b>	320 d xDrive	07.2013 → 06.2015	N47 D20 C	D	<b>61</b>
	320 i	01.2010 → 12.2013	N46 B20 CC	B	<b>42</b>	320 d xDrive	07.2013 → 06.2015	N47 D20 C	D	<b>61</b>
	320 i	01.2010 → 12.2013	N46 B20 CD	B	<b>42</b>	320 d xDrive	07.2015 → 06.2015	B47 D20 A	D	<b>63</b>
	320 i	01.2010 → 12.2013	N46 B20 E	B	<b>42</b>	320 d xDrive	07.2015 →	B47 D20 A	D	<b>63</b>
	323 i	04.2006 → 02.2012	N52 B25 AE	B	<b>22</b>	320 i	03.2013 → 06.2016	N20 B20 A	AB	<b>57</b>
	323 i	04.2006 → 02.2012	N52 B25 BE	B	<b>22</b>	320 i	03.2013 → 06.2016	N20 B20 A	AB	<b>57</b>
	323 i	06.2006 → 08.2008	N52 B25 A	B	<b>22</b>	320 i	03.2013 → 06.2016	N20 B20 B	B	<b>46</b>
	325 d	02.2007 → 02.2010	M57 D30 (306D3)	D	<b>60</b>	320 i	03.2013 → 06.2016	N20 B20 B	B	<b>46</b>
	325 d	02.2007 → 02.2010	M57 D30 (306D3)	D	<b>60</b>	320 i	07.2016 →	B48 B20 A	AB	<b>31</b>
	325 d	09.2009 → 12.2013	N57 D30 A	D	<b>62</b>	320 i	07.2016 →	B48 B20 A	AB	<b>31</b>
	325 i	06.2006 → 02.2010	N52 B25 A	B	<b>22</b>	320 i xDrive	11.2012 → 06.2016	N20 B20 A	AB	<b>57</b>
	325 i	06.2006 → 02.2010	N52 B25 AF	B	<b>22</b>	320 i xDrive	11.2012 → 06.2016	N20 B20 B	B	<b>46</b>
	325 i	06.2006 → 02.2010	N52 B25 BF	B	<b>22</b>	320 i xDrive	07.2013 → 06.2016	N20 B20 A	AB	<b>57</b>
	325 i	09.2007 → 06.2013	N53 B30 A	B	<b>73</b>	320 i xDrive	07.2013 → 06.2016	N20 B20 B	B	<b>46</b>
	325 i	03.2010 → 06.2013	N52 B25 A	B	<b>22</b>	320 i xDrive	07.2013 → 06.2016	N20 B20 B	B	<b>46</b>
	325 i	03.2010 → 06.2013	N52 B25 AF	B	<b>22</b>	320 i xDrive	07.2016 →	B48 B20 A	AB	<b>31</b>
	325 i	03.2010 → 06.2013	N52 B25 AF	B	<b>22</b>	320 i xDrive	07.2016 →	B48 B20 A	AB	<b>31</b>
	325 i	03.2010 → 06.2013	N52 B25 BF	B	<b>22</b>	325 d	07.2013 → 06.2016	N47 D20 D	D	<b>61</b>



			Pos				Pos		
325 d	07.2013 → 06.2016	N47 D20 D	D	61	318 d	09.2008 → 06.2012	N47 D20 C	D	61
325 d	07.2016 → 02.2018	B47 D20 B	D	64	318 i	01.2006 → 08.2007	N46 B20 B	B	42
328 i	03.2013 → 06.2016	N20 B20 A	AB	57	318 i	05.2007 → 05.2012	N43 B20 A	B	48
328 i	07.2014 → 06.2015	N26 B20 A	B	49	318 i	09.2007 → 03.2012	N46 B20 B	B	42
328 i xDrive	07.2013 → 06.2016	N20 B20 A	AB	57	320 d	12.2004 → 08.2007	M47 D20 (204D4)	D	59
328 i xDrive	07.2014 → 06.2016	N26 B20 A	B	49	320 d	06.2005 → 08.2007	M47 D20 (204D4)	D	59
330 d	03.2014 →	N57 D30 A	D	62	320 d	02.2007 → 02.2010	N47 D20 A	D	61
330 d	03.2014 →	N57 D30 A	D	62	320 d	02.2007 → 02.2010	N47 D20 C	D	61
330 d xDrive	03.2014 →	N57 D30 A	D	62	320 d	02.2007 → 12.2010	N47 D20 A	D	61
330 d xDrive	03.2014 →	N57 D30 A	D	62	320 d	02.2007 → 12.2010	N47 D20 C	D	61
330 i	07.2016 →	B48 B20 B	B	26	320 d	09.2007 → 02.2010	N47 D20 A	D	61
330 i xDrive	07.2016 →	B48 B20 B	B	26	320 d	09.2008 → 06.2012	N47 D20 C	D	61
330 i xDrive	07.2016 →	B48 B20 B	B	26	320 d	03.2010 → 05.2012	N47 D20 C	D	61
335 d xDrive	03.2014 →	N57 D30 B	D	63	320 d	03.2010 → 05.2012	N47 D20 C	D	61
335 i	03.2013 → 03.2014	N55 B30 A	B	46	320 d xDrive	02.2008 → 02.2010	N47 D20 C	D	61
335 i	03.2013 → 06.2016	N55 B30 A	B	46	320 d xDrive	09.2008 → 02.2010	N47 D20 C	D	61
335 i	04.2014 → 06.2016	N55 B30 A	B	46	320 d xDrive	07.2009 → 06.2012	N47 D20 C	D	61
335 i xDrive	03.2013 → 03.2014	N55 B30 A	B	46	320 d xDrive	03.2010 → 05.2012	N47 D20 C	D	61
335 i xDrive	07.2013 → 06.2016	N55 B30 A	B	46	320 d xDrive	03.2010 → 06.2012	N47 D20 C	D	61
335 i xDrive	04.2014 → 06.2016	N55 B30 A	B	46	320 i	09.2005 → 06.2012	N46 B20 B	B	42
340 i	07.2016 →	B58 B30 A	B	26	320 i	09.2005 → 06.2012	N46 B20 B	B	42
340 i	07.2016 →	B58 B30 A	B	26	320 i	09.2005 → 06.2012	N46 B20 BD	B	42
340 i xDrive	07.2016 →	B58 B30 A	B	26	320 i	09.2005 → 06.2012	N46 B20 C	B	45
340 i xDrive	07.2016 →	B58 B30 A	B	26	320 i	09.2005 → 06.2012	N46 B20 C	B	45
<b>3 Touring (E30)</b>					320 i	02.2007 → 05.2012	N43 B20 A	B	48
316 i	09.1991 → 06.1994	M40 B16 (164E1)	B	36	320 i	02.2007 → 12.2012	N43 B20 A	B	48
316 i	09.1991 → 06.1994	M40 B16 (164E1)	B	36	323 i	04.2006 → 06.2007	N52 B25 A	B	22
318 i	09.1987 → 06.1991	M40 B18 (184E1)	B	35	323 i	09.2006 → 07.2008	N52 B25 A	B	22
318 i	04.1989 → 06.1994	M40 B18 (184E1)	B	35	325 d	09.2006 → 06.2012	M57 D30 (306D3)	D	60
324 td	01.1988 → 06.1993	M21 D24 (246TB)	D	14	325 d	02.2010 → 06.2012	N57 D30 A	D	62
<b>3 Touring (E36)</b>					325 i	12.2004 → 08.2008	N52 B25 A	B	22
316 i	03.1997 → 05.1999	M43 B16 (164E2)	BG	32	325 i	12.2004 → 12.2010	N52 B25 A	B	22
318 i	09.1995 → 04.1999	M43 B18 (184E2)	AB	56	325 i	12.2004 → 12.2010	N52 B25 AF	B	22
318 tds	03.1995 → 04.1999	M41 D17 (174T1)	D	15	325 i	12.2004 → 12.2010	N52 B25 B	B	22
320 i	01.1995 → 04.1999	M52 B20 (206S3)	B	10	325 i	12.2004 → 12.2010	N52 B25 BF	B	22
323 i	12.1995 → 04.1999	M52 B25 (256S3)	B	40	325 i	09.2007 → 06.2012	N53 B30 A	B	73
328 i	02.1995 → 04.1999	M52 B28 (286S1)	B	40	325 i	09.2007 → 06.2012	N53 B30 A	B	73
<b>3 Touring (E46)</b>					325 i xDrive	09.2008 → 06.2012	N53 B30 A	B	73
316 i	03.2002 → 02.2005	N42 B18 A	B	42	325 i xDrive	09.2008 → 06.2012	N53 B30 A	B	73
316 i	03.2002 → 02.2005	N46 B18 A	B	42	325 xi	08.2005 → 08.2008	N52 B25 A	B	22
318 d	10.2002 → 03.2003	M47 D20 (204D1)	D	59	325 xi	09.2007 → 08.2008	N53 B30 A	B	73
318 d	03.2003 → 02.2005	M47 D20 (204D4)	D	59	325 xi	09.2007 → 08.2008	N53 B30 A	B	73
318 i	09.2001 → 02.2004	N42 B20 A	B	42	328 i	03.2007 → 06.2012	N52 B30 A	B	71
318 i	03.2004 → 07.2005	N46 B20 A	B	42	330 d	12.2004 → 08.2008	M57 D30 (306D3)	D	60
318 i	03.2004 → 07.2005	N46 B20 C	B	45	330 d	06.2005 → 05.2012	M57 D30 (306D3)	D	60
320 d	03.2000 → 09.2001	M47 D20 (204D1)	D	59	330 d	06.2005 → 05.2012	N57 D30 A	D	62
320 d	09.2001 → 02.2005	M47 D20 (204D4)	D	59	330 d	02.2008 → 05.2012	N57 D30 A	D	62
320 i	10.1999 → 09.2000	M52 B20 (206S4)	B	10	330 d xDrive	01.2009 → 06.2012	N57 D30 A	D	62
320 i	09.2000 → 02.2005	M54 B22 (226S1)	B	11	330 i	08.2005 → 08.2007	N52 B30 A	B	71
320 i	09.2000 → 02.2005	M54 B22 (226S1)	B	11	330 i	03.2007 → 06.2012	N52 B30 A	B	71
323 i	10.1999 → 12.2000	M52 B25 (256S3)	B	40	330 i	09.2007 → 06.2012	N53 B30 A	B	73
325 i	09.2000 → 02.2005	M54 B25 (256S5)	B	40	330 i xDrive	09.2007 → 06.2012	N53 B30 A	B	73
325 i	09.2000 → 02.2005	M54 B25 (256S5)	B	40	330 xd	09.2005 → 06.2012	M57 D30 (306D3)	D	60
325 xi	09.2000 → 02.2005	M54 B25 (256S5)	B	40	330 xi	09.2005 → 08.2007	N52 B30 A	B	71
325 xi	09.2000 → 02.2005	M54 B25 (256S5)	B	40	330 xi	09.2007 → 06.2012	N53 B30 A	B	73
328 i	06.1999 → 05.2000	M52 B28 (286S2)	B	40	335 d	09.2006 → 06.2012	M57 D30 (306D5)	D	60
330 d	10.1999 → 02.2005	M57 D30 (306D1)	D	59	335 i	09.2006 → 06.2012	N54 B30 A	B	47
330 d	03.2003 → 02.2005	M57 D30 (306D2)	D	60	335 i	09.2006 → 06.2012	N54 B30 A	B	47
330 i	06.2000 → 02.2005	M54 B30 (306S3)	B	40	335 i	09.2006 → 06.2012	N55 B30 A	B	46
330 xd	01.2000 → 03.2003	M57 D30 (306D1)	D	59	335 i	09.2006 → 06.2012	N55 B30 A	B	46
330 xd	08.2002 → 05.2005	M57 D30 (306D2)	D	60	335 i xDrive	09.2008 → 06.2012	N54 B30 A	B	47
330 xi	06.2000 → 02.2005	M54 B30 (306S3)	B	40	335 i xDrive	09.2008 → 06.2012	N54 B30 A	B	47
<b>3 Touring (E91)</b>					335 i xDrive	09.2008 → 06.2012	N55 B30 A	B	46
316 d	09.2009 → 06.2012	N47 D20 C	D	61	335 i xDrive	09.2008 → 06.2012	N55 B30 A	B	46
316 i	09.2008 → 06.2012	N43 B16 AA	B	23	335 xi	03.2007 → 08.2008	N54 B30 A	B	47
318 d	09.2005 → 08.2007	M47 D20 (204D4)	D	59	335 xi	03.2007 → 08.2008	N54 B30 A	B	47
318 d	07.2007 → 08.2008	N47 D20 A	D	61	335 xi	03.2007 → 08.2008	N55 B30 A	B	46
318 d	09.2007 → 06.2012	N47 D20 A	D	61	<b>3 Touring (F31)</b>				
318 d	09.2007 → 06.2012	N47 D20 C	D	61	316 d	11.2012 → 06.2019	B47 D20 A	D	63



			Pos				Pos			
B	316 d	11.2012 → 06.2019	N47 D20 C	D	61	320 d xDrive	07.2019 → 02.2020	B47 D20 B	D	64
	316 i	03.2013 → 06.2015	N13 B16 A	B	5	320 d xDrive	07.2019 → 02.2020	B47 D20 B	D	64
	318 d	11.2012 → 06.2015	N47 D20 C	D	61	320 e Plug-in-Hybrid	07.2020 →	B48 B20 A	AB	31
	318 d	11.2012 → 06.2019	B47 D20 A	D	63	320 e Plug-in-Hybrid	07.2020 →	B48 B20 A	AB	31
	318 d	11.2012 → 06.2019	N47 D20 C	D	61	320 i	11.2019 →	B48 B20 A	AB	31
	318 d	07.2015 → 06.2019	B47 D20 A	D	63	330 d	11.2019 →	B57 D30 A	D	63
	318 d xDrive	07.2013 → 06.2015	N47 D20 C	D	61	330 d Mild-Hybrid	11.2020 →	B57 D30 B	D	62
	318 d xDrive	07.2015 → 02.2018	B47 D20 A	D	63	330 d Mild-Hybrid	11.2020 →	B57 D30 B	D	62
	318 i	07.2015 → 06.2019	B38 B15 A	B	27	xDrive				
	320 d	07.2012 → 02.2016	N47 D20 C	D	61	330 d xDrive	07.2019 →	B57 D30 A	D	63
	320 d	07.2012 → 02.2016	N47 D20 C	D	61	330 e Plug-in-Hybrid	07.2020 →	B48 B20 A	AB	31
	320 d	07.2012 → 06.2019	B47 D20 A	D	63	330 e Plug-in-Hybrid	07.2020 →	B48 B20 A	AB	31
	320 d	07.2012 → 06.2019	N47 D20 C	D	61	330 e Plug-in-Hybrid	07.2020 →	B48 B20 A	AB	31
	320 d	07.2015 → 06.2019	B47 D20 A	D	63	xDrive				
	320 d xDrive	03.2013 → 06.2015	N47 D20 C	D	61	330 e Plug-in-Hybrid	07.2020 →	B48 B20 A	AB	31
	320 d xDrive	03.2013 → 06.2015	N47 D20 C	D	61	xDrive				
	320 d xDrive	03.2013 → 06.2015	N47 D20 C	D	61	330 i	07.2019 →	B48 B20 B	B	26
	320 d xDrive	07.2015 → 06.2019	B47 D20 A	D	63	330 i xDrive	07.2019 →	B48 B20 B	B	26
	320 d xDrive	07.2015 → 06.2019	B47 D20 A	D	63	M 340 d Mild-Hybrid	04.2020 →	B57 D30 B	D	62
	320 i	11.2012 → 06.2015	N20 B20 B	B	46	xDrive				
	320 i	11.2012 → 06.2015	N20 B20 B	B	46	<b>4 Convertible (F33, F83)</b>				
	320 i	07.2015 → 06.2019	B48 B20 A	AB	31	420 d	10.2013 → 06.2015	N47 D20 C	D	61
	320 i xDrive	03.2013 → 06.2015	N20 B20 B	B	46	420 d	10.2013 → 06.2015	N47 D20 C	D	61
	320 i xDrive	03.2013 → 06.2015	N20 B20 B	B	46	420 d	11.2013 → 06.2015	N47 D20 C	D	61
	320 i xDrive	07.2015 → 06.2019	B48 B20 A	AB	31	420 d	07.2015 →	B47 D20 A	D	63
	325 d	03.2013 → 02.2016	N47 D20 D	D	61	420 d	07.2015 →	B47 D20 A	D	63
	325 d	03.2013 → 02.2016	N47 D20 D	D	61	420 i	07.2014 → 02.2016	N20 B20 B	B	46
	325 d	03.2016 → 02.2018	B47 D20 B	D	64	420 i	07.2014 → 02.2016	N20 B20 B	B	46
	328 i	07.2012 → 06.2015	N20 B20 A	AB	57	420 i	03.2016 →	B48 B20 A	AB	31
	328 i xDrive	03.2013 → 06.2016	N20 B20 A	AB	57	420 i	03.2016 →	B48 B20 A	AB	31
	330 d	07.2012 → 06.2019	N57 D30 A	D	62	425 d	07.2014 → 02.2016	N47 D20 D	D	61
	330 d	07.2012 → 06.2019	N57 D30 A	D	62	425 d	07.2014 → 02.2016	N47 D20 D	D	61
	330 d xDrive	03.2013 → 06.2019	N57 D30 A	D	62	425 d	03.2016 → 02.2018	B47 D20 B	D	64
	330 d xDrive	03.2013 → 06.2019	N57 D30 A	D	62	425 i	06.2017 →	B48 B20 A	AB	31
	330 i	07.2015 → 06.2019	B48 B20 A	AB	31	428 i	11.2013 → 02.2016	N20 B20 A	AB	57
	330 i xDrive	07.2015 → 06.2019	B48 B20 A	AB	31	428 i	11.2013 → 02.2017	N26 B20 A	B	49
	330 i xDrive	07.2015 → 06.2019	B48 B20 B	B	26	428 i xDrive	03.2014 → 02.2016	N20 B20 A	AB	57
	335 d xDrive	11.2013 → 06.2019	N57 D30 B	D	63	428 i xDrive	03.2014 → 02.2016	N26 B20 A	B	49
	335 i	03.2013 → 06.2013	N55 B30 A	B	46	430 d	07.2014 →	N57 D30 A	D	62
	335 i	03.2013 → 06.2015	N55 B30 A	B	46	430 d	07.2014 →	N57 D30 A	D	62
	335 i	07.2013 → 06.2015	N55 B30 A	B	46	430 i	03.2016 →	B48 B20 B	B	26
	335 i xDrive	03.2013 → 06.2013	N55 B30 A	B	46	430 i xDrive	03.2016 →	B48 B20 B	B	26
	335 i xDrive	03.2013 → 06.2015	N55 B30 A	B	46	435 d xDrive	07.2014 →	N57 D30 B	D	63
	335 i xDrive	07.2013 → 06.2015	N55 B30 A	B	46	435 i	11.2013 → 02.2016	N55 B30 A	B	46
	340 i	07.2015 → 06.2019	B58 B30 A	B	26	435 i	11.2013 → 02.2016	N55 B30 A	B	46
	340 i	07.2015 → 06.2019	B58 B30 A	B	26	435 i xDrive	07.2014 → 02.2016	N55 B30 A	B	46
	340 i xDrive	07.2015 → 06.2019	B58 B30 A	B	26	435 i xDrive	07.2014 → 02.2016	N55 B30 A	B	46
	340 i xDrive	07.2015 → 06.2019	B58 B30 A	B	26	440 i	03.2016 →	B58 B30 A	B	26
						440 i	03.2016 →	B58 B30 A	B	26
						440 i xDrive	03.2016 →	B58 B30 A	B	26
						440 i xDrive	03.2016 →	B58 B30 A	B	26
	<b>3 Touring (G21, G81)</b>									
	316 d	11.2020 →	B47 D20 B	D	64	<b>4 Convertible (G23, G83)</b>				
	316 d	11.2020 →	B47 D20 B	D	64	420 d Mild-Hybrid	11.2020 →	B47 D20 B	D	64
	316 d Mild-Hybrid	07.2020 →	B47 D20 B	D	64	420 d Mild-Hybrid	11.2020 →	B47 D20 B	D	64
	316 d Mild-Hybrid	11.2020 →	B47 D20 B	D	64	420 i	11.2020 →	B48 B20 A	AB	31
	318 d	11.2019 → 07.2020	B47 D20 B	D	64	430 d Mild-Hybrid	07.2021 →	B57 D30 B	D	62
	318 d	11.2019 → 07.2020	B47 D20 B	D	64	430 i	11.2020 →	B48 B20 B	B	26
	318 d Mild-Hybrid	08.2020 →	B47 D20 B	D	64	M440 d Mild-Hybrid	11.2021 →	B57 D30 B	D	62
	318 d Mild-Hybrid	08.2020 →	B47 D20 B	D	64	xDrive				
	318 i	03.2020 →	B48 B20 A	AB	31	<b>4 Coupe (F32, F82)</b>				
	320 E PLUG-IN-HYBRID XDRIVE	03.2021 →	B48 B20 A	AB	31	418 d	03.2015 → 10.2017	B47 D20 A	D	63
	320 E PLUG-IN-HYBRID XDRIVE	03.2021 →	B48 B20 A	AB	31	418 d	03.2015 → 10.2017	B47 D20 A	D	63
	320 d	07.2019 → 02.2020	B47 D20 B	D	64	418 i	03.2016 →	B38 B15 A	B	27
	320 d	07.2019 → 02.2020	B47 D20 B	D	64	420 d	07.2013 → 02.2015	N47 D20 C	D	61
	320 d Mild-Hybrid	03.2020 →	B47 D20 B	D	64	420 d	07.2013 → 02.2015	N47 D20 C	D	61
	320 d Mild-Hybrid	03.2020 →	B47 D20 B	D	64	420 d	07.2013 → 03.2015	N47 D20 C	D	61
	320 d Mild-Hybrid	03.2020 →	B47 D20 B	D	64	420 d	03.2015 → 02.2015	B47 D20 A	D	63
	xDrive					420 d	03.2015 →	B47 D20 A	D	63
	320 d Mild-Hybrid	03.2020 →	B47 D20 B	D	64	420 d xDrive	11.2013 → 02.2015	N47 D20 C	D	61
	xDrive					420 d xDrive	11.2013 → 02.2015	N47 D20 C	D	61

				Pos					Pos
420 d xDrive	11.2013 → 03.2015	N47 D20 C	D	61	420 d xDrive	03.2015 →	B47 D20 A	D	63
420 d xDrive	03.2015 →	B47 D20 A	D	63	420 i	03.2014 → 02.2017	N20 B20 B	B	46
420 d xDrive	03.2015 →	B47 D20 A	D	63	420 i	03.2014 → 02.2017	N20 B20 B	B	46
420 i	11.2013 → 02.2017	N20 B20 A	AB	57	420 i	03.2016 →	B48 B20 A	AB	31
420 i	11.2013 → 02.2017	N20 B20 A	AB	57	420 i	03.2016 →	B48 B20 A	AB	31
420 i	11.2013 → 02.2017	N20 B20 B	B	46	420 i xDrive	07.2014 → 02.2016	N20 B20 B	B	46
420 i	11.2013 → 02.2017	N20 B20 B	B	46	420 i xDrive	07.2014 → 02.2016	N20 B20 B	B	46
420 i	03.2016 →	B48 B20 A	AB	31	420 i xDrive	03.2016 →	B48 B20 A	AB	31
420 i	03.2016 →	B48 B20 A	AB	31	420 i xDrive	03.2016 →	B48 B20 A	AB	31
420 i xDrive	11.2013 → 02.2016	N20 B20 A	AB	57	425 d	03.2016 → 02.2018	B47 D20 B	D	64
420 i xDrive	11.2013 → 02.2016	N20 B20 A	AB	57	425 d	03.2016 → 02.2018	B47 D20 B	D	64
420 i xDrive	11.2013 → 02.2016	N20 B20 B	B	46	425 i	06.2017 →	B48 B20 A	AB	31
420 i xDrive	11.2013 → 02.2016	N20 B20 B	B	46	428 i	03.2014 → 06.2016	N20 B20 A	AB	57
420 i xDrive	03.2016 →	B48 B20 A	AB	31	428 i	03.2014 → 06.2016	N26 B20 A	B	49
420 i xDrive	03.2016 →	B48 B20 A	AB	31	428 i xDrive	03.2014 → 02.2016	N20 B20 A	AB	57
425 d	03.2014 → 02.2016	N47 D20 D	D	61	428 i xDrive	03.2014 → 02.2016	N26 B20 A	B	49
425 d	03.2014 → 02.2016	N47 D20 D	D	61	430 d	07.2014 →	N57 D30 A	D	62
425 d	03.2016 → 10.2017	B47 D20 B	D	64	430 d	07.2014 →	N57 D30 A	D	62
425 i	06.2017 →	B48 B20 A	AB	31	430 d xDrive	07.2014 →	N57 D30 A	D	62
428 i	07.2013 → 06.2016	N20 B20 A	AB	57	430 d xDrive	07.2014 →	N57 D30 A	D	62
428 i	07.2013 → 02.2017	N26 B20 A	B	49	430 i	03.2016 →	B48 B20 B	B	26
428 i xDrive	07.2013 → 02.2016	N20 B20 A	AB	57	430 i xDrive	03.2016 →	B48 B20 B	B	26
428 i xDrive	07.2013 → 02.2016	N26 B20 A	B	49	430 i xDrive	03.2016 →	B48 B20 B	B	26
430 d	11.2013 →	N57 D30 A	D	62	435 d xDrive	07.2014 →	N57 D30 B	D	63
430 d	11.2013 →	N57 D30 A	D	62	435 i	03.2014 → 02.2016	N55 B30 A	B	46
430 d xDrive	03.2014 →	N57 D30 A	D	62	435 i	03.2014 → 02.2016	N55 B30 A	B	46
430 d xDrive	03.2014 →	N57 D30 A	D	62	435 i xDrive	07.2014 → 02.2016	N55 B30 A	B	46
430 i	03.2016 →	B48 B20 B	B	26	435 i xDrive	07.2014 → 02.2016	N55 B30 A	B	46
430 i	03.2016 →	B48 B20 B	B	26	440 i	03.2016 →	B58 B30 A	B	26
430 i xDrive	03.2016 →	B48 B20 B	B	26	440 i	03.2016 →	B58 B30 A	B	26
430 i xDrive	03.2016 →	B48 B20 B	B	26	440 i xDrive	03.2016 →	B58 B30 A	B	26
435 d xDrive	11.2013 → 12.2020	N57 D30 B	D	63	440 i xDrive	03.2016 →	B58 B30 A	B	26
435 i	07.2013 → 02.2016	N55 B30 A	B	46	<b>4 Gran Coupe (G26)</b>				
435 i	07.2013 → 02.2016	N55 B30 A	B	46	420 d Mild-Hybrid	07.2021 →	B47 D20 B	D	64
435 i xDrive	07.2013 → 02.2016	N55 B30 A	B	46	420 d Mild-Hybrid	07.2021 →	B47 D20 B	D	64
435 i xDrive	07.2013 → 02.2016	N55 B30 A	B	46	xDrive				
440 i	03.2016 →	B58 B30 A	B	26	420 i	07.2021 →	B48 B20 A	AB	31
440 i	03.2016 →	B58 B30 A	B	26	430 i	07.2021 →	B48 B20 B	B	26
440 i xDrive	03.2016 →	B58 B30 A	B	26	<b>5 (E12)</b>				
440 i xDrive	03.2016 →	B58 B30 A	B	26	518	07.1974 → 05.1981	M10 B18 (184VB)	B	77
<b>4 Coupe (G22, G82)</b>					518 i	06.1979 → 06.1981	M10 B18 (184EB)	B	77
420 d Mild-Hybrid	07.2020 →	B47 D20 B	D	64	520	06.1972 → 01.1979	M10 B20	B	77
420 d Mild-Hybrid	07.2020 →	B47 D20 B	D	64	520 2.0 (USA)	01.1972 → 12.1974	M10 B20	B	77
420 d Mild-Hybrid	07.2020 →	B47 D20 B	D	64	520 i	03.1972 → 07.1979	M10 B20	B	77
420 d Mild-Hybrid	07.2020 →	B47 D20 B	D	64	520 i	08.1972 → 10.1973	M10 B20	B	77
420 i	07.2020 →	B48 B20 A	AB	31	528	01.1975 → 08.1976	M30 B28	B	75
420 i xDrive	07.2021 →	B48 B20 A	AB	31	528	08.1975 → 07.1977	M30 B28	B	75
430 d Mild-Hybrid	03.2021 →	B57 D30 B	D	62	528 i	03.1977 → 09.1979	M30 B28	B	75
430 i	07.2020 →	B48 B20 B	B	26	528 i	08.1979 → 06.1981	M30 B28	B	75
430 i xDrive	07.2021 →	B48 B20 B	B	26	528i	01.1975 → 06.1981	M30 B28	B	75
M440 d Mild-Hybrid	03.2021 →	B57 D30 B	D	62	530 i	09.1974 → 12.1978	M30 B30	B	78
<b>4 Gran Coupe (F36)</b>					530i 3.0 (USA)	01.1975 → 1978	M30 B30	B	78
418 d	03.2014 → 06.2015	N47 D20 C	D	61	530i 3.0 (USA)	01.1975 → 1978	M30 B30 (306EA)	B	78
418 d	03.2014 → 06.2015	N47 D20 C	D	61	530i 3.0 (USA)	01.1975 → 1978	M30 B30 (306KA)	B	78
418 d	07.2015 → 06.2015	B47 D20 A	D	63	<b>5 (E28)</b>				
418 d	07.2015 →	B47 D20 A	D	63	518	06.1981 → 09.1984	M10 B18 (184VC)	B	77
418 i	07.2015 →	B38 B15 A	B	27	518	06.1981 → 09.1984	M10 B18 (184VD)	B	77
420 d	03.2014 → 02.2015	N47 D20 C	D	61	518 i	05.1981 → 12.1987	M10 B18 (184EB)	B	77
420 d	03.2014 → 02.2015	N47 D20 C	D	61	518 i	05.1981 → 12.1987	M10 B18 (184EB)	B	77
420 d	03.2014 → 02.2015	N47 D20 C	D	61	524 d	03.1986 → 12.1987	M21 D24 (246DA)	D	14
420 d	03.2014 → 02.2015	N47 D20 C	D	61	524 td	09.1983 → 12.1987	M21 D24 (246TA)	D	14
420 d	03.2014 → 02.2015	N47 D20 C	D	61	528e 2.7i (USA)	12.1984 → 12.1987	M20 B27 ME.U	B	34
420 d	03.2015 → 02.2015	B47 D20 A	D	63	533 i	09.1982 → 12.1984	M30 B32	B	78
420 d	03.2015 →	B47 D20 A	D	63	<b>5 (E34)</b>				
420 d xDrive	03.2014 → 02.2015	N47 D20 C	D	61	518 i	09.1989 → 04.1994	M40 B18 (184E1)	B	35
420 d xDrive	03.2014 → 02.2015	N47 D20 C	D	61	518 i	05.1994 → 08.1995	M43 B18 (184E2)	AB	56
420 d xDrive	03.2014 → 02.2015	N47 D20 C	D	61	520 i 24V	04.1990 → 08.1995	M50 B20 (206S1)	B	9
420 d xDrive	03.2014 → 02.2015	N47 D20 C	D	61	520 i 24V	04.1990 → 08.1995	M50 B20 (206S2)	B	9
420 d xDrive	03.2015 → 02.2015	B47 D20 A	D	63	524 td	03.1988 → 08.1991	M21 D24 (246TB)	D	14

**B**

			Pos				Pos	
<b>B</b>	530 i	01.1988 → 04.1990	M30 B30 (306KA) B	<b>78</b>	530 d xDrive	09.2007 → 12.2009	M57 D30 (306D3) D	<b>60</b>
	530 i V8	09.1992 → 12.1995	M60 B30 (308S1) B	<b>39</b>	530 i	12.2001 → 02.2005	M54 B30 (306S3) B	<b>40</b>
	540 i V8	09.1992 → 12.1995	M60 B40 (408S1) B	<b>79</b>	530 i	01.2004 → 12.2005	M54 B30 (306S3) B	<b>40</b>
	<b>5 (E39)</b>				530 i	03.2005 → 03.2007	N52 B30 A B	<b>71</b>
	520 d	02.2000 → 06.2003	M47 D20 (204D1) D	<b>59</b>	530 i	03.2005 → 03.2007	N52 B30 BF B	<b>71</b>
	520 i	01.1996 → 08.1998	M52 B20 (206S3) B	<b>10</b>	530 i	03.2005 → 03.2010	N52 B30 A B	<b>71</b>
	520 i	01.1996 → 08.1998	M52 B20 (206S3) B	<b>10</b>	530 i	03.2007 → 12.2009	N52 B30 A B	<b>71</b>
	520 i	09.1998 → 06.2003	M52 B20 (206S4) B	<b>10</b>	530 i	03.2007 → 12.2009	N52 B30 BF B	<b>71</b>
	520 i	09.1998 → 06.2003	M52 B20 (206S4) B	<b>10</b>	530 i	03.2007 → 12.2009	N53 B30 A B	<b>73</b>
	520 i	09.2000 → 06.2003	M54 B22 (226S1) B	<b>11</b>	530 i	09.2007 → 12.2009	N52 B30 A B	<b>71</b>
	520 i	09.2000 → 06.2003	M54 B22 (226S1) B	<b>11</b>	530 i xDrive	09.2008 → 12.2009	N53 B30 A B	<b>73</b>
	523 i	09.1995 → 08.1998	M52 B25 (256S3) B	<b>40</b>	530 xd	02.2005 → 02.2007	M57 D30 (306D3) D	<b>60</b>
	523 i	09.1998 → 08.2000	M52 B25 (256S4) B	<b>40</b>	530 xd	03.2007 → 08.2007	M57 D30 (306D3) D	<b>60</b>
	525 d	02.2000 → 06.2003	M57 D25 (256D1) D	<b>16</b>	530 xi	09.2004 → 02.2007	N52 B30 A B	<b>71</b>
	525 i	09.2000 → 12.2002	M54 B25 (256S5) B	<b>40</b>	530 xi	02.2007 → 08.2008	N53 B30 A B	<b>73</b>
	525 i	09.2000 → 06.2003	M54 B25 (256S5) B	<b>40</b>	530 xi	03.2007 → 10.2009	N52 B30 A B	<b>71</b>
	528 i	09.1995 → 08.2000	M52 B28 (286S1) B	<b>40</b>	535 d	09.2004 → 03.2010	M57 D30 (306D4) D	<b>60</b>
	528 i	09.1995 → 08.2000	M52 B28 (286S2) B	<b>40</b>	535 d	01.2007 → 03.2010	M57 D30 (306D5) D	<b>60</b>
	530 d	08.1998 → 09.2000	M57 D30 (306D1) D	<b>59</b>	535 i	04.2006 → 12.2009	N54 B30 A B	<b>47</b>
	530 d	09.1998 → 06.2003	M57 D30 (306D1) D	<b>59</b>	535 i	09.2007 → 03.2010	N54 B30 A B	<b>47</b>
	530 i	09.2000 → 06.2003	M54 B30 (306S3) B	<b>40</b>	535 i xDrive	09.2008 → 12.2009	N54 B30 A B	<b>47</b>
	530 i	09.2000 → 06.2003	M54 B30 (306S3) B	<b>40</b>	535 xi	03.2007 → 08.2008	N54 B30 A B	<b>47</b>
	535 i	06.1996 → 08.1998	M62 B35 (358S1) B	<b>39</b>	545 i	09.2003 → 08.2005	N62 B44 A B	<b>88</b>
	535 i	09.1998 → 06.2003	M62 B35 (358S2) B	<b>39</b>	545 i	09.2003 → 12.2005	N62 B44 A B	<b>88</b>
	540 i	03.1996 → 06.2003	M62 B44 (448S1) B	<b>87</b>	550 i	09.2005 → 12.2009	N62 B48 B B	<b>91</b>
	540 i	03.1996 → 06.2003	M62 B44 (448S2) B	<b>87</b>	550 i	09.2005 → 03.2010	N62 B48 B B	<b>91</b>
	540 i	01.2002 → 06.2003	M62 B44 (448S2) B	<b>87</b>	550i 4.4 32V	10.2007 → 05.2010	N63 B44 A B	<b>80</b>
	M5	10.1998 → 06.2003	S62 B50 (508S1) B	<b>94</b>	<b>5 (E61)</b>			
	<b>5 (E60)</b>				550i 4.4 32V	10.2007 → 05.2010	N63 B44 A B	<b>80</b>
	520 d	09.2005 → 02.2007	M47 D20 (204D4) D	<b>59</b>	<b>5 (F10)</b>			
	520 d	09.2005 → 12.2009	M47 D20 (204D4) D	<b>59</b>	518 d	07.2013 → 06.2014	N47 D20 C D	<b>61</b>
	520 d	09.2005 → 12.2009	N47 D20 C D	<b>61</b>	518 d	07.2013 → 06.2014	N47 D20 C D	<b>61</b>
	520 d	09.2007 → 12.2009	N47 D20 A D	<b>61</b>	518 d	10.2013 → 10.2016	B47 D20 A D	<b>63</b>
	520 d	09.2007 → 12.2009	N47 D20 A D	<b>61</b>	518 d	07.2014 → 10.2016	B47 D20 A D	<b>63</b>
	520 d	09.2008 → 12.2009	N47 D20 C D	<b>61</b>	520 d	06.2010 → 06.2014	N47 D20 C D	<b>61</b>
	520 i	07.2003 → 03.2010	M54 B22 (226S1) B	<b>11</b>	520 d	06.2010 → 06.2014	N47 D20 C D	<b>61</b>
	520 i	12.2006 → 03.2010	N43 B20 A B	<b>48</b>	520 d	06.2010 → 10.2016	N47 D20 C D	<b>61</b>
	520 i	09.2007 → 12.2009	N43 B20 A B	<b>48</b>	520 d	01.2013 → 06.2014	N47 D20 C D	<b>61</b>
	520 i	09.2007 → 02.2010	N46 B20 B B	<b>42</b>	520 d	10.2013 → 10.2016	B47 D20 A D	<b>63</b>
	523 i	10.2004 → 02.2007	N52 B25 A B	<b>22</b>	520 d	07.2014 → 10.2016	B47 D20 A D	<b>63</b>
	523 i	10.2004 → 02.2007	N52 B25 B B	<b>22</b>	520 d	07.2014 → 10.2016	B47 D20 A D	<b>63</b>
	523 i	10.2004 → 02.2007	N52 B25 BE B	<b>22</b>	520 d	07.2014 → 10.2016	B47 D20 A D	<b>63</b>
	523 i	03.2007 → 12.2009	N52 B25 A B	<b>22</b>	520 d xDrive	01.2013 → 06.2014	N47 D20 C D	<b>61</b>
	523 i	03.2007 → 12.2009	N52 B25 BE B	<b>22</b>	520 d xDrive	01.2013 → 06.2014	N47 D20 C D	<b>61</b>
	523 i	03.2007 → 12.2009	N53 B25 A B	<b>22</b>	520 d xDrive	07.2013 → 06.2014	N47 D20 C D	<b>61</b>
	525 d	06.2004 → 03.2010	M57 D25 (256D2) D	<b>16</b>	520 d xDrive	10.2013 → 10.2016	B47 D20 A D	<b>63</b>
	525 d	12.2004 → 03.2010	M57 D25 (256D2) D	<b>16</b>	520 d xDrive	10.2013 → 10.2016	B47 D20 A D	<b>63</b>
	525 d	01.2007 → 03.2010	M57 D30 (306D3) D	<b>60</b>	520 d xDrive	07.2014 → 10.2016	B47 D20 A D	<b>63</b>
	525 d xDrive	09.2007 → 12.2009	M57 D30 (306D3) D	<b>60</b>	520 d xDrive	07.2014 → 10.2016	B47 D20 A D	<b>63</b>
	525 i	07.2003 → 12.2009	M54 B25 (256S5) B	<b>40</b>	520 i	09.2011 → 10.2016	N20 B20 A AB	<b>57</b>
	525 i	09.2003 → 02.2005	M54 B25 (256S5) B	<b>40</b>	520 i	09.2011 → 10.2016	N20 B20 A AB	<b>57</b>
	525 i	03.2005 → 03.2007	N52 B30 A B	<b>71</b>	520 i	09.2011 → 10.2016	N20 B20 B B	<b>46</b>
	525 i	03.2005 → 12.2009	N52 B25 A B	<b>22</b>	520 i	09.2011 → 10.2016	N20 B20 B B	<b>46</b>
	525 i	03.2005 → 12.2009	N52 B25 B B	<b>22</b>	523 i	06.2009 → 08.2011	N53 B30 A B	<b>73</b>
	525 i	03.2005 → 12.2009	N52 B25 BF B	<b>22</b>	523 i	01.2010 → 08.2011	N52 B25 A B	<b>22</b>
	525 i	07.2005 → 03.2010	N52 B25 A B	<b>22</b>	523 i	01.2010 → 08.2011	N52 B25 AF B	<b>22</b>
	525 i	01.2007 → 03.2010	N53 B30 A B	<b>73</b>	523 i	01.2010 → 08.2011	N52 B25 B B	<b>22</b>
	525 i	01.2007 → 03.2010	N53 B30 A B	<b>73</b>	523 i	01.2010 → 08.2011	N52 B25 BF B	<b>22</b>
	525 i xDrive	09.2008 → 03.2010	N53 B30 A B	<b>73</b>	523 i	01.2010 → 08.2011	N53 B30 A B	<b>73</b>
	525 xd	11.2006 → 08.2007	M57 D30 (306D3) D	<b>60</b>	525 d	03.2010 → 08.2011	N57 D30 A D	<b>62</b>
	525 xi	04.2005 → 02.2007	N52 B25 A B	<b>22</b>	525 d	09.2011 → 10.2016	N47 D20 D D	<b>61</b>
	525 xi	03.2007 → 12.2009	N53 B30 A B	<b>73</b>	525 d	09.2011 → 10.2016	N47 D20 D D	<b>61</b>
	528 i	03.2007 → 12.2009	N52 B30 A B	<b>71</b>	525 d xDrive	09.2011 → 10.2016	N47 D20 D D	<b>61</b>
	528 i xDrive	09.2006 → 12.2009	N52 B30 A B	<b>71</b>	525 d xDrive	09.2011 → 10.2016	N47 D20 D D	<b>61</b>
	530 d	09.2002 → 09.2005	M57 D30 (306D2) D	<b>60</b>	528 i	10.2009 → 08.2011	N52 B30 A B	<b>71</b>
	530 d	09.2002 → 12.2009	M57 D30 (306D2) D	<b>60</b>	528 i	03.2010 → 08.2011	N53 B30 A B	<b>73</b>
	530 d	09.2002 → 12.2009	M57 D30 (306D3) D	<b>60</b>	528 i	09.2011 → 10.2016	N20 B20 A AB	<b>57</b>
	530 d	09.2005 → 03.2007	M57 D30 (306D3) D	<b>60</b>	528 i	10.2014 → 10.2016	N20 B20 A AB	<b>57</b>
	530 d	02.2007 → 12.2009	M57 D30 (306D3) D	<b>60</b>	528 i xDrive	09.2011 → 10.2016	N20 B20 A AB	<b>57</b>



			Pos				Pos		
530 d	01.2010 → 08.2011	N57 D30 A	D	62	530 d Mild-Hybrid	07.2020 →	B57 D30 B	D	62
530 d	09.2010 → 10.2016	N57 D30 A	D	62	xDrive				
530 d	09.2011 → 10.2016	N57 D30 A	D	62	530 d xDrive	09.2016 → 06.2020	B57 D30 A	D	63
530 d xDrive	03.2011 → 10.2016	N57 D30 A	D	62	530 d xDrive	09.2016 → 06.2020	B57 D30 A	D	63
530 d xDrive	03.2011 → 10.2016	N57 D30 A	D	62	530 e Plug-in-Hybrid	03.2017 → 06.2020	B48 B20 A	AB	31
530 i	03.2010 → 06.2013	N52 B30 A	B	71	530 e Plug-in-Hybrid	03.2017 →	B48 B20 A	AB	31
530 i	03.2010 → 06.2013	N52 B30 AF	B	71	530 e Plug-in-Hybrid	07.2019 → 06.2020	B48 B20 A	AB	31
530 i	03.2010 → 06.2013	N52 B30 BF	B	71	530 e Plug-in-Hybrid	07.2019 →	B48 B20 A	AB	31
530 i	05.2011 → 06.2013	N53 B30 A	B	73	530 e Plug-in-Hybrid	07.2020 →	B48 B20 A	AB	31
535 d	09.2010 → 08.2011	N57 D30 B	D	63	530 e Plug-in-Hybrid	07.2020 →	B48 B20 A	AB	31
535 d	09.2011 → 10.2016	N57 D30 B	D	63	530 e Plug-in-Hybrid	07.2020 →	B48 B20 A	AB	31
535 d xDrive	09.2011 → 10.2016	N57 D30 B	D	63	530 e Plug-in-Hybrid	07.2019 → 06.2020	B48 B20 A	AB	31
535 i	01.2009 → 10.2016	N55 B30 A	B	46	xDrive				
535 i	01.2010 → 10.2016	N55 B30 A	B	46	530 e Plug-in-Hybrid	07.2019 → 06.2020	B48 B20 A	AB	31
535 i	07.2013 → 10.2016	N55 B30 A	B	46	xDrive				
535 i xDrive	03.2011 → 10.2016	N55 B30 A	B	46	530 e Plug-in-Hybrid	07.2019 →	B48 B20 A	AB	31
535 i xDrive	07.2013 → 10.2016	N55 B30 A	B	46	xDrive				
550 i	03.2010 → 06.2013	N63 B44 A	B	80	530 e Plug-in-Hybrid	07.2019 →	B48 B20 A	AB	31
550 i	09.2010 → 06.2013	N63 B44 A	B	80	xDrive				
550 i	07.2013 → 10.2016	N63 B44 B	B	80	530 e Plug-in-Hybrid	07.2020 →	B48 B20 A	AB	31
550 i	07.2013 → 10.2016	N63 B44 B	B	80	xDrive				
550 i xDrive	08.2010 → 06.2013	N63 B44 A	B	80	530 e Plug-in-Hybrid	07.2020 →	B48 B20 A	AB	31
550 i xDrive	09.2012 → 06.2013	N63 B44 A	B	80	xDrive				
550 i xDrive	07.2013 → 10.2016	N63 B44 B	B	80	530 i	09.2016 → 06.2020	B48 B20 B	B	26
550 i xDrive	08.2013 → 10.2016	N63 B44 B	B	80	530 i Mild-Hybrid	07.2020 →	B48 B20 B	B	26
ActiveHybrid	12.2011 → 10.2016	N55 B30 A	B	46	530 i Mild-Hybrid xDrive	07.2020 →	B48 B20 B	B	26
ActiveHybrid	12.2011 → 10.2016	N55 B30 A	B	46	530 i xDrive	09.2016 → 06.2020	B48 B20 B	B	26
M 550 d xDrive	03.2012 → 10.2016	N57 D30 C	D	63	530 i xDrive	09.2016 →	B48 B20 B	B	26
<b>5 (F10, F18)</b>					540 d Mild-Hybrid	07.2020 →	B57 D30 B	D	62
525Li 2.0 16V	07.2013 →	N20 B20 A	AB	57	xDrive				
550d 3.0 24V	01.2010 →	N57 D30 C	D	63	540 d xDrive	07.2017 → 06.2020	B57 D30 B	D	62
<b>5 (F11)</b>					540 i	09.2016 → 06.2020	B58 B30 A	B	26
550d 3.0 24V	07.2013 →	N57 D30 C	D	63	540 i	09.2016 → 06.2020	B58 B30 A	B	26
<b>5 (G30, F90)</b>					540 i xDrive	09.2016 → 06.2020	B58 B30 A	B	26
518 d	07.2018 → 06.2020	B47 D20 B	D	64	540 i xDrive	09.2016 → 06.2020	B58 B30 A	B	26
518 d	07.2018 → 06.2020	B47 D20 B	D	64	540 i xDrive	09.2016 → 06.2020	B58 B30 A	B	26
518 d Mild-Hybrid	07.2020 →	B47 D20 B	D	64	M 550 d xDrive	06.2017 →	B57 D30 C	D	65
518 d Mild-Hybrid	07.2020 →	B47 D20 B	D	64	M 550 i xDrive	03.2017 → 06.2019	N63 B44 C	B	82
520 E PLUG-IN-HYBRID	03.2021 →	B48 B20 A	AB	31	M 550 i xDrive	07.2019 →	N63 B44 D	B	83
520 E PLUG-IN-HYBRID	03.2021 →	B48 B20 A	AB	31	<b>5 Gran Turismo (F07)</b>				
520 d	09.2016 → 10.2019	B47 D20 A	D	63	520 d	04.2011 → 02.2017	N47 D20 C	D	61
520 d	09.2016 → 10.2019	B47 D20 A	D	63	520 d	07.2012 → 06.2013	N47 D20 C	D	61
520 d	09.2016 → 10.2019	B47 D20 B	D	64	520 d	07.2013 → 02.2017	N47 D20 C	D	61
520 d	09.2016 → 10.2019	B47 D20 B	D	64	528 i	07.2013 → 02.2017	N20 B20 A	AB	57
520 d	07.2018 → 10.2019	B47 D20 B	D	64	530 d	08.2009 → 06.2012	N57 D30 A	D	62
520 d Mild-Hybrid	11.2019 →	B47 D20 B	D	64	530 d	09.2010 → 02.2017	N57 D30 A	D	62
520 d Mild-Hybrid	11.2019 →	B47 D20 B	D	64	530 d	07.2012 → 02.2017	N57 D30 A	D	62
520 d Mild-Hybrid	11.2019 →	B47 D20 B	D	64	530 d xDrive	06.2010 → 06.2012	N57 D30 A	D	62
xDrive					530 d xDrive	07.2012 → 02.2017	N57 D30 A	D	62
520 d xDrive	09.2016 → 10.2019	B47 D20 A	D	63	535 d	03.2010 → 06.2012	N57 D30 B	D	63
520 d xDrive	09.2016 → 10.2019	B47 D20 A	D	63	535 d	07.2012 → 02.2017	N57 D30 B	D	63
520 d xDrive	09.2016 → 10.2019	B47 D20 B	D	64	535 d xDrive	03.2010 → 06.2012	N57 D30 B	D	63
520 d xDrive	07.2018 → 10.2019	B47 D20 B	D	64	535 d xDrive	07.2012 → 02.2017	N57 D30 B	D	63
520 i	07.2017 → 06.2020	B48 B20 A	AB	31	535 i	01.2009 → 02.2017	N55 B30 A	B	46
520 i	07.2017 → 06.2020	B48 B20 A	AB	31	535 i xDrive	09.2010 → 02.2017	N55 B30 A	B	46
520 i	07.2017 → 06.2020	B48 B20 A	AB	31	535 i xDrive	09.2010 → 02.2017	N55 B30 A	B	46
520 i	07.2018 → 06.2020	B48 B20 B	B	26	550 i	08.2009 → 06.2012	N63 B44 A	B	80
520 i	07.2018 → 06.2020	B48 B20 B	B	26	550 i	07.2012 → 02.2017	N63 B44 A	B	80
520 i	07.2018 → 06.2020	B48 B20 B	B	26	550 i	07.2012 → 02.2017	N63 B44 B	B	80
520 i	07.2018 → 06.2020	B48 B20 B	B	26	550 i	07.2012 → 02.2017	N63 B44 B	B	80
520 i Mild-Hybrid	07.2020 →	B48 B20 A	AB	31	550 i xDrive	06.2010 → 06.2012	N63 B44 A	B	80
520 i Mild-Hybrid	07.2020 →	B48 B20 A	AB	31	550 i xDrive	07.2012 → 02.2017	N63 B44 B	B	80
523 D XDRIVE	07.2020 →	B47 D20 B	D	64	<b>5 Touring (E34)</b>				
MILD-HYBRID					518 g	02.1996 → 07.1996	M43 B18 (184E2)	AB	56
525 d	07.2017 → 06.2019	B47 D20 B	D	64	518 i	04.1993 → 04.1994	M40 B18 (184E1)	B	35
525 d	07.2017 → 06.2019	B47 D20 B	D	64	518 i	05.1994 → 07.1996	M43 B18 (184E2)	AB	56
530 d	09.2016 → 06.2020	B57 D30 A	D	63	520 i	07.1991 → 07.1996	M50 B20 (206S1)	B	9
530 d Mild-Hybrid	07.2020 →	B57 D30 B	D	62	520 i	07.1991 → 07.1996	M50 B20 (206S2)	B	9
530 d Mild-Hybrid	07.2020 →	B57 D30 B	D	62	530 i	09.1992 → 07.1996	M60 B30 (308S1)	B	39
530 d Mild-Hybrid	07.2020 →	B57 D30 B	D	62	540 i	09.1993 → 07.1996	M60 B40 (408S1)	B	79
xDrive					<b>5 Touring (E39)</b>				
					520 d	02.2000 → 09.2003	M47 D20 (204D1)	D	59



			Pos				Pos	
<b>B</b>	520 i	03.1997 → 08.1998	M52 B20 (206S3) B	<b>10</b>	<b>5 Touring (F11)</b>			
	520 i	03.1997 → 08.1998	M52 B20 (206S3) B	<b>10</b>	518 d	07.2013 → 06.2014	N47 D20 C D <b>61</b>	
	520 i	09.1998 → 08.2001	M52 B20 (206S4) B	<b>10</b>	518 d	07.2013 → 06.2014	N47 D20 C D <b>61</b>	
	520 i	09.1998 → 08.2001	M52 B20 (206S4) B	<b>10</b>	518 d	07.2014 → 02.2017	B47 D20 A D <b>63</b>	
	520 i	09.2000 → 12.2003	M54 B22 (226S1) B	<b>11</b>	518 d	07.2014 → 02.2017	B47 D20 A D <b>63</b>	
	520 i	09.2000 → 12.2003	M54 B22 (226S1) B	<b>11</b>	518 d	07.2014 → 02.2017	B47 D20 A D <b>63</b>	
	523 i	03.1997 → 08.2000	M52 B25 (256S3) B	<b>40</b>	520 d	06.2010 → 06.2014	N47 D20 C D <b>61</b>	
	523 i	09.1998 → 08.2000	M52 B25 (256S4) B	<b>40</b>	520 d	06.2010 → 06.2014	N47 D20 C D <b>61</b>	
	523 i	09.1998 → 08.2000	M52 B25 (256S4) B	<b>40</b>	520 d	06.2010 → 06.2014	N47 D20 C D <b>61</b>	
	525 d	02.2000 → 05.2004	M57 D25 (256D1) D	<b>16</b>	520 d	06.2010 → 02.2017	B47 D20 A D <b>63</b>	
	525 i	09.2000 → 12.2003	M54 B25 (256S5) B	<b>40</b>	520 d	06.2010 → 02.2017	N47 D20 C D <b>61</b>	
	525 i	09.2000 → 05.2004	M54 B25 (256S5) B	<b>40</b>	520 d	07.2014 → 02.2017	B47 D20 A D <b>63</b>	
	528 i	11.1996 → 08.2000	M52 B28 (286S1) B	<b>40</b>	520 d	07.2014 → 02.2017	B47 D20 A D <b>63</b>	
	528 i	11.1996 → 08.2000	M52 B28 (286S2) B	<b>40</b>	520 d	07.2014 → 02.2017	B47 D20 A D <b>63</b>	
	530 d	08.1998 → 09.2000	M57 D30 (306D1) D	<b>59</b>	520 d xDrive	07.2013 → 06.2014	N47 D20 C D <b>61</b>	
	530 d	09.2000 → 05.2004	M57 D30 (306D1) D	<b>59</b>	520 d xDrive	07.2013 → 06.2014	N47 D20 C D <b>61</b>	
	530 i	09.2000 → 12.2003	M54 B30 (306S3) B	<b>40</b>	520 d xDrive	07.2013 → 06.2014	N47 D20 C D <b>61</b>	
	540 i	04.1997 → 12.2003	M62 B44 (448S1) B	<b>87</b>	520 d xDrive	07.2014 → 02.2017	B47 D20 A D <b>63</b>	
	540 i	04.1997 → 12.2003	M62 B44 (448S2) B	<b>87</b>	520 d xDrive	07.2014 → 02.2017	B47 D20 A D <b>63</b>	
	<b>5 Touring (E61)</b>					520 d xDrive	07.2014 → 02.2017	B47 D20 A D <b>63</b>
	520 d	04.2005 → 05.2010	M47 D20 (204D4) D	<b>59</b>	520 d xDrive	07.2014 → 02.2017	B47 D20 A D <b>63</b>	
	520 d	04.2005 → 05.2010	N47 D20 C D	<b>61</b>	520 i	10.2010 → 02.2017	N20 B20 A AB <b>57</b>	
	520 d	09.2005 → 02.2007	M47 D20 (204D4) D	<b>59</b>	520 i	10.2010 → 02.2017	N20 B20 B B <b>46</b>	
	520 d	09.2007 → 05.2010	N47 D20 A D	<b>61</b>	520 i	09.2011 → 02.2017	N20 B20 A AB <b>57</b>	
	520 d	09.2007 → 05.2010	N47 D20 C D	<b>61</b>	520 i	09.2011 → 02.2017	N20 B20 B B <b>46</b>	
	520 i	07.2007 → 08.2010	N43 B20 A B	<b>48</b>	523 i	11.2009 → 08.2011	N52 B25 A B <b>22</b>	
	520 i	09.2007 → 12.2010	N43 B20 A B	<b>48</b>	523 i	11.2009 → 08.2011	N52 B25 AF B <b>22</b>	
	523 i	10.2004 → 02.2007	N52 B25 A B	<b>22</b>	523 i	11.2009 → 08.2011	N52 B25 B B <b>22</b>	
	523 i	10.2004 → 02.2007	N52 B25 B B	<b>22</b>	523 i	11.2009 → 08.2011	N53 B30 A B <b>73</b>	
	523 i	10.2004 → 02.2007	N52 B25 BE B	<b>22</b>	525 d	09.2010 → 08.2011	N57 D30 A D <b>62</b>	
	523 i	01.2007 → 12.2010	N53 B25 A B	<b>22</b>	525 d	09.2011 → 02.2017	N47 D20 D D <b>61</b>	
	523 i	03.2007 → 01.2010	N52 B25 A B	<b>22</b>	525 d	09.2011 → 02.2017	N47 D20 D D <b>61</b>	
	525 d	03.2004 → 03.2007	M57 D25 (256D2) D	<b>16</b>	525 d xDrive	07.2013 → 02.2017	N47 D20 D D <b>61</b>	
	525 d	03.2004 → 03.2007	M57 D25 (256D2) D	<b>16</b>	525 d xDrive	07.2013 → 02.2017	N47 D20 D D <b>61</b>	
	525 d	03.2007 → 05.2010	M57 D30 (306D3) D	<b>60</b>	528 i	11.2009 → 08.2011	N53 B30 A B <b>73</b>	
525 d xDrive	09.2008 → 05.2010	M57 D30 (306D3) D	<b>60</b>	528 i	09.2011 → 02.2017	N20 B20 A AB <b>57</b>		
525 i	06.2004 → 12.2010	M54 B25 (256S5) B	<b>40</b>	528 i xDrive	09.2011 → 02.2017	N20 B20 A AB <b>57</b>		
525 i	03.2005 → 05.2010	N52 B25 A B	<b>22</b>	530 d	06.2010 → 08.2011	N57 D30 A D <b>62</b>		
525 i	03.2005 → 05.2010	N52 B25 A B	<b>22</b>	530 d	09.2011 → 02.2017	N57 D30 A D <b>62</b>		
525 i	03.2005 → 05.2010	N52 B25 B B	<b>22</b>	530 d	09.2011 → 02.2017	N57 D30 A D <b>62</b>		
525 i	03.2005 → 05.2010	N52 B25 BF B	<b>22</b>	530 d xDrive	03.2011 → 02.2017	N57 D30 A D <b>62</b>		
525 i	01.2007 → 12.2010	N53 B30 A B	<b>73</b>	530 d xDrive	03.2011 → 02.2017	N57 D30 A D <b>62</b>		
525 i	01.2007 → 12.2010	N53 B30 A B	<b>73</b>	530 i	03.2010 → 05.2013	N52 B30 A B <b>71</b>		
525 i xDrive	09.2008 → 12.2010	N53 B30 A B	<b>73</b>	530 i	03.2010 → 05.2013	N52 B30 AF B <b>71</b>		
525 xd	09.2007 → 09.2008	M57 D30 (306D3) D	<b>60</b>	530 i	07.2011 → 06.2013	N53 B30 A B <b>73</b>		
525 xi	07.2005 → 12.2010	N52 B25 A B	<b>22</b>	535 d	09.2010 → 08.2011	N57 D30 B D <b>63</b>		
525 xi	01.2007 → 12.2010	N53 B30 A B	<b>73</b>	535 d	09.2011 → 02.2017	N57 D30 B D <b>63</b>		
530 d	03.2004 → 09.2005	M57 D30 (306D2) D	<b>60</b>	535 d xDrive	09.2011 → 02.2017	N57 D30 B D <b>63</b>		
530 d	03.2004 → 05.2010	M57 D30 (306D2) D	<b>60</b>	535 i	06.2010 → 02.2017	N55 B30 A B <b>46</b>		
530 d	03.2004 → 05.2010	M57 D30 (306D3) D	<b>60</b>	535 i	07.2013 → 02.2017	N55 B30 A B <b>46</b>		
530 d	02.2005 → 02.2007	M57 D30 (306D3) D	<b>60</b>	535 i xDrive	09.2011 → 02.2017	N55 B30 A B <b>46</b>		
530 d	02.2007 → 05.2010	M57 D30 (306D3) D	<b>60</b>	535 i xDrive	07.2013 → 02.2017	N55 B30 A B <b>46</b>		
530 d xDrive	09.2007 → 05.2010	M57 D30 (306D3) D	<b>60</b>	550 i	09.2010 → 06.2013	N63 B44 A B <b>80</b>		
530 i	09.2004 → 02.2007	N52 B30 A B	<b>71</b>	550 i	07.2013 → 02.2017	N63 B44 B B <b>80</b>		
530 i	09.2004 → 02.2007	N52 B30 BF B	<b>71</b>	M 550 d xDrive	03.2012 → 02.2017	N57 D30 C D <b>63</b>		
530 i	09.2006 → 03.2010	N52 B30 A B	<b>71</b>	<b>5 Touring (G31)</b>				
530 i	01.2007 → 12.2010	N53 B30 A B	<b>73</b>	518 d	07.2018 → 06.2020	B47 D20 B D <b>64</b>		
530 i xDrive	09.2008 → 05.2010	N53 B30 A B	<b>73</b>	518 d	07.2018 → 06.2020	B47 D20 B D <b>64</b>		
530 xd	02.2005 → 02.2007	M57 D30 (306D3) D	<b>60</b>	518 d Mild-Hybrid	07.2020 →	B47 D20 B D <b>64</b>		
530 xd	03.2007 → 08.2007	M57 D30 (306D3) D	<b>60</b>	518 d Mild-Hybrid	07.2020 →	B47 D20 B D <b>64</b>		
530 xi	04.2005 → 02.2007	N52 B30 A B	<b>71</b>	520 E PLUG-IN-HYBRID	03.2021 →	B48 B20 A AB <b>31</b>		
530 xi	09.2006 → 09.2008	N53 B30 A B	<b>73</b>	520 E PLUG-IN-HYBRID	03.2021 →	B48 B20 A AB <b>31</b>		
530 xi	03.2007 → 05.2010	N52 B30 A B	<b>71</b>	520 d	03.2017 → 10.2019	B47 D20 A D <b>63</b>		
535 d	09.2004 → 12.2010	M57 D30 (306D4) D	<b>60</b>	520 d	03.2017 → 10.2019	B47 D20 A D <b>63</b>		
535 d	01.2007 → 12.2010	M57 D30 (306D5) D	<b>60</b>	520 d	07.2018 → 10.2019	B47 D20 B D <b>64</b>		
535 xi	03.2007 → 05.2010	N54 B30 A B	<b>47</b>	520 d	07.2018 → 10.2019	B47 D20 B D <b>64</b>		
545 i	06.2004 → 12.2010	N62 B44 A B	<b>88</b>	520 d Mild-Hybrid	11.2019 →	B47 D20 B D <b>64</b>		
550 i	07.2005 → 12.2010	N62 B48 A B	<b>91</b>	520 d Mild-Hybrid	11.2019 →	B47 D20 B D <b>64</b>		
550 i	07.2005 → 12.2010	N62 B48 B B	<b>91</b>					

				Pos					Pos
520 d Mild-Hybrid xDrive	11.2019 →	B47 D20 B	D	64	645 Ci	01.2004 → 12.2005	N62 B44 A	B	88
520 d xDrive	07.2017 → 10.2019	B47 D20 A	D	63	650 i	09.2005 → 08.2010	N62 B48 B	B	91
520 d xDrive	07.2017 → 10.2019	B47 D20 A	D	63	6 (E64)				
520 d xDrive	07.2018 → 10.2019	B47 D20 B	D	64	650i 4.8 32V	09.2005 → 09.2007	N62 B48 B	B	91
520 d xDrive	07.2018 → 10.2019	B47 D20 B	D	64	650i 4.8 32V	09.2007 → 07.2010	N62 B48 A	B	91
520 i	07.2017 → 06.2020	B48 B20 A	AB	31	6 Convertible (E64)				
520 i	07.2017 → 06.2020	B48 B20 A	AB	31	630 i	09.2004 → 03.2006	N52 B30 B	B	71
520 i	07.2017 → 06.2020	B48 B20 A	AB	31	630 i	09.2004 → 08.2007	N52 B30 A	B	71
520 i Mild-Hybrid	07.2020 →	B48 B20 A	AB	31	630 i	09.2004 → 08.2007	N52 B30 BF	B	71
520 i Mild-Hybrid	07.2020 →	B48 B20 A	AB	31	630 i	09.2007 → 08.2010	N52 B30 A	B	71
525 d	07.2017 → 06.2019	B47 D20 B	D	64	630 i	09.2007 → 08.2010	N52 B30 B	B	71
525 d	07.2017 → 06.2019	B47 D20 B	D	64	630 i	09.2007 → 08.2010	N52 B30 BF	B	71
530 d	03.2017 → 06.2020	B57 D30 A	D	63	630 i	09.2007 → 08.2010	N53 B30 A	B	73
530 d Mild-Hybrid	07.2020 →	B57 D30 B	D	62	635 d	07.2007 → 07.2010	M57 D30 (306D5)	D	60
530 d Mild-Hybrid	07.2020 →	B57 D30 B	D	62	645 Ci	04.2004 → 08.2005	N62 B44 A	B	88
530 d Mild-Hybrid xDrive	07.2020 →	B57 D30 B	D	62	645 Ci	04.2004 → 12.2005	N62 B44 A	B	88
530 d Mild-Hybrid xDrive	07.2020 →	B57 D30 B	D	62	650 i	09.2005 → 08.2010	N62 B48 B	B	91
530 d Mild-Hybrid xDrive	07.2020 →	B57 D30 B	D	62	6 Convertible (F12)				
530 d xDrive	03.2017 → 06.2020	B57 D30 A	D	63	640 d	09.2011 → 06.2018	N57 D30 B	D	63
530 e Plug-in-Hybrid	11.2020 →	B48 B20 A	AB	31	640 d xDrive	03.2012 → 06.2018	N57 D30 B	D	63
530 e Plug-in-Hybrid	11.2020 →	B48 B20 A	AB	31	640 i	09.2011 → 06.2018	N55 B30 A	B	46
530 e Plug-in-Hybrid	11.2020 →	B48 B20 A	AB	31	640 i xDrive	03.2013 → 06.2018	N55 B30 A	B	46
530 e Plug-in-Hybrid	11.2020 →	B48 B20 A	AB	31	650 i	12.2010 → 06.2012	N63 B44 A	B	80
530 e Plug-in-Hybrid	11.2020 →	B48 B20 A	AB	31	650 i	09.2011 → 12.2012	N63 B44 A	B	80
530 e Plug-in-Hybrid xDrive	11.2020 →	B48 B20 A	AB	31	650 i	07.2012 → 06.2018	N63 B44 A	B	80
530 e Plug-in-Hybrid xDrive	11.2020 →	B48 B20 A	AB	31	650 i	07.2012 → 06.2018	N63 B44 B	B	80
530 e Plug-in-Hybrid xDrive	11.2020 →	B48 B20 A	AB	31	650 i	07.2012 → 06.2018	N63 B44 B	B	80
530 e Plug-in-Hybrid xDrive	11.2020 →	B48 B20 A	AB	31	650 i xDrive	09.2011 → 06.2012	N63 B44 A	B	80
530 e Plug-in-Hybrid xDrive	11.2020 →	B48 B20 A	AB	31	650 i xDrive	09.2011 → 06.2012	N63 B44 A	B	80
530 e Plug-in-Hybrid xDrive	11.2020 →	B48 B20 A	AB	31	650 i xDrive	07.2012 → 06.2018	N63 B44 A	B	80
530 e Plug-in-Hybrid xDrive	11.2020 →	B48 B20 A	AB	31	650 i xDrive	07.2012 → 06.2018	N63 B44 B	B	80
530 i	03.2017 → 06.2020	B48 B20 B	B	26	650 i xDrive	07.2012 → 06.2018	N63 B44 B	B	80
530 i Mild-Hybrid	07.2020 →	B48 B20 B	B	26	6 (E63)				
530 i Mild-Hybrid xDrive	07.2020 →	B48 B20 B	B	26	640 d	09.2011 → 10.2017	N57 D30 B	D	63
530 i xDrive	07.2017 → 06.2020	B48 B20 B	B	26	640 d xDrive	03.2012 → 10.2017	N57 D30 B	D	63
540 d Mild-Hybrid xDrive	07.2020 →	B57 D30 B	D	62	640 i	07.2011 → 10.2017	N55 B30 A	B	46
540 d xDrive	07.2017 → 06.2020	B57 D30 B	D	62	640 i xDrive	03.2013 → 10.2017	N55 B30 A	B	46
540 i xDrive	03.2017 → 06.2020	B58 B30 A	B	26	640 i xDrive	03.2013 → 10.2017	N55 B30 A	B	46
540 i xDrive	03.2017 → 06.2020	B58 B30 A	B	26	650 i	07.2011 → 06.2012	N63 B44 A	B	80
M 550 d xDrive	07.2017 →	B57 D30 C	D	65	650 i	09.2011 → 12.2012	N63 B44 A	B	80
6 (E24)					650 i	07.2012 → 10.2017	N63 B44 B	B	80
628 CSi	09.1979 → 08.1987	M30 B28	B	75	650 i xDrive	09.2011 → 06.2012	N63 B44 A	B	80
630 CS	04.1976 → 08.1979	M30 B30	B	78	650 i xDrive	09.2011 → 02.2015	N63 B44 A	B	80
630 CS	04.1976 → 08.1979	M30 B30	B	78	650 i xDrive	07.2012 → 10.2017	N63 B44 B	B	80
630 CS (S)	04.1976 → 08.1979	M30 B30 V	B	78	650 i xDrive	07.2012 → 10.2017	N63 B44 B	B	80
630 CSi	09.1976 → 12.1978	M30 B30	B	78	6 (Gran Coupe (F06))				
633 CSi	10.1975 → 12.1981	M30 B32	B	78	640 d	03.2012 → 10.2018	N57 D30 B	D	63
633 CSi	09.1977 → 12.1981	M30 B32	B	78	640 d xDrive	03.2013 → 10.2018	N57 D30 B	D	63
633 CSi	10.1979 → 08.1984	M30 B32	B	78	640 i	03.2012 → 10.2018	N55 B30 A	B	46
633 CSi	09.1981 → 12.1984	M30 B32	B	78	640 i xDrive	03.2013 → 10.2018	N55 B30 A	B	46
635 CSi	05.1982 → 06.1987	M30 B35	B	86	650 i	07.2012 → 10.2018	N63 B44 B	B	80
635 CSi	10.1982 → 04.1982	M30 B35	B	92	650 i	07.2013 → 10.2018	N63 B44 B	B	80
635 CSi	10.1984 → 04.1982	M30 B35	B	86	650 i xDrive	07.2012 → 10.2018	N63 B44 B	B	80
635 CSi (CH)	01.1983 → 1985	M30 B32	B	78	650 i xDrive	07.2013 → 10.2018	N63 B44 B	B	80
635 CSi (CH)	01.1983 → 1985	M30 B32 (315/1A)	B	78	6 (Gran Turismo (G32))				
6 (E63)					620 d	07.2018 → 06.2020	B47 D20 B	D	64
630 i	09.2004 → 08.2007	N52 B30 A	B	71	620 d	07.2018 → 06.2020	B47 D20 B	D	64
630 i	09.2004 → 08.2007	N52 B30 BF	B	71	620 d Mild-Hybrid	07.2020 →	B47 D20 B	D	64
630 i	09.2007 → 08.2010	N52 B30 A	B	71	620 d Mild-Hybrid	07.2020 →	B47 D20 B	D	64
630 i	09.2007 → 08.2010	N52 B30 B	B	71	620 d Mild-Hybrid xDrive	07.2020 →	B47 D20 B	D	64
630 i	09.2007 → 08.2010	N52 B30 BF	B	71	620 d xDrive	07.2018 → 06.2020	B47 D20 B	D	64
630 i	09.2007 → 08.2010	N53 B30 A	B	73	620 d xDrive	07.2018 → 06.2020	B47 D20 B	D	64
635 d	07.2007 → 07.2010	M57 D30 (306D5)	D	60	630 d	06.2017 → 06.2020	B57 D30 A	D	63
645 Ci	09.2003 → 08.2005	N62 B44 A	B	88	630 d	06.2017 → 06.2020	B57 D30 A	D	63
					630 d Mild-Hybrid	07.2020 →	B57 D30 B	D	62
					630 d Mild-Hybrid	07.2020 →	B57 D30 B	D	62
					xDrive				

		Pos			Pos		
630 d xDrive	06.2017 → 06.2020	B57 D30 A D	63	730 d	09.2008 → 06.2012	N57 D30 A D	62
630 d xDrive	06.2017 → 06.2020	B57 D30 A D	63	730 d	07.2012 → 05.2015	N57 D30 A D	62
630 d xDrive	06.2017 → 06.2020	B57 D30 A D	63	730 d xDrive	11.2011 → 05.2015	N57 D30 A D	62
630 i	06.2017 → 06.2020	B48 B20 B	26	730 d xDrive	11.2011 → 05.2015	N57 D30 A D	62
630 i	07.2017 → 06.2020	B48 B20 B	26	730 i, Li	09.2009 → 06.2015	N52 B30 A B	71
630 i Mild-Hybrid	07.2020 →	B48 B20 B	26	730 i, Li	09.2009 → 06.2015	N52 B30 AF B	71
640 d Mild-Hybrid xDrive	07.2020 →	B57 D30 B D	62	730 i, Li	09.2009 → 06.2015	N52 B30 BF B	71
640 d xDrive	11.2017 → 06.2020	B57 D30 B D	62	740 d	09.2009 → 06.2012	N57 D30 B D	63
640 i	06.2017 → 06.2019	B58 B30 A B	26	740 d	07.2012 → 06.2015	N57 D30 B D	63
640 i	06.2017 → 06.2019	B58 B30 A B	26	740 d xDrive	09.2010 → 12.2012	N57 D30 B D	63
640 i xDrive	06.2017 → 06.2019	B58 B30 A B	26	740 d xDrive	07.2012 → 06.2015	N57 D30 B D	63
640 i xDrive	06.2017 → 06.2019	B58 B30 A B	26	740 i, Li	09.2008 → 06.2012	N54 B30 A B	47
<b>7 (E23)</b>				740 i, Li	09.2010 → 12.2015	N54 B30 A B	47
725 i	07.1977 → 06.1986	M30 B25 B	75	740 i, Li	07.2012 → 12.2015	N55 B30 A B	46
728	05.1977 → 08.1979	M30 B28 B	75	740 i, Li xDrive	07.2012 → 12.2015	N55 B30 A B	46
728 i	09.1977 → 08.1986	M30 B28 B	75	750 Li	09.2008 → 08.2015	N63 B44 B B	80
730	05.1977 → 08.1979	M30 B30 B	78	750 d xDrive	07.2012 → 12.2015	N57 D30 C D	63
730 3.0 (S)	04.1976 → 08.1979	M30 B30 V B	78	750 i	09.2012 → 06.2015	N63 B44 B B	80
732 i	09.1979 → 08.1986	M30 B32 B	78	750 i, Li	09.2008 → 06.2012	N63 B44 A B	80
732i 3.2 (USA)	05.1977 → 1983	M30 B32 LU B	78	750 i, Li	07.2012 → 06.2015	N63 B44 B B	80
733 i	05.1977 → 08.1986	M30 B32 B	78	750 i, Li xDrive	09.2009 → 06.2012	N63 B44 A B	80
733 i	09.1977 → 12.1981	M30 B32 B	78	750 i, Li xDrive	07.2012 → 06.2015	N63 B44 B B	80
733 i	09.1979 → 12.1981	M30 B32 B	78	ActiveHybrid 7	04.2010 → 06.2012	N63 B44 A B	80
733 i	09.1981 → 12.1984	M30 B32 B	78	ActiveHybrid 7	04.2010 → 06.2012	N63 B44 A B	80
733i 3.2 (USA)	05.1977 → 08.1979	M30 B32 LU B	78	ActiveHybrid 7	08.2012 → 06.2015	N55 B30 A B	46
<b>7 (E32)</b>				ActiveHybrid 7	08.2012 → 06.2015	N55 B30 A B	46
730 i,iL	03.1985 → 01.1989	M30 B30 (306EA) B	78	<b>7 (G11, G12)</b>			
730 i,iL	03.1987 → 03.1994	M30 B30 (306KA) B	78	725 d, Ld	07.2016 → 02.2019	B47 D20 B D	64
730 i,iL V8	04.1992 → 09.1994	M60 B30 (308S1) B	39	725 d, Ld	07.2016 → 02.2019	B47 D20 B D	64
735 i,iL	07.1986 → 01.1989	M30 B35 B	86	730 d	07.2015 → 06.2020	B57 D30 A D	63
		(Motronic,9.		730 d	09.2015 → 06.2020	B57 D30 A D	63
740 i,iL V8	05.1992 → 03.1994	M60 B40 (408S1) B	79	730 d Mild-Hybrid xDrive	07.2020 →	B57 D30 B D	62
750 i,iL V12	09.1987 → 09.1994	M70 B50 (5012A) B	37	730 d xDrive	09.2015 → 06.2020	B57 D30 A D	63
<b>7 (E38)</b>				730 d, Ld Mild-Hybrid	07.2020 →	B57 D30 B D	62
728 i, iL	08.1995 → 11.2001	M52 B28 (286S1) B	40	730 d, Ld Mild-Hybrid xDrive	07.2020 →	B57 D30 B D	62
728 i, iL	08.1995 → 11.2001	M52 B28 (286S2) B	40	730 d, Ld Mild-Hybrid xDrive	07.2020 →	B57 D30 B D	62
728i X	11.1995 → 09.2001	M52 B28 (286S1) B	40	730 d, Ld Mild-Hybrid xDrive	07.2020 →	B57 D30 B D	62
730 d	08.1998 → 04.2000	M57 D30 (306D1) D	59	730 d, Ld xDrive	09.2015 → 06.2020	B57 D30 A D	63
730 d	04.2000 → 11.2001	M57 D30 (306D1) D	59	730 d, Ld xDrive	09.2015 → 06.2020	B57 D30 A D	63
730 i, iL	03.1994 → 02.1996	M60 B30 (308S1) B	39	730 i	11.2015 →	B48 B20 B B	26
730 i, iL	10.1994 → 11.2001	M60 B30 (308S1) B	39	730 i, Li	11.2015 → 02.2019	B48 B20 B B	26
735 i, iL	03.1996 → 08.1998	M62 B35 (358S1) B	39	730 i, Li	03.2019 →	B48 B20 B B	26
735 i, iL	09.1998 → 07.2001	M62 B35 (358S2) B	39	740 Le xDrive	07.2016 → 02.2019	B48 B20 B B	26
735iL 3.5 32V	03.1996 → 09.2001	M62 B35 TU B	39	740 Le xDrive	07.2016 → 02.2019	B48 B20 B B	26
740 d	05.1999 → 11.2001	M67 D39 (398D1) D	59	740 Li xDrive	03.2016 → 02.2019	B58 B30 A B	26
740 i, iL	03.1994 → 02.1996	M60 B40 (408S1) B	79	740 d, Ld Mild-Hybrid xDrive	07.2020 →	B57 D30 B D	62
740 i, iL	02.1996 → 08.1998	M62 B44 (448S1) B	87	740 d, Ld xDrive	11.2015 → 06.2020	B57 D30 B D	62
740 i, iL	09.1998 → 07.2001	M62 B44 (448S2) B	87	740 e, Le	07.2016 → 02.2019	B48 B20 B B	26
750 i, iL	11.1994 → 08.1998	M73 B54 (54121) B	69	740 e, Le	07.2016 → 02.2019	B48 B20 B B	26
750 i, iL	09.1998 → 07.2001	M73 B54 (54122) B	69	740 i, Li	07.2015 → 02.2019	B58 B30 A B	26
750 i, iL	09.1998 → 07.2001	M73 B54 (54122) B	69	750 d, Ld xDrive	07.2016 →	B57 D30 C D	65
<b>7 (E65, E66, E67)</b>				750 i, Li	11.2015 → 02.2019	N63 B44 C B	82
730 Ld	07.2005 → 08.2008	M57 D30 (306D3) D	60	750 i, Li xDrive	09.2015 → 02.2019	N63 B44 C B	82
730 d	06.2002 → 02.2005	M57 D30 (306D2) D	60	750 i, Li xDrive	03.2019 →	N63 B44 D B	83
730 d	09.2002 → 08.2003	M57 D30 (306D2) D	60	<b>8 (E31)</b>			
730 d	09.2003 → 08.2008	M57 D30 (306D2) D	60	830 Ci	08.1992 → 12.1999	M60 B30 (308S1) B	39
730 d	09.2003 → 08.2008	M57 D30 (306D3) D	60	840 Ci	03.1996 → 06.1999	M62 B44 (448S1) B	87
730 i, Li	03.2003 → 07.2008	M54 B30 (306S3) B	40	840 i	03.1993 → 02.1996	M60 B40 (408S1) B	79
730 i, Li	03.2005 → 07.2008	N52 B30 A B	71	850 CSi	11.1992 → 12.1996	S70 B56 (56121) B	76
730 i, Li	03.2005 → 08.2008	N52 B30 A B	71	850 CSi	09.1993 → 12.1995	S70 B56 (56121) B	76
730 i, Li	03.2005 → 08.2008	N52 B30 BF B	71	850 Ci	09.1994 → 12.1999	M73 B54 (54121) B	69
740 d	10.2002 → 02.2005	M67 D39 (398D1) D	59	850 i,Ci	01.1990 → 08.1994	M70 B50 (5012A) B	37
745 i	11.2001 → 12.2003	N62 B44 A B	88	<b>8 Convertible (G14, F91)</b>			
745 i	09.2003 → 12.2005	N62 B44 A B	88	840 d Mild-Hybrid xDrive	11.2020 →	B57 D30 B D	62
745 i, Li	07.2001 → 03.2005	N62 B44 A B	88	840 d xDrive	11.2018 → 10.2020	B57 D30 B D	62
750 i, Li	03.2005 → 08.2008	N62 B48 B B	91	M 850 i xDrive	11.2018 →	N63 B44 D B	83
<b>7 (F01, F02, F03, F04)</b>							
730 d	02.2008 → 05.2015	N57 D30 A D	62				



						Pos							Pos	
<b>8 Coupe (G15, F92)</b>							<b>xDrive 20 i</b>							
840 d Mild-Hybrid	11.2020 →	B57 D30 B	D	<b>62</b>			11.2020 →					B48 A20 A	AB	<b>30</b>
xDrive							<b>xDrive 25 d</b>							
840 d xDrive	07.2018 → 10.2020	B57 D30 B	D	<b>62</b>			11.2014 →					B47 C20 B	D	<b>64</b>
M 850 i xDrive	10.2018 →	N63 B44 D	B	<b>83</b>			03.2020 →					B38 A15 A	B	<b>25</b>
<b>8 Gran Coupe (G16, F93)</b>							<b>Plug-in-Hybrid</b>							
840 d Mild-Hybrid	11.2020 →	B57 D30 B	D	<b>62</b>			03.2020 →					B38 A15 A	B	<b>25</b>
xDrive							<b>xDrive 25 e</b>							
840 d xDrive	07.2019 → 10.2020	B57 D30 B	D	<b>62</b>			03.2020 →					B38 A15 A	B	<b>25</b>
M 850 i xDrive	07.2019 →	N63 B44 D	B	<b>83</b>			<b>Plug-in-Hybrid</b>							
<b>X1 (E84)</b>							<b>xDrive 25 i</b>							
28i 2.0 16V	10.2009 →	N20 B20	B	<b>46</b>			07.2015 →					B48 A20 B	AB	<b>30</b>
28i 2.0 16V	10.2009 →	N20 B20 A	AB	<b>57</b>			07.2018 → 06.2019					B46 A20 B	B	<b>26</b>
35i 3.0 24V	01.2012 →	N55 B30 A	B	<b>46</b>			03.2016 → 01.2018					B48 A20 B	AB	<b>30</b>
sDrive 16 d	04.2012 → 06.2015	N47 D20 C	D	<b>61</b>			<b>X2 (F39)</b>							
sDrive 18 d	03.2009 → 06.2015	N47 D20 C	D	<b>61</b>			<b>sDrive 16 d</b>							
sDrive 18 d	12.2009 → 06.2015	N47 D20 C	D	<b>61</b>			11.2018 →					B37 C15 A	D	<b>63</b>
sDrive 18 i	03.2010 → 06.2015	N46 B20 B	B	<b>42</b>			03.2018 →					B47 C20 A	D	<b>63</b>
sDrive 18 i	03.2010 → 06.2015	N46 B20 B	B	<b>42</b>			03.2018 →					B47 C20 A	D	<b>63</b>
sDrive 18 i	03.2010 → 06.2015	N46 B20 BD	B	<b>42</b>			03.2018 →					B47 C20 A	D	<b>63</b>
sDrive 18 i	03.2010 → 06.2015	N46 B20 BD	B	<b>42</b>			03.2018 →					B47 C20 B	D	<b>64</b>
sDrive 18 i	03.2010 → 06.2015	N46 B20 C	B	<b>45</b>			03.2018 →					B47 C20 B	D	<b>64</b>
sDrive 18 i	03.2010 → 06.2015	N46 B20 CC	B	<b>42</b>			03.2018 →					B47 C20 B	D	<b>64</b>
sDrive 18 i	03.2010 → 06.2015	N46 B20 CD	B	<b>42</b>			03.2018 →					B47 C20 B	D	<b>64</b>
sDrive 18 i	03.2010 → 06.2015	N46 B20 E	B	<b>42</b>			03.2018 →					B47 C20 B	D	<b>64</b>
sDrive 20 d	10.2009 → 06.2015	N47 D20 C	D	<b>61</b>			03.2018 →					B47 C20 B	D	<b>64</b>
sDrive 20 d	03.2010 → 06.2015	N47 D20 C	D	<b>61</b>			03.2018 →					B47 C20 B	D	<b>64</b>
sDrive 20 d	07.2012 → 06.2015	N47 D20 C	D	<b>61</b>			03.2018 →					B47 C20 B	D	<b>64</b>
sDrive 20 i	09.2011 → 06.2015	N20 B20 A	AB	<b>57</b>			03.2018 →					B47 C20 B	D	<b>64</b>
sDrive 20 i Flex	08.2014 → 06.2015	N20 B20 A	AB	<b>57</b>			03.2018 →					B47 C20 B	D	<b>64</b>
sDrive 28 i	09.2012 → 06.2015	N20 B20 A	AB	<b>57</b>			11.2017 →					B48 A20 A	AB	<b>30</b>
xDrive 18 d	03.2009 → 06.2015	N47 D20 C	D	<b>61</b>			11.2020 →					B48 A20 A	AB	<b>30</b>
xDrive 18 d	10.2009 → 06.2015	N47 D20 C	D	<b>61</b>			11.2020 →					B48 A20 A	AB	<b>30</b>
xDrive 20 d	09.2009 → 06.2012	N47 D20 C	D	<b>61</b>			11.2017 →					B47 C20 A	D	<b>63</b>
xDrive 20 d	03.2010 → 06.2015	N47 D20 C	D	<b>61</b>			11.2017 →					B47 C20 A	D	<b>63</b>
xDrive 20 d	07.2012 → 06.2015	N47 D20 C	D	<b>61</b>			11.2017 →					B47 C20 A	D	<b>63</b>
xDrive 20 i	09.2011 → 06.2015	N20 B20 A	AB	<b>57</b>			11.2020 →					B48 A20 A	AB	<b>30</b>
xDrive 23 d	10.2009 → 06.2015	N47 D20 D	D	<b>61</b>			11.2020 →					B48 A20 A	AB	<b>30</b>
xDrive 25 d	10.2009 → 06.2015	N47 D20 D	D	<b>61</b>			11.2017 →					B47 C20 A	D	<b>63</b>
xDrive 25 i	03.2010 → 08.2011	N52 B30 A	B	<b>71</b>			11.2017 →					B47 C20 B	D	<b>64</b>
xDrive 28 i	09.2009 → 08.2011	N52 B30 A	B	<b>71</b>			11.2017 →					B47 C20 B	D	<b>64</b>
xDrive 28 i	03.2010 → 06.2011	N52 B30 A	B	<b>71</b>			11.2017 →					B47 C20 B	D	<b>64</b>
xDrive 28 i	03.2011 → 06.2015	N20 B20 A	AB	<b>57</b>			11.2017 →					B47 C20 B	D	<b>64</b>
xDrive 28 i Flex	04.2011 → 06.2015	N20 B20 A	AB	<b>57</b>			11.2017 →					B47 C20 B	D	<b>64</b>
xDrive 35 i	03.2011 → 06.2015	N55 B30 A	B	<b>46</b>			11.2017 →					B47 C20 B	D	<b>64</b>
<b>X1 (F48)</b>							<b>xDrive 20 i</b>							
sDrive 16 d	11.2014 →	B37 C15 A	D	<b>63</b>			03.2018 → 10.2020					B48 A20 A	AB	<b>30</b>
sDrive 18 d	07.2015 →	B47 C20 A	D	<b>63</b>			11.2020 →					B48 A20 A	AB	<b>30</b>
sDrive 18 d	07.2015 →	B47 C20 A	D	<b>63</b>			11.2020 →					B48 A20 A	AB	<b>30</b>
sDrive 18 d	03.2018 →	B47 C20 B	D	<b>64</b>			11.2020 →					B48 A20 A	AB	<b>30</b>
sDrive 18 i	11.2015 → 02.2018	B38 A15 A	B	<b>25</b>			11.2017 →					B48 A20 A	AB	<b>30</b>
sDrive 18 i	07.2017 →	B38 A15 A	B	<b>25</b>			11.2017 →					B48 A20 A	AB	<b>30</b>
sDrive 20 d	11.2015 →	B47 C20 A	D	<b>63</b>			11.2017 →					B48 A20 A	AB	<b>30</b>
sDrive 20 d	11.2015 →	B47 C20 A	D	<b>63</b>			11.2017 →					B48 A20 A	AB	<b>30</b>
sDrive 20 d	11.2017 →	B47 C20 B	D	<b>64</b>			11.2017 →					B48 A20 A	AB	<b>30</b>
sDrive 20 d	11.2017 →	B47 C20 B	D	<b>64</b>			11.2017 →					B48 A20 A	AB	<b>30</b>
sDrive 20 i	07.2015 →	B48 A20 A	AB	<b>30</b>			11.2017 →					B48 A20 A	AB	<b>30</b>
sDrive 20 i	11.2020 →	B48 A20 A	AB	<b>30</b>			11.2017 →					B48 A20 A	AB	<b>30</b>
sDrive 20 i ActiveFlex	07.2015 → 02.2018	B48 A20 A	AB	<b>30</b>			11.2017 →					B48 A20 A	AB	<b>30</b>
sDrive 28 i	11.2014 →	B46 A20 B	B	<b>26</b>			11.2017 →					B48 A20 A	AB	<b>30</b>
xDrive 18 d	11.2014 →	B47 C20 A	D	<b>63</b>			11.2017 →					B48 A20 A	AB	<b>30</b>
xDrive 18 d	11.2014 →	B47 C20 A	D	<b>63</b>			11.2017 →					B48 A20 A	AB	<b>30</b>
xDrive 18 d	03.2018 →	B47 C20 B	D	<b>64</b>			11.2017 →					B48 A20 A	AB	<b>30</b>
xDrive 20 d	07.2015 →	B47 C20 A	D	<b>63</b>			11.2017 →					B48 A20 A	AB	<b>30</b>
xDrive 20 d	07.2015 →	B47 C20 A	D	<b>63</b>			11.2017 →					B48 A20 A	AB	<b>30</b>
xDrive 20 d	11.2017 →	B47 C20 B	D	<b>64</b>			11.2017 →					B48 A20 A	AB	<b>30</b>
xDrive 20 d	11.2017 →	B47 C20 B	D	<b>64</b>			11.2017 →					B48 A20 A	AB	<b>30</b>
xDrive 20 i	07.2015 → 11.2015	B48 A20 A	AB	<b>30</b>			11.2017 →					B48 A20 A	AB	<b>30</b>
xDrive 20 i	07.2015 → 11.2015	B48 A20 B	AB	<b>30</b>			11.2017 →					B48 A20 A	AB	<b>30</b>
<b>X3 (E83)</b>							<b>2.0 d</b>							
							09.2004 → 08.2007					M47 D20 (204D4)	D	<b>59</b>
							07.2005 → 08.2008					N46 B20 B	B	<b>42</b>
							09.2007 → 08.2008					N47 D20 A	D	<b>61</b>
							01.2004 → 12.2006					M54 B25 (256S5)	B	<b>40</b>
							03.2004 → 07.2006					M54 B25 (256S5)	B	<b>40</b>
							08.2006 → 08.2008					N52 B25 A	B	<b>22</b>
							08.2006 → 08.2008					N52 B25 AF	B	<b>22</b>
							08.2006 → 08.2008					N52 B25 BF	B	<b>22</b>
							08.2006 → 08.2008					N52 B25 A	B	<b>22</b>
							08.2006 → 08.2008					N52 B25 AF	B	<b>22</b>
							08.2006 → 08.2008					N52 B25 BF	B	<b>22</b>
							08.2006 → 08.2008					N52 B25 A	B	<b>22</b>
							08.2006 → 08.2008					N52 B25 AF	B	<b>22</b>
							08.2006 → 08.2008					N52 B25 BF	B	<b>22</b>
							08.2006 → 08.2008					N52 B25 A	B	<b>22</b>
							08.2006 → 08.2008					N52 B25 AF	B	<b>22</b>
							08.2006 → 08.2008					N52 B25 BF	B	<b>22</b>
							08.2006 → 08.2008					N52 B25 A	B	<b>22</b>
							08.2006 → 08.2008					N52 B25 AF	B	<b>22</b>
							08.2006 → 08.2008					N52 B25 BF	B	<b>22</b>
							08.2006 → 08.2008					N52 B25 A	B	<b>22</b>
							08.2006 → 08.2008					N52 B25 AF	B	<b>22</b>
							08.2006 → 08.2008					N52 B25 BF	B	<b>22</b>
							08.2006 → 08.2008					N52 B25 A	B	<b>22</b>
							08.2006 → 08.2008					N52 B25 AF	B	<b>22</b>
							08.2006 → 08.2008					N52 B25 BF	B	<b>22</b>
							08.2006 → 08.2008					N52 B25 A	B	<b>22</b>
							08.2006 → 08.2008					N52 B25 AF	B	<b>22</b>
							08.2006 → 08.2008					N52 B25 BF	B	<b>22</b>
							08.2006 → 08.2008					N52 B25 A	B	<b>22</b>
							08.2006 → 08.2008					N52 B25 AF	B	<b>22</b>
							08.2006 → 08.2008					N52 B25 BF	B	<b>22</b>
							08.2006 → 08.2008					N52 B25 A	B	<b>22</b>
							08.2006 → 08.2008					N52 B25 AF	B	<b>22</b>
							08.2006 → 08.2008					N52 B25 BF	B	<b>22</b>
							08.2006 → 08.2008					N52 B25 A	B	<b>22</b>
							08.2006 → 08.2008					N52 B25 AF	B	<b>22</b>
							08.2006 → 08.2008					N52 B25 BF	B	<b>22</b>
							08.2006 → 08.2008					N52 B25 A	B	<b>22</b>
							08.2006 → 08.2008					N52 B25 AF	B	<b>22</b>
							08.2006 → 08.2008					N52 B25 BF	B	<b>22</b>
							08.2006 → 08.2008					N52 B25 A	B	<b>22</b>
							08.2006 → 08.2008					N52 B25 AF	B	<b>22</b>
							08.2006 → 08.2008					N52 B25 BF	B	<b>22</b>
							08.2006 → 08.2008					N52 B25 A	B	<b>22</b>
							08.2006 → 08.2008					N52 B25 AF	B	<b>22</b>
							08.2006 → 08.2008					N52 B25 BF	B	<b>22</b>



				Pos					Pos	
<b>B</b>	xDrive 25 i	09.2008 → 08.2010	N52 B25 BF	B	22	M 40 i	12.2015 → 03.2018	N55 B30 A	B	46
	xDrive 25 i	09.2008 → 08.2010	N52 B25 BF	B	22	xDrive 20 d	04.2014 → 03.2018	B47 D20 A	D	63
	xDrive 30 d	09.2008 → 08.2010	M57 D30 (306D3)	D	60	xDrive 20 d	04.2014 → 03.2018	B47 D20 A	D	63
	xDrive 30 d	09.2008 → 08.2010	M57 D30 (306D3)	D	60	xDrive 20 i	04.2014 → 03.2018	N20 B20 A	AB	57
	xDrive 30 i	08.2006 → 08.2010	N52 B30 A	B	71	xDrive 28 i	04.2014 → 03.2018	N20 B20 A	AB	57
	xDrive 30 i	09.2008 → 08.2010	N52 B30 A	B	71	xDrive 28 i	04.2014 → 03.2018	N20 B20 A	AB	57
	xDrive 30 i	09.2008 → 08.2010	N52 B30 A	B	71	xDrive 30 d	04.2014 → 03.2018	N57 D30 A	D	62
	xDrive 30 i	09.2008 → 08.2010	N52 B30 BF	B	71	xDrive 30 d	04.2014 → 03.2018	N57 D30 A	D	62
	xDrive 35 d	09.2008 → 08.2011	M57 D30 (306D5)	D	60	xDrive 30 d	04.2014 → 03.2018	N57 D30 A	D	62
	<b>X3 (F25)</b>					xDrive 30 d	04.2014 → 03.2018	N57 D30 A	D	62
	sDrive 18 d	10.2012 → 03.2014	N47 D20 C	D	61	xDrive 30 d	04.2015 → 03.2018	N57 D30 A	D	62
	sDrive 18 d	10.2012 → 03.2014	N47 D20 C	D	61	xDrive 35 d	04.2014 → 03.2018	N57 D30 B	D	63
	sDrive 18 d	04.2014 → 08.2017	B47 D20 A	D	63	xDrive 35 i	04.2014 → 03.2018	N55 B30 A	B	46
	sDrive 20 i	04.2014 → 08.2017	N20 B20 A	AB	57	xDrive 35 i	01.2015 → 03.2018	N55 B30 A	B	46
	sDrive 28 i	04.2014 → 08.2017	N20 B20 A	AB	57	<b>X4 (G02, F98)</b>				
	xDrive 20 d	09.2010 → 03.2014	N47 D20 C	D	61	M40 d Mild-Hybrid	07.2020 →	B57 D30 B	D	62
	xDrive 20 d	09.2010 → 03.2014	N47 D20 C	D	61	xDrive				
	xDrive 20 d	04.2014 → 08.2017	B47 D20 A	D	63	M40 d xDrive	04.2018 → 06.2020	B57 D30 B	D	62
	xDrive 20 i	10.2011 → 08.2017	N20 B20 A	AB	57	M40 i xDrive	04.2018 → 08.2019	B58 B30 A	B	26
	xDrive 28 d	04.2014 → 12.2016	N47 D20 C	D	61	M40 i xDrive	04.2018 → 08.2019	B58 B30 A	B	26
	xDrive 28 i	01.2011 → 10.2012	N52 B30 A	B	71	xDrive 20 d	04.2018 → 03.2020	B47 D20 A	D	63
	xDrive 28 i	01.2011 → 10.2012	N52 B30 AF	B	71	xDrive 20 d	04.2018 → 03.2020	B47 D20 A	D	63
xDrive 28 i	01.2011 → 10.2012	N52 B30 BF	B	71	xDrive 20 d	04.2018 → 03.2020	B47 D20 B	D	64	
xDrive 28 i	04.2012 → 08.2017	N20 B20 A	AB	57	xDrive 20 d	04.2018 → 03.2020	B47 D20 B	D	64	
xDrive 30 d	04.2011 → 05.2016	N57 D30 A	D	62	xDrive 20 d Mild-Hybrid	04.2020 →	B47 D20 B	D	64	
xDrive 30 d	04.2011 → 08.2017	N57 D30 A	D	62	xDrive 20 d Mild-Hybrid	04.2020 →	B47 D20 B	D	64	
xDrive 30 d	04.2011 → 08.2017	N57 D30 A	D	62	xDrive 20 i	04.2018 →	B48 B20 A	AB	31	
xDrive 30 d	06.2011 → 08.2017	N57 D30 A	D	62	xDrive 25 d	04.2018 →	B47 D20 B	D	64	
xDrive 30 d	06.2016 → 08.2017	N57 D30 A	D	62	xDrive 25 d	04.2018 →	B47 D20 B	D	64	
xDrive 35 d	10.2011 → 08.2017	N57 D30 B	D	63	xDrive 30 d	04.2018 → 06.2020	B57 D30 A	D	63	
xDrive 35 i	09.2010 → 08.2017	N55 B30 A	B	46	xDrive 30 d	09.2018 → 06.2020	B57 D30 A	D	63	
xDrive18d	10.2012 →	N47 D20 C	D	61	xDrive 30 d Mild-Hybrid	07.2020 →	B57 D30 B	D	62	
<b>X3 (G01, F97)</b>					xDrive 30 d Mild-Hybrid	07.2020 →	B57 D30 B	D	62	
sDrive 18 d	04.2018 → 06.2020	B47 D20 A	D	63	xDrive 30 i	04.2018 →	B48 B20 B	B	26	
sDrive 18 d	04.2018 → 06.2020	B47 D20 A	D	63	xDrive 30 i	04.2018 →	B48 B20 B	B	26	
sDrive 18 d	05.2019 → 06.2020	B47 D20 B	D	64	<b>X5 (E53)</b>					
sDrive 18 d	05.2019 → 06.2020	B47 D20 B	D	64	3.0 d	04.2001 → 09.2003	M57 D30 (306D1)	D	59	
sDrive 18 d Mild-Hybrid	07.2020 →	B47 D20 B	D	64	3.0 d	10.2003 → 09.2006	M57 D30 (306D2)	D	60	
sDrive 18 d Mild-Hybrid	07.2020 →	B47 D20 B	D	64	3.0 d	10.2003 → 09.2006	M57 D30 (306D2)	D	60	
sDrive 20 i	12.2017 →	B48 B20 A	AB	31	3.0 i	04.2000 → 10.2006	M54 B30 (306S3)	B	40	
xDrive 20 d	08.2017 → 04.2019	B47 D20 A	D	63	3.0 i	06.2000 → 12.2006	M54 B30 (306S3)	B	40	
xDrive 20 d	08.2017 → 04.2019	B47 D20 A	D	63	4.4 i	01.2000 → 09.2003	M62 B44 (448S2)	B	87	
xDrive 20 d	05.2019 → 03.2020	B47 D20 B	D	64	4.4 i	10.2003 → 10.2006	N62 B44 A	B	88	
xDrive 20 d	05.2019 → 03.2020	B47 D20 B	D	64	4.6 is	10.2001 → 09.2003	M62 B46 (468S1)	B	90	
xDrive 20 d Mild-Hybrid	04.2020 →	B47 D20 B	D	64	4.8 is	04.2004 → 09.2006	N62 B48 A	B	91	
xDrive 20 d Mild-Hybrid	04.2020 →	B47 D20 B	D	64	<b>X5 (E70)</b>					
xDrive 20 i	12.2017 →	B48 B20 A	AB	31	3.0 3.0d	02.2007 → 09.2008	M57 D30 (306D3)	D	60	
xDrive 20 i	09.2018 →	B48 B20 B	B	26	3.0 d	12.2006 → 09.2008	M57 D30 (306D3)	D	60	
xDrive 25 d	04.2018 →	B47 D20 B	D	64	3.0 sd	10.2007 → 09.2008	M57 D30 (306D5)	D	60	
xDrive 25 d	04.2018 →	B47 D20 B	D	64	3.0 si	10.2006 → 09.2008	N52 B30 A	B	71	
xDrive 30 e	12.2019 →	B48 B20 A	AB	31	3.0 si	10.2006 → 09.2008	N52 B30 AF	B	71	
Plug-in-Hybrid					3.0 si	10.2006 → 09.2008	N52 B30 BF	B	71	
xDrive 30 e	12.2019 →	B48 B20 A	AB	31	35d 3.0	05.2008 → 05.2010	M57 D30 N2	D	60	
Plug-in-Hybrid					4.8 i xDrive	10.2006 → 09.2008	N62 B48 B	B	91	
xDrive 30 e	12.2019 →	B48 B20 A	AB	31	M	07.2009 → 07.2013	S63 B44 A	B	81	
Plug-in-Hybrid					M	09.2009 → 06.2013	S63 B44 A	B	81	
xDrive 30 e	12.2019 →	B48 B20 A	AB	31	M 50 d	08.2011 → 06.2013	N57 D30 C	D	63	
Plug-in-Hybrid					xDrive 30 d	10.2008 → 03.2010	M57 D30 (306D3)	D	60	
xDrive 30 i	08.2017 →	B48 B20 B	B	26	xDrive 30 d	10.2008 → 03.2010	M57 D30 (306D3)	D	60	
xDrive 30 i	08.2017 →	B48 B20 B	B	26	xDrive 30 d	04.2010 → 07.2013	N57 D30 A	D	62	
xDrive 30d	08.2017 → 06.2020	B57 D30 A	D	63	xDrive 30 d	04.2010 → 07.2013	N57 D30 A	D	62	
xDrive 30d	12.2017 → 06.2020	B57 D30 A	D	63	xDrive 30 i	02.2007 → 12.2012	N52 B30 A	B	71	
xDrive 30d Mild-Hybrid	07.2020 →	B57 D30 B	D	62	xDrive 30 i	09.2008 → 12.2010	N52 B30 A	B	71	
xDrive 30d Mild-Hybrid	07.2020 →	B57 D30 B	D	62	xDrive 30 i	10.2008 → 03.2010	N52 B30 A	B	71	
xDrive M40 d	08.2018 → 06.2020	B57 D30 B	D	62	xDrive 35 d	10.2008 → 07.2013	M57 D30 (306D5)	D	60	
xDrive M40 d	08.2018 →	B57 D30 B	D	62	xDrive 35 i	04.2010 → 07.2013	N55 B30 A	B	46	
Mild-Hybrid					xDrive 35 i	02.2012 → 06.2013	N55 B30 A	B	46	
xDrive M40 i	08.2017 → 08.2019	B58 B30 A	B	26	xDrive 40 d	09.2010 → 06.2013	N57 D30 B	D	63	
xDrive M40 i	09.2018 → 08.2019	B58 B30 A	B	26	xDrive 40 i	01.2012 → 06.2013	N55 B30 A	B	46	
<b>X4 (F26)</b>										

				Pos					Pos
xDrive 48 i	10.2008 → 03.2010	N62 B48 B	B	91	xDrive 35 i	08.2014 → 07.2019	N55 B30 A	B	46
xDrive 50 i	09.2009 → 06.2013	N63 B44 A	B	80	xDrive 35 i	08.2014 → 07.2019	N55 B30 A	B	46
xDrive 50 i	04.2010 → 07.2013	N63 B44 A	B	80	xDrive 40 d	12.2014 → 07.2019	N57 D30 B	D	63
<b>X5 (F15, F85)</b>					<b>X6 (G06, F96)</b>				
M 50 d	12.2013 → 07.2018	N57 D30 C	D	63	M50 i xDrive	08.2019 →	N63 B44 D	B	83
sDrive 25 d	12.2013 → 07.2015	N47 D20 D	D	61	xDrive 30 d	08.2019 → 07.2020	B57 D30 A	D	63
sDrive 25 d	12.2013 → 07.2015	N47 D20 D	D	61	xDrive 30 d	08.2019 → 07.2020	B57 D30 A	D	63
sDrive 25 d	08.2015 → 07.2018	B47 D20 B	D	64	xDrive 30 d	08.2019 → 07.2020	B57 D30 A	D	63
sDrive 35 i	08.2013 → 07.2018	N55 B30 A	B	46	xDrive 30 d	08.2019 → 07.2020	B57 D30 A	D	63
xDrive 25 d	12.2013 → 07.2015	N47 D20 D	D	61	xDrive 30 d Mild-Hybrid	08.2020 →	B57 D30 B	D	62
xDrive 25 d	12.2013 → 07.2015	N47 D20 D	D	61	xDrive 30 d Mild-Hybrid	08.2020 →	B57 D30 B	D	62
xDrive 25 d	04.2014 → 07.2018	N57 D30 A	D	62	xDrive 30 d Mild-Hybrid	08.2020 →	B57 D30 B	D	62
xDrive 25 d	08.2015 → 07.2018	B47 D20 B	D	64	xDrive 30 i	11.2019 →	B48 B20 B	B	26
xDrive 28 i	06.2015 → 07.2018	N20 B20 A	AB	57	xDrive 40 d Mild-Hybrid	05.2020 →	B57 D30 B	D	62
xDrive 30 d	08.2013 → 07.2018	N57 D30 A	D	62	xDrive M 50 d	08.2019 →	B57 D30 C	D	65
xDrive 30 d	08.2013 → 07.2018	N57 D30 A	D	62	<b>X7 (G07)</b>				
xDrive 30 d	08.2013 → 07.2018	N57 D30 A	D	62	xDrive 30 d	03.2019 → 08.2020	B57 D30 A	D	63
xDrive 30 d	12.2013 → 07.2018	N57 D30 A	D	62	xDrive 30 d	03.2019 →	B57 D30 A	D	63
xDrive 35 i	12.2013 → 07.2018	N55 B30 A	B	46	xDrive 30 d	03.2019 →	B57 D30 A	D	63
xDrive 35 i	12.2013 → 07.2018	N55 B30 A	B	46	xDrive 40 d Mild-Hybrid	03.2019 →	B57 D30 B	D	62
xDrive 40 d	12.2013 → 07.2018	N57 D30 B	D	63	xDrive 40 d Mild-Hybrid	03.2019 →	B57 D30 B	D	62
xDrive 40e	08.2015 → 07.2018	N20 B20 A	AB	57	xDrive 50 i	03.2019 →	N63 B44 D	B	83
xDrive 40e	08.2015 → 07.2018	N20 B20 A	AB	57	xDrive M 50 d	03.2019 →	B57 D30 C	D	65
xDrive 40e	08.2015 → 07.2018	N20 B20 A	AB	57	xDrive M 50 i	07.2019 →	N63 B44 D	B	83
xDrive 40e	08.2015 → 07.2018	N20 B20 A	AB	57	<b>Z3 (E36)</b>				
xDrive 50 i	08.2013 → 07.2018	N63 B44 B	B	80	2.5i 24V (USA)	01.1999 → 12.2002	M52 B25 (256S3)	B	40
xDrive 50 i	08.2013 → 07.2018	N63 B44 B	B	80	2.5i 24V (USA)	01.1999 → 12.2002	M52 B25 (256S4)	B	40
<b>X5 (G05, F95)</b>					<b>Z3 Coupe (E36)</b>				
M50 i xDrive	08.2019 →	N63 B44 D	B	83	2.5i 24V (USA)	01.1999 → 12.2002	M54 B25 (256S5)	B	40
xDrive 25 d	08.2019 →	B47 D20 B	D	64	<b>Z3 Roadster (E36)</b>				
xDrive 25 d	08.2019 →	B47 D20 B	D	64	2.8 i	01.1998 → 08.1998	M52 B28 (286S1)	B	40
xDrive 30 d	08.2018 → 07.2020	B57 D30 A	D	63	2.8 i	09.1998 → 05.2000	M52 B28 (286S2)	B	40
xDrive 30 d	08.2018 → 07.2020	B57 D30 A	D	63	3.0 i	06.2000 → 06.2003	M54 B30 (306S3)	B	40
xDrive 30 d Mild-Hybrid	08.2020 →	B57 D30 B	D	62	3.0 i	01.2001 → 12.2002	M54 B30 (306S3)	B	40
xDrive 30 d Mild-Hybrid	08.2020 →	B57 D30 B	D	62	<b>Z4 Roadster (E86)</b>				
xDrive 30 i	09.2019 →	B48 B20 B	B	26	1.8 i	10.1995 → 10.1998	M43 B18 (184E2)	AB	56
xDrive 40 d Mild-Hybrid	05.2020 →	B57 D30 B	D	62	1.9 i	11.1995 → 03.1999	M44 B19 (194S1)	B	70
xDrive 50 i	08.2018 →	N63 B44 D	B	83	2.0 i	04.1999 → 01.2003	M52 B20 (206S4)	B	10
xDrive M 50 d	08.2018 →	B57 D30 C	D	65	2.2 i	08.2000 → 01.2003	M54 B22 (226S1)	B	11
<b>X6 (E71)</b>					<b>Z4 Coupe (E86)</b>				
40d 3.0 24V	04.2010 →	N57 D30 B	D	63	2.2 i	10.2000 → 06.2002	M54 B22 (226S1)	B	11
<b>X6 (E71, E72)</b>					<b>Z4 Roadster (E85)</b>				
ActiveHybrid	01.2009 → 10.2011	N63 B44 A	B	80	2.5 i	09.1998 → 09.2000	M52 B25 (256S4)	B	40
ActiveHybrid xDrive	01.2009 → 10.2011	N63 B44 A	B	80	2.5 i	10.2000 → 08.2002	M54 B25 (256S5)	B	40
M	07.2008 → 06.2014	S63 B44 A	B	81	2.8 i	01.1996 → 07.2000	M52 B28 (286S1)	B	40
M	07.2009 → 07.2014	S63 B44 A	B	81	2.8 i	01.1996 → 07.2000	M52 B28 (286S2)	B	40
M 50 d	08.2011 → 06.2014	N57 D30 C	D	63	2.8 i	11.1996 → 05.2000	M52 B28 (286S1)	B	40
xDrive 30 d	04.2008 → 03.2010	M57 D30 (306D3)	D	60	3.0 i	06.2000 → 12.2002	M54 B30 (306S3)	B	40
xDrive 30 d	04.2010 → 07.2014	N57 D30 A	D	62	3.0 i	06.2000 → 01.2003	M54 B30 (306S3)	B	40
xDrive 30 d	04.2010 → 07.2014	N57 D30 A	D	62	<b>Z4 Roadster (E85)</b>				
xDrive 35 d	01.2008 → 03.2010	M57 D30 (306D5)	D	60	2.5 i	11.2006 → 04.2008	M54 B25 (256S5)	B	40
xDrive 35 i	06.2007 → 03.2010	N54 B30 A	B	47	3.0 si	03.2006 → 08.2008	N52 B30 A	B	71
xDrive 35 i	01.2008 → 06.2014	N54 B30 A	B	47	3.0 si	03.2006 → 01.2009	N52 B30 A	B	71
xDrive 35 i	01.2008 → 06.2014	N55 B30 A	B	46	3.0 si	04.2006 → 08.2008	N52 B30 A	B	71
xDrive 35 i	01.2008 → 07.2014	N54 B30 A	B	47	3.0 si	04.2006 → 08.2008	N52 B30 BF	B	71
xDrive 35 i	01.2008 → 07.2014	N55 B30 A	B	46	<b>Z4 Roadster (E85)</b>				
xDrive 35 i	07.2009 → 06.2014	N55 B30 A	B	46	2.0 i	03.2005 → 02.2009	N46 B20 B	B	42
xDrive 40 d	07.2009 → 06.2014	N57 D30 B	D	63	2.2 i	10.2003 → 10.2005	M54 B22 (226S1)	B	11
xDrive 50 i	10.2007 → 06.2014	N63 B44 A	B	80	2.5 i	12.2002 → 12.2005	M54 B25 (256S5)	B	40
xDrive 50 i	07.2008 → 07.2014	N63 B44 A	B	80	2.5 i	09.2005 → 02.2009	N52 B25 A	B	22
<b>X6 (F16, F86)</b>					<b>Z4 Roadster (E85)</b>				
M 50 d	08.2014 → 07.2019	N57 D30 C	D	63	2.5 si	09.2005 → 02.2009	N52 B25 A	B	22
sDrive 35 i	08.2014 → 07.2019	N55 B30 A	B	46	2.5 si	09.2005 → 02.2009	N52 B25 AF	B	22
xDrive 28 i	06.2015 → 07.2019	N20 B20 A	AB	57	2.5 si	01.2006 → 08.2008	N52 B25 A	B	22
xDrive 30 d	08.2014 → 07.2019	N57 D30 A	D	62	3.0 i	12.2002 → 12.2005	M54 B30 (306S3)	B	40
xDrive 30 d	08.2014 → 07.2019	N57 D30 A	D	62	3.0 si	09.2005 → 12.2008	N52 B30 A	B	71
xDrive 30 d	08.2014 → 07.2019	N57 D30 A	D	62	3.0 si	01.2006 → 08.2008	N52 B30 A	B	71
xDrive 30 d	08.2014 → 07.2019	N57 D30 A	D	62	3.0 si	01.2006 → 08.2008	N52 B30 A	B	71
xDrive 30 d	08.2014 → 07.2019	N57 D30 A	D	62	3.0 si	01.2006 → 08.2008	N52 B30 BF	B	71
xDrive 30 d	12.2014 → 07.2019	N57 D30 A	D	62	3.0 si	01.2006 → 08.2008	N52 B30 BF	B	71
xDrive 30 d	09.2016 → 07.2019	N57 D30 A	D	62	<b>Z4 Roadster (E89)</b>				
					sDrive 18 i	04.2013 → 08.2016	N20 B20 A	AB	57
					sDrive 20 i	09.2011 → 08.2016	N20 B20 A	AB	57

		Pos			Pos		
sDrive 20 i	09.2011 → 08.2016	N20 B20 A AB	57	540 d xDrive	07.2017 →	B57 D30 B D	62
sDrive 23 i	03.2009 → 08.2011	N52 B25 A B	22	540 i xDrive	03.2017 →	B58 B30 A B	26
sDrive 23 i	03.2009 → 08.2011	N52 B25 BF B	22	<b>X1 Van (F48)</b>			
sDrive 28 i	09.2011 → 08.2016	N20 B20 A AB	57	sDrive 18 d	07.2015 →	B47 C20 A D	63
sDrive 30 i	02.2009 → 08.2011	N52 B30 A B	71	sDrive 18 d	03.2018 →	B47 C20 B D	64
sDrive 30 i	02.2009 → 08.2011	N52 B30 B B	71	sDrive 18 i	07.2017 →	B38 A15 A B	25
sDrive 30 i	02.2009 → 08.2011	N52 B30 BF B	71	sDrive 20 d	11.2015 →	B47 C20 A D	63
sDrive 30 i	05.2009 → 08.2011	N52 B30 A B	71	sDrive 20 d	11.2017 →	B47 C20 B D	64
sDrive 35 i	02.2009 → 08.2016	N54 B30 A B	47	sDrive 20 i	07.2017 →	B48 A20 A AB	30
sDrive 35 i	02.2009 → 08.2016	N54 B30 A B	47	xDrive 20 d	07.2015 →	B47 C20 A D	63
sDrive 35 is	03.2010 → 08.2016	N54 B30 A B	47	xDrive 20 d	11.2017 →	B47 C20 B D	64
<b>Z4 Roadster (G29)</b>				<b>X3 Van (G01)</b>			
sDrive 20 i	11.2018 →	B48 B20 B B	26	sDrive 18 d	04.2018 →	B47 D20 A D	63
sDrive 20 i	11.2018 →	B48 B20 B B	26	sDrive 18 d	05.2019 →	B47 D20 B D	64
sDrive 30 i	11.2018 →	B48 B20 B B	26	xDrive 20 d	08.2017 →	B47 D20 A D	63
<b>Z8 Roadster (E52)</b>				xDrive 20 d	05.2019 →	B47 D20 B D	64
4.9	01.2000 → 12.2003	S62 B50 (508S1) B	94	xDrive 20 i	12.2017 →	B48 B20 A AB	31
<b>i8 (I12)</b>				xDrive 20 i	09.2018 →	B48 B20 B B	26
hybrid	03.2014 → 02.2018	B38 K15 A B	24	xDrive 30 d	08.2017 →	B57 D30 A D	63
hybrid	03.2014 → 06.2020	B38 K15 A B	24	xDrive 30 i	08.2017 →	B48 B20 B B	26
hybrid	03.2018 → 06.2020	B38 K15 A B	24	xDrive M40 i	08.2017 → 08.2019	B58 B30 A B	26
<b>i8 Roadster (I15)</b>				<b>X5 Van (G05)</b>			
hybrid	03.2018 → 06.2020	B38 K15 A B	24	xDrive 30 d	11.2019 →	B57 D30 A D	63
hybrid	03.2018 → 06.2020	B38 K15 A B	24				
<b>1 Van (F20)</b>							
118 d	03.2015 → 06.2019	B47 D20 A D	63				
118 i	07.2015 → 06.2019	B38 B15 A B	27				
120 d	03.2015 → 06.2019	B47 D20 A D	63				
120 i	07.2016 → 06.2019	B48 B20 A AB	31				
M 140 i	07.2016 → 06.2019	B58 B30 A B	26				
<b>2 Active Tourer Van (F45)</b>							
218 d	07.2014 → 02.2018	B47 C20 A D	63				
218 d	03.2018 →	B47 C20 B D	64				
218 i	03.2018 →	B38 A15 A B	25				
220 d	11.2014 → 02.2018	B47 C20 A D	63				
220 d	03.2018 →	B47 C20 B D	64				
<b>2 Gran Tourer Van (F46)</b>							
218 d	07.2014 → 02.2018	B47 C20 A D	63				
218 d	03.2018 →	B47 C20 B D	64				
218 i	03.2018 →	B38 A15 A B	25				
220 d	07.2014 → 02.2018	B47 C20 A D	63				
220 d	03.2018 →	B47 C20 B D	64				
<b>3 Touring Van (F31)</b>							
330 d	07.2012 → 06.2019	N57 D30 A D	62				
330 d xDrive	03.2013 → 06.2019	N57 D30 A D	62				
330 i	07.2015 → 06.2019	B48 B20 A AB	31				
340 i	07.2015 → 06.2019	B58 B30 A B	26				
<b>3 Touring Van (G21)</b>							
320 d	07.2019 → 02.2020	B47 D20 B D	64				
320 d Mild-Hybrid	03.2020 →	B47 D20 B D	64				
320 d Mild-Hybrid xDrive	03.2020 →	B47 D20 B D	64				
320 d xDrive	07.2019 → 02.2020	B47 D20 B D	64				
320 i	11.2019 →	B48 B20 A AB	31				
330 d	11.2019 →	B57 D30 A D	63				
330 d xDrive	11.2019 →	B57 D30 A D	63				
330 i	07.2019 →	B48 B20 B B	26				
<b>5 Touring Van (G31)</b>							
520 d	03.2017 → 06.2018	B47 D20 A D	63				
520 d	07.2018 → 06.2018	B47 D20 B D	64				
520 d xDrive	07.2017 → 06.2018	B47 D20 A D	63				
520 d xDrive	07.2018 → 06.2018	B47 D20 B D	64				
520 i	07.2017 →	B48 B20 A AB	31				
530 d	03.2017 →	B57 D30 A D	63				
530 d xDrive	03.2017 →	B57 D30 A D	63				
530 i	03.2017 →	B48 B20 B B	26				
530 i xDrive	07.2017 →	B48 B20 B B	26				

					Reference	Item No.	
<b>1</b>		<b>67</b>					
<b>K 589 74 kW</b>		B	4	987 cm <sup>3</sup> 4V	74 kW (100 PS) 11:1	70,00 mm	
	IN [4]	11,54 x 6 x 45,0	B1			11 12 1 461 561 <b>81-11106</b>	
<b>2</b>		<b>68</b>					
<b>R 50</b>		B	2	513 cm <sup>3</sup> 2V	19 kW (26 PS) 6,8/7,5	70,60 mm	
	IN/EX [4]	13,00 x 7 x 43,0	B1			22 41 0 411 804 <b>81-1116</b>	
	IN/EX [4]	13,10 x 7 x 43,0	B1			24 01 0 411 819 <b>81-1119</b>	
	IN/EX [4]	13,20 x 7 x 43,0	B1			24 01 0 411 829 <b>81-1120</b>	
<b>3</b>		<b>70</b>					
<b>R 45</b>		B	2	473 cm <sup>3</sup> 2V	20 kW (27 PS) 8,2:1	61,50 mm	
<b>R 45 S</b>		B	2	473 cm <sup>3</sup> 2V	26 kW (35 PS) 9,2:1	61,50 mm	
	IN/EX [4]	14,14 x 7 x 42,0	B1			11 12 1 335 568 <b>81-1156</b>	
						11 12 1 338 061	
						11 12 1 338 435	
						11 12 1 338 709	
	IN/EX [4]	14,24 x 7 x 42,0	B1			11 12 1 335 569 <b>81-1157</b>	
						11 12 1 338 062	
						11 12 1 338 436	
						11 12 1 338 710	
<b>4</b>		<b>73,5</b>					
<b>R 60</b>		B	2	599 cm <sup>3</sup> 2V	30 kW (40 PS) 9:1	70,60 mm	
	IN [2]	42,0 x 8 x 98,6	S - Cr -	- 45° -	22 - III	11 34 1 250 234 <b>1135</b>	
	EX [2]	38,0 x 8 x 98,6	RA/S- Cr -	- 45° - VS -	22 - III	11 34 1 337 453 <b>111201</b>	
	[50]	Ø 8 mm				11 34 1 710 975 <b>MK-8H</b>	
<b>5</b>		<b>77</b>					
<b>N13 B16 A</b>	07.2011 →	B (A)	4	1598 cm <sup>3</sup> 4V	75-130 kW (102-177 PS) 10,5	85,80 mm	
41 267 6..							
	IN [2]	29,7 x 5 x 95,0	S - Cr -	- 45° - Y -	22 - III	11 34 7 585 901 <b>111226</b> <small>NEW</small>	
	EX [2]	26,2 x 5 x 110,1	RA/S- -	- 45° - VS -	22 - III	11 34 7 547 187 <b>539031</b>	
	[50]	Ø 5 mm				<b>MK-5H</b>	
	IN [4]	9,05 x 5.01 x 41,5	B1			<b>81-11121</b>	
	IN [4]	9,15 x 5.01 x 41,5	B1			<b>81-11122</b> (1)	
	EX [4]	9,05 x 5.01 x 44,5	B1			<b>81-11123</b>	
	EX [4]	9,15 x 5.01 x 44,5	B1			<b>81-11124</b> (1)	
	(1)	1. oversize					
	[8]	H 12 x 30				11 33 7 549 632 <b>50 006 135</b>	
	[8]	H 12 x 40				11337549633 <b>50 007 614</b>	
	[4]					11 37 7 539 966 <b>50 007 850</b> (2)	
	(2)	Zwischenhebel					
<b>6</b>		<b>78</b>					
<b>N47 D16 A Euro 5</b>	12.2011 →	D (A)	4	1598 cm <sup>3</sup> 4V	70-85 kW (95-116 PS) 16,5	83,60 mm	
	IN [2]	24,9 x 5 x 94,0	S - -	- 45° -	22 - III	11 34 7 812 618 <b>111227</b> <small>NEW</small>	
	EX [2]	21,2 x 5 x 94,0	RA/S- Cr -	- 45° -	22 - III	11 34 7 812 616 <b>111228</b> <small>NEW</small>	
Fortsetzung nächste Seite / continued on next page / suite page suivante / continuación página próxima / Продолжение на следующей странице							



					Reference	Item No.
[50]	Ø 5 mm					<b>MK-5H</b>
IN/EX [4]	10,05 x 5 x 36,0	B1				<b>81-11119</b> <small>NEW</small>
IN/EX [4]	10,15 x 5 x 36,0	B1				<b>81-11120</b> <small>NEW</small> (1)
	(1) 1. oversize					
[4]					11 33 7 797 710 11 33 8 576 634	<b>50 007 810</b>

**7** **79**
**K1200 (4ZYL. REIHE)** B 4 1157 cm<sup>3</sup> 4V 120-123 kW (160-167 PS) 13,0:1 59,00 mm

IN [2]	39,0 x 5,5 x 99,8	S - Ni -	- 45° -	- 1 -		<b>111231</b> <small>NEW</small>
EX [2]	33,0 x 5,5 x 99,8	RA/S- Ni - Na	- 30° - VS -	- 1 -		<b>111232</b> <small>NEW</small>

**8** **80**

<b>M20 B20</b>		B (NA)	6	1990 cm <sup>3</sup> 2V	90-110 kW (122-150 PS)	8,8-9,9	66,00 mm
<b>M20 B20 L</b>	09.1982 → 1987	B	6	1991 cm <sup>3</sup> 2V	92 kW (125 PS)	9,4:1	66,00 mm
<b>M20 B20 LE</b>		B	6	1991 cm <sup>3</sup> 2V	95 kW (129 PS)	9,8:1	66,00 mm
<b>M20 B23 K</b>		B	6	2316 cm <sup>3</sup> 2V	105 kW (143 PS)	9,5:1	76,80 mm
<b>M20 B23 L</b>		B	6	2316 cm <sup>3</sup> 2V	110 kW (150 PS)	9,8:1	76,80 mm
<b>M20 B23 LE</b>		B	6	2316 cm <sup>3</sup> 2V	102 kW (109 PS)	9,8:1	76,80 mm

IN [2]	40,0 x 7 x 102,5	S - -	- 45° -	- 22 - III	11 34 1 265 453 11 34 1 267 687 11 34 1 267 721	<b>1155</b> (1)
EX [2]	34,0 x 7 x 102,5	A/S - Cr -	- 45° - VS -	- 22 - III	11 34 1 267 722 11 34 1 280 643	<b>1156</b>
	(1) für Kompressor/for compressor/pour compresseur/para compresor/для компрессора					

[50]	Ø 7 mm				11 34 1 307 136	<b>MK-7H</b>
IN/EX [6]	13,00 x 7 x 45,0	B1			11 12 1 280 523	<b>81-1158</b>
IN/EX [6]	13,14 x 7 x 45,0	B1			11 12 1 267 676	<b>81-1159</b>
IN/EX [6]	13,24 x 7 x 45,0	B1			11 12 1 267 677	<b>81-1160</b>
IN/EX [6]	13,34 x 7 x 45,0	B1			11 12 1 267 678	<b>81-1161</b>

**9** **80**
**M50 B20 (206S1)** 04.1990 → 11.1998 B (NA) 6 1990 cm<sup>3</sup> 4V 110 kW (150 PS) 10,5 66,00 mm  
**M50 B20 (206S2)** 04.1990 → 11.1999 B (NA) 6 1990 cm<sup>3</sup> 4V 110 kW (150 PS) 11 66,00 mm

IN [2]	30,0 x 6 x 107,1	S - -	- 45° -	- 22 - III	11 34 1 438 381 11 34 1 438 449 11 34 1 738 214 11 34 1 738 220	<b>11613</b>
IN [2]	30,0 x 7 x 107,7	S - -	- 45° -	- 22 - III	11 34 1 722 896 11 34 1 722 910	<b>11357</b>
EX [2]	27,0 x 6 x 106,2	A/S - Cr -	- 45° - VS -	- 22 - III	11 34 1 738 215 11 34 1 738 221 11 34 7 502 173 11 34 7 502 351	<b>11612</b>
EX [2]	27,0 x 7 x 106,8	A/S - Cr -	- 45° - VS -	- 22 - III	11 34 1 722 897 11 34 1 722 911	<b>11358</b>
[50]	Ø 6 mm				11 34 0 150 844 11 34 1 461 405	<b>MK-6H</b>
[50]	Ø 7 mm				11 34 1 307 136	<b>MK-7H</b>
IN/EX [6]	12,53 x 6 x 43,5	B1			11 12 1 735 534	<b>81-11112</b>
IN/EX [6]	12,54 x 7 x 43,5	B1			11 12 1 715 373	<b>81-11101</b>
IN/EX [6]	12,55 x 7 x 43,5	B1			11 12 1 715 373	<b>81-11110</b>
IN/EX [6]	12,73 x 6 x 43,5	B1				<b>81-11113</b>

Fortsetzung nächste Seite / continued on next page / suite page suivante / continuación página próxima / Продолжение на следующей странице

					Reference	Item No.
[8]	H 35 x 26				11 32 1 739 299	50 006 475

<b>10</b>		<b>80</b>						
<b>M52 B20 (206S3)</b>	01.1991 → 11.1999	B (NA)	6	1990 cm <sup>3</sup>	4V	100-110 kW	(136-150 PS)	11 66,00 mm
<b>M52 B20 (206S4)</b>	03.1998 → 06.2003	B (NA)	6	1990 cm <sup>3</sup>	4V	100-110 kW	(136-150 PS)	11 66,00 mm

IN [2]	30,0 x 6 x 107,1	S - -	- 45° - -	22 - III	11 34 1 438 381 11 34 1 438 449 11 34 1 738 214 11 34 1 738 220	<b>11613</b>
IN [2]	30,0 x 7 x 107,7	S - -	- 45° - -	22 - III	11 34 1 722 896 11 34 1 722 910	<b>11357</b>
EX [2]	27,0 x 6 x 106,2	A/S - Cr -	- 45° - VS -	22 - III	11 34 1 738 215 11 34 1 738 221 11 34 7 502 173 11 34 7 502 351	<b>11612</b>
EX [2]	27,0 x 7 x 106,8	A/S - Cr -	- 45° - VS -	22 - III	11 34 1 722 897 11 34 1 722 911	<b>11358</b>
[50]	∅ 6 mm				11 34 0 150 844 11 34 1 461 405	<b>MK-6H</b>
[50]	∅ 7 mm				11 34 1 307 136	<b>MK-7H</b>
IN/EX [6]	12,53 x 6 x 43,5	B1			11 12 1 735 534	<b>81-11112</b>
IN/EX [6]	12,54 x 7 x 43,5	B1			11 12 1 715 373	<b>81-11101</b>
IN/EX [6]	12,55 x 7 x 43,5	B1			11 12 1 715 373	<b>81-11110</b>
IN/EX [6]	12,73 x 6 x 43,5	B1				<b>81-11113</b>
[8]	H 33 x 24 x 24				11 32 1 748 880 11 32 1 748 881 11 32 1 748 882 11 32 1 748 884	<b>50 006 409</b>

<b>11</b>		<b>80</b>						
<b>M54 B22 (226S1)</b>	01.2000 → 03.2010	B (NA)	6	2171 cm <sup>3</sup>	4V	120-125 kW	(163-170 PS)	10,8 72,00 mm

IN [2]	30,0 x 6 x 107,1	S - -	- 45° - -	22 - III	11 34 1 438 381 11 34 1 438 449 11 34 1 738 214 11 34 1 738 220	<b>11613</b>
EX [2]	27,0 x 6 x 106,2	A/S - Cr -	- 45° - VS -	22 - III	11 34 1 738 215 11 34 1 738 221 11 34 7 502 173 11 34 7 502 351	<b>11612</b>
[50]	∅ 6 mm				11 34 0 150 844 11 34 1 461 405	<b>MK-6H</b>
IN/EX [6]	12,53 x 6 x 43,5	B1			11 12 1 735 534	<b>81-11112</b>
IN/EX [6]	12,73 x 6 x 43,5	B1				<b>81-11113</b>
[8]	H 33 x 24 x 24				11 32 1 748 880 11 32 1 748 881 11 32 1 748 882 11 32 1 748 884	<b>50 006 409</b>

<b>12</b>		<b>80</b>						
<b>M20 B20 M0.E8</b>		B	6	1991 cm <sup>3</sup>	2V	95 kW	(129 PS)	9,4:1 66,00 mm

IN [2]	40,0 x 7 x 102,5	S - -	- 45° - -	22 - III	11 34 1 265 453 11 34 1 267 687 11 34 1 267 721	<b>1155</b> (1)
EX [2]	34,0 x 7 x 102,5	A/S - Cr -	- 45° - VS -	22 - III	11 34 1 267 722 11 34 1 280 643	<b>1156</b>
(1) für Kompressor/for compressor/pour compresseur/para compresor/для компрессора						

Fortsetzung nächste Seite / continued on next page / suite page suivante / continuación página próxima / Продолжение на следующей странице

					Reference	Item No.
[50]	Ø 7 mm				11 34 1 307 136	<b>MK-7H</b>
IN/EX [6]	13,00 x 7 x 45,0	B1			11 12 1 280 523	<b>81-1158</b>
IN/EX [6]	13,14 x 7 x 45,0	B1			11 12 1 267 676	<b>81-1159</b>
IN/EX [6]	13,24 x 7 x 45,0	B1			11 12 1 267 677	<b>81-1160</b>
IN/EX [6]	13,34 x 7 x 45,0	B1			11 12 1 267 678	<b>81-1161</b>
					11 31 1 716 139	<b>50 006 241</b> (2)
(2) Schalenhartguss/chilled cast iron/pièce moulée trempée en surface/fundición en coquilla/Отливка с отбелнным поверхностным слоем						

**13** **80**

<b>M50 B20 M</b>		<b>B</b>	<b>6</b>	<b>1991 cm<sup>3</sup> 4V</b>	<b>110 kW</b>	<b>(150 PS) 10,5:1</b>	<b>66,00 mm</b>
IN [2]	30,0 x 6 x 107,1	S - -	- 45° - -	22 - III	11 34 1 438 381 11 34 1 438 449 11 34 1 738 214 11 34 1 738 220	<b>11613</b>	
IN [2]	30,0 x 7 x 107,7	S - -	- 45° - -	22 - III	11 34 1 722 896 11 34 1 722 910	<b>11357</b>	
EX [2]	27,0 x 6 x 106,2	A/S - Cr -	- 45° - VS -	22 - III	11 34 1 738 215 11 34 1 738 221 11 34 7 502 173 11 34 7 502 351	<b>11612</b>	
EX [2]	27,0 x 7 x 106,8	A/S - Cr -	- 45° - VS -	22 - III	11 34 1 722 897 11 34 1 722 911	<b>11358</b>	
[50]	Ø 6 mm				11 34 0 150 844 11 34 1 461 405	<b>MK-6H</b>	
[50]	Ø 7 mm				11 34 1 307 136	<b>MK-7H</b>	
IN/EX [6]	12,53 x 6 x 43,5	B1			11 12 1 735 534	<b>81-11112</b>	
IN/EX [6]	12,54 x 7 x 43,5	B1			11 12 1 715 373	<b>81-11101</b>	
IN/EX [6]	12,55 x 7 x 43,5	B1			11 12 1 715 373	<b>81-11110</b>	
IN/EX [6]	12,73 x 6 x 43,5	B1				<b>81-11113</b>	

**14** **80**

<b>M21 D24 (246DA)</b>		09.1985 → 11.1988	D (NA)	6	2443 cm <sup>3</sup> 2V	63 kW	(86 PS) 22	81,00 mm
<b>M21 D24 (246TA)</b>		09.1983 → 12.1987	D (A)	6	2443 cm <sup>3</sup> 2V	85 kW	(115 PS) 22	81,00 mm
<b>M21 D24 (246TB)</b>		09.1987 → 06.1993	D (A)	6	2443 cm <sup>3</sup> 2V	85 kW	(115 PS) 22	81,00 mm
IN [2]	35,0 x 7 x 114,3	A/S - Cr -	- 45° - VS -	22 - III	11 34 2 242 621 11 34 2 242 624	<b>1180</b>		
EX [2]	31,0 x 7 x 114,3	A/S - Cr -	- 45° - VS -	22 - III	11 34 1 275 965 11 34 2 242 622 11 34 2 242 623	<b>1184</b>		
[50]	Ø 7 mm				11 34 1 307 136	<b>MK-7H</b>		

**15** **80**

<b>M41 D17 (174T1)</b>		01.1995 → 08.2000	D (A)	4	1665 cm <sup>3</sup> 2V	66 kW	(90 PS) 22	82,80 mm
IN [2]	36,0 x 6 x 103,7	A/S - Cr -	- 45° - VS -	22 - III	11 34 2 244 814	<b>11732</b>		
[50]	Ø 6 mm				11 34 0 150 844 11 34 1 461 405	<b>MK-6H</b>		
IN/EX [6]	12,55 x 6 x 39,5	B1			11 12 2 244 464	<b>81-11114</b>		
IN/EX [6]	12,75 x 6 x 39,5	B1				<b>81-11115</b>		

Fortsetzung nächste Seite / continued on next page / suite page suivante / continuación página próxima / Продолжение на следующей странице

**B**

					Reference	Item No.
[8]	H 35 x 26				11 32 1 739 299	50 006 475
<b>16</b>	<b>80</b>					
<b>M57 D25 (256D1)</b>	02.2000 → 05.2004	D (A)	6	2497 cm <sup>3</sup>	4V 120 kW (163 PS)	17,5 82,80 mm
<b>M57 D25 (256D2)</b>	03.2004 → 03.2010	D (A)	6	2497 cm <sup>3</sup>	4V 120-130 kW (163-177 PS)	17 82,80 mm
IN/EX [2]	25,9 x 6 x 99,9	RA/S-	Cr -	- 45° - VS -	22 - III	11 34 2 247 077 <b>111113</b>
[50]	∅ 6 mm					11 34 0 150 844 11 34 1 461 405 <b>MK-6H</b>
IN/EX [6]	11,54 x 6 x 39,0	B1				<b>81-11116</b>
[8]	H 12 x 34,5 x 34,5					11 33 2 247 722 11 33 2 249 817 <b>50 006 414</b>
[4]						11 12 2 247 056 11 33 2 248 878 <b>50 006 132</b>
<b>17</b>	<b>80</b>					
<b>M21 D24 W</b>		D (NA)	6	2443 cm <sup>3</sup>	2V 63 kW (86 PS)	22:1 81,00 mm
<b>M21 D24 WA</b>		D (A)	6	2443 cm <sup>3</sup>	2V 85 kW (115 PS)	22:1 81,00 mm
IN [2]	35,0 x 7 x 114,3	A/S -	Cr -	- 45° - VS -	22 - III	11 34 2 242 621 11 34 2 242 624 <b>1180</b>
EX [2]	31,0 x 7 x 114,3	A/S -	Cr -	- 45° - VS -	22 - III	11 34 1 275 965 11 34 2 242 622 11 34 2 242 623 <b>1184</b>
[50]	∅ 7 mm					11 34 1 307 136 <b>MK-7H</b>
IN/EX [6]	13,00 x 7 x 45,0	B1				11 12 1 280 523 <b>81-1158</b>
IN/EX [6]	13,14 x 7 x 45,0	B1				11 12 1 267 676 <b>81-1159</b>
IN/EX [6]	13,24 x 7 x 45,0	B1				11 12 1 267 677 <b>81-1160</b>
IN/EX [6]	13,34 x 7 x 45,0	B1				11 12 1 267 678 <b>81-1161</b>
IN [6]	13,07 x 7 x 45,0	B1				<b>81-11103</b>
EX [6]	13,07 x 7 x 52,0	B1				<b>81-11104</b>
EX [6]	13,23 x 7 x 52,0	B1				<b>81-11108</b>
<b>18</b>	<b>80</b>					
<b>M41 B17</b>		D (LA)	4	1665 cm <sup>3</sup>	2V 66 kW (90 PS)	22:1 82,80 mm
94 347 6..						
IN [2]	36,0 x 6 x 103,7	A/S -	Cr -	- 45° - VS -	22 - III	11 34 2 244 814 <b>11732</b>
[50]	∅ 6 mm					11 34 0 150 844 11 34 1 461 405 <b>MK-6H</b>
IN/EX [6]	12,55 x 6 x 39,5	B1				11 12 2 244 464 <b>81-11114</b>
IN/EX [6]	12,75 x 6 x 39,5	B1				<b>81-11115</b>
<b>19</b>	<b>80</b>					
<b>M51 D25 (Inter.)</b>		D (A)	6	2503 cm <sup>3</sup>	2V 105 kW (143 PS)	22:1 82,80 mm (1)
94 347 6..						
(1) charge intercooling						
IN [2]	36,0 x 6 x 103,7	A/S -	Cr -	- 45° - VS -	22 - III	11 34 2 244 814 <b>11732</b>

Fortsetzung nächste Seite / continued on next page / suite page suivante / continuación página próxima / Продолжение на следующей странице



					Reference	Item No.
[50]	Ø 6 mm				11 34 0 150 844	<b>MK-6H</b>
[50]	Ø 7 mm				11 34 1 461 405 11 34 1 307 136	<b>MK-7H</b>
IN/EX [6]	12,55 x 6 x 39,5	B1			11 12 2 244 464	<b>81-11114</b>
IN/EX [6]	12,75 x 6 x 39,5	B1				<b>81-11115</b>
IN/EX [6]	13,00 x 7 x 45,0	B1			11 12 1 280 523	<b>81-1158</b>
IN/EX [6]	13,14 x 7 x 45,0	B1			11 12 1 267 676	<b>81-1159</b>
IN/EX [6]	13,24 x 7 x 45,0	B1			11 12 1 267 677	<b>81-1160</b>
IN/EX [6]	13,34 x 7 x 45,0	B1			11 12 1 267 678	<b>81-1161</b>
IN [6]	13,07 x 7 x 45,0	B1				<b>81-11103</b>
EX [6]	13,07 x 7 x 52,0	B1				<b>81-11104</b>
EX [6]	13,23 x 7 x 52,0	B1				<b>81-11108</b>
[8]	H 35 x 26				11 32 1 739 299	<b>50 006 475</b>

**20** **80**

<b>M51 D25 OL</b>	D (LA)	6	2497 cm <sup>3</sup>	2V	105 kW	(143 PS)	22:1	82,80 mm
<b>M51 D25 UL</b>	D (A)	6	2497 cm <sup>3</sup>	2V	85 kW	(115 PS)	22:1	82,80 mm (1)
94 347 6..								
(1) super charged								

IN [2]	36,0 x 6 x 103,7	A/S - Cr -	- 45° - VS -	22 - III	11 34 2 244 814	<b>11732</b>
[50]	Ø 6 mm				11 34 0 150 844	<b>MK-6H</b>
[50]	Ø 7 mm				11 34 1 461 405 11 34 1 307 136	<b>MK-7H</b>
IN/EX [6]	12,55 x 6 x 39,5	B1			11 12 2 244 464	<b>81-11114</b>
IN/EX [6]	12,75 x 6 x 39,5	B1				<b>81-11115</b>
IN [6]	13,07 x 7 x 45,0	B1				<b>81-11103</b>
EX [6]	13,07 x 7 x 52,0	B1				<b>81-11104</b>
EX [6]	13,23 x 7 x 52,0	B1				<b>81-11108</b>
[8]	H 35 x 26				11 32 1 739 299	<b>50 006 475</b>

**21** **80**

<b>M51 D25 TU UL</b>	D (A)	6	2497 cm <sup>3</sup>	2V	85 kW	(115 PS)	22:1	82,80 mm
94 347 6..								

IN [2]	36,0 x 6 x 103,7	A/S - Cr -	- 45° - VS -	22 - III	11 34 2 244 814	<b>11732</b>
[50]	Ø 6 mm				11 34 0 150 844	<b>MK-6H</b>
[50]	Ø 7 mm				11 34 1 461 405 11 34 1 307 136	<b>MK-7H</b>
IN/EX [6]	12,55 x 6 x 39,5	B1			11 12 2 244 464	<b>81-11114</b>
IN/EX [6]	12,75 x 6 x 39,5	B1				<b>81-11115</b>
IN/EX [6]	13,00 x 7 x 45,0	B1			11 12 1 280 523	<b>81-1158</b>
IN/EX [6]	13,14 x 7 x 45,0	B1			11 12 1 267 676	<b>81-1159</b>
IN/EX [6]	13,24 x 7 x 45,0	B1			11 12 1 267 677	<b>81-1160</b>
IN/EX [6]	13,34 x 7 x 45,0	B1			11 12 1 267 678	<b>81-1161</b>
IN [6]	13,07 x 7 x 45,0	B1				<b>81-11103</b>
EX [6]	13,07 x 7 x 52,0	B1				<b>81-11104</b>
EX [6]	13,23 x 7 x 52,0	B1				<b>81-11108</b>

					Reference	Item No.	
<b>22</b>		<b>82</b>					
<b>N52 B25</b>	09.2008 → 12.2009	B (NA)	6	2497 cm <sup>3</sup>	4V	130-163 kW (177-222 PS)	11 78,80 mm
<b>N52 B25 A</b>	10.2004 → 12.2013	B (NA)	6	2497 cm <sup>3</sup>	4V	130-160 kW (177-218 PS)	11:1 78,80 mm
<b>N52 B25 AE</b>	04.2006 → 02.2012	B (NA)	6	2497 cm <sup>3</sup>	4V	130-140 kW (177-190 PS)	78,80 mm
<b>N52 B25 AF</b>	12.2004 → 10.2013	B (NA)	6	2497 cm <sup>3</sup>	4V	150-160 kW (204-218 PS)	78,80 mm
<b>N52 B25 B</b>	10.2004 → 12.2011	B (NA)	6	2497 cm <sup>3</sup>	4V	130-160 kW (177-218 PS)	78,80 mm
<b>N52 B25 BE</b>	10.2004 → 02.2012	B (NA)	6	2497 cm <sup>3</sup>	4V	130-140 kW (177-190 PS)	11:1 78,80 mm
<b>N52 B25 BF</b>	12.2004 → 10.2013	B (NA)	6	2497 cm <sup>3</sup>	4V	130-160 kW (177-218 PS)	11:1 78,80 mm
<b>N52 B25 C</b>		B	6	2497 cm <sup>3</sup>	4V	160 kW (218 PS)	11:1 78,80 mm
<b>N53 B25 A</b>	01.2007 → 12.2010	B (NA)	6	2497 cm <sup>3</sup>	4V	140 kW (190 PS)	12:1 78,80 mm
40 395 6.., 40 407 6..							
	IN [2] EX [2]	32,2 x 5 x 104,5 27,0 x 6 x 110,4	S - - RA/S- -	- 45° - - - 45° - -	22 - III 22 - III	11 34 7 539 919 11 34 7 553 774	<b>111217</b> <b>111218</b>
	[50] [50]	∅ 5 mm ∅ 6 mm				11 34 0 150 844 11 34 1 461 405	<b>MK-5H</b> <b>MK-6H</b>
	IN [6] IN [1] EX [6] EX [6] (1)	10,15 x 5 x 42,0 10,04 x 5 x 42,0 10,04 x 6 x 48,0 10,15 x 6 x 48,0 1. oversize	B1 B1 B1 B1				<b>81-11126</b> (1) <b>81-11125</b> <b>81-11127</b> <b>81-11128</b> (1)
	[8]	H 12 x 34,5				11 33 7 546 466 11 33 7 548 690	<b>50 006 492</b>
	[4]					11 33 7 559 797	<b>50 006 129</b>
<b>23</b>		<b>82</b>					
<b>N43 B16 A</b>	09.2007 → 10.2011	B (NA)	4	1599 cm <sup>3</sup>	4V	85-90 kW (115-122 PS)	12 75,70 mm
<b>N43 B16 AA</b>	03.2007 → 06.2013	B (NA)	4	1599 cm <sup>3</sup>	4V	89-90 kW (121-122 PS)	12 75,70 mm
40 089 6..							
	IN [2] EX [2]	30,0 x 6 x 106,7 27,0 x 6 x 114,6	S - - RA/S- Cr -	- 45° - - - 45° - VS -	22 - III 22 - III	11 34 7 555 760 11 34 7 552 053	<b>111211</b> <b>111212</b>
	[50]	∅ 6 mm				11 34 0 150 844 11 34 1 461 405	<b>MK-6H</b>
	IN/EX [6] IN/EX [4] (1)	10,02 x 6.01 x 39,0 10,15 x 6.01 x 39,0 1. oversize	B1 B1				<b>81-11117</b> <b>81-11118</b> <small>NEW</small> (1)
	[8]	H 12 x 34,5				11 33 7 546 466 11 33 7 548 690	<b>50 006 492</b>
	[4]					11 33 7 542 421	<b>50 006 128</b>
<b>24</b>		<b>82</b>					
<b>B38 K15 A</b>	03.2014 → 06.2020	B (A)	3	1499 cm <sup>3</sup>	4V	170 kW (231 PS)	94,60 mm
	IN [6] IN [1] EX [6] EX [6] (1)	10,15 x 5 x 42,0 10,04 x 5 x 42,0 10,04 x 6 x 48,0 10,15 x 6 x 48,0 1. oversize	B1 B1 B1 B1				<b>81-11126</b> (1) <b>81-11125</b> <b>81-11127</b> <b>81-11128</b> (1)

							Reference	Item No.	
<b>B</b>	<b>25</b>		<b>82</b>						
	<b>B38 A15 A Euro 6</b>	07.2014 →	B (A)	3	1499 cm <sup>3</sup>	4V	75-103 kW (102-140 PS)	11,0:1 94,60 mm	
	<b>B38 B15 Euro 6</b>		B (A)	3	1499 cm <sup>3</sup>	4V	100 kW (136 PS)	11,0:1 94,60 mm	
	<b>B48 B20 Euro 6</b>		B (A)	4		4V	170 kW (231 PS)	94,60 mm	
	IN [2]	30,1 x 5 x 99,2	S - -	-	- 45° -	-	22 - III	11 34 7 633 699	<b>111234</b>
	EX [2]	28,5 x 6 x 99,8	RA/S- Cr - Na	-	- 45° - VS -	-	22 - III	11 34 8 621 264	<b>111233</b>
	[50]	∅ 6 mm						11 34 0 150 844 11 34 1 461 405	<b>MK-6H</b>
<b>26</b>		<b>82</b>							
<b>B46 A20 B</b>	11.2014 →	B (A)	4	1998 cm <sup>3</sup>	4V	170 kW (231 PS)	11	94,60 mm	
<b>B48 B20 B</b>	07.2015 →	B (A)	4	1998 cm <sup>3</sup>	4V	120-195 kW (163-265 PS)		94,60 mm	
<b>B58 B30 A Euro 6</b>	07.2015 →	B (A)	6	2998 cm <sup>3</sup>	4V	239-265 kW (325-360 PS)	11	94,60 mm	
	IN [2]	30,1 x 5 x 99,2	S - -	-	- 45° -	-	22 - III	11 34 7 633 699	<b>111234</b>
	EX [2]	28,5 x 6 x 99,8	RA/S- Cr - Na	-	- 45° - VS -	-	22 - III	11 34 8 621 264	<b>111233</b>
	[50]	∅ 6 mm						11 34 0 150 844 11 34 1 461 405	<b>MK-6H</b>
	IN [6]	10,15 x 5 x 42,0	B1						<b>81-11126</b> (1)
	IN [1]	10,04 x 5 x 42,0	B1						<b>81-11125</b>
	EX [6]	10,04 x 6 x 48,0	B1						<b>81-11127</b>
	EX [6]	10,15 x 6 x 48,0	B1						<b>81-11128</b> (1)
	(1)	1. oversize							
<b>27</b>		<b>82</b>							
<b>B38 B15 A</b>	03.2015 →	B (A)	3	1499 cm <sup>3</sup>	4V	80-100 kW (109-136 PS)	11	94,60 mm	
	IN [2]	30,1 x 5 x 99,2	S - -	-	- 45° -	-	22 - III	11 34 7 633 699	<b>111234</b>
	EX [2]	28,5 x 6 x 99,8	RA/S- Cr - Na	-	- 45° - VS -	-	22 - III	11 34 8 621 264	<b>111233</b>
	[50]	∅ 6 mm						11 34 0 150 844 11 34 1 461 405	<b>MK-6H</b>
	IN [6]	10,15 x 5 x 42,0	B1						<b>81-11126</b> (1)
	IN [1]	10,04 x 5 x 42,0	B1						<b>81-11125</b>
	EX [6]	10,04 x 6 x 48,0	B1						<b>81-11127</b>
	EX [6]	10,15 x 6 x 48,0	B1						<b>81-11128</b> (1)
	(1)	1. oversize							
	[4]							11 37 7 539 966	<b>50 007 850</b> (2)
	(2)	Zwischenhebel							
<b>28</b>		<b>82</b>							
<b>R 65</b>		B	2	650 cm <sup>3</sup>	2V	33 kW (45 PS)	9,2:1	61,50 mm	
	IN/EX [4]	14,14 x 7 x 42,0	B1					11 12 1 335 568 11 12 1 338 061 11 12 1 338 435 11 12 1 338 709	<b>81-1156</b>
	IN/EX [4]	14,24 x 7 x 42,0	B1					11 12 1 335 569 11 12 1 338 062 11 12 1 338 436 11 12 1 338 710	<b>81-1157</b>
<b>29</b>		<b>82</b>							
<b>R 75</b>		B	2	745 cm <sup>3</sup>	2V	37 kW (50 PS)	9:1	70,60 mm	
	IN [2]	42,0 x 8 x 98,6	S - Cr -	-	- 45° -	-	22 - III	11 34 1 250 234	<b>1135</b>
	EX [2]	38,0 x 8 x 98,6	RA/S- Cr -	-	- 45° - VS -	-	22 - III	11 34 1 337 453	<b>111201</b>

Fortsetzung nächste Seite / continued on next page / suite page suivante / continuación página próxima / Продолжение на следующей странице

					Reference	Item No.
[50]	Ø 8 mm				11 34 1 710 975	<b>MK-8H</b>
	IN/EX [4] 14,10 x 8 x 44,0 IN/EX [4] 14,10 x 8 x 46,5 IN/EX [4] 14,20 x 8 x 44,0 IN/EX [4] 14,30 x 8 x 44,0 EX [4] 14,07 x 8 x 54,0 EX [4] 14,17 x 8 x 54,0 EX [4] 14,27 x 8 x 54,0	B1 CC B1 B1 B1 B1 B1 B1			11 12 1 259 934 11 12 1 338 708 11 12 1 259 935  11 12 1 250 268 11 12 1 255 295	<b>81-1153</b> <b>81-11109</b> <b>81-1154</b> <b>81-1155</b> <b>81-1150</b> <b>81-1151</b> <b>81-1152</b>
	(1) Kegelstückfixierung/cotter fixation/fijación de chavetas/fijación de chavetas/Крепление конического сухаря Ø 6 mm					

<b>30</b>		<b>82</b>						
<b>B48 A20 A</b>	03.2014 →	AB (A)	4	1998 cm <sup>3</sup>	4V	120-170 kW	(163-231 PS) 11	94,60 mm
<b>B48 A20 B Euro 6</b>	11.2013 →	AB (A)	4	1998 cm <sup>3</sup>	4V	141-195 kW	(192-265 PS) 11	94,60 mm
	IN [2] 30,1 x 5 x 99,2 EX [2] 28,5 x 6 x 99,8	S - - RA/S- Cr - Na		- 45° - - 45° -	- VS -	22 - III 22 - III	11 34 7 633 699 11 34 8 621 264	<b>111234</b> <small>NEW</small> <b>111233</b> <small>NEW</small>
[50]	Ø 6 mm						11 34 0 150 844 11 34 1 461 405	<b>MK-6H</b>

<b>31</b>		<b>82</b>						
<b>B48 B20 A</b>	07.2015 →	AB (A)	4	1998 cm <sup>3</sup>	4V	115-190 kW	(156-258 PS) 10,2	94,60 mm
	IN [2] 30,1 x 5 x 99,2 EX [2] 28,5 x 6 x 99,8	S - - RA/S- Cr - Na		- 45° - - 45° -	- VS -	22 - III 22 - III	11 34 7 633 699 11 34 8 621 264	<b>111234</b> <small>NEW</small> <b>111233</b> <small>NEW</small>
[50]	Ø 6 mm						11 34 0 150 844 11 34 1 461 405	<b>MK-6H</b>
	IN [6] 10,15 x 5 x 42,0 IN [1] 10,04 x 5 x 42,0 EX [6] 10,04 x 6 x 48,0 EX [6] 10,15 x 6 x 48,0	B1 B1 B1 B1						<b>81-11126</b> (1) <b>81-11125</b> <b>81-11127</b> <b>81-11128</b> (1)
	(1) 1. oversize							

<b>32</b>		<b>84</b>						
<b>M43 B16 (164E2)</b>	09.1993 → 08.2001	BG (NA)	4	1596 cm <sup>3</sup>	2V	75-77 kW	(102-105 PS) 9,7	72,00 mm
	IN [2] 42,0 x 7 x 104,0  EX [2] 36,0 x 7 x 103,0	S - - A/S - Cr -		- 45° - - 45° -	- VS -	22 - III 22 - III	11 34 1 433 892 11 34 1 739 114 11 34 1 739 658 11 34 1 433 893 11 34 1 739 665	<b>11673</b>  <b>11672</b>
[50]	Ø 7 mm						11 34 1 307 136	<b>MK-7H</b>
	IN/EX [6] 12,54 x 7 x 43,5 IN/EX [6] 12,55 x 7 x 43,5 IN/EX [6] 12,64 x 7 x 43,5 IN/EX [6] 12,73 x 7 x 43,5	B1 B1 B1 B1					11 12 1 715 373 11 12 1 715 373	<b>81-11101</b> <b>81-11110</b> <b>81-11102</b> <b>81-11111</b>
							11 31 1 739 176	<b>50 006 327</b> (1)
	(1) Schalenhartguss/chilled cast iron/pièce moulée trempée en surface/fundición en coquilla/Отливка с отбелсным поверхностным слоем							

Fortsetzung nächste Seite / continued on next page / suite page suivante / continuación página próxima / Продолжение на следующей странице



					Reference	Item No.
[8]	H 16 x 48,5				11 33 1 247 054 11 33 1 433 672 11 33 1 712 010 11 33 1 714 604 11 33 1 715 458 11 33 1 721 698	<b>50 006 476</b>

**33** **84**

<b>114/2</b>		B	4	1573 cm <sup>3</sup>	2V	77 kW	(105 PS)	9,5:1	71,00 mm
<b>116</b>		B	4	1573 cm <sup>3</sup>	2V	61-63 kW	(83-85 PS)	8,6	71,00 mm
<b>M10 B16 (164VA)</b>	08.1975 → 08.1980	B (NA)	4	1573 cm <sup>3</sup>	2V	55-77 kW	(75-105 PS)	8-9,5	71,00 mm
<b>M10 B16 (164VB)</b>	03.1981 → 03.1984	B (NA)	4	1573 cm <sup>3</sup>	2V	55-77 kW	(75-105 PS)	8-9,5	71,00 mm
<b>M10 B16 (16A)</b>	09.1963 → 12.1991	B (NA)	4	1573 cm <sup>3</sup>	2V	55-77 kW	(75-105 PS)	8-9,5	71,00 mm
<b>M10 B16 N</b>		B	4	1573 cm <sup>3</sup>	2V	55 kW	(75 PS)	8:1	71,00 mm
<b>M10 B16 V</b>		B	4	1573 cm <sup>3</sup>	2V	55 kW	(75 PS)	9,5:1	71,00 mm

IN [2]	42,0 x 8 x 103,8	S - -	- 45° - -	22 - III	11 34 1 251 879	<b>1195</b>
EX [2]	35,0 x 8 x 104,3	A/S - Cr -	- 45° - VS -	22 - III	11 34 1 251 498	<b>1198</b>
[50]	∅ 8 mm				11 34 1 710 975	<b>MK-8H</b>
IN/EX [4]	14,00 x 8 x 50,0	B1			11 12 1 263 642	<b>81-1162</b>
IN/EX [4]	14,10 x 8 x 50,0	B1			11 12 1 266 760	<b>81-1163</b>
IN/EX [4]	14,20 x 8 x 50,0	B1			11 12 1 266 761	<b>81-1164</b>

**34** **84**

<b>M20 B27 ME.U</b>	12.1984 → 12.1987	B	6	2693 cm <sup>3</sup>	2V	90 kW	(122 PS)	9:1	81,00 mm
<b>M20 B27 MEE</b>		B	6	2693 cm <sup>3</sup>	2V	92 kW	(125 PS)	10,2-11	81,00 mm

IN [2]	40,0 x 7 x 102,5	S - -	- 45° - -	22 - III	11 34 1 265 453 11 34 1 267 687 11 34 1 267 721	<b>1155</b> (1)
EX [2]	34,0 x 7 x 102,5	A/S - Cr -	- 45° - VS -	22 - III	11 34 1 267 722 11 34 1 280 643	<b>1156</b>
(1) für Kompressor/for compressor/pour compresseur/para compresor/для компрессора						
[50]	∅ 7 mm				11 34 1 307 136	<b>MK-7H</b>
IN/EX [6]	13,00 x 7 x 45,0	B1			11 12 1 280 523	<b>81-1158</b>
IN/EX [6]	13,14 x 7 x 45,0	B1			11 12 1 267 676	<b>81-1159</b>
IN/EX [6]	13,24 x 7 x 45,0	B1			11 12 1 267 677	<b>81-1160</b>
IN/EX [6]	13,34 x 7 x 45,0	B1			11 12 1 267 678	<b>81-1161</b>

**35** **84**

<b>M40 B18 (184E1)</b>	06.1987 → 06.1994	B (NA)	4	1796 cm <sup>3</sup>	2V	83-85 kW	(113-116 PS)	8,8	81,00 mm
<b>M40 B18 M.E</b>		B	4	1796 cm <sup>3</sup>	2V	83-85 kW	(113-115 PS)	8,8:1	81,00 mm

IN [2]	42,0 x 7 x 102,1	S - -	- 45° - -	22 - III	11 34 1 709 941 11 34 1 727 358	<b>11131</b>
EX [2]	35,9 x 7 x 101,1	A/S - Cr -	- 45° - VS -	22 - III	11 34 1 727 352	<b>111200</b>
[50]	∅ 7 mm				11 34 1 307 136	<b>MK-7H</b>
IN/EX [6]	12,54 x 7 x 43,5	B1			11 12 1 715 373	<b>81-11101</b>
IN/EX [6]	12,55 x 7 x 43,5	B1			11 12 1 715 373	<b>81-11110</b>
IN/EX [6]	12,64 x 7 x 43,5	B1				<b>81-11102</b>
IN/EX [6]	12,73 x 7 x 43,5	B1				<b>81-11111</b>
					11 31 1 709 580	<b>50 006 235</b> (1)
(1) Schalenhartguss/chilled cast iron/pièce moulée trempée en surface/fundición en coquilla/Отливка с отбеленным поверхностным слоем						

Fortsetzung nächste Seite / continued on next page / suite page suivante / continuación página próxima / Продолжение на следующей странице

					Reference	Item No.
[8]	H 16 x 48,5				11 33 1 247 054 11 33 1 433 672 11 33 1 712 010 11 33 1 714 604 11 33 1 715 458 11 33 1 721 698	50 006 476
FB [4]					11331709063	50 007 617

<b>36</b>		<b>84</b>							
<b>M40 B16 (164E1)</b>		09.1987 → 06.1994	B (NA)	4	1596 cm <sup>3</sup>	2V	73-75 kW	(99-102 PS)	9 72,00 mm
IN [2]	42,0 x 7 x 102,1	S	-	-	- 45°	-	22 - III	11 34 1 709 941 11 34 1 727 358	11131
EX [2]	35,9 x 7 x 101,1	A/S	-	Cr -	- 45°	VS -	22 - III	11 34 1 727 352	111200
[50]	Ø 7 mm							11 34 1 307 136	MK-7H
IN/EX [6]	12,54 x 7 x 43,5	B1						11 12 1 715 373	81-11101
IN/EX [6]	12,55 x 7 x 43,5	B1						11 12 1 715 373	81-11110
IN/EX [6]	12,64 x 7 x 43,5	B1							81-11102
IN/EX [6]	12,73 x 7 x 43,5	B1							81-11111
								11 31 1 709 580 11 31 1 739 176	50 006 235 (1) 50 006 327 (1)
	(1) Schalenhartguss/chilled cast iron/pièce moulée trempée en surface/fundición en coquilla/Отливка с отбеленным поверхностным слоем								
[8]	H 16 x 48,5							11 33 1 247 054 11 33 1 433 672 11 33 1 712 010 11 33 1 714 604 11 33 1 715 458 11 33 1 721 698	50 006 476
FB [4]								11331709063	50 007 617

<b>37</b>		<b>84</b>							
<b>M40 B18 C</b>			B (NA)	4	1796 cm <sup>3</sup>	2V	103 kW	(140 PS)	8,8 81,00 mm
<b>M70 B50 (5012A)</b>		09.1987 → 09.1994	B (NA)	12	4988 cm <sup>3</sup>	2V	220-230 kW	(300-313 PS)	8,8 75,00 mm
IN [2]	42,0 x 7 x 102,1	S	-	-	- 45°	-	22 - III	11 34 1 709 941 11 34 1 727 358	11131
EX [2]	35,9 x 7 x 101,1	A/S	-	Cr -	- 45°	VS -	22 - III	11 34 1 727 352	111200
[50]	Ø 7 mm							11 34 1 307 136	MK-7H
IN/EX [6]	12,54 x 7 x 43,5	B1						11 12 1 715 373	81-11101
IN/EX [6]	12,55 x 7 x 43,5	B1						11 12 1 715 373	81-11110
IN/EX [6]	12,64 x 7 x 43,5	B1							81-11102
IN/EX [6]	12,73 x 7 x 43,5	B1							81-11111
[8]	H 16 x 48,5							11 33 1 247 054 11 33 1 433 672 11 33 1 712 010 11 33 1 714 604 11 33 1 715 458 11 33 1 721 698	50 006 476
FB [4]								11331709063	50 007 617

					Reference	Item No.	
<b>38</b>		<b>84</b>					
<b>M42 B18 (184S1)</b>	09.1989 → 12.1995	B (NA)	4	1796 cm <sup>3</sup> 4V	100-103 kW (136-140 PS)	10 81,00 mm	
	IN [2]	33,0 x 6 x 106,1	S - -	- 45° - -	22 - III	11 34 1 438 284 11 34 1 438 385 11 34 1 438 451 11 34 1 738 218 11 34 1 739 820 11 34 1 739 822	<b>11960</b>
	EX [2]	30,5 x 6 x 105,7	A/S - Cr -	- 45° - VS -	22 - III	11 34 1 738 219 11 34 1 739 821 11 34 1 739 823	<b>11964</b>
	[50]	∅ 6 mm				11 34 0 150 844 11 34 1 461 405	<b>MK-6H</b>
	IN/EX [6]	12,53 x 6 x 43,5	B1			11 12 1 735 534	<b>81-11112</b> <b>81-11113</b>
	IN/EX [6]	12,73 x 6 x 43,5	B1				
	[8]	H 35 x 26				11 32 1 739 299	<b>50 006 475</b>
<b>39</b>		<b>84</b>					
<b>M60 B30 (308S1)</b>	04.1992 → 11.2001	B (NA)	8	2997 cm <sup>3</sup> 4V	155-160 kW (211-218 PS)	10,5 67,60 mm	
<b>M62 B35 (358S1)</b>	03.1996 → 08.1998	B (NA)	8	3498 cm <sup>3</sup> 4V	173 kW (235 PS)	10 78,90 mm	
<b>M62 B35 (358S2)</b>	09.1998 → 06.2003	B (NA)	8	3498 cm <sup>3</sup> 4V	173-180 kW (235-245 PS)	10 78,90 mm	
<b>M62 B35 TU</b>	03.1996 → 09.2001	B (NA)	8	3498 cm <sup>3</sup> 4V	175-180 kW (238-245 PS)	10:1 78,90 mm	
	IN/EX [6]	12,53 x 6 x 43,5	B1			11 12 1 735 534	<b>81-11112</b> <b>81-11113</b>
	IN/EX [6]	12,73 x 6 x 43,5	B1				
<b>40</b>		<b>84</b>					
<b>M52 B25 (256S3)</b>	05.1995 → 12.2002	B (NA)	6	2494 cm <sup>3</sup> 4V	120-141 kW (163-192 PS)	10,2-10,5 75,00 mm	
<b>M52 B25 (256S4)</b>	03.1998 → 12.2002	B (NA)	6	2494 cm <sup>3</sup> 4V	120-141 kW (163-192 PS)	10,2-10,5 75,00 mm	
<b>M52 B28 (286S1)</b>	01.1995 → 11.2001	B (NA)	6	2793 cm <sup>3</sup> 4V	141-143 kW (192-194 PS)	10,2 84,00 mm	
<b>M52 B28 (286S2)</b>	08.1995 → 11.2001	B (NA)	6	2793 cm <sup>3</sup> 4V	141-144 kW (192-196 PS)	10,2 84,00 mm	
<b>M54 256 S3</b>		B	6	2494 cm <sup>3</sup> 4V	141 kW (192 PS)	10,5:1 75,00 mm	
<b>M54 B25 (256S5)</b>	01.1999 → 12.2010	B (NA)	6	2494 cm <sup>3</sup> 4V	137-141 kW (186-192 PS)	10,5 75,00 mm	
<b>M54 B30 (306S3)</b>	04.2000 → 07.2008	B (NA)	6	2979 cm <sup>3</sup> 4V	163-170 kW (222-231 PS)	10,2 89,60 mm	
40 303 6..							
	IN [2]	33,0 x 6 x 106,1	S - -	- 45° - -	22 - III	11 34 1 438 284 11 34 1 438 385 11 34 1 438 451 11 34 1 738 218 11 34 1 739 820 11 34 1 739 822	<b>11960</b>
	EX [2]	30,5 x 6 x 105,7	A/S - Cr -	- 45° - VS -	22 - III	11 34 1 738 219 11 34 1 739 821 11 34 1 739 823	<b>11964</b>
	[50]	∅ 6 mm				11 34 0 150 844 11 34 1 461 405	<b>MK-6H</b>
	IN/EX [6]	12,53 x 6 x 43,5	B1			11 12 1 735 534	<b>81-11112</b> <b>81-11113</b>
	IN/EX [6]	12,73 x 6 x 43,5	B1				
	[8]	H 33 x 24 x 24				11 32 1 748 880 11 32 1 748 881 11 32 1 748 882 11 32 1 748 884	<b>50 006 409</b>
<b>41</b>		<b>84</b>					
<b>M43 B16 (164E3)</b>	11.1998 → 07.2006	B (NA)	4	1596 cm <sup>3</sup> 2V	77 kW (105 PS)	9,7 72,00 mm	

Fortsetzung nächste Seite / continued on next page / suite page suivante / continuación página próxima / Продолжение на следующей странице

					Reference	Item No.	
	IN [2] EX [2]	42,0 x 7 x 104,0 36,0 x 7 x 103,0	S - - A/S - Cr -	- 45° - - - 45° - VS -	22 - III 22 - III	11 34 1 433 892 11 34 1 739 114 11 34 1 739 658 11 34 1 433 893 11 34 1 739 665	<b>11673</b> <b>11672</b>
	[50]	Ø 7 mm				11 34 1 307 136	<b>MK-7H</b>
	IN/EX [6] IN/EX [6] IN/EX [6] IN/EX [6]	12,54 x 7 x 43,5 12,55 x 7 x 43,5 12,64 x 7 x 43,5 12,73 x 7 x 43,5	B1 B1 B1 B1			11 12 1 715 373 11 12 1 715 373	<b>81-11101</b> <b>81-11110</b> <b>81-11102</b> <b>81-11111</b>
						11 31 1 739 176	<b>50 006 327</b> (1)
							(1) Schalenhartguss/chilled cast iron/pièce moulée trempée en surface/fundición en coquilla/Отливка с отбеленным поверхностным слоем
	[8]	H 16 x 48,5				11 33 1 247 054 11 33 1 433 672 11 33 1 712 010 11 33 1 714 604 11 33 1 715 458 11 33 1 721 698	<b>50 006 476</b>

**42**

**84**

<b>N42 B18 A</b>	06.2001 → 02.2005	B (NA)	4	1796 cm <sup>3</sup>	4V	85 kW	(115 PS)	10,5	81,00 mm
<b>N42 B20 A</b>	12.2000 → 12.2007	B (NA)	4	1995 cm <sup>3</sup>	4V	100-110 kW	(136-150 PS)	10,5	90,00 mm
<b>N42 B20 B</b>		B	4	1995 cm <sup>3</sup>	4V	95 kW	(129 PS)	10,5:1	90,00 mm
<b>N42 B20 BZ</b>		B	4	1995 cm <sup>3</sup>	4V			9:1	90,00 mm
<b>N46 B18 A</b>	06.2001 → 02.2005	B (NA)	4	1796 cm <sup>3</sup>	4V	85 kW	(115 PS)	10,25	81,00 mm
<b>N46 B20 A</b>	12.2000 → 06.2011	B (NA)	4	1995 cm <sup>3</sup>	4V	95-125 kW	(129-170 PS)	10,5	90,00 mm
<b>N46 B20 B</b>	06.2004 → 06.2015	B (NA)	4	1995 cm <sup>3</sup>	4V	95-125 kW	(129-170 PS)	10,5	90,00 mm
<b>N46 B20 BD</b>	06.2004 → 06.2015	B (NA)	4	1995 cm <sup>3</sup>	4V	95-125 kW	(129-170 PS)	10,5	90,00 mm
<b>N46 B20 CC</b>	06.2004 → 06.2015	B (NA)	4	1995 cm <sup>3</sup>	4V	95-125 kW	(129-170 PS)	10,5	90,00 mm
<b>N46 B20 CD</b>	02.2007 → 06.2015	B (NA)	4	1995 cm <sup>3</sup>	4V	95-125 kW	(129-170 PS)	10,5	90,00 mm
<b>N46 B20 E</b>	02.2007 → 06.2015	B (NA)	4	1995 cm <sup>3</sup>	4V	95-125 kW	(129-170 PS)	10,5	90,00 mm
<b>N46 B20 LC</b>		B	4	1995 cm <sup>3</sup>	4V	105 kW	(143 PS)	9:1	90,00 mm
<b>N46 B20 TU2</b>		B	4	1995 cm <sup>3</sup>	4V	100-115 kW	(136-156 PS)	10,5:1	90,00 mm

40 085 6..., 40 086 6..., 40 087 6...

	IN [2] EX [2]	32,0 x 6 x 100,0 29,0 x 6 x 100,1	S - Cr - RA/S- Cr -	- 45° - - - 45° - VS -	22 - III 22 - III	11 34 1 440 304 11 34 1 707 519 11 34 4 457 287 11 34 7 503 738 11 34 7 529 839	<b>111210</b> <b>111209</b>
	[50]	Ø 6 mm				11 34 0 150 844 11 34 1 461 405	<b>MK-6H</b>
	IN/EX [6] IN/EX [4]	10,02 x 6.01 x 39,0 10,15 x 6.01 x 39,0	B1 B1				<b>81-11117</b> <b>81-11118</b> <small>NEW</small> (1)
	(1)	1. oversize					
	[8]	H 12 x 34,5				11 33 1 707 712 11 33 7 512 116	<b>50 006 493</b>

**43**

**84**

<b>N40 B16 A</b>	06.2002 → 02.2005	B (NA)	4	1596 cm <sup>3</sup>	4V	77-85 kW	(105-115 PS)	10,2	72,00 mm
------------------	-------------------	--------	---	----------------------	----	----------	--------------	------	----------

40 086 6...

Fortsetzung nächste Seite / continued on next page / suite page suivante / continuación página próxima / Продолжение на следующей странице



**B**

						Reference	Item No.
	IN [2] 35,0 x 6 x 100,0	S - Cr -	- 45° - -	22 - III		11 34 1 435 461 11 34 7 503 737 11 34 7 541 555	<b>111208</b>
	EX [2] 29,0 x 6 x 100,1	RA/S- Cr -	- 45° - VS -	22 - III		11 34 1 707 519 11 34 4 457 287 11 34 7 503 738 11 34 7 529 839	<b>111209</b>
	[50] Ø 6 mm					11 34 0 150 844 11 34 1 461 405	<b>MK-6H</b>
	IN/EX [6] 10,02 x 6.01 x 39,0 IN/EX [4] 10,15 x 6.01 x 39,0  (1) 1. oversize	B1 B1					<b>81-11117</b> <b>81-11118</b> <small>NEW</small> (1)
	ES  (2) Schalenhartguss/chilled cast iron/pièce moulée trempée en surface/fundición en coquilla/Отливка с отбелнным поверхностным слоем					11 31 7 500 935 11 31 7 500 938 11 31 7 507 994	<b>50 007 639</b> (2) <b>50 007 684</b> (2)
	[8] H 12 x 34,5					11 33 1 707 712 11 33 7 512 116	<b>50 006 493</b>

**44** **84**
**N45 B16 A** 06.2002 → 12.2011 B (NA) 4 1596 cm<sup>3</sup> 4V 85 kW (115 PS) 10,2 72,00 mm  
 40 086 6..

	IN [2] 35,0 x 6 x 100,0	S - Cr -	- 45° - -	22 - III		11 34 1 435 461 11 34 7 503 737 11 34 7 541 555	<b>111208</b>
	EX [2] 29,0 x 6 x 100,1	RA/S- Cr -	- 45° - VS -	22 - III		11 34 1 707 519 11 34 4 457 287 11 34 7 503 738 11 34 7 529 839	<b>111209</b>
	[50] Ø 6 mm					11 34 0 150 844 11 34 1 461 405	<b>MK-6H</b>
	IN/EX [6] 10,02 x 6.01 x 39,0 IN/EX [4] 10,15 x 6.01 x 39,0  (1) 1. oversize	B1 B1					<b>81-11117</b> <b>81-11118</b> <small>NEW</small> (1)
	ES  (2) Schalenhartguss/chilled cast iron/pièce moulée trempée en surface/fundición en coquilla/Отливка с отбелнным поверхностным слоем					11 31 7 500 935	<b>50 007 639</b> (2)
	[8] H 12 x 34,5					11 33 1 707 712 11 33 7 512 116	<b>50 006 493</b>

**45** **84**
**N46 B20 C** 03.2004 → 06.2015 B (NA) 4 1995 cm<sup>3</sup> 4V 95-125 kW (129-170 PS) 10,5 90,00 mm  
**N46 B20 TU2 UL** B 4 1995 cm<sup>3</sup> 4V 100 kW (136 PS) 10,5:1 90,00 mm

	IN [2] 31,4 x 6 x 106,7	S - -	- 45° - -	22 - III		11 34 7 548 280	<b>111213</b>
	IN [2] 32,0 x 6 x 100,0	S - Cr -	- 45° - -	22 - III		11 34 1 440 304	<b>111210</b>
	EX [2] 28,0 x 6 x 114,6	RA/S- Cr -	- 45° - VS -	22 - III		11 34 7 573 840	<b>111214</b>
	EX [2] 29,0 x 6 x 100,1	RA/S- Cr -	- 45° - VS -	22 - III		11 34 1 707 519 11 34 4 457 287 11 34 7 503 738 11 34 7 529 839	<b>111209</b>

Fortsetzung nächste Seite / continued on next page / suite page suivante / continuación página próxima / Продолжение на следующей странице

					Reference	Item No.
[50]	Ø 6 mm				11 34 0 150 844 11 34 1 461 405	<b>MK-6H</b>
IN/EX [6] IN/EX [4] (1) 1. oversize	10,02 x 6.01 x 39,0 10,15 x 6.01 x 39,0	B1 B1				<b>81-11117</b> <b>81-11118</b> <small>NEW</small> (1)
[8]	H 12 x 34,5				11 33 1 707 712 11 33 7 512 116	<b>50 006 493</b>

<b>46</b>		<b>84</b>							
<b>N20 B20</b>	10.2009 →	B (LA) 4	1997 cm <sup>3</sup>	4V	135-180 kW	(184-245 PS)	11,0:1	90,10 mm	
<b>N20 B20 B</b>	10.2010 →	B (A) 4	1997 cm <sup>3</sup>	4V	120-135 kW	(163-184 PS)	10-11	90,10 mm	
<b>N20 B20 C</b>	07.2012 →	B (LA) 4	1997 cm <sup>3</sup>	4V	135 kW	(184 PS)	11,0:1	90,10 mm	
<b>N20 B20 D</b>	03.2012 → 10.2018	B (A) 4	1997 cm <sup>3</sup>	4V	135 kW	(184 PS)	10	90,10 mm	
<b>N55 B30 A</b>	03.2006 →	B (A) 6	2979 cm <sup>3</sup>	4V	200-272 kW	(272-370 PS)	10,2	89,60 mm	
41 991 6..									

IN [2]	32,0 x 5 x 104,9	S - -	- 45° - -	22 - III	11 34 7 583 777 11 34 7 583 779	<b>111223</b>
EX [2]	28,0 x 6 x 112,9	RA/S- -	- 45° - VS -	22 - III	11 34 7 583 780 11 34 7 598 273	<b>111225</b>
[50] [50]	Ø 5 mm Ø 6 mm				11 34 0 150 844 11 34 1 461 405	<b>MK-5H</b> <b>MK-6H</b>
IN [6] IN [1] EX [6] EX [6] (1) 1. oversize	10,15 x 5 x 42,0 10,04 x 5 x 42,0 10,04 x 6 x 48,0 10,15 x 6 x 48,0	B1 B1 B1 B1				<b>81-11126</b> (1) <b>81-11125</b> <b>81-11127</b> <b>81-11128</b> (1)
[8]	H 12 x 34,5				11 33 7 546 466 11 33 7 548 690	<b>50 006 492</b>
[4]					11 33 7 559 797	<b>50 006 129</b>

<b>47</b>		<b>84</b>							
<b>N54 B30 A</b>	03.2006 → 08.2016	B (A) 6	2979 cm <sup>3</sup>	4V	200-264 kW	(272-359 PS)	10,2	89,60 mm	
<b>N54 B30 B</b>		B (LA) 6	2979 cm <sup>3</sup>	4V	225 kW	(306 PS)	10,2	89,60 mm	
<b>N54 B30 TO</b>		B (LA) 6	2979 cm <sup>3</sup>	4V	240 kW	(326 PS)	10,2:1	89,60 mm	
<b>N54 B30 UO</b>		B (LA) 6	2979 cm <sup>3</sup>	4V	225 kW	(306 PS)	10,2:1	89,60 mm	

IN [2]	31,4 x 5 x 106,6	S - -	- 45° - -	22 - III	11 34 7 553 775	<b>111222</b>
EX [2]	28,0 x 6 x 114,6	RA/S- Cr -	- 45° - VS -	22 - III	11 34 7 573 840	<b>111214</b>
[50] [50]	Ø 5 mm Ø 6 mm				11 34 0 150 844 11 34 1 461 405	<b>MK-5H</b> <b>MK-6H</b>
IN [6] IN [1] EX [6] EX [6] (1) 1. oversize	10,15 x 5 x 42,0 10,04 x 5 x 42,0 10,04 x 6 x 48,0 10,15 x 6 x 48,0	B1 B1 B1 B1				<b>81-11126</b> (1) <b>81-11125</b> <b>81-11127</b> <b>81-11128</b> (1)
[8]	H 12 x 34,5				11 33 7 546 466 11 33 7 548 690	<b>50 006 492</b>
[4]					11 33 7 559 797	<b>50 006 129</b>

					Reference	Item No.
<b>48</b> <b>84</b>						
<b>N43 B20 A</b> 40 420 6..	09.2006 →	B (NA)	4	1995 cm <sup>3</sup> 4V	90-125 kW (122-170 PS) 12:1	90,00 mm
IN [2] EX [2]	31,4 x 6 x 106,7 28,0 x 6 x 114,6	S - - RA/S- Cr -	- 45° - - - 45° - VS -	22 - III 22 - III	11 34 7 548 280 11 34 7 573 840	<b>111213</b> <b>111214</b>
[50]	Ø 6 mm				11 34 0 150 844 11 34 1 461 405	<b>MK-6H</b>
IN/EX [6] IN/EX [6]	12,53 x 6 x 43,5 12,73 x 6 x 43,5	B1 B1			11 12 1 735 534	<b>81-11112</b> <b>81-11113</b>
[8]	H 12 x 34,5				11 33 7 546 466 11 33 7 548 690	<b>50 006 492</b>
[4]					11 33 7 542 421	<b>50 006 128</b>
<b>49</b> <b>84</b>						
<b>N26 B20 A Euro 6</b>	03.2012 →	B (A)	4	1997 cm <sup>3</sup> 4V	179-180 kW (243-245 PS) 10	90,10 mm
IN [2] EX [2]	32,0 x 5 x 104,9 28,0 x 6 x 112,9	S - - RA/S- -	- 45° - - - 45° - VS -	22 - III 22 - III	11 34 7 583 777 11 34 7 583 779 11 34 7 583 780 11 34 7 598 273	<b>111223</b> <b>111225</b>
<b>50</b> <b>84</b>						
<b>M20 B25 M.E</b> <b>M20 B25 M.E/8</b> <b>M20 B25 M1.Z7</b>		B B B	6 6 6	2494 cm <sup>3</sup> 2V 2494 cm <sup>3</sup> 2V 2494 cm <sup>3</sup> 2V	125 kW (170 PS) 9,4:1 125 kW (170 PS) 9,4:1 125 kW (170 PS) 8,8:1	75,00 mm 75,00 mm 75,00 mm
IN [2] EX [2]	42,0 x 7 x 102,5 36,0 x 7 x 102,5	S - - A/S - Cr -	- 45° - - - 45° - VS -	22 - III 22 - III	11 34 1 708 895 11 34 1 720 827 11 34 1 287 814 11 34 1 708 896 11 34 1 720 828	<b>11104</b> <b>11129</b>
[50]	Ø 7 mm				11 34 1 307 136	<b>MK-7H</b>
IN/EX [6] IN/EX [6] IN/EX [6] IN/EX [6]	13,00 x 7 x 45,0 13,14 x 7 x 45,0 13,24 x 7 x 45,0 13,34 x 7 x 45,0	B1 B1 B1 B1			11 12 1 280 523 11 12 1 267 676 11 12 1 267 677 11 12 1 267 678	<b>81-1158</b> <b>81-1159</b> <b>81-1160</b> <b>81-1161</b>
					11 31 1 716 138	<b>50 006 239</b> (1)
	(1) Schalenhartguss/chilled cast iron/pièce moulée trempée en surface/fundición en coquilla/Отливка с отбелсным поверхностным слоем					
<b>51</b> <b>84</b>						
<b>M40 B16 C</b>		B (NA)	4	1596 cm <sup>3</sup> 2V	73-75 kW (99-102 PS) 9:1	72,00 mm
IN [2] EX [2]	33,0 x 7 x 106,7 30,5 x 7 x 106,3	S - - A/S - Cr -	- 45° - - - 45° - VS -	22 - III 22 - III	11 34 1 722 892 11 34 1 722 908 11 34 1 722 891 11 34 1 722 893 11 34 1 722 909 11 34 1 726 903 11 34 1 727 151	<b>11359</b> <b>11360</b>
[50]	Ø 7 mm				11 34 1 307 136	<b>MK-7H</b>
Fortsetzung nächste Seite / continued on next page / suite page suivante / continuación página próxima / Продолжение на следующей странице						

					Reference	Item No.
	IN/EX [6] 12,54 x 7 x 43,5 IN/EX [6] 12,55 x 7 x 43,5 IN/EX [6] 12,64 x 7 x 43,5 IN/EX [6] 12,73 x 7 x 43,5	B1 B1 B1 B1			11 12 1 715 373 11 12 1 715 373	<b>81-11101</b> <b>81-11110</b> <b>81-11102</b> <b>81-11111</b>
	[8] H 16 x 48,5				11 33 1 247 054 11 33 1 433 672 11 33 1 712 010 11 33 1 714 604 11 33 1 715 458 11 33 1 721 698	<b>50 006 476</b>

<b>52</b> <b>84</b>						
<b>M42 B18 TU1</b>						
		B	4	1796 cm <sup>3</sup> 4V	103 kW (140 PS) 10:1	81,00 mm
	IN [2] 33,0 x 6 x 106,1	S - -	- 45° - -	22 - III	11 34 1 438 284 11 34 1 438 385 11 34 1 438 451 11 34 1 738 218 11 34 1 739 820 11 34 1 739 822	<b>11960</b>
	EX [2] 30,5 x 6 x 105,7	A/S - Cr -	- 45° - VS -	22 - III	11 34 1 738 219 11 34 1 739 821 11 34 1 739 823	<b>11964</b>
	[50] Ø 6 mm				11 34 0 150 844 11 34 1 461 405	<b>MK-6H</b>
	IN/EX [6] 12,53 x 6 x 43,5 IN/EX [6] 12,73 x 6 x 43,5	B1 B1			11 12 1 735 534	<b>81-11112</b> <b>81-11113</b>

<b>53</b> <b>84</b>						
<b>M50 B25 M</b>						
		B	6	2494 cm <sup>3</sup> 4V	141 kW (192 PS) 10:1	75,00 mm
	IN [2] 33,0 x 6 x 106,1	S - -	- 45° - -	22 - III	11 34 1 438 284 11 34 1 438 385 11 34 1 438 451 11 34 1 738 218 11 34 1 739 820 11 34 1 739 822	<b>11960</b>
	IN [2] 33,0 x 7 x 106,7	S - -	- 45° - -	22 - III	11 34 1 722 892 11 34 1 722 908	<b>11359</b>
	EX [2] 30,5 x 6 x 105,7	A/S - Cr -	- 45° - VS -	22 - III	11 34 1 738 219 11 34 1 739 821 11 34 1 739 823	<b>11964</b>
	EX [2] 30,5 x 7 x 106,3	A/S - Cr -	- 45° - VS -	22 - III	11 34 1 722 891 11 34 1 722 893 11 34 1 722 909 11 34 1 726 903 11 34 1 727 151	<b>11360</b>
	[50] Ø 6 mm				11 34 0 150 844 11 34 1 461 405	<b>MK-6H</b>
	[50] Ø 7 mm				11 34 1 307 136	<b>MK-7H</b>
	IN/EX [6] 12,53 x 6 x 43,5 IN/EX [6] 12,54 x 7 x 43,5 IN/EX [6] 12,55 x 7 x 43,5 IN/EX [6] 12,64 x 7 x 43,5 IN/EX [6] 12,73 x 6 x 43,5 IN/EX [6] 12,73 x 7 x 43,5	B1 B1 B1 B1 B1 B1			11 12 1 735 534 11 12 1 715 373 11 12 1 715 373	<b>81-11112</b> <b>81-11101</b> <b>81-11110</b> <b>81-11102</b> <b>81-11113</b> <b>81-11111</b>
	[8] H 33 x 24 x 24				11 32 1 748 880 11 32 1 748 881 11 32 1 748 882 11 32 1 748 884	<b>50 006 409</b>
	[8] H 35 x 26				11 32 1 739 299	<b>50 006 475</b>



					Reference	Item No.	
<b>54</b>	<b>84</b>	<b>N45 B16 TU2</b>					
		B (NA)	4	1596 cm <sup>3</sup> 4V	85-90 kW (115-122 PS) 10,2:1	72,00 mm	
	IN [2]	35,0 x 6 x 100,0	S - Cr -	- 45° - -	22 - III	11 34 1 435 461 11 34 7 503 737 11 34 7 541 555	<b>111208</b>
	EX [2]	29,0 x 6 x 100,1	RA/S- Cr -	- 45° - VS -	22 - III	11 34 1 707 519 11 34 4 457 287 11 34 7 503 738 11 34 7 529 839	<b>111209</b>
	[50]	∅ 6 mm				11 34 0 150 844 11 34 1 461 405	<b>MK-6H</b>
	IN/EX [6]	10,02 x 6.01 x 39,0	B1				<b>81-11117</b>
	IN/EX [4]	10,15 x 6.01 x 39,0	B1				<b>81-11118</b> <small>NEW</small> (1)
	(1)	1. oversize					
	[8]	H 12 x 34,5				11 33 1 707 712 11 33 7 512 116	<b>50 006 493</b>
<b>55</b>	<b>84</b>	<b>N45 B16 TU2 OL</b>					
		B	4	1596 cm <sup>3</sup> 4V	85 kW (116 PS) 10,25:1	72,00 mm	
	IN [2]	35,0 x 6 x 100,0	S - Cr -	- 45° - -	22 - III	11 34 1 435 461 11 34 7 503 737 11 34 7 541 555	<b>111208</b>
	EX [2]	29,0 x 6 x 100,1	RA/S- Cr -	- 45° - VS -	22 - III	11 34 1 707 519 11 34 4 457 287 11 34 7 503 738 11 34 7 529 839	<b>111209</b>
	[50]	∅ 6 mm				11 34 0 150 844 11 34 1 461 405	<b>MK-6H</b>
	IN/EX [6]	10,02 x 6.01 x 39,0	B1				<b>81-11117</b>
	IN/EX [4]	10,15 x 6.01 x 39,0	B1				<b>81-11118</b> <small>NEW</small> (1)
	(1)	1. oversize					
	[8]	H 12 x 34,5				11 33 7 546 466 11 33 7 548 690	<b>50 006 492</b>
	[8]	H 12 x 34,5				11 33 1 707 712 11 33 7 512 116	<b>50 006 493</b>
<b>56</b>	<b>84</b>	<b>M43 B18 (184E2) KAT</b>					
		09.1993 → 11.1999	AB (NA)	4	1796 cm <sup>3</sup> 2V	83-85 kW (113-116 PS) 9,7	81,00 mm
		94 493 6..					
	IN [2]	42,0 x 7 x 104,0	S - -	- 45° - -	22 - III	11 34 1 433 892 11 34 1 739 114 11 34 1 739 658	<b>11673</b>
	EX [2]	36,0 x 7 x 103,0	A/S - Cr -	- 45° - VS -	22 - III	11 34 1 433 893 11 34 1 739 665	<b>11672</b>
	[50]	∅ 7 mm				11 34 1 307 136	<b>MK-7H</b>
	IN/EX [6]	12,54 x 7 x 43,5	B1			11 12 1 715 373	<b>81-11101</b>
	IN/EX [6]	12,55 x 7 x 43,5	B1			11 12 1 715 373	<b>81-11110</b>
	IN/EX [6]	12,64 x 7 x 43,5	B1				<b>81-11102</b>
	IN/EX [6]	12,73 x 7 x 43,5	B1				<b>81-11111</b>
						11 31 1 739 176	<b>50 006 327</b> (1)

Fortsetzung nächste Seite / continued on next page / suite page suivante / continuación página próxima / Продолжение на следующей странице

					Reference	Item No.	
(1)	Schalenhartguss/chilled cast iron/pièce moulée trempée en surface/fundición en coquilla/Отливка с отбеленным поверхностным слоем						
[8]	H 16 x 48,5				11 33 1 247 054 11 33 1 433 672 11 33 1 712 010 11 33 1 714 604 11 33 1 715 458 11 33 1 721 698	<b>50 006 476</b>	

<b>57</b>		<b>84</b>						
<b>N20 B20 A</b>	10.2009 →	AB (A)	4	1997 cm <sup>3</sup>	4V	110-205 kW	(150-279 PS) 10	90,10 mm
41 990 6..								

IN [2]	32,0 x 5 x 104,9	S - -	- 45° - -	22 - III	11 34 7 583 777 11 34 7 583 779	<b>111223</b>
EX [2]	28,0 x 6 x 112,9	RA/S- -	- 45° - VS -	22 - III	11 34 7 583 780 11 34 7 598 273	<b>111225</b>
[50]	∅ 5 mm					<b>MK-5H</b>
[50]	∅ 6 mm				11 34 0 150 844 11 34 1 461 405	<b>MK-6H</b>
IN [6]	10,15 x 5 x 42,0	B1				<b>81-11126</b> (1)
IN [1]	10,04 x 5 x 42,0	B1				<b>81-11125</b>
EX [6]	10,04 x 6 x 48,0	B1				<b>81-11127</b>
EX [6]	10,15 x 6 x 48,0	B1				<b>81-11128</b> (1)
(1) 1. oversize						
[8]	H 12 x 34,5				11 33 7 546 466 11 33 7 548 690	<b>50 006 492</b>
[4]					11 33 7 559 797	<b>50 006 129</b>

<b>58</b>		<b>84</b>						
<b>M43 B18 Gas KAT</b>	09.1993 → 04.1999	GF	4	1796 cm <sup>3</sup>	2V	85 kW	(115 PS) 9,7:1	81,00 mm

IN [2]	42,0 x 7 x 104,0	S - -	- 45° - -	22 - III	11 34 1 433 892 11 34 1 739 114 11 34 1 739 658	<b>11673</b>
EX [2]	36,0 x 7 x 103,0	A/S - Cr -	- 45° - VS -	22 - III	11 34 1 433 893 11 34 1 739 665	<b>11672</b>
[50]	∅ 7 mm				11 34 1 307 136	<b>MK-7H</b>
IN/EX [6]	12,54 x 7 x 43,5	B1			11 12 1 715 373	<b>81-11101</b>
IN/EX [6]	12,55 x 7 x 43,5	B1			11 12 1 715 373	<b>81-11110</b>
IN/EX [6]	12,64 x 7 x 43,5	B1				<b>81-11102</b>
IN/EX [6]	12,73 x 7 x 43,5	B1				<b>81-11111</b>
					11 31 1 739 176	<b>50 006 327</b> (1)
(1) Schalenhartguss/chilled cast iron/pièce moulée trempée en surface/fundición en coquilla/Отливка с отбеленным поверхностным слоем						
[8]	H 16 x 48,5				11 33 1 247 054 11 33 1 433 672 11 33 1 712 010 11 33 1 714 604 11 33 1 715 458 11 33 1 721 698	<b>50 006 476</b>

					Reference	Item No.		
<b>59</b>		<b>84</b>						
<b>M47 D20 (204D1)</b>	02.1998 → 09.2003	D (A)	4	1951 cm <sup>3</sup>	4V	85-100 kW (116-136 PS)	19	88,00 mm
<b>M47 D20 (204D4)</b>	09.2001 → 05.2010	D (A)	4	1995 cm <sup>3</sup>	4V	85-120 kW (116-163 PS)	17	90,00 mm
<b>M47 D20 OL</b>		D (LA)	4	1951 cm <sup>3</sup>	4V	100 kW (136 PS)	19:1	88,00 mm
<b>M47 D20 TU2</b>		D (LA)	4	1951 cm <sup>3</sup>	4V	90-120 kW (122-163 PS)	19,0:1	88,00 mm
<b>M47 D20 TU2 OL</b>		D (LA)	4	1995 cm <sup>3</sup>	4V	120 kW (163 PS)	17:1	90,00 mm
<b>M47 D20 TU2 UL</b>	09.2008 → 05.2011	D (LA)	4	1995 cm <sup>3</sup>	4V	105 kW (143 PS)	16:1	90,00 mm
<b>Euro 5</b>								
<b>M47 D20 TU2 UL</b>	09.2004 → 03.2007	D (LA)	4	1995 cm <sup>3</sup>	4V	90 kW (122 PS)	17:1	90,00 mm
<b>Euro 4</b>								
<b>M47 D20 UL Euro 3</b>		D (LA)	4	1951 cm <sup>3</sup>	4V	85 kW (115 PS)	19:1	88,00 mm
<b>M47 D20 UL</b>		D (LA)	4	1995 cm <sup>3</sup>	4V	85 kW (115 PS)	17:1	90,00 mm
<b>M47 D20TU OL</b>		D (LA)	4	1951 cm <sup>3</sup>	4V	100 kW (136 PS)	19:1	88,00 mm
<b>M47 D20TU UL</b>		D (LA)	4	1951 cm <sup>3</sup>	4V	85 kW (115 PS)	19:1	88,00 mm
<b>M47 D20TU2 OL</b>		D (LA)	4	1951 cm <sup>3</sup>	4V	110-120 kW (150-163 PS)	17:1	88,00 mm
<b>M57 306 D4</b>		D (LA)	6	2993 cm <sup>3</sup>	4V	200 kW (272 PS)	16,5:1	90,00 mm
<b>M57 D25 TU</b>		D (LA)	6	2497 cm <sup>3</sup>	4V	130 kW (177 PS)	17:1	82,80 mm
<b>M57 D30 (135 kW)</b>		D (LA)	6	2926 cm <sup>3</sup>	4V	135-142 kW (184-193 PS)	18:1	88,00 mm
<b>M57 D30 (306D1)</b>	08.1998 → 02.2005	D (A)	6	2926 cm <sup>3</sup>	4V	135-142 kW (184-193 PS)	17	88,00 mm
<b>M57 D30 TU2 OL</b>		D (LA)	6	2993 cm <sup>3</sup>	4V	173 kW (235 PS)	17:1	90,00 mm
<b>M57 D30 UL</b>		D (LA)	6	2993 cm <sup>3</sup>	4V	145 kW (197 PS)	17:1	90,00 mm
<b>M67 D39 (398D1)</b>	05.1999 → 02.2005	D (A)	8	3901 cm <sup>3</sup>	4V	180-190 kW (245-258 PS)	18	88,00 mm
	IN/EX [2]	25,9 x 6 x 99,9	RA/S- Cr -	- 45° - VS -	22 - III	11 34 2 247 077		<b>111113</b>
	[50]	∅ 6 mm				11 34 0 150 844 11 34 1 461 405		<b>MK-6H</b>
	IN/EX [6]	11,54 x 6 x 39,0	B1					<b>81-11116</b>
	[8]	H 12 x 34,5 x 34,5				11 33 2 247 722 11 33 2 249 817		<b>50 006 414</b>
	[4]					11 12 2 247 056 11 33 2 248 878		<b>50 006 132</b>
<b>60</b>		<b>84</b>						
<b>M57 D30 (306D2)</b>	06.2002 → 05.2010	D (A)	6	2993 cm <sup>3</sup>	4V	150-160 kW (204-218 PS)	17	90,00 mm
<b>M57 D30 (306D3)</b>	09.2002 → 12.2013	D (A)	6	2993 cm <sup>3</sup>	4V	135-173 kW (184-235 PS)	17	90,00 mm
<b>M57 D30 (306D4)</b>	09.2004 → 12.2011	D (A)	6	2993 cm <sup>3</sup>	4V	198-200 kW (269-272 PS)	16,5	90,00 mm
<b>M57 D30 (306D5)</b>	03.2006 → 07.2013	D (A)	6	2993 cm <sup>3</sup>	4V	198-221 kW (269-301 PS)	16,5	90,00 mm
<b>M57 D30 N2</b>	09.2006 → 05.2010	D (LA)	6	2993 cm <sup>3</sup>	4V	173-210 kW (231-286 PS)	17:1	90,00 mm
<b>M57 D30 TU</b>	04.2005 → 09.2005	D (LA)	6	2993 cm <sup>3</sup>	4V	150-160 kW (204-218 PS)	17:1	90,00 mm
	IN/EX [2]	25,9 x 6 x 99,9	RA/S- Cr -	- 45° - VS -	22 - III	11 34 2 247 077		<b>111113</b>
	[50]	∅ 6 mm				11 34 0 150 844 11 34 1 461 405		<b>MK-6H</b>
	IN/EX [6]	11,54 x 6 x 39,0	B1					<b>81-11116</b>
	(1) (ST)	ES AS				11 31 7 791 579 11 31 7 791 580		<b>50 007 682</b> (1) <b>50 007 683</b> (1)
	[8]	H 12 x 34,5 x 34,5				11 33 2 247 722 11 33 2 249 817		<b>50 006 414</b>
	[4]					11 12 2 247 056 11 33 2 248 878		<b>50 006 132</b>

					Reference	Item No.		
<b>61</b>		<b>84</b>						
<b>N47 D20 A</b>	09.2006 → 12.2013	D (A)	4	1995 cm <sup>3</sup>	4V	66-145 kW (90-197 PS)	17	90,00 mm
<b>N47 D20 B</b>	03.2007 → 12.2013	D (A)	4	1995 cm <sup>3</sup>	4V	150 kW (204 PS)	16	90,00 mm
<b>N47 D20 C</b>	04.2005 →	D (A)	4	1995 cm <sup>3</sup>	4V	66-150 kW (90-204 PS)	16	90,00 mm
<b>N47 D20 D</b>	03.2007 →	D (A)	4	1995 cm <sup>3</sup>	4V	150-160 kW (204-218 PS)	16,5	90,00 mm
41 264 6.., 41 265 6.., 41 493 6.., 41 494 6..								
	IN [2] EX [2]	27,2 x 5 x 94,0 24,6 x 5 x 94,0	S - - RA/S- Cr -	- 45° - - - 45° - -	22 - III 22 - III	11 12 7 797 711 11 34 7 797 712 11 34 7 812 615 11 34 8 511 622	<b>111216</b> <b>111215</b>	
	[50]	∅ 5 mm						<b>MK-5H</b>
	IN/EX [4] IN/EX [4] (1) 1. oversize	10,05 x 5 x 36,0 10,15 x 5 x 36,0	B1 B1					<b>81-11119</b> <b>81-11120</b> (1)
		AS ES				11 31 7 797 513 11 31 8 509 119 11 31 8 575 436 11 31 7 797 512 11 31 8 509 118 11 31 8 575 435	<b>50 007 785</b> <b>50 007 786</b>	
	[8]	H 12 x 34,5 x 34,5				11 33 2 247 722 11 33 2 249 817		<b>50 006 414</b>
	[4]					11 33 7 812 893		<b>50 006 133</b>
<b>62</b>		<b>84</b>						
<b>B37 C15 Euro 6</b>		D (A)	3	1496 cm <sup>3</sup>	4V	70-85 kW (95-116 PS)	16,5:1	90,00 mm
<b>B57 D30 B</b>	11.2015 →	D (A)	6	2993 cm <sup>3</sup>	4V	155-250 kW (211-340 PS)		90,00 mm
<b>N47 D20T0</b>		D (LA)	4	1995 cm <sup>3</sup>	4V	150 kW (204 PS)	16:1	90,00 mm
<b>N47 D20UL</b>	09.2008 → 05.2011	D (LA)	4	1995 cm <sup>3</sup>	4V	105 kW (143 PS)	16:1	90,00 mm
<b>N47S D20A</b>		D (LA)	4	1995 cm <sup>3</sup>	4V	150 kW (204 PS)	16:1	90,00 mm
<b>N57 D30 A</b>	06.2005 →	D (A)	6	2993 cm <sup>3</sup>	4V	150-210 kW (204-286 PS)	16,5	90,00 mm
<b>N57 D30 OL</b>		D (LA)	6	2993 cm <sup>3</sup>	4V	180-190 kW (245-258 PS)	16,5:1	90,00 mm
41 268 6.., 41 269 6..								
	IN [2] EX [2]	27,2 x 5 x 94,0 24,6 x 5 x 94,0	S - - RA/S- Cr -	- 45° - - - 45° - -	22 - III 22 - III	11 12 7 797 711 11 34 7 797 712 11 34 7 812 615 11 34 8 511 622	<b>111216</b> <b>111215</b>	
	[50]	∅ 5 mm						<b>MK-5H</b>
	IN/EX [4] IN/EX [4] (1) 1. oversize	10,05 x 5 x 36,0 10,15 x 5 x 36,0	B1 B1					<b>81-11119</b> <b>81-11120</b> (1)
	[8]	H 12 x 34,5 x 34,5				11 33 2 247 722 11 33 2 249 817		<b>50 006 414</b>
	[4]					11 33 7 812 893		<b>50 006 133</b>



					Reference	Item No.			
<b>63</b>		<b>84</b>							
<b>B37 C15 A Euro 6</b>	03.2014 →	D (A)	3	1496 cm <sup>3</sup>	4V	70-85 kW (95-116 PS)	16,5	90,00 mm	
<b>B37 D15 A Euro 6</b>	03.2015 →	D (A)	3	1496 cm <sup>3</sup>	4V	70-85 kW (95-116 PS)	16,5	90,00 mm	
<b>B47 C20 A Euro 6</b>	11.2013 →	D (A)	4	1995 cm <sup>3</sup>	4V	100-140 kW (136-190 PS)	16,5	90,00 mm	
<b>B47 D20 A Euro 6</b>	06.2010 →	D (A)	4	1995 cm <sup>3</sup>	4V	85-155 kW (116-211 PS)	16,5	90,00 mm	
<b>B57 D30 A</b>	07.2015 →	D (A)	6	2993 cm <sup>3</sup>	4V	155-235 kW (211-320 PS)		90,00 mm	
<b>N57 D30 B</b>	07.2009 →	D (A)	6	2993 cm <sup>3</sup>	4V	220-230 kW (299-313 PS)	16,5	90,00 mm	
<b>N57 D30 C</b>	01.2010 →	D (A)	6	2993 cm <sup>3</sup>	4V	280 kW (381 PS)	16,5	90,00 mm	
41 268 6..., 41 269 6..., 41 853 6..									
	IN [2] EX [2]	27,2 x 5 x 94,0 24,6 x 5 x 94,0	S - - RA/S- Cr -	- 45° - - - 45° - -	- 22 - III - 22 - III	11 12 7 797 711 11 34 7 797 712 11 34 7 812 615 11 34 8 511 622		<b>111216</b> <b>111215</b>	
	[50]	∅ 5 mm						<b>MK-5H</b>	
	IN/EX [4] IN/EX [4]	10,05 x 5 x 36,0 10,15 x 5 x 36,0	B1 B1					<b>81-11119</b> <b>81-11120</b> (1)	
	(1)	1. oversize							
	[8]	H 12 x 34,5 x 34,5				11 33 2 247 722 11 33 2 249 817		<b>50 006 414</b>	
	[4]					11 33 7 797 710 11 33 8 576 634		<b>50 007 810</b>	
<b>64</b>		<b>84</b>							
<b>B47 C20 B</b>	11.2014 →	D (A)	4	1995 cm <sup>3</sup>	4V	100-170 kW (136-231 PS)	16,5	90,00 mm	
<b>B47 D20 B</b>	03.2012 →	D (A)	4	1995 cm <sup>3</sup>	4V	85-170 kW (116-231 PS)	16,5	90,00 mm	
	[4]					11 33 7 797 710 11 33 8 576 634		<b>50 007 810</b>	
<b>65</b>		<b>84</b>							
<b>B57 D30 C</b>	07.2016 →	D (A)	6	2993 cm <sup>3</sup>	4V	294 kW (400 PS)		90,00 mm	
	IN [2] EX [2]	27,2 x 5 x 94,0 24,6 x 5 x 94,0	S - - RA/S- Cr -	- 45° - - - 45° - -	- 22 - III - 22 - III	11 12 7 797 711 11 34 7 797 712 11 34 7 812 615 11 34 8 511 622		<b>111216</b> <b>111215</b>	
	[50]	∅ 5 mm						<b>MK-5H</b>	
	IN/EX [4] IN/EX [4]	10,05 x 5 x 36,0 10,15 x 5 x 36,0	B1 B1					<b>81-11119</b> <b>81-11120</b> (1)	
	(1)	1. oversize							
	[8]	H 12 x 34,5 x 34,5				11 33 2 247 722 11 33 2 249 817		<b>50 006 414</b>	
	[4] [4]					11 33 7 812 893 11 37 7 539 966		<b>50 006 133</b> <b>50 007 850</b> (2)	
	(2)	Zwischenhebel							
<b>66</b>		<b>84</b>							
<b>M57 306 D5</b>		D (LA)	6	2993 cm <sup>3</sup>	4V	210 kW (286 PS)	16,5:1	90,00 mm	
	[8]	H 12 x 34,5 x 34,5				11 33 2 247 722 11 33 2 249 817		<b>50 006 414</b>	
Fortsetzung nächste Seite / continued on next page / suite page suivante / continuación página próxima / Продолжение на следующей странице									

					Reference	Item No.
[4]					11 33 7 812 893	50 006 133
<b>67</b>	<b>84</b>					
<b>M57 D30 TU TOP</b>	D (LA)	6	2993 cm <sup>3</sup>	4V	210-220 kW (286-298 PS)	16,5:1 90,00 mm
<b>N57 306 D2</b>	D	6	2993 cm <sup>3</sup>	4V	160 kW (218 PS)	90,00 mm
41 268 6.., 41 269 6..						
IN/EX [2]	25,9 x 6 x 99,9	RA/S- Cr -	- 45° - VS -	22 - III	11 34 2 247 077	111113
[50]	∅ 6 mm				11 34 0 150 844 11 34 1 461 405	MK-6H
IN/EX [6]	11,54 x 6 x 39,0	B1				81-11116
[8]	H 12 x 34,5 x 34,5				11 33 2 247 722 11 33 2 249 817	50 006 414
[4]					11 12 2 247 056 11 33 2 248 878	50 006 132
[4]					11 33 7 812 893	50 006 133
<b>68</b>	<b>84</b>					
<b>N57N 306 D2</b>	D	6	2993 cm <sup>3</sup>	4V	170 kW (231 PS)	90,00 mm
<b>N57N 306 D3</b>	D	6	2993 cm <sup>3</sup>	4V	145-170 kW (197-231 PS)	90,00 mm
<b>N57N 306 D5</b>	D	6	2993 cm <sup>3</sup>	4V	210 kW (286 PS)	90,00 mm
41 268 6.., 41 269 6..						
IN/EX [2]	25,9 x 6 x 99,9	RA/S- Cr -	- 45° - VS -	22 - III	11 34 2 247 077	111113
IN [2]	27,4 x 6 x 100,0	S - -	- 45° - -	22 - III	11 34 7 799 612	111221
[50]	∅ 6 mm				11 34 0 150 844 11 34 1 461 405	MK-6H
IN/EX [6]	11,54 x 6 x 39,0	B1				81-11116
[8]	H 12 x 34,5 x 34,5				11 33 2 247 722 11 33 2 249 817	50 006 414
[4]					11 12 2 247 056 11 33 2 248 878	50 006 132
<b>69</b>	<b>85</b>					
<b>M43 B19 TU OL</b>	B	4	1895 cm <sup>3</sup>	2V	87 kW (118 PS)	9,7:1 83,50 mm
<b>M43 B19 TU UL</b>	B	4	1895 cm <sup>3</sup>	2V	77 kW (105 PS)	9,7:1 83,50 mm
<b>M73 B54 (54121)</b>	09.1994 → 12.1999	B (NA)	12	5379 cm <sup>3</sup>	2V 240 kW (326 PS)	10 79,00 mm
<b>M73 B54 (54122)</b>	09.1998 → 07.2001	B (NA)	12	5379 cm <sup>3</sup>	2V 240-243 kW (326-330 PS)	10 79,00 mm
94 895 6..						
IN [2]	42,0 x 7 x 104,0	S - -	- 45° - -	22 - III	11 34 1 433 892 11 34 1 739 114 11 34 1 739 658	11673
EX [2]	36,0 x 7 x 103,0	A/S - Cr -	- 45° - VS -	22 - III	11 34 1 433 893 11 34 1 739 665	11672
[50]	∅ 7 mm				11 34 1 307 136	MK-7H
IN/EX [6]	12,54 x 7 x 43,5	B1			11 12 1 715 373	81-11101
IN/EX [6]	12,55 x 7 x 43,5	B1			11 12 1 715 373	81-11110
IN/EX [6]	12,64 x 7 x 43,5	B1				81-11102
IN/EX [6]	12,73 x 7 x 43,5	B1				81-11111
Fortsetzung nächste Seite / continued on next page / suite page suivante / continuación página próxima / Продолжение на следующей странице						

					Reference	Item No.
[8]	H 16 x 48,5				11 33 1 247 054 11 33 1 433 672 11 33 1 712 010 11 33 1 714 604 11 33 1 715 458 11 33 1 721 698	<b>50 006 476</b>

**70** **85**
**M44 B19 (194S1)** 09.1995 → 09.1999 B (NA) 4 1895 cm<sup>3</sup> 4V 103 kW (140 PS) 10 83,50 mm

IN [2]	33,0 x 6 x 106,1	S - -	- 45° - -	22 - III	11 34 1 438 284 11 34 1 438 385 11 34 1 438 451 11 34 1 738 218 11 34 1 739 820 11 34 1 739 822	<b>11960</b>
EX [2]	30,5 x 6 x 105,7	A/S - Cr -	- 45° - VS -	22 - III	11 34 1 738 219 11 34 1 739 821 11 34 1 739 823	<b>11964</b>
[50]	∅ 6 mm				11 34 0 150 844 11 34 1 461 405	<b>MK-6H</b>
IN/EX [6] IN/EX [6]	12,53 x 6 x 43,5 12,73 x 6 x 43,5	B1 B1			11 12 1 735 534	<b>81-11112</b> <b>81-11113</b>
[8]	H 16 x 48,5				11 33 1 247 054 11 33 1 433 672 11 33 1 712 010 11 33 1 714 604 11 33 1 715 458 11 33 1 721 698	<b>50 006 476</b>

**71** **85**
**N52 B30 A** 09.2004 → B (NA) 6 2996 cm<sup>3</sup> 4V 155-200 kW (211-272 PS) 10,7 88,00 mm  
**N52 B30 AE** B (NA) 6 2996 cm<sup>3</sup> 4V 179 kW (243 PS) 10,7 88,00 mm  
**N52 B30 AF** 09.2005 → 06.2015 B (NA) 6 2996 cm<sup>3</sup> 4V 179-200 kW (243-272 PS) 10,7 88,00 mm  
**N52 B30 B Euro 5** 09.2004 → 10.2013 B (NA) 6 2996 cm<sup>3</sup> 4V 160-200 kW (218-272 PS) 12 88,00 mm  
**N52 B30 BF** 09.2004 → 06.2015 B (NA) 6 2996 cm<sup>3</sup> 4V 160-200 kW (218-272 PS) 10,7 88,00 mm

IN [2]	34,2 x 5 x 104,5	S - -	- 45° - -	22 - III	11 34 7 539 915 11 34 7 553 771	<b>111219</b>
EX [2]	29,0 x 6 x 110,6	RA/S- -	- 45° - -	22 - III	11 34 7 553 772	<b>111220</b>
[50] [50]	∅ 5 mm ∅ 6 mm				11 34 0 150 844 11 34 1 461 405	<b>MK-5H</b> <b>MK-6H</b>
IN [6] IN [1] EX [6] EX [6] (1) 1. oversize	10,15 x 5 x 42,0 10,04 x 5 x 42,0 10,04 x 6 x 48,0 10,15 x 6 x 48,0	B1 B1 B1 B1				<b>81-11126</b> (1) <b>81-11125</b> <b>81-11127</b> <b>81-11128</b> (1)
[8]	H 12 x 34,5				11 33 7 546 466 11 33 7 548 690	<b>50 006 492</b>
[4]					11 33 7 559 797	<b>50 006 129</b>

**72** **85**
**N45 B20 A** 09.2005 → 08.2006 B (NA) 4 1997 cm<sup>3</sup> 4V 127 kW (173 PS) I 88,00 mm

[8]	H 12 x 34,5				11 33 1 707 712 11 33 7 512 116	<b>50 006 493</b>
-----	-------------	--	--	--	------------------------------------	-------------------

					Reference	Item No.	
<b>73</b>	<b>85</b>						
<b>N53 B30 A</b>	09.2006 → 12.2013	B (NA)	6	2996 cm <sup>3</sup> 4V	150-200 kW (204-272 PS) 12	88,00 mm	
	IN [2] EX [2]	32,0 x 5 x 106,7 29,0 x 6 x 114,6	S - - RA/S- Cr -	- 45° - Y - - 45° - -	22 - III 22 - III	11 34 7 552 952 11 34 7 552 953	<b>111800</b> <b>111801</b>
	[50] [50]	∅ 5 mm ∅ 6 mm				11 34 0 150 844 11 34 1 461 405	<b>MK-5H</b> <b>MK-6H</b>
	IN/EX [6] IN/EX [6] IN [6] IN [1] EX [6] EX [6] (1) 1. oversize	12,53 x 6 x 43,5 12,73 x 6 x 43,5 10,15 x 5 x 42,0 10,04 x 5 x 42,0 10,04 x 6 x 48,0 10,15 x 6 x 48,0	B1 B1 B1 B1 B1 B1			11 12 1 735 534	<b>81-11112</b> <b>81-11113</b> <b>81-11126</b> (1) <b>81-11125</b> <b>81-11127</b> <b>81-11128</b> (1)
	[8]	H 12 x 34,5				11 33 7 546 466 11 33 7 548 690	<b>50 006 492</b>
	[4]					11 33 7 559 797	<b>50 006 129</b>
<b>74</b>	<b>85</b>						
<b>N53 B30</b>		B	6	2996 cm <sup>3</sup> 4V	160-200 kW (218-272 PS) 12,0:1	88,00 mm	
	IN [2] EX [2]	32,0 x 5 x 106,7 29,0 x 6 x 114,6	S - - RA/S- Cr -	- 45° - Y - - 45° - -	22 - III 22 - III	11 34 7 552 952 11 34 7 552 953	<b>111800</b> <b>111801</b>
	[50] [50]	∅ 5 mm ∅ 6 mm				11 34 0 150 844 11 34 1 461 405	<b>MK-5H</b> <b>MK-6H</b>
	IN/EX [6] IN/EX [6] IN [6] IN [1] EX [6] EX [6] (1) 1. oversize	12,53 x 6 x 43,5 12,73 x 6 x 43,5 10,15 x 5 x 42,0 10,04 x 5 x 42,0 10,04 x 6 x 48,0 10,15 x 6 x 48,0	B1 B1 B1 B1 B1 B1			11 12 1 735 534	<b>81-11112</b> <b>81-11113</b> <b>81-11126</b> (1) <b>81-11125</b> <b>81-11127</b> <b>81-11128</b> (1)
<b>75</b>	<b>86</b>						
<b>M30 B25</b>	10.1973 → 06.1986	B (NA)	6	2494 cm <sup>3</sup> 2V	107-125 kW (145-170 PS) 9-9,6	71,60 mm	
<b>M30 B25 L</b>		B	6	2494 cm <sup>3</sup> 2V	110 kW (150 PS) 9,6:1	71,60 mm	
<b>M30 B28</b>	09.1967 → 08.1987	B (NA)	6	2788 cm <sup>3</sup> 2V	121-141 kW (165-192 PS) 9-9,3	80,00 mm	
<b>M30 B28 L</b>		B	6	2788 cm <sup>3</sup> 2V	126-135 kW (171-184 PS) 8,2-9,3	80,00 mm	
	IN [2] EX [2]	46,0 x 8 x 106,7 38,0 x 8 x 107,2	S - Cr - A/S - Cr -	- 45° - - - 45° - VS -	22 - III 22 - III	11 34 1 257 587 11 34 1 273 592 11 34 1 250 129	<b>1142</b> <b>1125</b>
	[50]	∅ 8 mm				11 34 1 710 975	<b>MK-8H</b>
	IN/EX [4] IN/EX [4] IN/EX [4]	14,00 x 8 x 50,0 14,10 x 8 x 50,0 14,20 x 8 x 50,0	B1 B1 B1			11 12 1 263 642 11 12 1 266 760 11 12 1 266 761	<b>81-1162</b> <b>81-1163</b> <b>81-1164</b>
<b>76</b>	<b>86</b>						
<b>S70 B56 (56121)</b>	11.1992 → 12.1996	B (NA)	12	5576 cm <sup>3</sup> 2V	277-280 kW (377-381 PS) 9,8	80,00 mm	
Fortsetzung nächste Seite / continued on next page / suite page suivante / continuación página próxima / Продолжение на следующей странице							

**B**

					Reference	Item No.
IN [2]	42,0 x 7 x 104,0	S - -	- 45° - -	22 - III	11 34 1 433 892 11 34 1 739 114 11 34 1 739 658	<b>11673</b>
EX [2]	36,0 x 7 x 103,0	A/S - Cr -	- 45° - VS -	22 - III	11 34 1 433 893 11 34 1 739 665	<b>11672</b>
[50]	Ø 7 mm				11 34 1 307 136	<b>MK-7H</b>
IN/EX [6]	12,54 x 7 x 43,5	B1			11 12 1 715 373	<b>81-11101</b>
IN/EX [6]	12,55 x 7 x 43,5	B1			11 12 1 715 373	<b>81-11110</b>
IN/EX [6]	12,64 x 7 x 43,5	B1				<b>81-11102</b>
IN/EX [6]	12,73 x 7 x 43,5	B1				<b>81-11111</b>

**77** **89**

<b>121</b>		B	4	1990 cm <sup>3</sup>	2V	74 kW	(100 PS)	8,5:1	80,00 mm
<b>M10 B18</b>	09.1965 → 07.1975	B (NA)	4	1766 cm <sup>3</sup>	2V	66-77 kW	(90-105 PS)	8,2-9,5	71,00 mm
<b>M10 B18 (184EA)</b>	09.1979 → 12.1983	B (NA)	4	1766 cm <sup>3</sup>	2V	66-77 kW	(90-105 PS)	8,2-9,5	71,00 mm
<b>M10 B18 (184EB)</b>	06.1979 → 06.1990	B (NA)	4	1766 cm <sup>3</sup>	2V	66-77 kW	(90-105 PS)	8,2-9,5	71,00 mm
<b>M10 B18 (184KA)</b>	12.1984 → 08.1988	B (NA)	4	1766 cm <sup>3</sup>	2V	66-77 kW	(90-105 PS)	8,2-9,5	71,00 mm
<b>M10 B18 (184VA)</b>	08.1975 → 08.1982	B (NA)	4	1766 cm <sup>3</sup>	2V	66-77 kW	(90-105 PS)	8,2-9,5	71,00 mm
<b>M10 B18 (184VB)</b>	07.1974 → 05.1981	B (NA)	4	1766 cm <sup>3</sup>	2V	66-77 kW	(90-105 PS)	8,2-9,5	71,00 mm
<b>M10 B18 (184VC)</b>	09.1980 → 09.1984	B (NA)	4	1766 cm <sup>3</sup>	2V	66-77 kW	(90-105 PS)	8,2-9,5	71,00 mm
<b>M10 B18 (184VD)</b>	06.1981 → 06.1988	B (NA)	4	1766 cm <sup>3</sup>	2V	66-77 kW	(90-105 PS)	8,2-9,5	71,00 mm
<b>M10 B18 K</b>		B	4	1767 cm <sup>3</sup>	2V	75-77 kW	(102-105 PS)	8,8-10	71,00 mm
<b>M10 B20</b>	09.1965 → 08.1982	B (NA)	4	1990 cm <sup>3</sup>	2V	74-101 kW	(101-137 PS)	8,1-9,5	80,00 mm

IN [2]	46,0 x 8 x 103,8	S - Cr -	- 45° - -	22 - III	11 34 1 254 625	<b>1132</b>
EX [2]	38,0 x 8 x 104,3	A/S - Cr -	- 45° - VS -	22 - III	11 34 1 251 063	<b>1123</b>
[50]	Ø 8 mm				11 34 1 710 975	<b>MK-8H</b>
IN/EX [4]	14,00 x 8 x 50,0	B1			11 12 1 263 642	<b>81-1162</b>
IN/EX [4]	14,10 x 8 x 50,0	B1			11 12 1 266 760	<b>81-1163</b>
IN/EX [4]	14,20 x 8 x 50,0	B1			11 12 1 266 761	<b>81-1164</b>

**78** **89**

<b>M30 B30</b>	09.1970 → 08.1979	B (NA)	6	2986 cm <sup>3</sup>	2V	131-147 kW	(176-200 PS)	9-9,2	80,00 mm
<b>M30 B30 (306EA)</b>	07.1971 → 01.1989	B (NA)	6	2986 cm <sup>3</sup>	2V	131-147 kW	(178-200 PS)	9-9,2	80,00 mm
<b>M30 B30 (306KA)</b>	07.1971 → 03.1994	B (NA)	6	2986 cm <sup>3</sup>	2V	131-147 kW	(178-200 PS)	9-9,2	80,00 mm
<b>M30 B30 V</b>	05.1971 → 08.1979	B	6	2986 cm <sup>3</sup>	2V	132-136 kW	(180-185 PS)	9:1	80,00 mm
<b>M30 B32</b>	10.1975 → 08.1986	B (NA)	6	3210 cm <sup>3</sup>	2V	130-152 kW	(177-207 PS)	9-10	86,00 mm
<b>M30 B32 (315/1A)</b>	01.1974 → 1985	B (NA)	6	3153 cm <sup>3</sup>	2V	152 kW	(206 PS)	9,5	86,00 mm
<b>M30 B32 LA</b>		B (LA)	6	3210 cm <sup>3</sup>	2V	185 kW	(252 PS)	7/7,5:1	86,00 mm
<b>M30 B32 LU</b>	01.1977 → 1983	B	6	3210 cm <sup>3</sup>	2V	130-132 kW	(176-179 PS)	8/8,4:1	86,00 mm
<b>M30 B32 M</b>		B	6	3210 cm <sup>3</sup>	2V	145 kW	(197 PS)	10:1	86,00 mm

IN [2]	46,0 x 8 x 106,7	S - Cr -	- 45° - -	22 - III	11 34 1 257 587 11 34 1 273 592	<b>1142</b>
EX [2]	38,0 x 8 x 107,2	A/S - Cr -	- 45° - VS -	22 - III	11 34 1 250 129	<b>1125</b>
[50]	Ø 8 mm				11 34 1 710 975	<b>MK-8H</b>
IN/EX [4]	14,00 x 8 x 50,0	B1			11 12 1 263 642	<b>81-1162</b>
IN/EX [4]	14,10 x 8 x 50,0	B1			11 12 1 266 760	<b>81-1163</b>
IN/EX [4]	14,20 x 8 x 50,0	B1			11 12 1 266 761	<b>81-1164</b>

					11 31 1 287 606	<b>50 006 234</b> (1)
(1) Schalenhartguss/chilled cast iron/pièce moulée trempée en surface/fundición en coquilla/Отливка с отбеленным поверхностным слоем						

**79** **89**

<b>M60 B40 (408S1)</b>	05.1992 → 07.1996	B (NA)	8	3982 cm <sup>3</sup>	4V	210 kW	(286 PS)	10	80,00 mm
------------------------	-------------------	--------	---	----------------------	----	--------	----------	----	----------

Fortsetzung nächste Seite / continued on next page / suite page suivante / continuación página próxima / Продолжение на следующей странице



					Reference	Item No.	
	IN [2] EX [2]	35,0 x 6 x 104,1 30,5 x 6 x 103,7	S - - RA/S- Cr -	- 45° - - - 45° - VS -	22 - III 22 - III	11 34 1 731 640 11 34 1 736 549 11 34 1 433 699 11 34 1 435 482	<b>11539</b> <b>111031</b>
	[50]	∅ 6 mm				11 34 0 150 844 11 34 1 461 405	<b>MK-6H</b>
	IN/EX [6] IN/EX [6]	12,53 x 6 x 43,5 12,73 x 6 x 43,5	B1 B1			11 12 1 735 534	<b>81-11112</b> <b>81-11113</b>

<b>80</b>		<b>89</b>							
<b>N63 B44 A</b>	10.2007 → 06.2018	B (A)	8	4395 cm <sup>3</sup>	4V	298-330 kW	(405-449 PS)	10	88,30 mm
<b>N63 B44 B</b>	09.2008 → 07.2019	B (A)	8	4395 cm <sup>3</sup>	4V	298-339 kW	(405-461 PS)	10	88,30 mm
40 631 6..									

	IN [2] EX [2]	33,2 x 6 x 102,8 29,0 x 6 x 106,0	S - Cr - RA/S- Cr - Na	- 45° - - - 45° - VS -	22 - III 22 - III	11 34 7 570 163 11 34 7 570 164	<b>111229</b> <b>111230</b>
	[50]	∅ 6 mm				11 34 0 150 844 11 34 1 461 405	<b>MK-6H</b>

<b>81</b>		<b>89</b>							
<b>S63 B44 A</b>	07.2008 → 07.2014	B (A)	8	4395 cm <sup>3</sup>	4V	408-414 kW	(555-563 PS)	9,3	88,30 mm

	IN [2] EX [2]	35,0 x 6 x 100,0 29,0 x 6 x 100,1	S - Cr - RA/S- Cr -	- 45° - - - 45° - VS -	22 - III 22 - III	11 34 1 435 461 11 34 7 503 737 11 34 7 541 555 11 34 1 707 519 11 34 4 457 287 11 34 7 503 738 11 34 7 529 839	<b>111208</b> <b>111209</b>
	[50]	∅ 6 mm				11 34 0 150 844 11 34 1 461 405	<b>MK-6H</b>
	IN/EX [6] IN/EX [4]	10,02 x 6.01 x 39,0 10,15 x 6.01 x 39,0	B1 B1				<b>81-11117</b> <b>81-11118</b> (1)
	(1)	1. oversize					
	[8]	H 12 x 34,5				11 33 1 707 712 11 33 7 512 116	<b>50 006 493</b>

<b>82</b>		<b>89</b>							
<b>N63 B44 C</b>	09.2015 → 06.2019	B (A)	8	4395 cm <sup>3</sup>	4V	330-340 kW	(449-462 PS)	10	88,30 mm

	IN [2] EX [2]	33,2 x 6 x 102,8 29,0 x 6 x 106,0	S - Cr - RA/S- Cr - Na	- 45° - - - 45° - VS -	22 - III 22 - III	11 34 7 570 163 11 34 7 570 164	<b>111229</b> <b>111230</b>
	[50]	∅ 6 mm				11 34 0 150 844 11 34 1 461 405	<b>MK-6H</b>
	[4]					11 37 7 539 966	<b>50 007 850</b> (1)
	(1)	Zwischenhebel					

<b>83</b>		<b>89</b>							
<b>N63 B44 D</b>	08.2018 →	B (A)	8	4395 cm <sup>3</sup>	4V	340-390 kW	(462-530 PS)	10	88,30 mm

	[4]					11 37 7 539 966	<b>50 007 850</b> (1)
	(1)	Zwischenhebel					

						Reference	Item No.	
<b>84</b>		<b>89</b>						
<b>118,3 KH</b>		B	4	1766 cm <sup>3</sup>	2V	66 kW (90 PS) 8,6:1	71,00 mm	
<b>M10 B18 S</b>		B	4	1767 cm <sup>3</sup>	2V	66 kW (90 PS) 9,5:1	71,00 mm	
<b>M10 B18 V</b>		B	4	1767 cm <sup>3</sup>	2V	66 kW (90 PS) 9,5:1	71,00 mm	
	IN [2] EX [2]	42,0 x 8 x 103,8 35,0 x 8 x 104,3	S - - A/S - Cr -	- 45° - - - 45° - VS -	- - - -	22 - III 22 - III	11 34 1 251 879 11 34 1 251 498	<b>1195</b> <b>1198</b>
	[50]	∅ 8 mm					11 34 1 710 975	<b>MK-8H</b>
	IN/EX [4] IN/EX [4] IN/EX [4]	14,00 x 8 x 50,0 14,10 x 8 x 50,0 14,20 x 8 x 50,0	B1 B1 B1				11 12 1 263 642 11 12 1 266 760 11 12 1 266 761	<b>81-1162</b> <b>81-1163</b> <b>81-1164</b>
<b>85</b>		<b>90</b>						
<b>247/60</b>		B	2	898 cm <sup>3</sup>	2V	44 kW (60 PS) 9:1	70,60 mm	
<b>247/67</b>		B	2	898 cm <sup>3</sup>	2V	49 kW (67 PS) 9,5:1	70,60 mm	
	IN [2] EX [2]	42,0 x 8 x 98,6 40,0 x 8 x 98,6	S - Cr - RA/S- Cr -	- 45° - - - 45° - -	- - - -	22 - III 22 - III	11 34 1 250 234 11 34 1 257 837	<b>1135</b> <b>111203</b>
	[50]	∅ 8 mm					11 34 1 710 975	<b>MK-8H</b>
	IN/EX [4] IN/EX [4] IN/EX [4] IN/EX [4]	14,10 x 8 x 44,0 14,10 x 8 x 46,5 14,20 x 8 x 44,0 14,30 x 8 x 44,0	B1 CC B1 B1 B1				11 12 1 259 934 11 12 1 338 708 11 12 1 259 935	<b>81-1153</b> <b>81-11109</b> <b>81-1154</b> <b>81-1155</b> (1)
	(1) Kegelstückfixierung/cotter fixation/fijación de chavetas/fijación de chavetas/Крепление конического сухаря ∅ 6 mm							
<b>86</b>		<b>92</b>						
<b>M30 B35</b>	05.1982 → 06.1987	B (NA)	6	3430 cm <sup>3</sup>	2V	160 kW (218 PS) 10	86,00 mm	
<b>(Motronic,10)</b>								
<b>M30 B35</b>	07.1986 → 01.1989	B (NA)	6	3430 cm <sup>3</sup>	2V	162 kW (220 PS) 9,2	86,00 mm	
<b>(Motronic,9)</b>								
	IN [2] EX [2]	47,0 x 8 x 106,7 38,0 x 8 x 107,2	S - Cr - A/S - Cr -	- 45° - - - 45° - VS -	- - - -	22 - III 22 - III	11 34 1 705 560 11 34 1 250 129	<b>11102</b> <b>1125</b>
	[50]	∅ 8 mm					11 34 1 710 975	<b>MK-8H</b>
	IN/EX [4] IN/EX [4] IN/EX [4]	14,00 x 8 x 50,0 14,10 x 8 x 50,0 14,20 x 8 x 50,0	B1 B1 B1				11 12 1 263 642 11 12 1 266 760 11 12 1 266 761	<b>81-1162</b> <b>81-1163</b> <b>81-1164</b>
							11 31 1 287 606	<b>50 006 234</b> (1)
	(1) Schalenhartguss/chilled cast iron/pièce moulée trempée en surface/fundición en coquilla/Отливка с отбеленным поверхностным слоем							
<b>87</b>		<b>92</b>						
<b>M62 B44 (448S1)</b>	02.1996 → 12.2003	B (NA)	8	4398 cm <sup>3</sup>	4V	210 kW (286 PS) 10	82,70 mm	
<b>M62 B44 (448S2)</b>	03.1996 → 12.2003	B (NA)	8	4398 cm <sup>3</sup>	4V	210 kW (286 PS) 10	82,70 mm	
	IN [2] EX [2]	35,0 x 6 x 104,1 30,5 x 6 x 103,7	S - - RA/S- Cr -	- 45° - - - 45° - VS -	- - - -	22 - III 22 - III	11 34 1 731 640 11 34 1 736 549 11 34 1 433 699 11 34 1 435 482	<b>11539</b> <b>111031</b>
	[50]	∅ 6 mm					11 34 0 150 844 11 34 1 461 405	<b>MK-6H</b>
Fortsetzung nächste Seite / continued on next page / suite page suivante / continuación página próxima / Продолжение на следующей странице								

					Reference	Item No.
	IN/EX [6] 12,53 x 6 x 43,5	B1			11 12 1 735 534	81-11112
	IN/EX [6] 12,73 x 6 x 43,5	B1				81-11113

<b>88</b>							
<b>N62 B44 A</b> 07.2001 → 12.2010 B (NA) 8 4398 cm <sup>3</sup> 4V 235-245 kW (320-333 PS) 10 82,70 mm							
	IN [2] 35,0 x 6 x 100,0	S - Cr -	- 45° - -	22 - III	11 34 1 435 461 11 34 7 503 737 11 34 7 541 555	<b>111208</b>	
	EX [2] 29,0 x 6 x 100,1	RA/S- Cr -	- 45° - VS -	22 - III	11 34 1 707 519 11 34 4 457 287 11 34 7 503 738 11 34 7 529 839	<b>111209</b>	
	[50] Ø 6 mm				11 34 0 150 844 11 34 1 461 405	<b>MK-6H</b>	
	IN/EX [6] 10,02 x 6.01 x 39,0	B1				<b>81-11117</b>	
	IN/EX [4] 10,15 x 6.01 x 39,0	B1				<b>81-11118</b> <small>NEW</small> (1)	
	(1) 1. oversize						
	[8] H 12 x 34,5				11 33 1 707 712 11 33 7 512 116	<b>50 006 493</b>	

<b>89</b>							
<b>M30 B34 M.45</b> B 6 3430 cm <sup>3</sup> 2V 136 kW (185 PS) 8:1 86,00 mm							
<b>M30 B34 MA</b> B (LA) 6 3430 cm <sup>3</sup> 2V 185 kW (252 PS) 8:1 86,00 mm							
<b>M30 B34 ME</b> B 6 3430 cm <sup>3</sup> 2V 150-160 kW (204-218 PS) 10:1 86,00 mm							
	IN [2] 46,0 x 8 x 106,7	S - Cr -	- 45° - -	22 - III	11 34 1 257 587 11 34 1 273 592	<b>1142</b>	
	EX [2] 38,0 x 8 x 107,2	A/S - Cr -	- 45° - VS -	22 - III	11 34 1 250 129	<b>1125</b>	
	[50] Ø 8 mm				11 34 1 710 975	<b>MK-8H</b>	
	IN/EX [4] 14,00 x 8 x 50,0	B1			11 12 1 263 642	<b>81-1162</b>	
	IN/EX [4] 14,10 x 8 x 50,0	B1			11 12 1 266 760	<b>81-1163</b>	
	IN/EX [4] 14,20 x 8 x 50,0	B1			11 12 1 266 761	<b>81-1164</b>	

<b>90</b>							
<b>M62 B46 (468S1)</b> 10.2001 → 09.2003 B (NA) 8 4619 cm <sup>3</sup> 4V 255-261 kW (347-355 PS) 10,5 85,00 mm							
	IN [2] 35,0 x 6 x 104,1	S - -	- 45° - -	22 - III	11 34 1 731 640 11 34 1 736 549	<b>11539</b>	
	EX [2] 30,5 x 6 x 103,7	RA/S- Cr -	- 45° - VS -	22 - III	11 34 1 433 699 11 34 1 435 482	<b>111031</b>	
	[50] Ø 6 mm				11 34 0 150 844 11 34 1 461 405	<b>MK-6H</b>	
	IN/EX [6] 12,53 x 6 x 43,5	B1			11 12 1 735 534	<b>81-11112</b>	
	IN/EX [6] 12,73 x 6 x 43,5	B1				<b>81-11113</b>	

<b>91</b>							
<b>N62 B48</b> B 8 4799 cm <sup>3</sup> 4V 261-270 kW (355-367 PS) 10,5:1 88,30 mm							
<b>N62 B48 A</b> 04.2004 → 12.2010 B (NA) 8 4799 cm <sup>3</sup> 4V 261-270 kW (355-367 PS) 10,5 88,30 mm							
<b>N62 B48 B</b> 03.2005 → 12.2010 B (NA) 8 4799 cm <sup>3</sup> 4V 261-270 kW (355-367 PS) 10,5 88,30 mm							
	IN [2] 35,0 x 6 x 100,0	S - Cr -	- 45° - -	22 - III	11 34 1 435 461 11 34 7 503 737 11 34 7 541 555	<b>111208</b>	
	EX [2] 29,0 x 6 x 100,1	RA/S- Cr -	- 45° - VS -	22 - III	11 34 1 707 519 11 34 4 457 287 11 34 7 503 738 11 34 7 529 839	<b>111209</b>	

Fortsetzung nächste Seite / continued on next page / suite page suivante / continuación página próxima / Продолжение на следующей странице

					Reference	Item No.
[50]	Ø 6 mm				11 34 0 150 844 11 34 1 461 405	<b>MK-6H</b>
IN/EX [6] IN/EX [4]	10,02 x 6.01 x 39,0 10,15 x 6.01 x 39,0	B1 B1				<b>81-11117</b> <b>81-11118</b> (1)
(1) 1. oversize						
[8]	H 12 x 34,5				11 33 1 707 712 11 33 7 512 116	<b>50 006 493</b>

**92** **93,4**
**M30 B35 (L-Jetronic, 10.1982 → 04.1982** B (NA) 6 3453 cm<sup>3</sup> 2V 160 kW (218 PS) 10 84,00 mm

IN [2]	46,0 x 8 x 106,7	S - Cr -	- 45° - -	22 - III	11 34 1 257 587 11 34 1 273 592	<b>1142</b>
EX [2]	38,0 x 8 x 107,2	A/S - Cr -	- 45° - VS -	22 - III	11 34 1 250 129	<b>1125</b>
[50]	Ø 8 mm				11 34 1 710 975	<b>MK-8H</b>
IN/EX [4]	14,00 x 8 x 50,0	B1			11 12 1 263 642	<b>81-1162</b>
IN/EX [4]	14,10 x 8 x 50,0	B1			11 12 1 266 760	<b>81-1163</b>
IN/EX [4]	14,20 x 8 x 50,0	B1			11 12 1 266 761	<b>81-1164</b>

**93** **93,4**
**S14 B23 (234EA)** 01.1986 → 06.1991 B (NA) 4 2302 cm<sup>3</sup> 4V 143-162 kW (195-220 PS) 9,6-11 84,00 mm  
**S14 B23 (234S1)** 07.1986 → 06.1991 B (NA) 4 2302 cm<sup>3</sup> 4V 143-162 kW (195-220 PS) 9,6-11 84,00 mm  
**S14 B23 (234S2)** 01.1986 → 10.1993 B (NA) 4 2303 cm<sup>3</sup> 4V 143-162 kW (195-220 PS) 9,6-11 84,00 mm

IN [2]	37,0 x 7 x 121,4	RA/S- Cr -	- 45° - VS -	22 - III	11 34 1 309 343	<b>11211</b>
[50]	Ø 7 mm				11 34 1 307 136	<b>MK-7H</b>

**94** **94**
**S62 B50 (508S1)** 10.1998 → 12.2003 B (NA) 8 4941 cm<sup>3</sup> 4V 294 kW (400 PS) 11 89,00 mm

[8]	H 33 x 24 x 24				11 32 1 748 880 11 32 1 748 881 11 32 1 748 882 11 32 1 748 884	<b>50 006 409</b>
-----	----------------	--	--	--	--	-------------------

**95** **94**
**1.0L (44 kW)** B 2 980 cm<sup>3</sup> 2V 44-47 kW (60-65 PS) 8,5:1 70,60 mm

IN [2]	42,0 x 8 x 98,6	S - Cr -	- 45° - -	22 - III	11 34 1 250 234	<b>1135</b>
EX [2]	40,0 x 8 x 98,7	RA/S- Cr -	- 30° - -	22 - III	11 34 1 338 285	<b>111202</b>
[50]	Ø 8 mm				11 34 1 710 975	<b>MK-8H</b>
IN/EX [4]	14,10 x 8 x 44,0	B1 CC			11 12 1 259 934	<b>81-1153</b>
IN/EX [4]	14,10 x 8 x 46,5	B1			11 12 1 338 708	<b>81-11109</b>
IN/EX [4]	14,20 x 8 x 44,0	B1			11 12 1 259 935	<b>81-1154</b>
IN/EX [4]	14,30 x 8 x 44,0	B1				<b>81-1155</b> (1)
(1) Kegelstückfixierung/cotter fixation/fijación de chavetas/fijación de chavetas/Крепление конического сухаря Ø 6 mm						

**96** **94**
**1.0L (48 kW)** B 2 980 cm<sup>3</sup> 2V 48-52 kW (65-70 PS) 9,5:1 70,60 mm

IN [2]	44,0 x 8 x 98,6	S - Cr -	- 45° - -	22 - III	11 34 1 261 751	<b>1154</b>
EX [2]	40,0 x 8 x 98,6	RA/S- Cr -	- 45° - -	22 - III	11 34 1 257 837	<b>111203</b>

Fortsetzung nächste Seite / continued on next page / suite page suivante / continuación página próxima / Продолжение на следующей странице





Cyl.	Cyl. Diagram	Cyl.	mm	cm <sup>3</sup>	Comp. Ratio	ε	kW	PS	Pos
100 GBC.000	B	4	65 x 68	903	2	9,5:1	38	52	1
100 GBC.040	B	4	65 x 68	903	2	9,5:1	38	52	1
100 GF 000	B (NA)	4	65 x 68	903	2	7,8	26	35	1
100 GL.000	B (NA)	4	65 x 68	903	2	9	30-33	41-45	1
100 GL.048	B (NA)	4	65 x 68	903	2	7,8	29	40	1
100 GL.0N.0	B	4	65 x 68	903	2	9:1	33	45	1
100 GL.3C.0	B	4	65 x 68	903	2	9:1	33	45	1
100 GL.9C.0	B	4	65 x 68	903	2	9:1	33	45	1
100 GL.9N.0	B	4	65 x 68	903	2	9:1	33	45	1
100 GL3.000	B	4	65 x 68	903	2	9	33	45	1
100 GL6.000	B (NA)	4	65 x 63,6	843	2	8	25	34	1
110 F.000	B (NA)	2	67,4 x 70	499	2	7,1	13	18	6
1170 A1.000	B (NA)	4	65 x 67,7	899	2	8,8:1	29-30	40-41	3
1170 A1.046	B (NA)	4	65 x 67,7	899	2	8,8	29	39	4
120.000	B (NA)	2	67,4 x 70	499	2	7,1:1	13	18	6
126 A.000	B (NA)	2	73,5 x 70	594	2	7,5	17	23	24
126 A1.000	B (NA)	2	77 x 70	652	2	7,5:1	17	23	30
126 AB.0C.0	B (NA)	2	73,5 x 70	594	2	7,5:1	17	23	24
126 AB.5C.0	B (NA)	2	73,5 x 70	594	2	7,5:1	13	18	24
127 AB.0C.0	B	4	76 x 57,8	1049	2	9,3:1	37	50	27
127 AB.0N.0	B	4	76 x 57,8	1049	2	9,3:1	37	50	27
127 AJ.0C.0	B	4	76 x 57,8	1049	2	9,3:1	37	50	27
127A.046	B (NA)	4	76,1 x 57,8	1049	2	9,5	37	50	29
128 A3.000	B (NA)	4	86,4 x 55,5	1301	2	9,1:1	55	75	91
128 AS.000	B (NA)	4	86 x 55,5	1290	2	9,2	46-55	63-75	85
128 BB.0A0	B (NA)	4	80 x 55,5	1116	2	8,8:1	48	65	38
131 B1.000	B (NA)	4	84 x 71,5	1585	2	9	72	98	70
131 C1.000	B (NA)	4	78 x 71,5	1367	2	8,9:1	51-55	69-75	31
131 C4.000	B (NA)	4	84 x 90	1995	2	9	83-85	113-116	70
132 B2.000	B (NA)	4	84 x 90	1995	2	9:1	83	113	70
132 D.000	B (NA)	4	84 x 71,5	1585	2	9	66-72	90-98	70
132 D1.000	B (NA)	4	84 x 90	1995	2	9	83	113	70
132 DB.2A.O	B (NA)	4	84 x 90	1995	2	9:1	82	112	70
138 A1.000	B (NA)	4	86,4 x 55,5	1301	2	9	48	65	91
138 A2.000	B (NA)	4	86,4 x 63,9	1498	2	9	55-57	75-78	91
138 A3.000	B (NA)	4	86,4 x 55,5	1301	2	9	55	75	91
138 A4.000	B (NA)	4	86,4 x 63,9	1498	2	9,2	63	86	91
138 AE 0A.0	B (NA)	4	80 x 55,5	1116	2	9,2:1	44	60	38
138 AR.000	B (NA)	4	84 x 71,5	1585	2	9,3	66-77	90-105	70
138 AR1.000	B (NA)	4	84 x 90	1995	2	9,4:1	92	125	70
138 AR2.000	B (NA)	4	84 x 90	1995	2	9,4:1	96	130	70
138 B.000	B (NA)	4	80 x 55,5	1116	2	9,2	40-44	55-60	37
138 B1.000	B (NA)	4	80 x 55,5	1116	2	9,6	40	55	37
138 B2.000	B (NA)	4	86,4 x 55,5	1302	2	9,1	50-51	68-69	91
138 B3.000	B (NA)	4	86,4 x 63,9	1498	2	9,2	55-63	75-86	91
138 B3.048	B (NA)	4	86,4 x 63,9	1498	2	9	55-57	75-78	91
138 C1.000	B (NA)	4	80 x 55,5	1116	2	9,2	40-42	55-57	37
138 C2.048	B (NA)	4	86,4 x 63,9	1498	2	9	55	75	91
141 B.000	B (NA)	4	65 x 58	769	2	9,2	25	34	1
146 A.000	B (NA)	4	65 x 68	903	2	9	33	45	2
146 A1.000	B (NA)	4	65 x 68	903	2	9	33	45	3
146 A4.000	B (NA)	4	80 x 55,5	1116	2	9,2	43-44	58-60	37
146 A4.048	B (NA)	4	80 x 55,5	1116	2	9,2	43	58	37
146 B2.000	D (NA)	4	82,6 x 79,2	1698	2	20,5	42-44	57-60	60
146 C1.000	B (NA)	4	80,5 x 67,4	1372	2	9,2	51-57	69-78	41
146 D7.000	D (A)	4	82,6 x 79,2	1698	2	20	46	63	60
149 A1.000	D (NA)	4	82,6 x 90	1929	2	21	48	65	60
149 A2.000	B (NA)	4	84 x 71,5	1585	2	9,3	74	101	70
149 A4.000	B (NA)	4	84 x 71,5	1585	2	9,3	74	101	70
149 A5.000	B (NA)	4	86,4 x 63,9	1498	2	9,2	58	79	91
149 A7.000	B (NA)	4	86,4 x 55,5	1302	2	9,6	48	65	91
149 A7.003	B (NA)	4	86,4 x 55,5	1301	2	9,2:1	48-50	65-68	91
149 B1.000	D (NA)	4	82,6 x 90	1929	2	21	51-52	70-71	61
149 B3.000	D (NA)	4	82,6 x 79,2	1698	2	20,5	44	60	61
149 B4.000	D (NA)	4	82,6 x 79,2	1697	2	20	42-45	57-61	61
149 B4.046	D (NA)	4	82,6 x 79,2	1697	2	20	42-44	57-60	60
154 A1.000	B (NA)	4	84 x 90	1995	2	8	66-74	90-101	70
154 B.000	D (LA)	4	82,6 x 90	1929	2	20:1	68	92	60
154 E1.000	B (NA)	4	84 x 90	1995	4	10,3:1	93-101	126-137	72

		Cyl.		mm	cm <sup>3</sup>		Comp. Ratio $\epsilon$	kW	PS	Pos
156 A.000	B (NA)	4		76,1 x 57,8	1049	2	9,5	37-41	50-56	28
156 A2.000	B (NA)	4		70 x 64,9	999	2	9,5	31-37	42-50	14
156 A2.048	B (NA)	4		70 x 64,9	999	2	9,2	32	44	15
156 A2.100	B (NA)	4		70 x 64,9	999	2	9	32-33	44-45	15
156 A2.246	B (NA)	4		70 x 64,9	999	2	9,5	33-40	45-54	14
156 A3.000	B (NA)	4		70 x 64,9	999	2	9,8	37	50	14
156 A3.100	B (NA)	4		70 x 64,9	999	2	9,5	32-33	44-45	14
156 A4.000	B (NA)	4		65 x 58	770	2	9,4	25	34	1
156 A4.048	B (NA)	4		65 x 58	770	2	9,4	25	34	1
156 C.046	B (NA)	4		70 x 72	1108	2	9,6	37-43	50-58	14
159 A2.000	B (NA)	4		80,5 x 67,4	1372	2	9,2	51-57	69-78	41
159 A3.000	B (NA)	4		86,4 x 67,4	1581	2	9,2	62-69	84-94	91
159 A4.000	B (NA)	4		84 x 79,2	1756	2	9,5	74-81	101-110	70
159 A6.046	B (NA)	4		84 x 90	1995	2	9,5	76-85	103-116	70
160 A1.000	B (NA)	4		80,5 x 67,4	1372	2	9,2	52-56	71-76	40
160 A2.000	B (NA)	4		86,4 x 67,4	1581	2	9,2	58-62	79-84	91
160 A3.000	B (NA)	4		70 x 72	1108	2	9,6	36-43	56-58	14
160 A5.000	B (NA)	4		84 x 79,2	1756	4	9,9	100	136	72
160 A6.000	D (A)	4		82,6 x 90	1929	2	19,2	66-68	90-92	62
160 A6.046	D (A)	4		82,6 x 90	1929	2	19,2	66-69	90-94	62
160 A7.000	D (NA)	4		82,6 x 90	1929	2	21	48	65	60
160 B6.046	D (A)	4		82,6 x 90	1929	2	19,2:1	59	82	62
169 A1.000	D (A)	4		69,6 x 82	1248	4	17,6	55	75	7
169 A3.000	B (NA)	4		72 x 84	1368	4	10,8:1	74-79	100-107	21
169 A4.000	B (NA)	4		70,8 x 78,9	1242	2	11,1	51	69	19
169 A5.000	D (A)	4		69,6 x 82	1248	4	16,8	55	75	10
170 A1.000	B	4		65 x 68	903	2	8,8	30	41	3
170 A1.046	B (NA)	4		65 x 68	903	2	8,8	30	41	4
175 A1.000	B (A)	4		84 x 90	1995	4	8	140	190	72
175 A3.000	B (A)	5		82 x 75,7	1998	4	8,5	162	220	46
176 A3.000	D (A)	4		82,6 x 79,2	1698	2	20,3	51-53	69-72	60
176 A5.000	D (A)	4		82,6 x 79,2	1698	2	19,1	52-59	71-80	63
176 A6.000	B (NA)	4		70 x 72	1108	2	9,6	40	54	14
176 A7.000	B (NA)	4		70,8 x 78,9	1242	2	9,6	43-44	58-60	16
176 A8.000	B (NA)	4		70,8 x 78,9	1242	2	9,8	54	73	16
176 A9.000	B (NA)	4		86,4 x 67,4	1581	2	9,5	65	88	92
176 B1.000	B (NA)	4		70,8 x 78,9	1242	2	10,2	44	60	16
176 B2.000	B (NA)	4		70 x 72	1108	2	9,6	40	54	14
176 B3.000	D (NA)	4		82,6 x 79,2	1698	2	20,5	42	57	60
176 B4.000	B (NA)	4		70,8 x 78,9	1242	2	9,8	44	60	17
176 B7.000	D (A)	4		82,6 x 79,2	1698	2	19,1	46-47	63-64	60
176 B9.000	B (NA)	4		70,8 x 78,9	1242	4	10,2	63	86	18
178 B3.000	B (NA)	4		86,4 x 67,4	1581	4	10,15	74-85	100-116	94
178 C7.098	B (NA)	4		86,4 x 67,4	1581	4	10,5:1	68-76	92-103	95
178 D2.011	B (NA)	4		86,4 x 67,4	1581	4	10,5	60-78	82-106	95
178 E2.000	B (NA)	4		70,8 x 78,9	1242	2	9,8	50-54	68-73	17
178 E7.000	B (NA)	4		80,5 x 78,4	1596	4	10,5	74-75	101-102	44
182 A1.000	B (NA)	5		82 x 75,7	1998	4	10	108-113	147-154	46
182 A2.000	B (NA)	4		82 x 82,7	1747	4	10,3	83	113	45
182 A3.000	B (NA)	4		82 x 64,8	1370	3	9,8	59	80	47
182 A4.000	B (NA)	4		86,4 x 67,4	1581	4	10,5	76-85	103-116	94
182 A4.027	B	4		86,4 x 67,4	1581	4	10,15:1	76	103	95
182 A5.000	B (NA)	4		82 x 64,9	1370	3	9,8	55	75	48
182 A6.000	B (NA)	4		86,4 x 67,4	1581	4	10,1	66	90	93
182 A7.000	D (A)	4		82 x 90,4	1910	2	20,7	74	100	50
182 A8.000	D (A)	4		82 x 90,4	1910	2	20,7	55	75	50
182 B2.000	B (NA)	4		70,8 x 78,9	1242	4	10,2:1	60-64	82-87	18
182 B3.000	B (NA)	5		82 x 75,65	1998	4	10	113	154	46
182 B4.000	D (A)	4		82 x 90,4	1910	2	18,45	77-79	105-107	52
182 B6.000	B (NA)	4		80,5 x 78,4	1596	4	10,5	68-100	92-136	42
182 B7.000	B (NA)	5		82 x 75,65	1998	4	10,7	113	154	45
182 B9.000 Euro 3	D (A)	4		82 x 90,4	1910	2	18,45	74-79	100-107	51
183 A1.000	B (NA)	4		82 x 82,7	1747	4	10,3	92-97	125-132	45
185 A2.000	D (A)	5		82 x 90,4	2387	2	20,7	91	125	50
185 A3.000 Euro 3	BG (NA)	4		86,4 x 67,4	1581	4	10,1	68-76	92-103	89
185 A6.000	D (A)	5		82 x 90,4	2387	2	18,45	96	130	52
185 A8.000 Euro 3	B (NA)	5		82 x 75,7	1998	4	10,5	110	150	49
185 B4.000	D (LA)	4		82 x 90,4	1910	2	18,45:1	77	105	52
186 A3.000	BG (NA)	4		86,4 x 67,4	1581	4	12,5	70	95	90

**F**

Cyl.	Cyl. Diagram	cm <sup>3</sup>	Comp. Ratio $\epsilon$	kW	PS	Pos		
							mm	
186 A4.000	BG (NA) 4	86,4 x 67,4	1581	4	10,5	68-76	92-103	89
186 A6.000	D (A) 4	82 x 90,4	1910	2	18,45	81	110	51
186 A8.000	D (A) 4	82 x 90,4	1910	2	18,45:1	85	115	52
186 A9.000	D (A) 4	82 x 90,4	1910	2	18:1	88	120	51
187 A1.000	B (NA) 4	70 x 72	1108	2	9,6	40-42	54-57	15
188 A2.000	D (A) 4	82 x 90,4	1910	2	18,4	59	80	51
188 A3.000	D (NA) 4	82 x 90,4	1910	2	22,5	44	60	52
188 A4.000	B (NA) 4	70,8 x 78,9	1242	2	9,5-9,8	38-44	52-60	17
188 A5.000	B (NA) 4	70,8 x 78,9	1242	4	10,6	57-60	78-82	18
188 A6.000	B (NA) 4	82 x 82,7	1747	4	10,3	96	130	45
188 A7.000	D (A) 4	82 x 90,4	1910	2	18,5	63	86	52
188 A8.000	D (A) 4	69,6 x 82	1248	4	18	51	70	8
188 A9.000	D (A) 4	69,6 x 82	1248	4	18	51-66	70-90	7
188 B2.000	D (A) 4	82 x 90,4	1910	2	18	74	101	51
192 A1.000	D (A) 4	82 x 90,4	1910	2	18,5	85	115	51
192 A2.000	B (NA) 5	83 x 90,4	2446	4	10,5	117-125	159-170	65
192 A3.000	D (A) 4	82 x 90,4	1910	2	18,5	59	80	51
192 A4.000	B (NA) 4	82 x 82,7	1747	4	10,3	90-98	122-133	45
192 A5.000	D (A) 4	82 x 90,4	1910	4	18,5	103	140	54
192 A8.000	D (A) 4	82 x 90,4	1910	2	18:1	88	120	51
192 A9.000	D (A) 4	82 x 90,4	1910	2	18,45	74	100	51
192 B1.000	D (A) 4	82 x 90,4	1910	4	18,5	100	136	55
192 B2.000	B (NA) 4	72 x 84	1368	4	11	66	90	21
194 A1.000	B (NA) 4	86 x 94,6	2198	4	10	108	147	88
198 A1.000	B (A) 4	72 x 84	1368	4	9,6-10	104-112	141-152	23
198 A2.000	D (A) 4	79,5 x 80,5	1598	4	16,1-16,9	88	120	35
198 A3.000	D (A) 4	79,5 x 80,5	1598	4	16,5	77	105	33
198 A4.000	B (A) 4	72 x 84	1368	4	9,6-10	88	120	23
198 A5.000	D (A) 4	83 x 90,4	1956	4	16,5	121	165	69
198 A6.000	D (A) 4	79,5 x 80,5	1598	4	16,5	66	90	34
199 A1.000	D (A) 4	69,6 x 82	1248	4	16,8	55	75	11
199 A2.000	D (A) 4	69,6 x 82	1248	4	18	55-68	75-93	7
199 A3.000	D (A) 4	69,6 x 82	1248	4	18	63-70	86-95	9
199 A4.000 Euro 4	B (NA) 4	70,8 x 78,9	1242	2	11	48-51	65-69	19
199 A5.000	D (A) 4	82 x 90,4	1910	2	18	96	131	51
199 A6.000	B (NA) 4	72 x 84	1368	4	11	70-71	95-97	21
199 A7.000	B (NA) 4	72 x 84	1368	2	11	55	75	22
199 A9.000 Euro 5	D (A) 4	69,6 x 82	1248	4	17,6	55-59	75-80	12
199 B1.000 Euro 5	D (A) 4	69,6 x 82	1248	4	16,8	64-70	87-95	12
199 B2.000 Euro 5	D (A) 4	69,6 x 82	1248	4	17,6	51	69	12
199 B4.000 Filter	D (A) 4	69,6 x 82	1248	4	16,8	62	84	12
199 B8.000	D (A) 4	69,6 x 82	1248	4		59	80	13
223 A5.000	B (NA) 4	70,8 x 78,9	1242	2	9,8	48	65	17
223 A6.000 Euro 3	D (NA) 4	82 x 90,4	1910	2	22,6	46-48	63-65	52
223 A7.000	D (A) 4	82 x 90,4	1910	2	18,5	77	105	53
223 A9.000	D (A) 4	69,6 x 82	1248	4	17,6	62	84	9
223 B1.000	D (A) 4	82 x 90,4	1910	2	18,5	77	105	53
223 B2.000	D (A) 4	82 x 90,4	1910	2	18,5	74	100	51
230 A2.000	D (NA) 4	82,6 x 90	1929	2	20	51	70	60
263 A1.000 Euro 5	D (LA) 4	83 x 90,4	1956	4	16,5	99	135	69
263 A2.000 Euro 5	D (A) 4	69,6 x 82	1248	4	16,8	66	90	11
263 A3.000 Euro 5	D (A) 4	79,5 x 80,5	1598	4	16,5	74	101	36
280 A1.000	D (A) 4	82,6 x 90	1929	2	20	60	82	61
350 A1.000 Euro 4/5	B (NA) 4	72 x 84	1368	2	11	51-63	69-86	20
350 A2.000 Euro 5	D (A) 4	79,5 x 80,5	1598	4	16,5	85-88	116-120	35
4.107	D (NA) 4	79,37 x 88,9	1760	2	22,1	30-40	41-55	32
4.203	D (NA) 4	91,48 x 126,9	3335	2	17,4:1	44	60	102
4.236	D (NA) 4	98,43 x 127	3866	2	16:1	55-65	75-88	126
4.248	D (NA) 4	100,96 x 127	4067	2	16:1	53-66	72-90	128
4HP	D (A) 4	85 x 96	2179	4		120	163	83
4HR	D (A) 4	85 x 96	2179	4	17,6:1	120	163	83
4HT (DW12BTED4) Euro 4	D (A) 4	85 x 96	2179	4	16,6	125	170	82
4HW (DW12ATED4)	D (A) 4	85 x 96	2179	4	18	94	128	80
4HX (DW12TED4)	D (LA) 4	85 x 96	2179	4		94-100	128-136	83
4P10-T3 Euro 5	D (A) 4	95,8 x 104	2998	4		107	145	124
6.372.4	D (NA) 6	101,05 x 126,8	6100	2	16:1	82-87	112-118	129
8025.01	D	95 x 110	1560	2	17:1	18	25	119
8025.02	D	100 x 110	1727	2	17:1	24	32	127

F

			Cyl.		mm	cm <sup>3</sup>		Comp. Ratio	€	kW	PS	Pos
8030.00			D (NA) 3		95 x 110	2340	2	17:1		28-38	38-51	119
8030.01			D 3		95 x 110	2340	2	17:1		28-37	38-51	119
8030.02			D (NA) 3		100 x 110	2592	2	17:1		46	62	127
8035.01	303		D 3		95 x 110	2338	2	17:1		28-35	38-48	119
8035.02	201, 202, 210, 212, 261, 265, 276, 300, 302, 310, 312, 350, 353, 355, 356, 361, 365, 376		D 3		100 x 110	2592	2	17:1		29-46	39-62	127
8035.04	265, 270, 272, 300, 359, 376, 378		D (NA) 3		103 x 110	2749	2	17:1		35-43	48-58	133
8035.05	200, 206, 208, 265, 306, 307, 308, 309		D 3		104 x 115	2931	2	17:1		42-44	57-60	136
8035.06	200, 206, 208, 216, 220, 222, 223, 306, 307, 308, 309, 317, 320, 321, 322, 323		D (NA) 3		100 x 115	2708	2	17:1		33-41	45-56	127
8040.00			D (NA) 4		95 x 110	3120	2	17:1		51	70	119
8040.02	041, 267, 300, 360, 367		D (NA) 4		100 x 110		2	17:1		56-60	76-82	127
8040.04	200, 280		D (NA) 4		103 x 110	3666	2	17:1		63	85-86	133
8040.05	200, 230		D (NA) 4		104 x 115	3908	2	17:1		65	88	136
8040.25	200, 207, 208, 220		D (A) 4		104 x 115	3908	2	17:1		85	115-116	136
8040.25B	4200 (LTC)		D (A) 4		104 x 115	3908	2	17,7:1		75	102	136
8040.25X	4000		D (A) 4		104 x 115	3908	2	17,7:1		85	116	136
8040.45 Euro 2	5200, 5281		D (LA) 4		104 x 115	3908	2	18:1		100	136	136
8040.45	4000 (TCA), 4180 (TCA)		D (LA) 4		104 x 115	3908	2			100	136	136
8040.45D Euro 2	5100, 5103		D (LA) 4		104 x 115	3908	2	18:1		85	116	136
8045.01			D 4		95 x 110	3120	2	17:1		40-54	52-70	119
8045.02	200, 211, 270, 276, 354, 356, 358, 359, 370, 376		D 4		100 x 110	3456	2	17:1		47-52	64-70	127
8045.04	189, 270, 275, 276, 293, 300, 359, 370, 376		D (NA) 4		103 x 110	3666	2	17:1		48-57	65-78	133
8045.05	205, 206, 207, 208, 209, 306, 307, 309		D 4		104 x 115	3908	2	17:1		57-59	78-80	136
8045.05	200, 204, 216, 217, 300, 304, 308, 317, 359, 389, 393, 395		D (NA) 4		104 x 115	3908	2	17:1		57-60	78-82	136
8045.06	200, 208, 213, 225, 319, 326		D (NA) 4		100 x 115	3613	2	17:1		48-51	65-69	127
8045.06	216, 219, 220, 301, 306, 307, 308, 309, 317, 320, 321		D 4		100 x 115	3613	2	17:1		48-51	65-70	127
8055.04	200, 205, 250		D (NA) 5		103 x 110	4583	2	17:1		60-66	82-90	133
8055.05	000		D (NA) 5		104 x 115	4885	2	17:1		66	90	136
806.000			D 6		95 x 110	4678	2	17:1		66-81	90-110	119
8060.01			D 6		95 x 110	4678	2	17:1		66-81	90-110	119
8060.02	000, 001, 003, 070		D (NA) 6		100 x 110	5184	2	17:1		90	122	127
8060.04	051, 055, 060, 660, 660		D (NA) 6		103 x 110		2			95-102	130-139	133
8060.05	200, 200, 246, 270, 270, 280, 280, 285, 289		D (NA) 6		104 x 115	5861	2			99-102	135-139	136
8060.24	001, 601		D (A) 6		103 x 110	5499	2	17:1		124	168-169	134
8060.25	4600		D (A) 6		103 x 110	5499	2	17,7:1		130	177	135
8060.25 Euro 2	000		D (LA) 6		104 x 115	5863	2	16,5:1		130	177	136
8060.25	400, 420, 600		D (A) 6		104 x 115		2			130	175-177	136
8060.25R Euro 1	4200, 4280		D (LA) 6		104 x 115	5861	2	17,7:1		105	143	136
8060.25V Euro 1	4000, 4080		D (LA) 6		104 x 115	5861	2	17,7:1		130	177	136
8060.45	600		D (LA) 6		104 x 115	5861	2	17:1		152	207	136
8060.45 Euro 1	4100, 4180, 6000, 6090		D (LA) 6		104 x 115		2			152-167	207-227	136
8060.45B Euro 2	5160		D (LA) 6		104 x 115	5863	2	18:1		130	177	136
8060.45K Euro 2	6096		D (LA) 6		104 x 115	5863	2	18:1		167	227	136
8060.45M Euro 2	7280		D (LA) 6		104 x 115	5863	2	18:1		179	240	136
8060.45R Euro 2	5046		D (LA) 6		104 x 115	5863	2	18:1		105	143	136
8060.45S Euro 1	6000, 6070, 6700, 6800		D (LA) 6		104 x 115		2	17:1		167	227	137
8060.45X Euro 2	4182		D (LA) 6		104 x 115	5863	2	17:1		152	207	136
8065.01	000		D 6		95 x 110	4678	2	17:1		66-81	90-110	119
8065.02	200, 217		D (NA) 6		100 x 110	5184	2	17:1		70-74	95-101	127
8065.04	089, 095, 097, 200, 270		D (NA) 6		103 x 110	5499	2	17:1		53-85	72-116	133
8065.05	000, 220		D (NA) 6		104 x 115	5863	2	18:1		81-85	110-116	136
8065.06	200, 300		D (NA) 6		100 x 115	5418	2	17:1		72-74	98-100	127
8065.24	000, 091, 092, 098, 300		D (NA) 6		103 x 110	5499	2	16,5:1		85-99	115-135	133
8065.25	010		D (NA) 6		104 x 115	5863	2	16,5:1		94-96	128-131	136
8065.25	220		D (A) 6		104 x 115	5863	2	17:1		95	130	136
8140.07 Euro 1	3731		D (LA) 4		93 x 92	2499	2	19:1		53	72	104
8140.07 Euro 1	3700		D (NA) 4		93 x 92	2499	2	19:1		53	72	111
8140.07	2530, 2731		D 4		93 x 92	2499	2	18,5:1		55	75	104
8140.21	235		D (A) 4		93 x 90	2445	2	18:1		68	92	104
8140.23 Euro 2	3700		D (A) 4		94,4 x 100	2798	2	18,5:1		76	103	115
8140.23 Euro 2	3900		D (LA) 4		94,4 x 100	2798	2	18,5:1		76	103	117
8140.23 Euro 2	3761, 3861		D (LA) 4		94,4 x 100	2798	2	18,5:1		76	103	115
8140.23 Euro 2	2585		D (A) 4		94,4 x 100	2798	2	18,5:1		76-78	103-106	116

F







	Cyl.	X mm	cm <sup>3</sup>	Comp. Ratio $\epsilon$	kW	PS	Pos
F3 BEE 681 G Euro 4	D (LA) 6	135 x 150	12882	4 16,5:1	280	381	144
F3 BEE 681 V Euro 4	D (LA) 6	135 x 150	12882	4 16,5:1	310	421	144
F3AE0681B Euro 3	D (LA) 6	125 x 140	10308	4 17:1	294	400	143
F3AE0681E Euro 2	D (LA) 6	125 x 140	10308	4 17:1	287	390	143
F4 AE 0481 B Euro 3	D (LA) 4	102 x 120	3922	4 17:1	125	170	130
F4 AE 3682 A Euro 4	D (LA) 6	102 x 120	5883	4			131
F4 AE 3682 B Euro 4	D (LA) 6	102 x 120	5883	4			131
F4 AE 3682 C Euro 4	D (LA) 6	102 x 120	5883	4			131
F4 AE 3682 E Euro 4	D (LA) 6	102 x 120	5883	4	194	264	131
F4AE0684C Euro 3	D (LA) 6	102 x 120	5883	4 17,5	169	230	131
F4AE3481A Euro 4/5	D (LA) 4	102 x 120	3922	4	130-134	177-182	132
F4AE3481B Euro 4/5	D (LA) 4	102 x 120	3922	4	130	177	132
F4AE3481C Euro 4/5	D (LA) 4	102 x 120	3922	4	103	140	132
F4AE3481D Euro 4/5	D (LA) 4	102 x 120	3922	4	118	160	132
LFW (XU7JP) Euro 2	B (NA) 4	83 x 81,4	1761	2 9,5	73	99	64
M202 AA.13.0	B 4	86,4 x 55,5	1301	2 9,1:1	55	75	91
M605 AA.15.000	B 4	86,4 x 63,9	1498	2 9,2:1	55	75	91
M607 AA.18.0	B 4	84 x 79,2	1756	4 9,9:1	101	138	73
M705 BA.19.0	D 4	82,6 x 90	1929	2 20:1	27	37	60
M707 AT.19.0	D (LA) 4	82,6 x 90	1929	2 20:1	59	80	60
R9M 408	D (A) 4	80 x 79,5	1598	4 15,4	66-85	90-116	39
R9M 413	D (A) 4	80 x 79,5	1598	4 15,4	70-89	95-121	39
R9M 450	D (A) 4	80 x 79,5	1598	4 15,4	88-103	120-140	39
R9M 452	D (A) 4	80 x 79,5	1598	4 15,4	92-107	125-145	39
RFN (EW10J4)	B (NA) 4	85 x 88	1997	4 10,8	100	136	74
RFV	B (NA) 4	86 x 86	1998	4 10,4	97-100	132-136	87
RGX (XU10J2CTE)	B (A) 4	86 x 86	1998	2 8,5	108	147	86
RHH Euro 5	D (A) 4	85 x 88	1997	4 16	120	163	84
RHK Euro 4	D (A) 4	85 x 88	1997	4 17,5	88	120	77
RHK (DW10UTED4) Euro 4	D (LA) 4	85 x 88	1997	4 17,5	79-88	107-120	75
RHM (DW10ATED4)	D (A) 4	85 x 88	1997	4 17,6:1	79-80	107-109	77
RHR	D (A) 4	85 x 88	1997	4 18	100	136	81
RHW (DW10ATED4)	D (A) 4	85 x 88	1997	4 18	80	109	76
RHX	D (A) 4	85 x 88	1997	2 17,6	69	94	78
RHZ	D (A) 4	85 x 88	1997	2 17,6	80	109	79
WJY (DW8) Euro 2	D (NA) 4	82,2 x 88	1868	2 23	51	69	58
WJY (DW8B) Euro 2	D (NA) 4	82,2 x 88	1868	2 23	51	69	59
WJZ (DW8) Euro 2	D (NA) 4	82,2 x 88	1868	2 23	51-52	69-71	59
XFW	B (NA) 6	87 x 82,6	2946	4 10,9	150-152	204-207	96

						Pos							Pos
							1.6i 16V	01.2002 →	178 C7.098	B		95	
							1.6i 16V	01.2002 →	182 B6.000	B		42	
<b>126 (126_)</b>							<b>ARGENTA (132_)</b>						
600	09.1972 → 06.1977	126 A.000	B	24	1600	04.1981 → 12.1985	132 D.000	B		70			
650	07.1977 → 09.1987	126 A1.000	B	30	1600 i.e	04.1981 → 12.1985	132 D.000	B		70			
<b>127 (127_)</b>							2000	06.1978 → 12.1985	132 D1.000	B		70	
0.9	06.1971 → 05.1983	100 GL.048	B	1	2500 Diesel	06.1981 → 11.1985	8144.61	D		104			
0.9 (127A)	09.1971 → 12.1984	100 GL.000	B	1	2500 Turbodiesel	07.1983 → 08.1985	8144.61.500.81	D		107			
<b>131 (131_)</b>							<b>AVVENTURA (199)</b>						
1.4 Mirafiori	11.1980 → 01.1984	131 C1.000	B	31	1.3 JTD Multijet	10.2014 → 12.2019	199 A2.000	D		7			
1.4 Super Mirafiori	04.1981 → 12.1983	131 C1.000	B	31	1.4 T-Jet	01.2016 → 12.2019	198 A1.000	B		23			
1.6 Super Mirafiori (A)	03.1979 → 03.1982	131 B1.000	B	70	<b>BARCETTA (183)</b>								
2.0 D	03.1978 → 03.1987	8144.65	D	98	1.2i 16V	12.1998 → 05.2005	182 B2.000	B		18			
2.0 Super	01.1981 → 12.1984	131 C4.000	B	70	1.4i 12V	10.1995 → 05.2005	182 A5.000	B		48			
2.5 D	06.1978 → 02.1984	8144.61	D	104	1.6i 16V	10.1995 → 05.2005	182 A6.000	B		93			
<b>131 Familiare/Panorama (131_)</b>							1.9 TD	03.1996 → 05.2005	182 A7.000	D	50		
1.4 Mirafiori	11.1981 → 01.1984	131 C1.000	B	31	1.9 TD	03.1996 → 05.2005	182 A8.000	D		50			
2.0 D	07.1978 → 08.1984	8144.65	D	98	<b>BARCETTA (183_)</b>								
2.0 Super	01.1981 → 12.1984	131 C4.000	B	70	1.8 16V	04.1995 → 05.2005	183 A1.000	B		45			
2.5 Super Diesel (AF)	03.1979 → 12.1984	8144.61	D	104	1.8 16V	05.1998 → 05.2005	188 A6.000	B		45			
<b>132 (132_)</b>							<b>BRAVA (182_)</b>						
2.0 D	07.1978 → 07.1982	8144.65	D	98	1.2 16V 80	12.1998 → 12.2002	182 B2.000	B		18			
2.5 D	07.1978 → 07.1982	8144.61	D	104	1.2 16V 80	10.2000 → 10.2001	188 A5.000	B		18			
<b>133 (133_)</b>							1.4 (182.BG)	10.1995 → 10.2001	182 A5.000	B	48		
133	05.1974 → 1977	100 GL6.000	B	1	1.4 12 V (182.BA)	10.1995 → 08.1998	182 A3.000	B		47			
<b>147 (147_)</b>							1.6 16V	04.2000 → 06.2003	182 B6.000	B	42		
0.9	04.1977 → 12.1981	100 GL.000	B	1	1.6 16V (182.BB)	02.1996 → 10.2001	182 A4.000	B		94			
1.0	11.1976 → 02.1987	156 A.000	B	28	1.6 16V (182.BB)	08.1999 → 03.2000	182 A4.000	B		94			
<b>500 (111_, 101_, 110_)</b>							1.6 16V (182.BH)	10.1995 → 10.2001	182 A6.000	B	93		
0.5 (110F)	01.1965 → 12.1975	110 F.000	B	6	1.6 16V (182.BU)	01.1999 → 12.2002	182 B6.000	B		42			
0.5 (110F)	01.1965 → 12.1975	120.000	B	6	1.8 16V	02.2000 → 06.2003	183 A1.000	B		45			
<b>500 (312_)</b>							1.8 GT 16V (182.BC)	10.1995 → 08.2001	182 A2.000	B	45		
1.2 (312AXA1A)	07.2007 →	169 A4.000	B	19	1.9 D	10.1995 → 10.2001	160 A7.000	D		60			
1.2 LPG (312AXA1A)	12.2010 →	169 A4.000	B	19	1.9 JTD	09.2000 → 10.2001	182 B9.000	D		51			
1.3 D Multijet (312AXB1A)	10.2007 →	169 A1.000	D	7	1.9 JTD 105	12.1998 → 10.2001	182 B4.000	D		52			
1.3 D Multijet (312AXE1A)	12.2009 →	199 B1.000	D	12	1.9 TD 100 S (182.BF)	03.1996 → 10.2001	182 A7.000	D		50			
1.4 (301J410)	09.2008 →	169 A3.000	B	21	1.9 TD 75 S (182.BF)	03.1996 → 10.2001	182 A8.000	D		50			
1.4 (301J410)	02.2009 →	169 A3.000	B	21	<b>BRAVO I (182_)</b>								
1.4 (312AXC1B, 312CXC1B)	10.2007 →	169 A3.000	B	21	1.2 16V 80	12.1998 → 10.2000	182 B2.000	B		18			
1.4 Flex (3019530)	08.2011 →	169 A3.000	B	21	1.2 16V 80	10.2000 → 10.2001	188 A5.000	B		18			
<b>500 C (312_)</b>							1.4 (182.AA)	10.1995 → 10.2001	182 A3.000	B	47		
1.2 (312CXA1A, 312AXA1A)	09.2009 →	169 A4.000	B	19	1.4 (182.AG)	10.1995 → 10.2001	182 A5.000	B		48			
1.3 D Multijet (312CXB1A)	09.2009 →	169 A1.000	D	7	1.6	09.2000 → 10.2001	182 B6.000	B		42			
1.3 D Multijet (312CXE1A, 312AXE1A)	09.2009 →	199 B1.000	D	12	1.6 16V (182.AB)	03.1996 → 10.2001	182 A4.000	B		94			
1.4 (301J410)	08.2011 →	169 A3.000	B	21	1.6 16V (182.AH)	10.1995 → 10.2001	182 A6.000	B		93			
1.4 (301J410)	09.2011 →	169 A3.000	B	21	1.8 GT (182.AC)	10.1995 → 10.2001	182 A2.000	B		45			
1.4 (312CXC1B, 312AXC1B)	09.2009 →	169 A3.000	B	21	1.9 D	10.1995 → 10.2001	160 A7.000	D		60			
1.4 Flex (3010B6)	08.2011 → 12.2015	169 A3.000	B	21	1.9 JTD	09.2000 → 10.2001	182 B9.000	D		51			
<b>500 Estate (101_)</b>							1.9 JTD 105	12.1998 → 10.2001	182 B4.000	D	52		
0.5	01.1960 → 12.1966	120.000	B	6	1.9 TD 100 S (182.AF)	03.1996 → 10.2001	182 A7.000	D		50			
<b>500L (351_, 352_)</b>							1.9 TD 75 S (182.AF)	03.1996 → 10.2001	182 A8.000	D	50		
1.3 D Multijet (199LXY1A, 199LXY11)	09.2012 →	199 B4.000	D	12	2.0 HGT 20V (182.AD)	10.1995 → 07.1998	182 A1.000	B		46			
1.4 (199LYB1B)	09.2012 →	843 A1.000	B	21	2.0 HGT 20V (182.AQ)	07.1998 → 10.2001	182 B7.000	B		45			
1.6 D Multijet (199LYE1B)	09.2013 →	955 A3.000	D	35	<b>BRAVO II (198_)</b>								
<b>850 (100_)</b>							1.4 (198AXA1B)	04.2007 → 12.2014	192 B2.000	B	21		
0.9	02.1968 → 12.1972	100 GBC.000	B	1	1.4 LPG (198AXA1B)	12.2008 → 12.2014	192 B2.000	B		21			
0.9	02.1968 → 12.1972	100 GBC.040	B	1	1.4 T-Jet (198257)	06.2011 → 12.2016	198 A1.000	B		23			
<b>ALBEA</b>							1.4 T-Jet (198AXF1B)	09.2007 → 12.2014	198 A1.000	B	23		
1.2i	04.2003 →	188 A4.000	B	17	1.4 T-Jet (198AXG1B)	10.2007 → 12.2014	198 A4.000	B		23			
1.2i 16V	01.2002 →	188 A5.000	B	18	1.6 D Multijet (198AXH1B)	09.2007 → 12.2014	198 A3.000	D		33			
1.4i	01.2007 →	199 A1.000	D	11	1.6 D Multijet (198AXL1B)	03.2008 → 12.2014	198 A2.000	D		35			
					1.6 D Multijet (198AXM1B)	03.2008 → 12.2014	198 A6.000	D		34			
					1.9 D Multijet (198AXB1A)	04.2007 → 12.2014	192 A8.000	D		51			
					1.9 D Multijet (198AXC1B)	04.2007 → 12.2014	937 A5.000	D		55			

F

		Pos			Pos				
1.9 D Multijet (198AXD1A)	11.2006 → 12.2009	192 A1.000	D	51	1.7 DS	01.1987 → 12.1991	149 B3.000	D	61
2.0 D Multijet (198AXN1B)	09.2008 → 12.2014	198 A5.000	D	69	<b>ELBA (146_)</b>				
2.0 D Multijet (198AXPIB)	09.2008 → 12.2014	844 A2.000	D	69	1.6	02.1990 → 04.1993	159 A3.000	B	91
<b>CAMPAGNOLA (110_)</b>					1.7 D	04.1989 → 12.1996	146 B2.000	D	60
2.4 D	06.1974 → 10.1989	8144.61.200	D	104	1.7 D	04.1991 → 10.1997	146 B2.000	D	60
<b>CINQUECENTO (170_)</b>					<b>FIORINO MPV (146_)</b>				
0.9 (170AB)	07.1991 → 12.1993	170 A1.000	B	3	1.7 (146CI)	01.1988 → 10.1992	146 B2.000	D	60
0.9 i.e. (170AC)	07.1991 → 09.1994	170 A1.046	B	4	<b>FIORINO MPV (225_)</b>				
0.9 i.e. S (170AF, 170CF)	07.1991 → 07.1999	1170 A1.000	B	3	1.4 (225AXA1A)	07.2014 →	350 A1.000	B	20
0.9 i.e. S (170AF, 170CF)	07.1991 → 07.1999	1170 A1.046	B	4	1.4 CNG (225AXC1A)	07.2014 →	350 A1.000	B	20
1.1 Sporting (170AH)	10.1994 → 01.1998	176 B2.000	B	14	1.4 CNG (225AXC1A, 225BXC1A)	06.2008 →	350 A1.000	B	20
<b>COUPE (175_)</b>					JTD Multijet	11.2007 →	199 A2.000	D	7
1.8 16V	03.1996 → 08.2000	183 A1.000	B	45	(225BXB1A, 225BXB11)				
2.0 16V	11.1993 → 08.1996	836 A3.000	B	72	JTD Multijet	11.2007 →	199 A9.000	D	12
2.0 16V Turbo	11.1993 → 08.1996	175 A1.000	B	72	(225BXB1A, 225BXB11)				
2.0 20V	05.1998 → 08.2000	182 B3.000	B	46	JTD Multijet	01.2011 →	199 B1.000	D	12
2.0 20V (175AXC1A)	08.1996 → 09.1998	182 A1.000	B	46	(225BXC1A)				
2.0 20V Turbo	08.1996 → 08.2000	175 A3.000	B	46	<b>FIORINO Pick up (146_)</b>				
<b>CROMA (154_)</b>					1.7 D	05.1988 → 12.1991	149 B3.000	D	61
2000 16V	08.1992 → 08.1996	154 E1.000	B	72	1.7 D	10.1993 → 10.1999	146 B2.000	D	60
2000 CHT	01.1991 → 09.1992	154 A1.000	B	70	1.7 TD	01.1997 → 05.2001	146 D7.000	D	60
2000 CHT (154.AC)	12.1985 → 02.1989	154 A1.000	B	70	<b>FIORINO Pick up (147_)</b>				
2000 i.e. (154.AD)	03.1987 → 09.1992	834 B.000	B	71	1.0	06.1982 → 10.1987	127A.046	B	29
2500 TD (154.AE)	12.1985 → 08.1989	8144.91.2000	D	108	1.0	12.1986 → 10.1989	156 A.000	B	28
2500 TD (154.LL, 154.PL)	05.1989 → 08.1996	8144.97	D	109	<b>FREEMONT (345_)</b>				
2500 TD (154.LL, 154.PL)	05.1989 → 08.1996	8144.97 Y	D	109	2.0 JTD	08.2011 →	939 B5.000	D	69
2500 TDE	12.1991 → 08.1996	8144.97 S	D	108	2.0 JTD	08.2011 →	939 B5.000	D	69
2500 V6	06.1993 → 08.1996	834 G.000	B	97	2.0 JTD	08.2011 →	939 B5.000	D	69
<b>CROMA (194_)</b>					2.0 JTD	08.2011 →	939 B5.000	D	69
1.8 16V	12.2005 →	939 A4.000	B	43	2.0 JTD	08.2011 →	939 B5.000	D	69
1.9 D Multijet (194AXB1B)	06.2005 → 12.2011	939 A1.000	D	56	2.0 JTD	08.2011 →	940 A5.000	D	69
1.9 D Multijet (194AXC1B, 194AXC12)	06.2005 → 12.2011	939 A2.000	D	55	2.0 JTD	08.2011 →	940 A5.000	D	69
2.2 16V	06.2005 →	194 A1.000	B	88	2.0 JTD 4x4	08.2011 →	939 B5.000	D	69
2.4 D Multijet	06.2005 →	939 A3.000	D	57	2.0 JTD 4x4	08.2011 →	939 B5.000	D	69
<b>DOBLO (119/223)</b>					2.0 JTD 4x4	08.2011 →	940 A5.000	D	69
1.2i 16V		176 B9.000	B	18	<b>GRANDE PUNTO (199_)</b>				
<b>DOBLO MPV (119 , 223_)</b>					1.2	10.2005 →	199 A4.000	B	19
1.2 (223AXA1A)	03.2001 →	223 A5.000	B	17	1.2	09.2010 →	169 A4.000	B	19
1.3 D Multijet	10.2005 →	223 A9.000	D	9	1.2 LPG (199BXA1A, 199AXA1A)	06.2008 → 12.2012	199 A4.000	B	19
1.3 JTD	05.2005 →	199 A2.000	D	7	1.3 D Multijet	10.2005 →	199 A2.000	D	7
1.3 JTD 16V	12.2004 → 05.2005	188 A9.000	D	7	1.3 D Multijet	07.2008 →	199 B2.000	D	12
1.4	10.2005 →	350 A1.000	B	20	1.3 D Multijet	06.2009 → 07.2014	199 A2.000	D	7
1.6	09.2002 →	182 B6.000	B	42	1.3 D Multijet	04.2010 →	199 B4.000	D	12
1.6 16V	03.2001 → 08.2003	182 B6.000	B	42	1.3 D Multijet	04.2010 →	223 A9.000	D	9
1.6 16V (223AXD1A)	10.2001 →	182 B6.000	B	42	1.3 D Multijet	01.2012 → 01.2013	199 A2.000	D	7
1.6 Natural Power	09.2002 →	182 B6.000	B	42	1.3 D Multijet	10.2005 → 12.2010	199 A3.000	D	9
1.6 Natural Power (223AXD1A)	11.2005 → 07.2009	182 B6.000	B	42	(199.AXD11, 199.AXD1A, 199.AXD1B,...)				
1.9 D (223AXB1A)	03.2001 →	223 A6.000	D	52	1.4 (199AXB11, 199AXB1A, 199BXB1A, 199AXL1A)	06.2005 → 12.2015	350 A1.000	B	20
1.9 D Multijet	10.2005 →	186 A9.000	D	51	1.4 (199AXB1A)	10.2005 → 07.2007	199 A7.000	B	22
1.9 JTD	07.2003 →	223 A7.000	D	53	1.4 16V	09.2007 → 07.2012	198 A1.000	B	23
1.9 JTD	07.2003 →	223 B1.000	D	53	1.4 16V (199BXG1B, 199AXG1B)	10.2005 → 08.2011	199 A6.000	B	21
1.9 JTD (223AXE1A)	10.2001 →	182 B9.000	D	51	1.4 LPG	12.2008 →	350 A1.000	B	20
1.9 JTD (223AXE1A)	10.2001 →	223 B2.000	D	51	1.4 Natural Power	07.2008 →	350 A1.000	B	20
<b>DUNA (146_)</b>					1.4 T-Jet (199AXM1A, 199BXM1A, 199BXN1A)	09.2007 →	198 A4.000	B	23
1.7 DS	01.1987 → 12.1991	149 B3.000	D	61	1.6 D Multijet	07.2008 →	955 A3.000	D	35
<b>DUNA Saloon (146_)</b>					1.9 D Multijet	10.2005 →	199 A5.000	D	51
1.1	07.1991 → 07.1996	146 A4.048	B	37	1.9 D Multijet	10.2005 →	939 A1.000	D	56
1.5	04.1988 → 12.1995	138 B3.000	B	91	<b>IDEA (350_)</b>				
1.6	02.1996 → 09.2000	159 A3.000	B	91	1.2 16V	01.2004 →	188 A5.000	B	18
1.7 D	01.1999 → 10.2001	149 B3.000	D	61	1.3 D Multijet	01.2004 →	188 A9.000	D	7
<b>DUNA Weekend (146_)</b>					1.3 D Multijet	10.2005 →	199 A3.000	D	9
1.7 DS	01.1987 → 12.1991	146 B2.000	D	60	1.3 D Multijet	05.2008 → 12.2012	199 B1.000	D	12
					1.4	12.2003 →	192 B2.000	B	21

				Pos					Pos
1.4	10.2005 →	350 A1.000	B	20	1.9 TD	01.1997 → 02.1999	182 A7.000	D	50
1.4 16V	01.2004 →	843 A1.000	B	21	1.9 TD	03.1999 → 09.2002	182 A8.000	D	50
1.4 LPG	03.2009 →	350 A1.000	B	20	2.5 D	05.1980 → 09.1983	8144.61	D	104
1.6 D Multijet	05.2008 →	350 A2.000	D	35	2.5 D	05.1980 → 09.1983	8144.61.200	D	104
1.9 JTD	01.2004 →	188 B2.000	D	51	<b>MULTIPLA (186_)</b>				
<b>LINEA (323_, 110_)</b>					1.6	05.2004 → 08.2005	182 B6.000	B	42
1.3 D Multijet	11.2008 → 12.2019	199 A3.000	D	9	1.6 (186AXC1A)	03.2001 → 08.2005	182 B6.000	B	42
1.3 D Multijet	06.2007 →	199 A3.000	D	9	1.6 (186AXC1A,	09.2000 → 06.2010	182 B6.000	B	42
(323AXB11, 323AXB1A)					186BMC1A, 186BXC1A)				
1.3 D Multijet	09.2009 →	199 A3.000	D	9	1.6 100 16V	04.1999 → 06.2010	182 A4.000	B	94
(323AXB1A)					(186AXA1A)				
1.3 D Multijet	09.2009 →	199 B1.000	D	12	1.6 16V	04.1999 → 04.2002	182 A4.000	B	94
(323AXB1A)					1.6 16V (186AGB1A)	04.2002 → 06.2010	182 B6.000	B	42
1.3 JTD Multijet	10.2006 →	199 A3.000	D	9	1.6 16V Bipower	04.1999 → 06.2010	186 A4.000	BG	89
(323AXB1A)					(186AMB1A)				
1.4	06.2007 →	350 A1.000	B	20	1.6 16V Bipower	10.2001 → 06.2010	182 B6.000	B	42
1.4 T-Jet	10.2008 → 12.2012	198 A1.000	B	23	(186AXC1A)				
1.4 T-Jet (323AXC1A)	05.2007 →	198 A4.000	B	23	1.6 16V Blupower	04.1999 → 06.2010	186 A3.000	BG	90
1.6 D Multijet	06.2009 →	198 A3.000	D	33	(186AMA1A)				
<b>MAREA (185_)</b>					1.6 16V GPL	10.2001 → 06.2010	182 B6.000	B	42
1.2 16V	10.1998 → 05.2002	182 B2.000	B	18	1.6 Natural Power	11.2008 → 06.2010	182 B6.000	B	42
1.4 80 12V	09.1996 → 05.2002	182 A3.000	B	47	(186AGB1A05)				
1.6	01.2000 → 08.2000	185 A3.000	BG	89	1.9 JTD (186AXE1A)	04.2002 → 06.2010	186 A9.000	D	51
1.6	09.2000 → 08.2002	182 B6.000	B	42	1.9 JTD 105	04.1999 → 06.2010	182 B4.000	D	52
1.6	06.2005 → 12.2007	182 B6.000	B	42	(186AXB1A)				
1.6 100 16V	09.1996 → 05.2002	182 A4.000	B	94	1.9 JTD 110	03.2001 → 07.2002	186 A6.000	D	51
1.6 100 16V Bipower	04.1999 → 05.2002	186 A4.000	BG	89	1.9 JTD 115	07.2002 → 06.2010	186 A8.000	D	52
1.6 100 16V Bipower	01.2000 → 05.2002	185 A3.000	BG	89	<b>PALIO (178 BX7DX)</b>				
1.6 16V	04.1997 → 02.1999	185 A3.000	BG	89	1.3 JTD	07.2003 →	188 A9.000	D	7
1.8	09.1996 → 12.2007	183 A1.000	B	45	1.7 D	03.1998 →	176 B3.000	D	60
1.8 115 16V	09.1996 → 05.2002	182 A2.000	B	45	<b>PALIO (178_)</b>				
1.9 JTD	01.2001 → 12.2007	182 B4.000	D	52	1.1	06.2006 → 11.2011	187 A1.000	B	15
1.9 JTD	01.2001 → 12.2007	182 B9.000	D	51	1.2	07.1997 → 08.2002	188 A4.000	B	17
1.9 JTD 105	12.1998 → 12.2002	182 B4.000	D	52	1.2	06.1998 →	176 A8.000	B	16
(185AXN1A)					1.2	06.1998 →	178 E2.000	B	17
1.9 JTD 110 (185AXT1A)	09.2000 → 08.2002	186 A6.000	D	51	1.2	06.1999 → 10.2000	178 E2.000	B	17
1.9 TD 100 (185AX_)	05.1996 → 12.2002	182 A7.000	D	50	1.2 (178BYE1AAT)	06.2001 → 10.2007	188 A5.000	B	18
1.9 TD 75	09.1996 → 05.2002	182 A8.000	D	50	1.3 D Multijet	03.2008 → 11.2011	188 A9.000	D	7
2.0 150 20V	09.1996 → 04.1999	182 A1.000	B	46	1.3 JTD Multijet	06.2003 → 01.2012	188 A9.000	D	7
2.0 150 20V	01.2001 → 05.2002	185 A8.000	B	49	(178BYE1AAT)				
2.0 155 20V	04.1999 → 01.2001	182 B7.000	B	45	1.4	10.2005 →	350 A1.000	B	20
2.4 JTD 130	04.1999 → 05.2002	185 A6.000	D	52	1.4 (178BXA1A)	10.2002 → 10.2004	350 A1.000	B	20
2.4 JTD 130	04.1999 → 05.2002	839 A5.000	D	52	1.6	06.1996 → 01.2012	182 B6.000	B	42
2.4 TD 125	09.1996 → 04.1999	185 A2.000	D	50	1.6	06.1999 →	178 D2.011	B	95
<b>MAREA Weekend (185_)</b>					1.6	06.2006 →	178 E7.000	B	44
1.2 16V	10.1998 → 05.2002	182 B2.000	B	18	1.6	06.2006 →	182 B6.000	B	42
1.4 80 12V	09.1996 → 05.2002	182 A3.000	B	47	1.6	06.2006 →	182 B6.000	B	42
1.6	09.2000 → 08.2002	182 B6.000	B	42	1.6	06.2006 →	182 B6.000	B	42
1.6	06.2005 → 12.2007	182 B6.000	B	42	1.6 16V	04.1996 → 10.2002	178 B3.000	B	94
1.6 100 16V	09.1996 → 05.2002	182 A4.000	B	94	1.6 16V	06.1996 → 02.2003	178 B3.000	B	94
1.8	08.1999 → 12.2007	183 A1.000	B	45	1.6 16V	06.1996 → 02.2003	178 D2.011	B	95
1.8 115 16V	09.1996 → 05.2002	182 A2.000	B	45	1.6 16V	07.1997 → 10.2000	178 C7.098	B	95
1.9 JTD 105	12.1998 → 12.2002	182 B4.000	D	52	1.6 16V	07.1997 → 10.2000	178 D2.011	B	95
(185BXN1A)					1.7 D	04.1996 → 09.2002	176 B3.000	D	60
1.9 JTD 110 (185BXT1A)	09.2000 → 08.2002	186 A6.000	D	51	1.7 TD	02.1997 → 10.2003	176 A3.000	D	60
1.9 TD 100 (185BX_)	09.1996 → 06.2003	182 A7.000	D	50	1.7 TD	02.1997 → 10.2003	176 A5.000	D	63
1.9 TD 100 (185BX_)	09.1996 → 06.2003	182 B9.000	D	51	1.7 TD	09.2001 →	176 A3.000	D	60
1.9 TD 75	09.1996 → 05.2002	182 A8.000	D	50	1.7 TD	09.2001 →	176 A5.000	D	63
2.0 150 20V	09.1996 → 04.1999	182 A1.000	B	46	1.7 TD	10.2002 → 01.2012	176 A3.000	D	60
2.0 150 20V	01.2001 → 05.2002	185 A8.000	B	49	1.9 D (178BYU1A)	01.2003 →	223 A6.000	D	52
2.0 155 20V	04.1999 → 02.2003	182 B7.000	B	45	<b>PALIO Weekend (178_, 173_, 373_, 374_, 171_)</b>				
2.4 JTD 130	04.1999 → 05.2002	185 A6.000	D	52	1.2 (178BXZ1A)	06.1999 → 10.2002	178 E2.000	B	17
2.4 JTD 130	04.1999 → 05.2002	839 A5.000	D	52	1.2 (178DYA1A,	07.1997 → 10.2004	188 A4.000	B	17
2.4 TD 125	09.1996 → 04.1999	185 A2.000	D	50	178DXS1A)				
<b>MARENGO</b>					1.2 (178DYE1A,	09.2001 → 10.2004	188 A5.000	B	18
1.9 D	01.1986 → 07.1989	149 A1.000	D	60	178DYE1AAP,				
1.9 D	02.1990 → 12.1996	160 A7.000	D	60	178DYE1AAT)				
1.9 JTD	03.1999 → 09.2002	182 B4.000	D	52	1.3 (1788891, 1789491,	03.2000 → 02.2003	188 A5.000	B	18
1.9 JTD	08.2000 → 09.2002	186 A6.000	D	51	1730250)				
1.9 TD	02.1990 → 12.1996	160 A6.000	D	62	1.3 Multijet (178DXA1A)	04.2011 → 07.2011	188 A9.000	D	7
					1.6	07.1997 →	178 C7.098	B	95

F



		Pos			Pos		
1.6	01.2002 → 12.2007	178 D2.011 B	95	1.3 D Multijet	04.2015 →	199 B1.000 D	12
1.6 16V	07.1997 → 10.2003	178 C7.098 B	95	(312PXU1A, 312PXW1A)			
1.6 16V	07.1997 → 10.2003	178 D2.011 B	95	1.3 D Multijet 4x4	06.2012 →	199 A1.000 D	11
1.6 16V	02.2001 → 01.2012	182 B6.000 B	42	(312PXL1A)			
1.6 16V (178DXD1A)	06.1996 → 02.2001	178 B3.000 B	94	1.3 D Multijet 4x4	06.2012 →	199 A9.000 D	12
1.6 16V (178DXD1A)	02.1997 → 10.2001	178 B3.000 B	94	(312PXL1A)			
1.7 TD	04.1996 → 03.2001	176 A3.000 D	60	1.3 D Multijet 4x4	06.2014 →	199 A9.000 D	12
1.7 TD	07.1997 →	176 A5.000 D	63	(312PXS2A)			
1.7 TD	06.2001 → 03.2010	176 A5.000 D	63	1.3 D Multijet 4x4	04.2015 →	199 B1.000 D	12
1.9 D	03.2001 →	223 A6.000 D	52	(312PXU1A)			
1.9 D	03.2001 →	223 A6.000 D	52				
1.9 JTD	09.2001 →	188 A2.000 D	51				
<b>PANDA (141_)</b>							
1000	01.1985 → 12.1992	156 A3.000 B	14	1.2i 16V	03.2003 →	188 A5.000 B	18
1000	01.1986 → 04.1992	156 A2.100 B	15	1.6i 16V	03.2003 →	182 B6.000 B	42
1000 4x4	01.1986 → 07.1989	156 A2.100 B	15	<b>PREMIO (146_)</b>			
1000 4x4	01.1986 → 07.1989	156 A3.100 B	14	1.6	02.1990 → 04.1993	159 A3.000 B	91
1000 4x4	01.1986 → 12.1992	156 A3.000 B	14	<b>PUNTO (176_)</b>			
1000 4x4	05.1986 → 12.1994	156 A2.246 B	14	1.2 16V	04.1997 → 09.1999	176 B9.000 B	18
1000 i.e. Cat	10.1987 → 08.1998	156 A2.246 B	14	1.6	01.1994 → 04.1997	176 A9.000 B	92
1100	03.1992 → 12.1999	156 C.046 B	14	1.7 D	04.1996 → 09.1997	176 B3.000 D	60
1100	02.1995 → 09.2003	176 B2.000 B	14	1.7 TD	01.1994 → 09.1999	176 A3.000 D	60
1100	02.1995 → 09.2003	187 A1.000 B	15	1.7 TD	01.1994 → 09.1999	176 A5.000 D	63
1100 4x4	02.1995 → 07.2004	176 B2.000 B	14	1.7 TD (176AT)	09.1996 → 09.1999	176 B7.000 D	60
1100 Trekking 4x4	10.1991 → 07.2004	156 C.046 B	14	55 1.1	09.1993 → 09.1999	176 A6.000 B	14
750	01.1986 → 10.2003	156 A4.000 B	1	55 1.1	09.1993 → 09.1999	176 B2.000 B	14
800	02.1981 → 12.1985	100 GL6.000 B	1	60 1.2	01.1994 → 09.1999	176 A7.000 B	16
900	10.1980 → 06.1994	100 GL3.000 B	1	60 1.2 (176AP, 176AR, 176AQ, 176BB)	09.1993 → 09.1999	176 B1.000 B	16
900	10.1980 → 06.1994	146 A.000 B	2	60 1.2 (176AP, 176AR, 176AQ, 176BB)	09.1993 → 09.1999	176 B4.000 B	17
900	04.1992 → 12.1996	1170 A1.046 B	4	75 1.2	10.1993 → 09.1999	176 A8.000 B	16
950	09.1982 → 08.1983	A 112 B1.054 B	5	<b>PUNTO (188_)</b>			
950 4x4	09.1983 → 12.1986	A 112 B1.054 B	5	1.2 16V 80 (188.233, .235, .253, .255, .333, .353, .639,...)	09.1999 → 04.2006	188 A5.000 B	18
<b>PANDA (169_)</b>							
1.1 (169.AXA1A)	09.2003 →	187 A1.000 B	15	1.2 60 (188.030, .050, .130, .150, .230, .250)	09.1999 → 12.2010	188 A4.000 B	17
1.2 (169.AXB11, 169.AXB1A)	09.2003 →	188 A4.000 B	17	1.2 Bifuel	08.2007 → 03.2012	188 A4.000 B	17
1.2 (169.AXF2A, 169.AXF1A)	03.2010 → 08.2013	169 A4.000 B	19	1.2 Bipower (188BXA1A)	08.2001 → 05.2003	188 A4.000 B	17
1.2 4x4 (169.AXB2A)	10.2004 →	188 A4.000 B	17	1.2 Natural Power (188BXA1A)	09.2003 → 03.2012	188 A4.000 B	17
1.2 4x4 (169.AXF2A, 169.AXF1A)	04.2010 → 08.2013	169 A4.000 B	19	1.2 Natural Power (188BXA1A)	04.2004 → 04.2006	188 A4.000 B	17
1.2 LPG (169.AXB1A)	04.2009 →	188 A4.000 B	17	1.3 JTD 16V	06.2003 → 03.2012	188 A9.000 D	7
1.2 LPG (169.CXF1A)	11.2010 → 08.2013	169 A4.000 B	19	1.4	09.2003 → 03.2012	843 A1.000 B	21
1.2 Natural Power (169.AXB1A)	01.2007 → 12.2011	188 A4.000 B	17	1.4 (188AXM1A, 188BXM1A)	11.2005 → 03.2012	843 A1.000 B	21
1.3 D Multijet (169.AXC1A)	09.2003 →	188 A8.000 D	8	1.4 T-Jet	02.2009 → 07.2012	198 A1.000 B	23
1.3 D Multijet (169.AXG1A, 169.AXD1A)	06.2006 → 08.2013	169 A1.000 D	7	1.8 130 HGT (188.738, .718)	09.1999 → 03.2012	183 A1.000 B	45
1.3 D Multijet (169.AXG1A, 169.AXD1A)	06.2006 → 08.2013	169 A5.000 D	10	1.8 130 HGT (188.738, .718)	09.1999 → 03.2012	188 A6.000 B	45
1.3 D Multijet 4x4 (169.AXC2A)	10.2004 →	188 A8.000 D	8	1.9 DS 60 (188.031, .051, .231, .251)	09.1999 → 03.2012	188 A3.000 D	52
1.3 JTD Multijet 4x4 (169.AXG1A, 169.AXG2A)	09.2010 → 08.2013	169 A1.000 D	7	1.9 JTD	10.2001 → 03.2012	188 A7.000 D	52
1.3 JTD Multijet 4x4 (169.AXG1A, 169.AXG2A)	09.2010 → 08.2013	169 A5.000 D	10	1.9 JTD	06.2003 → 03.2012	188 B2.000 D	51
1.4 (169.AXE1B)	10.2006 →	169 A3.000 B	21	1.9 JTD 80 (188.237, .257, .337, .357)	09.1999 → 03.2012	188 A2.000 D	51
1.4 Natural Power (169.AXHIA)	09.2010 → 08.2013	350 A1.000 B	20	<b>PUNTO (199_)</b>			
<b>PANDA (312_, 319_)</b>							
1.2 (312.PXA1A)	02.2012 →	169 A4.000 B	19	1.2 (199.AXZ1A, 199.BXZ1A)	03.2012 →	169 A4.000 B	19
1.2 LPG (312.PXA1A)	06.2012 →	169 A4.000 B	19	1.3 D Multijet	03.2012 →	199 A2.000 D	7
1.3 D Multijet (312.PXL1A)	02.2012 →	199 A1.000 D	11	1.3 D Multijet	03.2012 →	199 A9.000 D	12
1.3 D Multijet (312.PXL1A)	02.2012 →	199 A9.000 D	12	1.3 D Multijet	03.2012 →	199 B1.000 D	12
				1.3 D Multijet	03.2012 →	199 B4.000 D	12
				1.3 D Multijet	12.2013 →	199 B8.000 D	13
				1.4 (199.AXB1A, 199.BXB1A, 199.AXB11)	03.2012 →	350 A1.000 B	20
				1.4 (199.AXH1A, 199.BXH1A)	03.2012 →	199 A7.000 B	22

						Pos							Pos	
1.4 Bifuel					03.2012 →	350 A1.000	B	20	<b>REGATA Weekend (138 )</b>					
1.4 Natural Power					03.2012 →	350 A1.000	B	20	1.6	09.1983 → 08.1986	138 AR.000	B	70	
1.4 T-Jet					01.2012 →	198 A1.000	B	23	1.6 (138A)	01.1987 → 08.1995	159 A3.000	B	91	
<b>PUNTO Convertible (176 )</b>									100 1.6 (RF)	09.1984 → 12.1990	149 A4.000	B	70	
60 1.2					04.1994 → 06.2000	176 A7.000	B	16	60 Diesel 1.7	05.1985 → 12.1989	149 B3.000	D	61	
60 1.2 (176AR_, 176BR_)					05.1995 → 06.2000	176 B1.000	B	16	65 Diesel 1.9	04.1984 → 07.1989	149 A1.000	D	60	
60 1.2 (176AR_, 176BR_)					05.1995 → 06.2000	176 B4.000	B	17	70 1.3	01.1984 → 07.1989	138 B2.000	B	91	
85 16V 1.2					04.1997 → 06.2000	176 B9.000	B	18	75 1.5	09.1984 → 07.1989	138 B3.048	B	91	
90 1.6					04.1994 → 04.1997	176 A9.000	B	92	75 1.5	09.1984 → 07.1989	138 C2.048	B	91	
<b>PUNTO EVO (199)</b>									80 Turbo Diesel 1.9	05.1986 → 07.1989	831 D1.000	D	60	
1.4i 16V Turbo					10.2009 → 02.2012	198 A4.000	B	23	85 1.5	06.1983 → 08.1986	138 B3.000	B	91	
<b>PUNTO EVO (199 )</b>									85 1.5	01.1984 → 04.1989	138 B3.000	B	91	
1.2					10.2009 → 02.2012	169 A4.000	B	19	<b>RITMO (138 )</b>					
1.2					10.2009 → 02.2012	199 A4.000	B	19	1.1	08.1980 → 08.1988	138 B.000	B	37	
1.3 D Multijet					07.2008 → 02.2012	199 B2.000	D	12	1.1	08.1980 → 08.1988	146 A4.000	B	37	
1.3 D Multijet					10.2009 → 02.2012	199 B1.000	D	12	1.1	10.1982 → 12.1987	138 B.000	B	37	
1.3 D Multijet					10.2009 → 02.2012	199 B4.000	D	12	1.1	10.1982 → 12.1987	138 B1.000	B	37	
1.3 D Multijet					10.2009 → 02.2012	223 A9.000	D	9	1.1	10.1982 → 12.1987	138 C1.000	B	37	
1.3 D Multijet					10.2014 →	199 A2.000	D	7	1.1	04.1985 → 12.1987	146 A4.048	B	37	
1.3 D Multijet					10.2014 →	199 A3.000	D	9	1.1 (138A)	05.1985 → 09.1987	138 C1.000	B	37	
1.3 D Multijet (199AXC1A, 199BXC1A, 199AXT1A, 199BXT1A)					10.2009 → 02.2012	199 A2.000	D	7	1.3	01.1978 → 08.1985	138 A1.000	B	91	
1.3 D Multijet (199AXC1A, 199BXC1A, 199AXT1A, 199BXT1A)					10.2009 → 02.2012	199 A9.000	D	12	1.3	01.1978 → 08.1985	149 A7.000	B	91	
1.3 D Multijet (199AXD1B, 199AXD1A, 199BXD1B, 199BXD1A,...)					10.2009 → 02.2012	199 A3.000	D	9	1.3	01.1981 → 09.1982	138 A3.000	B	91	
1.3 D Multijet (199BXC1A)					09.2010 →	199 A2.000	D	7	1.3	01.1983 → 04.1985	138 B2.000	B	91	
1.3 D Multijet (199BXC1A)					09.2010 →	199 A9.000	D	12	1.5	01.1978 → 12.1988	138 A2.000	B	91	
1.4 (199AXB1A)					10.2009 → 02.2012	350 A1.000	B	20	1.5	01.1978 → 12.1988	138 C2.048	B	91	
1.4 (199AXH1A)					07.2009 → 02.2012	199 A7.000	B	22	1.5	01.1981 → 05.1987	138 A4.000	B	91	
1.4 LPG					06.2009 → 02.2012	350 A1.000	B	20	1.5	01.1983 → 12.1987	138 B3.000	B	91	
1.4 Natural Power					10.2009 → 02.2012	350 A1.000	B	20	1.5	08.1985 → 05.1987	149 A5.000	B	91	
1.6 D Multijet					10.2009 → 02.2012	955 A3.000	D	35	1.6	05.1981 → 12.1987	138 AR.000	B	70	
<b>QUBO (225 )</b>									1.6	01.1983 → 12.1987	149 A4.000	B	70	
1.3 D Multijet (225AXE1A, 225CXE1A, 225AXH1A, 225AXL1A,...)					07.2010 →	199 B1.000	D	12	1.6	12.1985 → 12.1987	138 AR.000	B	70	
1.3 D Multijet (225CXB1A, 225AXB1A, 225CXB11, 225AXB11,...)					02.2008 →	199 A2.000	D	7	1.7 Diesel	05.1985 → 12.1987	149 B3.000	D	61	
1.3 D Multijet (225CXB1A, 225AXB1A, 225CXB11, 225AXB11,...)					02.2008 →	199 A9.000	D	12	1.9 TD	12.1985 → 12.1987	831 D1.000	D	60	
1.4 (225AXA1A, 225CXA1A)					10.2009 →	350 A1.000	B	20	75 1.3	01.1981 → 09.1982	128 A3.000	B	91	
1.4 Natural Power (225AXC1A)					10.2009 →	350 A1.000	B	20	<b>RITMO Convertible (138 )</b>					
<b>REGATA (138 )</b>									1.3	10.1979 → 09.1983	138 A1.000	B	91	
1.6 Tipo 1.6					02.1983 → 04.1995	159 A3.000	B	91	100 1.6	10.1985 → 12.1987	138 AR.000	B	70	
100 1.6					09.1983 → 08.1986	138 AR.000	B	70	50 1.3	10.1985 → 12.1987	138 B2.000	B	91	
100 Super 1.6					10.1983 → 12.1990	149 A2.000	B	70	85 1.5	01.1980 → 07.1989	138 A4.000	B	91	
100 Super 1.6					10.1983 → 12.1990	149 A4.000	B	70	85 1.5	03.1983 → 12.1986	138 B3.000	B	91	
60 Diesel 1.7					05.1985 → 03.1989	149 B3.000	D	61	<b>SEDICI (189 )</b>					
65 Diesel 1.9					04.1984 → 07.1989	149 A1.000	D	60	1.9 D Multijet	06.2006 → 10.2011	D19AA	D	52	
70 1.3					09.1983 → 07.1986	138 B2.000	B	91	1.9 D Multijet 4x4	06.2006 → 10.2011	D19AA	D	52	
70 1.3					09.1983 → 07.1989	149 A7.000	B	91	<b>SEICENTO / 600 (187 )</b>					
75 1.5					12.1983 → 07.1989	138 B3.048	B	91	0.9 (187AXA, 187AXA1A)	11.1997 → 12.2008	1170 A1.046	B	4	
75 1.5					12.1983 → 07.1989	138 C2.048	B	91	1.1 (187AXB, 187AXB1A, 187AXC1A02)	01.1998 → 01.2010	176 B2.000	B	14	
80 Turbo Diesel 1.9					05.1986 → 07.1989	831 D1.000	D	60	1.1 (187AXB, 187AXB1A, 187AXC1A02)	01.1998 → 01.2010	187 A1.000	B	15	
85 1.5					02.1984 → 08.1986	138 B3.000	B	91	<b>SIENA (178 , 172 )</b>					
85 1.5					05.1985 → 12.1987	149 A5.000	B	91	1.2	09.2001 → 12.2009	188 A5.000	B	18	
85 Super 1.5					09.1983 → 04.1985	138 B3.000	B	91	1.2 (178CXS1AAI, 178BYA1AAT, 178CYA1AAT)	09.2001 → 12.2012	188 A4.000	B	17	
									1.2 (178CXYE1AAT)	06.2001 → 10.2007	188 A5.000	B	18	
									1.3 JTD	09.2003 → 12.2009	188 A9.000	D	7	
									1.3 JTD 16V		169 A1.000	D	7	
									1.4	01.2007 → 12.2009	350 A1.000	B	20	
									1.6 (178CYC1AAT)	11.2000 → 12.2012	182 B6.000	B	42	
									1.6 16V	09.1998 → 12.2009	178 B3.000	B	94	
									1.6 16V (178CXD1AAT)	09.1998 → 12.2004	178 B3.000	B	94	
									1.7 D	01.1998 →	176 B3.000	D	60	
									1.7 D	05.1999 → 12.2009	176 B7.000	D	60	
									1.7 D	03.2002 → 12.2009	176 A3.000	D	60	
									1.7 TD	02.2006 → 12.2009	176 A3.000	D	60	
									1.9 D	01.2004 → 12.2008	223 A6.000	D	52	

F

				Pos					Pos
<b>STILO (192_)</b>					<b>TEMPRA S.W. (159_)</b>				
1.2 16V (192_XA1B)	02.2002 → 11.2006	188 A5.000	B	<b>18</b>	1.4 i.e. (159.AC)	03.1991 → 04.1993	159 A2.000	B	<b>41</b>
1.4 16V	03.2005 → 11.2006	192 B2.000	B	<b>21</b>	1.4 i.e. (159.AC, 159.AX)	10.1992 → 08.1996	159 A2.000	B	<b>41</b>
1.4 16V (192AXH1B, 192BXH1B)	10.2003 → 12.2006	843 A1.000	B	<b>21</b>	1.6	12.1990 → 04.1993	159 A3.000	B	<b>91</b>
1.6	04.2005 → 11.2006	182 B6.000	B	<b>42</b>	1.8 i.e. (159.AM)	03.1990 → 08.1996	159 A4.000	B	<b>70</b>
1.6 16V (192_XB1A)	10.2001 → 11.2006	182 B6.000	B	<b>42</b>	1.9 D (159.AG)	07.1991 → 08.1996	149 A1.000	D	<b>60</b>
1.8 16V	06.2002 → 12.2004	192 A4.000	B	<b>45</b>	1.9 D (159.AG)	07.1991 → 08.1996	160 A7.000	D	<b>60</b>
1.8 16V (192AXC1A, 192BXC1A)	10.2001 → 04.2007	192 A4.000	B	<b>45</b>	1.9 TD (159.AI, 159.BI, 159.CU, 159.AU)	07.1991 → 02.1995	160 A6.000	D	<b>62</b>
1.9 D Multijet	09.2005 → 11.2006	192 A8.000	D	<b>51</b>	1.9 TD (159.AQ)	03.1992 → 06.1993	160 B6.046	D	<b>62</b>
1.9 D Multijet	09.2005 → 11.2006	192 A9.000	D	<b>51</b>	2.0	04.1991 → 06.1993	159 A6.046	B	<b>70</b>
1.9 D Multijet	09.2005 → 11.2006	937 A5.000	D	<b>55</b>	2.0	03.1995 → 12.1996	159 A6.046	B	<b>70</b>
1.9 JTD	09.2003 → 11.2006	937 A4.000	D	<b>55</b>	2.0 i.e. (159.AP)	01.1991 → 03.1995	159 A6.046	B	<b>70</b>
1.9 JTD	01.2004 → 11.2006	192 A5.000	D	<b>54</b>	2.0 i.e. 4x4 (159.AP)	03.1992 → 03.1995	159 A6.046	B	<b>70</b>
1.9 JTD	04.2004 → 11.2006	192 B1.000	D	<b>55</b>	<b>TIPO (160_)</b>				
1.9 JTD (192_XE1A)	10.2001 → 11.2006	192 A1.000	D	<b>51</b>	1.1 (160.AA)	01.1988 → 10.1991	160 A3.000	B	<b>14</b>
1.9 JTD (192_XE1A)	10.2001 → 11.2006	937 A7.000	D	<b>51</b>	1.1i	10.1994 → 10.1995	156 C.046	B	<b>14</b>
1.9 JTD (192_XF1A)	02.2002 → 11.2006	192 A3.000	D	<b>51</b>	1.4 (160.AC)	07.1987 → 12.1989	160 A1.000	B	<b>40</b>
2.4 20V (192_XD1A, 192AXD12)	10.2001 → 04.2007	192 A2.000	B	<b>65</b>	1.4 i.e.	05.1989 → 04.1995	159 A2.000	B	<b>41</b>
Abarth 2.4i 20V	10.2001 → 09.2007	192 A2.000	B	<b>65</b>	1.6	03.1988 → 10.1992	160 A2.000	B	<b>91</b>
<b>STILO Multi Wagon (192_)</b>					1.6 (160.AE)	01.1988 → 10.1991	160 A2.000	B	<b>91</b>
1.4 16V	01.2004 → 08.2008	843 A1.000	B	<b>21</b>	1.6 (160.AZ)	12.1995 → 12.1996	159 A3.000	B	<b>91</b>
1.4 16V	03.2005 → 08.2008	192 B2.000	B	<b>21</b>	1.6 SX DGT	05.1989 → 10.1995	159 A3.000	B	<b>91</b>
1.6 16V	01.2003 → 08.2008	182 B6.000	B	<b>42</b>	1.7 D (160.AG)	01.1988 → 10.1994	149 B4.000	D	<b>61</b>
1.8 16V	01.2003 → 08.2008	192 A4.000	B	<b>45</b>	1.7 D (160.AG)	01.1988 → 10.1995	149 B4.000	D	<b>61</b>
1.9 D Multijet	09.2005 → 08.2008	192 A8.000	D	<b>51</b>	1.8 i.e.	10.1990 → 06.1993	159 A4.000	B	<b>70</b>
1.9 D Multijet	09.2005 → 08.2008	192 A9.000	D	<b>51</b>	1.8 i.e. (160.EQ, 160.AM)	10.1994 → 10.1995	159 A4.000	B	<b>70</b>
1.9 D Multijet (192DXT1B)	09.2005 → 08.2008	937 A5.000	D	<b>55</b>	1.8 i.e. 16V Sport	11.1989 → 06.1992	160 A5.000	B	<b>72</b>
1.9 JTD	01.2003 → 08.2008	192 A1.000	D	<b>51</b>	1.9 D	07.1991 → 08.1995	149 A1.000	D	<b>60</b>
1.9 JTD	01.2003 → 08.2008	192 A3.000	D	<b>51</b>	1.9 D	07.1991 → 08.1995	160 A7.000	D	<b>60</b>
1.9 JTD	01.2003 → 08.2008	937 A7.000	D	<b>51</b>	1.9 TD (160.AW)	03.1992 → 06.1993	160 B6.046	D	<b>62</b>
1.9 JTD	09.2003 → 08.2008	937 A4.000	D	<b>55</b>	1.9 TD (160.EL, 160.GL, 160.AQ, 160.EI, 160.AR)	09.1990 → 04.1995	160 A6.000	D	<b>62</b>
1.9 JTD	01.2004 → 08.2008	192 A5.000	D	<b>54</b>	1.9 TD (160.EL, 160.GL, 160.AQ, 160.EI, 160.AR)	09.1990 → 04.1995	160 A6.046	D	<b>62</b>
1.9 JTD	04.2004 → 08.2008	192 B1.000	D	<b>55</b>	1.9 TD (160.AR)	04.1990 → 10.1992	160 A6.046	D	<b>62</b>
<b>STRADA (178E)</b>					2.0	10.1990 → 10.1992	159 A6.046	B	<b>70</b>
1.1	02.1983 → 1985	138 B.000	B	<b>37</b>	2.0 i.e. (160.AT, 160.AJ)	03.1990 → 04.1995	159 A6.046	B	<b>70</b>
1.1	02.1983 → 12.1987	138 C1.000	B	<b>37</b>	2.0 i.e. 16V Sport (160.EF)	03.1993 → 04.1995	836 A3.000	B	<b>72</b>
1.7 D	05.1985 → 12.1987	149 B3.000	D	<b>61</b>	<b>TIPO Estate (356_)</b>				
<b>STRADA Pickup (178_)</b>					1.4 (356WXA1B)	03.2016 →	843 A1.000	B	<b>21</b>
1.2	04.2003 →	188 A4.000	B	<b>17</b>	<b>TIPO Hatchback (356_)</b>				
1.3 D Multijet	05.2006 →	223 A9.000	D	<b>9</b>	1.4 (356HXA1B)	03.2016 →	843 A1.000	B	<b>21</b>
1.3 D Multijet (278AYR1A)	03.2010 →	199 B1.000	D	<b>12</b>	<b>TIPO Saloon (356_)</b>				
1.3 D Multijet (278AYR1A)	10.2010 →	199 B1.000	D	<b>12</b>	1.3 D (356SXB1A, 356SXH1A, 356SXD1A)	10.2015 →	199 B1.000	D	<b>12</b>
1.6 16V	02.1998 → 02.2003	178 D2.011	B	<b>95</b>	1.4 (356SXA1B)	10.2015 →	843 A1.000	B	<b>21</b>
1.6 Trekking	11.2005 →	178 D2.011	B	<b>95</b>	<b>ULYSSE (179_)</b>				
1.7 TD	06.1999 → 12.2006	176 A3.000	D	<b>60</b>	2.0 (179BXA11, 179BXA1A)	08.2002 → 06.2011	RFN (EW10J4)	B	<b>74</b>
1.7 TD	02.2002 → 01.2010	176 A3.000	D	<b>60</b>	2.0 D Multijet	05.2006 → 06.2011	RHK	D	<b>77</b>
1.9 D	12.2000 →	223 A6.000	D	<b>52</b>	2.0 D Multijet	05.2006 → 06.2011	RHR	D	<b>81</b>
1.9 JTD	04.2003 →	188 A2.000	D	<b>51</b>	2.0 JTD	08.2002 → 08.2006	RHW	D	<b>76</b>
<b>TEMPRA (159_)</b>					2.0 JTD	05.2003 → 08.2006	(DW10ATED4)	D	<b>77</b>
1.4 i.e. (159.AA)	03.1991 → 04.1993	159 A2.000	B	<b>41</b>	2.2 D Multijet	03.2008 → 06.2011	4HT (DW12BTED4)	D	<b>82</b>
1.4 i.e. (159.AC, 159.AX)	04.1990 → 08.1996	159 A2.000	B	<b>41</b>	2.2 JTD	08.2002 → 08.2006	4HW (DW12ATED4)	D	<b>80</b>
1.6 (159.AD)	03.1990 → 04.1994	159 A3.000	B	<b>91</b>	2.2 JTD	03.2008 → 06.2011	4HP	D	<b>83</b>
1.8 i.e. (159.AN)	03.1990 → 08.1996	159 A4.000	B	<b>70</b>	2.2 JTD	03.2008 → 06.2011	4HR	D	<b>83</b>
1.9 D (159.AG)	07.1991 → 08.1996	149 A1.000	D	<b>60</b>	3.0	08.2002 → 06.2011	XFW	B	<b>96</b>
1.9 D (159.AG)	07.1991 → 08.1996	160 A7.000	D	<b>60</b>	<b>ULYSSE (220_)</b>				
1.9 TD (159.AQ)	07.1992 → 08.1996	160 B6.046	D	<b>62</b>	1.8 (220.BB5)	05.1997 → 08.2002	LFW (XU7JP)	B	<b>64</b>
1.9 TD (159.CU, 159.AU, 159.AI, 159.BI)	05.1990 → 08.1996	160 A6.000	D	<b>62</b>	1.9 TD	05.1997 → 12.1999	DHX (XUD9TF/L)	D	<b>66</b>
2.0	04.1990 → 06.1993	159 A6.046	B	<b>70</b>	1.9 TD (220AH5)	02.1995 → 08.2002	DHX (XUD9TF/L)	D	<b>66</b>
2.0	05.1994 → 12.1998	159 A6.046	B	<b>70</b>	2.0 16V	07.1998 → 09.2000	RFV	B	<b>87</b>
2.0	05.1994 → 12.1998	159 A6.046	B	<b>70</b>					
2.0 16V	09.1993 → 12.1998	154 E1.000	B	<b>72</b>					
2.0 16V	01.1994 → 06.1998	154 E1.000	B	<b>72</b>					
2.0 i.e. (159.AP)	10.1990 → 09.1996	159 A6.046	B	<b>70</b>					

				Pos					Pos
2.0 16V (220AQ5)	09.2000 → 08.2002	RFN (EW10J4)	B	74	1.3 JTD 16V	05.2004 → 12.2006	188 A9.000	D	7
2.0 JTD	10.1999 → 08.2002	RHZ	D	79	1.3 JTD 16V Multijet	08.2006 →	223 A9.000	D	9
2.0 JTD 16V	05.1999 → 08.2002	RHW (DW10ATED4)	D	76	1.4	10.2005 →	350 A1.000	B	20
2.0 Turbo (220.AD5)	06.1994 → 08.2002	RGX (XU10J2CTE)	B	86	1.6 16V	11.2001 → 08.2003	182 B6.000	B	42
<b>UNO</b>					1.6 16V (223ZXD1A)	10.2001 →	182 B6.000	B	42
1.5	01.1983 → 04.1985	138 B3.048	B	91	1.6 Natural Power	09.2002 →	182 B6.000	B	42
<b>UNO (146_)</b>					1.6 Natural Power (223WXD1A)	02.2004 → 07.2009	182 B6.000	B	42
0.9	02.1984 → 08.1989	100 GL.000	B	1	1.9 D (223ZXB1A)	03.2001 →	223 A6.000	D	52
0.9i	01.2000 →	1170 A1.046	B	4	1.9 JTD	07.2003 →	223 A7.000	D	53
1.0 (146E)	06.1989 → 02.1992	156 A2.000	B	14	1.9 JTD	07.2003 →	223 B1.000	D	53
1.0 Mille Fire MPI	06.2001 → 12.2003	156 A2.246	B	14	1.9 JTD (223ZXE1A)	10.2001 →	182 B9.000	D	51
1.0 iE	05.1998 → 08.2000	156 A2.246	B	14	1.9 JTD Multijet	12.2006 →	186 A9.000	D	51
1.1	04.1986 → 06.2006	160 A3.000	B	14	<b>DOBLO Bus (263_)</b>				
1.1	10.1988 → 06.2006	146 A4.048	B	37	1.3 D Multijet	02.2010 →	199 A3.000	D	9
1.1	10.1988 → 06.2006	160 A3.000	B	14	(263AXC1A)				
1.1 IE	08.1992 → 12.1996	160 A3.000	B	14	1.3 D Multijet	02.2010 →	263 A2.000	D	11
1.2	08.2000 → 08.2009	188 A4.000	B	17	(263AXC1A)				
1.7 D	11.1994 → 08.2000	146 B2.000	D	60	1.4 (263AXA1A)	02.2010 →	843 A1.000	B	21
45 0.9	03.1983 → 09.1992	146 A.000	B	2	1.4 (263AXG1B, 263AXG1A)	10.2011 →	198 A4.000	B	23
45 0.9	03.1983 → 09.1992	146 A1.000	B	3	1.4 Natural Power	02.2010 →	198 A4.000	B	23
45 0.9	02.1984 → 12.1988	146 A.000	B	2	(263AXG1B)				
45 1.0 (146A.ED)	06.1986 → 12.1993	156 A2.048	B	15	1.6 D Multijet	01.2010 →	198 A3.000	D	33
45 1.0 (146A.ED)	06.1986 → 12.1993	156 A2.100	B	15	(263AXD1B)				
45 i.e. 1.0 (146E, 146A)	10.1984 → 10.1995	156 A2.000	B	14	1.6 D Multijet	03.2016 →	263 A3.000	D	36
45 i.e. 1.0 (146E, 146A)	10.1984 → 10.1995	156 A2.246	B	14	(263AXE1B)				
50 1.1	01.1990 → 12.1993	156 C.046	B	14	2.0 D Multijet	01.2010 →	263 A1.000	D	69
55 1.1	01.1983 → 08.1989	138 B.000	B	37	(263AXF1B)				
60 1.1	04.1989 → 12.1992	160 A3.000	B	14	<b>DOBLO Cargo (263_)</b>				
60 1.1 (146A.EG)	05.1985 → 08.1989	146 A4.048	B	37	1.3 D Multijet	02.2010 →	199 A3.000	D	9
60 Diesel 1.7	07.1986 → 08.1989	149 B3.000	D	61	1.3 D Multijet	02.2010 →	263 A2.000	D	11
60 Diesel 1.7 (146E)	09.1989 → 12.1993	146 B2.000	D	60	1.4	02.2010 →	843 A1.000	B	21
70 1.3	01.1983 → 04.1985	138 B2.000	B	91	1.4	10.2011 →	198 A4.000	B	23
70 1.3	05.1985 → 08.1989	149 A7.000	B	91	1.4 Natural Power	06.2010 →	198 A4.000	B	23
70 i.e. 1.4	09.1989 → 12.1993	146 C1.000	B	41	1.6 D Multijet	02.2010 →	198 A3.000	D	33
75 i.e. 1.5	10.1985 → 12.1993	138 C2.048	B	91	1.6 D Multijet	02.2010 →	263 A3.000	D	36
<b>UNO MONDO</b>					2.0 D Multijet	02.2010 →	263 A1.000	D	69
0.9i	10.1999 →	1170 A1.046	B	4	<b>DOBLO Platform/Chassis (263_)</b>				
1.0i	01.1996 →	156 A2.246	B	14	1.3 D Multijet	02.2010 →	199 A3.000	D	9
1.1	01.1998 →	160 A3.000	B	14	1.3 D Multijet	02.2010 →	263 A2.000	D	11
1.7 D	01.1996 →	146 B2.000	D	60	1.4	04.2010 →	843 A1.000	B	21
<b>X 1/9 (128_)</b>					1.4	10.2011 →	198 A4.000	B	23
1.3	05.1973 → 12.1979	128 AS.000	B	85	1.4 Natural Power	06.2010 →	198 A4.000	B	23
1.3	09.1973 → 12.1974	128 AS.000	B	85	1.6 D Multijet	02.2010 →	198 A3.000	D	33
1.3	09.1974 → 12.1978	128 AS.000	B	85	1.6 D Multijet	02.2011 →	263 A3.000	D	36
1.3	10.1975 → 06.1978	128 AS.000	B	85	2.0 D Multijet	02.2010 →	263 A1.000	D	69
1.5 (128AS1_)	11.1978 → 12.1989	138 A4.000	B	91	<b>DUCATO Bus (230_)</b>				
					1.9 D	04.1998 → 04.2002	DJY	D	68
<b>242 Van (242_)</b>					1.9 D Combinato	06.1995 → 04.2002	230 A2.000	D	60
2.5 D	08.1980 → 07.1982	B 25.637	D	106	1.9 TD	04.1998 → 04.2002	DHX (XUD9TF/L)	D	66
<b>900 T/E Panorama (200_)</b>					2.5 D	03.1994 → 04.2002	8140.67	D	104
0.9	01.1978 → 01.1986	100 GF 000	B	1	2.5 D Combinato	08.1994 → 04.2002	8140.67	D	104
<b>900 T/E Pulmino (200_)</b>					2.5 TD 4x4	06.1994 → 09.2001	8140.47	D	112
0.9	01.1978 → 01.1986	100 GF 000	B	1	2.5 TD 4x4	11.1994 → 04.1998	8140.47	D	112
<b>BRAVO Van (198_)</b>					2.5 TDI 4x4	04.1997 → 04.2002	8140.47	D	112
1.6 JTD Multijet (198AXH1B)	03.2008 → 12.2014	198 A3.000	D	33	2.5 TDI Panorama/ Combinato	03.1994 → 04.2002	8140.47	D	112
<b>CAMPAGNOLA (110_)</b>					2.5 TDI Panorama/ Combinato	07.1994 → 04.2002	8140.47R	D	112
2.5 D	06.1979 → 10.1986	8142.61	D	105	2.8 D	02.1998 → 04.2002	8140.63	D	115
<b>CINQUECENTO VAN (170_)</b>					2.8 JTD	11.2000 → 04.2002	8140.43S	D	115
0.9 iE (170CF)	07.1991 → 02.1998	1170 A1.046	B	4	2.8 JTD 4x4	11.2000 → 04.2002	8140.43S	D	115
1.1 iE (170AH)	10.1994 → 02.1998	176 B2.000	B	14	2.8 TDI	10.1997 → 04.2002	8140.43	D	115
<b>CROMA Estate Van (194_)</b>					2.8 TDI 4x4	07.1999 → 04.2002	8140.43	D	115
1.9 MJTD (194AXB1B)	04.2006 → 12.2011	939 A1.000	D	56	<b>DUCATO Bus (244_)</b>				
<b>DOBLO Box Body/MPV (223_)</b>					2.3 JTD	04.2002 →	F1AE0481C	D	99
1.2 (223ZXA1A)	03.2001 → 01.2004	223 A5.000	B	17	2.8 JTD	04.2002 →	8140.43S	D	115
1.3 D Multijet	10.2005 → 01.2010	199 A2.000	D	7	2.8 JTD	04.2004 → 07.2006	8140.43N	D	115
1.3 JTD 16V	05.2004 → 12.2006	188 A8.000	D	8	2.8 JTD 4x4	07.2002 →	8140.43S	D	115

F



			Pos				Pos				
2.8 TD	11.2003 → 07.2006	8140.43	D	115	1.9 D	06.1990 → 05.1994	149 B1.000	D	61		
2.8 TD 4x4	11.2003 → 07.2006	8140.43	D	115	1.9 TD	03.1989 → 03.1994	280 A1.000	D	61		
<b>DUCATO Bus (250_)</b>				<b>DUCATO Van (230_)</b>							
120 Multijet 2,3 D	07.2006 →	F1AE0481D	D	100	1.9 D	03.1994 → 04.2002	230 A2.000	D	60		
130 Multijet 2,3 D	06.2011 →	F1AE0481N	D	100	1.9 D	04.1998 → 04.2002	DJY	D	68		
130 Multijet 2,3 D	06.2011 →	F1AE3481D	D	100	1.9 TD	04.1998 → 04.2002	DHX (XUD9TF/L)	D	66		
130 Multijet 2,3 D 4x4	06.2011 →	F1AE0481N	D	100	2.5 D	03.1994 → 04.2002	8140.67	D	104		
130 Multijet 2,3 D 4x4	06.2011 →	F1AE3481D	D	100	2.5 D 4x4	03.1994 → 04.2002	8140.67	D	104		
140 Natural Power	04.2009 →	F1CE0441A	BG	120	2.5 TD	06.1994 → 08.1998	8140.47	D	112		
150 Multijet 3,0 D	04.2010 →	F1CE3481N	D	123	2.5 TD 4x4	11.1994 → 04.1998	8140.47	D	112		
160 Multijet 3,0 D	07.2006 →	F1CE0481D	D	121	2.5 TD 4x4	11.1994 → 04.1998	8140.47	D	112		
160 Multijet 3,0 D	07.2006 →	F1CE3481M	D	122	2.5 TDI	03.1994 → 04.2002	8140.47	D	112		
160 Multijet 3,0 D	10.2006 →	F1CE0481D	D	121	2.5 TDI	03.1994 → 04.2002	8140.47R	D	112		
160 Multijet 3,0 D 4x4	07.2006 →	F1CE0481D	D	121	2.5 TDI 4x4	05.1998 → 04.2002	8140.47	D	112		
160 Multijet 3,0 D 4x4	07.2006 →	F1CE3481M	D	122	2.8 D	05.1998 → 04.2002	8140.63	D	115		
180 Multijet 3,0 D	06.2011 →	F1CE3481E	D	123	2.8 D 4x4	08.1998 → 04.2002	8140.63	D	115		
<b>DUCATO II (244)</b>				<b>DUCATO Van (244_)</b>							
2.8 TD	10.2002 → 06.2006	8140.43.3700	D	115	2.8 JTD	11.2000 → 04.2002	8140.43S	D	115		
<b>DUCATO Panorama (280_)</b>				<b>DUCATO Van (244_)</b>							
1.9 D	02.1987 → 08.1990	149 B1.000	D	61	2.8 JTD 4x4	11.2000 → 04.2002	8140.43S	D	115		
1.9 TD	03.1989 → 08.1990	280 A1.000	D	61	2.8 TD 4x4	05.1998 → 09.2001	8140.43	D	115		
2.4 D	07.1982 → 12.1985	8144.61	D	104	2.8 TDI	10.1997 → 04.2002	8140.43	D	115		
2.5 TD	01.1987 → 08.1990	8144.21	D	109	2.8 TDI 4x4	06.1999 → 04.2002	8140.43	D	115		
2.5 TD	01.1987 → 08.1990	8144.21.220	D	109	<b>DUCATO Van (244_)</b>						
2.5 TD 4x4	01.1986 → 08.1990	8144.21	D	109	2.3 JTD	04.2002 →	F1AE0481C	D	99		
<b>DUCATO Panorama (290_)</b>				<b>DUCATO Van (244_)</b>							
1.9 D	07.1990 → 03.1994	149 B1.000	D	61	2.8 JTD	04.2002 →	8140.43S	D	115		
1.9 TD	07.1990 → 03.1994	280 A1.000	D	61	2.8 JTD	06.2005 → 08.2009	8140.43S	D	115		
<b>DUCATO Platform/Chassis (230_)</b>				<b>DUCATO Van (244_)</b>							
1.9 D	03.1994 → 04.2002	230 A2.000	D	60	2.8 JTD 4x4	07.2002 →	8140.43S	D	115		
1.9 D	04.1998 → 04.2002	DJY	D	68	2.8 JTD Power	05.2004 →	8140.43N	D	115		
1.9 TD	04.1998 → 04.2002	DHX (XUD9TF/L)	D	66	2.8 TD	04.2002 → 07.2006	8140.43	D	115		
2.5 D	03.1994 → 04.2002	8140.67	D	104	2.8 TD 4x4	11.2003 → 07.2006	8140.43	D	115		
2.5 D 4x4	03.1994 → 04.2002	8140.67	D	104	<b>DUCATO Van (250_)</b>						
2.5 TD	06.1994 → 04.1998	8140.47	D	112	120 Multijet 2,3 D	07.2006 →	F1AE0481D	D	100		
2.5 TD	06.1994 → 08.1998	8140.47	D	112	120 Multijet 2,3 D 4x4	03.2010 →	F1AE0481D	D	100		
2.5 TD 4x4	11.1994 → 04.1998	8140.47	D	112	130 Multijet 2,3 D	06.2011 →	F1AE0481N	D	100		
2.5 TD 4x4	11.1994 → 04.1998	8140.47	D	112	130 Multijet 2,3 D	06.2011 →	F1AE3481D	D	100		
2.5 TDI	03.1994 → 04.2002	8140.47R	D	112	130 Multijet 2,3 D 4x4	06.2011 →	F1AE0481N	D	100		
2.5 TDI 4x4	06.1998 → 04.2002	8140.47	D	112	130 Multijet 2,3 D 4x4	06.2011 →	F1AE3481D	D	100		
2.8 D	02.1998 → 04.2002	8140.63	D	115	140 Natural Power	04.2009 →	F1CE0441A	BG	120		
2.8 JTD	11.2000 → 04.2002	8140.43S	D	115	150 Multijet 3,0 D	04.2010 →	F1CE3481N	D	123		
2.8 JTD 4x4	10.2001 → 04.2002	8140.43S	D	115	160 Multijet 3,0 D	07.2006 → 12.2011	F1CE3481M	D	122		
2.8 TD 4x4	05.1998 → 11.2001	8140.63	D	115	160 Multijet 3,0 D	07.2006 →	F1CE0481D	D	121		
2.8 TDI	12.1998 → 04.2002	8140.43	D	115	160 Multijet 3,0 D 4x4	07.2006 →	F1CE0481D	D	121		
2.8 iDTD 4x4	05.1998 → 09.2001	8140.43	D	115	160 Multijet 3,0 D 4x4	07.2006 →	F1CE3481M	D	122		
<b>DUCATO Platform/Chassis (244_)</b>				<b>DUCATO Van (280_)</b>							
2.3 JTD	04.2002 → 07.2006	F1AE0481C	D	99	1.9 D	01.1988 → 08.1990	149 B1.000	D	61		
2.8 JTD	04.2002 → 07.2006	8140.43S	D	115	1.9 TD	03.1989 → 08.1990	280 A1.000	D	61		
2.8 JTD	11.2003 → 07.2006	8140.43	D	115	2.4 D	01.1982 → 08.1990	8144.61	D	104		
2.8 JTD 4x4	10.2002 → 07.2006	8140.43S	D	115	2.5 D	09.1986 → 05.1990	8140.61	D	104		
2.8 JTD 4x4	11.2003 → 07.2006	8140.43	D	115	2.5 D 4x4	09.1986 → 10.1987	8140.61	D	104		
2.8 JTD Power	05.2004 → 07.2006	8140.43N	D	115	2.5 D 4x4	09.1986 → 05.1990	8140.61	D	104		
<b>DUCATO Platform/Chassis (250_)</b>				<b>DUCATO Van (280_)</b>							
120 Multijet 2,3 D	07.2006 →	F1AE0481D	D	100	1.9 D	07.1990 → 03.1994	149 B1.000	D	61		
120 Multijet 2,3 D 4x4	03.2010 →	F1AE0481D	D	100	1.9 TD	03.1989 → 03.1994	280 A1.000	D	61		
130 Multijet 2,3 D	07.2006 →	F1AE0481N	D	100	<b>FIORINO (127_)</b>						
130 Multijet 2,3 D	07.2006 →	F1AE3481D	D	100	900	10.1977 → 10.1986	100 GL.000	B	1		
140 Natural Power	04.2009 →	F1CE0441A	BG	120	<b>FIORINO (147_)</b>						
150 Multijet 3,0 D	04.2010 →	F1CE3481N	D	123	1.0	12.1986 → 04.1988	156 A.000	B	28		
160 Multijet 3,0 D	07.2006 → 12.2011	F1CE3481M	D	122	<b>FIORINO Box Body/MPV (146_)</b>						
160 Multijet 3,0 D	07.2006 →	F1CE0481D	D	121	1.0 iE	11.1992 → 04.1996	156 A2.246	B	14		
180 Multijet 3,0 D	06.2011 →	F1CE3481E	D	123	1.7 D	01.1988 → 10.1999	146 B2.000	D	60		
<b>DUCATO Platform/Chassis (280_)</b>				<b>FIORINO Box Body/MPV (225_)</b>							
1.9 D	01.1988 → 08.1990	149 B1.000	D	61	1.7 TD	01.1997 → 05.2000	146 D7.000	D	60		
1.9 TD	03.1989 → 08.1990	280 A1.000	D	61	1.7 TD	01.2004 → 08.2006	176 A3.000	D	60		
2.5 TD	01.1986 → 08.1990	8144.21	D	109	60 1.7 D	05.1988 → 12.1991	149 B3.000	D	61		
2.5 TD 4x4	01.1986 → 08.1990	8144.21	D	109	60 1.7 D	05.1988 → 10.1996	146 B2.000	D	60		
<b>DUCATO Platform/Chassis (290_)</b>				<b>FIORINO Box Body/MPV (225_)</b>							
				65 1.7 TD				01.1997 → 05.2001	146 D7.000	D	60



			Pos				Pos		
1.3 D Multijet (225BXD1A, 225BxB1A, 225BxB11)	11.2007 →	199 A2.000	D	7	1.3 D Multijet 4x4 (312CXL2A)	06.2012 →	199 A9.000	D	12
1.3 D Multijet (225BXD1A, 225BxB1A, 225BxB11)	11.2007 →	199 A9.000	D	12	<b>PENNY Estate Van (257_)</b>				
1.3 D Multijet (225BXE1A)	07.2009 →	199 B1.000	D	12	1.7 D	01.1986 → 12.1990	149 B3.000	D	61
1.4 (225AXA1A, 225BXA1A)	10.2009 →	350 A1.000	B	20	<b>PUNTO EVO Hatchback Van (199_)</b>				
1.4 Natural Power (225AXC1A, 225BXC1A)	06.2008 →	350 A1.000	B	20	1.3 D Multijet (199.AXT1A, 199.AXC1A)	03.2009 → 02.2012	199 A2.000	D	7
1.4 Natural Power (225BXC1A, 225AXC1A)	06.2008 →	350 A1.000	B	20	1.3 D Multijet (199.AXT1A, 199.AXC1A)	03.2009 → 02.2012	199 A9.000	D	12
<b>GRANDE PUNTO Van (199_)</b>					1.3 D Multijet (199.CXD1B, 199.CXD1A)	03.2009 → 02.2012	199 B1.000	D	12
1.3 JTD Multijet (199CXC1A)	02.2006 → 06.2013	199 A2.000	D	7	1.3 D Multijet (199.AXU1A)	03.2009 → 02.2012	199 A3.000	D	9
1.3 JTD Multijet (199CXD1B)	02.2006 → 08.2010	199 A3.000	D	9	1.4 (199.AXB1A)	03.2009 → 02.2012	350 A1.000	B	20
1.4 (199CXB1A, 199DXB1A)	02.2006 → 06.2013	350 A1.000	B	20	<b>PUNTO Hatchback Van (188_)</b>				
1.4 LPG (199CXB1A, 199DXB1A)	03.2009 → 12.2012	350 A1.000	B	20	1.2 60	02.2000 → 10.2009	188 A4.000	B	17
1.4 Natural Power (199BxB1A)	03.2009 → 12.2012	350 A1.000	B	20	1.2 Natural Power (188CXA1A)	01.2003 → 12.2010	188 A4.000	B	17
<b>IDEA Van (350_)</b>					1.3 JTD	06.2003 → 10.2005	188 A9.000	D	7
1.4 (350BXA1A)	10.2004 → 12.2012	843 A1.000	B	21	1.9 D 60	02.2000 → 10.2009	188 A3.000	D	52
JTD Multijet (350BxB1A)	10.2004 → 12.2011	188 A9.000	D	7	1.9 JTD	02.2000 → 10.2009	188 A7.000	D	52
JTD Multijet (350BxG1A)	04.2005 → 12.2010	199 A3.000	D	9	<b>PUNTO Hatchback Van (199_)</b>				
MJTD (350BXD1A)	10.2004 → 12.2010	188 B2.000	D	51	1.3 D Multijet	04.2008 →	199 A2.000	D	7
<b>MULTIPLA VAN (186_)</b>					1.3 D Multijet	04.2008 →	199 A9.000	D	12
1.6 (186AXC1A, 186BMC1A, 186BXC1A)	09.2000 → 06.2010	182 B6.000	B	42	1.3 D Multijet	03.2009 →	199 B1.000	D	12
1.9 JTD	09.2000 → 03.2002	186 A6.000	D	51	1.3 D Multijet	03.2012 →	199 B4.000	D	12
1.9 JTD	05.2004 → 06.2010	186 A8.000	D	52	1.4 (199BxB1A, 199AXL1A, 199AXB1A)	03.2012 →	350 A1.000	B	20
1.9 JTD (186AXB1A)	04.1999 → 08.2000	182 B4.000	D	52	1.4 LPG (199AXB1A, 199BxB1A, 199AXL1A)	03.2012 → 02.2012	350 A1.000	B	20
1.9 JTD (186AXG1A, 186BxG1A)	04.2002 → 06.2010	186 A9.000	D	51	1.4 Natural Power (199AXB1A, 199AXL1A)	03.2009 →	350 A1.000	B	20
Bipower	10.2001 → 06.2010	182 B6.000	B	42	<b>PUNTO Van (176_)</b>				
<b>PANDA Hatchback Van (141_)</b>					1.1	04.1996 → 02.2000	176 B2.000	B	14
1.1	05.1991 → 03.1995	156 C.046	B	14	1.7 D	04.1996 → 02.2000	176 B3.000	D	60
1.1	09.2000 → 02.2004	187 A1.000	B	15	1.7 TD	04.1996 → 02.2000	176 A5.000	D	63
1.1 4x4	09.2000 → 02.2004	187 A1.000	B	15	1.7 TD	09.1996 → 09.1999	176 B7.000	D	60
1000	01.1986 → 02.1992	156 A2.100	B	15	<b>SCUDO Bus (220_)</b>				
1000	01.1986 → 02.1992	156 A3.100	B	14	1.9 D	02.1996 → 04.1998	D9B	D	67
1000 i.e	08.1992 → 02.2004	156 A2.246	B	14	1.9 D	04.1998 → 12.2006	WJZ (DW8)	D	59
750	01.1986 → 07.1992	141 B.000	B	1	1.9 TD	02.1996 → 12.2006	D8B	D	66
<b>PANDA Hatchback Van (169_)</b>					1.9 TD Eco	02.1996 → 12.2006	DHX (XUD9TF/L)	D	66
1.1 (169CXA1A)	09.2004 →	187 A1.000	B	15	2.0 16V	06.2000 → 12.2006	RFN (EW10J4)	B	74
1.2	09.2004 →	188 A4.000	B	17	2.0 JTD	12.1999 → 12.2006	RHZ	D	79
1.2	09.2010 →	169 A4.000	B	19	2.0 JTD	01.2004 → 12.2006	RHX	D	78
1.2 4x4	09.2004 →	188 A4.000	B	17	2.0 JTD 16V	05.1999 → 12.2006	RHW	D	76
1.2 4x4	09.2010 →	169 A4.000	B	19	<b>SCUDO Bus (270_ , 272_)</b>				
1.2 Bipower (169CXB1A)	09.2004 → 12.2011	188 A4.000	B	17	1.6 D Multijet	01.2007 →	9HU	D	25
1.2 LPG	04.2009 →	188 A4.000	B	17	1.6 D Multijet	02.2011 →	9HM (DV6UC)	D	26
1.2 LPG	09.2010 →	169 A4.000	B	19	2.0 D Multijet	01.2007 →	RHK	D	77
1.2 Natural Power	01.2007 → 11.2009	188 A4.000	B	17	2.0 D Multijet	01.2007 →	RHR	D	81
1.3 D Multijet	03.2004 →	188 A8.000	D	8	2.0 D Multijet	07.2010 →	RHH	D	84
1.3 D Multijet	01.2006 →	169 A1.000	D	7	2.0 D Multijet 4x4	01.2007 →	RHK	D	77
1.3 D Multijet 4x4	10.2004 → 12.2006	188 A8.000	D	8	2.0 D Multijet 4x4	01.2007 →	RHR	D	81
1.3 D Multijet 4x4	01.2006 →	169 A1.000	D	7	<b>SCUDO Platform/Chassis (220_)</b>				
1.4 Natural Power	10.2009 →	350 A1.000	B	20	1.9 D	04.1998 → 12.2006	WJY (DW8)	D	58
<b>PANDA VAN (312_ , 519_)</b>					1.9 TD	09.1996 → 12.2006	D8B	D	66
1.2 (312CXA1A, 312DXA1A)	02.2012 →	169 A4.000	B	19	1.9 TD	09.1996 → 12.2006	DHX (XUD9TF/L)	D	66
1.2 LPG (312CXA1A)	06.2012 →	169 A4.000	B	19	2.0 JTD	10.1999 → 12.2006	RHX	D	78
1.3 D Multijet (312CXL1A, 312DXL1A)	02.2012 →	199 A9.000	D	12	2.0 JTD	12.2002 → 12.2006	RHZ	D	79
					2.0 JTD 16V	05.1999 → 12.2006	RHK	D	75
					<b>SCUDO Platform/Chassis (270_ , 272_)</b>				
					2.0 JTD 16V	05.1999 → 12.2006	RHW	D	76
					<b>SCUDO Platform/Chassis (270_ , 272_)</b>				
					1.6 D Multijet	01.2007 →	9HU	D	25
					2.0 D Multijet	01.2007 →	DW10BTED4	D	77

F

				Pos					Pos		
2.0 D Multijet	01.2007 →	RHK	D	77		Series 100	100E	01.1973 → 12.1976	8060.02.000	D	127
2.0 D Multijet	01.2007 →	RHR	D	81			100NC	01.1973 → 12.1975	8060.02.000	D	127
2.0 D Multijet	07.2010 →	RHH	D	84			Series 110				
SCUDO Van (220_)					Series 110						
1.9 D	02.1996 → 12.2006	D9B	D	67	110-17	1986 → 1991	8060.25.000	D	136		
1.9 D	04.1998 → 12.2006	WJY (DW8B)	D	59	110NC	01.1973 → 12.1983	8060.02.000	D	127		
1.9 D	04.1998 → 12.2006	WJZ (DW8)	D	59	110NC	05.1978 → 12.1981	8360.04.200	D	139		
1.9 TD	02.1996 → 12.2006	DHX (XUD9TF/L)	D	66	110NC	05.1978 → 12.1981	8360.04.300	D	139		
1.9 TD	02.1998 → 12.2006	D8B	D	66	115.14.1	11.1985 → 12.1991	8060.05.200	D	136		
2.0	05.2000 → 12.2006	RFN (EW10J4)	B	74	Series 140						
2.0 JTD	10.1999 → 12.2006	RHX	D	78	140	01.1979 →	8360.04.200	D	139		
2.0 JTD	12.2002 → 12.2006	RHZ	D	79	140	01.1979 →	8360.05.300	D	139		
2.0 JTD 16V	05.1999 → 12.2006	RHK	D	75	Series 300						
		(DW10UTED4)			300	01.1966 → 1971	8025.01	D	119		
2.0 JTD 16V	05.1999 → 12.2006	RHM	D	77	300	1972 →	8025.02.001	D	127		
		(DW10ATED4)			300	1972 →	8065.02.217	D	127		
2.0 JTD 16V	05.1999 → 12.2006	RHW	D	76	300	09.1972 → 02.1982	8060.02.000	D	127		
		(DW10ATED4)			300	10.1987 → 12.1995	8210.22.559	D	145		
SCUDO Van (270_ , 272_)					314	01.1966 → 1971	806.000	D	119		
1.6 D Multijet	01.2007 →	9HU	D	25	314	01.1966 → 1971	8060.01	D	119		
1.6 D Multijet	02.2011 →	9HM (DV6UC)	D	26	314	1972 →	8065.02.217	D	127		
2.0 D Multijet	01.2007 →	RHK	D	77	314	09.1972 → 02.1982	8060.02.000	D	127		
2.0 D Multijet	01.2007 →	RHR	D	81	314	10.1987 → 12.1995	8210.22.559	D	145		
2.0 D Multijet	07.2010 →	RHH	D	84	314	01.1966 → 1971	806.000	D	119		
2.0 D Multijet 4x4	01.2007 →	RHK	D	77	314	1972 →	8065.02.217	D	127		
2.0 D Multijet 4x4	01.2007 →	RHR	D	81	314	09.1972 → 02.1982	8060.02.000	D	127		
2.0 D Multijet 4x4	01.2007 →	RHR	D	77	315.8.17	1985 → 1987	8060.24.001	D	134		
SEICENTO / 600 Hatchback Van (287_)					316.8.18	06.1991 → 11.2000	8060.45B.5160	D	136		
0.9 (187AXA)	01.1998 → 01.2010	1170 A1.046	B	4	370S30	01.1958 → 12.1971	8210.22.000	D	145		
1.1 (187CXB/C)	01.1998 → 01.2010	176 B2.000	B	14	Series 315.8.18	06.1991 →	8060.25.4600	D	135		
STILO VAN (192_)					Series 315.8.18	06.1991 →	8060.45B.5160	D	136		
1.4 (192DXH1B)	01.2004 → 08.2008	843 A1.000	B	21	Series 50						
1.6 (192DXB1A)	04.2005 → 08.2008	182 B6.000	B	42	50N, 50NC	01.1972 → 12.1974	8040.02	D	127		
1.9 JTD (192DXE1A)	10.2001 → 08.2005	192 A1.000	D	51	Series 55						
1.9 JTD (192DXF1A)	10.2001 → 08.2005	192 A3.000	D	51	55N	01.1972 → 12.1976	8040.02	D	127		
1.9 JTD (192DXG1B)	09.2003 → 08.2005	192 A5.000	D	54	Series 600						
1.9 JTD (192DXG1B)	09.2003 → 08.2005	937 A4.000	D	55	645N3	01.1970 → 12.1972	8060.02.000	D	127		
1.9 JTD (192DXG1B)	02.2004 → 08.2008	192 B1.000	D	55	Series 65						
1.9 JTD (192DXS1A)	09.2005 → 08.2008	192 A8.000	D	51	65P	01.1975 → 12.1977	8040.02	D	127		
1.9 JTD (192DXT1B)	09.2005 → 08.2008	937 A5.000	D	55	65P	01.1975 → 12.1977	8040.02	D	127		
TALENTO Bus (290_)					65P	01.1977 → 12.1979	8040.02	D	127		
1.9 D (290UEHK)	03.1989 → 03.1994	149 B1.000	D	61	Series 70						
TALENTO Bus (296_)					70	1977 →	8340.05.000	D	139		
1.6 D	06.2016 →	R9M 413	D	39	70	09.1977 → 12.1980	8340.04.000	D	139		
1.6 D	06.2016 →	R9M 452	D	39	70	03.1985 → 12.1989	8045.06.306	D	127		
1.6 D	06.2016 →	R9M 452	D	39	70	03.1985 → 12.1989	8045.06.308	D	127		
TALENTO Platform/Chassis (290_)					70	03.1985 →	8045.06.208	D	127		
1.9 D (290UAK, 290UTK)	03.1989 → 03.1994	149 B1.000	D	61	70	01.1990 →	8045.06.307	D	127		
TALENTO Platform/Chassis (296_)					70	01.1990 →	8045.06.309	D	127		
1.6 D	06.2016 →	R9M 413	D	39	70-10	06.1977 → 01.1987	8340.06.000	D	139		
1.6 D	06.2016 →	R9M 452	D	39	Series 75						
1.6 D	06.2016 →	R9M 452	D	39	75-10	06.1977 → 01.1987	8340.06.000	D	139		
TALENTO Van (290_)					75-13	12.1985 → 12.1992	8060.05.270	D	136		
1.9 D (290UK)	03.1989 → 03.1994	149 B1.000	D	61	75-13	12.1985 → 12.1992	8060.05.280	D	136		
TALENTO Van (296_)					75P	01.1975 → 12.1977	8060.02.000	D	127		
1.6 D	06.2016 →	R9M 408	D	39	75P	01.1975 → 12.1977	8060.02.000	D	127		
1.6 D	06.2016 →	R9M 413	D	39	75P	01.1977 → 01.1979	8060.02.000	D	127		
1.6 D	06.2016 →	R9M 413	D	39	75P	09.1977 → 12.1977	8340.04.000	D	139		
1.6 D	06.2016 →	R9M 452	D	39	Series 80						
1.6 D	06.2016 →	R9M 452	D	39	80 F 13	04.1978 → 05.1980	8060.04.660	D	133		
TEMPRA S.W. (159_)					80-14	06.1986 →	8060.05.270	D	136		
1.4 (159AA)	04.1991 → 06.1993	159 A2.000	B	41	80-16	12.1982 → 12.1988	8060.24.001	D	134		
1.9 D (159AG)	07.1993 → 07.1996	160 A7.000	D	60	80-46	03.1984 → 12.1984	8035.02.276	D	127		
1.9 TD (159AI, 159BI)	04.1990 → 07.1996	160 A6.000	D	62	80N	01.1972 → 12.1976	8060.02.000	D	127		
UNO Van (146_)					80N	10.1984 → 12.1976	8045.05.206	D	136		
1.7 D	02.1988 → 02.1992	146 B2.000	D	60	80N	10.1984 → 12.1976	8045.05.306	D	136		
1.7 D	02.1988 → 02.1992	149 B4.046	D	60	80N	09.1986 → 12.1976	8045.05.208	D	136		
45 0.9	02.1988 → 07.1996	146 A.000	B	2	80N	09.1986 → 12.1976	8045.06.308	D	127		
45 0.9	02.1988 → 07.1996	146 A1.000	B	3	80N	01.1990 → 12.1976	8045.05.207	D	136		
					80N	01.1990 → 12.1976	8045.05.209	D	136		
					80N	01.1990 → 12.1976	8045.05.307	D	136		

				Pos					Pos
80N	01.1990 → 12.1976	8045.05.309	D	136	55-66	01.1985 → 12.1992	8035.06.307	D	127
80N	01.1990 → 12.1976	8045.06.309	D	127	55-66	01.1985 → 12.1992	8035.06.307	D	127
80N, 80NC	01.1972 → 12.1976	8060.02.000	D	127	55-66	01.1985 → 12.1992	8035.06.308	D	127
<b>Series 90</b>					55-66	01.1985 → 12.1992	8035.06.308	D	127
90-12	01.1977 →	8340.05.000	D	139	55-66	01.1985 → 12.1992	8035.06.323	D	127
90N, 90NC	01.1972 → 12.1976	8060.02.000	D	127	55-66	01.1985 → 12.1992	8035.06.323	D	127
90P	01.1975 → 12.1977	8060.02.000	D	127	55-66S	01.1996 → 12.1999	8035.06.206	D	127
90P	01.1975 → 12.1977	8060.02.000	D	127	55-66S	01.1996 → 12.1999	8035.06.208	D	127
90P	01.1977 → 12.1979	8060.02.000	D	127	55-66S	01.1996 → 12.1999	8035.06.222	D	127
90P	01.1977 → 12.1979	8060.02.000	D	127	55-66S	01.1996 → 12.1999	8035.06.307	D	127
95-14	07.1983 → 05.1991	8060.05.270	D	136	55-66S	01.1996 → 12.1999	8035.06.308	D	127
					65-66	01.1985 → 12.1991	8045.06.213	D	127
<b>1000</b>					65-66	01.1985 → 12.1991	8045.06.213	D	127
1000S	01.1976 → 12.1979	8065.04.200	D	133	65-66S	01.1996 → 12.1999	8045.06.213	D	127
1180	01.1979 → 12.1984	8065.04.200	D	133	70-66, 70-66S	01.1985 → 12.1999	8045.06.213	D	127
1180	01.1979 → 12.1984	8065.04.200	D	133	70-66, 70-66S	01.1985 → 12.1999	8045.06.306	D	127
1280	01.1979 → 12.1984	8065.24.300	D	133	70-66, 70-66S	03.1985 → 12.1999	8045.06.308	D	127
1280	04.1981 → 12.1983	8065.24.300	D	133	70-66, 70-66S	03.1985 → 12.1999	8045.06.309	D	127
1380	01.1979 → 12.1984	8065.24.000	D	133	70-66, 70-66S	06.1987 → 1990	8045.06.213	D	127
1380	01.1980 → 12.1983	8065.24.000	D	133	70-66, 70-66S	01.1990 → 12.1999	8045.06.307	D	127
1580	01.1980 → 12.1983	8365.05.500	D	139	80-66S	01.1992 → 12.1984	8035.02.276	D	127
1880	01.1980 → 12.1983	8365.25.500	D	139	80-66S	01.1992 → 12.1984	8045.02.276	D	127
<b>400</b>					80-66S	01.1992 → 12.1989	8045.05.206	D	136
400	01.1968 → 03.1986	8035.01.303	D	119	80-66S	01.1992 → 12.1989	8045.05.208	D	136
450	1970 → 1972	8035.02.376	D	127	80-66S	01.1992 → 12.1989	8045.05.306	D	136
450	1972 → 12.1981	8035.02.202	D	127	80-66S	01.1992 → 12.1996	8045.05.207	D	136
450	03.1976 → 09.1980	8035.01.303	D	119	80-66S	01.1992 → 12.1996	8045.05.209	D	136
466	1970 → 1972	8035.02.376	D	127	80-66S	01.1992 → 12.1996	8045.05.307	D	136
466	02.1982 → 12.1984	8035.02.276	D	127	80-66S	01.1992 → 12.1996	8045.05.309	D	136
480	01.1973 → 1972	8035.02.376	D	127	<b>700</b>				
480	1974 → 12.1984	8035.02.300	D	127	780	01.1978 → 02.1984	8045.04.270	D	133
480	01.1976 → 06.1978	8035.02.202	D	127	780	01.1978 → 12.1984	8045.04.270	D	133
480	06.1978 → 03.1982	8035.02.302	D	127	<b>800</b>				
<b>500 Serie</b>					880/5	01.1980 → 12.1984	8055.04.200	D	133
500	01.1971 → 1972	8035.02.376	D	127	880/5	03.1980 → 06.1984	8055.04.200	D	133
500	06.1973 → 12.1980	8035.02.201	D	127	<b>850 (100_)</b>				
500	06.1978 → 12.1980	8035.02.202	D	127	Series 855	02.1981 → 12.1984	8045.04.275	D	133
540	01.1971 → 1972	8035.02.376	D	127	<b>88</b>				
540	03.1972 → 12.1980	8035.02.202	D	127	55-88	01.1989 → 12.1993	8035.06.216	D	127
540	03.1972 → 12.1980	8035.02.302	D	127	55-88	01.1989 → 12.1993	8035.06.216	D	127
540	1981 → 12.1980	8035.02.300	D	127	55-88	01.1989 → 12.1993	8035.06.317	D	127
566	01.1982 → 12.1986	8035.04.265	D	133	55-88	01.1989 → 12.1993	8035.06.317	D	127
566	01.1982 → 12.1986	8035.04.265	D	133	65-88	01.1989 → 12.1993	8045.06.213	D	127
580	01.1978 → 02.1984	8035.04.270	D	133	65-88	01.1989 → 12.1993	8045.06.213	D	127
580	01.1978 → 12.1984	8035.04.270	D	133	65-88	01.1989 → 12.1993	8045.06.225	D	127
<b>600 Serie</b>					65-88	01.1989 → 12.1993	8045.06.225	D	127
640	01.1973 → 12.1980	8045.02.200	D	127	65-88	01.1989 → 12.1993	8045.06.319	D	127
666	02.1982 → 12.1984	8045.02.276	D	127	65-88	01.1989 → 12.1993	8045.06.319	D	127
666	02.1982 → 12.1984	8045.02.376	D	127	65-88	01.1989 → 12.1993	8045.06.326	D	127
680	01.1978 → 12.1983	8045.02.270	D	127	65-88	01.1989 → 12.1993	8045.06.326	D	127
680	01.1978 → 02.1984	8045.02.370	D	127	70-88	01.1989 → 12.1993	8045.06.200	D	127
<b>66</b>					70-88	01.1989 → 12.1993	8045.06.200	D	127
45-66	01.1985 → 12.1992	8035.06.200	D	127	70-88	01.1989 → 12.1993	8045.06.208	D	127
45-66	01.1985 → 12.1992	8035.06.200	D	127	70-88	01.1989 → 12.1993	8045.06.208	D	127
45-66	01.1985 → 12.1992	8035.06.220	D	127	<b>90</b>				
45-66	01.1985 → 12.1992	8035.06.220	D	127	110-90	10.1986 → 12.1988	8065.05.220	D	136
45-66	01.1985 → 12.1992	8035.06.222	D	127	115-90	01.1984 → 10.1990	8065.05.000	D	136
45-66	01.1985 → 12.1992	8035.06.222	D	127	115-90	01.1984 → 12.1990	8065.05.000	D	136
45-66	01.1985 → 12.1992	8035.06.321	D	127	130-90	01.1984 → 12.1990	8065.25.010	D	136
45-66	01.1985 → 12.1992	8035.06.321	D	127	130-90	05.1987 → 10.1990	8065.25.010	D	136
45-66	01.1985 → 12.1992	8035.06.323	D	127	180-90	01.1984 → 12.1994	8365.25.500	D	139
45-66	01.1985 → 12.1992	8035.06.323	D	127	55-90	01.1984 → 12.1992	8035.06.200	D	127
45-66	01.1985 → 12.1992	8035.06.323	D	127	55-90	01.1984 → 12.1992	8035.06.200	D	127
55-66	01.1985 → 12.1992	8035.06.206	D	127	60-90	03.1984 → 06.1989	8035.05.200	D	136
55-66	01.1985 → 12.1992	8035.06.206	D	127	65-90	01.1987 → 12.1992	8045.06.213	D	127
55-66	01.1985 → 12.1992	8035.06.208	D	127	65-90	01.1987 → 12.1992	8045.06.213	D	127
55-66	01.1985 → 12.1992	8035.06.208	D	127	70-90	01.1984 → 12.1992	8045.06.200	D	127
55-66	01.1985 → 12.1992	8035.06.222	D	127	70-90	01.1984 → 12.1992	8045.06.200	D	127
55-66	01.1985 → 12.1992	8035.06.222	D	127	70-90	01.1984 → 12.1992	8045.06.208	D	127

F

				Pos					Pos
70-90	01.1984 → 12.1992	8045.06.208	D	127	Series 45-66	02.1987 →	8035.06.222	D	127
90-90	01.1984 → 01.1991	8055.05.000	D	136	Series 45-66	02.1987 →	8035.06.323	D	127
90-90	01.1984 → 01.1991	8055.05.000	D	136	Series 45-66	01.1990 →	8035.06.321	D	127
<b>900</b>					Series 45-76	01.1985 →	8035.06.220	D	127
980	01.1979 → 12.1984	8065.02.200	D	127	Series 48	01.1988 →	D 3.152	D	103
980	01.1979 → 12.1984	8065.02.200	D	127	Series 49	01.1973 → 12.1990	8040.02.267	D	127
<b>94</b>					<b>SERIES 500</b>				
65-94	01.1993 → 12.1996	8045.06.225	D	127	Series 505	01.1970 → 1972	8035.02.376	D	127
65-94	01.1993 → 12.1996	8045.06.319	D	127	Series 505	1972 →	8035.02.202	D	127
65-94	01.1993 → 12.1996	8045.06.326	D	127	Series 505	12.1980 → 07.1982	8035.04.272	D	133
72-94	01.1993 → 08.1988	8045.06.200	D	127	Series 505	1981 →	8035.02.300	D	127
72-94	01.1993 → 12.1996	8045.06.301	D	127	<b>SERIES 520</b>				
82-94	01.1993 → 12.1996	8045.05.205	D	136	Series 520	01.1984 →	D 3.152	D	103
<b>F</b>					<b>SERIES 550</b>				
130	09.1990 →	8065.25.220	D	136	Series 550	01.1966 → 1971	8045.01	D	119
4 M	04.1985 → 12.1992	8035.05.265	D	136	Series 555	01.1966 → 1971	8045.01	D	119
F 100	01.1990 → 12.1993	8065.06.300	D	127	<b>SERIES 560</b>				
F 110	01.1990 → 12.1993	8065.05.220	D	136	Series 565	06.1982 → 12.1984	8035.04.376	D	133
F 115	01.1993 → 12.1996	8065.05.000	D	136	Series 566	12.1980 → 07.1982	8035.04.272	D	133
F 120	01.1990 → 12.1993	8065.05.000	D	136	Series 566	12.1980 → 12.1984	8035.04.378	D	133
F 130	01.1990 → 12.1996	8065.25.010	D	136	Series 566	02.1982 → 12.1984	8035.04.376	D	133
<b>L</b>					<b>SERIES 570</b>				
L65	01.1996 → 12.1998	8045.06.213	D	127	Series 570	12.1977 → 02.1982	8035.04.270	D	133
L65	01.1996 → 12.1998	8045.06.225	D	127	Series 570	09.1980 → 12.1984	8035.04.378	D	133
L65	01.1996 → 12.1998	8045.06.319	D	127	Series 570	1981 →	8035.04.300	D	133
L65	01.1996 → 12.1998	8045.06.326	D	127	Series 570	03.1982 → 12.1983	8035.04.272	D	133
<b>SERIES 10</b>					<b>SERIES 60</b>				
C	06.1978 → 12.1989	8365.05.570	D	139	Series 60 CL	03.1985 → 12.1989	8035.05.306	D	136
CLGP	01.1979 → 02.1985	8365.05.570	D	139	Series 60 CL	03.1985 →	8035.05.206	D	136
CLGP	01.1979 → 02.1986	8365.05.560	D	139	Series 60 CL	03.1985 →	8035.05.307	D	136
CTA	01.1979 → 02.1986	8365.05.570	D	139	Series 60 DT	03.1985 → 12.1989	8035.05.308	D	136
<b>SERIES 1000</b>					Series 60 DT	03.1985 →	8035.05.309	D	136
Series 1355	09.1981 → 04.1988	8365.05.590	D	139	Series 60 E 8	01.1983 → 04.1983	8040.04.200	D	133
<b>SERIES 220</b>					Series 60 F 8	06.1979 → 02.1982	8040.04.200	D	133
Series 225	01.1966 → 1971	806.000	D	119	Series 60 LM	09.1987 → 12.1990	8035.05.206	D	136
<b>SERIES 250</b>					Series 60 LM	09.1987 → 12.1990	8035.05.306	D	136
Series 250	01.1966 → 1971	8025.01	D	119	Series 60 LM	09.1987 → 12.1990	8035.05.307	D	136
Series 250	06.1984 → 1991	8210.22.000	D	145	Series 60 LM DT	01.1991 →	8035.05.206	D	136
Series 255	01.1968 → 12.1979	8025.01	D	119	Series 60 LM DT	01.1991 →	8035.05.306	D	136
<b>SERIES 30</b>					Series 60 LM DT	01.1991 →	8035.05.307	D	136
Series 35	01.1974 → 12.1978	8040.02.300	D	127	Series 60-46	10.1984 → 12.1988	8035.05.206	D	136
<b>SERIES 3000</b>					Series 60-46	10.1984 → 12.1988	8035.05.306	D	136
Series 3300		4.236	D	126	Series 60-56	10.1984 → 08.1988	8035.05.306	D	136
Series 3350	01.1970 → 1972	8065.02.217	D	127	Series 60-56	01.1989 →	8035.05.206	D	136
Series 3450		6.372.4	D	129	Series 60-56	01.1990 →	8035.05.307	D	136
Series 3450	1970 → 1972	8065.02.217	D	127	Series 60-65	10.1984 → 12.1989	8035.05.206	D	136
<b>SERIES 340</b>					Series 60-65	10.1984 → 12.1989	8035.05.306	D	136
Series 345	01.1972 → 01.1980	4.248	D	128	Series 60-66	09.1984 → 12.1989	8035.05.206	D	136
<b>SERIES 350</b>					Series 60-66	09.1984 → 12.1989	8035.05.306	D	136
Series 350	01.1974 → 12.1976	8025.02.001	D	127	Series 60-66	04.1985 → 06.1988	8035.05.208	D	136
Series 350	01.1974 → 12.1976	8025.02.004	D	127	Series 60-66	04.1985 → 06.1988	8035.05.308	D	136
Series 350	01.1974 → 12.1976	8025.02.304	D	127	Series 60-66	01.1990 →	8035.05.307	D	136
Series 355	01.1972 → 1972	8035.02.376	D	127	Series 60-66	1994 →	8035.05.309	D	136
Series 355	01.1972 →	8035.02.202	D	127	Series 60-66	03.1989 → 08.1988	8035.05.306	D	136
Series 355	01.1974 →	8025.02.311	D	127	Series 60-75	03.1989 →	8035.05.206	D	136
<b>SERIES 40</b>					Series 60-75	03.1989 →	8035.05.307	D	136
Series 40	09.1972 → 12.1990	8040.02.360	D	127	Series 60-85	06.1992 →	8035.05.208	D	136
Series 40	01.1973 → 12.1990	8040.02.267	D	127	Series 60-85	06.1992 →	8035.05.309	D	136
Series 40	01.1973 → 12.1990	8040.02.367	D	127	Series 60-86	06.1992 →	8035.05.208	D	136
Series 40	05.1981 → 12.1990	8040.02.300	D	127	Series 60-86	01.1997 →	8035.05.309	D	136
Series 40	02.1987 → 12.1990	8035.06.220	D	127	Series 60-88	11.1989 → 08.1988	8045.06.200	D	127
Series 40	02.1987 → 12.1990	8035.06.222	D	127	Series 60-88	11.1989 →	8045.06.216	D	127
Series 40	02.1987 → 12.1990	8035.06.323	D	127	Series 60-88	11.1989 →	8045.06.317	D	127
Series 45 DT	02.1987 →	8035.06.220	D	127	Series 65-46	04.1985 → 12.1988	8045.06.220	D	127
Series 45 DT	02.1987 →	8035.06.222	D	127	Series 65-46	04.1985 → 12.1988	8045.06.320	D	127
Series 45 DT	02.1987 →	8035.06.323	D	127	Series 65-56	06.1987 → 08.1988	8045.06.220	D	127
Series 45-66	09.1984 →	8035.06.220	D	127	Series 65-56	06.1987 → 08.1988	8045.06.320	D	127
Series 45-66	01.1985 → 08.1988	8035.06.206	D	127	Series 65-56	06.1987 → 08.1988	8045.06.321	D	127
Series 45-66	01.1985 →	8035.06.320	D	127	Series 65-66	06.1987 → 08.1988	8045.06.213	D	127



				Pos					Pos
Series 65-66	06.1987 → 08.1988	8045.06.220	D	127	25	01.1980 → 02.1986	8035.04.359	D	133
Series 65-66	06.1987 → 08.1988	8045.06.321	D	127	30	01.1973 → 11.1981	8045.02.359	D	127
Series 65-88	11.1989 → 08.1988	8045.06.200	D	127	30	01.1980 → 02.1986	8035.04.359	D	133
Series 65-88	11.1989 →	8045.06.219	D	127	30	07.1981 → 05.1985	8045.04.359	D	133
Series 65-88	11.1989 →	8045.06.319	D	127	30	06.1985 →	8045.05.359	D	136
Series 65-90	09.1987 → 08.1988	8045.06.225	D	127	35	01.1973 → 11.1981	8045.02.359	D	127
Series 65-90	09.1987 →	8045.06.213	D	127	35	07.1981 → 05.1985	8045.04.359	D	133
Series 65-90	09.1987 →	8045.06.326	D	127	35	06.1985 →	8045.05.359	D	136
Series 65-93	09.1987 → 08.1988	8045.06.225	D	127	40	01.1973 → 11.1981	8045.02.359	D	127
Series 65-93	09.1987 → 08.1988	8045.06.326	D	127	40	07.1981 → 05.1985	8045.04.359	D	133
Series 65-94	09.1987 → 08.1988	8045.06.225	D	127	40	06.1985 →	8045.05.359	D	136
Series 65-94	09.1987 → 08.1988	8045.06.326	D	127	45	06.1985 →	8045.05.359	D	136
Series 66-18	04.1978 → 12.1982	8040.04.200	D	133	50	01.1973 → 07.1981	8045.02.356	D	127
<b>SERIES 660</b>					50	06.1979 → 04.1985	8045.02.354	D	127
Series 665	06.1982 → 12.1984	8045.02.276	D	127	50	06.1985 →	8045.05.359	D	136
<b>SERIES 670</b>					60	06.1985 →	8045.05.359	D	136
Series 670	07.1977 → 04.1982	8045.02.270	D	127	70	01.1981 → 12.1981	8055.04.250	D	133
Series 670	07.1977 → 04.1982	8045.02.276	D	127	<b>SERIES DIM</b>				
Series 670	07.1977 → 04.1982	8045.02.376	D	127	20	01.1971 → 12.1982	8035.02.355	D	127
Series 670	1981 →	8045.02.370	D	127	25	01.1971 → 12.1982	8035.02.355	D	127
<b>SERIES 700</b>					30	01.1973 → 11.1981	8045.02.358	D	127
Series 700	01.1984 →	4.236	D	126	35	01.1973 → 11.1981	8045.02.358	D	127
<b>SERIES 760</b>					<b>SERIES DM</b>				
Series 765	06.1982 → 12.1984	8045.02.276	D	127	12	01.1971 → 12.1982	8035.02.350	D	127
Series 765	06.1982 → 12.1984	8045.04.276	D	133	15	01.1971 → 12.1982	8035.02.350	D	127
Series 766	02.1982 → 12.1984	8045.02.276	D	127	<b>SERIES FA</b>				
Series 766	02.1982 → 12.1984	8045.04.276	D	133	150	03.1984 → 11.1990	8365.25.500	D	139
Series 766	02.1982 → 12.1984	8045.04.300	D	133	200	01.1987 →	8460.21.002	D	142
Series 766	02.1982 → 12.1984	8045.04.376	D	133	<b>SERIES FB</b>				
<b>SERIES 820</b>					7	01.1984 → 01.1985	8045.04.293	D	133
Series 820	01.1984 →	4.236	D	126	7	12.1985 →	8045.05.393	D	136
<b>SERIES 840</b>					<b>SERIES FD</b>				
Series 840	01.1972 →	4.248	D	128	10	01.1986 →	8060.25.600	D	136
<b>SERIES 920</b>					14	12.1988 →	8365.25.500	D	139
Series 920	01.1984 →	4.248	D	128	208	01.1987 →	8460.21.002	D	142
<b>SERIES 950</b>					3	01.1972 →	4.107	D	32
Series 955	02.1981 → 12.1984	8055.04.205	D	133	5	03.1981 → 04.1985	8045.04.189	D	133
<b>SERIES 980</b>					5	05.1985 → 12.1992	8045.05.389	D	136
Series 980	09.1972 → 02.1982	8060.02.000	D	127	7	03.1986 →	8065.05.000	D	136
Series 980	01.1980 → 06.1984	8065.02.217	D	127	9	01.1986 →	8060.25.600	D	136
<b>SERIES A</b>					<b>SERIES FE</b>				
60-9	09.1988 → 12.1992	8040.05.200	D	136	10	01.1983 → 07.1985	8065.24.098	D	133
70	01.1990 →	8045.06.307	D	127	18	01.1978 → 12.1988	8065.24.000	D	133
70-14	05.1988 → 06.1991	8060.05.246	D	136	18	01.1982 → 07.1985	8065.04.097	D	133
90-14	05.1988 → 06.1991	8060.05.246	D	136	18	01.1983 → 03.1985	8065.24.098	D	133
<b>SERIES AC</b>					20	10.1981 → 12.1988	8365.05.530	D	139
160	01.1971 → 12.1975	D 3.152	D	103	20	10.1981 → 12.1988	8365.05.531	D	139
<b>SERIES ACF</b>					24	10.1983 → 12.1988	8365.05.530	D	139
110	01.1971 → 12.1972	4.203	D	102	24	10.1983 → 12.1988	8365.05.531	D	139
<b>SERIES ACP</b>					28	05.1982 → 12.1988	8365.25.500	D	139
40 / 50	01.1973 →	4.203	D	102	<b>SERIES FG</b>				
<b>SERIES AD</b>					75	02.1982 → 04.1990	8365.05.520	D	139
4	01.1970 →	8035.02.310	D	127	85	06.1981 → 04.1990	8365.25.500	D	139
4	01.1971 → 05.1979	8030.02	D	127	95	02.1982 →	8365.05.520	D	139
<b>SERIES D</b>					95	02.1982 →	8365.25.500	D	139
130/35	01.1974 →	8045.02.358	D	127	<b>SERIES FH</b>				
130/35	01.1974 →	8045.02.359	D	127	200	01.1986 →	8060.25.600	D	136
140	01.1974 →	8045.02.358	D	127	300	03.1989 →	8365.25.533	D	139
140	01.1974 →	8045.02.359	D	127	<b>SERIES FL</b>				
<b>SERIES DI</b>					10	01.1978 → 04.1988	8365.05.560	D	139
12	01.1971 → 12.1982	8035.02.353	D	127	14	01.1980 →	8365.25.500	D	139
12	10.1988 → 12.1990	M705 BA.19.0	D	60	4	11.1970 → 07.1978	8035.02.210	D	127
120	01.1974 →	8035.02.356	D	127	4	12.1977 →	8035.04.272	D	133
130	07.1981 → 12.1989	8365.05.555	D	139	4	1978 →	8035.04.378	D	133
15	01.1971 → 12.1982	8035.02.353	D	127	4 C	11.1970 → 07.1978	8035.02.261	D	127
15	10.1988 →	M705 BA.19.0	D	60	4 C	11.1970 → 07.1978	8035.02.361	D	127
20	01.1980 → 02.1986	8035.04.359	D	133	4 C	01.1971 → 05.1979	8030.02	D	127
20	10.1988 → 12.1990	M705 BA.19.0	D	60	4 C	01.1973 → 05.1979	8035.02.310	D	127
21	10.1988 →	M705 BA.19.0	D	60	4 D	11.1970 → 07.1978	8035.02.310	D	127

F



				Pos					Pos
4 D	11.1970 → 07.1978	8035.02.365	D	127	Series 55-65	10.1984 → 02.1989	8035.06.206	D	127
4 D	07.1973 → 07.1978	8035.02.265	D	127	Series 55-65	10.1984 → 02.1989	8035.06.306	D	127
4 L	11.1970 → 03.1985	8035.04.265	D	133	Series 55-65	01.1990 →	8035.06.307	D	127
4 M	01.1984 → 03.1985	8035.04.265	D	133	Series 55-66	09.1984 → 08.1988	8035.06.206	D	127
4 M	10.1987 → 12.1992	8035.05.265	D	136	Series 55-66	09.1984 →	8035.06.306	D	127
5	03.1981 → 04.1985	8045.04.189	D	133	Series 55-66	04.1985 → 06.1988	8035.06.208	D	127
5	05.1985 → 12.1992	8045.05.389	D	136	Series 55-66	04.1985 → 06.1988	8035.06.308	D	127
5	05.1985 → 12.1992	8045.05.393	D	136	Series 55-66	04.1985 → 08.1988	8035.06.322	D	127
55	01.1994 →	8035.02.201	D	127	Series 55-66	04.1985 → 12.1989	8035.06.222	D	127
7	03.1982 → 02.1986	8065.04.095	D	133	Series 55-66	04.1985 →	8035.06.323	D	127
7	03.1982 → 12.1992	8065.05.000	D	136	Series 55-66	01.1990 →	8035.06.307	D	127
<b>SERIES FR</b>					Series 55-75	03.1989 → 08.1988	8035.06.206	D	127
10	01.1978 →	8065.24.000	D	133	Series 55-75	03.1989 →	8035.06.306	D	127
10	02.1982 → 01.1985	8065.24.091	D	133	Series 55-76	01.1985 →	8035.06.220	D	127
12	1978 →	8065.24.000	D	133	Series 55-85	09.1992 →	8035.06.208	D	127
12	01.1982 → 12.1985	8065.24.092	D	133	Series 55-86	06.1992 →	8035.06.222	D	127
12	1986 →	8060.25.600	D	136	Series 55-86	06.1992 →	8035.06.223	D	127
130	01.1986 →	8060.25.600	D	136	Series 55-86	01.1997 →	8035.06.220	D	127
15	03.1982 → 11.1985	8365.05.580	D	139	Series 55-88	11.1989 →	8035.06.216	D	127
15	03.1982 → 06.1990	8365.25.500	D	139	Series 55-88	11.1989 →	8035.06.317	D	127
158	01.1980 →	8365.25.500	D	139	Series 55-90	03.1984 → 06.1989	8035.06.200	D	127
20	01.1982 → 12.1990	8215.22.542	D	145	<b>Series 600</b>				
20	01.1982 → 12.1990	8365.25.500	D	139	Series 600	01.1980 →	4.236	D	126
206	01.1987 →	8460.21.002	D	142	Series 605	01.1977 → 07.1982	8045.02.211	D	127
220	01.1987 →	8460.21.002	D	142	Series 612	01.1966 → 1971	8030.00	D	119
7	12.1982 →	8055.04.200	D	133	Series 616	01.1966 → 1971	8030.00	D	119
7	04.1988 →	8045.05.395	D	136	Series 616	1970 → 1972	8035.02.202	D	127
<b>SERIES M</b>					Series 616	1970 → 1972	8035.02.376	D	127
100	01.1996 → 12.1975	4.236	D	126	Series 616	01.1971 → 05.1979	8030.01	D	119
84	01.1969 → 12.1975	4.236	D	126	Series 616	01.1971 → 05.1979	8030.02	D	127
<b>SERIES R</b>					Series 616	01.1971 → 12.1981	8040.02	D	127
450	03.1976 → 09.1980	8035.01.303	D	119	Series 620	01.1984 →	D 4.203	D	103
<b>SERIES TX</b>					<b>Series 70</b>				
66	01.1987 →	8460.21.002	D	142	Series 70-56	01.1990 →	8045.06.307	D	127
<b>Series 110</b>					Series 70-65	10.1984 → 02.1989	8045.06.306	D	127
Series 110-90	11.1986 →	8065.05.220	D	136	Series 70-75	03.1989 → 08.1988	8045.06.306	D	127
<b>Series 120</b>					Series 70-75	03.1989 →	8045.06.307	D	127
Series 120	1979 →	8360.04.200	D	139	Series 70-76	01.1990 → 12.1998	8045.06.208	D	127
<b>Series 400</b>					Series 70-76	01.1990 → 12.1998	8045.06.309	D	127
Series 414	03.1982 → 12.1983	8035.02.312	D	127	Series 70-86	06.1992 →	8045.06.208	D	127
Series 446	06.1982 → 12.1984	8035.02.276	D	127	Series 70-86	06.1992 →	8045.06.309	D	127
Series 465	06.1982 → 12.1984	8035.02.276	D	127	Series 70-88	11.1989 →	8045.06.216	D	127
Series 474	04.1983 → 12.1984	8035.02.212	D	127	Series 70-88	11.1989 →	8045.06.317	D	127
<b>Series 50</b>					Series 70-90	03.1984 → 12.1998	8045.06.200	D	127
Series 50 DT	03.1985 →	8035.06.206	D	127	Series 70-90	03.1984 → 12.1998	8045.06.213	D	127
Series 50 DT	03.1985 →	8035.06.306	D	127	Series 70-90	08.1988 → 12.1998	8045.06.301	D	127
Series 50 DT	07.1986 → 12.1989	8035.06.320	D	127	Series 72-86	01.1994 → 12.1998	8045.06.208	D	127
Series 50-55	03.1985 → 12.1989	8035.06.306	D	127	Series 72-93		8045.06.301	D	127
Series 50-55	03.1985 →	8035.06.208	D	127	Series 72-93	04.1985 → 08.1988	8045.06.200	D	127
Series 50-55	03.1985 →	8035.06.307	D	127	Series 79-14	12.1985 → 01.1988	8060.05.270	D	136
Series 50-55	03.1985 →	8035.06.308	D	127	<b>Series 80</b>				
Series 50-55	03.1985 →	8035.06.309	D	127	Series 80-56	04.1984 → 12.1984	8035.04.376	D	133
Series 50-55	04.1985 →	8035.06.222	D	127	Series 80-65	10.1984 → 02.1989	8045.05.206	D	136
Series 50-55	04.1985 →	8035.06.323	D	127	Series 80-70	09.1980 → 03.1983	8045.02.211	D	127
Series 50-86	07.1986 →	8035.06.220	D	127	Series 80-70	09.1980 → 03.1983	8045.02.276	D	127
Series 50-9	06.1977 → 12.1979	8340.06.000	D	139	Series 80-75	03.1989 → 12.1989	8045.05.206	D	136
Series 55 C	03.1985 →	8035.06.208	D	127	Series 80-75	01.1990 →	8045.05.207	D	136
Series 55 DT	03.1985 → 12.1989	8035.06.308	D	127	Series 80-75	01.1990 →	8045.05.307	D	136
Series 55 DT	03.1985 →	8035.06.206	D	127	Series 80-76	03.1984 → 12.1984	8045.04.276	D	133
Series 55 DT	03.1985 →	8035.06.307	D	127	Series 80-88	11.1989 →	8045.05.216	D	136
Series 55 DT	03.1985 →	8035.06.323	D	127	Series 80-88	11.1989 →	8045.05.217	D	136
Series 55 DT	01.1990 →	8035.06.309	D	127	Series 80-88	11.1989 →	8045.05.317	D	136
Series 55 F 8	04.1978 → 06.1980	8040.04.200	D	133	Series 80-90	03.1984 →	8045.05.205	D	136
Series 55-46	10.1984 → 12.1988	8035.06.206	D	127	Series 80-90	08.1988 →	8045.05.204	D	136
Series 55-46	10.1984 → 12.1988	8035.06.306	D	127	Series 80-90	08.1988 →	8045.05.304	D	136
Series 55-46	01.1990 →	8035.06.307	D	127	Series 82-66	06.1992 →	8045.05.208	D	136
Series 55-56	10.1984 →	8035.06.306	D	127	Series 82-66	06.1992 →	8045.05.309	D	136
Series 55-56	01.1989 →	8035.06.206	D	127	Series 82-86	06.1992 → 12.1998	8045.05.208	D	136
Series 55-56	01.1989 →	8035.06.307	D	127	Series 82-86	06.1992 → 12.1998	8045.05.309	D	136

				Pos					Pos
Series 84	01.1969 → 12.1975	4.236	D	<b>126</b>					
Series 85-55	10.1984 → 06.1989	8045.05.200	D	<b>136</b>					
Series 85-55	10.1984 → 06.1989	8045.05.300	D	<b>136</b>					
Series 85-90	01.1991 →	8045.05.205	D	<b>136</b>					
<b>Series 90</b>									
Series 90-90	06.1984 → 08.1988	8045.05.200	D	<b>136</b>					
Series 90-90	05.1985 → 12.1991	8055.05.000	D	<b>136</b>					
Series 95-55	1987 → 12.1991	8055.05.000	D	<b>136</b>					
<b>TL</b>									
5	06.1973 → 1971	8045.01	D	<b>119</b>					
TL70	01.1998 → 12.2004	8045.06.200	D	<b>127</b>					
TL70	01.1998 → 12.2004	8045.06.208	D	<b>127</b>					

**F**

					Reference	Item No.	
<b>1</b>	<b>65</b>						
<b>100 GBC.000</b>	02.1968 → 12.1972	B		4	903 cm <sup>3</sup> 2V	38 kW (52 PS) 9,5:1	68,00 mm
<b>100 GBC.040</b>	02.1968 → 12.1972	B		4	903 cm <sup>3</sup> 2V	38 kW (52 PS) 9,5:1	68,00 mm
<b>100 GF 000</b>	01.1978 → 01.1986	B (NA)		4	903 cm <sup>3</sup> 2V	26 kW (35 PS) 7,8	68,00 mm
<b>100 GL.000</b>	09.1971 → 08.1989	B (NA)		4	903 cm <sup>3</sup> 2V	30-33 kW (41-45 PS) 9	68,00 mm
<b>100 GL.048</b>	06.1971 → 05.1983	B (NA)		4	903 cm <sup>3</sup> 2V	29 kW (40 PS) 7,8	68,00 mm
<b>100 GL.0N.0</b>		B		4	903 cm <sup>3</sup> 2V	33 kW (45 PS) 9:1	68,00 mm
<b>100 GL.3C.0</b>		B		4	903 cm <sup>3</sup> 2V	33 kW (45 PS) 9:1	68,00 mm
<b>100 GL.9C.0</b>		B		4	903 cm <sup>3</sup> 2V	33 kW (45 PS) 9:1	68,00 mm
<b>100 GL.9N.0</b>		B		4	903 cm <sup>3</sup> 2V	33 kW (45 PS) 9:1	68,00 mm
<b>100 GL3.000</b>	10.1980 → 06.1994	B		4	903 cm <sup>3</sup> 2V	33 kW (45 PS) 9	68,00 mm
<b>100 GL6.000</b>	05.1974 → 12.1985	B (NA)		4	843 cm <sup>3</sup> 2V	25 kW (34 PS) 8	63,60 mm
<b>141 B.000</b>	01.1986 → 07.1992	B (NA)		4	769 cm <sup>3</sup> 2V	25 kW (34 PS) 9,2	58,00 mm
<b>156 A4.000</b>	01.1986 → 10.2003	B (NA)		4	770 cm <sup>3</sup> 2V	25 kW (34 PS) 9,4	58,00 mm
<b>156 A4.048</b>		B (NA)		4	770 cm <sup>3</sup> 2V	25 kW (34 PS) 9,4	58,00 mm
[50]	∅ 7 mm						<b>RK-7</b>
[4]	13,00 x 7 x 42,2	G1				4 372 331 4265699	<b>81-1755</b>
<b>2</b>	<b>65</b>						
<b>146 A.000</b>	10.1980 → 07.1996	B (NA)		4	903 cm <sup>3</sup> 2V	33 kW (45 PS) 9	68,00 mm
[50]	∅ 7 mm						<b>RK-7</b>
[50]	∅ 8 mm						<b>RK-8</b>
[4]	13,00 x 7 x 42,2	G1				4 372 331 4265699	<b>81-1755</b>
[4]	14,07 x 8 x 46,0	G1				4 250 803	<b>81-17110</b>
[4]	14,10 x 8 x 42,0	G1				4 371 508	<b>81-1762</b>
<b>3</b>	<b>65</b>						
<b>1170 A1.000</b>	07.1991 → 07.1999	B (NA)		4	899 cm <sup>3</sup> 2V	29-30 kW (40-41 PS) 8,8:1	67,70 mm
<b>146 A1.000</b>	03.1983 → 07.1996	B (NA)		4	903 cm <sup>3</sup> 2V	33 kW (45 PS) 9	68,00 mm
<b>170 A1.000</b>	07.1991 → 12.1993	B		4	903 cm <sup>3</sup> 2V	30 kW (41 PS) 8,8	68,00 mm
[4]	13,00 x 7 x 42,2	G1				4 372 331 4265699	<b>81-1755</b>
<b>4</b>	<b>65</b>						
<b>1170 A1.046</b>	07.1991 →	B (NA)		4	899 cm <sup>3</sup> 2V	29 kW (39 PS) 8,8	67,70 mm
<b>170 A1.046</b>	07.1991 → 09.1994	B (NA)		4	903 cm <sup>3</sup> 2V	30 kW (41 PS) 8,8	68,00 mm
[4]	13,00 x 7 x 42,2	G1				4 372 331 4265699	<b>81-1755</b>
[8]	H 12 x 27					46427282	<b>50 007 616</b>
<b>5</b>	<b>67,2</b>						
<b>A 112 B1.054</b>	09.1982 → 12.1986	B (NA)		4	965 cm <sup>3</sup> 2V	35-36 kW (48-49 PS) 9,2	68,00 mm
[4]	13,00 x 7 x 42,2	G1				4 372 331 4265699	<b>81-1755</b>
<b>6</b>	<b>67,4</b>						
<b>110 F.000</b>	01.1965 → 12.1975	B (NA)		2	499 cm <sup>3</sup> 2V	13 kW (18 PS) 7,1	70,00 mm
<b>120.000</b>	01.1960 → 12.1975	B (NA)		2	499 cm <sup>3</sup> 2V	13 kW (18 PS) 7,1:1	70,00 mm
[4]	13,05 x 8 x 59,0	B1				987 064	<b>81-1729</b>

					Reference	Item No.		
<b>7</b>		<b>69,6</b>						
<b>169 A1.000</b>		D (A)	4	1248 cm <sup>3</sup>	4V	55 kW (75 PS) 17,6	82,00 mm	
<b>188 A9.000</b>	06.2003 →	D (A)	4	1248 cm <sup>3</sup>	4V	51-66 kW (70-90 PS) 18	82,00 mm	
<b>199 A2.000</b>	05.2005 →	D (A)	4	1248 cm <sup>3</sup>	4V	55-68 kW (75-93 PS) 18	82,00 mm	
41 287 6.., 41 289 6..								
	IN [2]	21,9 x 6 x 109,3	S - Cr -	- 45° -	-	22 - III	46518930 55195680 55219965	<b>291111</b>
	EX [2]	21,9 x 6 x 109,2	A/S - Cr -	- 45° -	-	22 - III	46518931 55202685 55208213	<b>291112</b>
	[50]	Ø 6 mm						<b>MK-6H</b>
	IN/EX [4]	10,03 x 6.02 x 43,0	G2				46816601	<b>81-4221</b> <small>NEW</small>
	AS ES						46823507 46823508	<b>50 007 024</b> <small>NEW</small> (1) <b>50 007 572</b> (1)
(1) Schalenhartguss/chilled cast iron/pièce moulée trempée en surface/fundición en coquilla/Отливка с отбеленным поверхностным слоем								
	[8]	H 12 x 34 x 34					46475925	<b>50 006 438</b>
	[4]						73501138	<b>50 006 484</b>
<b>8</b>		<b>69,6</b>						
<b>188 A8.000</b>	09.2003 →	D (A)	4	1248 cm <sup>3</sup>	4V	51 kW (70 PS) 18	82,00 mm	
41 289 6..								
	IN [2]	21,9 x 6 x 109,3	S - Cr -	- 45° -	-	22 - III	46518930 55195680 55219965	<b>291111</b>
	EX [2]	21,9 x 6 x 109,2	A/S - Cr -	- 45° -	-	22 - III	46518931 55202685 55208213	<b>291112</b>
	[50]	Ø 6 mm						<b>MK-6H</b>
	IN/EX [4]	10,03 x 6.02 x 43,0	G2				46816601	<b>81-4221</b> <small>NEW</small>
	[8]	H 12 x 34 x 34					46475925	<b>50 006 438</b>
	[4]						73501138	<b>50 006 484</b>
<b>9</b>		<b>69,6</b>						
<b>199 A3.000</b>	04.2005 →	D (A)	4	1248 cm <sup>3</sup>	4V	63-70 kW (86-95 PS) 18	82,00 mm	
<b>223 A9.000</b>	10.2005 →	D (A)	4	1248 cm <sup>3</sup>	4V	62 kW (84 PS) 17,6	82,00 mm	
40 659 6..								
	IN [2]	21,9 x 6 x 109,2	S - Cr -	- 45° -	-	22 - III		<b>291129</b>
	EX [2]	22,5 x 6 x 109,2	A/S - Cr -	- 45° -	-	22 - III		<b>291130</b>
	[50]	Ø 6 mm						<b>MK-6H</b>
Fortsetzung nächste Seite / continued on next page / suite page suivante / continuación página próxima / Продолжение на следующей странице								

**F**

					Reference	Item No.
IN/EX [4]	10,03 x 6.02 x 43,0	G2			46816601	<b>81-4221</b>
	AS ES				46823507 46823508	<b>50 007 024</b> (1) <b>50 007 572</b> (1)
	(1) Schalenhartguss/chilled cast iron/pièce moulée trempée en surface/fundición en coquilla/Отливка с отбеленным поверхностным слоем					
[8]	H 12 x 34 x 34				46475925	<b>50 006 438</b>
[4]					73501138	<b>50 006 484</b>

**F**

<b>10</b>		<b>69,6</b>
<b>169 A5.000</b>	06.2006 → 08.2013	D (A) 4 1248 cm <sup>3</sup> 4V 55 kW (75 PS) 16,8 82,00 mm

IN [2]	21,9 x 6 x 109,3	S - Cr -	- 45° - -	22 - III	46518930 55195680 55219965	<b>291111</b>
EX [2]	21,9 x 6 x 109,2	A/S - Cr -	- 45° - -	22 - III	46518931 55202685 55208213	<b>291112</b>
[50]	Ø 6 mm					<b>MK-6H</b>
IN/EX [4]	10,03 x 6.02 x 43,0	G2			46816601	<b>81-4221</b>
	AS ES				55206897 55206898	<b>50 007 799</b> <b>50 007 800</b>
[8]	H 12 x 34 x 34				46475925	<b>50 006 438</b>
[4]					73501138	<b>50 006 484</b>

<b>11</b>		<b>69,6</b>
<b>199 A1.000</b>	01.2007 →	D (A) 4 1248 cm <sup>3</sup> 4V 55 kW (75 PS) 16,8 82,00 mm
<b>263 A2.000 Euro 5</b>	02.2010 →	D (A) 4 1248 cm <sup>3</sup> 4V 66 kW (90 PS) 16,8 82,00 mm
40 659 6..		

	AS ES				55206897 55206898	<b>50 007 799</b> <b>50 007 800</b>
--	----------	--	--	--	----------------------	--

<b>12</b>		<b>69,6</b>
<b>199 A9.000 Euro 5</b>	11.2007 →	D (A) 4 1248 cm <sup>3</sup> 4V 55-59 kW (75-80 PS) 17,6 82,00 mm
<b>199 B1.000 Euro 5</b>	05.2008 →	D (A) 4 1248 cm <sup>3</sup> 4V 64-70 kW (87-95 PS) 16,8 82,00 mm
<b>199 B2.000 Euro 5</b>	07.2008 →	D (A) 4 1248 cm <sup>3</sup> 4V 51 kW (69 PS) 17,6 82,00 mm
<b>199 B4.000 Filter</b>	10.2009 →	D (A) 4 1248 cm <sup>3</sup> 4V 62 kW (84 PS) 16,8 82,00 mm
41 288 6.., 41 289 6..		

IN [2]	21,9 x 6 x 109,2	S - Cr -	- 45° - -	22 - III		<b>291129</b>
EX [2]	22,5 x 6 x 109,2	A/S - Cr -	- 45° - -	22 - III		<b>291130</b>
[50]	Ø 6 mm					<b>MK-6H</b>
IN/EX [4]	10,03 x 6.02 x 43,0	G2			46816601	<b>81-4221</b>
	AS ES				55206897 55206898	<b>50 007 799</b> <b>50 007 800</b>

Fortsetzung nächste Seite / continued on next page / suite page suivante / continuación página próxima / Продолжение на следующей странице



					Reference	Item No.
[8]	H 12 x 34 x 34				46475925	50 006 438
[4]					73501138	50 006 484
<b>13</b>	<b>69,6</b>					
<b>199 B8.000</b>	12.2013 →	D (A)	4	1248 cm <sup>3</sup>	4V 59 kW (80 PS)	82,00 mm
IN/EX [4]	10,03 x 6.02 x 43,0	G2			46816601	<b>81-4221</b>
<b>14</b>	<b>70</b>					
<b>156 A2.000</b>	10.1984 → 10.1995	B (NA)	4	999 cm <sup>3</sup>	2V 31-37 kW (42-50 PS)	9,5 64,90 mm
<b>156 A2.246</b>	10.1984 →	B (NA)	4	999 cm <sup>3</sup>	2V 33-40 kW (45-54 PS)	9,5 64,90 mm
<b>156 A3.000</b>	01.1985 → 12.1992	B (NA)	4	999 cm <sup>3</sup>	2V 37 kW (50 PS)	9,8 64,90 mm
<b>156 A3.100</b>	01.1986 → 02.1992	B (NA)	4	999 cm <sup>3</sup>	2V 32-33 kW (44-45 PS)	9,5 64,90 mm
<b>156 C.046</b>	01.1990 → 07.2004	B (NA)	4	1108 cm <sup>3</sup>	2V 37-43 kW (50-58 PS)	9,6 72,00 mm
<b>160 A3.000</b>	04.1986 →	B (NA)	4	1108 cm <sup>3</sup>	2V 36-43 kW (56-58 PS)	9,6 72,00 mm
<b>176 A6.000</b>	09.1993 → 09.1999	B (NA)	4	1108 cm <sup>3</sup>	2V 40 kW (54 PS)	9,6 72,00 mm
<b>176 B2.000</b>	09.1993 → 01.2010	B (NA)	4	1108 cm <sup>3</sup>	2V 40 kW (54 PS)	9,6 72,00 mm
94 910 7..						
EX [2]	27,5 x 7 x 97,1	A - Cr -		- 45° - VS -	1 -	5 942 728 7 666 227
[50]	Ø 7 mm					<b>RK-7</b>
IN/EX [4]	13,00 x 7 x 42,2	G1				4 372 331 4265699
<b>15</b>	<b>70</b>					
<b>156 A2.048</b>	06.1986 → 12.1993	B (NA)	4	999 cm <sup>3</sup>	2V 32 kW (44 PS)	9,2 64,90 mm
<b>156 A2.100</b>	01.1986 → 12.1993	B (NA)	4	999 cm <sup>3</sup>	2V 32-33 kW (44-45 PS)	9 64,90 mm
<b>187 A1.000</b>	02.1995 →	B (NA)	4	1108 cm <sup>3</sup>	2V 40-42 kW (54-57 PS)	9,6 72,00 mm
IN/EX [4]	13,00 x 7 x 42,2	G1				4 372 331 4265699
<b>16</b>	<b>70,8</b>					
<b>176 A7.000</b>	01.1994 → 06.2000	B (NA)	4	1242 cm <sup>3</sup>	2V 43-44 kW (58-60 PS)	9,6 78,90 mm
<b>176 A8.000</b>	10.1993 →	B (NA)	4	1242 cm <sup>3</sup>	2V 54 kW (73 PS)	9,8 78,90 mm
<b>176 B1.000</b>	09.1993 → 06.2000	B (NA)	4	1242 cm <sup>3</sup>	2V 44 kW (60 PS)	10,2 78,90 mm
94 870 7..						
EX [2]	27,5 x 7 x 97,1	A - Cr -		- 45° - VS -	1 -	5 942 728 7 666 227
[50]	Ø 7 mm					<b>RK-7</b>
IN/EX [4]	13,00 x 7 x 42,2	G1				4 372 331 4265699
<b>17</b>	<b>70,8</b>					
<b>176 B4.000</b>	09.1993 → 06.2000	B (NA)	4	1242 cm <sup>3</sup>	2V 44 kW (60 PS)	9,8 78,90 mm
<b>178 E2.000</b>	06.1998 →	B (NA)	4	1242 cm <sup>3</sup>	2V 50-54 kW (68-73 PS)	9,8 78,90 mm
<b>188 A4.000</b>	07.1997 →	B (NA)	4	1242 cm <sup>3</sup>	2V 38-44 kW (52-60 PS)	9,5-9,8 78,90 mm
<b>223 A5.000</b>	03.2001 →	B (NA)	4	1242 cm <sup>3</sup>	2V 48 kW (65 PS)	9,8 78,90 mm
94 870 7..						
IN/EX [4]	13,00 x 7 x 42,2	G1				4 372 331 4265699

F

					Reference	Item No.		
<b>18</b>		<b>70,8</b>						
<b>176 B9.000</b>		B (NA)	4	1242 cm <sup>3</sup>	4V	63 kW (86 PS) 10,2	78,90 mm	
<b>182 B2.000</b>	10.1998 → 05.2005	B (NA)	4	1242 cm <sup>3</sup>	4V	60-64 kW (82-87 PS) 10,2:1	78,90 mm	
<b>188 A5.000</b>	09.1999 →	B (NA)	4	1242 cm <sup>3</sup>	4V	57-60 kW (78-82 PS) 10,6	78,90 mm	
	IN [2]	26,8 x 6 x 95,0	S - Cr -	- 45° -	-	22 - III	46403681	<b>171052</b>
	EX [2]	22,4 x 6 x 96,2	A - Cr -	- 45° -	-	22 -	46471639	<b>171053</b>
	[8]	H 33 x 24 x 24					46787055 73503122	<b>50 006 422</b>
<b>19</b>		<b>70,8</b>						
<b>169 A4.000</b>	07.2007 →	B (NA)	4	1242 cm <sup>3</sup>	2V	51 kW (69 PS) 11,1	78,90 mm	
<b>199 A4.000 Euro 4</b>	10.2005 →	B (NA)	4	1242 cm <sup>3</sup>	2V	48-51 kW (65-69 PS) 11	78,90 mm	
41 754 6..								
	IN [2]	33,2 x 5 x 99,9	S - Cr -	- 45° -	-	22 - III	5 519 4219 5 520 0334 5 521 9143	<b>171117</b>
	EX [2]	28,0 x 5 x 100,5	RA/S- Cr -	- 45° -	VS -	22 - III	5 520 0335 5 520 0422 5 521 9144	<b>171118</b>
	[50]	∅ 5 mm						<b>MK-5H</b>
<b>20</b>		<b>72</b>						
<b>350 A1.000 Euro 4/5</b>	10.2002 →	B (NA)	4	1368 cm <sup>3</sup>	2V	51-63 kW (69-86 PS) 11	84,00 mm	
	IN [2]	33,2 x 5 x 99,9	S - Cr -	- 45° -	-	22 - III	5 519 4219 5 520 0334 5 521 9143	<b>171117</b>
	EX [2]	28,0 x 5 x 100,5	RA/S- Cr -	- 45° -	VS -	22 - III	5 520 0335 5 520 0422 5 521 9144	<b>171118</b>
	[50]	∅ 5 mm						<b>MK-5H</b>
							55195803	<b>50 007 685</b> (1)
(1) Schalenhartguss/chilled cast iron/pièce moulée trempée en surface/fundición en coquilla/Отливка с отбелнным поверхностным слоем								
<b>21</b>		<b>72</b>						
<b>169 A3.000</b>	10.2006 →	B (NA)	4	1368 cm <sup>3</sup>	4V	74-79 kW (100-107 PS) 10,8:1	84,00 mm	
<b>192 B2.000</b>	12.2003 →	B (NA)	4	1368 cm <sup>3</sup>	4V	66 kW (90 PS) 11	84,00 mm	
<b>199 A6.000</b>	10.2005 → 08.2011	B (NA)	4	1368 cm <sup>3</sup>	4V	70-71 kW (95-97 PS) 11	84,00 mm	
<b>843 A1.000</b>	09.2003 →	B (NA)	4	1368 cm <sup>3</sup>	4V	65-71 kW (88-97 PS) 10,8	84,00 mm	
	[8]	H 28,4 x 26					55193839	<b>50 007 620</b>
<b>22</b>		<b>72</b>						
<b>199 A7.000</b>	10.2005 →	B (NA)	4	1368 cm <sup>3</sup>	2V	55 kW (75 PS) 11	84,00 mm	
	IN [2]	33,2 x 5 x 99,9	S - Cr -	- 45° -	-	22 - III	5 519 4219 5 520 0334 5 521 9143	<b>171117</b>
	EX [2]	28,0 x 5 x 100,5	RA/S- Cr -	- 45° -	VS -	22 - III	5 520 0335 5 520 0422 5 521 9144	<b>171118</b>
	[50]	∅ 5 mm						<b>MK-5H</b>

					Reference	Item No.		
<b>23</b>	<b>72</b>							
<b>198 A1.000</b>	09.2007 →	B (A)	4	1368 cm <sup>3</sup>	4V	104-112 kW (141-152 PS)	9,6-10	84,00 mm
<b>198 A4.000</b>	05.2007 →	B (A)	4	1368 cm <sup>3</sup>	4V	88 kW (120 PS)	9,6-10	84,00 mm
41 729 6..								
	IN [2]	26,9 x 6 x 95,2	S - Cr -	- 45° -	-	22 - III	55185028	<b>171125</b>
	EX [2]	22,4 x 6 x 94,6	RA/S- Cr -	- 45° -	VS -	22 - III	55185080	<b>171126</b>
	[50]	∅ 6 mm						<b>MK-6H</b>
	IN/EX [4]	10,05 x 5 x 46,5	G1					<b>81-4220</b>
	[8]	H 28,4 x 26					55193839	<b>50 007 620</b>
<b>24</b>	<b>73,5</b>							
<b>126 A.000</b>	09.1972 → 06.1977	B (NA)	2	594 cm <sup>3</sup>	2V	17 kW (23 PS)	7,5	70,00 mm
<b>126 AB.0C.0</b>		B (NA)	2	594 cm <sup>3</sup>	2V	17 kW (23 PS)	7,5:1	70,00 mm
<b>126 AB.5C.0</b>		B (NA)	2	594 cm <sup>3</sup>	2V	13 kW (18 PS)	7,5:1	70,00 mm
	IN/EX [4]	14,20 x 8.03 x 59,0	G1					<b>81-1761</b>
<b>25</b>	<b>75</b>							
<b>9HU</b>	01.2007 →	D (A)	4	1560 cm <sup>3</sup>	4V	66 kW (90 PS)	18	88,30 mm
40 179 6..								
	IN [2]	25,6 x 5,5 x 96,4	S - Cr -	- 45° -	-	22 - III	9645024780	<b>539009</b>
	EX [2]	23,4 x 5,5 x 96,6	A/S - Cr -	- 45° -	VS -	22 - III	9640840080	<b>539010</b>
	[50]	∅ 5,5 mm						<b>MK-5.5H</b>
	IN/EX [4]	9,55 x 5.51 x 34,0	G1					<b>81-18111</b>
<b>26</b>	<b>75</b>							
<b>9HM (DV6UC)</b>	02.2011 →	D (A)	4	1560 cm <sup>3</sup>	2V	66 kW (90 PS)	18	88,30 mm
	IN [2]	30,0 x 5,5 x 95,5	S - Cr -	- 45° -	-	22 - III		<b>539046</b>
	EX [2]	27,6 x 5,5 x 95,5	RA/S- Cr -	- 45° -	VS -	22 - III		<b>539047</b>
	[50]	∅ 5,5 mm						<b>MK-5.5H</b>
	IN/EX [4]	9,55 x 5.51 x 34,0	G1					<b>81-18111</b>
<b>27</b>	<b>76</b>							
<b>127 AB.0C.0</b>		B	4	1049 cm <sup>3</sup>	2V	37 kW (50 PS)	9,3:1	57,80 mm
<b>127 AB.ON.0</b>		B	4	1049 cm <sup>3</sup>	2V	37 kW (50 PS)	9,3:1	57,80 mm
<b>127 AJ.0C.0</b>		B	4	1049 cm <sup>3</sup>	2V	37 kW (50 PS)	9,3:1	57,80 mm
	[50]	∅ 8 mm						<b>RK-8</b>
<b>28</b>	<b>76,1</b>							
<b>156 A.000</b>	11.1976 → 10.1989	B (NA)	4	1049 cm <sup>3</sup>	2V	37-41 kW (50-56 PS)	9,5	57,80 mm
	IN/EX [4]	13,00 x 7 x 42,2	G1				4 372 331 4265699	<b>81-1755</b>

**F**

					Reference	Item No.	
<b>29</b>	<b>76,1</b>						
<b>127A.046</b>	06.1982 → 10.1987	B	(NA)	4	1049 cm <sup>3</sup> 2V	37 kW (50 PS) 9,5 57,80 mm	
[50]	Ø 8 mm					<b>RK-8</b>	
<b>30</b>	<b>77</b>						
<b>126 A1.000</b>	07.1977 → 09.1987	B	(NA)	2	652 cm <sup>3</sup> 2V	17 kW (23 PS) 7,5:1 70,00 mm	
IN/EX [4]	14,20 x 8.03 x 59,0	G1				<b>81-1761</b>	
<b>31</b>	<b>78</b>						
<b>131 C1.000</b>	11.1980 → 01.1984	B	(NA)	4	1367 cm <sup>3</sup> 2V	51-55 kW (69-75 PS) 8,9:1 71,50 mm	
[50]	Ø 8 mm					<b>RK-8</b>	
IN [4]	14,10 x 8 x 42,0	G1			4 371 508	<b>81-1762</b>	
<b>32</b>	<b>79,37</b>						
<b>4.107</b>	01.1972 →	D	(NA)	4	1760 cm <sup>3</sup> 2V	30-40 kW (41-55 PS) 22.1 88,90 mm	
IN/EX [4]	12,74 x 8 x 62,0	G1				<b>81-85005</b>	
<b>33</b>	<b>79,5</b>						
<b>198 A3.000</b>	09.2007 →	D	(A)	4	1598 cm <sup>3</sup> 4V	77 kW (105 PS) 16,5 80,50 mm	
41 086 6..							
IN [2]	26,6 x 5 x 114,4	S - Cr -	- 45° -	-	22 - III	55225891	<b>171124</b> <small>NEW</small>
EX [2]	24,2 x 5 x 114,3	A/S - Cr -	- 45° -	-	22 - III	55205183	<b>291116</b>
[50]	Ø 5 mm						<b>MK-5H</b>
IN/EX [4]	10,05 x 5 x 46,5	G1					<b>81-4220</b> <small>NEW</small>
[8]	H 12 x 34 x 34					46475925	<b>50 006 438</b>
<b>34</b>	<b>79,5</b>						
<b>198 A6.000</b>	03.2008 → 12.2014	D	(A)	4	1598 cm <sup>3</sup> 4V	66 kW (90 PS) 16,5 80,50 mm	
IN [2]	26,6 x 5 x 114,4	S - Cr -	- 45° -	-	22 - III	55225891	<b>171124</b> <small>NEW</small>
IN [2]	27,8 x 5 x 114,4	S - Cr -	- 45° -	-	22 - III	55206431	<b>291114</b>
IN [2]	27,8 x 6 x 114,4	S - Cr -	- 45° -	-	22 - III	46802049	<b>291113</b>
						55195535	
						55202556	
EX [2]	24,2 x 5 x 114,3	A/S - Cr -	- 45° -	-	22 - III	55205183	<b>291116</b>
EX [2]	25,8 x 6 x 114,4	A/S - Cr -	- 45° -	VS -	22 - III	46787902	<b>291115</b>
						55202557	
[50]	Ø 5 mm						<b>MK-5H</b>
[50]	Ø 6 mm						<b>MK-6H</b>
IN/EX [4]	10,05 x 5 x 46,5	G1					<b>81-4220</b> <small>NEW</small>
[8]	H 12 x 34 x 34					46475925	<b>50 006 438</b>

					Reference	Item No.		
<b>35</b>		<b>79,5</b>						
<b>198 A2.000</b>	03.2008 → 12.2014	D (A)	4	1598 cm <sup>3</sup>	4V	88 kW (120 PS)	16,1-16,9	80,50 mm
<b>350 A2.000 Euro 5</b>	05.2008 →	D (A)	4	1598 cm <sup>3</sup>	4V	85-88 kW (116-120 PS)	16,5	80,50 mm
<b>955 A3.000 Euro 5</b>	07.2008 →	D (A)	4	1598 cm <sup>3</sup>	4V	88 kW (120 PS)	16,5	80,50 mm
<b>955 A4.000</b>		D (A)	4	1598 cm <sup>3</sup>	4V	85 kW (115 PS)	16,5:1	80,50 mm
	IN [2] IN [2]	27,8 x 5 x 114,4 27,8 x 6 x 114,4	S - Cr - S - Cr -	- 45° - - 45° -	- -	22 - III 22 - III	55206431 46802049 55195535 55202556	<b>291114</b> <b>291113</b>
	EX [2] EX [2]	24,2 x 5 x 114,3 25,8 x 6 x 114,4	A/S - Cr - A/S - Cr -	- 45° - - 45° -	- VS -	22 - III 22 - III	55205183 46787902 55202557	<b>291116</b> <b>291115</b>
	[50] [50]	∅ 5 mm ∅ 6 mm						<b>MK-5H</b> <b>MK-6H</b>
	IN/EX [4]	10,05 x 5 x 46,5	G1					<b>81-4220</b> <small>NEW</small>
	[8]	H 12 x 34 x 34				46475925		<b>50 006 438</b>
<b>36</b>		<b>79,5</b>						
<b>263 A3.000 Euro 5</b>	02.2010 →	D (A)	4	1598 cm <sup>3</sup>	4V	74 kW (101 PS)	16,5	80,50 mm
41 086 6..								
	[8]	H 12 x 34 x 34				46475925		<b>50 006 438</b>
<b>37</b>		<b>80</b>						
<b>138 B.000</b>	08.1980 → 08.1989	B (NA)	4	1116 cm <sup>3</sup>	2V	40-44 kW (55-60 PS)	9,2	55,50 mm
<b>138 B1.000</b>	10.1982 → 12.1987	B (NA)	4	1116 cm <sup>3</sup>	2V	40 kW (55 PS)	9,6	55,50 mm
<b>138 C1.000</b>	10.1982 → 12.1987	B (NA)	4	1116 cm <sup>3</sup>	2V	40-42 kW (55-57 PS)	9,2	55,50 mm
<b>146 A4.000</b>	08.1980 → 08.1988	B (NA)	4	1116 cm <sup>3</sup>	2V	43-44 kW (58-60 PS)	9,2	55,50 mm
<b>146 A4.048</b>	04.1985 → 06.2006	B (NA)	4	1116 cm <sup>3</sup>	2V	43 kW (58 PS)	9,2	55,50 mm
	[50]	∅ 8 mm						<b>RK-8</b>
	IN/EX [4] IN [4]	14,07 x 8 x 46,0 14,10 x 8 x 42,0	G1 G1			4 250 803 4 371 508		<b>81-17110</b> <b>81-1762</b>
<b>38</b>		<b>80</b>						
<b>128 BB.0A0</b>		B (NA)	4	1116 cm <sup>3</sup>	2V	48 kW (65 PS)	8,8:1	55,50 mm
<b>138 AE 0A.0</b>		B (NA)	4	1116 cm <sup>3</sup>	2V	44 kW (60 PS)	9,2:1	55,50 mm
	[50]	∅ 8 mm						<b>RK-8</b>
<b>39</b>		<b>80</b>						
<b>R9M 408</b>	06.2016 →	D (A)	4	1598 cm <sup>3</sup>	4V	66-85 kW (90-116 PS)	15,4	79,50 mm
<b>R9M 413</b>	06.2016 →	D (A)	4	1598 cm <sup>3</sup>	4V	70-89 kW (95-121 PS)	15,4	79,50 mm
<b>R9M 450</b>		D (A)	4	1598 cm <sup>3</sup>	4V	88-103 kW (120-140 PS)	15,4	79,50 mm
<b>R9M 452</b>	06.2016 →	D (A)	4	1598 cm <sup>3</sup>	4V	92-107 kW (125-145 PS)	15,4	79,50 mm
40 892 6..								
	IN [2] EX [2]	23,5 x 6 x 104,2 23,4 x 6 x 104,1	S - - RA/S- -	- 45° - - 45° -	- -	22 - III 22 - III		<b>539044</b> <small>NEW</small> <b>539045</b> <small>NEW</small>
	[50]	∅ 6 mm						<b>MK-6H</b>
Fortsetzung nächste Seite / continued on next page / suite page suivante / continuación página próxima / Продолжение на следующей странице								

**F**



					Reference	Item No.
[4]					6000616566	<b>50 007 711</b>
<b>40</b>		<b>80,5</b>				
<b>160 A1.000</b>	07.1987 → 12.1989	B (NA)	4	1372 cm <sup>3</sup> 2V	52-56 kW (71-76 PS)	9,2 67,40 mm
IN/EX [4]	14,07 x 8 x 46,0	G1			4 250 803	<b>81-17110</b>
IN [4]	14,10 x 8 x 42,0	G1			4 371 508	<b>81-1762</b>
<b>41</b>		<b>80,5</b>				
<b>146 C1.000</b>	09.1989 → 12.1993	B (NA)	4	1372 cm <sup>3</sup> 2V	51-57 kW (69-78 PS)	9,2 67,40 mm
<b>159 A2.000</b>	05.1989 → 08.1996	B (NA)	4	1372 cm <sup>3</sup> 2V	51-57 kW (69-78 PS)	9,2 67,40 mm
[50]	∅ 8 mm					<b>RK-8</b>
IN/EX [4]	14,07 x 8 x 46,0	G1			4 250 803	<b>81-17110</b>
IN [4]	14,10 x 8 x 42,0	G1			4 371 508	<b>81-1762</b>
<b>42</b>		<b>80,5</b>				
<b>182 B6.000</b>	06.1996 →	B (NA)	4	1596 cm <sup>3</sup> 4V	68-100 kW (92-136 PS)	10,5 78,40 mm
41 933 6..						
IN [2]	30,3 x 7 x 102,5	S - Cr -	- 45° -	- 9 - III	4 641 3806 4 646 2158 4 651 7325 4 676 1369 5 518 3592 5 519 2067	<b>171036</b>
EX [2]	30,0 x 7 x 102,4	A/S - Cr -	- 45° - VS -	9 -	46 461 209	<b>171037</b>
[50]	∅ 7 mm					<b>RK-7</b>
[50]	∅ 8 mm					<b>RK-8</b>
IN/EX [4]	13,00 x 7 x 42,2	G1			4 372 331 4265699	<b>81-1755</b>
IN [4]	13,03 x 7 x 42,5	G2			608 11 086 7 757 052	<b>81-17122</b>
EX [4]	13,03 x 7 x 46,0	G2			608 11 089 7 779 402	<b>81-17123</b>
[8]	H 33 x 24 x 24				46787055 73503122	<b>50 006 422</b>
<b>43</b>		<b>80,5</b>				
<b>939 A4.000</b>	12.2005 →	B (NA)	4	1796 cm <sup>3</sup> 4V	96-103 kW (131-140 PS)	10,5:1 88,20 mm
IN [2]	31,2 x 5 x 113,8	S - Cr -	- 45° -	- 22 -	5 555 7741	<b>291117</b>
EX [2]	27,5 x 5 x 113,2	A/S - Cr -	- 45° - VS -	22 -	2 440 5815 5 535 5572 7 174 4388	<b>291118</b>
[50]	∅ 5 mm					<b>MK-5H</b>
IN/EX [4]	10,04 x 4.98 x 37,0	G1			71739771	<b>81-4219</b>
<b>44</b>		<b>80,5</b>				
<b>178 E7.000</b>	06.2006 →	B (NA)	4	1596 cm <sup>3</sup> 4V	74-75 kW (101-102 PS)	10,5 78,40 mm
[8]	H 33 x 24 x 24				46787055 73503122	<b>50 006 422</b>

					Reference	Item No.		
<b>45</b>		<b>82</b>						
<b>182 A2.000</b>	10.1995 → 05.2002	B (NA)	4	1747 cm <sup>3</sup>	4V	83 kW (113 PS)	10,3	82,70 mm
<b>182 B7.000</b>	07.1998 → 02.2003	B (NA)	5	1998 cm <sup>3</sup>	4V	113 kW (154 PS)	10,7	75,65 mm
<b>183 A1.000</b>	04.1995 → 03.2012	B (NA)	4	1747 cm <sup>3</sup>	4V	92-97 kW (125-132 PS)	10,3	82,70 mm
<b>188 A6.000</b>	05.1998 → 03.2012	B (NA)	4	1747 cm <sup>3</sup>	4V	96 kW (130 PS)	10,3	82,70 mm
<b>192 A4.000</b>	10.2001 → 08.2008	B (NA)	4	1747 cm <sup>3</sup>	4V	90-98 kW (122-133 PS)	10,3	82,70 mm
	EX [2]	28,0 x 7 x 108,6	A	- Cr -	- 45° - VS -	22 -	7 766 565	<b>171004</b>
	[50]	∅ 7 mm						<b>MK-7H</b>
	IN [4]	13,03 x 7 x 42,5	G2				608 11 086 7 757 052	<b>81-17122</b>
	EX [4]	13,03 x 7 x 46,0	G2				608 11 089 7 779 402	<b>81-17123</b>
	[8]	H 33 x 24 x 24					46787055 73503122	<b>50 006 422</b>
<b>46</b>		<b>82</b>						
<b>175 A3.000</b>	08.1996 → 08.2000	B (A)	5	1998 cm <sup>3</sup>	4V	162 kW (220 PS)	8,5	75,70 mm
<b>182 A1.000</b>	10.1995 → 04.1999	B (NA)	5	1998 cm <sup>3</sup>	4V	108-113 kW (147-154 PS)	10	75,70 mm
<b>182 B3.000</b>	05.1998 → 08.2000	B (NA)	5	1998 cm <sup>3</sup>	4V	113 kW (154 PS)	10	75,65 mm
	IN [2]	30,0 x 7 x 113,2	S	- Cr -	- 45° -	22 - III	7 735 898	<b>171005</b>
	EX [2]	26,0 x 7 x 108,8	A	- Cr -	- 45° - VS -	22 -	7 735 899	<b>171003</b>
	[50]	∅ 7 mm						<b>MK-7H</b>
	IN [4]	13,03 x 7 x 42,5	G2				608 11 086 7 757 052	<b>81-17122</b>
	EX [4]	13,03 x 7 x 46,0	G2				608 11 089 7 779 402	<b>81-17123</b>
	[8]	H 33 x 24 x 24					46787055 73503122	<b>50 006 422</b>
<b>47</b>		<b>82</b>						
<b>182 A3.000</b>	10.1995 → 05.2002	B (NA)	4	1370 cm <sup>3</sup>	3V	59 kW (80 PS)	9,8	64,80 mm
	[50]	∅ 7 mm						<b>RK-7</b>
	IN [4]	13,03 x 7 x 42,5	G2				608 11 086 7 757 052	<b>81-17122</b>
	EX [4]	13,03 x 7 x 46,0	G2				608 11 089 7 779 402	<b>81-17123</b>
	EX [4]						46471599	<b>50 007 618</b>
<b>48</b>		<b>82</b>						
<b>182 A5.000</b>	10.1995 → 05.2005	B (NA)	4	1370 cm <sup>3</sup>	3V	55 kW (75 PS)	9,8	64,90 mm
	IN [4]	13,03 x 7 x 42,5	G2				608 11 086 7 757 052	<b>81-17122</b>
	EX [4]	13,03 x 7 x 46,0	G2				608 11 089 7 779 402	<b>81-17123</b>
	EX [4]						46471599	<b>50 007 618</b>

**F**

					Reference	Item No.	
<b>49</b>		<b>82</b>					
<b>185 A8.000 Euro 3</b>	01.2001 → 05.2002	B (NA)	5	1998 cm <sup>3</sup> 4V	110 kW (150 PS)	10,5 75,70 mm	
	IN [2]	30,0 x 7 x 113,2	S - Cr -	- 45° - -	22 - III	7 735 898	<b>171005</b>
	EX [2]	26,0 x 7 x 108,8	A - Cr -	- 45° - VS -	22 -	7 735 899	<b>171003</b>
	EX [2]	28,0 x 7 x 108,6	A - Cr -	- 45° - VS -	22 -	7 766 565	<b>171004</b>
	[50]	∅ 7 mm					<b>MK-7H</b>
	IN [4]	13,03 x 7 x 42,5	G2			608 11 086	<b>81-17122</b>
	EX [4]	13,03 x 7 x 46,0	G2			7 757 052 608 11 089 7 779 402	<b>81-17123</b>
	[8]	H 33 x 24 x 24				46787055 73503122	<b>50 006 422</b>
<b>50</b>		<b>82</b>					
<b>182 A7.000</b>	03.1996 → 05.2005	D (A)	4	1910 cm <sup>3</sup> 2V	74 kW (100 PS)	20,7 90,40 mm	
<b>182 A8.000</b>	03.1996 → 05.2005	D (A)	4	1910 cm <sup>3</sup> 2V	55 kW (75 PS)	20,7 90,40 mm	
<b>185 A2.000</b>	09.1996 → 04.1999	D (A)	5	2387 cm <sup>3</sup> 2V	91 kW (125 PS)	20,7 90,40 mm	
	EX [2]	31,0 x 8 x 114,3	A/S - Cr -	- 45° - VS -	22 - III	4 652 7856 7 783 225	<b>171014</b>
	[50]	∅ 8 mm					<b>MK-8H</b>
	IN/EX [4]	14,03 x 8.02 x 43,0	G1				<b>81-17129</b>
	IN/EX [4]	14,06 x 8.02 x 43,0	G1			46433782	<b>81-17128</b>
<b>51</b>		<b>82</b>					
<b>182 B9.000 Euro 3</b>	09.1996 →	D (A)	4	1910 cm <sup>3</sup> 2V	74-79 kW (100-107 PS)	18,45 90,40 mm	
<b>186 A6.000</b>	08.2000 → 09.2002	D (A)	4	1910 cm <sup>3</sup> 2V	81 kW (110 PS)	18,45 90,40 mm	
<b>186 A9.000</b>	04.2002 →	D (A)	4	1910 cm <sup>3</sup> 2V	88 kW (120 PS)	18:1 90,40 mm	
<b>188 A2.000</b>	09.1999 →	D (A)	4	1910 cm <sup>3</sup> 2V	59 kW (80 PS)	18,4 90,40 mm	
<b>188 B2.000</b>	06.2003 →	D (A)	4	1910 cm <sup>3</sup> 2V	74 kW (101 PS)	18 90,40 mm	
<b>192 A1.000</b>	10.2001 → 12.2009	D (A)	4	1910 cm <sup>3</sup> 2V	85 kW (115 PS)	18,5 90,40 mm	
<b>192 A3.000</b>	10.2001 → 08.2008	D (A)	4	1910 cm <sup>3</sup> 2V	59 kW (80 PS)	18,5 90,40 mm	
<b>192 A8.000</b>	09.2005 → 12.2014	D (A)	4	1910 cm <sup>3</sup> 2V	88 kW (120 PS)	18:1 90,40 mm	
<b>192 A9.000</b>	09.2005 → 08.2008	D (A)	4	1910 cm <sup>3</sup> 2V	74 kW (100 PS)	18,45 90,40 mm	
<b>199 A5.000</b>	10.2005 →	D (A)	4	1910 cm <sup>3</sup> 2V	96 kW (131 PS)	18 90,40 mm	
<b>223 B2.000</b>	10.2001 →	D (A)	4	1910 cm <sup>3</sup> 2V	74 kW (100 PS)	18,5 90,40 mm	
<b>937 A7.000</b>	10.2001 → 08.2008	D (A)	4	1910 cm <sup>3</sup> 2V	85 kW (115 PS)	18,45:1 90,40 mm	
41 795 6..							
	IN [2]	35,5 x 8 x 115,0	A/S - Cr -	- 45° - -	22 - III	46478834 46750859 55193126	<b>171046</b>
	EX [2]	34,5 x 8 x 115,1	A/S - Cr -	- 45° - -	22 - III	46416321 46783962 55202630	<b>171062</b>
	[50]	∅ 8 mm					<b>MK-8H</b>
	IN/EX [4]	14,03 x 8.02 x 43,0	G1				<b>81-17129</b>
	IN/EX [4]	14,06 x 8.02 x 43,0	G1			46433782	<b>81-17128</b>
						46772393	<b>50 007 038</b> (1)
	(1) Schalenhartguss/chilled cast iron/pièce moulée trempée en surface/fundición en coquilla/Отливка с отбелсным поверхностным слоем						

					Reference	Item No.			
<b>52</b>		<b>82</b>							
<b>182 B4.000</b>	12.1998 → 06.2010	D (A)	4	1910 cm <sup>3</sup>	2V	77-79 kW (105-107 PS)	18,45	90,40 mm	
<b>185 A6.000</b>	04.1999 → 05.2002	D (A)	5	2387 cm <sup>3</sup>	2V	96 kW (130 PS)	18,45	90,40 mm	
<b>185 B4.000</b>		D (LA)	4	1910 cm <sup>3</sup>	2V	77 kW (105 PS)	18,45:1	90,40 mm	
<b>186 A8.000</b>	07.2002 → 06.2010	D (A)	4	1910 cm <sup>3</sup>	2V	85 kW (115 PS)	18,45:1	90,40 mm	
<b>188 A3.000</b>	09.1999 → 03.2012	D (NA)	4	1910 cm <sup>3</sup>	2V	44 kW (60 PS)	22,5	90,40 mm	
<b>188 A7.000</b>	02.2000 → 03.2012	D (A)	4	1910 cm <sup>3</sup>	2V	63 kW (86 PS)	18,5	90,40 mm	
<b>223 A6.000 Euro 3</b>	12.2000 →	D (NA)	4	1910 cm <sup>3</sup>	2V	46-48 kW (63-65 PS)	22,6	90,40 mm	
<b>839 A5.000</b>	04.1999 → 05.2002	D (LA)	5	2387 cm <sup>3</sup>	2V	96-99 kW (131-135 PS)	18,5	90,40 mm	
<b>D19AA</b>	06.2006 → 10.2011	D (A)	4	1910 cm <sup>3</sup>	2V	88 kW (120 PS)	18	90,40 mm	
41 795 6.., 94 966 6..									
	IN [2]	35,5 x 8 x 115,0	A/S - Cr -	- 45° -	-	22 - III	46478834 46750859 55193126	<b>171046</b>	
	EX [2]	34,5 x 8 x 115,1	A/S - Cr -	- 45° -	-	22 - III	46416321 46783962 55202630	<b>171062</b>	
	[50]	Ø 8 mm						<b>MK-8H</b>	
	IN/EX [4]	14,03 x 8.02 x 43,0	G1					<b>81-17129</b>	
	IN/EX [4]	14,06 x 8.02 x 43,0	G1			46433782		<b>81-17128</b>	
<b>53</b>		<b>82</b>							
<b>223 A7.000</b>	07.2003 →	D (A)	4	1910 cm <sup>3</sup>	2V	77 kW (105 PS)	18,5	90,40 mm	
<b>223 B1.000</b>	07.2003 →	D (A)	4	1910 cm <sup>3</sup>	2V	77 kW (105 PS)	18,5	90,40 mm	
41 795 6..									
	IN/EX [4]	14,03 x 8.02 x 43,0	G1					<b>81-17129</b>	
	IN/EX [4]	14,06 x 8.02 x 43,0	G1			46433782		<b>81-17128</b>	
						46772393		<b>50 007 038</b> (1)	
	(1) Schalenhartguss/chilled cast iron/pièce moulée trempée en surface/fundición en coquilla/Отливка с отбеленным поверхностным слоем								
<b>54</b>		<b>82</b>							
<b>192 A5.000</b>	09.2003 → 08.2008	D (A)	4	1910 cm <sup>3</sup>	4V	103 kW (140 PS)	18,5	90,40 mm	
	IN [2]	27,8 x 5 x 114,4	S - Cr -	- 45° -	-	22 - III	55206431	<b>291114</b>	
	IN [2]	27,8 x 6 x 114,4	S - Cr -	- 45° -	-	22 - III	46802049 55195535 55202556	<b>291113</b>	
	EX [2]	24,2 x 5 x 114,3	A/S - Cr -	- 45° -	-	22 - III	55205183	<b>291116</b>	
	EX [2]	25,8 x 6 x 114,4	A/S - Cr -	- 45° -	VS -	22 - III	46787902 55202557	<b>291115</b>	
	[50]	Ø 5 mm						<b>MK-5H</b>	
	[50]	Ø 6 mm						<b>MK-6H</b>	
	IN/EX [4]	10,05 x 5 x 46,5	G1					<b>81-4220</b>	
		ES				46802052		<b>50 007 104</b>	
		AS				73501374		<b>50 007 105</b>	
		ES				55206425		<b>50 007 777</b>	
	[8]	H 12 x 34 x 34				46475925		<b>50 006 438</b>	
	[8]	H 12 x 34,6 x 34,6				46767972 9464396380 9632372480		<b>50 006 432</b>	

**F**

					Reference	Item No.	
<b>55</b>	<b>82</b>						
<b>192 B1.000</b>	02.2004 → 08.2008	D (A)	4	1910 cm <sup>3</sup> 4V	100 kW (136 PS)	18,5 90,40 mm	
<b>937 A4.000</b>	09.2003 → 08.2008	D (A)	4	1910 cm <sup>3</sup> 4V	93 kW (126 PS)	18,45:1 90,40 mm	
<b>937 A5.000</b>	09.2005 → 12.2014	D (A)	4	1910 cm <sup>3</sup> 4V	110 kW (150 PS)	17,5 90,40 mm	
<b>939 A2.000</b>	06.2005 → 12.2011	D (A)	4	1910 cm <sup>3</sup> 4V	110 kW (150 PS)	17,5 90,40 mm	
40 660 6..							
	IN [2] IN [2]	27,8 x 5 x 114,4 27,8 x 6 x 114,4	S - Cr - S - Cr -	- 45° - - - 45° - -	22 - III 22 - III	55206431 46802049 55195535 55202556	<b>291114</b> <b>291113</b>
	EX [2] EX [2]	24,2 x 5 x 114,3 25,8 x 6 x 114,4	A/S - Cr - A/S - Cr -	- 45° - - - 45° - VS -	22 - III 22 - III	55205183 46787902 55202557	<b>291116</b> <b>291115</b>
	[50] [50]	∅ 5 mm ∅ 6 mm					<b>MK-5H</b> <b>MK-6H</b>
	IN/EX [4]	10,05 x 5 x 46,5	G1				<b>81-4220</b>
		ES AS ES				46802052 73501374 55206425	<b>50 007 104</b> <b>50 007 105</b> <b>50 007 777</b>
	[8] [8]	H 12 x 34 x 34 H 12 x 34,6 x 34,6				46475925 46767972 9464396380 9632372480	<b>50 006 438</b> <b>50 006 432</b>
	[4] [4]					55200333 46764765	<b>50 007 612</b> <b>50 007 613</b>
<b>56</b>	<b>82</b>						
<b>939 A1.000</b>	06.2005 →	D (A)	4	1910 cm <sup>3</sup> 2V	88 kW (120 PS)	18:1 90,40 mm	
41 795 6..							
	IN [2] IN [2]	27,8 x 5 x 114,4 27,8 x 6 x 114,4	S - Cr - S - Cr -	- 45° - - - 45° - -	22 - III 22 - III	55206431 46802049 55195535 55202556	<b>291114</b> <b>291113</b>
	EX [2] EX [2]	24,2 x 5 x 114,3 25,8 x 6 x 114,4	A/S - Cr - A/S - Cr -	- 45° - - - 45° - VS -	22 - III 22 - III	55205183 46787902 55202557	<b>291116</b> <b>291115</b>
	[50] [50]	∅ 5 mm ∅ 6 mm					<b>MK-5H</b> <b>MK-6H</b>
	IN/EX [4]	10,05 x 5 x 46,5	G1				<b>81-4220</b>
						46772393	<b>50 007 038</b> (1)
		(1) Schalenhartguss/chilled cast iron/pièce moulée trempée en surface/fundición en coquilla/Отливка с отбелсным поверхностным слоем					
	[8]	H 12 x 34 x 34				46475925	<b>50 006 438</b>
<b>57</b>	<b>82</b>						
<b>939 A3.000</b>	06.2005 →	D (A)	5	2387 cm <sup>3</sup> 4V	147 kW (200 PS)	17:1 90,40 mm	
Fortsetzung nächste Seite / continued on next page / suite page suivante / continuación página próxima / Продолжение на следующей странице							



					Reference	Item No.
	IN [2] 27,8 x 5 x 114,4 IN [2] 27,8 x 6 x 114,4	S - Cr - S - Cr -	- 45° - - 45° -	22 - III 22 - III	55206431 46802049 55195535 55202556	<b>291114</b> <b>291113</b>
	EX [2] 24,2 x 5 x 114,3 EX [2] 25,8 x 6 x 114,4	A/S - Cr - A/S - Cr -	- 45° - - 45° - VS -	22 - III 22 - III	55205183 46787902 55202557	<b>291116</b> <b>291115</b>
	[50] Ø 5 mm [50] Ø 6 mm					<b>MK-5H</b> <b>MK-6H</b>
	IN/EX [4] 10,05 x 5 x 46,5	G1				<b>81-4220</b> <small>NEW</small>
	[8] H 12 x 34 x 34				46475925	<b>50 006 438</b>

**F**

<b>58</b>		<b>82,2</b>								
	<b>WJY (DW8) Euro 2</b>	04.1998 → 12.2006	D (NA)	4	1868 cm <sup>3</sup>	2V	51 kW	(69 PS)	23	88,00 mm
	491 mm									<b>50 006 220</b> (1)
	(1) Schalenhartguss/chilled cast iron/pièce moulée trempée en surface/fundición en coquilla/Отливка с отбеленным поверхностным слоем									

<b>59</b>		<b>82,2</b>								
	<b>WJY (DW8B) Euro 2</b>	04.1998 → 12.2006	D (NA)	4	1868 cm <sup>3</sup>	2V	51 kW	(69 PS)	23	88,00 mm
	<b>WJZ (DW8) Euro 2</b>	04.1998 → 12.2006	D (NA)	4	1868 cm <sup>3</sup>	2V	51-52 kW	(69-71 PS)	23	88,00 mm
	IN [2] 38,5 x 8 x 112,4 EX [2] 33,0 x 8 x 111,8	S - Cr - A - Cr -	- 45° - - 45° -	1 - III 1 -						<b>537746</b> <b>537747</b> (1)
	(1) Ventil Sitz/valve seat/siège de soupape/asiento de válvula/седло клапана 3,3 mm									
	[50] Ø 8 mm									<b>KK-8H</b>
	IN/EX [4] 14,05 x 8 x 48,0 IN/EX [4] 14,06 x 8 x 52,2 IN/EX [4] 14,07 x 8 x 50,0 IN/EX [4] 14,29 x 8 x 52,2	B1 B1 B1 B1								<b>81-5326</b> <b>81-5320</b> <b>81-5314</b> <b>81-5317</b>
	491 mm									<b>50 006 220</b> (2)
	(2) Schalenhartguss/chilled cast iron/pièce moulée trempée en surface/fundición en coquilla/Отливка с отбеленным поверхностным слоем									

<b>60</b>		<b>82,6</b>								
<b>146 B2.000</b>	01.1987 →	D (NA)	4	1698 cm <sup>3</sup>	2V	42-44 kW	(57-60 PS)	20,5	79,20 mm	
<b>146 D7.000</b>	01.1997 → 05.2001	D (A)	4	1698 cm <sup>3</sup>	2V	46 kW	(63 PS)	20	79,20 mm	
<b>149 A1.000</b>	04.1984 → 08.1996	D (NA)	4	1929 cm <sup>3</sup>	2V	48 kW	(65 PS)	21	90,00 mm	
<b>149 B4.046</b>	02.1988 → 02.1992	D (NA)	4	1697 cm <sup>3</sup>	2V	42-44 kW	(57-60 PS)	20	79,20 mm	
<b>154 B.000</b>		D (LA)	4	1929 cm <sup>3</sup>	2V	68 kW	(92 PS)	20:1	90,00 mm	
<b>160 A7.000</b>	02.1990 → 10.2001	D (NA)	4	1929 cm <sup>3</sup>	2V	48 kW	(65 PS)	21	90,00 mm	
<b>176 A3.000</b>	01.1994 →	D (A)	4	1698 cm <sup>3</sup>	2V	51-53 kW	(69-72 PS)	20,3	79,20 mm	
<b>176 B3.000</b>	04.1996 →	D (NA)	4	1698 cm <sup>3</sup>	2V	42 kW	(57 PS)	20,5	79,20 mm	
<b>176 B7.000</b>	09.1996 → 12.2009	D (A)	4	1698 cm <sup>3</sup>	2V	46-47 kW	(63-64 PS)	19,1	79,20 mm	
<b>230 A2.000</b>	03.1994 → 04.2002	D (NA)	4	1929 cm <sup>3</sup>	2V	51 kW	(70 PS)	20	90,00 mm	
<b>831 D1.000</b>	12.1985 → 07.1989	D (A)	4	1929 cm <sup>3</sup>	2V	59 kW	(80 PS)	20:1	90,00 mm	
<b>M705 BA.19.0</b>	10.1988 →	D	4	1929 cm <sup>3</sup>	2V	27 kW	(37 PS)	20:1	90,00 mm	
<b>M707 AT.19.0</b>		D (LA)	4	1929 cm <sup>3</sup>	2V	59 kW	(80 PS)	20:1	90,00 mm	
	[50] Ø 8 mm									<b>RK-8</b>

Fortsetzung nächste Seite / continued on next page / suite page suivante / continuación página próxima / Продолжение на следующей странице

					Reference	Item No.	
	IN/EX [4] IN [4]	14,07 x 8 x 46,0 14,10 x 8 x 42,0	G1 G1		4 250 803 4 371 508	<b>81-17110</b> <b>81-1762</b>	
<b>61</b>		<b>82,6</b>					
<b>149 B1.000</b>	02.1987 → 05.1994	D (NA) 4	1929 cm <sup>3</sup> 2V	51-52 kW (70-71 PS)	21	90,00 mm	
<b>149 B3.000</b>	05.1985 → 10.2001	D (NA) 4	1698 cm <sup>3</sup> 2V	44 kW (60 PS)	20,5	79,20 mm	
<b>149 B4.000</b>	01.1988 → 10.1995	D (NA) 4	1697 cm <sup>3</sup> 2V	42-45 kW (57-61 PS)	20	79,20 mm	
<b>280 A1.000</b>	03.1989 → 03.1994	D (A) 4	1929 cm <sup>3</sup> 2V	60 kW (82 PS)	20	90,00 mm	
	[50]	Ø 8 mm				<b>RK-8</b>	
	IN/EX [4] IN [4]	14,07 x 8 x 46,0 14,10 x 8 x 42,0	G1 G1		4 250 803 4 371 508	<b>81-17110</b> <b>81-1762</b>	
					5950297	<b>50 007 567</b> (1)	
	(1) Schalenhartguss/chilled cast iron/pièce moulée trempée en surface/fundición en coquilla/Отливка с отбелнным поверхностным слоем						
<b>62</b>		<b>82,6</b>					
<b>160 A6.000</b>	02.1990 → 12.1996	D (A) 4	1929 cm <sup>3</sup> 2V	66-68 kW (90-92 PS)	19,2	90,00 mm	
<b>160 A6.046</b>	04.1990 → 04.1995	D (A) 4	1929 cm <sup>3</sup> 2V	66-69 kW (90-94 PS)	19,2	90,00 mm	
<b>160 B6.046</b>	03.1992 → 08.1996	D (A) 4	1929 cm <sup>3</sup> 2V	59 kW (82 PS)	19,2:1	90,00 mm	
	EX [2]	33,5 x 8 x 116,5	A - Cr -	- 45° - VS -	9 -	7 588 577 7588577	<b>17061</b>
	[50]	Ø 8 mm				<b>RK-8</b>	
	IN/EX [4] IN [4]	14,07 x 8 x 46,0 14,10 x 8 x 42,0	G1 G1		4 250 803 4 371 508	<b>81-17110</b> <b>81-1762</b>	
					46552984	<b>50 006 189</b>	
<b>63</b>		<b>82,6</b>					
<b>176 A5.000</b>	01.1994 →	D (A) 4	1698 cm <sup>3</sup> 2V	52-59 kW (71-80 PS)	19,1	79,20 mm	
	[50]	Ø 8 mm				<b>RK-8</b>	
	IN/EX [4] IN [4]	14,07 x 8 x 46,0 14,10 x 8 x 42,0	G1 G1		4 250 803 4 371 508	<b>81-17110</b> <b>81-1762</b>	
					46552984	<b>50 006 189</b>	
<b>64</b>		<b>83</b>					
<b>LFW (XU7JP) Euro 2</b>	05.1997 → 08.2002	B (NA) 4	1761 cm <sup>3</sup> 2V	73 kW (99 PS)	9,5	81,40 mm	
	IN [2]	41,6 x 8 x 108,8	S - -	- 45° - -	1 - III	<b>537853</b>	
	EX [2]	34,5 x 8 x 108,4	A/S - Cr -	- 45° - VS -	1 - III	<b>537851</b>	
	[50]	Ø 8 mm				<b>KK-8H</b>	
	IN [4]	13,07 x 8 x 38,7	B1			<b>81-5322</b>	
	IN [4]	13,29 x 8 x 38,7	B1			<b>81-5315</b>	
	EX [4]	13,07 x 8 x 45,0	B1			<b>81-5323</b>	
	EX [4]	13,27 x 8 x 45,0	B1			<b>81-5316</b>	
<b>65</b>		<b>83</b>					
<b>192 A2.000</b>	10.2001 → 09.2007	B (NA) 5	2446 cm <sup>3</sup> 4V	117-125 kW (159-170 PS)	10,5	90,40 mm	
Fortsetzung nächste Seite / continued on next page / suite page suivante / continuación página próxima / Продолжение на следующей странице							

					Reference	Item No.
IN [2] EX [2]	33,6 x 7 x 113,1 28,1 x 7 x 108,5	S - Cr - A/S - Cr -	- 45° - - - 45° - VS -	22 - III 22 - III		<b>560017</b> <b>560018</b>
[50]	Ø 7 mm					<b>MK-7H</b>
IN [4] EX [4]	13,03 x 7 x 42,5 13,03 x 7 x 46,0	G2 G2			608 11 086 7 757 052 608 11 089 7 779 402	<b>81-17122</b> <b>81-17123</b>
[8]	H 33 x 24 x 24				46787055 73503122	<b>50 006 422</b>

**F**
**66**
**83**

**D8B** 02.1996 → 12.2006 D (A) 4 1905 cm<sup>3</sup> 2V 68 kW (92 PS) 21,8:1 88,00 mm  
**DHX (XUD9TF/L)** 02.1995 → 12.2006 D (LA) 4 1905 cm<sup>3</sup> 2V 66-68 kW (90-92 PS) 21,8 88,00 mm  
 94 786 7..

IN [2] EX [2] EX [2]	38,5 x 8 x 112,4 33,0 x 8 x 111,8 33,0 x 8 x 112,0	S - - A - Cr - A - Cr -	- 45° - - - 45° - - - 45° - -	1 - III 1 - 1 -	9 630 5973 80  9 613 7362 80	<b>531005</b> <b>537747</b> (1) <b>537450</b> (2)
	(1) Ventilsitz/valve seat/siège de soupape/asiento de válvula/седло клапана 3,3 mm (2) Ventilsitz/valve seat/siège de soupape/asiento de válvula/седло клапана 3,8 mm					
[50]	Ø 8 mm					<b>KK-8H</b>
IN/EX [4] IN/EX [4] IN/EX [4] IN/EX [4]	14,05 x 8 x 48,0 14,06 x 8 x 52,2 14,07 x 8 x 50,0 14,29 x 8 x 52,2	B1 B1 B1 B1				<b>81-5326</b> <b>81-5320</b> <b>81-5314</b> <b>81-5317</b>
	491 mm					<b>50 006 220</b> (3)
	(3) Schalenhartguss/chilled cast iron/pièce moulée trempée en surface/fundición en coquilla/Отливка с отбеленным поверхностным слоем					

**67**
**83**

**D9B** 02.1996 → 12.2006 D (NA) 4 1905 cm<sup>3</sup> 2V 50-51 kW (68-69 PS) 23,5:1 88,00 mm  
**D9B (XUD9A)** D (NA) 4 1905 cm<sup>3</sup> 2V 47-52 kW (64-71 PS) 23 88,00 mm  
 93 648 7..

IN [2] EX [2] EX [2]	38,5 x 8 x 112,4 33,0 x 8 x 111,8 33,0 x 8 x 112,0	S - Cr - A - Cr - A - Cr -	- 45° - - - 45° - - - 45° - -	1 - III 1 - 1 -	  9 613 7362 80	<b>537746</b> <b>537747</b> (1) <b>537450</b> (2)
	(1) Ventilsitz/valve seat/siège de soupape/asiento de válvula/седло клапана 3,3 mm (2) Ventilsitz/valve seat/siège de soupape/asiento de válvula/седло клапана 3,8 mm					
[50]	Ø 8 mm					<b>KK-8H</b>
IN/EX [4] IN/EX [4] IN/EX [4] IN/EX [4]	14,05 x 8 x 48,0 14,06 x 8 x 52,2 14,07 x 8 x 50,0 14,29 x 8 x 52,2	B1 B1 B1 B1				<b>81-5326</b> <b>81-5320</b> <b>81-5314</b> <b>81-5317</b>
	491 mm					<b>50 006 220</b> (3)
	(3) Schalenhartguss/chilled cast iron/pièce moulée trempée en surface/fundición en coquilla/Отливка с отбеленным поверхностным слоем					

					Reference	Item No.			
<b>68</b>		<b>83</b>							
<b>DJY</b>	04.1998 → 04.2002	D (NA)	4	1905 cm <sup>3</sup>	2V	50 kW (68 PS)	23,5	88,00 mm	
93 648 7..									
	IN [2]	38,5 x 8 x 112,4	S - Cr -	- 45° -	-	1 - III		<b>537746</b>	
	EX [2]	33,0 x 8 x 111,8	A - Cr -	- 45° -	-	1 -		<b>537747</b>	(1)
(1) Ventilsitz/valve seat/siège de soupape/asiento de válvula/седло клапана 3,3 mm									
	[50]	Ø 8 mm						<b>KK-8H</b>	
	IN/EX [4]	14,05 x 8 x 48,0	B1					<b>81-5326</b>	
	IN/EX [4]	14,06 x 8 x 52,2	B1					<b>81-5320</b>	
	IN/EX [4]	14,07 x 8 x 50,0	B1					<b>81-5314</b>	
	IN/EX [4]	14,29 x 8 x 52,2	B1					<b>81-5317</b>	
		491 mm						<b>50 006 220</b>	(2)
(2) Schalenhartguss/chilled cast iron/pièce moulée trempée en surface/fundición en coquilla/Отливка с отбеленным поверхностным слоем									
<b>69</b>		<b>83</b>							
<b>198 A5.000</b>	09.2008 → 12.2014	D (A)	4	1956 cm <sup>3</sup>	4V	121 kW (165 PS)	16,5	90,40 mm	
<b>263 A1.000 Euro 5</b>	01.2010 →	D (LA)	4	1956 cm <sup>3</sup>	4V	99 kW (135 PS)	16,5	90,40 mm	
<b>844 A2.000</b>	09.2008 → 12.2014	D (A)	4	1956 cm <sup>3</sup>	4V	120 kW (163 PS)	16,5	90,40 mm	
<b>939 B5.000</b>	08.2011 →	D (LA)	4	1956 cm <sup>3</sup>	4V	100-125 kW (140-170 PS)		90,40 mm	
<b>940 A5.000 Euro 5</b>	08.2011 →	D (A)	4	1956 cm <sup>3</sup>	4V	103-125 kW (140-170 PS)	16,5	90,40 mm	
41 070 6..									
	IN [2]	27,8 x 5 x 114,4	S - Cr -	- 45° -	-	22 - III	55206431	<b>291114</b>	
	IN [2]	27,8 x 6 x 114,4	S - Cr -	- 45° -	-	22 - III	46802049 55195535 55202556	<b>291113</b>	
	EX [2]	24,2 x 5 x 114,3	A/S - Cr -	- 45° -	-	22 - III	55205183	<b>291116</b>	
	EX [2]	25,8 x 6 x 114,4	A/S - Cr -	- 45° -	VS -	22 - III	46787902 55202557	<b>291115</b>	
	[50]	Ø 5 mm						<b>MK-5H</b>	
	[50]	Ø 6 mm						<b>MK-6H</b>	
	IN/EX [4]	10,05 x 5 x 46,5	G1					<b>81-4220</b>	
	[8]	H 12 x 34 x 34					46475925	<b>50 006 438</b>	
<b>70</b>		<b>84</b>							
<b>131 B1.000</b>	03.1979 → 03.1982	B (NA)	4	1585 cm <sup>3</sup>	2V	72 kW (98 PS)	9	71,50 mm	
<b>131 C4.000</b>	01.1981 → 12.1984	B (NA)	4	1995 cm <sup>3</sup>	2V	83-85 kW (113-116 PS)	9	90,00 mm	
<b>132 B2.000</b>		B (NA)	4	1995 cm <sup>3</sup>	2V	83 kW (113 PS)	9:1	90,00 mm	
<b>132 D.000</b>	04.1981 → 12.1985	B (NA)	4	1585 cm <sup>3</sup>	2V	66-72 kW (90-98 PS)	9	71,50 mm	
<b>132 D1.000</b>	06.1978 → 12.1985	B (NA)	4	1995 cm <sup>3</sup>	2V	83 kW (113 PS)	9	90,00 mm	
<b>132 DB.2A.O</b>		B (NA)	4	1995 cm <sup>3</sup>	2V	82 kW (112 PS)	9:1	90,00 mm	
<b>138 AR.000</b>	05.1981 → 12.1987	B (NA)	4	1585 cm <sup>3</sup>	2V	66-77 kW (90-105 PS)	9,3	71,50 mm	
<b>138 AR1.000</b>		B (NA)	4	1995 cm <sup>3</sup>	2V	92 kW (125 PS)	9,4:1	90,00 mm	
<b>138 AR2.000</b>		B (NA)	4	1995 cm <sup>3</sup>	2V	96 kW (130 PS)	9,4:1	90,00 mm	
<b>149 A2.000</b>	10.1983 → 12.1990	B (NA)	4	1585 cm <sup>3</sup>	2V	74 kW (101 PS)	9,3	71,50 mm	
<b>149 A4.000</b>	01.1983 → 12.1990	B (NA)	4	1585 cm <sup>3</sup>	2V	74 kW (101 PS)	9,3	71,50 mm	
<b>154 A1.000</b>	12.1985 → 09.1992	B (NA)	4	1995 cm <sup>3</sup>	2V	66-74 kW (90-101 PS)	8	90,00 mm	
<b>159 A4.000</b>	03.1990 → 08.1996	B (NA)	4	1756 cm <sup>3</sup>	2V	74-81 kW (101-110 PS)	9,5	79,20 mm	
<b>159 A6.046</b>	03.1990 → 12.1998	B (NA)	4	1995 cm <sup>3</sup>	2V	76-85 kW (103-116 PS)	9,5	90,00 mm	
	[50]	Ø 8 mm						<b>RK-8</b>	
Fortsetzung nächste Seite / continued on next page / suite page suivante / continuación página próxima / Продолжение на следующей странице									

					Reference	Item No.	
	IN/EX [4] IN [4]	14,07 x 8 x 46,0 14,10 x 8 x 42,0	G1 G1		4 250 803 4 371 508	<b>81-17110</b> <b>81-1762</b>	
<b>71</b>		<b>84</b>					
<b>834 B.000</b>		03.1987 → 09.1992	B (NA)	4	1995 cm <sup>3</sup> 2V	88 kW (120 PS) 9,7	90,00 mm
	[50]	∅ 8 mm					<b>RK-8</b>
	IN [4]	14,10 x 8 x 42,0	G1		4 371 508	<b>81-1762</b>	
<b>72</b>		<b>84</b>					
<b>154 E1.000</b>		08.1992 → 12.1998	B (NA)	4	1995 cm <sup>3</sup> 4V	93-101 kW (126-137 PS) 10,3:1	90,00 mm
<b>160 A5.000</b>		11.1989 → 06.1992	B (NA)	4	1756 cm <sup>3</sup> 4V	100 kW (136 PS) 9,9	79,20 mm
<b>175 A1.000</b>		11.1993 → 08.1996	B (A)	4	1995 cm <sup>3</sup> 4V	140 kW (190 PS) 8	90,00 mm
<b>836 A3.000</b>		03.1993 → 08.1996	B (NA)	4	1995 cm <sup>3</sup> 4V	102 kW (139 PS) 10,5	90,00 mm
	[50]	∅ 7 mm					<b>RK-7H</b>
	IN/EX [4]	14,04 x 7 x 51,3	G1		7 616 998	<b>81-17112</b>	
<b>73</b>		<b>84</b>					
<b>M607 AA.18.0</b>			B	4	1756 cm <sup>3</sup> 4V	101 kW (138 PS) 9,9:1	79,20 mm
	IN/EX [4]	14,04 x 7 x 51,3	G1		7 616 998	<b>81-17112</b>	
<b>74</b>		<b>85</b>					
<b>RFN (EW10J4)</b>		05.2000 → 06.2011	B (NA)	4	1997 cm <sup>3</sup> 4V	100 kW (136 PS) 10,8	88,00 mm
40 309 6..							
	IN [2] EX [2]	33,3 x 6 x 106,2 29,0 x 6 x 103,6	S - - A/S - Cr -	- 45° - - 45° -	- - VS -	1 - III 1 - III	<b>531010</b> <b>531011</b>
	[50]						<b>KK-6H</b>
	IN [4] EX [4]	12,11 x 6 x 40,8 12,06 x 6 x 40,8	B1 G2				<b>81-5333</b> <b>81-5334</b>
	[8]	H 28,4 x 26 x 26					<b>50 006 480</b>
<b>75</b>		<b>85</b>					
<b>RHK (DW10UTED4)</b>		05.1999 → 12.2006	D (LA)	4	1997 cm <sup>3</sup> 4V	79-88 kW (107-120 PS) 17,5	88,00 mm
Euro 4							
99 700 6..							
	IN [2] EX [2]	30,0 x 6 x 105,0 25,0 x 6 x 105,0	S - Cr - A/S - Cr -	- 45° - - 45° -	- - VS -	22 - III 22 - III	<b>181104</b> <b>181105</b>
	[50]	∅ 6 mm					<b>MK-6H</b>
	IN/EX [4]	10,52 x 6 x 41,5	G1				<b>81-5330</b>
<b>76</b>		<b>85</b>					
<b>RHW (DW10ATED4)</b>		05.1999 → 12.2006	D (A)	4	1997 cm <sup>3</sup> 4V	80 kW (109 PS) 18	88,00 mm
Fortsetzung nächste Seite / continued on next page / suite page suivante / continuación página próxima / Продолжение на следующей странице							

**F**



					Reference	Item No.
IN [2] EX [2]	30,0 x 6 x 105,0 25,0 x 6 x 105,0	S - Cr - A/S - Cr -	- 45° - - - 45° - VS -	22 - III 22 - III	9627184380 9634437580	<b>181104</b> <b>181105</b>
[50]	∅ 6 mm					<b>MK-6H</b>
IN/EX [4]	10,52 x 6 x 41,5	G1				<b>81-5330</b>
	ES AS  (1) Schalenhartguss/chilled cast iron/pièce moulée trempée en surface/fundición en coquilla/Отливка с отбелнным поверхностным слоем					<b>50 007 010</b> (1) <b>50 007 012</b> (1)
[8]	H 12 x 34,6 x 34,6				46767972 9464396380 9632372480	<b>50 006 432</b>
[4]					9623446280 9640296380	<b>50 006 430</b>

**77** **85**

<b>DW10BTED4</b>	01.2007→	D (LA)	4	1997 cm <sup>3</sup>	4V	100 kW	(136 PS)	17,6	88,00 mm
<b>RHK Euro 4</b>	05.2006→	D (A)	4	1997 cm <sup>3</sup>	4V	88 kW	(120 PS)	17,5	88,00 mm
<b>RHM (DW10ATED4)</b>	05.1999→12.2006	D (A)	4	1997 cm <sup>3</sup>	4V	79-80 kW	(107-109 PS)	17,6:1	88,00 mm

99 700 6..

IN [2] EX [2]	30,0 x 6 x 105,0 25,0 x 6 x 105,0	S - Cr - A/S - Cr -	- 45° - - - 45° - VS -	22 - III 22 - III	9627184380 9634437580	<b>181104</b> <b>181105</b>
[50]	∅ 6 mm					<b>MK-6H</b>
IN/EX [4]	10,52 x 6 x 41,5	G1				<b>81-5330</b>
	ES AS  (1) Schalenhartguss/chilled cast iron/pièce moulée trempée en surface/fundición en coquilla/Отливка с отбелнным поверхностным слоем					<b>50 007 010</b> (1) <b>50 007 012</b> (1)
[8] [8] [8]	H 12 x 34,5 H 12 x 34,5 H 12 x 33,5 x 33,5				5801455560 9638075480	<b>50 006 169</b> <b>50 006 145</b> <b>50 006 435</b>
[4]						<b>50 006 096</b> (2)
	(2) mit Clip, with clip, avec clip, con clip, с брелоком-зажимом					

**78** **85**

<b>RHX</b>	10.1999→12.2006	D (A)	4	1997 cm <sup>3</sup>	2V	69 kW	(94 PS)	17,6	88,00 mm
------------	-----------------	-------	---	----------------------	----	-------	---------	------	----------

99 879 6..

IN [2] EX [2]	35,6 x 6 x 107,1 33,8 x 6 x 107,1	S - Cr - A/S - Cr -	- 45° - - - 45° - -	22 - III 22 - III	9624774280 9624774580	<b>531003</b> <b>531004</b>
IN/EX [4]	10,52 x 6 x 41,5	G1				<b>81-5330</b>
						<b>50 006 389</b> (1)
	(1) Schalenhartguss/chilled cast iron/pièce moulée trempée en surface/fundición en coquilla/Отливка с отбелнным поверхностным слоем					

Fortsetzung nächste Seite / continued on next page / suite page suivante / continuación página próxima / Продолжение на следующей странице

					Reference	Item No.
[8]	H 12 x 34,6 x 34,6				46767972 9464396380 9632372480	50 006 432
[8]	H 12 x 33,5 x 33,5				5801455560 9638075480	50 006 435

<b>79</b>		<b>85</b>				
<b>RHZ</b>	10.1999 → 12.2006	D (A)	4	1997 cm <sup>3</sup>	2V	80 kW (109 PS) 17,6 88,00 mm
99 879 6..						

IN [2]	35,6 x 6 x 107,1	S - Cr -	- 45° -	-	22 - III	9624774280	531003
EX [2]	33,8 x 6 x 107,1	A/S - Cr -	- 45° -	-	22 - III	9624774580	531004
IN/EX [4]	10,52 x 6 x 41,5	G1					81-5330
							50 006 389 (1)
(1) Schalenhartguss/chilled cast iron/pièce moulée trempée en surface/fundición en coquilla/Отливка с отбеленным поверхностным слоем							
[8]	H 12 x 34,6 x 34,6					46767972 9464396380 9632372480	50 006 432
[4]						9623446280 9640296380	50 006 430

<b>80</b>		<b>85</b>				
<b>4HW (DW12ATED4)</b>	08.2002 → 08.2006	D (A)	4	2179 cm <sup>3</sup>	4V	94 kW (128 PS) 18 96,00 mm
40 406 6..						

IN [2]	27,3 x 6 x 96,0	S - Cr -	- 45° -	-	22 - III		539050 <b>NEW</b>
IN [2]	30,0 x 6 x 105,0	S - Cr -	- 45° -	-	22 - III	9627184380	181104
EX [2]	24,7 x 6 x 95,0	RA/S- Cr -	- 45° -	VS -	22 - III		539051 <b>NEW</b>
EX [2]	25,0 x 6 x 105,0	A/S - Cr -	- 45° -	VS -	22 - III	9634437580	181105
[50]	Ø 6 mm						MK-6H
IN/EX [4]	10,52 x 6 x 41,5	G1					81-5330
	ES AS						50 007 088 <b>NEW</b> (1) 50 007 089 (1)
(1) Schalenhartguss/chilled cast iron/pièce moulée trempée en surface/fundición en coquilla/Отливка с отбеленным поверхностным слоем							
[8]	H 12 x 33,5 x 33,5					5801455560 9638075480	50 006 435
[4]							50 006 096 (2)
(2) mit Clip, with clip, avec clip, con clip, с брелоком-зажимом							

<b>81</b>		<b>85</b>				
<b>RHR</b>	05.2006 →	D (A)	4	1997 cm <sup>3</sup>	4V	100 kW (136 PS) 18 88,00 mm
99 700 6..						

IN [2]	30,0 x 6 x 105,0	S - Cr -	- 45° -	-	22 - III	9627184380	181104
EX [2]	25,0 x 6 x 105,0	A/S - Cr -	- 45° -	VS -	22 - III	9634437580	181105
[50]	Ø 6 mm						MK-6H
Fortsetzung nächste Seite / continued on next page / suite page suivante / continuación página próxima / Продолжение на следующей странице							

					Reference	Item No.
	IN/EX [4]	10,52 x 6 x 41,5	G1			<b>81-5330</b>
	ES AS					<b>50 007 010</b> <small>NEW</small> (1) <b>50 007 012</b> (1)
	(1) Schalenhartguss/chilled cast iron/pièce moulée trempée en surface/fundición en coquilla/Отливка с отбеленным поверхностным слоем					
	[8]	H 12 x 33,5 x 33,5			5801455560 9638075480	<b>50 006 435</b>
<b>82</b>		<b>85</b>				
<b>4HT (DW12BTED4)</b> 03.2008 → 06.2011 D (A) 4 2179 cm <sup>3</sup> 4V 125 kW (170 PS) 16,6 96,00 mm Euro 4 41 703 6..						
	IN [2] EX [2]	27,3 x 6 x 96,0 24,7 x 6 x 95,0	S - Cr - RA/S- Cr -	- 45° - - 45° - VS -	22 - III 22 - III	<b>539050</b> <small>NEW</small> <b>539051</b> <small>NEW</small>
	[50]	∅ 6 mm				<b>MK-6H</b>
	IN/EX [4]	10,52 x 6 x 41,5	G1			<b>81-5330</b>
	[8]	H 12 x 33			9659189980	<b>50 006 494</b>
<b>83</b>		<b>85</b>				
<b>4HP</b> 03.2008 → 06.2011 D (A) 4 2179 cm <sup>3</sup> 4V 120 kW (163 PS) 96,00 mm <b>4HR</b> 03.2008 → 06.2011 D (A) 4 2179 cm <sup>3</sup> 4V 120 kW (163 PS) 17,6:1 96,00 mm <b>4HX (DW12TED4)</b> D (LA) 4 2179 cm <sup>3</sup> 4V 94-100 kW (128-136 PS) 96,00 mm						
	IN [2] EX [2]	27,3 x 6 x 96,0 24,7 x 6 x 95,0	S - Cr - RA/S- Cr -	- 45° - - 45° - VS -	22 - III 22 - III	<b>539050</b> <small>NEW</small> <b>539051</b> <small>NEW</small>
	[50]	∅ 6 mm				<b>MK-6H</b>
<b>84</b>		<b>85</b>				
<b>RHH Euro 5</b> 07.2010 → D (A) 4 1997 cm <sup>3</sup> 4V 120 kW (163 PS) 16 88,00 mm						
	IN [2] EX [2]	27,2 x 6 x 104,5 25,0 x 6 x 105,0	S - Cr - A/S - Cr -	- 45° - Y - - 45° - VS -	22 - III 22 - III	<b>181117</b> <small>NEW</small> <b>181105</b>
	[50]	∅ 6 mm			9634437580	<b>MK-6H</b>
	IN/EX [4]	10,52 x 6 x 41,5	G1			<b>81-5330</b>
<b>85</b>		<b>86</b>				
<b>128 AS.000</b> 05.1973 → 12.1979 B (NA) 4 1290 cm <sup>3</sup> 2V 46-55 kW (63-75 PS) 9,2 55,50 mm						
	[50]	∅ 8 mm				<b>RK-8</b>
	IN/EX [4] IN [4]	14,07 x 8 x 46,0 14,10 x 8 x 42,0	G1 G1		4 250 803 4 371 508	<b>81-17110</b> <b>81-1762</b>
<b>86</b>		<b>86</b>				
<b>RGX (XU10J2CTE)</b> 06.1994 → 08.2002 B (A) 4 1998 cm <sup>3</sup> 2V 108 kW (147 PS) 8,5 86,00 mm						
Fortsetzung nächste Seite / continued on next page / suite page suivante / continuación página próxima / Продолжение на следующей странице						



					Reference	Item No.	
<b>90</b>		<b>86,4</b>					
<b>186 A3.000</b>	04.1999 → 06.2010	BG (NA)	4	1581 cm <sup>3</sup> 4V	70 kW (95 PS) 12,5	67,40 mm	
	IN [2]	30,3 x 7 x 102,5	S - Cr -	- 45° - -	9 - III	4 641 3806 4 646 2158 4 651 7325 4 676 1369 5 518 3592 5 519 2067	<b>171036</b>
	[50]	∅ 7 mm					<b>RK-7</b>
	IN/EX [4]	13,00 x 7 x 42,2	G1			4 372 331 4265699	<b>81-1755</b>
	IN [4]	13,03 x 7 x 42,5	G2			608 11 086 7 757 052	<b>81-17122</b>
	EX [4]	13,03 x 7 x 46,0	G2			608 11 089 7 779 402	<b>81-17123</b>
<b>91</b>		<b>86,4</b>					
<b>128 A3.000</b>	01.1981 → 09.1982	B (NA)	4	1301 cm <sup>3</sup> 2V	55 kW (75 PS) 9,1:1	55,50 mm	
<b>138 A1.000</b>	01.1978 → 08.1985	B (NA)	4	1301 cm <sup>3</sup> 2V	48 kW (65 PS) 9	55,50 mm	
<b>138 A2.000</b>	01.1978 → 12.1988	B (NA)	4	1498 cm <sup>3</sup> 2V	55-57 kW (75-78 PS) 9	63,90 mm	
<b>138 A3.000</b>	01.1981 → 09.1982	B (NA)	4	1301 cm <sup>3</sup> 2V	55 kW (75 PS) 9	55,50 mm	
<b>138 A4.000</b>	11.1978 → 12.1989	B (NA)	4	1498 cm <sup>3</sup> 2V	63 kW (86 PS) 9,2	63,90 mm	
<b>138 B2.000</b>	01.1983 → 07.1989	B (NA)	4	1302 cm <sup>3</sup> 2V	50-51 kW (68-69 PS) 9,1	55,50 mm	
<b>138 B3.000</b>	01.1983 → 12.1995	B (NA)	4	1498 cm <sup>3</sup> 2V	55-63 kW (75-86 PS) 9,2	63,90 mm	
<b>138 B3.048</b>	01.1983 → 07.1989	B (NA)	4	1498 cm <sup>3</sup> 2V	55-57 kW (75-78 PS) 9	63,90 mm	
<b>138 C2.048</b>	01.1978 → 12.1993	B (NA)	4	1498 cm <sup>3</sup> 2V	55 kW (75 PS) 9	63,90 mm	
<b>149 A5.000</b>	05.1985 → 12.1987	B (NA)	4	1498 cm <sup>3</sup> 2V	58 kW (79 PS) 9,2	63,90 mm	
<b>149 A7.000</b>	01.1978 → 08.1989	B (NA)	4	1302 cm <sup>3</sup> 2V	48 kW (65 PS) 9,6	55,50 mm	
<b>149 A7.003</b>		B (NA)	4	1301 cm <sup>3</sup> 2V	48-50 kW (65-68 PS) 9,2:1	55,50 mm	
<b>159 A3.000</b>	02.1983 → 09.2000	B (NA)	4	1581 cm <sup>3</sup> 2V	62-69 kW (84-94 PS) 9,2	67,40 mm	
<b>160 A2.000</b>	01.1988 → 10.1992	B (NA)	4	1581 cm <sup>3</sup> 2V	58-62 kW (79-84 PS) 9,2	67,40 mm	
<b>M202 AA.13.0</b>		B	4	1301 cm <sup>3</sup> 2V	55 kW (75 PS) 9,1:1	55,50 mm	
<b>M605 AA.15.000</b>		B	4	1498 cm <sup>3</sup> 2V	55 kW (75 PS) 9,2:1	63,90 mm	
	[50]	∅ 8 mm					<b>RK-8</b>
	IN/EX [4]	14,07 x 8 x 46,0	G1			4 250 803	<b>81-17110</b>
	IN [4]	14,10 x 8 x 42,0	G1			4 371 508	<b>81-1762</b>
<b>92</b>		<b>86,4</b>					
<b>176 A9.000</b>	01.1994 → 04.1997	B (NA)	4	1581 cm <sup>3</sup> 2V	65 kW (88 PS) 9,5	67,40 mm	
	IN [2]	39,5 x 8 x 108,5	S - Cr -	- 45° - -	1 - III	7 617 500	<b>17089</b>
	[50]	∅ 8 mm					<b>RK-8</b>
	IN/EX [4]	14,07 x 8 x 46,0	G1			4 250 803	<b>81-17110</b>
	IN [4]	14,10 x 8 x 42,0	G1			4 371 508	<b>81-1762</b>
<b>93</b>		<b>86,4</b>					
<b>182 A6.000</b>	10.1995 → 05.2005	B (NA)	4	1581 cm <sup>3</sup> 4V	66 kW (90 PS) 10,1	67,40 mm	
Fortsetzung nächste Seite / continued on next page / suite page suivante / continuación página próxima / Продолжение на следующей странице							



					Reference	Item No.
IN [2]	30,3 x 7 x 102,5	S - Cr -	- 45° - -	9 - III	4 641 3806 4 646 2158 4 651 7325 4 676 1369 5 518 3592 5 519 2067	<b>171036</b>
EX [2]	30,0 x 7 x 102,4	A/S - Cr -	- 45° - VS -	9 -	46 461 209	<b>171037</b>
EX [2]	30,0 x 7 x 102,8	A - Cr -	- 45° - -	9 -	4 641 3807 4 646 2159 4 676 1370 5 519 6738	<b>171043</b>
[50]	∅ 7 mm					<b>RK-7</b>
[50]	∅ 8 mm					<b>RK-8</b>
IN/EX [4]	13,00 x 7 x 42,2	G1			4 372 331 4265699	<b>81-1755</b>
[8]	H 33 x 24 x 24				46787055 73503122	<b>50 006 422</b>

**F**

<b>94</b>		<b>86,4</b>
<b>178 B3.000</b>	04.1996 → 12.2009	B (NA) 4 1581 cm <sup>3</sup> 4V 74-85 kW (100-116 PS) 10,15 67,40 mm
<b>182 A4.000</b>	02.1996 → 06.2010	B (NA) 4 1581 cm <sup>3</sup> 4V 76-85 kW (103-116 PS) 10,5 67,40 mm

IN [2]	30,3 x 7 x 102,5	S - Cr -	- 45° - -	9 - III	4 641 3806 4 646 2158 4 651 7325 4 676 1369 5 518 3592 5 519 2067	<b>171036</b>
EX [2]	30,0 x 7 x 102,4	A/S - Cr -	- 45° - VS -	9 -	46 461 209	<b>171037</b>
EX [2]	30,0 x 7 x 102,8	A - Cr -	- 45° - -	9 -	4 641 3807 4 646 2159 4 676 1370 5 519 6738	<b>171043</b>
[50]	∅ 7 mm					<b>RK-7</b>
[50]	∅ 8 mm					<b>RK-8</b>
IN/EX [4]	13,00 x 7 x 42,2	G1			4 372 331 4265699	<b>81-1755</b>
IN [4]	13,03 x 7 x 42,5	G2			608 11 086 7 757 052	<b>81-17122</b>
EX [4]	13,03 x 7 x 46,0	G2			608 11 089 7 779 402	<b>81-17123</b>
[8]	H 33 x 24 x 24				46787055 73503122	<b>50 006 422</b>

<b>95</b>		<b>86,4</b>
<b>178 C7.098</b>	07.1997 →	B (NA) 4 1581 cm <sup>3</sup> 4V 68-76 kW (92-103 PS) 10,5:1 67,40 mm
<b>178 D2.011</b>	06.1996 →	B (NA) 4 1581 cm <sup>3</sup> 4V 60-78 kW (82-106 PS) 10,5 67,40 mm
<b>182 A4.027</b>		B 4 1581 cm <sup>3</sup> 4V 76 kW (103 PS) 10,15:1 67,40 mm

[8]	H 33 x 24 x 24				46787055 73503122	<b>50 006 422</b>
-----	----------------	--	--	--	----------------------	-------------------

<b>96</b>		<b>87</b>
<b>XFW</b>	08.2002 → 06.2011	B (NA) 6 2946 cm <sup>3</sup> 4V 150-152 kW (204-207 PS) 10,9 82,60 mm

IN [2]	35,0 x 6 x 108,5	S - -	- 45° - -	1 - III		<b>539022</b>
EX [2]	30,5 x 6 x 107,0	A/S - Cr -	- 45° - VS -	1 - III		<b>539023</b>
[50]	∅ 6 mm					<b>LK-6H</b>

					Reference	Item No.
<b>97</b>	<b>88</b>					
<b>834 G.000</b>	06.1993 → 08.1996	B	(NA)	6	2492 cm <sup>3</sup> 2V	119 kW (162 PS) 10:1 68,30 mm
	EX [6]	14,07 x 9 x 42,5	G1			<b>81-5609</b>
<b>98</b>	<b>88</b>					
<b>8144.65</b>	03.1978 → 03.1987	D	(NA)	4	1995 cm <sup>3</sup> 2V	44 kW (60 PS) 22,1 82,00 mm
	IN [2]	41,0 x 8 x 120,8	S - Cr -	- 30° -	- 9 - III	47 57 358 504069200 7 301 820 <b>171120</b>
	EX [2]	36,0 x 8 x 122,0	A/S - Cr -	- 45° -	- 9 - III	99432837 <b>171055</b>
	[50] [50]	∅ 8 mm ∅ 8 mm				<b>RK-8</b> <b>RK-8H</b>
	IN/EX [4] IN/EX [4] IN/EX [4]	13,02 x 8.02 x 56,0 13,07 x 8.02 x 56,0 13,07 x 8.02 x 60,0	G1 G1 G1			4 749 395 4 749 397 4 726 483 4 733 258 <b>81-17116</b> <b>81-17115</b> <b>81-17114</b> (1)
	IN/EX [4]	13,12 x 8 x 56,0	G1			4 749 398 <b>81-5611</b>
	(1)	ohne Ventilschaftabdichtung/without valve stem gasket/sans joint de tige de soupape/sin junta de vástago de válvula/без уплотнения стержня клапана				
	[8]	M 44 x 32				4733350 <b>50 006 180</b>
<b>99</b>	<b>88</b>					
<b>F1AE0481C Euro 3</b>	04.2002 →	D	(A)	4	2286 cm <sup>3</sup> 4V	81 kW (110 PS) 18,5 94,00 mm
	40 285 6..					
	IN [2]	30,0 x 6 x 120,4	S - Cr -	- 45° -	- 22 - III	500362855 504069199 <b>171113</b>
	EX [2]	30,0 x 6 x 120,4	A/S - Cr -	- 45° -	- 22 - III	500362856 504378070 <b>171114</b>
	[8]	H 12 x 33,5 x 33,5				5801455560 9638075480 <b>50 006 435</b>
<b>100</b>	<b>88</b>					
<b>F1AE0481D Euro 4</b>	07.2006 →	D	(A)	4	2287 cm <sup>3</sup> 4V	88 kW (120 PS) 19 94,00 mm
<b>F1AE0481N Euro 5</b>	07.2006 →	D	(A)	4	2287 cm <sup>3</sup> 4V	96 kW (131 PS) 19 94,00 mm
<b>F1AE3481D</b>	07.2006 →	D	(A)	4	2287 cm <sup>3</sup> 4V	96 kW (131 PS) 16,2 94,00 mm
	40 286 6.., 41 707 6..					
	IN [2]	30,0 x 6 x 120,4	S - Cr -	- 45° -	- 22 - III	500362855 504069199 <b>171113</b>
	EX [2]	30,0 x 6 x 120,4	A/S - Cr -	- 45° -	- 22 - III	500362856 504378070 <b>171114</b>
	[8]	H 12 x 33,5 x 33,5				5801455560 9638075480 <b>50 006 435</b>
	[4]					504380370 <b>50 007 629</b> (1)
	(1)	Hydr. tappet - 50006435				
<b>101</b>	<b>88</b>					
<b>8144.65</b>	<b>300</b>	D		4	1995 cm <sup>3</sup> 2V	44 kW (60 PS) 22:1 82,00 mm
Fortsetzung nächste Seite / continued on next page / suite page suivante / continuación página próxima / Продолжение на следующей странице						

					Reference	Item No.
IN [2]	41,0 x 8 x 120,8	S - Cr -	- 30° - -	9 - III	47 57 358 504069200 7 301 820	<b>171120</b>
EX [2]	32,9 x 8 x 122,0	A/S - Cr -	- 45° - -	1 - III	4 733 349	<b>17032</b>
EX [2]	36,0 x 8 x 122,0	A/S - Cr -	- 45° - -	9 - III	99432837	<b>171055</b>
[50]	Ø 8 mm					<b>RK-8</b>
[50]	Ø 8 mm					<b>RK-8H</b>
IN/EX [4]	13,02 x 8.02 x 56,0	G1			4 749 395	<b>81-17116</b>
IN/EX [4]	13,07 x 8.02 x 56,0	G1			4 749 397	<b>81-17115</b>
IN/EX [4]	13,07 x 8.02 x 60,0	G1			4 726 483	<b>81-17114</b> (1)
IN/EX [4]	13,12 x 8 x 56,0	G1			4 733 258 4 749 398	<b>81-5611</b>
(1) ohne Ventilschaftabdichtung/without valve stem gasket/sans joint de tige de soupape/sin junta de vástago de válvula/без уплотнения стержня клапана						
[8]	M 44 x 32				4733350	<b>50 006 180</b>

**102** **91,48**

**4.203** 01.1971 → D (NA) 4 3335 cm<sup>3</sup> 2V 44 kW (60 PS) 17,4:1 126,90 mm  
91 130 6.., 91 130 7..

IN [2]	39,0 x 7,9 x 114,3	S - -	- 45° - -	1 - III		<b>105-02076</b>
EX [2]	33,4 x 7,9 x 114,3	S - -	- 45° - -	1 - III		<b>105-02077</b>
EX [2]	33,4 x 7,9 x 114,3 M + 1	S - -	- 45° - -	1 - III		<b>105-35469</b>
IN/EX [4]	12,74 x 8 x 62,0	G1				<b>81-85005</b>

**103** **91,48**

**D 3.152** 01.1971 → D 3 2503 cm<sup>3</sup> 2V 35 kW (47 PS) 17,4:1 126,90 mm  
**D 4.203** 01.1984 → D 4 3335 cm<sup>3</sup> 2V 40 kW (54 PS) 18,6:1 126,90 mm  
92 772 6.., 93 961 7..

IN [2]	39,0 x 7,9 x 114,3	S - -	- 45° - -	1 - III		<b>105-03363</b>
IN [2]	39,0 x 7,9 x 114,3 M + 0.8	S - -	- 45° - -	1 - III		<b>105-35470</b>
EX [2]	33,4 x 7,9 x 114,3	S - -	- 45° - -	1 - III		<b>105-03364</b>
EX [2]	33,4 x 7,9 x 114,3 M + 0.8	S - -	- 45° - -	1 - III		<b>105-35471</b>
IN/EX [4]	12,74 x 8 x 62,0	G1				<b>81-85005</b>

**104** **93**

<b>8140.07</b>	<b>2530, 2731</b>					
		D	4	2499 cm <sup>3</sup>	2V	55 kW (75 PS) 18,5:1 92,00 mm
<b>8140.07 Euro 1</b>	<b>3731</b>					
		D (LA)	4	2499 cm <sup>3</sup>	2V	53 kW (72 PS) 19:1 92,00 mm
<b>8140.21</b>	<b>235</b>					
	06.1987 → 12.1989	D (A)	4	2445 cm <sup>3</sup>	2V	68 kW (92 PS) 18:1 90,00 mm
<b>8140.61</b>	<b>201, 202, 203, 207, 208, 212, 216, 217, 235</b>					
		D	4	2445 cm <sup>3</sup>	2V	53 kW (72 PS) 21:1 90,00 mm
<b>8140.61</b>	<b>204</b>					
	09.1986 →	D (NA)	4	2445 cm <sup>3</sup>	2V	53-55 kW (72-75 PS) 90,00 mm
<b>8140.67 Euro 2</b>						
	03.1994 → 04.2002	D (NA)	4	2500 cm <sup>3</sup>	2V	55-62 kW (75-84 PS) 22 92,00 mm
<b>8144.61</b>						
	06.1978 → 08.1990	D (NA)	4	2428 cm <sup>3</sup>	2V	53-55 kW (72-75 PS) 21 89,40 mm
<b>8144.61</b>	<b>200</b>					
	06.1974 → 10.1989	D (NA)	4	2445 cm <sup>3</sup>	2V	53 kW (72 PS) 22 90,00 mm

Fortsetzung nächste Seite / continued on next page / suite page suivante / continuación página próxima / Продолжение на следующей странице

					<b>Reference</b>	<b>Item No.</b>
IN [2]	41,0 x 8 x 120,8	S - Cr -	- 30° - -	9 - III	47 57 358 504069200 7 301 820	<b>171120</b>
EX [2]	34,5 x 8 x 122,0	A/S - Cr -	- 45° - -	9 - III	4 826 033 4826033 7 301 821 7301821	<b>17063</b>
[50]	∅ 8 mm					<b>RK-8</b>
[50]	∅ 8 mm					<b>RK-8H</b>
IN/EX [4]	13,02 x 8.02 x 56,0	G1			4 749 395	<b>81-17116</b>
IN/EX [4]	13,07 x 8.02 x 56,0	G1			4 749 397	<b>81-17115</b>
IN/EX [4]	13,07 x 8.02 x 60,0	G1			4 726 483	<b>81-17114</b> (1)
IN/EX [4]	13,12 x 8 x 56,0	G1			4 733 258 4 749 398	<b>81-5611</b>
(1) ohne Ventilschaftabdichtung/without valve stem gasket/sans joint de tige de soupape/sin junta de vástago de válvula/без уплотнения стержня клапана						

**105**

**8142.61**

 06.1979 → 10.1986 D (NA) 4 2445 cm<sup>3</sup> 2V 53 kW (72 PS) 21:1 90,00 mm

EX [2]	32,9 x 8 x 122,0	A/S - Cr -	- 45° - -	1 - III	4 733 349	<b>17032</b>
[50]	∅ 8 mm					<b>RK-8</b>

**106**

**B 25.637**

 08.1980 → 07.1982 D (NA) 4 2498 cm<sup>3</sup> 2V 51 kW (69 PS) 22,25 92,00 mm

93 844 7..

[50]	∅ 8 mm					<b>MK-8H</b>
[50]	∅ 9 mm					<b>MK-9H</b>
IN [4]	13,07 x 8 x 54,0	G1				<b>81-1526</b>

**107**

**8144.61**
**500.81**  
 07.1983 → 08.1985 D (NA) 4 2445 cm<sup>3</sup> 2V 66 kW (90 PS) 22 90,00 mm

IN [2]	41,0 x 8 x 120,8	S - Cr -	- 30° - -	9 - III	47 57 358 504069200 7 301 820	<b>171120</b>
EX [2]	32,9 x 8 x 122,0	A/S - Cr -	- 45° - -	1 - III	4 733 349	<b>17032</b>
[50]	∅ 8 mm					<b>RK-8</b>
[50]	∅ 8 mm					<b>RK-8H</b>
IN/EX [4]	13,02 x 8.02 x 56,0	G1			4 749 395	<b>81-17116</b>
IN/EX [4]	13,07 x 8.02 x 56,0	G1			4 749 397	<b>81-17115</b>
IN/EX [4]	13,07 x 8.02 x 60,0	G1			4 726 483	<b>81-17114</b> (1)
IN/EX [4]	13,12 x 8 x 56,0	G1			4 733 258 4 749 398	<b>81-5611</b>
(1) ohne Ventilschaftabdichtung/without valve stem gasket/sans joint de tige de soupape/sin junta de vástago de válvula/без уплотнения стержня клапана						

					Reference	Item No.		
<b>108</b>		<b>93</b>						
<b>8140.27 Euro 1</b>	<b>3700</b>							
	01.1993 →	D (LA)	4	2499 cm <sup>3</sup>	2V	77 kW (104 PS) 18,5:1 92,00 mm		
<b>8140.27</b>	<b>2560, 2590</b>	D (A)	4	2499 cm <sup>3</sup>	2V	69 kW (94 PS) 92,00 mm		
<b>8140.97</b>	<b>2783</b>	D (LA)	4	2499 cm <sup>3</sup>	2V	66-69 kW (90-94 PS) 22,5:1 92,00 mm		
<b>8144.81</b>	<b>2000</b>	D (A)	4	2445 cm <sup>3</sup>	2V	66-74 kW (90-101 PS) 22:1 90,00 mm		
<b>8144.91</b>	<b>2000, 2200</b>	D (LA)	4	2445 cm <sup>3</sup>	2V	74 kW (100-101 PS) 90,00 mm		
<b>8144.97 S</b>	12.1985 →	D (LA)	4	2445 cm <sup>3</sup>	2V	77 kW (105 PS) 21 92,00 mm		
	12.1991 → 08.1996	D (A)	4	2500 cm <sup>3</sup>	2V	77 kW (105 PS) 21 92,00 mm		
	IN [2]	41,0 x 8 x 120,8	S - Cr -	- 30° -	-	9 - III 47 57 358 504069200 7 301 820 99432837	<b>171120</b>	
	EX [2]	36,0 x 8 x 122,0	A/S - Cr -	- 45° -	-	9 - III	<b>171055</b>	
	[50]	∅ 8 mm					<b>RK-8</b>	
	[50]	∅ 8 mm					<b>RK-8H</b>	
	IN/EX [4]	13,02 x 8.02 x 56,0	G1			4 749 395	<b>81-17116</b>	
	IN/EX [4]	13,07 x 8.02 x 56,0	G1			4 749 397	<b>81-17115</b>	
	IN/EX [4]	13,07 x 8.02 x 60,0	G1			4 726 483	<b>81-17114</b> (1)	
						4 733 258		
	IN/EX [4]	13,12 x 8 x 56,0	G1			4 749 398	<b>81-5611</b>	
	(1)	ohne Ventilschaftabdichtung/without valve stem gasket/sans joint de tige de soupape/sin junta de vástago de válvula/без уплотнения стержня клапана						
	[8]	M 44 x 32				4733350	<b>50 006 180</b>	
<b>109</b>		<b>93</b>						
<b>8140.27</b>	<b>2350</b>							
		D	4	2445 cm <sup>3</sup>	2V	68-71 kW (92-97 PS) 90,00 mm		
<b>8140.27 Euro 1</b>	<b>2585</b>	D (A)	4	2499 cm <sup>3</sup>	2V	76-78 kW (103-106 PS) 18,5:1 92,00 mm		
	02.1993 →	D (A)	4	2499 cm <sup>3</sup>	2V	76-78 kW (103-106 PS) 18,5:1 92,00 mm		
<b>8140.27</b>	<b>200, 2100, 2101, 2512</b>	D (A)	4		2V	69-76 kW (94-103 PS) 92,00 mm		
<b>8140.27S Euro 1</b>	<b>3700, 3710, 3800</b>	D (A)	4	2499 cm <sup>3</sup>	2V	77 kW (104-105 PS) 18,5:1 92,00 mm		
<b>8140.27S</b>	<b>2785</b>	D (A)	4	2499 cm <sup>3</sup>	2V	76 kW (103 PS) 18:1 92,00 mm		
<b>8140.47 Euro 1</b>	<b>2580</b>	D (A)	4	2499 cm <sup>3</sup>	2V	76 kW (103 PS) 92,00 mm		
<b>8140.47 Euro 1</b>	<b>2585, 2590, 2731, 3700</b>	D (A)	4	2499 cm <sup>3</sup>	2V	76 kW (103 PS) 92,00 mm		
	08.1994 →	D (LA)	4	2499 cm <sup>3</sup>	2V	85 kW (116 PS) 18,5:1 92,00 mm		
<b>8140.47S Euro 1</b>	<b>2785</b>	D (LA)	4	2499 cm <sup>3</sup>	2V	85 kW (115 PS) 18,5:1 92,00 mm		
<b>8144.21</b>	<b>220</b>	D (A)	4	2445 cm <sup>3</sup>	2V	68 kW (92 PS) 18 90,00 mm		
	01.1986 → 02.1991	D (A)	4	2445 cm <sup>3</sup>	2V	68 kW (92 PS) 18 90,00 mm		
<b>8144.67</b>	<b>200, 2500</b>	D	4	2499 cm <sup>3</sup>	2V	55 kW (75 PS) 22:1 92,00 mm		
<b>8144.97</b>		D (A)	4	2499 cm <sup>3</sup>	2V	85 kW (115 PS) 22,5:1 92,00 mm		
	05.1989 → 08.1996	D (A)	4	2499 cm <sup>3</sup>	2V	85 kW (115 PS) 22,5:1 92,00 mm		
<b>8144.97 Y</b>		D (A)	4	2500 cm <sup>3</sup>	2V	85 kW (115 PS) 22,5 92,00 mm		
	05.1989 → 08.1996	D (A)	4	2500 cm <sup>3</sup>	2V	85 kW (115 PS) 22,5 92,00 mm		

Fortsetzung nächste Seite / continued on next page / suite page suivante / continuación página próxima / Продолжение на следующей странице



					Reference	Item No.
	IN [2] 41,0 x 8 x 120,8	S - Cr -	- 30° - -	9 - III	47 57 358 504069200 7 301 820	<b>171120</b>
	EX [2] 34,5 x 8 x 122,0	A/S - Cr -	- 45° - -	9 - III	4 826 033 4826033 7 301 821 7301821	<b>17063</b>
	EX [2] 36,0 x 8 x 122,0	A/S - Cr -	- 45° - -	9 - III	99432837	<b>171055</b>
	[50] [50]	∅ 8 mm ∅ 8 mm				<b>RK-8</b> <b>RK-8H</b>
	IN/EX [4] IN/EX [4] IN/EX [4] IN/EX [4]	G1 G1 G1 G1			4 749 395 4 749 397 4 726 483 4 733 258 4 749 398	<b>81-17116</b> <b>81-17115</b> <b>81-17114</b> (1) <b>81-5611</b>
	(1) ohne Ventilschaftabdichtung/without valve stem gasket/sans joint de tige de soupape/sin junta de vástago de válvula/без уплотнения стержня клапана					
	[8] M 44 x 32				4733350	<b>50 006 180</b>
<b>110</b>	<b>93</b>					
<b>8140.67</b>	<b>2560</b>	D	4	2445 cm <sup>3</sup> 2V	55 kW (75 PS) 21:1	90,00 mm
<b>8140.67</b>	<b>2200, 2250, 2552, 2620, 2629, 2630, 2639</b>					
	10.1995 →	D	4	2499 cm <sup>3</sup> 2V	55-62 kW (75-84 PS)	92,00 mm
<b>8140.67</b>	<b>2700</b>					
	03.1993 →	D (NA)	4	2499 cm <sup>3</sup> 2V	62 kW (85 PS) 22:1	92,00 mm
94 576 7..						
	[50] [50]	∅ 8 mm ∅ 8 mm				<b>RK-8</b> <b>RK-8H</b>
	IN/EX [4] 13,07 x 8.02 x 60,0	G1			4 726 483 4 733 258	<b>81-17114</b> (1)
	(1) ohne Ventilschaftabdichtung/without valve stem gasket/sans joint de tige de soupape/sin junta de vástago de válvula/без уплотнения стержня клапана					
					98427674	<b>50 007 054</b> <small>NEW</small>
<b>111</b>	<b>93</b>					
<b>8140.07 Euro 1</b>	<b>3700</b>					
	10.1993 →	D (NA)	4	2499 cm <sup>3</sup> 2V	53 kW (72 PS) 19:1	92,00 mm
<b>8140.61</b>	<b>303</b>					
		D	4	2445 cm <sup>3</sup> 2V	53 kW (72 PS) 21:1	90,00 mm
	IN [2] 41,0 x 8 x 120,8	S - Cr -	- 30° - -	9 - III	47 57 358 504069200 7 301 820	<b>171120</b>
	EX [2] 34,5 x 8 x 122,0	A/S - Cr -	- 45° - -	9 - III	4 826 033 4826033 7 301 821 7301821	<b>17063</b>
	[50] [50]	∅ 8 mm ∅ 8 mm				<b>RK-8</b> <b>RK-8H</b>
	IN/EX [4] IN/EX [4] IN/EX [4] IN/EX [4]	G1 G1 G1 G1			4 749 395 4 749 397 4 726 483 4 733 258 4 749 398	<b>81-17116</b> <b>81-17115</b> <b>81-17114</b> (1) <b>81-5611</b>
	(1) ohne Ventilschaftabdichtung/without valve stem gasket/sans joint de tige de soupape/sin junta de vástago de válvula/без уплотнения стержня клапана					

Fortsetzung nächste Seite / continued on next page / suite page suivante / continuación página próxima / Продолжение на следующей странице

						<b>Reference</b>	<b>Item No.</b>	
(1)	ohne Ventilschaftabdichtung/without valve stem gasket/sans joint de tige de soupape/sin junta de vástago de válvula/без уплотнения стержня клапана							
[8]	M 44 x 32					4733350	<b>50 006 180</b>	
<b>112</b>	<b>93</b>							
<b>8140.47 Euro 1</b>	<b>2530</b>	D (LA)	4	2499 cm <sup>3</sup>	2V	85 kW (116 PS)	18,5:1 92,00 mm	
<b>8140.47 Euro 1</b>		03.1994 → 04.2002	D (A)	4	2500 cm <sup>3</sup>	2V 80-85 kW (109-116 PS)	18,5 92,00 mm	
<b>8140.47R Euro 1</b>		03.1994 → 04.2002	D (A)	4	2500 cm <sup>3</sup>	2V 80 kW (110 PS)	18,5 92,00 mm	
IN [2]	41,0 x 8 x 120,8	S - Cr -		- 30° -	-	9 - III	47 57 358 504069200 7 301 820	<b>171120</b>
EX [2]	34,5 x 8 x 122,0	A/S - Cr -		- 45° -	-	9 - III	4 826 033 4826033 7 301 821 7301821	<b>17063</b>
EX [2]	36,0 x 8 x 122,0	A/S - Cr -		- 45° -	-	9 - III	99432837	<b>171055</b>
[50]	Ø 8 mm						<b>RK-8</b>	
[50]	Ø 8 mm						<b>RK-8H</b>	
IN/EX [4]	13,02 x 8.02 x 56,0	G1					4 749 395	<b>81-17116</b>
IN/EX [4]	13,07 x 8.02 x 56,0	G1					4 749 397	<b>81-17115</b>
IN/EX [4]	13,07 x 8.02 x 60,0	G1					4 726 483 4 733 258	<b>81-17114</b> (1)
IN/EX [4]	13,12 x 8 x 56,0	G1					4 749 398	<b>81-5611</b>
(1)	ohne Ventilschaftabdichtung/without valve stem gasket/sans joint de tige de soupape/sin junta de vástago de válvula/без уплотнения стержня клапана							
							98427674	<b>50 007 054</b>
[8]	M 44 x 32						4733350	<b>50 006 180</b>
<b>113</b>	<b>93</b>							
<b>8140.67</b>	<b>2100</b>	D (A)	4	2499 cm <sup>3</sup>	2V	70 kW (95 PS)	18:1 92,00 mm	
IN [2]	41,0 x 8 x 120,8	S - Cr -		- 30° -	-	9 - III	47 57 358 504069200 7 301 820	<b>171120</b>
EX [2]	34,5 x 8 x 122,0	A/S - Cr -		- 45° -	-	9 - III	4 826 033 4826033 7 301 821 7301821	<b>17063</b>
[50]	Ø 8 mm							<b>RK-8</b>
[50]	Ø 8 mm							<b>RK-8H</b>
IN/EX [4]	13,02 x 8.02 x 56,0	G1					4 749 395	<b>81-17116</b>
IN/EX [4]	13,07 x 8.02 x 56,0	G1					4 749 397	<b>81-17115</b>
IN/EX [4]	13,07 x 8.02 x 60,0	G1					4 726 483 4 733 258	<b>81-17114</b> (1)
IN/EX [4]	13,12 x 8 x 56,0	G1					4 749 398	<b>81-5611</b>
(1)	ohne Ventilschaftabdichtung/without valve stem gasket/sans joint de tige de soupape/sin junta de vástago de válvula/без уплотнения стержня клапана							
							98427674	<b>50 007 054</b>

					Reference	Item No.
<b>114</b> <b>93</b>						
<b>8144.97</b>	<b>2200</b>	D (LA) 4	2499 cm <sup>3</sup> 2V	86-87 kW (117-118 PS)	22,5:1	92,00 mm
IN [2]	41,0 x 8 x 120,8	S - Cr -	- 30° - -	9 - III	47 57 358 504069200 7 301 820	<b>171120</b>
[50]	∅ 8 mm					<b>RK-8</b>
[50]	∅ 8 mm					<b>RK-8H</b>
IN/EX [4]	13,02 x 8.02 x 56,0	G1			4 749 395	<b>81-17116</b>
IN/EX [4]	13,07 x 8.02 x 56,0	G1			4 749 397	<b>81-17115</b>
IN/EX [4]	13,07 x 8.02 x 60,0	G1			4 726 483	<b>81-17114</b> (1)
IN/EX [4]	13,12 x 8 x 56,0	G1			4 733 258 4 749 398	<b>81-5611</b>
(1) ohne Ventilschaftabdichtung/without valve stem gasket/sans joint de tige de soupape/sin junta de vástago de válvula/без уплотнения стержня клапана						
<b>115</b> <b>94,4</b>						
<b>8140.23 Euro 2</b>	<b>3761, 3861</b>	D (LA) 4	2798 cm <sup>3</sup> 2V	76 kW (103 PS)	18,5:1	100,00 mm
<b>8140.23 Euro 2</b>	<b>3700</b>	D (A) 4	2798 cm <sup>3</sup> 2V	76 kW (103 PS)	18,5:1	100,00 mm
<b>8140.43 Euro 3</b>	<b>2800</b>	D (LA) 4	2798 cm <sup>3</sup> 2V	90 kW (122 PS)		100,00 mm
<b>8140.43 Euro 2</b>	<b>2200, 2210, 2609, 2620, 2629, 2639, 3700, 3780, 3900</b>	D (LA) 4	2V	84-90 kW (114-122 PS)		100,00 mm
<b>8140.43 Euro 2</b>	10.1997 → 07.2006	D (A) 4	2800 cm <sup>3</sup> 2V	90 kW (122 PS)	18,5	100,00 mm
<b>8140.43C Euro 2</b>	<b>2588, 4031</b>	D (LA) 4	2798 cm <sup>3</sup> 2V	78 kW (106 PS)		100,00 mm
<b>8140.43K Euro 3</b>	<b>2585</b>	D (LA) 4	2798 cm <sup>3</sup> 2V	103 kW (140 PS)	18,5:1	100,00 mm
<b>8140.43L Euro 2</b>	<b>4000</b>	D (LA) 4	2798 cm <sup>3</sup> 2V	92 kW (125 PS)	18,5:1	100,00 mm
<b>8140.43N Euro 3</b>	04.2004 →	D (A) 4	2800 cm <sup>3</sup> 2V	107 kW (146 PS)	18,5	100,00 mm
<b>8140.43S Euro 3</b>	11.2000 →	D (A) 4	2798 cm <sup>3</sup> 2V	93-103 kW (127-140 PS)	18,5	100,00 mm
<b>8140.43S Euro 3</b>	<b>2585</b>	D (LA) 4	2798 cm <sup>3</sup> 2V	92 kW (125 PS)	18,5:1	100,00 mm
<b>8140.63 Euro 3</b>	<b>4020, 4030</b>	D (LA) 4	2798 cm <sup>3</sup> 2V	62 kW (85 PS)	18,5	100,00 mm
<b>8140.63 Euro 2</b>	<b>4000</b>	D (NA) 4	2V	62-64 kW (84-87 PS)		100,00 mm
<b>8140.63</b>	<b>2800</b>	D (LA) 4	2798 cm <sup>3</sup> 2V	64 kW (87 PS)	18,5:1	100,00 mm
<b>8140.63 Euro 2</b>	<b>2200, 2586, 3700, 3711, 3713, 3721, 3723</b>	D (LA) 4	2798 cm <sup>3</sup> 2V	62 kW (85 PS)	21,7:1	100,00 mm
94 701 6..., 94 726 6..						
IN [2]	41,0 x 8 x 120,8	S - Cr -	- 30° - -	9 - III	47 57 358 504069200 7 301 820	<b>171120</b>
EX [2]	36,0 x 8 x 122,0	A/S - Cr -	- 45° - -	9 - III	99432837	<b>171055</b>
[50]	∅ 8 mm					<b>RK-8</b>
[50]	∅ 8 mm					<b>RK-8H</b>
IN/EX [4]	13,02 x 8.02 x 56,0	G1			4 749 395	<b>81-17116</b>
IN/EX [4]	13,07 x 8.02 x 56,0	G1			4 749 397	<b>81-17115</b>
IN/EX [4]	13,07 x 8.02 x 60,0	G1			4 726 483	<b>81-17114</b> (1)
IN/EX [4]	13,12 x 8 x 56,0	G1			4 733 258 4 749 398	<b>81-5611</b>
Fortsetzung nächste Seite / continued on next page / suite page suivante / continuación página próxima / Продолжение на следующей странице						

					Reference	Item No.	
(1)	ohne Ventilschaftabdichtung/without valve stem gasket/sans joint de tige de soupape/sin junta de vástago de válvula/без уплотнения стержня клапана						
[8]	M 44 x 32				4733350	<b>50 006 180</b>	
<b>116</b>	<b>94,4</b>						
<b>8140.23 Euro 2</b>	<b>2585</b>	D (A)	4	2798 cm <sup>3</sup>	2V	76-78 kW (103-106 PS) 18,5:1 100,00 mm	
<b>8140.43N Euro 3</b>	<b>4420</b>	D (LA)	4	2798 cm <sup>3</sup>	2V	108 kW (146 PS) 18,5:1 100,00 mm	
94 701 6..., 94 726 6...							
IN [2]	41,0 x 8 x 120,8	S - Cr -	- 30° -	-	9 - III	47 57 358 504069200 7 301 820 <b>171120</b>	
EX [2]	36,0 x 8 x 122,0	A/S - Cr -	- 45° -	-	9 - III	99432837 <b>171055</b>	
[50]	∅ 8 mm					<b>RK-8</b>	
[50]	∅ 8 mm					<b>RK-8H</b>	
IN/EX [4]	13,02 x 8.02 x 56,0	G1				4 749 395 <b>81-17116</b>	
IN/EX [4]	13,07 x 8.02 x 56,0	G1				4 749 397 <b>81-17115</b>	
IN/EX [4]	13,12 x 8 x 56,0	G1				4 749 398 <b>81-5611</b>	
<b>117</b>	<b>94,4</b>						
<b>8140.23 Euro 2</b>	<b>3900</b>	D (LA)	4	2798 cm <sup>3</sup>	2V	76 kW (103 PS) 18,5:1 100,00 mm	
94 701 6...							
IN [2]	41,0 x 8 x 120,8	S - Cr -	- 30° -	-	9 - III	47 57 358 504069200 7 301 820 <b>171120</b>	
EX [2]	36,0 x 8 x 122,0	A/S - Cr -	- 45° -	-	9 - III	99432837 <b>171055</b>	
[50]	∅ 8 mm					<b>RK-8</b>	
[50]	∅ 8 mm					<b>RK-8H</b>	
IN/EX [4]	13,02 x 8.02 x 56,0	G1				4 749 395 <b>81-17116</b>	
IN/EX [4]	13,07 x 8.02 x 56,0	G1				4 749 397 <b>81-17115</b>	
IN/EX [4]	13,07 x 8.02 x 60,0	G1				4 726 483 4 733 258 <b>81-17114 (1)</b>	
IN/EX [4]	13,12 x 8 x 56,0	G1				4 749 398 <b>81-5611</b>	
(1)	ohne Ventilschaftabdichtung/without valve stem gasket/sans joint de tige de soupape/sin junta de vástago de válvula/без уплотнения стержня клапана						
<b>118</b>	<b>94,4</b>						
<b>8140.27 Euro 1</b>	<b>2565</b>	D (A)	4	2798 cm <sup>3</sup>	2V	78 kW (106 PS) 18,5:1 100,00 mm	
IN [2]	41,0 x 8 x 120,8	S - Cr -	- 30° -	-	9 - III	47 57 358 504069200 7 301 820 <b>171120</b>	
IN [2]	41,0 x 8 x 121,9	A/S - Ni -	- 30° -	-	1 - III	4813760 <b>17080</b>	
EX [2]	36,0 x 8 x 122,0	A/S - Cr -	- 45° -	-	9 - III	99432837 <b>171055</b>	
[50]	∅ 8 mm					<b>RK-8</b>	
[50]	∅ 8 mm					<b>RK-8H</b>	
IN/EX [4]	13,02 x 8.02 x 56,0	G1				4 749 395 <b>81-17116</b>	
IN/EX [4]	13,07 x 8.02 x 56,0	G1				4 749 397 <b>81-17115</b>	
IN/EX [4]	13,07 x 8.02 x 60,0	G1				4 726 483 4 733 258 <b>81-17114 (1)</b>	
IN/EX [4]	13,12 x 8 x 56,0	G1				4 749 398 <b>81-5611</b>	
(1)	ohne Ventilschaftabdichtung/without valve stem gasket/sans joint de tige de soupape/sin junta de vástago de válvula/без уплотнения стержня клапана						
Fortsetzung nächste Seite / continued on next page / suite page suivante / continuación página próxima / Продолжение на следующей странице							

**F**

					Reference	Item No.
[8]	M 44 x 32				4733350	50 006 180

**119** 95

8025.01	01.1966 → 12.1979	D	2	1560 cm <sup>3</sup>	2V	18 kW	(25 PS)	17:1	110,00 mm
8030.00	01.1966 → 1971	D (NA)	3	2340 cm <sup>3</sup>	2V	28-38 kW	(38-51 PS)	17:1	110,00 mm
8030.01	01.1971 → 05.1979	D	3	2340 cm <sup>3</sup>	2V	28-37 kW	(38-51 PS)	17:1	110,00 mm
8035.01	303								
	01.1968 → 03.1986	D	3	2338 cm <sup>3</sup>	2V	28-35 kW	(38-48 PS)	17:1	110,00 mm
8040.00		D (NA)	4	3120 cm <sup>3</sup>	2V	51 kW	(70 PS)	17:1	110,00 mm
8045.01	01.1966 → 1971	D	4	3120 cm <sup>3</sup>	2V	40-54 kW	(52-70 PS)	17:1	110,00 mm
806.000	01.1966 → 1971	D	6	4678 cm <sup>3</sup>	2V	66-81 kW	(90-110 PS)	17:1	110,00 mm
8060.01	01.1966 → 1971	D	6	4678 cm <sup>3</sup>	2V	66-81 kW	(90-110 PS)	17:1	110,00 mm
8065.01	000								
		D	6	4678 cm <sup>3</sup>	2V	66-81 kW	(90-110 PS)	17:1	110,00 mm

91 476 6..

IN [2]	43,9 x 8 x 125,8	B - Ni -	- 45° - -	2 - III	1 901 963 1 902 205 4 659 379 60 105 343	50 004 282
EX [2]	37,0 x 8 x 125,8	A/S - Cr -	- 45° - -	1 - III	4 621 484 4621484 4658055 4673608	17043
[50]	∅ 8 mm					RK-8H
IN/EX [4]	14,02 x 8 x 56,0	G1			4 648 421 4 802 126	81-17117

**120** 95,8

**F1CE0441A Euro 4** 04.2009 → BG (A) 4 2999 cm<sup>3</sup> 4V 100 kW (136 PS) 12,5 104,00 mm

IN [2]	32,4 x 6 x 119,9	S - -	- 30° - -	22 - III	504072531 504238926	171115
EX [2]	32,3 x 6 x 119,9	A/S - Cr -	- 30° - -	22 - III	504081062 504238928	171116
[50]	∅ 6 mm					MK-6H
	AS				504080985 504246093	50 007 047 <b>NEW</b> (1)
	ES				504080984 504246094	50 007 048 <b>NEW</b> (1)
	(1) Schalenhartguss/chilled cast iron/pièce moulée trempée en surface/fundición en coquilla/Отливка с отбеленным поверхностным слоем					
[4]					504380370	50 007 629 (2)
	(2) Hydr. tappet - 50006435					

**121** 95,8

**F1CE0481D Euro 4** 07.2006 → D (A) 4 2999 cm<sup>3</sup> 4V 115-116 kW (156-158 PS) 19 104,00 mm

IN [2]	32,4 x 6 x 119,9	S - -	- 30° - -	22 - III	504072531 504238926	171115
EX [2]	32,3 x 6 x 119,9	A/S - Cr -	- 30° - -	22 - III	504081062 504238928	171116

Fortsetzung nächste Seite / continued on next page / suite page suivante / continuación página próxima / Продолжение на следующей странице



					Reference	Item No.
[50]	Ø 6 mm					<b>MK-6H</b>
	ES				504080984 504246094	<b>50 007 048</b> (1)
	(1) Schalenhartguss/chilled cast iron/pièce moulée trempée en surface/fundición en coquilla/Отливка с отбеленным поверхностным слоем					
[8]	H 12 x 33,5 x 33,5				5801455560 9638075480	<b>50 006 435</b>

<b>122</b>		<b>95,8</b>							
<b>F1CE3481M Euro 5</b>	07.2006 →	D (LA)	4	2999 cm <sup>3</sup>	4V	115 kW	(156 PS)	17,5	104,00 mm
41 106 6..									

	AS					504080985 504246093	<b>50 007 047</b> (1)
	ES					504080984 504246094	<b>50 007 048</b> (1)
	(1) Schalenhartguss/chilled cast iron/pièce moulée trempée en surface/fundición en coquilla/Отливка с отбеленным поверхностным слоем						
[8]	H 12 x 33,5 x 33,5					5801455560 9638075480	<b>50 006 435</b>

<b>123</b>		<b>95,8</b>							
<b>F1CE3481E Euro 5</b>	06.2011 →	D (A)	4	2999 cm <sup>3</sup>	4V	130 kW	(177 PS)	17,5	104,00 mm
<b>F1CE3481N Euro 5</b>	04.2010 →	D (A)	4	2999 cm <sup>3</sup>	4V	103-107 kW	(140-145 PS)	17,5	104,00 mm
41 106 6..									

	AS					504080985 504246093	<b>50 007 047</b> (1)
	ES					504080984 504246094	<b>50 007 048</b> (1)
	(1) Schalenhartguss/chilled cast iron/pièce moulée trempée en surface/fundición en coquilla/Отливка с отбеленным поверхностным слоем						

<b>124</b>		<b>95,8</b>							
<b>4P10-T3 Euro 5</b>		D (A)	4	2998 cm <sup>3</sup>	4V	107 kW	(145 PS)		104,00 mm
<b>F1CE0481 (30DT) Euro 4</b>		D (LA)	4	2999 cm <sup>3</sup>	4V	116 kW	(158 PS)	19,0:1	104,00 mm

IN [2]	32,4 x 6 x 119,9	S - -	- 30° - -	22 - III	504072531 504238926	<b>171115</b>
EX [2]	32,3 x 6 x 119,9	A/S - Cr -	- 30° - -	22 - III	504081062 504238928	<b>171116</b>
[50]	Ø 6 mm					<b>MK-6H</b>

<b>125</b>		<b>95,8</b>							
<b>F1 CE 0481 E Euro 4</b>		D (LA)	4	2998 cm <sup>3</sup>	4V	100 kW	(136 PS)	19:1	104,00 mm
<b>F1 CE 0481 H Euro 4</b>		D (LA)	4	2998 cm <sup>3</sup>	4V	122 kW	(166 PS)		104,00 mm

IN [2]	32,4 x 6 x 119,9	S - -	- 30° - -	22 - III	504072531 504238926	<b>171115</b>
EX [2]	32,3 x 6 x 119,9	A/S - Cr -	- 30° - -	22 - III	504081062 504238928	<b>171116</b>
[50]	Ø 6 mm					<b>MK-6H</b>
[4]					504380370	<b>50 007 629</b> (1)
	(1) Hydr. tappet - 50006435					

					Reference	Item No.
<b>126</b>	<b>98,43</b>					
<b>4.236</b> 91 118 6..		D (NA)	4	3866 cm <sup>3</sup> 2V	55-65 kW (75-88 PS) 16:1	127,00 mm
	IN [2] IN [2]	44,2 x 9,5 x 122,8 44,2 x 9,5 x 122,8 M + 1	S - - S - -	- 45° - - - 45° - -	1 - III 1 - III	<b>105-03365</b> <b>105-35472</b>
	EX [2] EX [2]	36,5 x 9,5 x 123,2 36,6 x 9,5 x 123,3 M + 1	A/S - - A/S - -	- 45° - - - 45° - -	1 - III 1 - III	<b>105-03366</b> <b>105-35473</b>
	IN [6] EX [6]	15,90 x 9.515 x 57,9 15,90 x 9.53 x 61,1	G2 G2			<b>81-85003</b> <b>81-85004</b>
<b>127</b>	<b>100</b>					
<b>8025.02</b>	<b>001, 004, 304, 311</b> 1972 →		D	2	1727 cm <sup>3</sup> 2V	24 kW (32 PS) 17:1 110,00 mm
<b>8030.02</b>		01.1971 → 05.1979	D (NA)	3	2592 cm <sup>3</sup> 2V	46 kW (62 PS) 17:1 110,00 mm
<b>8035.02</b>	<b>201, 202, 210, 212, 261, 265, 276, 300, 302, 310, 312, 350, 353, 355, 356, 361, 365, 376</b> 1970 →		D	3	2592 cm <sup>3</sup> 2V	29-46 kW (39-62 PS) 17:1 110,00 mm
<b>8035.06</b>	<b>200, 206, 208, 216, 220, 222, 223, 306, 307, 308, 309, 317, 320, 321, 322, 323</b> 01.1984 →		D (NA)	3	2708 cm <sup>3</sup> 2V	33-41 kW (45-56 PS) 17:1 115,00 mm
<b>8040.02</b>	<b>041, 267, 300, 360, 367</b> 01.1971 →		D (NA)	4	2V	56-60 kW (76-82 PS) 17:1 110,00 mm
<b>8045.02</b>	<b>200, 211, 270, 276, 354, 356, 358, 359, 370, 376</b> 01.1973 →		D	4	3456 cm <sup>3</sup> 2V	47-52 kW (64-70 PS) 17:1 110,00 mm
<b>8045.06</b>	<b>216, 219, 220, 301, 306, 307, 308, 309, 317, 320, 321</b> D		D	4	3613 cm <sup>3</sup> 2V	48-51 kW (65-70 PS) 17:1 115,00 mm
<b>8045.06</b>	<b>200, 208, 213, 225, 319, 326</b> 01.1984 →		D (NA)	4	3613 cm <sup>3</sup> 2V	48-51 kW (65-69 PS) 17:1 115,00 mm
<b>8060.02</b>	<b>000, 001, 003, 070</b> 01.1970 →		D (NA)	6	5184 cm <sup>3</sup> 2V	90 kW (122 PS) 17:1 110,00 mm
<b>8065.02</b>	<b>200, 217</b> 1970 →		D (NA)	6	5184 cm <sup>3</sup> 2V	70-74 kW (95-101 PS) 17:1 110,00 mm
<b>8065.06</b>	<b>200, 300</b> 01.1990 →		D (NA)	6	5418 cm <sup>3</sup> 2V	72-74 kW (98-100 PS) 17:1 115,00 mm
99 567 6..						
	IN [2] EX [2]	43,9 x 8 x 125,8 37,0 x 8 x 125,8	B - Ni - A/S - Cr -	- 45° - - - 45° - -	2 - III 1 - III	1 901 963 1 902 205 4 659 379 60 105 343 <b>17043</b> 4 621 484 4621484 4658055 4673608
	[50]	∅ 8 mm				<b>RK-8H</b>
	IN/EX [4]	14,02 x 8 x 56,0	G1			4 648 421 4 802 126 <b>81-17117</b>
<b>128</b>	<b>100,96</b>					
<b>4.248</b> 92 144 8..	01.1972 →	D (NA)	4	4067 cm <sup>3</sup> 2V	53-66 kW (72-90 PS) 16:1	127,00 mm
	IN [2] IN [2]	44,2 x 9,5 x 122,8 44,2 x 9,5 x 122,8 M + 1	S - - S - -	- 45° - - - 45° - -	1 - III 1 - III	<b>105-03365</b> <b>105-35472</b>
	EX [2] EX [2]	36,5 x 9,5 x 123,2 36,6 x 9,5 x 123,3 M + 1	A/S - - A/S - -	- 45° - - - 45° - -	1 - III 1 - III	<b>105-03366</b> <b>105-35473</b>
Fortsetzung nächste Seite / continued on next page / suite page suivante / continuación página próxima / Продолжение на следующей странице						

					Reference	Item No.	
	IN [6] EX [6]	15,90 x 9.515 x 57,9 15,90 x 9.53 x 61,1	G2 G2			<b>81-85003</b> <b>81-85004</b>	
<b>129</b>		<b>101,05</b>					
<b>6.372.4</b> 93 175 6..		D (NA) 6	6100 cm <sup>3</sup> 2V	82-87 kW	(112-118 PS) 16:1	126,80 mm	
	IN [2] IN [2] EX [2] EX [2]	44,2 x 9,5 x 122,8 44,2 x 9,5 x 122,8 M + 1 36,5 x 9,5 x 123,2 36,6 x 9,5 x 123,3 M + 1	S - - S - - A/S - - A/S - -	- 45° - - 45° - - 45° - - 45° -	1 - III 1 - III 1 - III 1 - III	<b>105-03365</b> <b>105-35472</b> <b>105-03366</b> <b>105-35473</b>	
	IN [6] EX [6]	15,90 x 9.515 x 57,9 15,90 x 9.53 x 61,1	G2 G2			<b>81-85003</b> <b>81-85004</b>	
<b>130</b>		<b>102</b>					
<b>F4 AE 0481 B Euro 3</b>		D (LA) 4	3922 cm <sup>3</sup> 4V	125 kW	(170 PS) 17:1	120,00 mm	
	IN [2] EX [2]	33,0 x 7 x 124,7 33,0 x 7 x 124,3	S - Cr - A/S - Cr -	- 30° - - 45° -	9 - III 9 - III	4 895 052 4 895 051	
	[50]	Ø 7 mm				<b>RK-7H</b>	
	IN [2] EX [2]	34,91 x 29.6 x 5,8 34,91 x 29.5 x 5,8	G1 20° G1 20°			3943449 3943450	
<b>131</b>		<b>102</b>					
<b>F4 AE 3682 A Euro 4</b>		D (LA) 6	5883 cm <sup>3</sup> 4V			120,00 mm	
<b>F4 AE 3682 B Euro 4</b>		D (LA) 6	5883 cm <sup>3</sup> 4V			120,00 mm	
<b>F4 AE 3682 C Euro 4</b>		D (LA) 6	5883 cm <sup>3</sup> 4V			120,00 mm	
<b>F4 AE 3682 E Euro 4</b>		D (LA) 6	5883 cm <sup>3</sup> 4V	194 kW	(264 PS)	120,00 mm	
<b>F4AE0684C Euro 3</b>		D (LA) 6	5883 cm <sup>3</sup> 4V	169 kW	(230 PS) 17,5	120,00 mm	
40 352 6..							
	IN [2] EX [2]	33,0 x 7 x 124,7 33,0 x 7 x 124,3	S - Cr - A/S - Cr -	- 30° - - 45° -	9 - III 9 - III	4 895 052 4 895 051	
	[50]	Ø 7 mm				<b>RK-7H</b>	
<b>132</b>		<b>102</b>					
<b>F4AE3481A Euro 4/5</b>		D (LA) 4	3922 cm <sup>3</sup> 4V	130-134 kW	(177-182 PS)	120,00 mm	
<b>F4AE3481B Euro 4/5</b>		D (LA) 4	3922 cm <sup>3</sup> 4V	130 kW	(177 PS)	120,00 mm	
<b>F4AE3481C Euro 4/5</b>		D (LA) 4	3922 cm <sup>3</sup> 4V	103 kW	(140 PS)	120,00 mm	
<b>F4AE3481D Euro 4/5</b>		D (LA) 4	3922 cm <sup>3</sup> 4V	118 kW	(160 PS)	120,00 mm	
41 077 6..							
	[12]	M 16 x 54				4899803	
						<b>20 1014 06001</b>	

**F**

					Reference	Item No.	
<b>133</b>		<b>103</b>					
<b>8035.04</b>	<b>265, 270, 272, 300, 359, 376, 378</b> 11.1970 →	D (NA) 3	2749 cm <sup>3</sup>	2V	35-43 kW (48-58 PS)	17:1 110,00 mm	
<b>8040.04</b>	<b>200, 280</b> 04.1978 →	D (NA) 4	3666 cm <sup>3</sup>	2V	63 kW (85-86 PS)	17:1 110,00 mm	
<b>8045.04</b>	<b>189, 270, 275, 276, 293, 300, 359, 370, 376</b> 01.1978 →	D (NA) 4	3666 cm <sup>3</sup>	2V	48-57 kW (65-78 PS)	17:1 110,00 mm	
<b>8055.04</b>	<b>200, 205, 250</b> 01.1980 →	D (NA) 5	4583 cm <sup>3</sup>	2V	60-66 kW (82-90 PS)	17:1 110,00 mm	
<b>8060.04</b>	<b>051, 055, 060, 660, 660</b> 04.1978 →	D (NA) 6		2V	95-102 kW (130-139 PS)	110,00 mm	
<b>8065.04</b>	<b>089, 095, 097, 200, 270</b> 01.1976 →	D (NA) 6	5499 cm <sup>3</sup>	2V	53-85 kW (72-116 PS)	17:1 110,00 mm	
<b>8065.24</b>	<b>000, 091, 092, 098, 300</b> 1978 →	D (NA) 6	5499 cm <sup>3</sup>	2V	85-99 kW (115-135 PS)	16,5:1 110,00 mm	
90 654 6.., 93 311 6..							
	IN [2]	43,9 x 8 x 125,8	B - Ni -	- 45° - -	2 - III	1 901 963 1 902 205 4 659 379 60 105 343 <b>50 004 282</b>	
	EX [2]	37,0 x 8 x 125,8	A/S - Cr -	- 45° - -	1 - III	4 621 484 4621484 4658055 4673608 <b>17043</b>	
	[50]	Ø 8 mm				<b>RK-8H</b>	
	IN/EX [4]	14,02 x 8 x 56,0	G1			4 648 421 4 802 126 <b>81-17117</b>	
<b>134</b>		<b>103</b>					
<b>8060.24</b>	<b>001, 601</b> 12.1982 →	D (A) 6	5499 cm <sup>3</sup>	2V	124 kW (168-169 PS)	17:1 110,00 mm	
	EX [2]	37,0 x 8 x 125,8	A/S - Cr -	- 45° - -	1 - III	4 621 484 4621484 4658055 4673608 <b>17043</b>	
	[50]	Ø 8 mm				<b>RK-8H</b>	
	IN/EX [4]	14,02 x 8 x 56,0	G1			4 648 421 4 802 126 <b>81-17117</b>	
<b>135</b>		<b>103</b>					
<b>8060.25</b>	<b>4600</b> 06.1991 →	D (A) 6	5499 cm <sup>3</sup>	2V	130 kW (177 PS)	17,7:1 110,00 mm	
Fortsetzung nächste Seite / continued on next page / suite page suivante / continuación página próxima / Продолжение на следующей странице							

					Reference	Item No.
	IN [2] 45,5 x 8 x 125,5	S - Cr -	- 30° - -	1 - III	1904656 1908408 4784888 4803805 4824416 98435622 99432652	<b>17075</b>
	EX [2] 37,5 x 8 x 125,5	A/S - Cr -	- 45° - -	1 - III	1904655 1904666 1908409 1908410 4784889 4789890 4806717 4806718 99432717 99432718	<b>17076</b>
	[50] Ø 8 mm					<b>KK-8H</b>
	IN/EX [4] 14,02 x 8 x 56,0	G1			4 648 421 4 802 126	<b>81-17117</b>

<b>136</b>		<b>104</b>							
<b>8035.05</b>	<b>200, 206, 208, 265, 306, 307, 308, 309</b>								
	03.1984 →	D	3	2931 cm <sup>3</sup>	2V	42-44 kW	(57-60 PS)	17:1	115,00 mm
<b>8040.05</b>	<b>200, 230</b>								
	09.1988 →	D (NA)	4	3908 cm <sup>3</sup>	2V	65 kW	(88 PS)	17:1	115,00 mm
<b>8040.25</b>	<b>200, 207, 208, 220</b>								
	01.1988 →	D (A)	4	3908 cm <sup>3</sup>	2V	85 kW	(115-116 PS)	17:1	115,00 mm
<b>8040.25B</b>	<b>4200 (LTC)</b>								
		D (A)	4	3908 cm <sup>3</sup>	2V	75 kW	(102 PS)	17,7:1	115,00 mm
<b>8040.25X</b>	<b>4000</b>								
		D (A)	4	3908 cm <sup>3</sup>	2V	85 kW	(116 PS)	17,7:1	115,00 mm
<b>8040.45 Euro 2</b>	<b>5200, 5281</b>								
	09.1994 →	D (LA)	4	3908 cm <sup>3</sup>	2V	100 kW	(136 PS)	18:1	115,00 mm
<b>8040.45</b>	<b>4000 (TCA), 4180 (TCA)</b>								
		D (LA)	4	3908 cm <sup>3</sup>	2V	100 kW	(136 PS)		115,00 mm
<b>8040.45D Euro 2</b>	<b>5100, 5103</b>								
		D (LA)	4	3908 cm <sup>3</sup>	2V	85 kW	(116 PS)	18:1	115,00 mm
<b>8045.05</b>	<b>200, 204, 216, 217, 300, 304, 308, 317, 359, 389, 393, 395</b>								
	06.1984 →	D (NA)	4	3908 cm <sup>3</sup>	2V	57-60 kW	(78-82 PS)	17:1	115,00 mm
<b>8045.05</b>	<b>205, 206, 207, 208, 209, 306, 307, 309</b>								
	03.1984 →	D	4	3908 cm <sup>3</sup>	2V	57-59 kW	(78-80 PS)	17:1	115,00 mm
<b>8055.05</b>	<b>000</b>								
	01.1984 → 12.1991	D (NA)	5	4885 cm <sup>3</sup>	2V	66 kW	(90 PS)	17:1	115,00 mm
<b>8060.05</b>	<b>200, 200, 246, 270, 270, 280, 280, 285, 289</b>								
	07.1983 →	D (NA)	6	5861 cm <sup>3</sup>	2V	99-102 kW	(135-139 PS)		115,00 mm
<b>8060.25</b>	<b>400, 420, 600</b>								
	1986 →	D (A)	6		2V	130 kW	(175-177 PS)		115,00 mm
<b>8060.25 Euro 2</b>	<b>000</b>								
	1986 → 1991	D (LA)	6	5863 cm <sup>3</sup>	2V	130 kW	(177 PS)	16,5:1	115,00 mm
<b>8060.25R Euro 1</b>	<b>4200, 4280</b>								
		D (LA)	6	5861 cm <sup>3</sup>	2V	105 kW	(143 PS)	17,7:1	115,00 mm
<b>8060.25V Euro 1</b>	<b>4000, 4080</b>								
		D (LA)	6	5861 cm <sup>3</sup>	2V	130 kW	(177 PS)	17,7:1	115,00 mm
<b>8060.45 Euro 1</b>	<b>4100, 4180, 6000, 6090</b>								
		D (LA)	6		2V	152-167 kW	(207-227 PS)		115,00 mm
<b>8060.45</b>	<b>600</b>								
		D (LA)	6	5861 cm <sup>3</sup>	2V	152 kW	(207 PS)	17:1	115,00 mm
<b>8060.45B Euro 2</b>	<b>5160</b>								
	06.1991 →	D (LA)	6	5863 cm <sup>3</sup>	2V	130 kW	(177 PS)	18:1	115,00 mm
<b>8060.45K Euro 2</b>	<b>6096</b>								
		D (LA)	6	5863 cm <sup>3</sup>	2V	167 kW	(227 PS)	18:1	115,00 mm

Fortsetzung nächste Seite / continued on next page / suite page suivante / continuación página próxima / Продолжение на следующей странице



					Reference	Item No.
<b>8060.45M Euro 2</b>	<b>7280</b>					
		D (LA) 6	5863 cm <sup>3</sup> 2V	179 kW	(240 PS) 18:1	115,00 mm
<b>8060.45R Euro 2</b>	<b>5046</b>	D (LA) 6	5863 cm <sup>3</sup> 2V	105 kW	(143 PS) 18:1	115,00 mm
<b>8060.45X Euro 2</b>	<b>4182</b>	D (LA) 6	5863 cm <sup>3</sup> 2V	152 kW	(207 PS) 17:1	115,00 mm
<b>8065.05</b>	<b>000, 220</b>					
	03.1982 →	D (NA) 6	5863 cm <sup>3</sup> 2V	81-85 kW	(110-116 PS) 18:1	115,00 mm
<b>8065.25</b>	<b>220</b>					
	09.1990 →	D (A) 6	5863 cm <sup>3</sup> 2V	95 kW	(130 PS) 17:1	115,00 mm
<b>8065.25</b>	<b>010</b>					
	01.1984 → 12.1996	D (NA) 6	5863 cm <sup>3</sup> 2V	94-96 kW	(128-131 PS) 16,5:1	115,00 mm

90 152 6., 90 158 7., 94 450 6..

	IN [2]	45,5 x 8 x 125,5	S - Cr -	- 30° - -	1 - III	1904656 1908408 4784888 4803805 4824416 98435622 99432652	<b>17075</b>
	EX [2]	37,5 x 8 x 125,5	A/S - Cr -	- 45° - -	1 - III	1904655 1904666 1908409 1908410 4784889 4789890 4806717 4806718 99432717 99432718	<b>17076</b>
	[50]	∅ 8 mm					<b>KK-8H</b>
	IN/EX [4]	14,02 x 8 x 56,0	G1			4 648 421 4 802 126	<b>81-17117</b>

**137**
**104**

<b>8060.45S Euro 1</b>	<b>6000, 6070, 6700, 6800</b>						
		D (LA) 6	2V	167 kW	(227 PS) 17:1	115,00 mm	

	IN [2]	46,0 x 9 x 141,2	S - Cr -	- 30° - -	1 - III	1908394 98429886 98497235	<b>171019</b>
	[50]	∅ 9 mm					<b>KK-9H</b>

**138**
**112**

<b>8360.46 Euro 1</b>	<b>415, 507, 6307, 697</b>						
		D (LA) 6	7685 cm <sup>3</sup> 2V	196 kW	(267 PS) 17,6:1	130,00 mm	
<b>8360.46 Euro 2</b>	<b>4107, 4205, 4370, 4637, 4649, 4807, 5007, 5105, 5307, 6205</b>						
	01.1995 →	D (LA) 6	7685 cm <sup>3</sup> 2V	196 kW	(267 PS) 17,6:1	130,00 mm	
<b>8360.46R Euro 1</b>	<b>676</b>						
		D (LA) 6	7685 cm <sup>3</sup> 2V	175 kW	(238 PS) 17,6:1	130,00 mm	
<b>8360.46R Euro 2</b>	<b>4106, 6806</b>						
		D (LA) 6	7685 cm <sup>3</sup> 2V	175 kW	(238 PS) 17,6:1	130,00 mm	

	EX [2]	42,5 x 9 x 142,3	RA/S- Cr -	- 45° - -	1 - III	1908427 4860107 99438924	<b>171018</b>
	[50]	∅ 9 mm					<b>KK-9H</b>

					Reference	Item No.	
<b>139</b>		<b>115</b>					
<b>8340.04</b>	<b>000</b>	09.1977 → 12.1980	D	4	4570 cm <sup>3</sup> 2V	66-74 kW (90-100 PS) 17:1	110,00 mm
<b>8340.05</b>	<b>000</b>	1977 →	D	4	5401 cm <sup>3</sup> 2V	78 kW (106 PS) 17:1	130,00 mm
<b>8340.06</b>	<b>000</b>	06.1977 → 01.1987	D	4	4570 cm <sup>3</sup> 2V	74 kW (100 PS) 17:1	110,00 mm
<b>8360.04</b>	<b>200, 300</b>	05.1978 →	D	6	6855 cm <sup>3</sup> 2V	106-107 kW (145 PS) 17:1	110,00 mm
<b>8360.05</b>	<b>300, 670</b>	01.1979 →	D	6	8101 cm <sup>3</sup> 2V	117-119 kW (159-162 PS) 17:1	130,00 mm
<b>8360.05</b>	<b>200, 254</b>	03.1977 → 12.1990	D (NA)	6	8102 cm <sup>3</sup> 2V	124 kW (169 PS) 17:1	130,00 mm
<b>8365.05</b>	<b>500, 520, 530, 531, 555, 560, 570, 580, 590</b>	01.1978 →	D (NA)	6	8101 cm <sup>3</sup> 2V	94-114 kW (128-155 PS) 17:1	130,00 mm
<b>8365.25</b>	<b>500, 533, 590</b>	01.1980 →	D (A)	6	2V	118-133 kW (160-181 PS) 15,5:1	130,00 mm
93 208 6..., 93 209 6..							
	IN [2]	48,5 x 8 x 137,5	B - Ni -	- 45° - -	2 - III	4821709 4821710 8824754	<b>50 009 050</b>
	EX [2]	41,0 x 8 x 137,5	A/S - Ni -	- 45° - -	1 - III	8 830 045	<b>17072</b>
	[50]	∅ 8 mm					<b>KK-8H</b>
	IN/EX [4]	14,02 x 8 x 56,0	G1			4 648 421 4 802 126	<b>81-17117</b>
<b>140</b>		<b>115</b>					
<b>F2BE0681E Euro 2</b>			D (LA)	6	7790 cm <sup>3</sup> 4V	218 kW (296 PS) 17:1	125,00 mm
<b>F2BE0681F Euro 2</b>			D (LA)	6	7790 cm <sup>3</sup> 4V	200 kW (272 PS) 17:1	125,00 mm
40 316 6..., 40 317 6..							
	IN [2]	40,0 x 8 x 174,5	S - Cr -	- 30° - -	1 - III	500354682 500354685 504042365 504127798 99456803	<b>171070</b>
	EX [2]	39,0 x 8 x 173,3	RA/S- Cr -	- 45° - -	1 - III	504042363	<b>171108</b>
	[50]	∅ 8 mm					<b>KK-8H</b>
	IN [4]	13,03 x 8.02 x 75,5	G2			500391440	<b>81-17130</b>
	EX [4]	13,03 x 8.02 x 75,5	G2			500391436	<b>81-17131</b>
<b>141</b>		<b>117</b>					
<b>F2CE0681A</b>			D (LA)	6	8709 cm <sup>3</sup> 4V	294 kW (400 PS)	135,00 mm
<b>F2CE0682A</b>			D (LA)	6	8709 cm <sup>3</sup> 4V	294 kW (400 PS)	135,00 mm
<b>F2CE0683A</b>			D (LA)	6	8709 cm <sup>3</sup> 4V	294 kW (400 PS)	135,00 mm
<b>F2CE0684A</b>			D (LA)	6	8709 cm <sup>3</sup> 4V	294 kW (400 PS)	135,00 mm
	IN [2]	40,0 x 8 x 174,5	S - Cr -	- 30° - -	1 - III	500354682 500354685 504042365 504127798 99456803	<b>171070</b>
	EX [2]	39,0 x 8 x 173,3	RA/S- Cr -	- 45° - -	1 - III	504042363	<b>171108</b>
	[50]	∅ 8 mm					<b>KK-8H</b>
	IN [4]	13,03 x 8.02 x 75,5	G2			500391440	<b>81-17130</b>
	EX [4]	13,03 x 8.02 x 75,5	G2			500391436	<b>81-17131</b>

**F**

					Reference	Item No.	
<b>142</b>		<b>120</b>					
<b>8460.21</b>	<b>002</b>						
	01.1987 →	D (LA)	6	9498 cm <sup>3</sup>	2V	154-192 kW (209-261 PS) 16:1	140,00 mm
<b>8460.21</b>	<b>004, 006, 008, 020, 042, 106</b>						
		D (A)	6	9498 cm <sup>3</sup>	2V	176-192 kW (239-261 PS) 16:1	140,00 mm
<b>8460.41</b>	<b>101</b>						
	02.1991 →	D (LA)	6	9498 cm <sup>3</sup>	2V	234 kW (318 PS) 16:1	140,00 mm
	IN [2]	49,5 x 9 x 147,3	A/S - Cr -	- 30° - -	1 - III	61316814 61320722	<b>17165</b>
	EX [2]	43,0 x 9 x 146,0	RA/S- Cr -	- 45° - VS -	1 - III	61315973 61321255	<b>171121</b>
<b>143</b>		<b>125</b>					
<b>F3AE0681B Euro 3</b>		D (LA)	6	10308 cm <sup>3</sup>	4V	294 kW (400 PS) 17:1	140,00 mm
<b>F3AE0681E Euro 2</b>		D (LA)	6	10308 cm <sup>3</sup>	4V	287 kW (390 PS) 17:1	140,00 mm
40 339 6..							
	IN [2]	43,0 x 9 x 202,9	S - Cr -	- 30° - -	1 - III	500355776 504042366 5801551446	<b>171072</b>
	EX [2]	42,0 x 9 x 201,6	RA/S- Cr -	- 45° - -	1 - III	500355779 504042367	<b>171109</b>
	[50]	∅ 9 mm					<b>KK-9H</b>
	IN [1]	15,02/13 x 9,02 x 97,0 G2				500391479	<b>81-17134</b>
	EX [1]	15,02/13 x 9,02 x 97,0 G2				500391476	<b>81-17135</b>
						504004779 504221496	<b>20 1014 08000</b>
<b>144</b>		<b>135</b>					
<b>F3 BEE 681 C Euro 4</b>		D (LA)	6	12882 cm <sup>3</sup>	4V	324 kW (441 PS) 16,5:1	150,00 mm
<b>F3 BEE 681 D Euro 4</b>		D (LA)	6	12882 cm <sup>3</sup>	4V	316 kW (430 PS) 16,5:1	150,00 mm
<b>F3 BEE 681 E Euro 4</b>		D (LA)	6	12882 cm <sup>3</sup>	4V	316 kW (430 PS) 16,5:1	150,00 mm
<b>F3 BEE 681 G Euro 4</b>		D (LA)	6	12882 cm <sup>3</sup>	4V	280 kW (381 PS) 16,5:1	150,00 mm
<b>F3 BEE 681 V Euro 4</b>		D (LA)	6	12882 cm <sup>3</sup>	4V	310 kW (421 PS) 16,5:1	150,00 mm
40 340 6..							
	IN [2]	47,0 x 10 x 199,3	S - Cr -	- 30° - -	1 - III	500355778	<b>171111</b>
	EX [2]	46,0 x 10 x 198,1	A/S - Cr -	- 45° - -	1 - III	500355780 504080352 504293892	<b>171112</b>
	[50]	∅ 10 mm					<b>KK-10H</b>
	IN [4]	16,03/14 x 10 x 97,0	G2			500390993	<b>81-17132</b>
	EX [4]	16,03/14 x 10 x 97,0	G2			500390994	<b>81-17133</b>

**F**

					Reference	Item No.	
<b>145</b>		<b>137</b>					
<b>8210.12</b>	<b>000</b>		D 6 13798 cm <sup>3</sup> 2V	191 kW (260 PS) 16:1		156,00 mm	
<b>8210.22</b>	<b>105, 419, 510, 559, 571, 575, 581, 583, 585, 591, 859</b>		D (LA) 6 13798 cm <sup>3</sup> 2V	220-243 kW (300-330 PS)		156,00 mm	
<b>8210.22</b>	<b>000, 101, 171, 175, 183, 235, 269, 317, 327, 371, 373, 385, 406, 409, 569, 599, 631, 869</b>		D (A) 6 13798 cm <sup>3</sup> 2V	220-235 kW (300-320 PS)		156,00 mm	
<b>8210.22</b>	<b>069</b>		D (NA) 6 13798 cm <sup>3</sup> 2V	221-224 kW (300-305 PS) 15:1		156,00 mm	
<b>8210.42K Euro 1</b>	<b>330, 331, 332, 340, 341, 342, 349, 369, 379, 850, 852, 862, 875, 877</b>		D (LA) 6 13798 cm <sup>3</sup> 2V	272 kW (370 PS) 16,5:1		156,00 mm	
<b>8210.42K Euro 2</b>	<b>3230, 3300, 3301, 3320, 3330, 3420, 3440, 3690</b>		D (LA) 6 13798 cm <sup>3</sup> 4V	272 kW (370 PS) 16;5:1		156,00 mm	
<b>8210.42L Euro 1</b>	<b>400, 412, 430, 432, 441, 449, 460, 462, 469, 479</b>		D (LA) 6 13798 cm <sup>3</sup> 2V	309 kW (420 PS) 16,5:1		156,00 mm	
<b>8210.42L Euro 2</b>	<b>4300, 4301, 4320, 4330, 4420, 4440, 4490, 4601, 4610, 4611, 4640, 4880, 4930</b>		D (LA) 6 13798 cm <sup>3</sup> 2V	309 kW (420 PS) 16,5:1		156,00 mm	
<b>8210.42M Euro 2</b>	<b>5000, 5400, 5600, 5601, 5611, 5620, 5640</b>		D (LA) 6 13798 cm <sup>3</sup> 2V	345 kW (470 PS) 16,5:1		156,00 mm	
<b>8215.22</b>	<b>542</b>		D (A) 6 13798 cm <sup>3</sup> 2V	182 kW (247 PS) 15:1		156,00 mm	
	EX [1]	48,0 x 11 x 170,0	RA/S- Cr -	- 45° - -	1 - III	4673861	<b>171110</b>
	[50]	Ø 11 mm					<b>KK-11H</b>
	IN [6] EX [6]	18,04 x 11 x 86,0 18,04 x 11 x 76,0	G1 G1			4630923 4648237	<b>81-17126</b> <b>81-17127</b>

**F**

			Cyl.		mm	cm <sup>3</sup>	Comp. Ratio	€	kW	PS	Pos
15DSOX	D (A)	4	73,5 x 88,3	1499	2				66-74	91-101	11
169A1000 Euro 4/5	D (A)	4	69,6 x 82	1248	4	17,6		55	75	1	
1Z	D (LA)	4	79,5 x 95,5	1896	2	19,5		66	90	44	
2502 E	D	3	106,68 x 96,52	2589	2	17,3:1		25-30	34-41	150	
2504 E	D	3	106,698 x 106,68	2870	2	16,5:1		35	47	151	
2512 E	D	3	111,778 x 111,76	3294	2	16,5:1		44	60	155	
2700	D	4	104,775 x 114,9	3966	2	16,5:1		61	83	149	
2701 E	D	4	104,775 x 114,9	3966	2	16,5:1		61	83	149	
2703 E	D	6	104,775 x 114,80	5939	2	16,5:1		61	83	149	
2704 E	D	6	104,775 x 114,9	5944	2	16,5:1		97	130	149	
2706 E	D	4	104,775 x 114,9	3966	2	16,5:1		61	83	149	
2708 E	D	6	100,775 x 114,8	5494	2	16,5:1		61	83	146	
2709 E	D	6	104,775 x 114,9	5944	2	16,5:1		97	130	149	
2711 E	D	4	107,21 x 114,96	4161	2	16,5:1		55	75	154	
2712 E	D	4	107,21 x 114,96	4161	2	16,5:1		50-59	68-80	154	
2714 E	D	6	107,21 x 114,8	6227	2	16,5:1		77	105	154	
2715 C	D	6	107,21 x 114,8	6227	2	16:1		82	112	154	
2715 E	D	6	107,21 x 114,8	6227	2	16,5:1		77-86	105-117	154	
360 DT	D (A)	6	104,775 x 114,9	5944	2	15,7:1		106	144	149	
4 BTA 3.9 Euro 2	D (LA)	4	102 x 120	3922	2	17,5:1		57-97	78-132	148	
4BA	D (NA)	4	93,67 x 90,5	2496	2	19,5		52	71	140	
4DA	D (NA)	4	93,67 x 90,54	2496	2	20,6		59	80	140	
4EA	D (A)	4	93,67 x 90,5	2496	2	18,3		74	100	140	
4EB	D (A)	4	93,7 x 90,6	2496	2	18,3		74	101	142	
4EC	D (A)	4	93,7 x 90,6	2496	2	18,3		74	101	142	
4ED	D (A)	4	93,67 x 90,54	2496	2	18		85	116	140	
4FB	D (NA)	4	93,7 x 90,6	2496	2	20,5		51	70	142	
4FC	D (NA)	4	93,7 x 90,6	2496	2	20,5		51	70	142	
4FD	D (NA)	4	93,7 x 90,6	2496	2	20,6:1		51	69	142	
4G63	B (NA)	4	85 x 88	1997	2	8,6		78	106	86	
4GA	D (A)	4	93,67 x 90,54	2496	2	20,6		63	85	140	
4GB	D (A)	4	93,67 x 90,54	2496	2	20,6		63	85	140	
4GC	D (A)	4	93,67 x 90,54	2496	2	20,6		63	85	140	
4GD	D (A)	4	93,67 x 90,54	2496	2	20,6		63	86	140	
4GE	D (A)	4	93,7 x 90,6	2496	2	20,6:1		63	86	142	
4GF	D (A)	4	93,7 x 90,6	2496	2	20,6		63	85	141	
4HA	D (NA)	4	93,67 x 90,54	2496	2	20,6		55-56	75-76	140	
4HB	D (NA)	4	93,67 x 90,54	2496	2	20,6		56	76	140	
4HC	D (NA)	4	93,7 x 90,6	2496	2	20,6		56	76	142	
4RB	B (NA)	4	87,68 x 66	1593	2	8		48	65	118	
4RC	B (NA)	4	90,83 x 77	1993	2	8		43-57	59-78	134	
592 E	D	4	100,775 x 114,96	3611	2	16:1		51	69	146	
6 BTAA Euro 2	D (LA)	6	102 x 120	5883	2	17-17,6		94-173	124-235	147	
6 CTAA 8.3	D (LA)	6	114 x 135	8268	2	17,5:1		213-235	290-320	157	
675 TA/HD	D (LA)	6	111,8 x 127	7480	4			106	144	156	
6Y 4.2	D (A)	4	111,778 x 106,7	4195	2	15,6:1		69	94	155	
6Y 6.6	D	6	111,778 x 111,76	6588	2	16,3:1		76	104	155	
7A 4.2	D (A)	4	111,778 x 106,68	4195	2	16,5:1		69	94	155	
7A 6.6 102 kW	D (A)	6	111,778 x 111,75	6588	2	16:1		102-137	138-186	155	
7A 6.6 81 kW	D	6	111,778 x 111,76	6588	2	16,3:1		81	110	155	
AAA	B (NA)	6	81 x 90,3	2792	2	10		128	174	64	
ABFA	D (A)	4	86 x 86	1998	4	19		74	101	104	
AEDA	D (A)	4	73,5 x 88,3	1499	2	16		77	105	12	
AFN	D (LA)	4	79,5 x 95,5	1896	2	19,5		81	110	44	
AHU	D (LA)	4	79,5 x 95,5	1896	2	19,5		66	90	44	
AHW Euro 6	D (A)	4	85 x 88	1997	4			133	180	97	
AHX Euro 6	D (A)	4	85 x 88	1997	4			110	150	97	
AMY	B (NA)	6	81 x 90,3	2792	2	10		128	174	63	
ANU	D (LA)	4	79,5 x 95,5	1896	2	18		66	90	46	
AOBA Euro 4	B (NA)	4	87,5 x 83,1	1999	4	10,8		107	145	115	
AOBC	B (NA)	4	87,5 x 83,1	1999	4	10,8		107	145	115	
AODA	B (NA)	4	87,5 x 83,1	1999	4	10,8		107	145	115	
AODB	B (NA)	4	87,5 x 83,1	1999	4	10,8		107	145	115	
AODE	B (NA)	4	87,5 x 83,1	1999	4	10,8		104-107	141-145	115	
AOWA	B (NA)	4	87,5 x 83,1	1999	4	10,8		107	145	115	
AOWB	B (NA)	4	87,5 x 83,1	1999	4	10,8		107	145	115	
ARC	B (NA)	6	84 x 72	2394	2	9,5		96	130	79	
ASD	B	4	76 x 76,5	1388	4	11:1		59	80	32	



		Cyl.		mm	cm <sup>3</sup>		Comp. Ratio $\epsilon$	kW	PS	Pos
ASDA	B (NA)	4		76 x 76,5	1388	4	11	59	80	32
ASDB	B (NA)	4		76 x 76,5	1388	4	11	59	80	32
ASZ	D (LA)	4		79,5 x 95,5	1896	2	19:1	96	130	46
AUY	D (LA)	4		79,5 x 95,5	1896	2	18	85	115	46
AVG	D (A)	4		79,5 x 95,5	1896	2	19,5	81	110	45
AYL	B (NA)	6		81 x 90,3	2792	4	10,5	150	204	65
AZBA	D (LA)	4		85 x 88	1997	4	18	96	131	87
AZBC	D (LA)	4		85 x 88	1997	4	18	100-103	136-140	87
AZWA	D (LA)	4		85 x 88	1997	4	17,9	96	130	87
AZWC	D (LA)	4		85 x 88	1997	4	18	100	136	87
B	B (NA)	4		87,68 x 66	1593	2	8	48	65	118
B3DA Euro 6	B (A)	3		71,9 x 82	999	4	10,5	74	101	10
B3GA Euro 6	B (A)	3		71,9 x 81,9	998	4		74	100	10
B7DA Euro 6	B (A)	3		71,9 x 82	999	4	10,5	92	125	10
B7JA Euro 6	B (A)	3		71,9 x 82	999	4		92	125	10
B7JB Euro 6	B (A)	3		71,9 x 82	999	4		92	125	10
B7JC Euro 6	B (A)	3		71,9 x 82	999	4		92	125	10
BAAA Euro 4/5	D (A)	4		69,6 x 82	1248	4	17,6	55	75	3
BCCC	D (LA)	4		84 x 90	1995	4		140	190	80
BHDA	D (A)	4		82,5 x 82	1753	2	19,4:1	55-57	75-78	73
BHDB	D (A)	4		82,5 x 82	1753	2	19,4:1	55-57	75-78	73
BHPA	D (LA)	4		82,5 x 82	1753	2	19,4:1	55-57	75-78	73
BJFA Euro 6	D (A)	4		84,01 x 90,03	1995	4		77	105	81
BJFB Euro 6	D (A)	4		84,01 x 90,03	1995	4		77	105	81
BKFA Euro 6	D (A)	4		84,01 x 90,03	1995	4		96	130	81
BKFB Euro 6	D (A)	4		84,01 x 90,03	1995	4		96	130	81
BLFA Euro 6	D (A)	4		84,01 x 90,03	1995	4		125	170	81
BLFB Euro 6	D (A)	4		84,01 x 90,03	1995	4		125	170	81
BRC	B (NA)	6		93 x 72	2933	2	9,5	110	150	138
BRT	B (NA)	6		93 x 72	2935	2	9,5	104-107	141-145	139
BSD 444	D	4		111,778 x 111,89	4392	2	16,3:1	60	82	155
BSD 444 T	D (A)	4		111,778 x 111,89	4392	2	15,6:1	68	92	155
BTB	D (LA)	4		79,5 x 95,5	1896	2	19:1	110	150	47
BZJA Euro 6	B (A)	3		71,9 x 82	999	4		114	155	10
C	B (K)	4		90,83 x 77	1993	2	8:1	43-55	59-75	134
C9DA	D (LA)	4		82,5 x 82	1753	2	19,4	66	90	73
C9DB	D (LA)	4		82,5 x 82	1753	2	19,4	66	90	73
C9DC	D (A)	4		82,5 x 82	1753	2	19,4	66	90	73
CFBA	B (NA)	4		83 x 83,1	1798	4	11,3	96	130	75
CGBA	B (NA)	4		83 x 83,1	1798	4	10,8	81	110	75
CHBA	B (NA)	4		83 x 83,1	1798	4	10,8	92	125	75
CJBA	B (NA)	4		87,5 x 83,1	1999	4	10,8	106-107	144-146	115
CJBB	B (NA)	4		87,5 x 83,1	1999	4	10,8	107	146	115
CSDA	B (NA)	4		83 x 83,1	1798	4	10,8	88	120	75
CSDB	B (NA)	4		83 x 83,1	1798	4	10,8	88	120	75
CV24	D (LA)	4		86 x 94,6	2198	4		114	155	109
CVF5	D (LA)	4		86 x 94,6	2198	4	15,5	114	155	107
CVFF	D (LA)	4		86 x 94,6	2198	4	15,5	114	155	107
CVR5	D (LA)	4		86 x 94,6	2198	4	15,5	114	155	111
CVRA	D (LA)	4		86 x 94,6	2198	4	15,5	114	155	111
CVRB	D (LA)	4		86 x 94,6	2198	4	15,5	114	155	111
CVRC	D (LA)	4		86 x 94,6	2198	4	15,5	114	155	109
CY14	D (LA)	4		86 x 94,6	2198	4	15,5	92	125	109
CY24	D (LA)	4		86 x 94,6	2198	4	15,5	92	125	109
CYF4	D (LA)	4		86 x 94,6	2198	4	15,5	92	125	109
CYF5	D (LA)	4		86 x 94,6	2198	4	15,5	92-99	125-135	107
CYFA	D (LA)	4		86 x 94,6	2198	4	15,5	92	125	107
CYFB	D (LA)	4		86 x 94,6	2198	4	15,5	92	125	107
CYFC	D (LA)	4		86 x 94,6	2198	4	15,5	92	125	107
CYFD	D (LA)	4		86 x 94,6	2198	4	15,5	92	125	109
CYFF	D (LA)	4		86 x 94,6	2198	4	15,5	92	125	107
CYFG	D (LA)	4		86 x 94,6	2198	4	15,5	92	125	107
CYR5	D (A)	4		86 x 94,6	2198	4	15,5	92	125	112
CYRA	D (LA)	4		86 x 94,6	2198	4	15,5	92	125	111
CYRB	D (LA)	4		86 x 94,6	2198	4	15,5	92	125	111
CYRC	D (LA)	4		86 x 94,6	2198	4	15,5	92	125	109
D2FA	D (LA)	4		89,9 x 94,6	2402	4	19	66	90	121
D2FB	D (LA)	4		89,9 x 94,6	2402	4	19	66	90	121
D2FE	D (LA)	4		89,9 x 94,6	2402	4	19	66	90	122

F

Cyl.	mm	cm <sup>3</sup>	Comp. Ratio $\epsilon$	kW	PS	Pos	
D3FA	D (A) 4	86 x 86	1998 4	19:1	55	75	104
D4FA	D (LA) 4	89,9 x 94,6	2402 4	19	88	120	121
D5BA	D (A) 4	86 x 86	1998 4	19,5	66	90	104
D6BA	D (A) 4	86 x 86	1998 4	19,5	85	115	104
DHA	B (NA) 4	71,9 x 76,5	1242 4	10	55	75	5
DHB	B (NA) 4	71,9 x 76,5	1242 4	10	55	75	5
DHC	B (NA) 4	71,9 x 76,5	1242 4	10	55	75	5
DHD	B (NA) 4	71,9 x 76,5	1242 4	10	55	75	5
DHE	B (NA) 4	71,9 x 76,5	1242 4	10	55	75	5
DHF	B (NA) 4	71,9 x 76,5	1242 4	10	55	75	5
DHG	B (NA) 4	71,9 x 76,5	1242 4	10	55	75	5
DOFA	D (LA) 4	89,9 x 94,6	2402 4	18,5	92	125	121
DRF4	D (LA) 4	86 x 94,6	2198 4	15,5	74	101	109
DRF5	D (A) 4	86 x 94,6	2198 4	15,5	74	100	107
DRFA	D (LA) 4	86 x 94,6	2198 4	15,5	74	101	107
DRFB	D (LA) 4	86 x 94,6	2198 4	15,5	74	101	107
DRFC	D (LA) 4	86 x 94,6	2198 4	15,5	74	101	107
DRFD	D (LA) 4	86 x 94,6	2198 4	15,5	74	101	109
DRFE	D (LA) 4	86 x 94,6	2198 4	15,5	74	101	109
DRFF	D (LA) 4	86 x 94,6	2198 4	15,5	74	100	107
DRFG	D (LA) 4	86 x 94,6	2198 4	15,5	74	100	107
DRR5	D (A) 4	86 x 94,6	2198 4	15,5	74	100	111
DRRA	D (LA) 4	86 x 94,6	2198 4	15,5	74	101	111
DRRB	D (LA) 4	86 x 94,6	2198 4	15,5	74	101	111
DRRC	D (LA) 4	86 x 94,6	2198 4	15,5	74	101	109
EDBA	B (NA) 4	84,8 x 88	1988 4	10	96	131	82
EDBB	B (NA) 4	84,8 x 88	1988 4	10	96	131	82
EDBC	B (NA) 4	84,8 x 88	1988 4	10	96	131	82
EDBD	B (NA) 4	84,8 x 88	1988 4	10	96	131	82
EDDB	B (NA) 4	84,8 x 88	1988 4	10	96	131	82
EDDC	B (NA) 4	84,8 x 88	1988 4	10	96	131	83
EYDB	B (NA) 4	80,6 x 88	1796 4	10	85	115	59
EYDC	B (NA) 4	80,6 x 88	1796 4	10	85	115	59
EYPA	B (NA) 4	80,6 x 88	1796 4	10:1	85	116	59
F 6 L 413 FZ	D	125 x 130	9572 2		150	204	159
F 6L 413 F	D (NA) 6	125 x 130	9572 2	18:1	104-188	141-256	160
F3AE3681D Euro 4/5	D (LA) 6	125 x 140	10308 4		310	422	161
F3FA	D (A) 4	86 x 86	1998 4	19:1	63	86	104
F4A	B (NA) 4	77,25 x 74,3	1392 2	8,5	54	73	35
F4B	B (NA) 4	77,25 x 74,3	1392 2	8,5	54-55	73-75	35
F4FA	D (LA) 4	89,9 x 94,6	2402 4	19	55	75	123
F6A	B (NA) 4	77,25 x 74,3	1393 2	8,5	52-54	71-73	36
F6B	B (NA) 4	77,25 x 74,3	1392 2	8,5	52-54	71-73	35
F6C	B (NA) 4	77,25 x 74,3	1392 2	8,5	52	71	35
F6D	B (NA) 4	77,25 x 74,3	1392 2	9,5	54	73	35
F6E	B (NA) 4	77,25 x 74,3	1392 2	8,5	52	71	35
F6F	B (NA) 4	77,25 x 74,3	1392 2	8,5	52	71	35
F6G	B (NA) 4	77,24 x 74,3	1392 2	8,5	52	71	33
F6JA	D (A) 4	73,7 x 82	1399 2	17,9-18	50-51	68-69	13
F6JB	D (A) 4	73,7 x 82	1399 2	17,9	50	68	13
F6JC	D (A) 4	73,7 x 82	1399 2	17,9	50	68	13
F6JD	D (LA) 4	73,7 x 82	1399 2	17,9	50-51	68-70	15
F9DA	D (LA) 4	82,5 x 82	1753 2	18,5	85	115	73
F9DB	D (LA) 4	82,5 x 82	1753 2	18,5	85	115	73
FD4 Euro 4/5	D (A) 4	69,6 x 82	1248 4	17,6	55	75	2
FFBA	D (LA) 4	82,5 x 82	1753 2	18,5	74	100	73
FFDA Euro 2	D (LA) 4	82,5 x 82	1753 2	18,5	74	100	73
FFWA	D (A) 4	82,5 x 82	1753 2	18,5	74	100	73
FHA	B (NA) 4	76 x 76,5	1388 4	10,3	66	90	31
FHD	B (NA) 4	76 x 76,5	1388 4	10,3	66	90	28
FHE	B (NA) 4	76 x 76,5	1388 4	10,3	66	90	31
FHF	B (NA) 4	76 x 76,5	1388 4	10,3	66	90	31
FIFA	D (A) 4	86 x 86	1998 4	19:1	92	125	104
FMBA	D (A) 4	86 x 86	1998 4	18,2	96	130	104
FP4	B (NA) 4	70,8 x 78,9	1242 2	11,1	51	69	4
FS	B (NA) 4	83 x 92	1991 4	9:1	85	116	77
FU	B	77,25 x 74,3	1392 2	9,5:1	55	75	37
FUA	B (NA) 4	77,25 x 74,3	1392 2	9,5	55	75	35
FUAA	B (NA) 4	77,25 x 74,3	1392 2	9,5	51-55	69-75	34



HXDA	HXDB	HXJA	HXJB	HXJD	HYDA	HYDB	HYDC Euro 5	IQDB	IQJA	ISB 4.5L Euro 6	ISB 6.7L Euro 6	ISC 8.3L Euro 3	ISL e Euro 4/5	J1E	J1F	J2	JAC	JCT	JLA	JPA	JPC	JQDA	JQDB	JQMA	JQMB	JTBA	JTBB	JTDA	JTDB	JTJA Euro 5	JTJB	JTMA	JTWA	JTWB	JXFA Euro 4	JXFC	KHBA	KKDA Euro 4	KKDB Euro 4	KLBA Euro 4	KLWA	KNBA	KNBB	KNWA	KNWB	KVJA	L1E	L1F	L1G	L1H	L1J	L1K	L1L	L1N	L1Q	L1T	L1V	L3E	L4B	L6B	LC	LCBA	LCBB	LCBC	LCBD	LCBE	LCE	LCN	Cyl.	 mm	cm <sup>3</sup>	 Comp. Ratio ε	kW	PS	Pos
B (NA) 4	79 x 81,4	1596	4	11	85	115	42																																																																				
B (NA) 4	79 x 81,4	1596	4	11:1	85	115	42																																																																				
B (NA) 4	79 x 81,4	1596	4	11	88-89	120-121	42																																																																				
B (NA) 4	79 x 81,4	1596	4	11	88-89	120-121	42																																																																				
B (A) 4	79 x 81,4	1596	4	11	90	122	42																																																																				
B (LA) 5	83 x 93,2	2522	4	9	166	225	76																																																																				
B (LA) 5	83 x 93,2	2521	4		147	200	76																																																																				
B (LA) 5	83 x 93,2	2521	4	9	147	200	76																																																																				
B (NA) 4	79 x 81,4	1596	4	11	77	105	43																																																																				
B (NA) 4	79 x 81,4	1596	4	11	77	105	43																																																																				
D (LA) 4	107 x 124	4500	4	17,3:1	99-154	133-207	152																																																																				
D (A) 6	107 x 124	6700	4	17,3:1	150-242	200-325	153																																																																				
D (A) 6	114 x 135	8270	2	17,5:1	238	319	158																																																																				
D (LA) 6	114 x 145	8900	4	16,9:1	205-279	330-449	157																																																																				
B (NA) 4	81 x 63	1298	2	9,2	40	54	62																																																																				
B (NA) 4	81 x 63	1298	2	9,2	40	54	62																																																																				
B (NA) 4	81 x 63	1298	2	9,2	38-47	52-64	61																																																																				
B (NA) 4	79 x 66	1297	2	9,5	40-43	55-58	38																																																																				
B (NA) 4	79 x 66	1294	2		44	60	39																																																																				
B (NA) 4	73,96 x 75,48	1297	2	9,3	44	60	17																																																																				
B (NA) 4	80 x 64,5	1296	2	9,5	51	69	50																																																																				
B (NA) 4	80 x 64,5	1297	2	9,5	51	69	50																																																																				
B (A) 4	79 x 81,4	1596	4	10	110	150	43																																																																				
B (A) 4	79 x 81,4	1596	4	10	110	150	43																																																																				
B (A) 4	79 x 81,4	1596	4	10	110	150	43																																																																				
B (A) 4	79 x 81,4	1596	4	10	110	150	43																																																																				
B (A) 4	79 x 81,4	1596	4		118	160	43																																																																				
B (A) 4	79 x 81,4	1596	4		118	160	43																																																																				
B (A) 4	79 x 81,4	1596	4	10	134	182	43																																																																				
B (A) 4	79 x 81,4	1596	4	10	134	182	43																																																																				
B (A) 4	79 x 81,4	1596	4	10	134	182	43																																																																				
B (A) 4	79 x 81,4	1596	4	10	134	182	43																																																																				
B (A) 4	79 x 81,4	1596	4	10	134	182	43																																																																				
B (A) 4	79 x 81,4	1596	4	10	130-134	179-182	43																																																																				
B (A) 4	79 x 81,4	1596	4	10	118	160	43																																																																				
B (A) 4	79 x 81,4	1596	4	10	118	160	43																																																																				
D (LA) 4	89,9 x 94,6	2402	4	18	85	115	127																																																																				
D (LA) 4	89,9 x 94,6	2402	4	18	85	115	127																																																																				
D (LA) 4	82,5 x 82	1753	2		92	125	73																																																																				
D (LA) 4	82,5 x 82	1753	2	17	85	115	73																																																																				
D (LA) 4	82,5 x 82	1753	2	17	85	115	73																																																																				
D (LA) 4	85 x 88	1997	4	18	85	116	87																																																																				
D (LA) 4	85 x 88	1997	4		85	115	87																																																																				
D (LA) 4	85 x 96	2179	4		147	200	96																																																																				
D (LA) 4	85 x 96	2179	4		146	199	96																																																																				
D (LA) 4	85 x 96	2179	4		147	200	95																																																																				
D (LA) 4	85 x 96	2179	4		146	199	98																																																																				
D (LA) 4	73,7 x 82	1399	2	17,9	50-51	68-69	14																																																																				
B (NA) 4	76 x 88	1597	4	10,3	66	90	28																																																																				
B (NA) 4	76 x 88	1597	4	10,3	66	90	28																																																																				
B (NA) 4	76 x 88	1597	4	10,3	65-66	88-90	28																																																																				
B (NA) 4	76 x 88	1597	4	10,3	65	88	30																																																																				
B (NA) 4	76 x 88	1597	4	10,3	65-66	88-90	28																																																																				
B (NA) 4	76 x 88	1597	4	10,3	66-70	90-95	29																																																																				
B (NA) 4	76 x 88	1597	4	10,3	70	95	29																																																																				
B (NA) 4	76 x 88	1597	4	10,3	70	95	29																																																																				
B (NA) 4	76 x 88	1597	4	10,3	70	95	29																																																																				
B (NA) 4	79 x 81,4	1596	4	11	76	103	41																																																																				
B (NA) 4	79 x 81,4	1596	4	11	70-76	95-103	41																																																																				
B (NA) 4	80,98 x 77,6	1598	2	9	62-71	84-97	60																																																																				
B (NA) 4	80 x 79,5	1598	2	8,5	66	90	51																																																																				
B (NA) 4	80 x 79,5	1598	2	9,1	59	80	53																																																																				
B (NA) 4	81 x 77,6	1598	2	9,5	53-62	72-84	61																																																																				
B (NA) 6	82,4 x 79,5	2544	4	9,2	125	170	68																																																																				
B (NA) 6	81,6 x 79,5	2495	4	9,2	125	170	67																																																																				
B (NA) 6	81,6 x 79,5	2495	4	9,2	125	170	67																																																																				
B (NA) 6	81,6 x 79,5	2495	4	9,8	125	170	67																																																																				
B (NA) 6	81,6 x 79,5	2495	4	9,2	125	170	67																																																																				
B (NA) 4	87,68 x 66	1593	2	9,2	53	72	117																																																																				
B (NA) 4	87,65 x 66	1593	2	9,2	54	73	116																																																																				

		Cyl.	mm	cm <sup>3</sup>		Comp. Ratio $\epsilon$	kW	PS	Pos
LCR	B (NA)	4	87,7 x 66	1598	2	9,5:1	54	73	119
LCS	B (NA)	4	81,3 x 77	1593	2	9,5	55	75	66
LCT	B (NA)	4	81,3 x 77	1593	2	9,5	55	75	66
LHA	B (A)	4	80 x 79,5	1598	2	8,2	96-98	131-133	51
LJB	B (NA)	4	80 x 79,5	1597	2	9,75	75	102	51
LJC	B (NA)	4	80 x 79,5	1597	2	9,75	81	110	51
LJD	B (NA)	4	80 x 79,5	1598	2	9,75	76	103	51
LJE	B (NA)	4	80 x 79,5	1598	2	9,75:1	79	108	55
LJF	B (NA)	4	79,96 x 79,52	1598	2	9,75	77	105	48
LNA	B (LA)	4	79,96 x 79,52	1597	2	8,2	97	132	48
LNB	B (LA)	4	79,96 x 79,52	1597	2	8,2	97	132	48
LP1	B (NA)	4	80 x 79,5	1597	2	9,5	52-58	71-79	50
LP2	B (NA)	4	80 x 79,5	1597	2	9,5	58	79	50
LP3	B (NA)	4	80 x 79,5	1597	2	9,5	58	79	50
LPA	B (NA)	4	80 x 79,5	1597	2	9,5	58	79	50
LPBA	D (LA)	4	85 x 88	1997	4	18	85	115	87
LR1	B (NA)	4	80 x 79,5	1597	2	9,5	77	105	51
LR2	B (NA)	4	80 x 79,5	1597	2	9,5	77	105	51
LRA	B (NA)	4	80 x 79,5	1597	2	9,5	77	105	51
LRB	B (NA)	4	80 x 79,5	1597	2	9,5	77	105	51
LSD	B (NA)	4	81,3 x 76,9	1597	2	9,5	55-58	75-79	66
LSDA	B (NA)	4	81,3 x 76,9	1597	2	9,5	51	69	66
LSE	B (NA)	4	81,3 x 76,9	1597	2	9,5	55	75	66
LSF	B (NA)	4	81,3 x 76,9	1597	2	9,5	53	72	66
LTA	D (NA)	4	80 x 80	1608	2	21,5	40	54	56
LTB	D (NA)	4	80 x 80	1608	2	21,5	40	54	56
LTC	D (NA)	4	80 x 80	1608	2	21,5	40	54	56
LUA	B (NA)	4	80 x 79,5	1597	2	9,5	71	96	50
LUAE	B (NA)	4	80 x 79,5	1597	2	9,5	85	115	50
LUB	B (NA)	4	80 x 79,5	1597	2	9,5	70-71	95-97	50
LUC	B (NA)	4	80 x 79,5	1597	2	9,5	60-66	81-90	50
LUD	B (NA)	4	80 x 79,5	1597	2	9,5	70	95	51
LUG	B (NA)	4	80 x 79,5	1597	2	8,5	65-66	88-90	50
LUH	B (NA)	4	76 x 88	1597	2	10,3	65-66	88-90	27
LUJ	B (NA)	4	80 x 79,5	1598	2	9,5	65-66	88-90	54
LUK	B (NA)	4	80 x 79,5	1598	2	9,5	65-66	88-90	50
LXD 2	D	4	94 x 83	2304	2	23:1	49	67	143
M0JA Euro 6	B (A)	3	71,9 x 82	999	4		70	95	10
M1CA	B (A)	3	71,9 x 81,9	998	4	10	92	125	8
M1CB	B (A)	3	71,9 x 81,9	998	4	10	92	125	8
M1DA Euro 5	B (A)	3	71,9 x 81,9	998	4	10	92	125	9
M1DC	B (A)	3	71,9 x 81,9	998	4	10	92	125	9
M1DD Euro 6	B (A)	3	71,9 x 81,9	998	4	10	92	125	9
M1DH	B (A)	3	71,9 x 81,9	998	4	10	103	140	8
M1JA	B (A)	3	71,9 x 81,9	998	4	10	88	120	8
M1JC Euro 5	B (A)	3	71,9 x 81,9	998	4	9,9	92	125	8
M1JE	B (A)	3	71,9 x 81,9	998	4	10	92	125	8
M1JH	B (A)	3	71,9 x 81,9	998	4	10	92	125	8
M1JJ Euro 6	B (A)	3	71,9 x 81,9	998	4	9,9	92	125	8
M1JL Euro 5	B (A)	3	71,9 x 81,9	998	4	10	92	125	8
M1JM Euro 6	B (A)	3	71,9 x 81,9	998	4	10	92	125	8
M1JU Euro 5	B (A)	3	71,9 x 81,9	998	4	9,9	92	125	8
M2DA Euro 5	B (A)	3	71,9 x 81,9	998	4	10	74	100	8
M2DB	B (A)	3	71,9 x 81,9	998	4	10	74	100	8
M2DC Euro 6	B (A)	3	71,9 x 81,9	998	4	10	74	100	8
M2GA Euro 5	B (A)	3	71,9 x 81,9	998	4	10	74	100	8
M2GB Euro 6	B (A)	3	71,9 x 81,9	998	4	10	74	100	8
M7JA	B (NA)	4	71,9 x 76,5	1242	4	10:1	51	70	7
M7JB	B (NA)	4	71,9 x 76,5	1242	4	10:1	51	70	7
M8DA	B (A)	4	79 x 76,4	1498	4	10	110	150	43
M8DB	B (A)	4	79 x 76,4	1498	4	10	110	150	43
M8MA	B (A)	4	79 x 76,4	1499	4	10	110	150	43
M9DA	B (A)	4	79 x 76,4	1498	4	10	132-134	179-182	43
M9DB	B (A)	4	79 x 76,4	1498	4	10	132-134	179-182	43
MC	B	4	90,83 x 76,95	1993	2	8,5:1	75	101	134
MTDA	D (LA)	4	75 x 88,3	1560	4		74	100	22
MY	B (NA)	4	90 x 66,8	1699	2	8,75:1	51-55	69-75	129
MYE	B (NA)	4	90 x 66,8	1699	2	8,75:1	54	74	129
N4A	B (NA)	4	90,83 x 77	1993	2	9,2	85	115	135

F





	Cyl.	Cyl. Diagram	mm	cm <sup>3</sup>	Cyl. Diagram	Comp.	kW	PS	Pos
						Ratio			
N4B	B (NA) 4		90,8 x 77	1993	2	8,5	74	100	131
N4I	B (NA) 4		90,83 x 77	1993	2	9,2	85	115	135
N4JB	B (NA) 4		87,5 x 83,1	1999	4	10,8	110	150	115
N6T	B (NA) 4		90,8 x 77	1993	2	8,6:1	57	78	132
N7A	B (NA) 4		86 x 86	1998	4	10,3	110	150	102
N7BA	D (A) 4		86 x 86	1998	4	18,2	96	130	104
N7BB	D (LA) 4		86 x 86	1998	4	18:1	96	131	106
N8A	B (NA) 4		86 x 86	1998	2	10,3	80	109	100
N8C	B (NA) 4		86 x 86	1993	2	10,3	77	105	100
N8D	B (NA) 4		86 x 86	1993	2	10,3	77	105	100
N9A	B (NA) 4		86 x 86	1998	2	10,3	90	122	101
N9B	B (NA) 4		86 x 86	1998	2	10,3	92	125	101
N9C	B (NA) 4		86 x 86	1998	2	10,3	88-92	120-125	101
N9D	B (NA) 4		86 x 86	1998	2	10,3	88	120	101
N9F	B (NA) 4		86 x 86	1998	2	10,3	85	115	101
NAE	B (NA) 4		90,83 x 76,95	1993	2	8	57	78	137
NAT	B (NA) 4		90,8 x 76,95	1994	2	8	57	78	132
NAV	B (NA) 4		90,83 x 76,95	1994	2	8	55-57	75-78	134
NBA	B (NA) 4		90,8 x 77	1993	2	8,5:1	66	90	132
NCA	B (NA) 4		90,8 x 77	1994	2	8,5:1	72	98	133
ND	D 3		106,698 x 106,68	2870	2	16,5:1	32-35	44-47	151
NE	B (NA) 4		90,8 x 77	1993	2	9,2	73-80	99-110	130
NE5	B (NA) 4		90,8 x 77	1993	2	9,2	74	100	131
NEE	B (NA) 4		90,8 x 77	1993	2	9,2	72	98	131
NEG	B (NA) 4		90,8 x 77	1993	2	9,2	70-73	95-99	131
NEJ	B (NA) 4		90,8 x 77	1993	2	9,2	74	100	131
NEK	B (NA) 4		90,83 x 77	1993	2	9,2	74-77	101-105	136
NEL	B (NA) 4		90,83 x 77	1993	2	9,2	77	105	135
NEN	B (NA) 4		90,83 x 77	1993	2	9,2	73-74	99-101	135
NEP	B (NA) 4		90,83 x 77	1993	2	9,2	74-77	101-105	135
NER	B (NA) 4		90,83 x 77	1993	2	9,2	64-74	100	135
NES	B (NA) 4		90,8 x 77	1993	2	10,3	77	105	131
NET	B (NA) 4		90,83 x 77	1993	2	9,2	74-77	101-105	135
NGA	B (NA) 4		84,8 x 88	1988	4	10	96-100	131-136	84
NGB	B (NA) 4		84,8 x 88	1988	4	10	96	131	85
NGC	B (NA) 4		84,8 x 88	1988	4	10	96	131	84
NGCA	D (A) 4		75 x 88,3	1560	2	16	85	115	26
NGD	B (NA) 4		84,8 x 88	1988	4	10	96	131	84
NGDA	D (LA) 4		75	1560	2		77	105	25
NR2	B (NA) 4		90,83 x 77	1993	2	9,2	85	115	135
NRA	B (NA) 4		90,83 x 77	1993	2	9,2	85	115	135
NRB	B (NA) 4		90,83 x 77	1993	2	9,2	85	115	135
NRC	B (NA) 4		90,83 x 77	1993	2	8,5	74	100	135
NRD	B (NA) 4		90,83 x 77	1993	2	8,5	74	100	135
NRI	B (NA) 4		90,83 x 77	1993	2	9,2	85	115	135
NSD	B (NA) 4		86 x 86	1998	2	9,8	85	115	101
NSE	B (NA) 4		86 x 86	1998	2	9,8	85	116	101
NSF	B (NA) 4		86 x 86	1998	2	9,8	84	114	101
NSG	B (NA) 4		86 x 86	1998	2	9,8	84	114	101
NSH KAT	BG (NA) 4		86 x 86	1998	2	9,5	74-84	101-114	99
NWN	B 6		84 x 60,1	1999	2	8,75	66	90	78
NWR	B (NA) 6		84 x 60,1	1999	2	8,2	66	90	78
NYL	B 6		84 x 60,1	1999	2	8,75:1	66	90	78
NYP	B 6		84 x 60,1	1998	2	8,75:1	66	90	78
NYR	B (NA) 6		84 x 60,1	1999	2	8,75	66	90	78
NYT	B (NA) 6		84 x 60,1	1999	2	9	66	90	78
OM 352.937	D (A) 6		97 x 128	5675	2	16:1	110	150	145
P4JA	B (NA) 3		71,9 x 81,9	998	4	12	59-63	80-86	8
P4JB	B (NA) 3		71,9 x 81,9	998	4	12	59	80	8
P4JC	B (NA) 3		71,9 x 81,9	998	4	12	59	80	8
P4JD	B (NA) 3		71,9 x 81,9	998	4	12	59	80	8
P7PA	D (A) 4		82,5 x 82	1753	2		55	75	73
P7PB	D (A) 4		82,5 x 82	1753	2		55	75	74
P8FA Euro 4	D (A) 4		86 x 94,6	2198	4	17,5	63	85	107
P8FB Euro 4	D (A) 4		86 x 94,6	2198	4	17,5	63	85	107
PGFA Euro 4	D (LA) 4		86 x 94,6	2198	4	15,5	103	140	107
PGFB	D (LA) 4		86 x 94,6	2198	4	15,5	103	140	107
PHFA Euro 4	D (LA) 4		89,9 x 94,6	2402	4	18	74	100	127
PHFC Euro 4	D (LA) 4		89,9 x 94,6	2402	4	18	74	100	127

		Cyl.		mm	cm <sup>3</sup>		Comp. Ratio $\epsilon$	kW	PS	Pos
PNBA	B (NA)	4		79 x 81,4	1596	4	11	92	125	42
Q4BA Euro 4	D (LA)	4		85 x 96	2179	4	16,6	129	175	90
Q4WA Euro 4	D (LA)	4		85 x 96	2179	4	16,6	129	175	91
QJBA	D (LA)	4		86 x 94,6	2198	4	17,5	114	155	104
QJBB	D (LA)	4		86 x 94,6	2198	4	17,5	114	155	104
QJBC	D (LA)	4		86 x 94,6	2198	4	17,5	110	150	104
QJBD	D (LA)	4		86 x 94,6	2198	4	17,5	110	150	104
QQDA	B (NA)	4		83 x 83,1	1798	4	10,8:1	92	125	75
QQDB	B (NA)	4		83 x 83,1	1798	4	10,8:1	92	125	75
QQDC	B (NA)	4		83 x 83,1	1798	4	10,8:1	90	122	75
QVFA Euro 4	D (A)	4		86 x 94,6	2198	4	17,5	81	110	107
QWFA Euro 4	D (A)	4		86 x 94,6	2198	4	17,5	96	130	107
QXBA Euro 4	D (LA)	4		85 x 88	1997	4	18	103	140	87
QXBB Euro 4	D (LA)	4		85 x 88	1997	4	18	103	140	87
QXWA	D (LA)	4		85 x 88	1997	4	17,9	103	140	87
QXWB Euro 4	D (LA)	4		85 x 88	1997	4	17,9	103	140	87
QXWC Euro 4	D (LA)	4		85 x 88	1997	4	17,9	103	140	88
QYBA	D (LA)	4		82,5 x 82	1753	2		92	125	73
QYWA	D (LA)	4		82,5 x 82	1753	2		92	125	73
R2A	B (NA)	4		86,2 x 77	1796	2	9,5	66	90	114
R2C	B (NA)	4		80 x 88	1769	2	9,3	64	87	52
R2PA	D (A)	4		82,5 x 82	1753	2		55	75	73
R3PA	D (LA)	4		82,5 x 82	1753	2		66	90	74
R6A	B (NA)	4		80 x 88	1769	2	9,3	64-66	87-90	52
RD	D	4		106,698 x 106,68	3815	2	16,5:1	46-50	62-68	151
RDA	B (NA)	4		80,6 x 88	1796	4	10	77	105	57
RDB	B (NA)	4		80,6 x 88	1796	4	10	77	105	57
REB	B (NA)	4		86,2 x 77	1796	2	9,5	66	90	113
REC	B (NA)	4		86,2 x 77	1796	2	9,5	66	90	113
RED	B (NA)	4		86,2 x 77	1796	2	9,5	59-66	80-90	113
REF	B (NA)	4		86,2 x 77	1796	2	9,5	59	80	113
RF	D (NA)	4		86 x 86	1998	2	22,7	41-55	56-75	103
RFA	D (A)	4		82,5 x 82	1753	2	21,5	55-57	75-78	69
RFB	D (A)	4		82,5 x 82	1753	2	21,5	55-57	75-78	69
RFD	D (LA)	4		82,5 x 82	1753	2	21,5	66	90	69
RFK	D (LA)	4		82,5 x 82	1753	2	21,5	66	90	69
RFL	D (A)	4		82,5 x 82	1753	2	21,5	55-57	75-78	69
RFM	D (LA)	4		82,5 x 82	1753	2	21,5	65-66	88-90	69
RFN	D (LA)	4		82,5 x 82	1753	2	21,5	65-66	88-90	69
RFS KAT	D (LA)	4		82,5 x 82	1753	2	21,5	66	90	71
RFU	D (A)	4		82,5 x 82	1753	2	21,5:1	57	78	69
RHBA	B (NA)	4		79 x 81,4	1596	4	11	81	110	42
RKA	B (NA)	4		80,6 x 88	1796	4	10	85	115	58
RKB	B (NA)	4		80,6 x 88	1796	4	10	82-85	111-116	58
RKC	B (NA)	4		80,6 x 88	1796	4	9,8	85	115	57
RKF	B (NA)	4		80,6 x 88	1796	4	10	85	115	57
RKH	B (NA)	4		80,6 x 88	1796	4	10	85	115	57
RKJ	B (NA)	4		80,6 x 88	1796	4	10	85	115	57
RKK	B (NA)	4		80,6 x 88	1796	4	10	85	115	58
ROB	B (NA)	4		80,6 x 88	1796	4	10	96	130	57
ROC	B (NA)	4		80,6 x 88	1796	4	10	96	130	57
RTA	D (NA)	4		82,5 x 82	1753	2	21,5	44	60	70
RTB	D (NA)	4		82,5 x 82	1753	2	21,5	44	60	70
RTC	D (NA)	4		82,5 x 82	1753	2	21,5	43-44	58-60	70
RTD	D (NA)	4		82,5 x 82	1753	2	21,5	43-44	58-60	70
RTE	D (NA)	4		82,5 x 82	1753	2	21,5	44	60	70
RTF	D (NA)	4		82,5 x 82	1753	2	21,5	44	60	70
RTG	D (NA)	4		82,5 x 82	1753	2	21,5	43-44	58-60	70
RTH	D (NA)	4		82,5 x 82	1753	2	21,5	44	60	70
RTJ	D (NA)	4		82,5 x 82	1753	2	21,5	44	60	70
RTK	D (NA)	4		82,5 x 82	1753	2	21,5	44	60	70
RTN	D (LA)	4		82,5 x 82	1753	2	19,4	55-57	75-78	73
RTP	D (LA)	4		82,5 x 82	1753	2	19,4	55-57	75-78	73
RTQ	D (LA)	4		82,5 x 82	1753	2	19,4	55-57	75-78	73
RVA	D (A)	4		82,5 x 82	1753	2	21,5	51	70	72
RWPA	D (LA)	4		82,5 x 82	1753	2		81	110	73
RWPC	D (LA)	4		82,5 x 82	1753	2		81	110	74
RWPD	D (LA)	4		82,5 x 82	1753	2		81	110	74
RWPE	D (LA)	4		82,5 x 82	1753	2		66	90	74

F

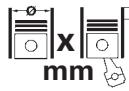
	Cyl.	Cyl. Diagram	Cyl. Diagram	cm <sup>3</sup>	Comp. Ratio	kW	PS	Pos
RWPF	D (LA) 4	82,5 x 82	1753	2		66	90	74
SAFA	D (LA) 5	89,9 x 100,76	3198	4	15,7	147	200	128
SAFB	D (LA) 5	89,9 x 100,76	3199	4		147	200	128
SDBA	D (A) 4	86 x 86	1998	4	19,5	66	90	104
SEBA	B (NA) 4	87,5 x 94	2261	4		118	160	115
SFA	D (A) 4	94 x 90	2498	2	21	68	92	144
SFB	D (A) 4	94 x 90	2498	2	21	68	92	144
SFCA	B (A) 3	71,9 x 81,9	998	4	10,5	74	100	8
SFCB	B (A) 3	71,9 x 81,9	998	4	10,5	74	100	8
SFCC	B (A) 3	71,9 x 81,9	998	4	10,5	74	100	8
SFCD	B (A) 3	71,9 x 81,9	998	4	10,5	74	100	8
SFDA Euro 5	B (A) 3	71,9 x 81,9	998	4	10,5	74	100	8
SFDB	B (A) 3	71,9 x 81,9	998	4	10,5	74	100	8
SFDC Euro 6	B (A) 3	71,9 x 81,9	998	4	10-10,5	63	85	8
SFJA	B (A) 3	71,9 x 81,9	998	4	10,5	74	101	9
SFJB	B (A) 3	71,9 x 81,9	998	4	10,5	74	101	9
SFJC	B (A) 3	71,9 x 81,9	998	4	10,5	74	100	9
SFJD	B (A) 3	71,9 x 81,9	998	4	10	74	100	9
SFJE Euro 6	B (A) 3	71,9 x 81,9	998	4	10,5	74	101	8
SFJF Euro 5	B (A) 3	71,9 x 81,9	998	4	10	74	101	8
SFJH Euro 6	B (A) 3	71,9 x 81,9	998	4	10	74	101	8
SFJJ Euro 5	B (A) 3	71,9 x 81,9	998	4	10	74	101	8
SFJK Euro 6	B (A) 3	71,9 x 81,9	998	4	10,5	74	101	8
SFJL Euro 6	B (A) 3	71,9 x 81,9	998	4	10-10,5	74	100	8
SFJN Euro 6	B (A) 3	71,9 x 81,9	998	4	10-10,5	74	101	8
SFJP Euro 6	B (A) 3	71,9 x 81,9	998	4	10-10,5	74	101	8
SHDA	B (NA) 4	79 x 81,4	1596	4	11:1	74	101	42
SHDB	B (NA) 4	79 x 81,4	1596	4	11:1	74	101	42
SHDC	B (NA) 4	79 x 81,4	1596	4	11:1	74	101	42
SNJA	B (NA) 4	71,9 x 76,5	1242	4	11	60	82	7
SNJB	B (NA) 4	71,9 x 76,5	1242	4	11	60	82	7
SPJA	B (NA) 4	76 x 76,5	1388	4		71	97	32
SPJC	B (NA) 4	76 x 76,5	1388	4		71	97	32
SRFA	D (LA) 4	86 x 94,6	2198	4	17,5	85	115	107
SRFB	D (LA) 4	86 x 94,6	2198	4	17,5	85	115	107
SRFC	D (LA) 4	86 x 94,6	2198	4	17,5	85	115	107
SRFD	D (LA) 4	86 x 94,6	2198	4	17,5	85	115	107
SRFE	D (LA) 4	86 x 94,6	2198	4	17,5	85	115	107
STP	D (NA) 4	94 x 90	2499	2	23	51	69	144
STR	D (NA) 4	94 x 90	2498	2	23	51	69	144
SYDA	B (NA) 4	87,5 x 83,1	1999	4	10,8:1	104-109	143-146	115
T1BA	D (LA) 4	75 x 88,3	1560	2	16,0:1	85	116	23
T1BB	D (LA) 4	75 x 88,3	1560	2	16,0:1	85	116	23
T1BC	D (LA) 4	75 x 88,3	1560	2	16,0:1	85	115	23
T1DA	D (LA) 4	75 x 88,3	1560	2	16	85	115	23
T1DB	D (LA) 4	75 x 88,3	1560	2	16	85	115	23
T1WA	D (LA) 4	75 x 88,3	1560	2		85	115	25
T1WB	D (LA) 4	75 x 88,3	1560	2	16	85	115	25
T3CA	D (A) 4	75 x 88,3	1560	2		70	95	25
T3CB	D (A) 4	75 x 88,3	1560	2		70	95	26
T3CC	D (LA) 4	75 x 88,3	1560	2		70	95	26
T3DA	D (LA) 4	75 x 88,3	1560	2	16,0:1	70	95	23
T3DB	D (LA) 4	75 x 88,3	1560	2	16,0:1	70	95	23
T3JA	D (A) 4	75 x 88,3	1560	2		70	95	24
T3JB	D (A) 4	75 x 88,3	1560	2		70	95	26
T7CE	D (LA) 4	85 x 88	1998	4	17	110	150	96
T7CJ	D (LA) 4	85 x 88	1997	4		110	150	96
T7CK	D (LA) 4	85 x 88	1997	4		110	150	96
T7CL	D (LA) 4	85 x 88	1997	4		110	150	96
T7DB	D (LA) 4	85 x 88	1997	4	17	110	150	96
T7MA	D (LA) 4	85 x 88	1997	4	16,7	110	150	96
T7MB	D (LA) 4	85 x 88	1997	4	16,7	110	150	96
T8CC	D (LA) 4	85 x 88	1997	4	17	132	180	96
T8CD	D (LA) 4	85 x 88	1997	4	17	132	180	96
T8CH	D (LA) 4	85 x 88	1997	4		132	180	96
T8CI	D (LA) 4	85 x 88	1997	4		132	180	96
T8CJ	D (LA) 4	85 x 88	1997	4		132	180	96
T8CL	D (LA) 4	85 x 88	1997	4	17	132	180	96
T8DA	D (LA) 4	85 x 88	1997	4		136	185	96

		Cyl.	 mm	cm <sup>3</sup>		Comp. Ratio $\epsilon$	kW	PS	Pos
T8DE	D (LA)	4	85 x 88	1997	4	17	125	170	96
T8MA	D (LA)	4	85 x 88	1997	4	16,7	132	180	96
T8MB	D (LA)	4	85 x 88	1997	4	16,7	132	180	96
T9CA	D (LA)	4	85 x 88	1997	4	16,7	154	210	96
T9CB	D (LA)	4	85 x 88	1997	4		154	210	96
T9CC	D (LA)	4	85 x 88	1997	4		154	210	96
TBBA Euro 4	B (NA)	4	87,5 x 83,1	1999	4	10,8	107	145	115
TBBB	B (NA)	4	87,5 x 83,1	1999	4		107	145	115
TXBA	D (LA)	4	85 x 88	1997	4		120	163	93
TXBB	D (LA)	4	85 x 88	1997	4		120	163	93
TXDA	D (LA)	4	85 x 88	1997	4		118-120	160-163	92
TXDB	D (LA)	4	85 x 88	1997	4		120	163	94
TXMA	D (LA)	4	85 x 88	1997	4	16	120	163	93
TXWA	D (LA)	4	85 x 88	1997	4		118-120	160-163	93
TYBA	D (LA)	4	85 x 88	1997	4	18	85	115	89
TYDA	D (LA)	4	85 x 88	1997	4		85	116	94
TZJA	D (A)	4	75 x 88,3	1560	2		70	95	23
TZJB	D (A)	4	75 x 88,3	1560	2		70	95	23
U3CA	D (A)	4	75 x 88,3	1560	2	16	85	115	26
UBJA	D (A)	4	75 x 88,3	1560	4		55	75	22
UFCA	D (LA)	4	85 x 88	1997	4		88	120	96
UFCB	D (LA)	4	85 x 88	1997	4		88	120	96
UFDA	D (LA)	4	85 x 88	1997	4		103	140	92
UFDB	D (LA)	4	85 x 88	1997	4		103	140	94
UGCA	D (A)	4	73,5 x 88,3	1499	2	16	55	75	12
UGCB	D (A)	4	73,5 x 88,3	1499	2		55	75	11
UGCC	D (LA)	4	73,5 x 88,3	1499	2		88	120	11
UGJC	D (A)	4	73,5 x 88,3	1499	2		55	75	12
UGJE	D (A)	4	73,5 x 88,3	1499	2		66-67	90-91	11
UGJG	D (A)	4	73,5 x 88,3	1499	2		55	75	11
UGJM	D (A)	4	73,5 x 88,3	1499	2		74	100	11
UHFA	D (LA)	4	86 x 94,6	2198	4	15,5	103	140	108
UHFB	D (LA)	4	86 x 94,6	2198	4	15,5	103	140	108
UHFC	D (LA)	4	86 x 94,6	2198	4	15,5	103	140	109
UHR5	D (LA)	4	86 x 94,6	2198	4	15,5	99	135	111
UKDA	D (LA)	4	85 x 88	1997	4	18	100	136	92
UKDB	D (LA)	4	85 x 88	1997	4		100	136	94
UNCA Euro 6	B (LA)	4	79 x 76,4	1499	4	10	118	160	43
UNCB Euro 6	B (LA)	4	79 x 76,4	1499	4	10	118	160	43
UNCE Euro 6	B (LA)	4	79 x 76,4	1499	4	10	118	160	43
UNCF Euro 6	B (LA)	4	79 x 76,4	1499	4	10,1	118	160	43
USF6	D (LA)	4	86 x 94,6	2198	4	15,5	92	125	109
USR6	D (LA)	4	86 x 94,6	2198	4	15,5	92	125	111
USRA	D (LA)	4	86 x 94,6	2198	4	15,5	100	136	111
USRB	D (LA)	4	86 x 94,6	2198	4	15,5	100	136	111
UYR6	D (LA)	4	86 x 94,6	2198	4	15,5	114	155	111
VTA	D	4	88 x 80	1948	2	21,8:1	37	50	120
XMJA	B (A)	3	71,9 x 81,9	998	4	12	48	65	8
XMJB	B (A)	3	71,9 x 81,9	998	4	12	48	65	8
XUCA	D (LA)	4	73,5 x 88,3	1499	2	16	88	120	11
XUCC	D (LA)	4	73,5 x 88,3	1499	2	16	55	75	11
XUCD	D (LA)	4	73,5 x 88,3	1499	2	16	55	75	11
XUJA Euro 6	D (LA)	4	73,5 x 88,3	1499	2	16	55	75	11
XUJB Euro 6	D (LA)	4	73,5 x 88,3	1499	2	16	55	75	11
XUJC Euro 6	D (LA)	4	73,5 x 88,3	1499	2	16	63	86	11
XUJD Euro 5	D (LA)	4	73,5 x 88,3	1499	2	16	63	86	11
XUJE Euro 5	D (LA)	4	73,5 x 88,3	1499	2	16	63	86	11
XUJF Euro 6	D (LA)	4	73,5 x 88,3	1499	2	16	63	86	11
XUJG Euro 6	D (LA)	4	73,5 x 88,3	1499	2	16	63	86	11
XUJH Euro 6	D (LA)	4	73,5 x 88,3	1499	2		74	100	11
XUJK Euro 6	D (LA)	4	73,5 x 88,3	1499	2	16	63	86	11
XUJL Euro 6	D (LA)	4	73,5 x 88,3	1499	2	16	63	86	11
XUJM Euro 6	D (LA)	4	73,5 x 88,3	1499	2	16	63	86	11
XUJN Euro 6	D (LA)	4	73,5 x 88,3	1499	2	16	63	86	11
XVCA	D (LA)	4	73,5 x 88,3	1499	2	16	70	95	11
XVCB	D (LA)	4	73,5 x 88,3	1499	2	16	70	95	11
XVCC	D (LA)	4	73,5 x 88,3	1499	2	16	70	95	11
XVGA Euro 6	D (A)	4	73,5 x 88,3	1499	2	16	74	101	11
XVGB Euro 6	D (A)	4	73,5 x 88,3	1499	2	16	74	101	11

**F**

Cyl.	mm	cm <sup>3</sup>	Comp. Ratio	kW	PS	Pos
XVGC Euro 6	D (A) 4	73,5 x 88,3	1499 2	16	74	101 11
XVJA	D (LA) 4	73,5 x 88,3	1499 2	16	70	95 11
XVJB	D (LA) 4	73,5 x 88,3	1499 2	16	70	95 11
XVJC	D (LA) 4	73,5 x 88,3	1499 2	16	70	95 11
XVJD	D (A) 4	73,5 x 88,3	1499 2	16	70	95 11
XVJE Euro 6	D (LA) 4	73,5 x 88,3	1499 2	16	63	86 11
XWCA Euro 6	D (LA) 4	73,5 x 88,3	1499 2	16	55	75 11
XWCB Euro 6	D (LA) 4	73,5 x 88,3	1499 2	16	55	75 11
XWDA	D (LA) 4	73,5 x 88,3	1499 2	16,1	88	120 12
XWDB	D (LA) 4	73,5 x 88,3	1499 2	16,1	88	120 12
XWDC	D (LA) 4	73,5 x 88,3	1499 2	16,1	88	120 12
XWDD	D (LA) 4	73,5 x 88,3	1499 2	16,1	88	120 12
XWDE	D (LA) 4	73,5 x 88,3	1499 2	16,1	88	120 11
XWGA Euro 6	D (A) 4	73,5 x 88,3	1499 2		88	120 11
XWGB Euro 6	D (A) 4	73,5 x 88,3	1499 2		88	120 11
XWGC Euro 4	D (A) 4	73,5 x 88,3	1499 2		88	120 11
XWJA Euro 5	D (LA) 4	73,5 x 88,3	1499 2	16	88	120 11
XWJB Euro 6	D (LA) 4	73,5 x 88,3	1499 2	16	88	120 11
XWJC Euro 6	D (LA) 4	73,5 x 88,3	1499 2	16	88	120 11
XWMB Euro 6	D (LA) 4	73,5 x 88,3	1499 2	16	88	120 11
XWMC Euro 6	D (LA) 4	73,5 x 88,3	1499 2	16	88	120 11
XXCA	D (LA) 4	73,5 x 88,3	1499 2	16	74	100 11
XXCB	D (LA) 4	73,5 x 88,3	1499 2	16	74	100 11
XXCC	D (LA) 4	73,5 x 88,3	1499 2	16	74	100 11
XXDA	D (LA) 4	73,5 x 88,3	1499 2	16,1	70	95 12
XXDB	D (LA) 4	73,5 x 88,3	1499 2	16,1	77	105 12
XXDC	D (LA) 4	73,5 x 88,3	1499 2	16,1	70	95 12
XXGA Euro 6	D (A) 4	73,5 x 88,3	1499 2		74	101 11
YLDA	D (A) 4	84 x 90	1995 4		110	150 80
YLF6	D (A) 4	84,01 x 90,03	1995 4	16,5	77	105 81
YLFS	D (A) 4	84,01 x 90,03	1995 4	16,5	77	105 81
YMCB	D (A) 4	84 x 90	1995 4		110	150 80
YMF6	D (A) 4	84,01 x 90,03	1995 4	16,5	96	130 81
YMFA Euro 6	D (A) 4	84,01 x 90,03	1995 4		96	130 81
YMFB Euro 6	D (A) 4	84,01 x 90,03	1995 4		96	130 81
YMFS	D (A) 4	84,01 x 90,03	1995 4	16,5	96	130 81
YNCA	D (A) 4	84 x 90	1995 4		88	120 80
YNF6	D (A) 4	84,01 x 90,03	1995 4	16,5	125	170 81
YNFA Euro 6	D (A) 4	84,01 x 90,03	1995 4		125	170 81
YNFB Euro 6	D (A) 4	84,01 x 90,03	1995 4		125	170 81
YNFS	D (A) 4	84,01 x 90,03	1995 4	16,5	125	170 81
YTR	D (NA) 4	94 x 83	2304 2	22,2	49	67 143
YTT	D (NA) 4	94 x 83	2304 2	22,2	49	67 143
YYJA	B (A) 3	71,9 x 81,9	998 4	9,9	103	140 8
YYJB	B (A) 3	71,9 x 81,9	998 4	9,9	103	140 8
YYJC	B (A) 3	71,9 x 81,9	998 4	9,9	103	140 8
YYJD Euro 5	B (A) 3	71,9 x 81,9	998 4	9,9	103	140 8
YYJE Euro 6	B (A) 3	71,9 x 81,9	998 4	9,9	103	140 8
Z2JA Euro 6	D (LA) 4	75 x 84,8	1499 4		74	100 26
ZTJA Euro 6	D (LA) 4	75 x 84,8	1499 4		92	125 26
ZTJB Euro 6	D (LA) 4	75 x 84,8	1499 4		92	125 26
ZTJC Euro 6	D (LA) 4	75 x 84,8	1499 4		92	125 26
ZVSA	B (NA) 4	86 x 86	1998 2	9,8:1	85	116 101



					Pos						Pos	
<b>B-MAX (JK)</b>												
1.0 EcoBoost	10.2012 →	M1JA	B	8	1.6 EcoBoost	12.2010 →	JQDB	B	43			
1.0 EcoBoost	10.2012 →	M1JE	B	8	1.6 EcoBoost	12.2010 →	JTDA	B	43			
1.0 EcoBoost	10.2012 →	M1JH	B	8	1.6 EcoBoost	12.2010 →	JTDB	B	43			
1.0 EcoBoost	10.2012 →	SFJA	B	9	1.6 TDCi	12.2010 →	T1DA	D	23			
1.0 EcoBoost	10.2012 →	SFJB	B	9	1.6 TDCi	12.2010 →	T1DB	D	23			
1.0 EcoBoost	10.2012 →	SFJC	B	9	1.6 TDCi	12.2010 →	T3DA	D	23			
1.0 EcoBoost	10.2012 →	SFJD	B	9	1.6 TDCi	12.2010 →	T3DB	D	23			
1.0 EcoBoost	10.2012 →	YYJC	B	8	1.6 Ti	12.2010 →	IQDB	B	43			
1.5 TDCi	10.2012 →	UGJC	D	12	2.0 TDCi	04.2010 →	UFDB	D	94			
1.5 TDCi	10.2012 →	UGJG	D	11	2.0 TDCi	12.2010 →	TXDB	D	94			
1.5 TDCi	10.2012 →	XUJA	D	11	2.0 TDCi	02.2011 →	TYDA	D	94			
1.5 TDCi	10.2012 →	XUJB	D	11	2.0 TDCi	02.2011 →	UKDB	D	94			
1.5 TDCi	04.2015 →	XVJA	D	11	2.0 TDCi	03.2015 →	T7DB	D	96			
1.5 TDCi	04.2015 →	XVJC	D	11	2.0 TDCi	03.2015 →	T8DE	D	96			
1.6 TDCi	10.2012 →	T3JB	D	26	<b>CAPRI II (GCEP)</b>							
1.6 Ti	10.2012 →	IQJA	B	43	1.3	02.1974 → 08.1977	J1E	B	62			
<b>C-MAX (DM2)</b>					1.3	02.1974 → 08.1977	J1E	B	62			
1.6	02.2007 → 09.2010	HWDA	B	42	1.6	02.1974 → 12.1977	LCE	B	117			
1.6	02.2007 → 09.2010	HWDB	B	42	2.0	04.1976 → 12.1977	NWN	B	78			
1.6	02.2007 → 09.2010	SHDA	B	42	2.0	04.1976 → 12.1977	NYL	B	78			
1.6	02.2007 → 09.2010	SHDB	B	42	<b>CAPRI III (GCEP)</b>							
1.6	02.2007 → 09.2010	SHDC	B	42	1.3	01.1978 → 06.1985	J1E	B	62			
1.6	04.2007 → 09.2010	HXDA	B	42	1.6	01.1978 → 04.1987	LCN	B	116			
1.6	04.2007 → 09.2010	HXDB	B	42	2.0	01.1978 → 12.1982	NYL	B	78			
1.6 TDCi	02.2007 → 09.2010	G8DA	D	22	2.0	01.1978 → 12.1985	NEN	B	135			
1.6 TDCi	02.2007 → 09.2010	G8DB	D	22	<b>CONSUL (GGFL)</b>							
1.6 TDCi	02.2007 → 09.2010	G8DC	D	22	2000	01.1972 → 12.1975	NE	B	130			
1.6 TDCi	02.2007 → 09.2010	G8DD	D	20	<b>CONSUL Coupe (GGCL)</b>							
1.6 TDCi	02.2007 → 09.2010	GPDA	D	22	2000	01.1972 → 12.1975	NE	B	130			
1.6 TDCi	02.2007 → 09.2010	HHDA	D	22	<b>CONSUL Turnier (GGNL)</b>							
1.6 TDCi	02.2007 → 09.2010	HHDB	D	22	2000	01.1972 → 12.1975	NE	B	130			
1.6 TDCi	02.2007 → 09.2010	MTDA	D	22	<b>CORTINA</b>							
1.8	02.2007 → 09.2010	QQDA	B	75	1.6	04.1981 → 1988	LCE	B	117			
1.8	02.2007 → 09.2010	QQDB	B	75	<b>COUGAR (EC_)</b>							
1.8	02.2007 → 09.2010	QQDC	B	75	2.0 16V	08.1998 → 12.2001	EDBA	B	82			
1.8 TDCi	02.2007 → 09.2010	KKDA	D	73	2.0 16V	08.1998 → 12.2001	EDBB	B	82			
1.8 TDCi	02.2007 → 09.2010	KKDB	D	73	2.0 16V	08.1998 → 12.2001	EDBC	B	82			
2.0	02.2007 → 09.2010	AODA	B	115	2.0 16V	08.1998 → 12.2001	EDBD	B	82			
2.0	02.2007 → 09.2010	AODB	B	115	2.5 V6 24V	08.1998 → 12.2001	LCBA	B	68			
2.0	02.2007 → 09.2010	AODE	B	115	2.5 V6 24V	08.1998 → 12.2001	LCBB	B	67			
2.0	02.2007 → 09.2010	SYDA	B	115	2.5 V6 24V	08.1998 → 12.2001	LCBC	B	67			
2.0 CNG	04.2009 → 09.2010	SYDA	B	115	2.5 V6 24V	08.1998 → 12.2001	LCBE	B	67			
2.0 LPG	06.2008 → 09.2010	SYDA	B	115	2.5 V6 24V	06.2000 → 12.2001	LCBB	B	67			
2.0 TDCi	02.2007 → 09.2010	G6DA	D	87	2.5 V6 24V	06.2000 → 12.2001	LCBC	B	67			
2.0 TDCi	02.2007 → 09.2010	G6DB	D	87	2.5 V6 24V	06.2000 → 12.2001	LCBE	B	67			
2.0 TDCi	02.2007 → 09.2010	G6DC	D	87	<b>COURIER Pickup</b>							
2.0 TDCi	02.2007 → 09.2010	G6DD	D	87	1.6	08.2001 → 12.2011	FYDC	B	40			
2.0 TDCi	02.2007 → 09.2010	G6DE	D	87	1.8	03.1998 → 02.2002	RKA	B	58			
2.0 TDCi	02.2007 → 09.2010	G6DF	D	87	1.8 D	06.1999 → 02.2002	RTK	D	70			
2.0 TDCi	02.2007 → 09.2010	G6DG	D	87	<b>ECOSPORT</b>							
<b>C-MAX II (DXA/CB7, DXA/CEU)</b>					1.0 EcoBoost	10.2013 →	M1JC	B	8			
1.0 EcoBoost	10.2012 →	M1DA	B	9	1.0 EcoBoost	10.2013 →	M1JJ	B	8			
1.0 EcoBoost	10.2012 →	M1DD	B	9	1.0 EcoBoost	10.2013 →	M1JU	B	8			
1.0 EcoBoost	10.2012 →	M2DA	B	8	1.0 EcoBoost	03.2016 →	YYJD	B	8			
1.0 EcoBoost	10.2012 →	M2DC	B	8	1.0 EcoBoost	04.2018 →	SFJL	B	8			
1.5 EcoBoost	03.2015 →	M8DB	B	43	1.5 EcoBlue TDCi	05.2015 →	XVJD	D	11			
1.5 EcoBoost	03.2015 →	M9DB	B	43	1.5 EcoBlue TDCi	11.2017 →	Z2JA	D	26			
1.5 TDCi	03.2015 →	XWDA	D	12	1.5 TDCi	10.2012 →	UGJE	D	11			
1.5 TDCi	03.2015 →	XWDB	D	12	1.5 TDCi	10.2013 →	UGJE	D	11			
1.5 TDCi	03.2015 →	XWDC	D	12	1.5 TDCi	05.2015 →	UGJM	D	11			
1.5 TDCi	03.2015 →	XWDD	D	12	1.5 TDCi	05.2015 →	XUJH	D	11			
1.5 TDCi	03.2015 →	XWDE	D	11	1.5 TDCi EcoBlue	11.2017 →	ZTJA	D	26			
1.5 TDCi	03.2015 →	XXDA	D	12	1.5 TDCi EcoBlue	11.2017 →	ZTJB	D	26			
1.5 TDCi	03.2015 →	XXDC	D	12	1.5 TDCi EcoBlue	11.2017 →	ZTJC	D	26			
1.5 TDCi EOnetic	03.2015 →	AEDA	D	12	1.5 TDCi EcoBlue 4x4	11.2017 →	ZTJA	D	26			
1.6 EcoBoost	12.2010 →	JQDA	B	43	1.5 TDCi EcoBlue 4x4	11.2017 →	ZTJB	D	26			
					1.5 TDCi EcoBlue 4x4	11.2017 →	ZTJC	D	26			
					1.6 Ti-VCT	08.2012 →	HXJD	B	42			
					<b>ESCAPE III</b>							

			Pos				Pos			
1.6 EcoBoost	06.2012 →	JTDA	B	43	1.6 i	08.1989 → 07.1990	LJB	B	51	
1.6 EcoBoost	06.2012 →	JTDB	B	43	1.8 D	01.1989 → 07.1990	RTA	D	70	
<b>ESCORT CLASSIC (AAL, ABL)</b>										
1.6 16V	10.1998 → 07.2000	L1E	B	28	1.8 D	01.1989 → 07.1990	RTB	D	70	
1.6 16V	10.1998 → 07.2000	L1K	B	29	<b>ESCORT IV (GAF/AWF/ABFT/ALF)</b>					
1.8 TD	10.1998 → 07.2000	RFD	D	69	2.0 D	12.1985 → 12.1987	RF	D	103	
1.8 TD	10.1998 → 07.2000	RFK	D	69	<b>ESCORT IV Convertible (ALF)</b>					
<b>ESCORT CLASSIC Turnier (ANL)</b>										
1.6 16V	02.1999 → 07.2000	L1E	B	28	1.4	01.1986 → 07.1990	FUA	B	35	
1.8 TD	02.1999 → 07.2000	RFD	D	69	1.4	02.1987 → 07.1990	F6B	B	35	
1.8 TD	02.1999 → 07.2000	RFK	D	69	1.4	02.1987 → 07.1990	F6D	B	35	
<b>ESCORT I (AFH, ATH)</b>										
1300	06.1968 → 06.1971	J2	B	61	1.6	01.1986 → 12.1987	LP2	B	50	
1300	06.1970 → 02.1976	J2	B	61	1.6	01.1986 → 12.1987	LPA	B	50	
1300	09.1973 → 02.1976	J1F	B	62	1.6 XR3i	01.1986 → 07.1990	LR2	B	51	
<b>ESCORT I Turnier (ADH)</b>										
1300	12.1968 → 12.1975	J2	B	61	1.6 XR3i	01.1986 → 07.1990	LRB	B	51	
1300	06.1970 → 02.1976	J2	B	61	1.6 i	01.1986 → 07.1990	L4B	B	51	
<b>ESCORT II (ATH)</b>										
1.3	12.1974 → 08.1980	J1F	B	62	1.6 i	08.1989 → 07.1990	LJB	B	51	
1.3	12.1974 → 08.1980	J2	B	61	<b>ESCORT IV Turnier (AWF, AVF)</b>					
1.3	03.1979 → 08.1980	J2	B	61	1.3	01.1986 → 03.1989	JLA	B	17	
1.6 RS	12.1974 → 08.1980	LC	B	61	1.3	11.1986 → 07.1988	JPA	B	50	
2.0 RS	08.1975 → 08.1980	NE	B	130	1.4	10.1985 → 10.1990	FUAA	B	34	
2.0 RS (BATN)	03.1973 → 02.1977	NE	B	130	1.4	01.1986 → 07.1990	F6B	B	35	
<b>ESCORT II Turnier</b>										
1.3	04.1975 → 08.1980	J2	B	61	1.4	01.1986 → 07.1990	F6D	B	35	
<b>ESCORT III (GAA)</b>										
1.1	09.1980 → 08.1983	GLB	B	18	1.4	01.1986 → 07.1990	FUA	B	35	
1.1	09.1980 → 08.1983	GMA	B	19	1.4	01.1986 → 07.1990	FUC	B	35	
1.1	09.1980 → 08.1983	GPA	B	19	1.6	01.1986 → 07.1990	LP2	B	50	
1.3	09.1980 → 12.1985	JPA	B	50	1.6 D	01.1986 → 07.1990	LTC	D	56	
1.6	09.1980 → 10.1982	LUA	B	50	1.6 i	01.1986 → 07.1990	L4B	B	51	
1.6	09.1980 → 12.1985	LP1	B	50	1.8 D	01.1989 → 07.1990	RTA	D	70	
1.6	09.1980 → 12.1985	LPA	B	50	1.8 D	01.1989 → 07.1990	RTB	D	70	
1.6 D	02.1984 → 12.1985	LTA	D	56	<b>ESCORT V (AAL, ABL)</b>					
1.6 RS Turbo	11.1984 → 12.1985	LNA	B	48	1.4	07.1990 → 01.1995	F6F	B	35	
1.6 XR3i	10.1982 → 12.1985	LR1	B	51	1.4	07.1990 → 01.1995	F6G	B	33	
1.6 XR3i	10.1982 → 12.1985	LRA	B	51	1.4	09.1990 → 12.1994	F4B	B	35	
1.6 i (GAA)	07.1985 → 12.1985	L4B	B	51	1.4	09.1990 → 12.1994	FUH	B	35	
RS 1600i	05.1982 → 12.1985	LUAE	B	50	1.6	07.1990 → 08.1992	LUJ	B	54	
<b>ESCORT III Convertible (ALD)</b>										
1.3	09.1983 → 12.1985	JPA	B	50	1.6	07.1990 → 08.1992	LUK	B	50	
1.6	09.1983 → 12.1985	LP1	B	50	1.6	07.1990 → 08.1992	LJF	B	48	
1.6	09.1983 → 12.1985	LPA	B	50	1.6 i 16V	09.1992 → 01.1995	L1E	B	28	
1.6 i	09.1983 → 12.1985	LR1	B	51	1.6 i 16V	01.1994 → 01.1995	L1H	B	30	
1.6 i	09.1983 → 12.1985	LRA	B	51	1.8 16V XR3i	02.1992 → 01.1995	RDA	B	57	
<b>ESCORT III Turnier (AWA)</b>										
1.1	09.1980 → 08.1983	GLB	B	18	1.8 16V XR3i	02.1992 → 01.1995	RQB	B	57	
1.1	09.1980 → 08.1983	GMA	B	19	1.8 D	07.1990 → 01.1995	RTE	D	70	
1.3	03.1981 → 12.1985	JPA	B	50	1.8 D	07.1990 → 01.1995	RTF	D	70	
1.6	09.1980 → 12.1985	LP1	B	50	1.8 D	07.1990 → 01.1995	RTH	D	70	
1.6	09.1980 → 12.1985	LPA	B	50	1.8 TD	02.1993 → 01.1995	RFD	D	69	
1.6 D	02.1984 → 12.1985	LTA	D	56	1.8 TD	02.1993 → 01.1995	RFK	D	69	
<b>ESCORT IV (GAF, AWF, ABFT)</b>										
1.3	01.1986 → 03.1989	JLA	B	17	1.8 TD	02.1993 → 01.1995	RFS	D	71	
1.3	11.1986 → 07.1988	JPA	B	50	1.8 XR3i 16V 4x4	08.1993 → 01.1995	RDA	B	57	
1.4	10.1985 → 10.1990	FUAA	B	34	1.8 XR3i 16V 4x4	08.1993 → 01.1995	RQB	B	57	
1.4	01.1986 → 07.1990	F6B	B	35	RS 2000	05.1991 → 01.1995	N7A	B	102	
1.4	01.1986 → 07.1990	F6D	B	35	RS 2000 4x4	05.1991 → 01.1995	N7A	B	102	
1.4	01.1986 → 07.1990	FUA	B	35	<b>ESCORT V Convertible (ALL)</b>					
1.4	01.1986 → 07.1990	FUC	B	35	1.4	07.1990 → 04.1994	F6F	B	35	
1.6	01.1986 → 12.1988	LP2	B	50	1.4	07.1990 → 04.1994	F6G	B	33	
1.6	04.1989 → 07.1990	LUG	B	50	1.4 i	07.1993 → 01.1995	F4B	B	35	
1.6 D	01.1986 → 01.1989	LTC	D	56	1.6	07.1990 → 08.1993	LJF	B	48	
1.6 Turbo RS	01.1986 → 07.1990	LNB	B	48	1.6 16V XR3i	12.1992 → 01.1995	L1E	B	28	
1.6 XR3i	01.1986 → 08.1989	LR2	B	51	1.6 i 16V	02.1994 → 01.1995	L1H	B	30	
1.6 XR3i	01.1986 → 08.1989	LRB	B	51	1.8 16V XR3i	02.1992 → 01.1995	RDA	B	57	
1.6 i	01.1986 → 05.1990	L4B	B	51	1.8 16V XR3i	02.1992 → 01.1995	RQB	B	57	
						<b>ESCORT V Saloon (AFL)</b>				
						1.4	08.1993 → 04.1994	F6F	B	35
						1.4	08.1993 → 04.1994	F6G	B	33
						1.4	08.1993 → 01.1995	F4B	B	35
						1.4	08.1993 → 01.1995	FUH	B	35
						1.6 i 16V	08.1993 → 01.1995	L1E	B	28
						1.6 i 16V	08.1993 → 01.1995	L1K	B	29
						1.6 i 16V	01.1994 → 01.1995	L1H	B	30
						1.8 D	08.1993 → 01.1995	RTE	D	70

					Pos						Pos		
1.8 D	08.1993 → 01.1995	RTF	D	70	<b>ESCORT VI Turnier (GAL, ANL)</b>								
1.8 D	08.1993 → 01.1995	RTH	D	70	1.4	01.1995 → 12.1996	F4B	B	35				
1.8 TD	08.1993 → 01.1995	RFD	D	69	1.4	01.1995 → 02.1999	F4B	B	35				
1.8 TD	08.1993 → 01.1995	RFK	D	69	1.4	01.1995 → 02.1999	FUH	B	35				
1.8 i 16V	08.1993 → 01.1995	RDA	B	57	1.6 16V	01.1995 → 02.1999	L1E	B	28				
<b>ESCORT V Turnier (ANL)</b>					1.6 16V	01.1995 → 02.1999	L1K	B	29				
1.4	07.1990 → 01.1995	F6F	B	35	1.6 i 16V	01.1995 → 08.1995	L1H	B	30				
1.4	07.1990 → 01.1995	F6G	B	33	1.8 16V	01.1995 → 08.1995	RDA	B	57				
1.4	01.1994 → 01.1995	F4B	B	35	1.8 16V	01.1995 → 02.1999	RKC	B	57				
1.4	01.1994 → 01.1995	FUH	B	35	1.8 D	01.1995 → 02.1999	RTE	D	70				
1.6	07.1990 → 08.1992	LUJ	B	54	1.8 D	01.1995 → 02.1999	RTF	D	70				
1.6	07.1990 → 08.1992	LUK	B	50	1.8 D	01.1995 → 02.1999	RTH	D	70				
1.6	07.1990 → 09.1992	LJF	B	48	1.8 TD	01.1995 → 02.1999	RFD	D	69				
1.6 i 16V	09.1992 → 01.1995	L1E	B	28	1.8 TD	01.1995 → 02.1999	RFK	D	69				
1.6 i 16V	01.1994 → 01.1995	L1H	B	30	1.8 Turbo D	12.1995 → 02.1999	RVA	D	72				
1.8 16V	02.1992 → 01.1995	RDA	B	57	<b>FIESTA I (GFBT)</b>								
1.8 D	07.1990 → 01.1995	RTE	D	70	1.1	05.1976 → 08.1983	GLA	B	16				
1.8 D	07.1990 → 01.1995	RTF	D	70	1.1 (WFBT)	02.1981 → 08.1983	GLW	B	18				
1.8 D	07.1990 → 01.1995	RTH	D	70	1.6 XR2	08.1981 → 08.1983	L3E	B	60				
1.8 TD	02.1993 → 01.1995	RFD	D	69	1.6 XR2	09.1981 → 08.1983	L3E	B	60				
1.8 TD	02.1993 → 01.1995	RFK	D	69	<b>FIESTA II (FBD)</b>								
1.8 TD	02.1993 → 01.1995	RFS	D	71	1.3	09.1983 → 09.1989	JPC	B	50				
1.8 i 16V	02.1993 → 01.1995	RQB	B	57	1.3 (FBD)	09.1983 → 01.1987	JPC	B	50				
<b>ESCORT VI (GAL, AAL, ABL)</b>					1.4 (FBD)	10.1985 → 11.1989	FUB	B	35				
1.4	01.1995 → 10.1998	F4B	B	35	1.4 (FBD)	10.1986 → 02.1989	F6A	B	36				
1.4	01.1995 → 10.1998	FUH	B	35	1.4 (FBD)	10.1986 → 02.1989	F6C	B	35				
1.4	01.1995 → 12.1999	F4B	B	35	1.4 (FBD)	02.1987 → 02.1989	FUD	B	35				
1.6	01.2001 → 08.2002	L1K	B	29	1.6	01.1985 → 11.1989	LP3	B	50				
1.6 16V	01.1995 → 10.1998	L1E	B	28	1.6 D (FBD)	04.1984 → 02.1989	LTB	D	56				
1.6 16V 4x4	01.1995 → 10.1998	L1E	B	28	1.6 XR2 (FBD)	03.1984 → 02.1989	LUD	B	51				
1.6 i 16V	01.1995 → 08.1995	L1H	B	30	1.6 XR2 (FBD)	04.1984 → 02.1989	LUB	B	50				
1.8 16V	01.1995 → 08.1995	RDA	B	57	<b>FIESTA III (GFJ)</b>								
1.8 16V	01.1995 → 10.1998	RKC	B	57	1.4	03.1989 → 12.1995	F4A	B	35				
1.8 D	01.1995 → 12.1996	RTE	D	70	1.4	03.1989 → 12.1995	F6E	B	35				
1.8 D	01.1995 → 12.1996	RTF	D	70	1.4	03.1989 → 12.1995	FUG	B	35				
1.8 D	01.1995 → 12.1996	RTH	D	70	1.4	03.1989 → 12.1995	FUJ	B	35				
1.8 TD	01.1995 → 10.1998	RFD	D	69	1.4	11.1992 → 12.1996	FUF	B	37				
1.8 TD	01.1995 → 10.1998	RFK	D	69	1.6	01.1989 → 01.1994	LUH	B	27				
1.8 Turbo D	12.1995 → 10.1998	RVA	D	72	1.6	03.1989 → 12.1992	LUH	B	27				
RS 2000	02.1995 → 02.1998	N7A	B	102	1.6 Turbo (FBJT)	03.1990 → 10.1992	LHA	B	51				
RS 2000 4x4	02.1995 → 10.1998	N7A	B	102	1.6 XR2i	03.1989 → 03.1993	LJD	B	51				
<b>ESCORT VI Convertible (ALL)</b>					1.6 XR2i	03.1989 → 01.1994	LJC	B	51				
1.4	02.1995 → 08.1998	F4B	B	35	1.6 i 16V	01.1994 → 12.1995	L1G	B	28				
1.6 16V XR3i	02.1995 → 12.1996	L1H	B	30	1.8 16V	02.1992 → 12.1995	RDB	B	57				
1.6 16V XR3i	02.1995 → 09.1999	L1E	B	28	1.8 D	03.1989 → 12.1995	RTC	D	70				
1.6 16V XR3i	02.1995 → 09.1999	L1K	B	29	1.8 D	03.1989 → 12.1995	RTD	D	70				
1.8 16V XR3i	02.1995 → 08.1998	RDA	B	57	1.8 D	03.1989 → 12.1995	RTG	D	70				
1.8 16V XR3i	02.1995 → 08.2000	RQB	B	57	1.8 TD	03.1993 → 12.1995	RFL	D	69				
1.8 16V XR3i	10.1995 → 08.1998	RKC	B	57	1.8 XR2i 16V	02.1992 → 12.1995	RQC	B	57				
1.8 TD	09.1995 → 08.1998	RFD	D	69	<b>FIESTA IV (JA , JB )</b>								
1.8 TD	09.1995 → 08.1998	RFK	D	69	1.25 i 16V	08.1995 → 01.2002	DHA	B	5				
1.8 Turbo D	10.1996 → 08.1999	RVA	D	72	1.25 i 16V	08.1995 → 01.2002	DHB	B	5				
<b>ESCORT VI Saloon (GAL, AFL)</b>					1.25 i 16V	08.1995 → 01.2002	DHC	B	5				
1.4	01.1995 → 12.1996	F4B	B	35	1.25 i 16V	08.1995 → 01.2002	DHD	B	5				
1.4	01.1995 → 02.1999	F4B	B	35	1.25 i 16V	08.1995 → 01.2002	DHE	B	5				
1.4	01.1995 → 02.1999	FUH	B	35	1.25 i 16V	08.1995 → 01.2002	DHF	B	5				
1.6	01.2001 → 08.2002	L1K	B	29	1.25 i 16V	08.1995 → 01.2002	DHG	B	5				
1.6 i 16V	01.1995 → 08.1995	L1H	B	30	1.4 i 16V	04.1996 → 01.2002	FHA	B	31				
1.6 i 16V	01.1995 → 02.1999	L1E	B	28	1.4 i 16V	04.1996 → 01.2002	FHE	B	31				
1.6 i 16V	01.1995 → 02.1999	L1K	B	29	1.6	02.1999 → 09.2002	L1V	B	41				
1.8 16V	01.1995 → 08.1995	RDA	B	57	1.6	06.2000 → 06.2002	L1V	B	41				
1.8 16V	01.1995 → 02.1999	RKC	B	57	1.6 16V Sport	02.2000 → 01.2002	L1T	B	41				
1.8 D	01.1995 → 12.1996	RTE	D	70	1.6 16V Sport	02.2000 → 01.2002	L1V	B	41				
1.8 D	01.1995 → 12.1996	RTF	D	70	1.8 D	08.1995 → 04.2000	RTJ	D	70				
1.8 D	01.1995 → 12.1996	RTH	D	70	1.8 D	08.1995 → 04.2000	RTK	D	70				
1.8 TD	01.1995 → 02.1999	RFD	D	69	1.8 DI	04.2000 → 01.2002	RTN	D	73				
1.8 TD	01.1995 → 02.1999	RFK	D	69	1.8 DI	04.2000 → 01.2002	RTP	D	73				
1.8 TD	01.1995 → 02.1999	RFN	D	69	1.8 DI	04.2000 → 01.2002	RTQ	D	73				
1.8 Turbo D	12.1995 → 02.1999	RVA	D	72	<b>FIESTA Saloon</b>								

F

				Pos					Pos
1.0 EcoBoost	09.2013 →	M1JE	B	8	<b>FIESTA VII (HJ, HF)</b>				
1.0 EcoBoost	09.2013 →	M1JH	B	8	1.0 EcoBoost	05.2017 →	M1JL	B	8
1.4 TDCi	05.2002 → 11.2011	F6JC	D	13	1.0 EcoBoost	05.2017 →	M1JM	B	8
1.4 TDCi	05.2002 → 11.2011	KVJA	D	11	1.0 EcoBoost	05.2017 →	SFJE	B	8
1.5 TDCi	01.2011 → 12.2016	15DSOX	D	14	1.0 EcoBoost	05.2017 →	SFJF	B	8
1.6	10.2010 →	HXJA	B	42	1.0 EcoBoost	05.2017 →	SFJH	B	8
1.6	10.2010 →	HXJB	B	42	1.0 EcoBoost	05.2017 →	SFJJ	B	8
1.6 TDCi	10.2010 →	HHJC	D	22	1.0 EcoBoost	05.2017 →	SFJK	B	8
1.6 Ti	04.2010 →	HXJA	B	42	1.0 EcoBoost	05.2017 →	SFJN	B	8
1.6 Ti	04.2010 →	HXJB	B	42	1.0 EcoBoost	05.2017 →	SFJP	B	8
1.6 Ti	03.2015 →	IQJA	B	43	1.0 EcoBoost	06.2017 →	YYJE	B	8
<b>FIESTA V (JH, JD)</b>					1.0 EcoBoost	12.2019 →	MOJA	B	10
1.25 16V	05.2002 → 06.2008	FUJA	B	6	1.0 EcoBoost mHEV	11.2019 →	B7JC	B	10
1.25 16V	05.2002 → 06.2008	FUJB	B	7	1.0 EcoBoost mHEV	07.2020 →	BZJA	B	10
1.25 16V	03.2003 → 06.2008	M7JA	B	7	1.0 EcoBoost mHEV	01.2021 →	B7JA	B	10
1.25 16V	03.2003 → 06.2008	M7JB	B	7	ACTIVE				
1.4 16V	11.2001 → 06.2008	FXJA	B	32	1.0 EcoBoost mHEV	01.2021 →	B7JA	B	10
1.4 16V	11.2001 → 06.2008	FXJB	B	32	ACTIVE				
1.4 TDCi	11.2001 → 06.2008	F6JA	D	13	1.0 EcoBoost mHEV	01.2021 →	B7JB	B	10
1.4 TDCi	11.2001 → 06.2008	F6JB	D	13	ACTIVE				
1.6 16V	11.2001 → 06.2008	FYJA	B	40	1.0 EcoBoost mHEV	01.2021 →	B7JB	B	10
1.6 16V	11.2001 → 06.2008	FYJB	B	40	ACTIVE				
1.6 TDCi	11.2004 → 06.2008	HHJA	D	22	1.0 EcoBoost mHEV	01.2021 →	B7JC	B	10
1.6 TDCi	11.2004 → 06.2008	HHJB	D	22	ACTIVE				
ST150	03.2005 → 06.2008	N4JB	B	115	1.0 EcoBoost mHEV	01.2021 →	BZJA	B	10
<b>FIESTA VI (CB1, CCN)</b>					ACTIVE				
1.0	10.2012 →	P4JA	B	8	1.5 TDCi	05.2017 →	XUJC	D	11
1.0	10.2012 →	P4JB	B	8	1.5 TDCi	05.2017 →	XUJD	D	11
1.0	10.2012 →	P4JC	B	8	1.5 TDCi	05.2017 →	XUJE	D	11
1.0	10.2012 →	P4JD	B	8	1.5 TDCi	05.2017 →	XUJF	D	11
1.0	01.2013 →	XMJA	B	8	1.5 TDCi	05.2017 →	XUJG	D	11
1.0	01.2013 →	XMJB	B	8	1.5 TDCi	05.2017 →	XUJK	D	11
1.0 EcoBoost	09.2012 →	M1JE	B	8	1.5 TDCi	05.2017 →	XUJL	D	11
1.0 EcoBoost	09.2012 →	M1JH	B	8	1.5 TDCi	05.2017 →	XUJM	D	11
1.0 EcoBoost	01.2013 →	SFJA	B	9	1.5 TDCi	05.2017 →	XUJN	D	11
1.0 EcoBoost	01.2013 →	SFJB	B	9	1.5 TDCi	05.2017 →	XWJA	D	11
1.0 EcoBoost	01.2013 →	SFJC	B	9	1.5 TDCi	05.2017 →	XWJB	D	11
1.0 EcoBoost	01.2013 →	SFJD	B	9	1.5 TDCi	05.2017 →	XWJC	D	11
1.0 Sport	05.2014 →	YYJA	B	8	<b>FOCUS C-MAX (DM2)</b>				
1.0 Sport	05.2014 →	YYJB	B	8	1.6	10.2003 → 03.2007	HWDA	B	42
1.25	06.2008 →	SNJA	B	7	1.6	10.2003 → 03.2007	HWDB	B	42
1.25	06.2008 →	SNJB	B	7	1.6	10.2003 → 03.2007	SHDA	B	42
1.4	10.2008 →	SPJA	B	32	1.6	10.2003 → 03.2007	SHDB	B	42
1.4	10.2008 →	SPJC	B	32	1.6	10.2003 → 03.2007	SHDC	B	42
1.4 LPG	01.2009 →	SPJA	B	32	1.6 TDCi	10.2003 → 03.2007	G8DA	D	22
1.4 LPG	01.2009 →	SPJC	B	32	1.6 TDCi	10.2003 → 03.2007	G8DB	D	22
1.4 TDCi	01.2009 →	F6JB	D	13	1.6 TDCi	10.2003 → 03.2007	G8DD	D	20
1.4 TDCi	01.2009 →	F6JD	D	15	1.6 TDCi	10.2003 → 03.2007	G8DE	D	21
1.4 TDCi	07.2010 →	F6JD	D	15	1.6 TDCi	10.2003 → 03.2007	G8DF	D	21
1.4 TDCi	07.2010 →	KVJA	D	14	1.6 TDCi	02.2005 → 03.2007	HHDA	D	22
1.5 TDCi	09.2012 →	UGJC	D	12	1.6 TDCi	02.2005 → 03.2007	HHDB	D	22
1.5 TDCi	09.2012 →	XUJA	D	11	1.6 Ti	08.2004 → 03.2007	HXDA	B	42
1.5 TDCi	09.2012 →	XUJB	D	11	1.8	10.2003 → 03.2007	CSDA	B	75
1.5 TDCi	05.2015 →	XVJB	D	11	1.8	10.2003 → 03.2007	CSDB	B	75
1.5 TDCi	05.2015 →	XVJC	D	11	1.8	04.2004 → 03.2007	QQDA	B	75
1.6	10.2010 →	HXJA	B	42	1.8	04.2004 → 03.2007	QQDB	B	75
1.6 ST	03.2013 →	JTJA	B	43	1.8	09.2005 → 03.2007	QQDC	B	75
1.6 ST	03.2013 →	JTJB	B	43	1.8 TDCi	01.2005 → 03.2007	KKDA	D	73
1.6 TDCi	06.2008 →	HHJC	D	22	1.8 TDCi	01.2005 → 03.2007	KKDB	D	73
1.6 TDCi	06.2008 →	HHJD	D	22	2.0	03.2004 → 03.2007	AODA	B	115
1.6 TDCi	06.2008 →	HHJE	D	22	2.0	03.2004 → 03.2007	AODB	B	115
1.6 TDCi	06.2008 →	HHJF	D	22	2.0	03.2004 → 03.2007	AODE	B	115
1.6 TDCi	06.2008 →	UBJA	D	22	2.0	03.2004 → 03.2007	SYDA	B	115
1.6 TDCi	02.2010 →	T3JA	D	24	2.0 TDCi	10.2003 → 03.2007	G6DA	D	87
1.6 TDCi	02.2010 →	TZJA	D	23	2.0 TDCi	10.2003 → 03.2007	G6DB	D	87
1.6 TDCi	02.2010 →	TZJB	D	23	2.0 TDCi	10.2003 → 03.2007	G6DC	D	87
1.6 Ti	06.2008 →	HXJA	B	42	2.0 TDCi	10.2003 → 03.2007	G6DD	D	87
1.6 Ti	06.2008 →	HXJB	B	42	2.0 TDCi	10.2003 → 03.2007	G6DE	D	87
1.6 Ti	09.2012 →	IQJA	B	43	2.0 TDCi	10.2003 → 03.2007	G6DF	D	87
					2.0 TDCi	10.2003 → 03.2007	G6DG	D	87



						Pos							Pos
<b>FOCUS I (DAW, DBW)</b>							1.6	07.2004 → 09.2012	SHDB	B	42		
1.6	07.2003 → 06.2007	FYDA	B	40			1.6	07.2004 → 09.2012	SHDC	B	42		
1.6 16V	10.1998 → 11.2004	FYDA	B	40			1.6 TDCi	07.2004 → 09.2012	G8DA	D	22		
1.6 16V	10.1998 → 11.2004	FYDB	B	40			1.6 TDCi	07.2004 → 09.2012	G8DB	D	22		
1.6 16V	10.1998 → 11.2004	FYDC	B	40			1.6 TDCi	07.2004 → 09.2012	G8DC	D	22		
1.6 16V	10.1998 → 11.2004	FYDD	B	40			1.6 TDCi	07.2004 → 09.2012	G8DD	D	20		
1.6 16V	10.1998 → 11.2004	FYDH	B	40			1.6 TDCi	07.2004 → 09.2012	G8DE	D	21		
1.6 16V Flexifuel	01.2002 → 11.2004	FYDH	B	40			1.6 TDCi	07.2004 → 09.2012	G8DF	D	21		
1.8 16V	10.1998 → 11.2004	EYDB	B	59			1.6 TDCi	07.2004 → 09.2012	MTDA	D	22		
1.8 16V	10.1998 → 11.2004	EYDC	B	59			1.6 TDCi	01.2005 → 09.2012	GPDA	D	22		
1.8 DI / TDDi	08.1999 → 11.2004	BHDA	D	73			1.6 TDCi	01.2005 → 09.2012	GPDC	D	22		
1.8 DI / TDDi	08.1999 → 11.2004	BHDB	D	73			1.6 TDCi	01.2005 → 09.2012	HHDA	D	22		
1.8 TDCi	03.2001 → 11.2004	F9DA	D	73			1.6 TDCi	01.2005 → 09.2012	HHDB	D	22		
1.8 TDCi	03.2001 → 11.2004	F9DB	D	73			1.6 Ti	07.2004 → 09.2012	HXDA	B	42		
1.8 TDCi	08.2002 → 11.2004	FFDA	D	73			1.6 Ti	07.2004 → 09.2012	HXDB	B	42		
1.8 Turbo DI / TDDi	10.1998 → 11.2004	C9DA	D	73			1.8	03.2006 → 09.2012	QQDA	B	75		
1.8 Turbo DI / TDDi	10.1998 → 11.2004	C9DB	D	73			1.8	03.2006 → 09.2012	QQDB	B	75		
1.8 Turbo DI / TDDi	10.1998 → 11.2004	C9DC	D	73			1.8 Flexifuel	01.2006 → 09.2012	QQDA	B	75		
2.0	06.2005 → 09.2008	AODA	B	115			1.8 Flexifuel	01.2006 → 09.2012	QQDB	B	75		
2.0	06.2005 → 09.2008	AODE	B	115			1.8 TDCi	01.2005 → 09.2012	KKDA	D	73		
2.0 16V	10.1998 → 11.2004	EDDB	B	82			2.0	07.2004 → 09.2012	AODA	B	115		
2.0 16V	10.1998 → 11.2004	EDDC	B	83			2.0	07.2004 → 09.2012	AODB	B	115		
<b>FOCUS I Saloon (DFW)</b>							2.0	07.2004 → 09.2012	AODE	B	115		
1.6 16V	02.1999 → 11.2004	FYDA	B	40			2.0	06.2005 → 09.2008	SYDA	B	115		
1.6 16V	02.1999 → 11.2004	FYDB	B	40			2.0 CNG	04.2009 → 07.2011	SYDA	B	115		
1.6 16V	02.1999 → 11.2004	FYDC	B	40			2.0 Flex	10.2008 → 03.2010	SYDA	B	115		
1.6 16V	02.1999 → 11.2004	FYDD	B	40			2.0 LPG	06.2008 → 07.2011	SYDA	B	115		
1.6 16V	02.1999 → 11.2004	FYDH	B	40			2.0 TDCi	07.2004 → 01.2008	G6DE	D	87		
1.8 16V	02.1999 → 11.2004	EYDB	B	59			2.0 TDCi	07.2004 → 01.2008	G6DF	D	87		
1.8 16V	02.1999 → 11.2004	EYDC	B	59			2.0 TDCi	07.2004 → 09.2012	G6DA	D	87		
1.8 TDCi	03.2001 → 11.2004	F9DA	D	73			2.0 TDCi	07.2004 → 09.2012	G6DB	D	87		
1.8 TDCi	03.2001 → 11.2004	F9DB	D	73			2.0 TDCi	07.2004 → 09.2012	G6DD	D	87		
1.8 TDCi	08.2002 → 11.2004	FFDA	D	73			2.0 TDCi	07.2004 → 09.2012	G6DG	D	87		
1.8 Turbo DI / TDDi	02.1999 → 11.2004	C9DA	D	73			2.5 ST	10.2005 → 09.2012	HYDA	B	76		
1.8 Turbo DI / TDDi	02.1999 → 11.2004	C9DB	D	73			<b>FOCUS II Convertible</b>						
1.8 Turbo DI / TDDi	02.1999 → 11.2004	C9DC	D	73			1.6	10.2006 → 09.2010	HWDA	B	42		
1.8 Turbo DI / TDDi	08.2001 → 03.2005	BHDA	D	73			1.6	10.2006 → 09.2010	HWDB	B	42		
1.8 Turbo DI / TDDi	08.2001 → 03.2005	BHDB	D	73			1.6	10.2006 → 09.2010	SHDA	B	42		
2.0	06.2005 → 11.2009	AODA	B	115			1.6	10.2006 → 09.2010	SHDB	B	42		
2.0	06.2005 → 11.2009	AODE	B	115			1.6	10.2006 → 09.2010	SHDC	B	42		
2.0 16V	02.1999 → 11.2004	EDDB	B	82			2.0	10.2006 → 09.2010	AODA	B	115		
2.0 16V	02.1999 → 11.2004	EDDC	B	83			2.0	10.2006 → 09.2010	AODB	B	115		
<b>FOCUS I Turnier (DNW)</b>							2.0	10.2006 → 09.2010	AODE	B	115		
1.6 16V	02.1999 → 11.2004	FYDA	B	40			2.0	10.2006 → 09.2010	SYDA	B	115		
1.6 16V	02.1999 → 11.2004	FYDB	B	40			2.0 TDCi	10.2006 → 09.2010	G6DA	D	87		
1.6 16V	02.1999 → 11.2004	FYDC	B	40			2.0 TDCi	10.2006 → 09.2010	G6DB	D	87		
1.6 16V	02.1999 → 11.2004	FYDD	B	40			2.0 TDCi	10.2006 → 09.2010	G6DD	D	87		
1.6 16V	02.1999 → 11.2004	FYDH	B	40			2.0 TDCi	10.2006 → 09.2010	G6DG	D	87		
1.6 16V Flexifuel	01.2002 → 11.2004	FYDH	B	40			<b>FOCUS II Saloon (DB_, FCH, DH)</b>						
1.8 16V	02.1999 → 11.2004	EYDB	B	59			1.4	04.2005 → 09.2012	ASDA	B	32		
1.8 16V	02.1999 → 11.2004	EYDC	B	59			1.4	04.2005 → 09.2012	ASDB	B	32		
1.8 DI / TDDi	08.1999 → 11.2004	BHDA	D	73			1.6	04.2005 → 09.2012	HWDA	B	42		
1.8 DI / TDDi	08.1999 → 11.2004	BHDB	D	73			1.6	04.2005 → 09.2012	HWDB	B	42		
1.8 TDCi	03.2001 → 11.2004	F9DA	D	73			1.6	04.2005 → 09.2012	SHDA	B	42		
1.8 TDCi	03.2001 → 11.2004	F9DB	D	73			1.6	04.2005 → 09.2012	SHDB	B	42		
1.8 TDCi	08.2002 → 11.2004	FFDA	D	73			1.6	04.2005 → 09.2012	SHDC	B	42		
1.8 Turbo DI / TDDi	02.1999 → 11.2004	C9DA	D	73			1.6 TDCi	04.2005 → 09.2012	G8DA	D	22		
1.8 Turbo DI / TDDi	02.1999 → 11.2004	C9DB	D	73			1.6 TDCi	04.2005 → 09.2012	G8DB	D	22		
1.8 Turbo DI / TDDi	02.1999 → 11.2004	C9DC	D	73			1.6 TDCi	04.2005 → 09.2012	G8DC	D	22		
2.0 16V	02.1999 → 11.2004	EDDB	B	82			1.6 TDCi	04.2005 → 09.2012	G8DD	D	20		
2.0 16V	02.1999 → 11.2004	EDDC	B	83			1.6 TDCi	04.2005 → 09.2012	G8DE	D	21		
<b>FOCUS II (DA_)</b>							1.6 TDCi	04.2005 → 09.2012	G8DF	D	21		
2.3i 16V (USA)	11.2004 → 11.2010	GZ	B	115			1.6 TDCi	04.2005 → 09.2012	GPDA	D	22		
<b>FOCUS II (DA_, HCP, DP)</b>							1.6 TDCi	04.2005 → 09.2012	GPDC	D	22		
1.4	07.2004 → 09.2012	ASDA	B	32			1.6 TDCi	04.2005 → 09.2012	HHDA	D	22		
1.4	07.2004 → 09.2012	ASDB	B	32			1.6 TDCi	04.2005 → 09.2012	HHDB	D	22		
1.6	07.2004 → 09.2012	HWDA	B	42			1.6 TDCi	04.2005 → 09.2012	MTDA	D	22		
1.6	07.2004 → 09.2012	HWDB	B	42			1.6 Ti	04.2005 → 09.2012	HXDA	B	42		
1.6	07.2004 → 09.2012	SHDA	B	42			1.6 Ti	04.2005 → 09.2012	HXDB	B	42		

F



				Pos					Pos
1.8	03.2006 → 09.2012	QQDA	B	75	1.5 TDCi	09.2014 →	XWDA	D	12
1.8	03.2006 → 09.2012	QQDB	B	75	1.5 TDCi	09.2014 →	XWDB	D	12
1.8 Flexifuel	06.2006 → 07.2011	QQDA	B	75	1.5 TDCi	09.2014 →	XWDC	D	12
1.8 Flexifuel	06.2006 → 07.2011	QQDB	B	75	1.5 TDCi	09.2014 →	XWDD	D	12
1.8 TDCi	04.2005 → 09.2012	KKDA	D	73	1.5 TDCi	09.2014 →	XWDE	D	11
2.0	04.2005 → 07.2011	AODA	B	115	1.5 TDCi	09.2014 →	XXDA	D	12
2.0	04.2005 → 07.2011	AODB	B	115	1.5 TDCi	09.2014 →	XXDC	D	12
2.0	04.2005 → 07.2011	AODE	B	115	1.5 TDCi ECOnetic	09.2014 →	AEDA	D	12
2.0	04.2005 → 07.2011	SYDA	B	115	1.5 TDCi ECOnetic	09.2014 →	XXDB	D	12
2.0	06.2005 → 09.2012	SYDA	B	115	1.6 EcoBoost	07.2010 →	JQDA	B	43
2.0 Flex	04.2010 → 09.2013	SYDA	B	115	1.6 EcoBoost	07.2010 →	JQDB	B	43
2.0 TDCi	04.2005 → 09.2012	G6DA	D	87	1.6 EcoBoost	07.2010 →	JTDA	B	43
2.0 TDCi	04.2005 → 09.2012	G6DB	D	87	1.6 EcoBoost	07.2010 →	JTDB	B	43
2.0 TDCi	04.2005 → 09.2012	G6DD	D	87	1.6 TDCi	07.2010 →	T1DA	D	23
2.0 TDCi	04.2005 → 09.2012	G6DG	D	87	1.6 TDCi	07.2010 →	T1DB	D	23
<b>FOCUS II Turnier (DA_, FFS, DS)</b>					1.6 TDCi	07.2010 →	T3DA	D	23
1.4	07.2004 → 09.2012	ASDA	B	32	1.6 TDCi	07.2010 →	T3DB	D	23
1.4	07.2004 → 09.2012	ASDB	B	32	1.6 TDCi ECOnetic	05.2012 →	NGDA	D	25
1.6	07.2004 → 07.2011	HWDA	B	42	1.6 Ti	07.2010 →	IQDB	B	43
1.6	07.2004 → 07.2011	HWDB	B	42	2.0 TDCi	07.2010 →	TXDB	D	94
1.6	07.2004 → 07.2011	SHDA	B	42	2.0 TDCi	07.2010 →	TYDA	D	94
1.6	07.2004 → 07.2011	SHDB	B	42	2.0 TDCi	07.2010 →	UFDB	D	94
1.6	07.2004 → 07.2011	SHDC	B	42	2.0 TDCi	07.2010 →	UKDB	D	94
1.6 TDCi	07.2004 → 09.2012	G8DA	D	22	2.0 TDCi	11.2014 →	T7DB	D	96
1.6 TDCi	07.2004 → 09.2012	G8DB	D	22	2.0 TDCi ST	11.2014 →	T8DA	D	96
1.6 TDCi	07.2004 → 09.2012	G8DC	D	22	<b>FOCUS III Saloon</b>				
1.6 TDCi	07.2004 → 09.2012	G8DD	D	20	1.0 EcoBoost	02.2012 →	M1DA	B	9
1.6 TDCi	07.2004 → 09.2012	G8DE	D	21	1.0 EcoBoost	02.2012 →	M1DC	B	9
1.6 TDCi	07.2004 → 09.2012	G8DF	D	21	1.0 EcoBoost	02.2012 →	M1DD	B	9
1.6 TDCi	07.2004 → 09.2012	GPDA	D	22	1.0 EcoBoost	02.2012 →	M2DA	B	8
1.6 TDCi	07.2004 → 09.2012	GPDC	D	22	1.0 EcoBoost	02.2012 →	M2DB	B	8
1.6 TDCi	07.2004 → 09.2012	HHDA	D	22	1.0 EcoBoost	02.2012 →	M2DC	B	8
1.6 TDCi	07.2004 → 09.2012	HHDB	D	22	1.0 EcoBoost	02.2012 →	SFDA	B	8
1.6 TDCi	07.2004 → 09.2012	MTDA	D	22	1.0 EcoBoost	02.2012 →	SFDB	B	8
1.6 TDCi	12.2007 → 09.2012	G8DA	D	22	1.0 EcoBoost	10.2017 →	M1DH	B	8
1.6 Ti	07.2004 → 09.2012	HXDA	B	42	1.5 EcoBoost	11.2014 →	M8DA	B	43
1.6 Ti	07.2004 → 09.2012	HXDB	B	42	1.5 EcoBoost	11.2014 →	M8DB	B	43
1.8	03.2006 → 09.2012	QQDA	B	75	1.5 EcoBoost	11.2014 →	M9DA	B	43
1.8	03.2006 → 09.2012	QQDB	B	75	1.5 EcoBoost	11.2014 →	M9DB	B	43
1.8 Flexifuel	01.2006 → 09.2012	QQDA	B	75	1.5 EcoBoost	05.2015 →	M9DA	B	43
1.8 Flexifuel	01.2006 → 09.2012	QQDB	B	75	1.5 EcoBoost	05.2015 →	M9DB	B	43
1.8 TDCi	07.2004 → 09.2012	KKDA	D	73	1.5 TDCi	11.2014 →	XWDA	D	12
2.0	07.2004 → 09.2012	AODA	B	115	1.5 TDCi	11.2014 →	XWDB	D	12
2.0	07.2004 → 09.2012	AODB	B	115	1.5 TDCi	11.2014 →	XWDC	D	12
2.0	07.2004 → 09.2012	AODE	B	115	1.5 TDCi	11.2014 →	XWDD	D	12
2.0	07.2004 → 09.2012	SYDA	B	115	1.5 TDCi	11.2014 →	XWDE	D	11
2.0 LPG	06.2008 → 07.2011	SYDA	B	115	1.5 TDCi	11.2014 →	XXDA	D	12
2.0 TDCi	07.2004 → 01.2008	G6DE	D	87	1.5 TDCi	11.2014 →	XXDC	D	12
2.0 TDCi	07.2004 → 01.2008	G6DF	D	87	1.5 TDCi ECOnetic	11.2014 →	AEDA	D	12
2.0 TDCi	07.2004 → 09.2012	G6DA	D	87	1.5 TDCi ECOnetic	11.2014 →	XXDB	D	12
2.0 TDCi	07.2004 → 09.2012	G6DB	D	87	1.6 EcoBoost	07.2010 →	JQDA	B	43
2.0 TDCi	07.2004 → 09.2012	G6DD	D	87	1.6 EcoBoost	07.2010 →	JQDB	B	43
2.0 TDCi	07.2004 → 09.2012	G6DG	D	87	1.6 EcoBoost	07.2010 →	JTDA	B	43
<b>FOCUS III</b>					1.6 EcoBoost	07.2010 →	JTDB	B	43
1.0 EcoBoost	02.2012 →	M1DA	B	9	1.6 TDCi	07.2010 →	T1DA	D	23
1.0 EcoBoost	02.2012 →	M1DC	B	9	1.6 TDCi	07.2010 →	T1DB	D	23
1.0 EcoBoost	02.2012 →	M1DD	B	9	1.6 TDCi	07.2010 →	T3DA	D	23
1.0 EcoBoost	02.2012 →	M2DA	B	8	1.6 TDCi	07.2010 →	T3DB	D	23
1.0 EcoBoost	02.2012 →	M2DB	B	8	1.6 TDCi	05.2012 →	NGDA	D	25
1.0 EcoBoost	02.2012 →	M2DC	B	8	1.6 Ti	07.2010 →	IQDB	B	43
1.0 EcoBoost	02.2012 →	SFDA	B	8	2.0 TDCi	07.2010 →	TXDB	D	94
1.0 EcoBoost	02.2012 →	SFDB	B	8	2.0 TDCi	07.2010 →	TYDA	D	94
1.0 EcoBoost	10.2017 →	M1DH	B	8	2.0 TDCi	07.2010 →	UFDB	D	94
1.5 EcoBoost	09.2014 →	M8DA	B	43	2.0 TDCi	07.2010 →	UKDB	D	94
1.5 EcoBoost	09.2014 →	M8DB	B	43	2.0 TDCi	11.2014 →	T7DB	D	96
1.5 EcoBoost	09.2014 →	M9DA	B	43	<b>FOCUS III Turnier</b>				
1.5 EcoBoost	09.2014 →	M9DB	B	43	1.0 EcoBoost	02.2012 →	M1DA	B	9
1.5 EcoBoost	05.2015 →	M9DA	B	43	1.0 EcoBoost	02.2012 →	M1DC	B	9
1.5 EcoBoost	05.2015 →	M9DB	B	43	1.0 EcoBoost	02.2012 →	M1DD	B	9

			Pos				Pos		
1.0 EcoBoost	02.2012 →	M2DA	B	8	1.9 TDI	03.1995 → 05.2006	AHU	D	44
1.0 EcoBoost	02.2012 →	M2DB	B	8	1.9 TDI	08.1997 → 04.2000	AFN	D	44
1.0 EcoBoost	02.2012 →	M2DC	B	8	1.9 TDI	08.1997 → 04.2000	AVG	D	45
1.0 EcoBoost	02.2012 →	SFDA	B	8	1.9 TDI	04.2000 → 05.2006	ANU	D	46
1.0 EcoBoost	02.2012 →	SFDB	B	8	1.9 TDI	04.2000 → 05.2006	AUY	D	46
1.0 EcoBoost	10.2017 →	M1DH	B	8	1.9 TDI	02.2003 → 05.2006	ASZ	D	46
1.5 EcoBoost	09.2014 →	M8DA	B	43	1.9 TDI	05.2005 → 05.2006	BTB	D	47
1.5 EcoBoost	09.2014 →	M8DB	B	43	2.0 i	11.1995 → 05.2006	NSE	B	101
1.5 EcoBoost	09.2014 →	M9DA	B	43	2.0 i	11.1995 → 05.2006	ZVSA	B	101
1.5 EcoBoost	09.2014 →	M9DB	B	43	2.8 V6	04.2000 → 05.2006	AYL	B	65
1.5 TDCi	09.2014 →	XWDA	D	12	2.8 i V6	11.1995 → 04.2000	AAA	B	64
1.5 TDCi	09.2014 →	XWDB	D	12	2.8 i V6	11.1995 → 04.2000	AMY	B	63
1.5 TDCi	09.2014 →	XWDC	D	12	2.8 i V6 4x4	04.1996 → 04.2000	AAA	B	64
1.5 TDCi	09.2014 →	XWDD	D	12	2.8 i V6 4x4	04.1996 → 04.2000	AMY	B	63
1.5 TDCi	09.2014 →	XWDE	D	11	<b>GALAXY II (WA6)</b>				
1.5 TDCi	09.2014 →	XXDA	D	12	1.6 EcoBoost	11.2010 → 06.2015	JTWA	B	43
1.5 TDCi	09.2014 →	XXDC	D	12	1.6 EcoBoost	11.2010 → 06.2015	JTWB	B	43
1.5 TDCi ECOnetic	09.2014 →	AEDA	D	12	1.6 TDCi	02.2011 → 06.2015	T1WA	D	25
1.5 TDCi ECOnetic	09.2014 →	XXDB	D	12	1.6 TDCi	02.2011 → 06.2015	T1WB	D	25
1.5 TDCi ECOnetic	09.2015 →	AEDA	D	12	1.8 TDCi	05.2006 → 06.2015	FFWA	D	73
1.6 EcoBoost	07.2010 →	JQDA	B	43	1.8 TDCi	05.2006 → 06.2015	QYWA	D	73
1.6 EcoBoost	07.2010 →	JQDB	B	43	2.0	05.2006 → 06.2015	AOWA	B	115
1.6 EcoBoost	07.2010 →	JTDA	B	43	2.0	05.2006 → 06.2015	AOWB	B	115
1.6 EcoBoost	07.2010 →	JTDB	B	43	2.0 TDCi	05.2006 → 06.2015	AZWA	D	87
1.6 TDCi	07.2010 →	T1DA	D	23	2.0 TDCi	05.2006 → 06.2015	AZWC	D	87
1.6 TDCi	07.2010 →	T1DB	D	23	2.0 TDCi	05.2006 → 06.2015	QXWA	D	87
1.6 TDCi	07.2010 →	T3DA	D	23	2.0 TDCi	05.2006 → 06.2015	QXWB	D	87
1.6 TDCi	07.2010 →	T3DB	D	23	2.0 TDCi	05.2006 → 06.2015	QXWC	D	88
1.6 TDCi ECOnetic	05.2012 →	NGDA	D	25	2.0 TDCi	11.2007 → 06.2015	KLWA	D	87
1.6 Ti	07.2010 →	IQDB	B	43	2.0 TDCi	03.2010 → 06.2015	TXWA	D	93
2.0 TDCi	07.2010 →	TXDB	D	94	2.2 TDCi	03.2008 → 12.2012	Q4WA	D	91
2.0 TDCi	07.2010 →	TYDA	D	94	2.2 TDCi	11.2010 → 06.2015	KNWA	D	95
2.0 TDCi	07.2010 →	UFDB	D	94	<b>GALAXY III (CK)</b>				
2.0 TDCi	07.2010 →	UKDB	D	94	2.0 EcoBlue	07.2018 →	BCCC	D	80
2.0 TDCi	11.2014 →	T7DB	D	96	2.0 EcoBlue	07.2018 →	YMCB	D	80
2.0 TDCi ST	11.2014 →	T8DA	D	96	2.0 EcoBlue	07.2018 →	YNCA	D	80
<b>FOCUS IV (HN)</b>					2.0 EcoBlue 4x4	07.2018 →	BCCC	D	80
1.0 EcoBoost	01.2018 →	B3DA	B	10	2.0 EcoBlue 4x4	07.2018 →	YMCB	D	80
1.0 EcoBoost	01.2018 →	B7DA	B	10	2.0 TDCi	01.2015 → 06.2018	T7CJ	D	96
1.0 EcoBoost	05.2018 →	SFDC	B	8	2.0 TDCi	01.2015 → 06.2018	T7CK	D	96
1.0 EcoBoost MHEV	01.2021 →	B7DA	B	10	2.0 TDCi	01.2015 → 06.2018	T7CL	D	96
ACTIVE					2.0 TDCi	01.2015 → 06.2018	T8CH	D	96
1.0 EcoBoost mHEV	06.2020 →	B7DA	B	10	2.0 TDCi	01.2015 → 06.2018	T8CI	D	96
2.0 EcoBlue	01.2018 →	YLDA	D	80	2.0 TDCi	01.2015 → 06.2018	T8CJ	D	96
<b>FOCUS IV Saloon (HM)</b>					2.0 TDCi	01.2015 → 06.2018	UFCA	D	96
1.0 EcoBoost	11.2018 →	B3DA	B	10	2.0 TDCi	01.2015 → 06.2018	UFCE	D	96
1.0 EcoBoost	11.2018 →	B7DA	B	10	2.0 TDCi 4x4	05.2015 → 06.2018	T7CJ	D	96
<b>FOCUS IV Turnier (HP)</b>					2.0 TDCi 4x4	05.2015 → 06.2018	T7CL	D	96
1.0 EcoBoost	09.2018 →	B3DA	B	10	2.0 TDCi 4x4	05.2015 → 06.2018	T8CH	D	96
1.0 EcoBoost	09.2018 →	B7DA	B	10	2.0 TDCi 4x4	05.2015 → 06.2018	T8CI	D	96
1.0 EcoBoost	09.2018 →	SFDC	B	8	2.0 TDCi 4x4	05.2015 → 06.2018	T8CJ	D	96
2.0 EcoBlue	09.2018 →	YLDA	D	80	2.0 TDCi Bi-Turbo	01.2015 → 06.2018	T9CB	D	96
<b>FUSION (USA)</b>					2.0 TDCi Bi-Turbo	01.2015 → 06.2018	T9CC	D	96
1.6 EcoBoost (USA)	09.2012 →	JTDA	B	43	<b>GRANADA</b>				
1.6 EcoBoost (USA)	09.2012 →	JTDB	B	43	2.0 D	08.1977 → 06.1979	VTA	D	120
<b>FUSION (JU )</b>					2.0i	04.1985 → 02.1992	NRA	B	135
1.25	08.2004 → 12.2012	FUJA	B	6	2.0i	05.1989 → 02.1992	N9B	B	101
1.25	08.2004 → 12.2012	FUJB	B	7	2.0i	05.1989 → 02.1992	N9D	B	101
1.4	08.2002 → 12.2012	FXJA	B	32	2.0i	02.1992 → 12.1994	N9F	B	101
1.4	08.2002 → 12.2012	FXJB	B	32	2.3 D	10.1982 → 02.1985	LXD 2	D	143
1.4 TDCi	08.2002 → 12.2012	F6JA	D	13	2.4i	09.1986 → 02.1992	ARC	B	79
1.4 TDCi	08.2002 → 12.2012	F6JB	D	13	2.5 TD	06.1988 → 12.1994	SFA	D	144
1.6	08.2002 → 11.2009	FYJA	B	40	2.5 TD	06.1988 → 12.1994	SFB	D	144
1.6	08.2002 → 11.2009	FYJB	B	40	2.9i	09.1986 → 02.1992	BRC	B	138
1.6	08.2002 → 11.2009	FYJC	B	42	<b>GRANADA II (GU)</b>				
1.6 TDCi	11.2004 → 12.2012	HHJA	D	22	1.7	08.1977 → 07.1981	MY	B	129
1.6 TDCi	11.2004 → 12.2012	HHJB	D	22	2.0	08.1977 → 08.1985	NYP	B	78
<b>GALAXY I (WGR)</b>					2.0	08.1979 → 08.1985	NEP	B	135
1.9 TDI	03.1995 → 05.2006	1Z	D	44	2.0	08.1981 → 08.1985	NEK	B	136

F

				Pos					Pos
2.5 D	08.1982 → 08.1985	STP	D	144	1.6 EcoBoost 4x4	10.2012 → 04.2015	JTMA	B	43
<b>GRANADA Turnier (GNU)</b>					1.6 EcoBoost 4x4	03.2013 →	JQMA	B	43
1.7	08.1977 → 07.1981	MYE	B	129	1.6 EcoBoost 4x4	03.2013 →	JQMB	B	43
2.0	08.1977 → 06.1985	NYP	B	78	1.6 EcoBoost 4x4	03.2013 →	JTMA	B	43
2.0	08.1979 → 08.1985	NEP	B	135	2.0 TDCi	09.2014 →	T7MA	D	96
2.0	08.1981 → 08.1985	NEK	B	136	2.0 TDCi	09.2014 →	T7MB	D	96
2.5 D	08.1982 → 08.1985	STP	D	144	2.0 TDCi 4x4	03.2013 →	TXDA	D	92
<b>GRAND C-MAX (DXA/CB7, DXA/CEU)</b>					2.0 TDCi 4x4	03.2013 →	TXMA	D	93
1.0 EcoBoost	10.2012 →	B3DA	B	10	2.0 TDCi 4x4	09.2014 →	T7MA	D	96
1.0 EcoBoost	10.2012 →	B7DA	B	10	2.0 TDCi 4x4	09.2014 →	T7MB	D	96
1.0 EcoBoost	10.2012 →	M1DA	B	9	2.0 TDCi 4x4	09.2014 →	T8MA	D	96
1.0 EcoBoost	10.2012 →	M1DD	B	9	2.0 TDCi 4x4	09.2014 →	T8MB	D	96
1.0 EcoBoost	10.2012 →	M2DA	B	8	<b>MAVERICK</b>				
1.0 EcoBoost	10.2012 →	M2DC	B	8	2.3 16V	03.2004 →	GZ	B	115
1.5 EcoBoost	03.2015 →	M8DB	B	43	<b>METROSTAR</b>				
1.5 EcoBoost	03.2015 →	M9DB	B	43	2.5	10.2000 → 02.2007	LCBD	B	67
1.5 TDCi	03.2015 →	XWDA	D	12	<b>MONDEO I (GBP)</b>				
1.5 TDCi	03.2015 →	XWDB	D	12	1.6 i 16V	02.1993 → 08.1996	L1F	B	28
1.5 TDCi	03.2015 →	XWDC	D	12	1.6 i 16V	07.1994 → 07.1996	L1J	B	28
1.5 TDCi	03.2015 →	XWDD	D	12	1.8 TD	06.1993 → 08.1996	RFM	D	69
1.5 TDCi	03.2015 →	XWDE	D	11	1.8 TD	06.1993 → 08.1996	RFN	D	69
1.5 TDCi	03.2015 →	XXDA	D	12	1.8 TD	10.1995 → 08.1996	RFM	D	69
1.5 TDCi	03.2015 →	XXDC	D	12	1.8 TD	10.1995 → 08.1996	RFN	D	69
1.6 EcoBoost	12.2010 →	JQDA	B	43	1.8 i 16V	02.1993 → 08.1996	RKA	B	58
1.6 EcoBoost	12.2010 →	JQDB	B	43	1.8 i 16V	07.1994 → 08.1996	RKB	B	58
1.6 EcoBoost	12.2010 →	JTDA	B	43	1.8 i 16V 4x4	02.1993 → 08.1996	RKA	B	58
1.6 EcoBoost	12.2010 →	JTDB	B	43	2.0 i 16V	02.1993 → 08.1996	NGA	B	84
1.6 TDCi	12.2010 →	T1DA	D	23	2.0 i 16V	12.1994 → 08.1996	NGA	B	84
1.6 TDCi	12.2010 →	T1DB	D	23	2.0 i 16V 4x4	04.1993 → 08.1996	NGA	B	84
1.6 TDCi	12.2010 →	T3DA	D	23	2.0 i 16V 4x4	12.1994 → 08.1996	NGA	B	84
1.6 TDCi	12.2010 →	T3DB	D	23	<b>MONDEO I Saloon (GBP)</b>				
1.6 Ti	12.2010 →	IQDB	B	43	1.6 i 16V	02.1993 → 08.1996	L1F	B	28
2.0 TDCi	12.2010 →	TXDB	D	94	1.6 i 16V	07.1994 → 07.1996	L1J	B	28
2.0 TDCi	02.2011 →	TYDA	D	94	1.8 4x4	02.1993 → 08.1996	RKA	B	58
2.0 TDCi	02.2011 →	UFDB	D	94	1.8 TD	06.1993 → 08.1996	RFM	D	69
2.0 TDCi	02.2011 →	UKDB	D	94	1.8 TD	06.1993 → 08.1996	RFN	D	69
2.0 TDCi	03.2015 →	T7DB	D	96	1.8 TD	10.1995 → 08.1996	RFM	D	69
2.0 TDCi	03.2015 →	T8DE	D	96	1.8 TD	10.1995 → 08.1996	RFN	D	69
<b>KA (RU8)</b>					1.8 i 16V	02.1993 → 08.1996	RKA	B	58
1.2	10.2008 → 05.2016	FP4	B	4	1.8 i 16V	01.1994 → 08.1996	RKB	B	58
1.3 TDCi	10.2008 → 05.2016	169A1000	D	1	2.0 i 16V	02.1993 → 08.1996	NGA	B	84
1.3 TDCi	10.2008 → 05.2016	FD4	D	2	2.0 i 16V 4x4	02.1993 → 08.1996	NGA	B	84
<b>KA+ III (UK, FK)</b>					2.0 i 16V 4x4	12.1994 → 08.1996	NGA	B	84
1.5 TDCi	09.2015 →	15DSOX	D	11	<b>MONDEO I Turnier (BNP)</b>				
1.5 TDCi	02.2018 →	15DSOX	D	11	1.6 i 16V	04.1993 → 08.1996	L1F	B	28
1.5 TDCi	02.2018 →	15DSOX	D	11	1.6 i 16V	07.1994 → 07.1996	L1J	B	28
<b>KA+ III Saloon (TK, FK)</b>					1.8 TD	06.1993 → 08.1996	RFM	D	69
1.0 Flexfuel	08.2014 → 12.2018	P4JA	B	8	1.8 TD	06.1993 → 08.1996	RFN	D	69
1.5 TDCi	09.2015 →	15DSOX	D	11	1.8 TD	11.1995 → 08.1996	RFM	D	69
<b>KUGA I</b>					1.8 TD	11.1995 → 08.1996	RFN	D	69
2.0 TDCi	03.2008 → 11.2012	G6DG	D	87	1.8 i 16V	04.1993 → 08.1996	RKA	B	58
2.0 TDCi	03.2008 → 11.2012	UKDA	D	92	1.8 i 16V	07.1994 → 08.1996	RKB	B	58
2.0 TDCi	03.2010 → 11.2012	UFDA	D	92	1.8 i 16V 4x4	04.1993 → 08.1996	RKA	B	58
2.0 TDCi 4x4	03.2008 → 11.2012	G6DG	D	87	2.0 i 16V	01.1993 → 08.1996	NGA	B	84
2.0 TDCi 4x4	03.2008 → 11.2012	UKDA	D	92	2.0 i 16V	04.1993 → 08.1996	NGA	B	84
2.0 TDCi 4x4	03.2010 → 11.2012	TXDA	D	92	2.0 i 16V 4x4	04.1993 → 08.1996	NGA	B	84
2.0 TDCi 4x4	03.2010 → 11.2012	UFDA	D	92	2.0 i 16V 4x4	12.1994 → 08.1996	NGA	B	84
2.5	03.2009 → 11.2012	HYDB	B	76	<b>MONDEO II (BAP)</b>				
2.5	03.2009 → 11.2012	HYDC	B	76	1.6 i	08.1996 → 09.2000	L1J	B	28
2.5 4x4	02.2008 → 11.2012	HYDB	B	76	1.6 i 16V	05.1998 → 09.2000	L1L	B	29
2.5 4x4	02.2008 → 11.2012	HYDC	B	76	1.6 i 16V	05.1998 → 09.2000	L1N	B	29
<b>KUGA II (DM2)</b>					1.6 i 16V	05.1998 → 09.2000	L1Q	B	29
1.5 EcoBoost	09.2014 →	M8MA	B	43	1.8 TD	08.1996 → 09.2000	RFN	D	69
1.5 EcoBoost 4x4	07.2016 →	M8MA	B	43	1.8 i	08.1996 → 09.2000	RKB	B	58
1.5 TDCi	07.2016 →	XWMB	D	11	1.8 i	08.1996 → 09.2000	RKF	B	57
1.5 TDCi	07.2016 →	XWMC	D	11	1.8 i	08.1996 → 09.2000	RKH	B	57
1.6 EcoBoost	01.2013 →	JTMA	B	43	1.8 i	08.1996 → 09.2000	RKJ	B	57
1.6 EcoBoost	03.2013 →	JQMA	B	43	1.8 i	08.1996 → 09.2000	RKK	B	58
1.6 EcoBoost	03.2013 →	JQMB	B	43	2.0 i	08.1996 → 09.2000	NGA	B	84

				Pos					Pos
2.0 i	08.1996 → 09.2000	NGB	B	85	2.0 TDCi	10.2001 → 03.2007	N7BA	D	104
2.0 i	08.1996 → 09.2000	NGC	B	84	2.0 TDCi	10.2001 → 03.2007	N7BB	D	106
2.0 i	08.1996 → 09.2000	NGD	B	84	2.2 TDCi	09.2004 → 03.2007	QJBA	D	104
<b>MONDEO II Saloon (BFP)</b>					2.2 TDCi	09.2004 → 03.2007	QJBB	D	104
1.6 i	08.1996 → 09.2000	L1J	B	28	2.2 TDCi	09.2004 → 03.2007	QJBC	D	104
1.6 i 16V	05.1998 → 09.2000	L1L	B	29	2.2 TDCi	09.2004 → 03.2007	QJBD	D	104
1.6 i 16V	05.1998 → 09.2000	L1N	B	29	2.5 V6	10.2000 → 03.2007	LCBD	B	67
1.6 i 16V	05.1998 → 09.2000	L1Q	B	29	2.5 V6 24V	10.2000 → 03.2007	LCBD	B	67
1.8 TD	08.1996 → 09.2000	RFN	D	69	<b>MONDEO III Turnier (BWY)</b>				
1.8 i	08.1996 → 09.2000	RKB	B	58	1.8 16V	10.2000 → 03.2007	CGBA	B	75
1.8 i	08.1996 → 09.2000	RKF	B	57	1.8 16V	10.2000 → 03.2007	CHBA	B	75
1.8 i	08.1996 → 09.2000	RKH	B	57	1.8 SCi	06.2003 → 03.2007	CFBA	B	75
1.8 i	08.1996 → 09.2000	RKJ	B	57	2.0 16V	10.2000 → 03.2007	CJBA	B	115
1.8 i	08.1996 → 09.2000	RKK	B	58	2.0 16V	10.2000 → 03.2007	CJBB	B	115
2.0 i	08.1996 → 09.2000	NGA	B	84	2.0 16V DI / TDDi / TDCi	10.2000 → 03.2007	D5BA	D	104
2.0 i	08.1996 → 09.2000	NGB	B	85	2.0 16V DI / TDDi / TDCi	10.2000 → 03.2007	SDBA	D	104
2.0 i	08.1996 → 09.2000	NGC	B	84	2.0 16V TDDi / TDCi	10.2000 → 03.2007	D6BA	D	104
2.0 i	08.1996 → 09.2000	NGD	B	84	2.0 16V TDDi / TDCi	10.2000 → 03.2007	HJBA	D	104
2.5 24V	06.2000 → 09.2000	LCBD	B	67	2.0 16V TDDi / TDCi	10.2000 → 03.2007	HJBB	D	104
<b>MONDEO II Turnier (BNP)</b>					2.0 16V TDDi / TDCi	10.2000 → 03.2007	HJBC	D	105
1.6 i	08.1996 → 09.2000	L1J	B	28	2.0 TDCi	10.2001 → 03.2007	FMBA	D	104
1.6 i 16V	05.1998 → 09.2000	L1L	B	29	2.0 TDCi	10.2001 → 03.2007	N7BA	D	104
1.6 i 16V	05.1998 → 09.2000	L1N	B	29	2.0 TDCi	10.2001 → 03.2007	N7BB	D	106
1.6 i 16V	05.1998 → 09.2000	L1Q	B	29	2.2 TDCi	09.2004 → 03.2007	QJBA	D	104
1.8 TD	08.1996 → 09.2000	RFN	D	69	2.2 TDCi	09.2004 → 03.2007	QJBB	D	104
1.8 i	08.1996 → 09.2000	RKA	B	58	2.2 TDCi	09.2004 → 03.2007	QJBC	D	104
1.8 i	08.1996 → 09.2000	RKB	B	58	2.2 TDCi	09.2004 → 03.2007	QJBD	D	104
1.8 i	08.1996 → 09.2000	RKF	B	57	2.5 V6 24V	10.2000 → 03.2007	LCBD	B	67
1.8 i	08.1996 → 09.2000	RKH	B	57	<b>MONDEO IV (BA7)</b>				
1.8 i	08.1996 → 09.2000	RKJ	B	57	1.6 EcoBoost	02.2011 → 01.2015	JTBA	B	43
1.8 i	08.1996 → 09.2000	RKK	B	58	1.6 EcoBoost	02.2011 → 01.2015	JTBB	B	43
2.0 i	08.1996 → 09.2000	NGA	B	84	1.6 TDCi	02.2011 → 01.2015	T1BA	D	23
2.0 i	08.1996 → 09.2000	NGB	B	85	1.6 TDCi	02.2011 → 01.2015	T1BB	D	23
2.0 i	08.1996 → 09.2000	NGC	B	84	1.6 TDCi	02.2011 → 01.2015	T1BC	D	23
2.0 i	08.1996 → 09.2000	NGD	B	84	1.6 Ti	03.2007 → 01.2015	PNBA	B	42
<b>MONDEO III (B5Y)</b>					1.6 Ti	03.2007 → 01.2015	RHBA	B	42
1.8 16V	10.2000 → 03.2007	CGBA	B	75	1.8 TDCi	03.2007 → 01.2015	FFBA	D	73
1.8 16V	10.2000 → 03.2007	CHBA	B	75	1.8 TDCi	06.2007 → 01.2015	KHBA	D	73
1.8 SCi	06.2003 → 03.2007	CFBA	B	75	1.8 TDCi	06.2007 → 01.2015	QYBA	D	73
2.0 16V	10.2000 → 03.2007	CJBA	B	115	2.0	03.2007 → 01.2015	AOBA	B	115
2.0 16V	10.2000 → 03.2007	CJBB	B	115	2.0	03.2007 → 01.2015	AOBC	B	115
2.0 16V DI / TDDi / TDCi	10.2000 → 03.2007	D5BA	D	104	2.0	03.2007 → 01.2015	TBBA	B	115
2.0 16V DI / TDDi / TDCi	10.2000 → 03.2007	SDBA	D	104	2.0	03.2007 → 01.2015	TBBB	B	115
2.0 16V TDDi / TDCi	10.2000 → 03.2007	D6BA	D	104	2.0 Flexifuel	03.2009 → 01.2015	TBBA	B	115
2.0 16V TDDi / TDCi	10.2000 → 03.2007	HJBA	D	104	2.0 Flexifuel	03.2009 → 01.2015	TBBB	B	115
2.0 16V TDDi / TDCi	10.2000 → 03.2007	HJBB	D	104	2.0 LPG	07.2009 → 01.2015	TBBA	B	115
2.0 16V TDDi / TDCi	10.2000 → 03.2007	HJBC	D	105	2.0 TDCi	03.2007 → 12.2014	AZBC	D	87
2.0 TDCi	10.2001 → 03.2007	FMBA	D	104	2.0 TDCi	03.2007 → 01.2015	AZBA	D	87
2.0 TDCi	10.2001 → 03.2007	N7BA	D	104	2.0 TDCi	03.2007 → 01.2015	QXBA	D	87
2.0 TDCi	10.2001 → 03.2007	N7BB	D	106	2.0 TDCi	03.2007 → 01.2015	QXBB	D	87
2.2 TDCi	09.2004 → 03.2007	QJBA	D	104	2.0 TDCi	11.2007 → 01.2015	KLBA	D	87
2.2 TDCi	09.2004 → 03.2007	QJBB	D	104	2.0 TDCi	11.2007 → 01.2015	LPBA	D	87
2.2 TDCi	09.2004 → 03.2007	QJBC	D	104	2.0 TDCi	11.2007 → 01.2015	TYBA	D	89
2.2 TDCi	09.2004 → 03.2007	QJBD	D	104	2.0 TDCi	03.2010 → 01.2015	TXBA	D	93
2.5 V6 24V	10.2000 → 03.2007	LCBD	B	67	2.0 TDCi	03.2010 → 01.2015	TXBB	D	93
<b>MONDEO III Saloon (B4Y)</b>					2.2 TDCi	03.2008 → 10.2010	Q4BA	D	90
1.8 16V	10.2000 → 03.2007	CGBA	B	75	2.2 TDCi	07.2010 → 01.2015	KNBA	D	96
1.8 16V	10.2000 → 03.2007	CHBA	B	75	2.3	07.2007 → 01.2015	SEBA	B	115
1.8 SCi	06.2003 → 03.2007	CFBA	B	75	2.5	03.2007 → 01.2015	HUBA	B	76
2.0	10.2000 → 03.2007	CJBA	B	115	<b>MONDEO IV Saloon (BA7)</b>				
2.0 16V	10.2000 → 03.2007	CJBA	B	115	1.6 EcoBoost	11.2010 → 01.2015	JTBA	B	43
2.0 16V	10.2000 → 03.2007	CJBB	B	115	1.6 EcoBoost	11.2010 → 01.2015	JTBB	B	43
2.0 16V DI / TDDi / TDCi	10.2000 → 03.2007	D5BA	D	104	1.6 TDCi	12.2010 → 01.2015	T1BA	D	23
2.0 16V DI / TDDi / TDCi	10.2000 → 03.2007	SDBA	D	104	1.6 TDCi	12.2010 → 01.2015	T1BB	D	23
2.0 16V TDDi / TDCi	10.2000 → 03.2007	D6BA	D	104	1.6 TDCi	12.2010 → 01.2015	T1BC	D	23
2.0 16V TDDi / TDCi	10.2000 → 03.2007	HJBA	D	104	1.6 Ti	03.2007 → 01.2015	PNBA	B	42
2.0 16V TDDi / TDCi	10.2000 → 03.2007	HJBB	D	104	1.6 Ti	03.2007 → 01.2015	RHBA	B	42
2.0 16V TDDi / TDCi	10.2000 → 03.2007	HJBC	D	105	1.8 TDCi	03.2007 → 01.2015	FFBA	D	73
2.0 TDCi	10.2001 → 03.2007	FMBA	D	104	1.8 TDCi	06.2007 → 01.2015	KHBA	D	73

**F**



			Pos				Pos		
1.8 TDCi	06.2007 → 01.2015	QYBA	D	73	2.0 TDCi 4x4	02.2015 →	T8CD	D	96
2.0	03.2007 → 01.2015	AOBA	B	115	2.0 TDCi 4x4	02.2015 →	T8CL	D	96
2.0	03.2007 → 01.2015	AOBC	B	115	2.0 TDCi Bi-Turbo	03.2015 →	T9CA	D	96
2.0	03.2007 → 01.2015	TBBA	B	115	<b>MONDEO V Saloon (CD)</b>				
2.0	03.2007 → 01.2015	TBBB	B	115	1.0 EcoBoost	02.2015 →	M1CA	B	8
2.0 Flexifuel	03.2009 → 01.2015	TBBA	B	115	1.0 EcoBoost	02.2015 →	M1CB	B	8
2.0 Flexifuel	03.2009 → 01.2015	TBBB	B	115	1.5 EcoBoost	09.2014 →	UNCA	B	43
2.0 LPG	07.2009 → 01.2015	TBBA	B	115	1.5 EcoBoost	09.2014 →	UNCB	B	43
2.0 TDCi	03.2007 → 01.2015	AZBA	D	87	1.5 EcoBoost	09.2014 →	UNCE	B	43
2.0 TDCi	03.2007 → 01.2015	QXBA	D	87	1.5 EcoBoost	09.2014 →	UNCF	B	43
2.0 TDCi	03.2007 → 01.2015	QXBB	D	87	1.5 TDCi	03.2015 →	UGCC	D	11
2.0 TDCi	11.2007 → 01.2015	KLBA	D	87	1.5 TDCi	03.2015 →	XUCA	D	11
2.0 TDCi	11.2007 → 01.2015	LPBA	D	87	2.0 TDCi	09.2014 →	T7CE	D	96
2.0 TDCi	11.2007 → 01.2015	TYBA	D	89	2.0 TDCi	05.2015 →	T8CC	D	96
2.0 TDCi	08.2008 → 12.2014	AZBC	D	87	2.0 TDCi	05.2015 →	T8CD	D	96
2.0 TDCi	03.2010 → 01.2015	TXBA	D	93	2.0 TDCi	05.2015 →	T8CL	D	96
2.0 TDCi	03.2010 → 01.2015	TXBB	D	93	2.0 TDCi 4x4	09.2014 →	T7CE	D	96
2.2 TDCi	03.2008 → 10.2010	Q4BA	D	90	2.0 TDCi 4x4	05.2015 →	T8CC	D	96
2.2 TDCi	10.2010 → 01.2015	KNBA	D	96	2.0 TDCi 4x4	05.2015 →	T8CD	D	96
2.3	07.2007 → 01.2015	SEBA	B	115	2.0 TDCi 4x4	05.2015 →	T8CL	D	96
2.5	03.2007 → 01.2015	HUBA	B	76	2.0 TDCi Bi-Turbo	05.2015 →	T9CA	D	96
<b>MONDEO IV Turnier (BA7)</b>				<b>MONDEO V Turnier (CF)</b>					
1.6 EcoBoost	02.2011 → 01.2015	JTBA	B	43	1.0 EcoBoost	02.2015 →	M1CA	B	8
1.6 EcoBoost	02.2011 → 01.2015	JTBB	B	43	1.0 EcoBoost	02.2015 →	M1CB	B	8
1.6 TDCi	02.2011 → 01.2015	T1BA	D	23	1.5 EcoBoost	09.2014 →	UNCA	B	43
1.6 TDCi	02.2011 → 01.2015	T1BB	D	23	1.5 EcoBoost	09.2014 →	UNCB	B	43
1.6 TDCi	02.2011 → 01.2015	T1BC	D	23	1.5 EcoBoost	09.2014 →	UNCE	B	43
1.6 Ti	03.2007 → 12.2010	PNBA	B	42	1.5 EcoBoost	09.2014 →	UNCF	B	43
1.6 Ti	03.2007 → 12.2012	RHBA	B	42	1.5 TDCi	03.2015 →	UGCC	D	11
1.8 TDCi	03.2007 → 12.2012	FFBA	D	73	1.5 TDCi	03.2015 →	XUCA	D	11
1.8 TDCi	06.2007 → 12.2012	KHBA	D	73	1.6 TDCi	09.2014 →	NGCA	D	26
1.8 TDCi	06.2007 → 12.2012	QYBA	D	73	1.6 TDCi	09.2014 →	U3CA	D	26
2.0	03.2007 → 01.2015	AOBA	B	115	2.0 TDCi	09.2014 →	T7CE	D	96
2.0	03.2007 → 01.2015	AOBC	B	115	2.0 TDCi	09.2014 →	T8CC	D	96
2.0	03.2007 → 01.2015	TBBA	B	115	2.0 TDCi	09.2014 →	T8CD	D	96
2.0	03.2007 → 01.2015	TBBB	B	115	2.0 TDCi	09.2014 →	T8CL	D	96
2.0 Flexifuel	03.2009 → 01.2015	TBBA	B	115	2.0 TDCi 4x4	02.2015 →	T7CE	D	96
2.0 Flexifuel	03.2009 → 01.2015	TBBB	B	115	2.0 TDCi 4x4	02.2015 →	T8CC	D	96
2.0 LPG	07.2009 → 01.2015	TBBA	B	115	2.0 TDCi 4x4	02.2015 →	T8CD	D	96
2.0 TDCi	03.2007 → 12.2012	AZBA	D	87	2.0 TDCi 4x4	02.2015 →	T8CL	D	96
2.0 TDCi	03.2007 → 12.2014	AZBC	D	87	2.0 TDCi Bi-Turbo	03.2015 →	T9CA	D	96
2.0 TDCi	03.2007 → 01.2015	QXBA	D	87	<b>ORION I (AFD)</b>				
2.0 TDCi	03.2007 → 01.2015	QXBB	D	87	1.3	07.1983 → 03.1986	JPA	B	50
2.0 TDCi	11.2007 → 01.2015	KLBA	D	87	1.6	07.1983 → 03.1986	LP1	B	50
2.0 TDCi	11.2007 → 01.2015	LPBA	D	87	1.6	07.1983 → 03.1986	LPA	B	50
2.0 TDCi	11.2007 → 01.2015	TYBA	D	89	1.6 D	02.1984 → 03.1986	LTA	D	56
2.0 TDCi	03.2010 → 01.2015	TXBA	D	93	1.6 i	07.1983 → 03.1986	LR1	B	51
2.0 TDCi	03.2010 → 01.2015	TXBB	D	93	1.6 i	07.1983 → 03.1986	LRA	B	51
2.2 TDCi	03.2008 → 10.2010	Q4BA	D	90	<b>ORION II (AFF)</b>				
2.2 TDCi	07.2010 → 01.2015	KNBA	D	96	1.3	12.1985 → 03.1989	JLA	B	17
2.3	07.2007 → 01.2015	SEBA	B	115	1.3	11.1986 → 07.1988	JPA	B	50
2.5	03.2007 → 12.2012	HUBA	B	76	1.4	12.1985 → 07.1990	FUA	B	35
<b>MONDEO V Hatchback (CE)</b>				<b>ORION III (GAL)</b>					
1.0 EcoBoost	02.2015 →	M1CA	B	8	1.4	01.1986 → 07.1990	FUC	B	35
1.0 EcoBoost	02.2015 →	M1CB	B	8	1.4	03.1986 → 07.1990	FUAA	B	34
1.5 EcoBoost	09.2014 →	UNCA	B	43	1.4 Cat	02.1987 → 07.1990	F6B	B	35
1.5 EcoBoost	09.2014 →	UNCB	B	43	1.4 Cat	02.1987 → 07.1990	F6D	B	35
1.5 EcoBoost	09.2014 →	UNCE	B	43	1.6	12.1985 → 07.1990	LUC	B	50
1.5 EcoBoost	09.2014 →	UNCF	B	43	1.6	03.1986 → 07.1990	LUG	B	50
1.5 TDCi	03.2015 →	UGCC	D	11	1.6 D	12.1985 → 01.1989	LTC	D	56
1.5 TDCi	03.2015 →	XUCA	D	11	1.6 i	02.1986 → 07.1990	LJB	B	51
1.6 TDCi	09.2014 →	NGCA	D	26	1.6 i	03.1986 → 07.1990	LRB	B	51
1.6 TDCi	09.2014 →	U3CA	D	26	1.6 i Cat	03.1986 → 07.1990	L4B	B	51
2.0 TDCi	09.2014 →	T7CE	D	96	1.8 D	01.1989 → 07.1990	RTA	D	70
2.0 TDCi	09.2014 →	T8CC	D	96	1.8 D	01.1989 → 07.1990	RTB	D	70
2.0 TDCi	09.2014 →	T8CD	D	96	<b>ORION III (GAL)</b>				
2.0 TDCi	09.2014 →	T8CL	D	96	1.4	07.1990 → 12.1993	F6F	B	35
2.0 TDCi 4x4	02.2015 →	T7CE	D	96	1.4	07.1990 → 12.1993	F6G	B	33
2.0 TDCi 4x4	02.2015 →	T8CC	D	96	1.4	07.1990 → 12.1993	FUH	B	35
					1.6	07.1990 → 12.1992	LUJ	B	54



				Pos					Pos
1.6	07.1990 → 12.1992	LUK	B	50	2.0	05.2006 → 12.2014	AOWB	B	115
1.6 i	07.1990 → 09.1992	LJF	B	48	2.0 TDCi	05.2006 → 12.2014	AZWA	D	87
1.6 i 16V	07.1992 → 12.1993	L1E	B	28	2.0 TDCi	05.2006 → 12.2014	AZWC	D	87
1.8 D	11.1990 → 12.1993	RTE	D	70	2.0 TDCi	05.2006 → 12.2014	QXWA	D	87
1.8 D	11.1990 → 12.1993	RTF	D	70	2.0 TDCi	05.2006 → 12.2014	QXWB	D	87
1.8 D	11.1990 → 12.1993	RTH	D	70	2.0 TDCi	05.2006 → 12.2014	QXWC	D	88
1.8 TD	03.1992 → 12.1993	RFD	D	69	2.0 TDCi	11.2007 → 12.2014	KLWA	D	87
1.8 TD	03.1992 → 12.1993	RFK	D	69	2.0 TDCi	03.2010 → 12.2014	TXWA	D	93
1.8 i 16V	01.1992 → 12.1993	RQB	B	57	2.2 TDCi	03.2008 → 12.2012	Q4WA	D	91
1.8 i 16V	02.1992 → 12.1993	RDA	B	57	2.2 TDCi	07.2010 → 12.2014	KNWA	D	95
2.0i 16V	08.1990 →	EDDB	B	82	2.5 ST	05.2006 → 12.2014	HUWA	B	76
2.0i 16V	08.1990 →	EDDC	B	83	<b>SCORPIO I (GAE, GGE)</b>				
2.0i 16V	08.1990 →	NGA	B	84	1.8	04.1985 → 02.1992	REC	B	113
<b>P 100 I</b>					2.0	04.1985 → 08.1989	N8D	B	100
1.6	04.1982 → 09.1987	LCR	B	119	2.0	04.1985 → 08.1989	NEL	B	135
<b>P 100 II</b>					2.0 i	04.1985 → 02.1992	NRA	B	135
1.8 TD	10.1987 → 12.1992	RFA	D	69	2.0 i	04.1985 → 02.1992	NRI	B	135
2.0	10.1987 → 12.1992	NAE	B	137	2.0 i	10.1985 → 12.1990	NRC	B	135
<b>PUMA</b>					2.0 i	05.1989 → 09.1994	N9D	B	101
1.0 EcoBoost	09.2019 →	B7JA	B	10	2.0 i	02.1992 → 09.1994	NRA	B	135
1.0 EcoBoost	09.2019 →	B7JB	B	10	2.0 i	02.1992 → 09.1994	NRI	B	135
1.0 EcoBoost	09.2019 →	M0JA	B	10	2.0 i	11.1992 → 09.1994	N9F	B	101
1.0 EcoBoost mHEV	09.2019 →	B7JA	B	10	2.4 i	09.1986 → 09.1988	ARC	B	79
1.0 EcoBoost mHEV	09.2019 →	B7JB	B	10	2.5 D	12.1985 → 02.1992	STR	D	144
1.0 EcoBoost mHEV	09.2019 →	BZJA	B	10	2.5 TD	06.1988 → 07.1993	SFA	D	144
<b>PUMA (EC_)</b>					2.5 TD	06.1988 → 07.1993	SFB	D	144
1.4 16V	11.1997 → 10.2000	FHD	B	28	2.9 i	09.1986 → 09.1994	BRC	B	138
1.4 16V	11.1997 → 10.2000	FHF	B	31	2.9 i 4x4	09.1986 → 09.1994	BRC	B	138
<b>RANGER (ER, EQ, R_)</b>					<b>SCORPIO I (GAE/GGE)</b>				
1.8	06.1999 → 02.2002	RKA	B	58	2.3 D	10.1982 → 12.1986	LXD 2	D	143
<b>RANGER (TKE)</b>					<b>SCORPIO I Saloon (GGE)</b>				
2.2 TDCi	04.2011 →	GBVAJPF	D	110	1.8	01.1986 → 10.1988	REC	B	113
2.2 TDCi	04.2011 →	GBVAJQW	D	110	1.9	11.1992 → 09.1993	NRA	B	135
2.2 TDCi	11.2011 →	GBVAJQJ	D	110	2.0 i	05.1989 → 02.1992	N9B	B	101
2.2 TDCi 4x4	04.2011 →	GBVAJQJ	D	110	2.0 i	05.1989 → 09.1994	N9D	B	101
2.2 TDCi 4x4	04.2011 →	GBVAJQW	D	110	2.0 i	02.1992 → 09.1994	N9F	B	101
2.2 TDCi 4x4	05.2015 →	GBVAJQJ	D	110	2.5 D	12.1989 → 12.1994	STR	D	144
3.2 TDCi	11.2011 →	SAFA	D	128	2.5 TD	06.1988 → 07.1993	SFA	D	144
3.2 TDCi 4x4	04.2011 →	SAFA	D	128	2.5 TD	06.1988 → 07.1993	SFB	D	144
<b>S-MAX (CJ, WA6)</b>					<b>SCORPIO I Turnier (GGE)</b>				
2.0 EcoBlue	07.2018 →	BCCC	D	80	2.0 i	10.1990 → 10.1992	N9A	B	101
2.0 EcoBlue	07.2018 →	YMCB	D	80	2.0 i	09.1991 → 09.1994	N9D	B	101
2.0 EcoBlue	07.2018 →	YNCA	D	80	2.0 i	09.1991 → 09.1994	N9F	B	101
2.0 EcoBlue 4x4	07.2018 →	BCCC	D	80	2.5 D	10.1990 → 08.1992	STR	D	144
2.0 EcoBlue 4x4	07.2018 →	YMCB	D	80	2.5 TD	09.1991 → 07.1993	SFA	D	144
2.0 TDCi	01.2015 → 06.2018	T7CJ	D	96	2.5 TD	09.1991 → 07.1993	SFB	D	144
2.0 TDCi	01.2015 → 06.2018	T7CK	D	96	<b>SCORPIO II (GFR, GGR)</b>				
2.0 TDCi	01.2015 → 06.2018	T7CL	D	96	2.0 i	10.1994 → 08.1998	NSD	B	101
2.0 TDCi	01.2015 → 06.2018	T8CH	D	96	<b>SCORPIO II Turnier (GNR, GGR)</b>				
2.0 TDCi	01.2015 → 06.2018	T8CI	D	96	2.0 i	10.1994 → 08.1998	NSD	B	101
2.0 TDCi	01.2015 → 06.2018	T8CJ	D	96	<b>SIERRA I Hatchback</b>				
2.0 TDCi	01.2015 → 06.2018	UFCA	D	96	1.6	01.1987 → 02.1993	LSE	B	66
2.0 TDCi	01.2015 → 06.2018	UFCB	D	96	<b>SIERRA I Hatchback (GBC)</b>				
2.0 TDCi 4x4	01.2015 → 06.2018	T7CJ	D	96	1.3	08.1982 → 12.1986	JCT	B	39
2.0 TDCi 4x4	01.2015 → 06.2018	T7CK	D	96	1.6	08.1982 → 12.1986	LCS	B	66
2.0 TDCi 4x4	01.2015 → 06.2018	T7CL	D	96	1.6	08.1982 → 12.1986	LCT	B	66
2.0 TDCi 4x4	01.2015 → 06.2018	T8CH	D	96	1.6	08.1982 → 12.1986	LSD	B	66
2.0 TDCi 4x4	01.2015 → 06.2018	T8CI	D	96	1.6	10.1982 → 02.1987	LSDA	B	66
2.0 TDCi 4x4	01.2015 → 06.2018	T8CJ	D	96	1.6	08.1984 → 12.1986	LSD	B	66
2.0 TDCi BI-Turbo	01.2015 → 06.2018	T9CB	D	96	1.8	10.1984 → 12.1986	REB	B	113
2.0 TDCi BI-Turbo	01.2015 → 06.2018	T9CC	D	96	2.0	08.1982 → 10.1984	NYT	B	78
<b>S-MAX (WA6)</b>					2.0	08.1982 → 12.1986	NET	B	135
1.6 EcoBoost	02.2011 → 12.2014	JTWA	B	43	2.0	10.1985 → 12.1986	NRD	B	135
1.6 EcoBoost	02.2011 → 12.2014	JTWB	B	43	2.0 i	03.1985 → 12.1986	NR2	B	135
1.6 TDCi	02.2011 → 12.2014	T1WA	D	25	2.0 i	03.1985 → 12.1986	NRB	B	135
1.6 TDCi	02.2011 → 12.2014	T1WB	D	25	2.3 D	08.1982 → 12.1986	YTT	D	143
1.8 TDCi	05.2006 → 12.2014	QYWA	D	73	<b>SIERRA II (GBG, GB4)</b>				
1.8 TDCi	01.2007 → 12.2010	FFWA	D	73	1.6	01.1987 → 02.1993	LSE	B	66
2.0	05.2006 → 12.2014	AOWA	B	115	1.6	01.1988 → 02.1993	LSF	B	66

**F**

				Pos					Pos
1.6 i	10.1989 → 02.1993	L6B	B	53	2.0 i	01.1987 → 02.1993	N4I	B	135
1.8	01.1987 → 05.1988	R2A	B	114	2.0 i	01.1987 → 02.1993	NE5	B	131
1.8	10.1987 → 05.1988	RED	B	113	2.0 i	01.1987 → 02.1993	NEJ	B	131
1.8	10.1987 → 09.1989	RED	B	113	2.0 i	05.1989 → 02.1993	N9C	B	101
1.8	10.1987 → 09.1989	REF	B	113	2.0 i	05.1989 → 02.1993	N9C	B	101
1.8	05.1988 → 02.1993	R2C	B	52	2.0 i Cat	01.1987 → 02.1993	N4B	B	131
1.8	05.1988 → 02.1993	R6A	B	52	2.3 D	01.1987 → 02.1993	YTR	D	143
1.8 TD	08.1988 → 02.1993	RFA	D	69	<b>SIERRA Turnier (BNC)</b>				
1.8 TD	08.1988 → 02.1993	RFB	D	69	1.6	08.1982 → 12.1986	LCS	B	66
1.8 TD	08.1988 → 02.1993	RFL	D	69	1.6	08.1982 → 12.1986	LCT	B	66
2.0	01.1987 → 12.1989	NES	B	131	1.6	08.1982 → 12.1986	LSD	B	66
2.0	07.1989 → 12.1992	N8A	B	100	1.8	10.1984 → 12.1986	REB	B	113
2.0	12.1989 → 02.1993	N8C	B	100	2.0	08.1982 → 10.1984	NYT	B	78
2.0 4x4	01.1990 → 02.1993	N9C	B	101	2.0	08.1982 → 12.1986	NET	B	135
2.0 4x4	01.1990 → 02.1993	N9C	B	101	2.0	03.1985 → 12.1986	NR2	B	135
2.0 i	01.1987 → 12.1989	NE5	B	131	2.0	03.1985 → 12.1986	NRB	B	135
2.0 i	01.1987 → 12.1989	NEJ	B	131	2.0	10.1985 → 12.1986	NRD	B	135
2.0 i	01.1987 → 02.1993	N4A	B	135	2.3 D	08.1982 → 12.1986	YTT	D	143
2.0 i	01.1987 → 02.1993	N4I	B	135	<b>TAUNUS (GBTK)</b>				
2.0 i	01.1990 → 02.1993	N9A	B	101	1300	01.1970 → 05.1975	JAC	B	38
2.0 i	01.1990 → 02.1993	N9C	B	101	2000	08.1973 → 02.1976	NEG	B	131
2.0 i	01.1990 → 02.1993	N9C	B	101	<b>TAUNUS (GBTS, GBFS, CBTS)</b>				
2.0 i Cat	01.1987 → 02.1993	N4B	B	131	1.3	05.1975 → 07.1979	JAC	B	38
2.3 D	01.1987 → 09.1989	YTR	D	143	1.3	01.1976 → 07.1979	JAC	B	38
2.3 D	01.1987 → 09.1989	YTT	D	143	1.3 (CBTS)	09.1976 → 07.1979	JAC	B	38
<b>SIERRA II Hatchback (GBC, GBG)</b>					2.0	05.1975 → 07.1979	NYR	B	78
1.6	01.1987 → 02.1993	LSE	B	66	2.0	08.1976 → 07.1979	NEG	B	131
1.6	01.1988 → 02.1993	LSF	B	66	2.0	09.1976 → 07.1979	NEG	B	131
1.6 i	10.1989 → 02.1993	L6B	B	53	<b>TAUNUS 17M II (31F)</b>				
1.8	01.1987 → 05.1988	R2A	B	114	1.7	07.1967 → 04.1974	MY	B	129
1.8	10.1987 → 05.1988	RED	B	113	1.7	12.1967 → 04.1974	MY	B	129
1.8	10.1987 → 05.1988	RED	B	113	<b>TAUNUS 17M II (32F)</b>				
1.8	10.1987 → 05.1988	REF	B	113	1.7	07.1967 → 04.1974	MY	B	129
1.8	05.1988 → 02.1993	R2C	B	52	1.7	08.1968 → 04.1974	MY	B	129
1.8	05.1988 → 02.1993	R6A	B	52	<b>TAUNUS 17M II Coupe (33F)</b>				
1.8 TD	08.1988 → 02.1993	RFA	D	69	1.7	07.1967 → 04.1974	MY	B	129
1.8 TD	08.1988 → 02.1993	RFB	D	69	1.7	08.1968 → 04.1974	MY	B	129
1.8 TD	08.1988 → 02.1993	RFL	D	69	<b>TAUNUS 17M II Turnier (35F)</b>				
2.0	01.1987 → 12.1989	NES	B	131	1.7	01.1968 → 04.1974	MY	B	129
2.0	12.1989 → 02.1993	N8C	B	100	<b>TAUNUS 17M II Turnier (36F)</b>				
2.0 4x4	10.1991 → 03.1993	N9C	B	101	1.7	08.1968 → 04.1974	MY	B	129
2.0 i	01.1987 → 02.1993	N4A	B	135	<b>TAUNUS Coupe</b>				
2.0 i	01.1987 → 02.1993	N4I	B	135	1.3	01.1976 → 07.1979	JAC	B	38
2.0 i	01.1987 → 02.1993	NE5	B	131	<b>TAUNUS Coupe (GBCK)</b>				
2.0 i	01.1987 → 02.1993	NEJ	B	131	2000	08.1973 → 02.1976	NEE	B	131
2.0 i	06.1989 → 02.1993	N8A	B	100	<b>TAUNUS III Turnier (GBNS)</b>				
2.0 i	06.1989 → 02.1993	N9B	B	101	2.0	07.1979 → 07.1982	NER	B	135
2.0 i	06.1989 → 02.1993	N9C	B	101	2.0	07.1979 → 07.1982	NWR	B	78
2.0 i Cat	01.1987 → 02.1993	N4B	B	131	<b>TAUNUS Turnier (GBNS)</b>				
2.3 D	01.1987 → 09.1989	YTR	D	143	1.3	05.1975 → 07.1979	JAC	B	38
<b>SIERRA II Turnier (BNG)</b>					1.3	12.1975 → 07.1979	JAC	B	38
1.6	01.1987 → 02.1993	LSE	B	66	1.3	01.1976 → 07.1979	JAC	B	38
1.6	01.1988 → 02.1993	LSF	B	66	2.0	05.1975 → 07.1979	NYR	B	78
1.6 i	10.1989 → 02.1993	L6B	B	53	2.0	08.1976 → 07.1979	NEG	B	131
1.8	01.1987 → 05.1988	R2A	B	114	<b>TAUNUS V (GBS, GBNS)</b>				
1.8	10.1987 → 05.1988	RED	B	113	2.0	07.1979 → 07.1982	NER	B	135
1.8	10.1987 → 05.1988	RED	B	113	2.0	07.1979 → 07.1982	NER	B	135
1.8	10.1987 → 05.1988	REF	B	113	2.0	07.1979 → 07.1982	NWR	B	78
1.8	05.1988 → 02.1993	R2C	B	52	<b>TELSTAR</b>				
1.8	05.1988 → 02.1993	R6A	B	52	2.0 D (AUS)	03.1983 → 1987	RF	D	103
1.8 TD	08.1988 → 02.1993	RFA	D	69	<b>TOURNEO CONNECT</b>				
1.8 TD	08.1988 → 02.1993	RFB	D	69	1.8 16V	06.2002 → 12.2013	EYPA	B	59
1.8 TD	08.1988 → 02.1993	RFL	D	69	1.8 TDCi	06.2002 → 12.2013	HCPA	D	73
1.9	10.1988 → 09.1991	N8A	B	100	1.8 TDCi	06.2002 → 12.2013	HCPB	D	73
2.0	01.1987 → 12.1989	NES	B	131	1.8 TDCi	06.2002 → 12.2013	R3PA	D	74
2.0	12.1989 → 02.1993	N8C	B	100	1.8 TDCi	06.2002 → 12.2013	RWPE	D	74
2.0 4x4	05.1989 → 02.1993	N9C	B	101	1.8 TDCi	06.2002 → 12.2013	RWPF	D	74
2.0 4x4	02.1990 → 02.1993	N9C	B	101	1.8 TDCi	08.2006 → 12.2013	RWPA	D	73
2.0 i	01.1987 → 02.1993	N4A	B	135	1.8 TDCi	08.2006 → 12.2013	RWPC	D	74

			Pos				Pos		
1.8 TDCi	08.2006 → 12.2013	RWPD	D	74	1.5 TDCi	01.2014 →	UGCB	D	11
1.8 TDCi /TDDi /DI	06.2002 → 12.2013	BHPA	D	73	1.5 TDCi	01.2014 →	XUCC	D	11
1.8 TDCi /TDDi /DI	06.2002 → 12.2013	P7PA	D	73	1.5 TDCi	01.2014 →	XUCD	D	11
1.8 TDCi /TDDi /DI	06.2002 → 12.2013	P7PB	D	74	1.6 TDCi	01.2014 →	T3CA	D	25
1.8 TDCi /TDDi /DI	06.2002 → 12.2013	R2PA	D	73	1.6 TDCi	01.2014 →	T3CB	D	26
<b>TOURNEO CONNECT / GRAND TOURNEO CONNECT V408 MPV</b>					1.6 TDCi	01.2014 →	T3CC	D	26
1.0 EcoBoost	11.2013 →	M2GA	B	8	<b>B-MAX Van (JK)</b>				
1.0 EcoBoost	11.2013 →	M2GB	B	8	1.0 EcoBoost	08.2012 →	M1JA	B	8
1.0 EcoBoost	11.2013 →	SFCB	B	8	1.0 EcoBoost	10.2012 →	M1JE	B	8
1.0 EcoBoost	05.2018 →	B3GA	B	10	1.0 EcoBoost	10.2012 →	M1JH	B	8
1.5 TDCi	05.2015 →	XVGA	D	11	1.0 EcoBoost	10.2012 →	SFJA	B	9
1.5 TDCi	05.2015 →	XVGB	D	11	1.0 EcoBoost	10.2012 →	SFJB	B	9
1.5 TDCi	05.2015 →	XVGC	D	11	1.0 EcoBoost	10.2012 →	SFJC	B	9
1.5 TDCi	05.2015 →	XWGA	D	11	1.0 EcoBoost	10.2012 →	SFJD	B	9
1.5 TDCi	05.2015 →	XWGB	D	11	1.5 TDCi	10.2012 →	UGJC	D	12
1.5 TDCi	05.2015 →	XWGC	D	11	1.5 TDCi	10.2012 →	UGJG	D	11
1.5 TDCi	05.2015 →	XXGA	D	11	1.5 TDCi	10.2012 →	XUJA	D	11
<b>TOURNEO COURIER B460 MPV</b>					1.5 TDCi	10.2012 →	XUJB	D	11
1.0 EcoBoost	02.2014 →	SFCA	B	8	1.5 TDCi	04.2015 →	XVJA	D	11
1.0 EcoBoost	02.2014 →	SFCB	B	8	1.5 TDCi	04.2015 →	XVJC	D	11
1.0 EcoBoost	02.2014 →	SFCC	B	8	1.6 TDCi	10.2012 →	T3JB	D	26
1.0 EcoBoost	02.2014 →	SFCD	B	8	1.6 Ti	10.2012 →	IQJA	B	43
1.5 EcoBlue	04.2018 →	XXCA	D	11	<b>C-MAX II Van</b>				
1.5 EcoBlue	04.2018 →	XXCB	D	11	1.0 EcoBoost	10.2012 →	B7DA	B	10
1.5 EcoBlue	04.2018 →	XXCC	D	11	1.0 EcoBoost	10.2012 →	M1DA	B	9
1.5 TDCi	02.2014 →	UGCA	D	12	1.0 EcoBoost	10.2012 →	M1DD	B	9
1.5 TDCi	02.2014 →	UGCB	D	11	1.0 EcoBoost	10.2012 →	M2DA	B	8
1.5 TDCi	02.2014 →	XUCC	D	11	1.0 EcoBoost	10.2012 →	M2DC	B	8
1.5 TDCi	02.2014 →	XUCD	D	11	1.5 EcoBoost	03.2015 →	M8DB	B	43
1.5 TDCi	05.2015 →	XVCA	D	11	1.5 EcoBoost	03.2015 →	M9DB	B	43
1.5 TDCi	05.2015 →	XVCB	D	11	1.5 TDCi	03.2015 →	XWDA	D	12
1.5 TDCi	05.2015 →	XVCC	D	11	1.5 TDCi	03.2015 →	XWDB	D	12
1.5 TDCi	04.2018 →	XWCA	D	11	1.5 TDCi	03.2015 →	XWDC	D	12
1.5 TDCi	04.2018 →	XWCB	D	11	1.5 TDCi	03.2015 →	XWDD	D	12
1.6 TDCi	02.2014 →	T3CA	D	25	1.5 TDCi	03.2015 →	XWDE	D	11
1.6 TDCi	02.2014 →	T3CB	D	26	1.5 TDCi ECONetic	03.2015 →	AEDA	D	12
1.6 TDCi	02.2014 →	T3CC	D	26	1.6 EcoBoost	12.2010 →	JQDA	B	43
<b>TRANSIT CONNECT MPV</b>					1.6 EcoBoost	12.2010 →	JQDB	B	43
1.5 TDCi	05.2015 →	XVGA	D	11	1.6 EcoBoost	12.2010 →	JTDA	B	43
1.5 TDCi	05.2015 →	XVGB	D	11	1.6 EcoBoost	12.2010 →	JTDB	B	43
1.5 TDCi	05.2015 →	XVGC	D	11	1.6 TDCi	12.2010 →	T1DA	D	23
1.5 TDCi	05.2015 →	XWGA	D	11	1.6 TDCi	12.2010 →	T1DB	D	23
1.5 TDCi	05.2015 →	XWGB	D	11	1.6 TDCi	12.2010 →	T3DA	D	23
1.5 TDCi	05.2015 →	XWGC	D	11	1.6 TDCi	12.2010 →	T3DB	D	23
1.5 TDCi	05.2015 →	XXGA	D	11	1.6 Ti	10.2010 →	IQDB	B	43
<b>TRANSIT COURIER B460 MPV</b>					2.0 TDCi	12.2010 →	TXDB	D	94
1.0 EcoBoost	02.2014 →	SFCA	B	8	2.0 TDCi	02.2011 →	TYDA	D	94
1.0 EcoBoost	02.2014 →	SFCB	B	8	2.0 TDCi	02.2011 →	UFDB	D	94
1.0 EcoBoost	02.2014 →	SFCC	B	8	2.0 TDCi	03.2015 →	T7DB	D	96
1.0 EcoBoost	02.2014 →	SFCD	B	8	2.0 TDCi	03.2015 →	T8DE	D	96
1.5 EcoBlue	04.2018 →	XXCA	D	11	<b>ECONOVAN (KBA, KCA)</b>				
1.5 EcoBlue	04.2018 →	XXCB	D	11	2.0 D	03.1986 → 03.1992	RF	D	103
1.5 EcoBlue	04.2018 →	XXCC	D	11	<b>ECONOVAN Van (KAA)</b>				
1.5 TDCi	02.2014 →	UGCA	D	12	2.0 D	03.1986 → 03.1992	RF	D	103
1.5 TDCi	02.2014 →	UGCB	D	11	<b>ESCORT III Express (AVA)</b>				
1.5 TDCi	02.2014 →	XUCC	D	11	1.1	03.1981 → 02.1986	GLB	B	18
1.5 TDCi	02.2014 →	XUCD	D	11	1.3	03.1981 → 02.1986	JPA	B	50
1.5 TDCi	05.2015 →	XVCA	D	11	1.6 D	02.1984 → 02.1986	LTA	D	56
1.5 TDCi	05.2015 →	XVCB	D	11	<b>ESCORT IV Express (AVF)</b>				
1.5 TDCi	05.2015 →	XVCC	D	11	1.3	02.1986 → 03.1989	JLA	B	17
1.5 TDCi	04.2018 →	XWCA	D	11	1.4 i	02.1986 → 07.1990	F6B	B	35
1.5 TDCi	04.2018 →	XWCB	D	11	1.4 i	02.1986 → 07.1990	F6D	B	35
1.6 TDCi	02.2014 →	T3CA	D	25	1.4 i	02.1986 → 07.1990	FUC	B	35
1.6 TDCi	02.2014 →	T3CB	D	26	1.6	02.1986 → 07.1990	LUC	B	50
1.6 TDCi	02.2014 →	T3CC	D	26	1.6 D	02.1986 → 07.1990	LTA	D	56
					1.8 D	07.1988 → 07.1990	RTA	D	70
<b>(GRANT) TOURNEO CONNECT II</b>					1.8 D	07.1988 → 07.1990	RTB	D	70
1.5 TDCi	01.2014 →	UGCA	D	12	<b>ESCORT V Express (AVF)</b>				
					1.4	07.1990 → 12.1994	F6F	B	35

F

				Pos					Pos
1.4	07.1990 → 12.1994	F6G	B	33	1.4 TDCi	07.2010 →	KVJA	D	14
1.8 D	07.1990 → 12.1994	RTA	D	70	1.5 TDCi	10.2012 →	UGJC	D	12
1.8 D	07.1990 → 12.1994	RTE	D	70	1.5 TDCi	10.2012 →	XUJA	D	11
1.8 D	07.1990 → 12.1994	RTF	D	70	1.5 TDCi	10.2012 →	XUJB	D	11
1.8 D	07.1990 → 12.1994	RTH	D	70	1.5 TDCi	05.2015 →	XVJB	D	11
<b>ESCORT VI Estate Van (AVL)</b>					1.5 TDCi	05.2015 →	XVJC	D	11
1.4	01.1995 → 08.2000	F4B	B	35	1.6 ST	03.2013 →	JTJA	B	43
1.8 D	01.1995 → 08.2000	RTE	D	70	1.6 ST	03.2013 →	JTJB	B	43
1.8 D	01.1995 → 08.2000	RTF	D	70	1.6 TDCi	01.2009 →	HHJC	D	22
1.8 D	01.1995 → 08.2000	RTH	D	70	1.6 TDCi	01.2009 →	HHJD	D	22
1.8 TD	01.1995 → 08.2000	RFD	D	69	1.6 TDCi	01.2009 →	HHJE	D	22
1.8 TD	01.1995 → 08.2000	RFK	D	69	1.6 TDCi	02.2010 →	T3JA	D	24
1.8 TD	01.1995 → 08.2000	RFS	D	71	1.6 TDCi	02.2010 →	TZJA	D	23
1.8 Turbo D	12.1995 → 06.2001	RVA	D	72	1.6 TDCi	02.2010 →	TZJB	D	23
<b>FIESTA Box Body/MPV (F3L, F5L)</b>					1.6 Ti-VCT	10.2008 → 12.2012	HXJA	B	42
1.8 D	09.1991 → 02.1996	RTC	D	70	1.6 Ti-VCT	10.2008 → 12.2012	HXJB	B	42
1.8 D	09.1991 → 02.1996	RTD	D	70	<b>FIESTA VII Van</b>				
1.8 D	09.1991 → 02.1996	RTG	D	70	1.0 EcoBoost	09.2018 →	M1JL	B	8
<b>FIESTA Box Body/MPV (J5_, J3_)</b>					1.0 EcoBoost	09.2018 →	M1JM	B	8
1.4 i	04.1996 → 10.1999	FHA	B	31	1.0 EcoBoost	04.2019 →	SFJE	B	8
1.8 D	02.1996 → 04.2002	RTJ	D	70	1.0 EcoBoost	04.2019 →	SFJF	B	8
1.8 D	02.1996 → 04.2002	RTK	D	70	1.0 EcoBoost	04.2019 →	SFJH	B	8
1.8 DI	09.2000 → 08.2003	RTN	D	73	1.0 EcoBoost	04.2019 →	SFJJ	B	8
1.8 DI	09.2000 → 08.2003	RTP	D	73	1.0 EcoBoost	04.2019 →	SFJK	B	8
<b>FIESTA Box Body/MPV (JV_)</b>					1.0 EcoBoost	04.2019 →	SFJN	B	8
1.4	08.1998 → 04.2002	FHA	B	31	1.0 EcoBoost	04.2019 →	SFJP	B	8
D 1.8	05.1998 → 04.2002	RTJ	D	70	1.0 EcoBoost	04.2019 →	YYJE	B	8
D 1.8	05.1998 → 04.2002	RTK	D	70	1.5 TDCi	09.2018 →	XWJA	D	11
TD 1.8	03.2000 → 08.2003	RTN	D	73	1.5 TDCi	09.2018 →	XWJB	D	11
TD 1.8	03.2000 → 08.2003	RTP	D	73	1.5 TDCi	09.2018 →	XWJC	D	11
TD 1.8	03.2000 → 08.2003	RTQ	D	73	1.5 TDCi	04.2019 →	XUJC	D	11
<b>FIESTA Hatchback Van (FVD)</b>					1.5 TDCi	04.2019 →	XUJD	D	11
1.4	09.1986 → 09.1989	F6A	B	36	1.5 TDCi	04.2019 →	XUJE	D	11
1.6 D	09.1983 → 09.1989	LTB	D	56	1.5 TDCi	04.2019 →	XUJF	D	11
1.8 D (FVJ)	03.1989 → 12.1995	RTC	D	70	1.5 TDCi	04.2019 →	XUJG	D	11
1.8 D (FVJ)	03.1989 → 12.1995	RTD	D	70	1.5 TDCi	04.2019 →	XUJK	D	11
1.8 D (FVJ)	03.1989 → 12.1995	RTG	D	70	1.5 TDCi	04.2019 →	XUJL	D	11
<b>FIESTA Hatchback Van (WFVT)</b>					1.5 TDCi	04.2019 →	XUJM	D	11
1.1 (WFVT)	10.1977 → 11.1986	GL1	B	18	1.5 TDCi	04.2019 →	XUJN	D	11
1.1 (WFVT)	10.1977 → 11.1986	GLA	B	16	<b>FOCUS I Estate Van (DNW)</b>				
<b>FIESTA V Van</b>					1.6	04.1999 → 03.2005	FYDA	B	40
1.4	05.2002 → 09.2005	FXJA	B	32	1.6	04.1999 → 03.2005	FYDB	B	40
1.4 TDCi	10.2003 → 12.2010	F6JA	D	13	1.6	04.1999 → 03.2005	FYDC	B	40
1.4 TDCi	10.2003 → 12.2010	F6JB	D	13	1.6	04.1999 → 03.2005	FYDD	B	40
1.6 TDCi	04.2007 → 09.2009	HHJA	D	22	1.8	04.1999 → 03.2005	EYDB	B	59
1.6 TDCi	04.2007 → 09.2009	HHJB	D	22	1.8	04.1999 → 03.2005	EYDC	B	59
1.6 TDCi	04.2007 → 09.2009	HHJD	D	22	1.8 TDCi	08.2001 → 03.2005	F9DA	D	73
<b>FIESTA VI Van</b>					1.8 TDCi	08.2001 → 03.2005	F9DB	D	73
1.0	10.2012 →	P4JA	B	8	1.8 TDCi	08.2002 → 03.2005	FFDA	D	73
1.0	10.2012 →	P4JB	B	8	1.8 TDDi	08.1998 → 03.2005	C9DA	D	73
1.0	10.2012 →	P4JC	B	8	1.8 TDDi	08.1998 → 03.2005	C9DB	D	73
1.0	10.2012 →	P4JD	B	8	1.8 TDDi	08.1998 → 03.2005	C9DC	D	73
1.0	01.2013 →	XMJA	B	8	1.8 TDDi	08.1999 → 03.2005	BHDA	D	73
1.0	01.2013 →	XMJB	B	8	1.8 TDDi	08.1999 → 03.2005	BHDB	D	73
1.0 EcoBoost	09.2012 →	M1JE	B	8	<b>FOCUS II Estate Van</b>				
1.0 EcoBoost	09.2012 →	M1JH	B	8	1.4	09.2005 → 07.2011	ASDA	B	32
1.0 EcoBoost	01.2013 →	SFJA	B	9	1.4	09.2005 → 07.2011	ASDB	B	32
1.0 EcoBoost	01.2013 →	SFJB	B	9	1.6	09.2005 → 07.2011	HWDA	B	42
1.0 EcoBoost	01.2013 →	SFJC	B	9	1.6 TDCi	07.2004 → 07.2011	G8DA	D	22
1.0 EcoBoost	01.2013 →	SFJD	B	9	1.6 TDCi	11.2004 → 07.2011	G8DC	D	22
1.0 EcoBoost	05.2014 →	YYJA	B	8	1.6 TDCi	11.2004 → 07.2011	MTDA	D	22
1.0 EcoBoost	05.2014 →	YYJB	B	8	1.6 TDCi	09.2005 → 07.2011	HHDA	D	22
1.25	01.2009 →	SNJA	B	7	1.6 Ti-VCT	09.2005 → 07.2011	HXDA	B	42
1.25	01.2009 →	SNJB	B	7	1.6 Ti-VCT	09.2005 → 07.2011	HXDB	B	42
1.4	10.2008 → 12.2012	SPJA	B	32	1.8 Flexifuel	06.2009 → 07.2011	QQDA	B	75
1.4	10.2008 → 12.2012	SPJC	B	32	2.0 TDCi	09.2005 → 07.2011	G6DB	D	87
1.4 TDCi	01.2009 →	F6JB	D	13	<b>FOCUS III Estate Van</b>				
1.4 TDCi	01.2009 →	F6JD	D	15	1.0 EcoBoost	02.2012 →	M1DA	B	9
1.4 TDCi	07.2010 →	F6JD	D	15	1.0 EcoBoost	02.2012 →	M1DC	B	9



				Pos					Pos
1.0 EcoBoost	02.2012 →	M1DD	B	9	TDCi	01.2007 → 06.2015	KLWA	D	87
1.0 EcoBoost	02.2012 →	M2DA	B	8	TDCi	03.2010 → 06.2015	TXWA	D	93
1.0 EcoBoost	02.2012 →	M2DB	B	8	TDCi	03.2013 → 06.2015	KNWA	D	95
1.0 EcoBoost	02.2012 →	M2DC	B	8	TDCi	03.2013 → 06.2015	T1WA	D	25
1.0 EcoBoost	02.2012 →	SFDA	B	8	TDCi	03.2013 → 06.2015	T1WB	D	25
1.0 EcoBoost	02.2012 →	SFDB	B	8	<b>GALAXY MK III VAN (CK)</b>				
1.5 EcoBoost	09.2014 →	M8DA	B	43	2.0 EcoBlue	03.2019 →	YMCB	D	80
1.5 EcoBoost	09.2014 →	M8DB	B	43	2.0 EcoBlue AWD	03.2019 →	BCCC	D	80
1.5 EcoBoost	09.2014 →	M9DA	B	43	<b>GRAND C-MAX Van</b>				
1.5 EcoBoost	09.2014 →	M9DB	B	43	1.0 EcoBoost	10.2012 →	B3DA	B	10
1.5 TDCi	09.2014 →	XWDA	D	12	1.0 EcoBoost	10.2012 →	B7DA	B	10
1.5 TDCi	09.2014 →	XWDB	D	12	1.0 EcoBoost	10.2012 →	M1DA	B	9
1.5 TDCi	09.2014 →	XWDC	D	12	1.0 EcoBoost	10.2012 →	M1DD	B	9
1.5 TDCi	09.2014 →	XWDD	D	12	1.0 EcoBoost	10.2012 →	M2DA	B	8
1.5 TDCi	09.2014 →	XXDA	D	12	1.0 EcoBoost	10.2012 →	M2DC	B	8
1.5 TDCi	09.2014 →	XXDC	D	12	1.5 EcoBoost	03.2015 →	M8DB	B	43
1.5 TDCi ECOnetic	09.2014 →	XXDB	D	12	1.5 TDCi	03.2015 →	XWDA	D	12
2.0 TDCi	11.2014 →	T7DB	D	96	1.5 TDCi	03.2015 →	XWDB	D	12
<b>FOCUS III Hatchback Van</b>					1.5 TDCi	03.2015 →	XWDC	D	12
1.0 EcoBoost	02.2012 →	M1DA	B	9	1.5 TDCi	03.2015 →	XWDD	D	12
1.0 EcoBoost	02.2012 →	M1DC	B	9	1.5 TDCi	03.2015 →	XWDE	D	11
1.0 EcoBoost	02.2012 →	M1DD	B	9	1.6 EcoBoost	12.2010 →	JQDA	B	43
1.0 EcoBoost	02.2012 →	M2DA	B	8	1.6 EcoBoost	12.2010 →	JQDB	B	43
1.0 EcoBoost	02.2012 →	M2DB	B	8	1.6 EcoBoost	12.2010 →	JTDA	B	43
1.0 EcoBoost	02.2012 →	M2DC	B	8	1.6 EcoBoost	12.2010 →	JTDB	B	43
1.0 EcoBoost	02.2012 →	SFDA	B	8	1.6 TDCi	12.2010 →	T1DA	D	23
1.0 EcoBoost	02.2012 →	SFDB	B	8	1.6 TDCi	12.2010 →	T1DB	D	23
1.5 EcoBoost	09.2014 →	M8DA	B	43	1.6 TDCi	12.2010 →	T3DA	D	23
1.5 EcoBoost	09.2014 →	M8DB	B	43	1.6 TDCi	12.2010 →	T3DB	D	23
1.5 EcoBoost	09.2014 →	M9DA	B	43	2.0 TDCi	02.2011 →	TYDA	D	94
1.5 EcoBoost	09.2014 →	M9DB	B	43	2.0 TDCi	12.2010 →	TXDB	D	94
1.5 TDCi	09.2014 →	XWDA	D	12	2.0 TDCi	12.2010 →	UFDB	D	94
1.5 TDCi	09.2014 →	XWDB	D	12	2.0 TDCi	03.2015 →	T7DB	D	96
1.5 TDCi	09.2014 →	XWDC	D	12	2.0 TDCi	03.2015 →	T8DE	D	96
1.5 TDCi	09.2014 →	XWDD	D	12	<b>KUGA I VAN</b>				
1.5 TDCi	09.2014 →	XWDE	D	11	2.5	02.2008 → 11.2012	HYDB	B	76
1.5 TDCi	09.2014 →	XXDA	D	12	2.5	02.2008 → 11.2012	HYDC	B	76
1.5 TDCi	09.2014 →	XXDC	D	12	TDCi	03.2010 → 11.2012	UFDA	D	92
1.5 TDCi ECOnetic	09.2014 →	AEDA	D	12	TDCi 4x4	03.2010 → 11.2012	TXDA	D	92
1.5 TDCi ECOnetic	09.2014 →	XXDB	D	12	TDCi 4x4	03.2010 → 11.2012	UFDA	D	92
1.6 EcoBoost	11.2011 → 06.2014	JQDA	B	43	<b>KUGA II VAN</b>				
1.6 EcoBoost	11.2011 → 06.2014	JQDB	B	43	1.5 EcoBoost	09.2014 →	M8MA	B	43
1.6 EcoBoost	11.2011 → 06.2014	JTDA	B	43	1.5 TDCi	01.2019 →	XWMB	D	11
1.6 EcoBoost	11.2011 → 06.2014	JTDB	B	43	1.5 TDCi	01.2019 →	XWMC	D	11
1.6 TDCi	01.2011 →	T3DA	D	23	2.0 TDCi	09.2014 →	T7MA	D	96
1.6 TDCi	01.2011 →	T3DB	D	23	2.0 TDCi	09.2014 →	T7MB	D	96
1.6 TDCi	02.2012 →	T1DA	D	23	2.0 TDCi 4x4	09.2014 →	T7MA	D	96
1.6 TDCi	02.2012 →	T1DB	D	23	2.0 TDCi 4x4	09.2014 →	T7MB	D	96
1.6 Ti	01.2011 →	IQDB	B	43	2.0 TDCi 4x4	09.2014 →	T8MA	D	96
2.0 TDCi	01.2011 → 06.2014	TXDB	D	94	2.0 TDCi 4x4	09.2014 →	T8MB	D	96
2.0 TDCi	01.2011 → 06.2014	TYDA	D	94	<b>MONDEO IV Van</b>				
2.0 TDCi	01.2011 → 06.2014	UFDB	D	94	1.6 EcoBoost	11.2010 → 09.2014	JTBA	B	43
2.0 TDCi	11.2014 →	T7DB	D	96	1.6 TDCi	03.2013 → 09.2014	T1BA	D	23
<b>GALAXY MK I VAN (WGR)</b>					1.6 TDCi	03.2013 → 09.2014	T1BB	D	23
1.9 TDi	09.1996 → 08.1999	AHU	D	44	1.6 TDCi	03.2013 → 09.2014	T1BC	D	23
1.9 TDi	09.1999 → 03.2006	ANU	D	46	2.0	03.2007 → 09.2014	AOBC	B	115
1.9 TDi	05.2000 → 03.2006	AUY	D	46	2.0 TDCi	03.2007 → 09.2014	QXBB	D	87
2.0	03.1996 → 03.2006	NSE	B	101	2.0 TDCi	11.2007 → 09.2014	KLBA	D	87
2.0	03.1996 → 03.2006	ZVSA	B	101	2.0 TDCi	03.2010 → 09.2014	TXBA	D	93
2.8	11.1995 → 07.2000	AAA	B	64	2.2 TDCi	03.2013 → 09.2014	KNBA	D	96
2.8	05.2000 → 03.2006	AYL	B	65	<b>S-MAX VAN (WA6)</b>				
<b>GALAXY MK II VAN (WA6)</b>					1.6	02.2011 → 12.2014	JTWA	B	43
2.0	05.2006 → 06.2015	AOWA	B	115	2.0	03.2010 → 12.2014	AODE	B	115
EcoBoost	02.2011 → 06.2015	JTWA	B	43	2.0 TDCi	03.2010 → 12.2014	KLWA	D	87
EcoBoost	02.2011 → 06.2015	JTWB	B	43	2.0 TDCi	03.2010 → 12.2014	QXWA	D	87
TDCi	05.2006 → 06.2015	QXWA	D	87	2.0 TDCi	03.2010 → 12.2014	QXWB	D	87
TDCi	05.2006 → 06.2015	QXWB	D	87	2.0 TDCi	03.2010 → 12.2014	QXWC	D	88
TDCi	05.2006 → 06.2015	QXWC	D	88	2.0 TDCi	03.2010 → 12.2014	TXWA	D	93
TDCi	11.2006 → 06.2015	AZWA	D	87	<b>TOURNEO</b>				

**F**



		Pos			Pos
2.0 DI 16V 08.2000 →	ABFA D	104	2.5 TD (ECL, EDL, EDS, 07.1994 → 03.2000 ESL, ESS, EUS)	4EC D	142
2.0i 16V 08.1994 → 07.2000	NSF B	101	2.5 TD (ECL, EDS, EDL, 09.1991 → 07.1994 EGL, ESS, EUS)	4EA D	140
2.0i 16V 08.1994 → 07.2000	NSG B	101	2.9 i 01.1991 → 09.1994	BRT B	139
<b>TOURNEO CUSTOM V362 Bus (F3)</b>			<b>TRANSIT Bus (FD_, FB_, FS_, FZ_, FC_)</b>		
2.0 EcoBlue 12.2015 →	YLF6 D	81	2.0 09.2000 → 03.2006	NSF B	101
2.0 EcoBlue 12.2015 →	YLFS D	81	2.0 DI (F_E_, F_F_, F_G_) 08.2000 → 05.2006	ABFA D	104
2.0 EcoBlue 12.2015 →	YMF6 D	81	2.0 DI (F_E_, F_F_, F_G_) 08.2000 → 05.2006	D3FA D	104
2.0 EcoBlue 12.2015 →	YNF6 D	81	2.0 DI (F_E_, F_F_, F_G_) 08.2000 → 05.2006	F3FA D	104
2.0 EcoBlue 12.2015 →	YNF6 D	81	2.0 TDCi (F_F_, F_E_, F_G_) 08.2002 → 05.2006	FIFA D	104
2.0 EcoBlue 05.2019 →	BJFA D	81	2.2 TDCi 04.2006 → 08.2014	P8FA D	107
2.0 EcoBlue 05.2019 →	BJFB D	81	2.2 TDCi 04.2006 → 08.2014	P8FB D	107
2.0 EcoBlue 05.2019 →	BKFA D	81	2.2 TDCi 04.2006 → 08.2014	QVFA D	107
2.0 EcoBlue 05.2019 →	BKFB D	81	2.2 TDCi 04.2006 → 08.2014	QWFA D	107
2.0 EcoBlue 05.2019 →	BLFA D	81	2.2 TDCi 10.2007 → 08.2014	PGFA D	107
2.0 EcoBlue 05.2019 →	BLFB D	81	2.2 TDCi 10.2007 → 08.2014	PGFB D	107
2.0 EcoBlue 05.2019 →	YMFA D	81	2.2 TDCi 10.2007 → 08.2014	UHFA D	108
2.0 EcoBlue 05.2019 →	YMF6 D	81	2.2 TDCi 10.2007 → 08.2014	UHFB D	108
2.0 EcoBlue 05.2019 →	YNFA D	81	2.2 TDCi 10.2007 → 08.2014	UHFC D	109
2.0 EcoBlue 05.2019 →	YNFB D	81	2.2 TDCi 10.2008 → 08.2014	SRFA D	107
2.2 TDCi 04.2012 → 12.2015	CVFF D	107	2.2 TDCi 10.2008 → 08.2014	SRFB D	107
2.2 TDCi 04.2012 → 12.2015	CYF4 D	109	2.2 TDCi 10.2008 → 08.2014	SRFC D	107
2.2 TDCi 04.2012 → 12.2015	CYFF D	107	2.2 TDCi 10.2008 → 08.2014	SRFD D	107
2.2 TDCi 04.2012 → 12.2015	DRF4 D	109	2.2 TDCi 10.2008 → 08.2014	SRFE D	107
2.2 TDCi 04.2012 → 12.2015	DRFF D	107	2.2 TDCi 10.2011 → 08.2014	CYFA D	107
2.2 TDCi 04.2012 → 12.2015	DRFG D	107	2.2 TDCi 10.2011 → 08.2014	CYFB D	107
<b>TRANSIT Bus (E_)</b>			2.2 TDCi 10.2011 → 08.2014	CYFC D	107
2.0 09.1991 → 09.1994	NBA B	132	2.2 TDCi 10.2011 → 08.2014	CYFD D	109
2.0 (EBL, EBS, ECL, EDS, EDL, EGL, ESS, ESL, EUS)	NSF B	101	2.2 TDCi 10.2011 → 08.2014	DRFA D	107
2.0 (EBL, EBS, ECL, EDS, EDL, EGL, ESS, ESL, EUS)	NSG B	101	2.2 TDCi 10.2011 → 08.2014	DRFB D	107
2.0 (EBL, EBS, ECL, EDS, EDL, EGL, ESS, ESL, EUS)	NSH BG	99	2.2 TDCi 10.2011 → 08.2014	DRFC D	107
2.0 CNG 06.1994 → 03.2000	NSH BG	99	2.2 TDCi 10.2011 → 08.2014	DRFD D	109
2.0 i (EBL, EDL, EGL, ESS, EUS)	NCA B	133	2.2 TDCi 10.2011 → 08.2014	DRFE D	109
2.5 DI (EBL, ECL, EDS, EDL)	4HB D	140	2.2 TDCi RWD 09.2011 → 08.2014	USRA D	111
2.5 DI (EBL, ECL, EDS, EDL)	4HC D	142	2.2 TDCi RWD 09.2011 → 08.2014	USRB D	111
2.5 DI (EBL, EDL, EDS, ESL, ESS)	4ED D	140	2.2 TDCi RWD 10.2011 → 08.2014	CYRA D	111
2.5 DI (EBL, EDS, ESL, ESS, EUS)	4FB D	142	2.2 TDCi RWD 10.2011 → 08.2014	DRRA D	111
2.5 DI (EBL, EDS, ESL, ESS, EUS)	4FC D	142	2.2 TDCi RWD 10.2011 → 08.2014	DRRB D	111
2.5 DI (EBL, EDS, ESL, ESS, EUS)	4FD D	142	2.4 DI (F_B_, F_C_, F_A_) 01.2000 → 05.2006	DRRC D	109
2.5 DI (EBS, EDS, EGL, ESS, EUS)	4DA D	140	2.4 DI (F_B_, F_C_, F_A_) 01.2000 → 05.2006	D2FA D	121
2.5 TD (EBL, EDL, EDS, EGL, ESL, ESS, EUS)	4GA D	140	2.4 DI RWD (F_B_, F_C_) 01.2000 → 05.2006	D2FB D	121
2.5 TD (EBL, EDL, EDS, EGL, ESL, ESS, EUS)	4GB D	140	2.4 DI RWD (F_B_, F_C_) 01.2000 → 05.2006	F4FA D	123
2.5 TD (EBL, EDL, EDS, EGL, ESL, ESS, EUS)	4GC D	140	2.4 DI RWD (F_B_, F_C_) 01.2000 → 05.2006	D4FA D	121
2.5 TD (EBL, EDL, EDS, EGL, ESL, ESS, EUS)	4GD D	140	2.4 TDCi 03.2004 → 05.2006	H9FA D	124
2.5 TD (EBL, EDL, EDS, EGL, ESL, ESS, EUS)	4GE D	142	2.4 TDCi 04.2006 → 08.2014	H9FD D	126
2.5 TD (EBL, EDL, EDS, EGL, ESL, ESS, EUS)	4GF D	141	2.4 TDCi 04.2006 → 08.2014	JXFA D	127
2.5 TD (EBS, EBL, ECL, EDS, EDL, ESS, EUS)	4GA D	140	2.4 TDCi 04.2006 → 08.2014	JXFC D	127
2.5 TD (EB_, ED_, ES_) 08.1994 → 06.2000	4HA D	140	2.4 TDCi 04.2006 → 08.2014	PHFA D	127
2.5 TD (ECL, EDL, EDS, ESL, ESS, EUS)	4EB D	142	2.4 TDCi 04.2006 → 08.2014	PHFC D	127
			2.4 TDCi 4x4 11.2006 → 08.2014	H9FB D	125
			2.4 TDE 03.2004 → 05.2006	FXFA D	121
			2.4 TDE (F_C_, F_B_, F_A_) 07.2001 → 05.2006	DOFA D	121
			3.2 TDCi 02.2008 → 08.2014	SAFA D	128
			3.2 TDCi 02.2008 → 08.2014	SAFB D	128
			<b>TRANSIT Bus (T_)</b>		
			2.0 (TBS, TCL, TCS, TEL, TES) 11.1985 → 09.1992	NAT B	132
			2.0 (TBS, TCL, TCS, TEL, TES) 11.1985 → 09.1992	NAV B	134
			2.0 Cat (TBS, TCL, TCS) 12.1985 → 09.1992	N6T B	132
			2.5 D (TBS, TEL, TES) 09.1988 → 09.1992	4BA D	140
			<b>TRANSIT Bus (V_)</b>		
			1.6 (VAS, VLS, VZS) 12.1977 → 04.1981	4RB B	118
			2.0 (VAS, VBLVIL, VLS, VUL, VZS) 12.1977 → 07.1982	4RC B	134

			Pos				Pos		
2.0 (VAS, VIL, VLS, VUL, VZS)	12.1977 → 10.1986	4RC	B	134	2.0 EcoBlue	05.2019 →	BLFB	D	81
2.0 (VAS, VLS, VZS)	12.1977 → 10.1986	4RC	B	134	2.0 EcoBlue	05.2019 →	YMFA	D	81
<b>TRANSIT CONNECT (P65, P70, P80)</b>					2.0 EcoBlue	05.2019 →	YMFB	D	81
1.8 16V	06.2002 → 12.2013	EYPA	B	59	2.0 EcoBlue	05.2019 →	YNFA	D	81
1.8 16V LPG	06.2002 → 12.2013	EYPA	B	59	2.0 EcoBlue	05.2019 →	YNFB	D	81
1.8 Di	06.2002 → 12.2013	BHPA	D	73	2.2 TDCi	04.2012 → 12.2015	CVFF	D	107
1.8 Di	06.2002 → 12.2013	P7PA	D	73	2.2 TDCi	04.2012 → 12.2015	CYF4	D	109
1.8 Di	06.2002 → 12.2013	P7PB	D	74	2.2 TDCi	04.2012 → 12.2015	CYFF	D	107
1.8 Di	06.2002 → 12.2013	R2PA	D	73	2.2 TDCi	04.2012 → 12.2015	DRF4	D	109
1.8 TDCi	06.2002 → 12.2013	HCPA	D	73	2.2 TDCi	04.2012 → 12.2015	DRFF	D	107
1.8 TDCi	06.2002 → 12.2013	HCPB	D	73	2.2 TDCi	04.2012 → 12.2015	DRFG	D	107
1.8 TDCi	06.2002 → 12.2013	R3PA	D	74	<b>TRANSIT CUSTOM V362 Van (FY, FZ)</b>				
1.8 TDCi	06.2002 → 12.2013	RWPE	D	74	2.0 EcoBlue	12.2015 →	YLF6	D	81
1.8 TDCi	06.2002 → 12.2013	RWPF	D	74	2.0 EcoBlue	12.2015 →	YLFS	D	81
1.8 TDCi	08.2006 → 12.2013	RWPA	D	73	2.0 EcoBlue	12.2015 →	YMF6	D	81
1.8 TDCi	08.2006 → 12.2013	RWPC	D	74	2.0 EcoBlue	12.2015 →	YMFS	D	81
1.8 TDCi	08.2006 → 12.2013	RWPD	D	74	2.0 EcoBlue	12.2015 →	YNF6	D	81
<b>TRANSIT CONNECT II</b>					2.0 EcoBlue	12.2015 →	YNFS	D	81
1.5 TDCi	01.2014 →	UGCA	D	12	2.0 EcoBlue	05.2019 →	BJFA	D	81
1.5 TDCi	01.2014 →	UGCB	D	11	2.0 EcoBlue	05.2019 →	BJFB	D	81
1.5 TDCi	01.2014 →	XUCC	D	11	2.0 EcoBlue	05.2019 →	BKFA	D	81
1.5 TDCi	01.2014 →	XUCD	D	11	2.0 EcoBlue	05.2019 →	BKFB	D	81
1.6 TDCi	01.2014 →	T3CA	D	25	2.0 EcoBlue	05.2019 →	BLFA	D	81
1.6 TDCi	01.2014 →	T3CB	D	26	2.0 EcoBlue	05.2019 →	BLFB	D	81
1.6 TDCi	01.2014 →	T3CC	D	26	2.0 EcoBlue	05.2019 →	YMFA	D	81
<b>TRANSIT CONNECT V408 Box Body/MPV</b>					2.0 EcoBlue	05.2019 →	YMFB	D	81
1.0 EcoBoost	02.2013 →	M2GA	B	8	2.0 EcoBlue	05.2019 →	YNFA	D	81
1.0 EcoBoost	08.2015 →	M2GB	B	8	2.0 EcoBlue	05.2019 →	YNFB	D	81
1.0 EcoBoost	05.2018 →	B3GA	B	10	2.2 TDCi	04.2012 → 12.2015	CVFF	D	107
1.5 TDCi	05.2015 →	XVGA	D	11	2.2 TDCi	04.2012 → 12.2015	CYF4	D	109
1.5 TDCi	05.2015 →	XVGB	D	11	2.2 TDCi	04.2012 → 12.2015	CYFF	D	107
1.5 TDCi	05.2015 →	XVGC	D	11	2.2 TDCi	04.2012 → 12.2015	DRF4	D	109
1.5 TDCi	05.2015 →	XWGA	D	11	2.2 TDCi	04.2012 → 12.2015	DRFF	D	107
1.5 TDCi	05.2015 →	XWGB	D	11	2.2 TDCi	04.2012 → 12.2015	DRFG	D	107
1.5 TDCi	05.2015 →	XWGC	D	11	<b>TRANSIT Platform/Chassis (E_)</b>				
1.5 TDCi	05.2015 →	XXGA	D	11	2.0	04.1991 → 07.1994	NBA	B	132
<b>TRANSIT COURIER B460 Box Body/MPV</b>					2.0 (EME/L/S, ENE/L/S)	09.1991 → 08.1994	NCA	B	133
1.0 EcoBoost	02.2014 →	SFCA	B	8	2.0 (EME/L/S, ENE/L/S)	08.1994 → 03.2000	NSF	B	101
1.0 EcoBoost	02.2014 →	SFCB	B	8	2.0 (EME/L/S, ENE/L/S)	08.1994 → 03.2000	NSG	B	101
1.0 EcoBoost	02.2014 →	SFCC	B	8	2.5 DI (EME/L/S, ENE/L/S)	09.1991 → 08.1994	4DA	D	140
1.0 EcoBoost	02.2014 →	SFCD	B	8	2.5 DI (EME/L/S, ENE/L/S)	08.1994 → 03.2000	4HB	D	140
1.5 EcoBlue	04.2018 →	XXCA	D	11	2.5 DI (EME/L/S, ENE/L/S)	08.1994 → 03.2000	4HC	D	142
1.5 EcoBlue	04.2018 →	XXCB	D	11	2.5 DI (EML, ENE/L)	05.1999 → 03.2000	4ED	D	140
1.5 EcoBlue	04.2018 →	XXCC	D	11	2.5 DI (EML/S, ENL/S)	08.1994 → 03.2000	4FB	D	142
1.5 TDCi	02.2014 →	UGCA	D	12	2.5 DI (EML/S, ENL/S)	08.1994 → 03.2000	4FC	D	142
1.5 TDCi	02.2014 →	UGCB	D	11	2.5 DI (EML/S, ENL/S)	08.1994 → 03.2000	4FD	D	142
1.5 TDCi	02.2014 →	XUCC	D	11	2.5 DI (EML/S, ENL/S)	08.1994 → 03.2000	4HA	D	140
1.5 TDCi	02.2014 →	XUCD	D	11	2.5 TD	08.1994 → 03.2000	4HA	D	140
1.5 TDCi	05.2015 →	XVCA	D	11	2.5 TD (EME/L/S, ENE/L)	09.1991 → 08.1994	4EA	D	140
1.5 TDCi	05.2015 →	XVCB	D	11	2.5 TD (EME/L/S, ENE/L)	11.1992 → 08.1994	4GA	D	140
1.5 TDCi	05.2015 →	XVCC	D	11	2.5 TD (EME/L/S, ENE/L)	08.1994 → 03.2000	4EB	D	142
1.5 TDCi	04.2018 →	XWCA	D	11	2.5 TD (EME/L/S, ENE/L)	08.1994 → 03.2000	4EC	D	142
1.5 TDCi	04.2018 →	XWCB	D	11	2.5 TD (EME/L/S, ENE/L)	08.1994 → 03.2000	4GA	D	140
1.6 TDCi	02.2014 →	T3CA	D	25	2.5 TD (EME/L/S, ENE/L)	08.1994 → 03.2000	4GB	D	140
1.6 TDCi	02.2014 →	T3CB	D	26	2.5 TD (EME/L/S, ENE/L)	08.1994 → 03.2000	4GC	D	140
1.6 TDCi	02.2014 →	T3CC	D	26	2.5 TD (EME/L/S, ENE/L)	08.1994 → 03.2000	4GD	D	140
<b>TRANSIT CUSTOM V362 Bus (F3)</b>					2.5 TD (EME/L/S, ENE/L)	08.1994 → 03.2000	4GE	D	142
2.0 EcoBlue	12.2015 →	YLF6	D	81	2.5 TD (EME/L/S, ENE/L)	08.1994 → 03.2000	4GF	D	141
2.0 EcoBlue	12.2015 →	YLFS	D	81	<b>TRANSIT Platform/Chassis (FM, FN)</b>				
2.0 EcoBlue	12.2015 →	YMF6	D	81					
2.0 EcoBlue	12.2015 →	YMFS	D	81					
2.0 EcoBlue	12.2015 →	YNF6	D	81					
2.0 EcoBlue	12.2015 →	YNFS	D	81					
2.0 EcoBlue	05.2019 →	BJFA	D	81					
2.0 EcoBlue	05.2019 →	BJFB	D	81					
2.0 EcoBlue	05.2019 →	BKFA	D	81					
2.0 EcoBlue	05.2019 →	BKFB	D	81					
2.0 EcoBlue	05.2019 →	BLFA	D	81					

F

		Pos			Pos
2.0 DI (F_E_, F_F_) 08.2000 → 05.2006	ABFA D	104	<b>TRANSIT TOURNEO Bus</b>		
2.0 DI (F_E_, F_F_) 08.2000 → 05.2006	D3FA D	104	2.0 11.1994 → 12.2000	NSF B	101
2.0 DI (F_E_, F_F_) 08.2000 → 05.2006	F3FA D	104	2.0 11.1994 → 12.2000	NSG B	101
2.0 TDCi (F_E_, F_F_) 08.2002 → 05.2006	FIFA D	104	2.0 11.1994 → 12.2000	NSH BG	99
2.4 DI (F_A_, F_B_, F_C_, F_D_) 01.2000 → 05.2006	D2FA D	121	2.2 10.2011 → 08.2014	CYFA D	107
2.4 DI (F_A_, F_B_, F_C_, F_D_) 01.2000 → 05.2006	D2FB D	121	2.2 10.2011 → 08.2014	CYFB D	107
2.4 DI (F_A_, F_B_, F_C_, F_D_) 01.2000 → 05.2006	D2FE D	122	2.2 10.2011 → 08.2014	CYFC D	107
2.4 DI (F_A_, F_B_, F_C_, F_D_) 01.2000 → 05.2006	D2FE D	122	2.2 10.2011 → 08.2014	CYFD D	109
2.4 DI (F_A_, F_B_, F_C_, F_D_) 01.2000 → 05.2006	D4FA D	121	2.2 TDCi 07.2006 → 08.2014	QVFA D	107
2.4 DI (F_A_, F_B_, F_C_, F_D_) 01.2000 → 05.2006	D4FA D	121	2.2 TDCi 07.2006 → 08.2014	QWFA D	107
2.4 DI (F_A_, F_B_, F_C_, F_D_) 01.2000 → 05.2006	F4FA D	123	2.2 TDCi 10.2007 → 08.2014	PGFA D	107
2.4 DI (F_A_, F_B_, F_C_, F_D_) 01.2000 → 05.2006	F4FA D	123	2.2 TDCi 10.2007 → 08.2014	PGFB D	107
2.4 TDCi 03.2004 → 05.2006	H9FA D	124	2.2 TDCi 10.2007 → 08.2014	UHFA D	108
2.4 TDE 07.2001 → 05.2006	DOFA D	121	2.2 TDCi 10.2007 → 08.2014	UHFB D	108
2.4 TDE 03.2004 → 05.2006	FXFA D	121	2.2 TDCi 10.2007 → 08.2014	UHFC D	109
<b>TRANSIT Platform/Chassis (FM_, FN_, FF_)</b>			2.2 TDCi 10.2008 → 08.2014	SRFA D	107
2.2 TDCi 04.2006 → 08.2014	P8FA D	107	2.2 TDCi 10.2008 → 08.2014	SRFB D	107
2.2 TDCi 04.2006 → 08.2014	P8FB D	107	2.2 TDCi 10.2008 → 08.2014	SRFC D	107
2.2 TDCi 04.2006 → 08.2014	QVFA D	107	2.2 TDCi 10.2008 → 08.2014	SRFD D	107
2.2 TDCi 04.2006 → 08.2014	QWFA D	107	2.2 TDCi 10.2008 → 08.2014	SRFE D	107
2.2 TDCi 10.2007 → 09.2011	PGFA D	107	2.4 D 08.1994 → 06.2000	4HA D	140
2.2 TDCi 10.2007 → 09.2011	PGFB D	107	2.5 DI 11.1994 → 12.2000	4FB D	142
2.2 TDCi 10.2007 → 09.2011	UHFA D	108	2.5 DI 11.1994 → 12.2000	4FC D	142
2.2 TDCi 10.2007 → 09.2011	UHFB D	108	2.5 DI 11.1994 → 12.2000	4FD D	142
2.2 TDCi 10.2007 → 09.2011	UHFC D	109	2.5 DI 11.1994 → 12.2000	4HB D	140
2.2 TDCi 10.2008 → 08.2014	SRFA D	107	2.5 DI 11.1994 → 12.2000	4HC D	142
2.2 TDCi 10.2008 → 08.2014	SRFB D	107	2.5 TD 11.1994 → 12.2000	4GA D	140
2.2 TDCi 10.2008 → 08.2014	SRFC D	107	2.5 TD 11.1994 → 12.2000	4GB D	140
2.2 TDCi 10.2008 → 08.2014	SRFD D	107	2.5 TD 11.1994 → 12.2000	4GC D	140
2.2 TDCi 10.2008 → 08.2014	SRFE D	107	2.5 TD 11.1994 → 12.2000	4GD D	140
2.2 TDCi 10.2011 → 08.2014	CYFA D	107	2.5 TD 04.1998 → 12.2000	4EB D	142
2.2 TDCi 10.2011 → 08.2014	CYFB D	107	2.5 TD 04.1998 → 12.2000	4EC D	142
2.2 TDCi 10.2011 → 08.2014	CYFC D	107	<b>TRANSIT TOURNEO Bus (FC_)</b>		
2.2 TDCi 10.2011 → 08.2014	CYFD D	109	2.0 06.2000 → 08.2003	D3FA D	104
2.2 TDCi 10.2011 → 08.2014	DRFA D	107	2.0 06.2000 → 03.2005	ABFA D	104
2.2 TDCi 10.2011 → 08.2014	DRFB D	107	2.0 03.2002 → 03.2006	FIFA D	104
2.2 TDCi 10.2011 → 08.2014	DRFC D	107	<b>TRANSIT V363 Bus (FAD, FBD)</b>		
2.2 TDCi 10.2011 → 08.2014	DRFD D	109	2.0 EcoBlue 03.2016 →	YLF6 D	81
2.2 TDCi 10.2011 → 08.2014	DRFE D	109	2.0 EcoBlue 03.2016 →	YLFS D	81
2.2 TDCi 4x4 10.2011 → 08.2014	CYRB D	111	2.0 EcoBlue 03.2016 →	YMF6 D	81
2.2 TDCi 4x4 10.2011 → 08.2014	CYRC D	109	2.0 EcoBlue 03.2016 →	YMFS D	81
2.2 TDCi RWD 10.2011 → 08.2014	CVRA D	111	2.0 EcoBlue 03.2016 →	YNF6 D	81
2.2 TDCi RWD 10.2011 → 08.2014	CVRB D	111	2.0 EcoBlue 03.2016 →	YNFS D	81
2.2 TDCi RWD 10.2011 → 08.2014	CVRC D	109	2.0 EcoBlue 12.2018 →	YMFA D	81
2.2 TDCi RWD 10.2011 → 08.2014	CYRA D	111	2.0 EcoBlue 12.2018 →	YNFA D	81
2.2 TDCi RWD 10.2011 → 08.2014	DRRA D	111	2.0 EcoBlue 05.2019 →	BJFA D	81
2.2 TDCi RWD 10.2011 → 08.2014	DRRB D	111	2.0 EcoBlue 05.2019 →	BJFB D	81
2.2 TDCi RWD 10.2011 → 08.2014	DRRC D	109	2.0 EcoBlue 05.2019 →	BKFA D	81
2.4 TDCi 4x4 11.2006 → 08.2014	H9FB D	125	2.0 EcoBlue 05.2019 →	BKFB D	81
2.4 TDCi RWD 04.2006 → 08.2014	H9FB D	125	2.0 EcoBlue 05.2019 →	BLFA D	81
2.4 TDCi RWD 04.2006 → 08.2014	H9FD D	126	2.0 EcoBlue 05.2019 →	BLFB D	81
2.4 TDCi RWD 04.2006 → 08.2014	JXFA D	127	2.0 EcoBlue 05.2019 →	YMF6 D	81
2.4 TDCi RWD 04.2006 → 08.2014	JXFC D	127	2.0 EcoBlue 05.2019 →	YNFB D	81
2.4 TDCi RWD 04.2006 → 08.2014	PHFA D	127	2.2 TDCi 08.2013 → 12.2018	CY14 D	109
2.4 TDCi RWD 04.2006 → 08.2014	PHFC D	127	2.2 TDCi 08.2013 → 12.2018	CYF5 D	107
3.2 TDCi RWD 09.2007 → 08.2014	SAFA D	128	2.2 TDCi 08.2013 → 12.2018	CYFG D	107
3.2 TDCi RWD 09.2007 → 08.2014	SAFB D	128	2.2 TDCi 08.2013 → 12.2018	DRF5 D	107
<b>TRANSIT Platform/Chassis (T_)</b>			2.2 TDCi 08.2013 → 12.2018	DRFF D	107
2.0 (TTE, TTL, TTS) 01.1986 → 09.1992	NAT B	132	2.2 TDCi 08.2013 → 12.2018	DRFG D	107
2.0 (TTE, TTL, TTS) 01.1986 → 09.1992	NAV B	134	2.2 TDCi 08.2013 → 12.2018	USF6 D	109
2.0 Cat (TUL) 11.1985 → 09.1992	N6T B	132	2.2 TDCi 12.2014 → 12.2018	CVF5 D	107
2.5 DI (TTE, TTL, TTS, TUL) 09.1988 → 09.1992	4BA D	140	2.2 TDCi 4x4 08.2013 → 12.2018	CY24 D	109
<b>TRANSIT Platform/Chassis (V_)</b>			2.2 TDCi 4x4 08.2013 → 12.2018	CYR5 D	112
1.6 (VCS, VDS) 11.1977 → 10.1986	B B	118	2.2 TDCi All-wheel Drive 08.2015 → 12.2018	CV24 D	109
2.0 (VGL, VSL, VTL) 12.1977 → 07.1982	4RC B	134	2.2 TDCi All-wheel Drive 08.2015 → 12.2018	CVR5 D	111
2.0 (VGL, VSL, VTL, VCS, VDS) 12.1977 → 10.1986	4RC B	134	2.2 TDCi RWD 08.2013 → 12.2018	CV24 D	109
			2.2 TDCi RWD 08.2013 → 12.2018	CVR5 D	111
			2.2 TDCi RWD 08.2013 → 12.2018	CYR5 D	112
			2.2 TDCi RWD 08.2013 → 12.2018	DRR5 D	111

					Pos						Pos
2.2 TDCi RWD	08.2013 → 12.2018	UHR5	D	111	2.2 TDCi RWD	08.2013 → 12.2018	CVR5	D	111		
2.2 TDCi RWD	08.2013 → 12.2018	USR6	D	111	2.2 TDCi RWD	08.2013 → 12.2018	CYR5	D	112		
2.2 TDCi RWD	08.2013 → 12.2018	UYR6	D	111	2.2 TDCi RWD	08.2013 → 12.2018	DRR5	D	111		
<b>TRANSIT V363 Platform/Chassis (FED, FFD)</b>											
2.0 EcoBlue	03.2016 →	YLF6	D	81	2.2 TDCi RWD	08.2013 → 12.2018	UYR6	D	111		
2.0 EcoBlue	03.2016 →	YLFS	D	81	<b>TRANSIT Van (E_ )</b>						
2.0 EcoBlue	03.2016 →	YMF6	D	81	2.0	09.1991 → 06.1994	NBA	B	132		
2.0 EcoBlue	03.2016 →	YMFS	D	81	2.0 (EAL, EAS)	06.1994 → 03.2000	NSF	B	101		
2.0 EcoBlue	03.2016 →	YNF6	D	81	2.0 (EAL, EAS)	06.1994 → 03.2000	NSG	B	101		
2.0 EcoBlue	03.2016 →	YNFS	D	81	2.0 (EAL, EAS)	06.1994 → 03.2000	NSH	BG	99		
2.0 EcoBlue	12.2018 →	YMFA	D	81	2.0 i (EAL, EAS)	09.1991 → 06.1994	NCA	B	133		
2.0 EcoBlue	12.2018 →	YNFA	D	81	2.5 DI (EAL, EAS)	10.1992 → 06.1994	4GA	D	140		
2.0 EcoBlue	05.2019 →	BJFA	D	81	2.5 DI (EAL, EAS)	06.1994 → 03.2000	4FB	D	142		
2.0 EcoBlue	05.2019 →	BJFB	D	81	2.5 DI (EAL, EAS)	06.1994 → 03.2000	4FC	D	142		
2.0 EcoBlue	05.2019 →	BKFA	D	81	2.5 DI (EAL, EAS)	06.1994 → 03.2000	4FD	D	142		
2.0 EcoBlue	05.2019 →	BKFB	D	81	2.5 DI (EAL, EAS)	06.1994 → 03.2000	4HB	D	140		
2.0 EcoBlue	05.2019 →	BLFA	D	81	2.5 DI (EAL, EAS)	06.1994 → 03.2000	4HC	D	142		
2.0 EcoBlue	05.2019 →	BLFB	D	81	2.5 DI (EAL, EAS)	05.1999 → 03.2000	4ED	D	140		
2.0 EcoBlue	05.2019 →	YMFB	D	81	2.5 DI (EAS, EAL)	05.1991 → 06.1994	4DA	D	140		
2.0 EcoBlue	05.2019 →	YNFB	D	81	2.5 TD (EAL, EAS)	06.1994 → 03.2000	4GA	D	140		
2.2 TDCi	08.2013 → 12.2018	CVF5	D	107	2.5 TD (EAL, EAS)	06.1994 → 03.2000	4GB	D	140		
2.2 TDCi	08.2013 → 12.2018	CY14	D	109	2.5 TD (EAL, EAS)	06.1994 → 03.2000	4GC	D	140		
2.2 TDCi	08.2013 → 12.2018	CYF5	D	107	2.5 TD (EAL, EAS)	06.1994 → 03.2000	4GD	D	140		
2.2 TDCi	08.2013 → 12.2018	CYFG	D	107	2.5 TD (EAL, EAS)	06.1994 → 03.2000	4GE	D	142		
2.2 TDCi	08.2013 → 12.2018	DRF5	D	107	2.5 TD (EAL, EAS)	06.1994 → 03.2000	4GF	D	141		
2.2 TDCi	08.2013 → 12.2018	DRFF	D	107	2.5 TD (EAS)	10.1998 → 03.2000	4HA	D	140		
2.2 TDCi	08.2013 → 12.2018	DRFG	D	107	2.5 TD (EAS, EAL)	05.1991 → 06.1994	4EA	D	140		
2.2 TDCi	08.2013 → 12.2018	USF6	D	109	2.5 TDI (EAL, EAS)	06.1994 → 03.2000	4EB	D	142		
2.2 TDCi 4x4	08.2013 → 12.2018	CV24	D	109	2.5 TDI (EAL, EAS)	06.1994 → 03.2000	4EC	D	142		
2.2 TDCi 4x4	08.2013 → 12.2018	CVR5	D	111	<b>TRANSIT Van (FA_ )</b>						
2.2 TDCi 4x4	08.2013 → 12.2018	CY24	D	109	2.0 DI (FAE_ , FAF_ , FAG_ )	08.2000 → 05.2006	ABFA	D	104		
2.2 TDCi 4x4	08.2013 → 12.2018	CYR5	D	112	2.0 DI (FAE_ , FAF_ , FAG_ )	08.2000 → 05.2006	D3FA	D	104		
2.2 TDCi RWD	08.2013 → 12.2018	CV24	D	109	2.0 DI (FAE_ , FAF_ , FAG_ )	08.2000 → 05.2006	F3FA	D	104		
2.2 TDCi RWD	08.2013 → 12.2018	CVR5	D	111	2.0 TDCi	08.2002 → 05.2006	FIFA	D	104		
2.2 TDCi RWD	08.2013 → 12.2018	DRR5	D	111	2.2 TDCi	04.2006 → 08.2014	P8FA	D	107		
2.2 TDCi RWD	08.2013 → 12.2018	UHR5	D	111	2.2 TDCi	04.2006 → 08.2014	P8FB	D	107		
2.2 TDCi RWD	08.2013 → 12.2018	USR6	D	111	2.2 TDCi	04.2006 → 08.2014	QVFA	D	107		
2.2 TDCi RWD	08.2013 → 12.2018	UYR6	D	111	2.2 TDCi	04.2006 → 08.2014	QWFA	D	107		
<b>TRANSIT V363 Van (FCD, FDD)</b>											
2.0 EcoBlue	03.2016 →	YLF6	D	81	2.2 TDCi	10.2007 → 08.2014	PGFA	D	107		
2.0 EcoBlue	03.2016 →	YLFS	D	81	2.2 TDCi	10.2007 → 08.2014	PGFB	D	107		
2.0 EcoBlue	03.2016 →	YMF6	D	81	2.2 TDCi	10.2007 → 08.2014	UHFA	D	108		
2.0 EcoBlue	03.2016 →	YMFS	D	81	2.2 TDCi	10.2007 → 08.2014	UHFB	D	108		
2.0 EcoBlue	03.2016 →	YNF6	D	81	2.2 TDCi	10.2007 → 08.2014	UHFC	D	109		
2.0 EcoBlue	03.2016 →	YNFS	D	81	2.2 TDCi	10.2008 → 08.2014	SRFA	D	107		
2.0 EcoBlue	12.2018 →	YMFA	D	81	2.2 TDCi	10.2008 → 08.2014	SRFB	D	107		
2.0 EcoBlue	12.2018 →	YNFA	D	81	2.2 TDCi	10.2008 → 08.2014	SRFC	D	107		
2.0 EcoBlue	05.2019 →	BJFA	D	81	2.2 TDCi	10.2008 → 08.2014	SRFD	D	107		
2.0 EcoBlue	05.2019 →	BJFB	D	81	2.2 TDCi	10.2008 → 08.2014	SRFE	D	107		
2.0 EcoBlue	05.2019 →	BKFA	D	81	2.2 TDCi	10.2011 → 08.2014	CYFA	D	107		
2.0 EcoBlue	05.2019 →	BKFB	D	81	2.2 TDCi	10.2011 → 08.2014	CYFB	D	107		
2.0 EcoBlue	05.2019 →	BLFA	D	81	2.2 TDCi	10.2011 → 08.2014	CYFC	D	107		
2.0 EcoBlue	05.2019 →	BLFB	D	81	2.2 TDCi	10.2011 → 08.2014	CYFD	D	109		
2.0 EcoBlue	05.2019 →	YMFB	D	81	2.2 TDCi	10.2011 → 08.2014	DRFA	D	107		
2.0 EcoBlue	05.2019 →	YNFB	D	81	2.2 TDCi	10.2011 → 08.2014	DRFB	D	107		
2.2 TDCi	08.2013 → 12.2018	CVF5	D	107	2.2 TDCi	10.2011 → 08.2014	DRFC	D	107		
2.2 TDCi	08.2013 → 12.2018	CY14	D	109	2.2 TDCi	10.2011 → 08.2014	DRFD	D	109		
2.2 TDCi	08.2013 → 12.2018	CYF5	D	107	2.2 TDCi	10.2011 → 08.2014	DRFE	D	109		
2.2 TDCi	08.2013 → 12.2018	CYFG	D	107	2.2 TDCi 4x4	10.2011 → 08.2014	CYRB	D	111		
2.2 TDCi	08.2013 → 12.2018	DRF5	D	107	2.2 TDCi 4x4	10.2011 → 08.2014	CYRC	D	109		
2.2 TDCi	08.2013 → 12.2018	DRFF	D	107	2.2 TDCi RWD	09.2011 → 12.2014	CYRA	D	111		
2.2 TDCi	08.2013 → 12.2018	DRFG	D	107	2.2 TDCi RWD	10.2011 → 08.2014	CVRA	D	111		
2.2 TDCi	08.2013 → 12.2018	USF6	D	109	2.2 TDCi RWD	10.2011 → 08.2014	CVRB	D	111		
2.2 TDCi 4x4	08.2013 → 12.2018	CY24	D	109	2.2 TDCi RWD	10.2011 → 08.2014	CVRC	D	109		
2.2 TDCi 4x4	08.2013 → 12.2018	CYR5	D	112	2.2 TDCi RWD	10.2011 → 08.2014	DRRA	D	111		
2.2 TDCi 4x4	08.2015 → 12.2018	CV24	D	109	2.2 TDCi RWD	10.2011 → 08.2014	DRRB	D	111		
2.2 TDCi 4x4	08.2015 → 12.2018	CVR5	D	111	2.2 TDCi RWD	10.2011 → 08.2014	DRRC	D	109		
2.2 TDCi RWD	08.2013 → 12.2018	CV24	D	109							

F



		Pos			Pos						
2.2 TDCi RWD	10.2011 → 08.2014	USRA	D	111	2429	01.2012 →	ISB 6.7L	D	153		
2.2 TDCi RWD	10.2011 → 08.2014	USRB	D	111	2623	09.2012 →	ISB 6.7L	D	153		
2.4 DI (FAA_, FAB_, FAC_, FAD_)	01.2000 → 05.2006	D2FA	D	121	2629	09.2012 →	ISB 6.7L	D	153		
2.4 DI (FAA_, FAB_, FAC_, FAD_)	01.2000 → 05.2006	D2FB	D	121	2632 E	06.2007 →	ISC 8.3L	D	158		
2.4 DI RWD (FAA_, FAB_, FAC_, FAD_)	01.2000 → 05.2006	D4FA	D	121	2817	04.1982 →	F 6L 413 F	D	160		
2.4 DI RWD (FAA_, FAB_, FAC_, FAD_)	01.2000 → 05.2006	D4FA	D	121	2820	12.1984 → 08.1987	F 6 L 413 FZ	D	159		
2.4 DI RWD (FAA_, FAB_, FAC_, FAD_)	01.2000 → 05.2006	F4FA	D	123	2842 T	09.2012 →	F3AE3681D	D	161		
2.4 TD	08.2000 → 08.2003	F4FA	D	123	3020	04.1982 → 12.1999	F 6 L 413 FZ	D	159		
2.4 TDCi	03.2004 → 05.2006	H9FA	D	124	3220	04.1982 → 12.1999	F 6 L 413 FZ	D	159		
2.4 TDCi 4x4	11.2006 → 08.2014	H9FB	D	125	915	01.1982 → 1981	360 DT	D	149		
2.4 TDCi RWD	04.2006 → 08.2014	H9FB	D	125	C 1215	04.1992 →	6 BTAA	D	147		
2.4 TDCi RWD	04.2006 → 08.2014	H9FD	D	126	C 1415	04.1992 →	6 BTAA	D	147		
2.4 TDCi RWD	04.2006 → 08.2014	JXFA	D	127	C 1421	12.1999 →	6 BTAA	D	147		
2.4 TDCi RWD	04.2006 → 08.2014	JXFC	D	127	C 1621	12.1999 →	6 BTAA	D	147		
2.4 TDCi RWD	04.2006 → 08.2014	PHFA	D	127	C 1630	01.1993 →	6 CTAA 8.3	D	157		
2.4 TDCi RWD	04.2006 → 08.2014	PHFC	D	127	C 1717	01.2003 →	6 BTAA	D	147		
2.4 TDE	07.2001 → 05.2006	DOFA	D	121	C 1831	03.2002 → 06.2007	6 CTAA 8.3	D	157		
2.4 TDE	03.2004 → 05.2006	FXFA	D	121	C 2042 T	09.2012 →	F3AE3681D	D	161		
3.2 TDCi RWD	09.2007 → 08.2014	SAFA	D	128	C 2422 E	01.2006 → 04.2011	6 BTAA	D	147		
3.2 TDCi RWD	09.2007 → 08.2014	SAFB	D	128	C 2630	06.1997 → 12.2002	6 CTAA 8.3	D	157		
<b>TRANSIT Van (T_)</b>						C 3530 T	11.1991 → 12.1996	6 CTAA 8.3	D	157	
2.0 (TAL, TAS, TGL, TWS)	09.1985 → 09.1992	NAT	B	132	C 4030 T	07.1995 → 12.2002	6 CTAA 8.3	D	157		
2.0 (TAL, TAS, TGL, TWS)	09.1985 → 09.1992	NAV	B	134	C 4331	04.2003 → 12.2005	6 CTAA 8.3	D	157		
2.5 D (TAL, TAS, TGL, TWS)	10.1988 → 09.1991	4BA	D	140	C 712 E	04.2007 → 11.2012	4 BTA 3.9	D	148		
<b>TRANSIT Van (V_)</b>						C816	01.2012 →	ISB 4.5L	D	152	
1.6 (WS)	12.1977 → 04.1981	4RB	B	118	<b>SERIES A</b>						
2.0 (VHL, VVS)	12.1977 → 10.1986	4RC	B	134	A 0509	1974 → 1983	2502 E	D	150		
2.0 (VVL)	12.1977 → 10.1986	4RC	B	134	<b>SERIES D</b>						
2.0 (VVS)	12.1977 → 07.1982	4RC	B	134	4D	01.1965 → 1981	2706 E	D	149		
						D 300	01.1965 → 1969	2700	D	149	
<b>Cargo</b>						D 300	01.1965 → 1969	2701 E	D	149	
0610	01.1969 → 1971	2711 E	D	154	D 300	01.1965 → 1969	2704 E	D	149		
0610	01.1969 → 1971	2712 E	D	154							
0610	01.1969 → 1971	2714 E	D	154	<b>6000-Serie</b>						
1114	01.1968 → 1981	360 DT	D	149	6610	09.1981 → 12.1985	BSD 444	D	155		
1115	01.1982 → 1981	360 DT	D	149	6610	09.1981 → 12.1985	BSD 444 T	D	155		
1314	01.1968 → 1981	360 DT	D	149	6700	01.1976 → 12.1980	6Y 4.2	D	155		
1315	01.1968 → 1981	360 DT	D	149	6700	01.1976 → 12.1980	7A 4.2	D	155		
1317	01.2002 → 06.2007	6 BTAA	D	147	6710	09.1981 → 12.1985	BSD 444	D	155		
1320	04.1982 → 12.1999	F 6 L 413 FZ	D	159	6710	09.1981 → 12.1985	BSD 444 T	D	155		
1515	01.1968 → 1981	360 DT	D	149	Tractor 6000	01.1971 →	6Y 4.2	D	155		
1517	01.2003 → 04.2009	6 BTAA	D	147	Tractor 6500		2715 C	D	154		
1520	04.1982 → 12.1986	F 6 L 413 FZ	D	159	<b>7000-Serie</b>						
1521	01.2003 → 01.2006	6 BTAA	D	147	7000	01.1975 → 12.1975	6Y 4.2	D	155		
1614	01.1968 → 1981	360 DT	D	149	7000	01.1975 → 12.1975	7A 4.2	D	155		
1617	04.1982 → 12.1999	F 6L 413 F	D	160	7610	09.1991 → 12.1988	BSD 444 T	D	155		
1620	04.1982 → 12.1999	F 6 L 413 FZ	D	159	7700	01.1976 → 12.1980	6Y 4.2	D	155		
1716	01.1999 → 07.2008	6 BTAA	D	147	7700	01.1976 → 12.1980	7A 4.2	D	155		
1719	09.2012 →	ISB 4.5L	D	152	7710	01.1985 → 12.1988	BSD 444 T	D	155		
1721	06.1998 →	6 BTAA	D	147	Tractor 7095		2715 E	D	154		
1729 T	01.2014 →	ISB 6.7L	D	153	Tractor 7500	01.1971 →	6Y 4.2	D	155		
1730	04.1999 → 11.2009	6 CTAA 8.3	D	157	Tractor 7500	01.1971 →	7A 4.2	D	155		
1732	04.1999 → 10.2008	6 CTAA 8.3	D	157	Tractor 7600	01.1971 →	6Y 4.2	D	155		
1816	03.2002 → 06.2007	6 BTAA	D	147	Tractor 7600	01.1971 →	7A 4.2	D	155		
1832 E	06.2007 → 11.2012	6 CTAA 8.3	D	157	<b>Cargo</b>						
1933 T	09.2012 →	ISL e	D	157	C 1723	09.2012 →	ISB 6.7L	D	153		
2014	01.1968 → 1981	360 DT	D	149	<b>LOADER</b>						
2115	01.1968 → 1981	360 DT	D	149	Loader A 62	01.1971 →	6Y 4.2	D	155		
2214	01.1968 → 1981	360 DT	D	149	Loader A 62	01.1971 →	7A 4.2	D	155		
2220	10.1982 → 03.1984	F 6 L 413 FZ	D	159	<b>SERIES 1000</b>						
2414	01.1968 → 1981	360 DT	D	149	Combine 1520		2712 E	D	154		
2420	10.1982 → 12.1999	F 6 L 413 FZ	D	159	Combine 1545		2715 E	D	154		
2423	01.2012 →	ISB 6.7L	D	153	<b>SERIES 200</b>						
						Tractor 240	01.1965 → 1968	2701 E	D	149	
						Tractor 254	01.1969 → 1981	2711 E	D	154	
						Tractor 254	01.1969 → 1981	2712 E	D	154	
						Tractor 255	01.1969 → 1981	2712 E	D	154	
						<b>SERIES 2000</b>					



				Pos					Pos
Tractor 2000	01.1965 →	2502 E	D	150	Super-Dexta	01.1965 →	2504 E	D	151
Tractor 2310	01.1965 →	2502 E	D	150	Super-Dexta	01.1965 →	ND	D	151
Tractor 2600	01.1965 →	2502 E	D	150	Super-Major	01.1952 → 1965	592 E	D	146
Tractor 2810	01.1965 →	2502 E	D	150	Super-Major	1965 →	RD	D	151
<b>SERIES 300</b>									
Tractor 330	01.1965 → 1969	2704 E	D	149					
Tractor 333	01.1965 → 12.1981	2504 E	D	151					
Tractor 353	01.1965 →	2504 E	D	151					
Tractor 380	01.1969 → 1981	2714 E	D	154					
<b>SERIES 3000</b>									
Tractor 3000	01.1965 →	2504 E	D	151					
Tractor 3600	01.1965 → 1981	2504 E	D	151					
<b>SERIES 4000</b>									
Tractor 4000	1968 →	2512 E	D	155					
Tractor 4110	01.1968 →	2512 E	D	155					
Tractor 4610	01.1968 →	2512 E	D	155					
<b>SERIES 500</b>									
Tractor 515	01.1968 →	2512 E	D	155					
Tractor 531	01.1968 →	2512 E	D	155					
Tractor 532	01.1968 →	2512 E	D	155					
Tractor 535	01.1968 →	2512 E	D	155					
Tractor 540	1968 →	2512 E	D	155					
Tractor 545	01.1968 →	2512 E	D	155					
Tractor 550	01.1968 →	2512 E	D	155					
Tractor 555	01.1968 →	2512 E	D	155					
<b>SERIES 600</b>									
Combine 630	01.1965 → 1969	2700	D	149					
Combine 630	01.1965 → 1969	2701 E	D	149					
Combine 630	01.1965 → 1969	2704 E	D	149					
Combine 640	01.1965 → 1969	2700	D	149					
Combine 640	01.1965 → 1969	2701 E	D	149					
Combine 640	01.1965 → 1969	2704 E	D	149					
<b>SERIES 700</b>									
Tractor 750	01.1971 →	6Y 4.2	D	155					
Tractor 750	01.1971 →	7A 4.2	D	155					
<b>SERIES 8000</b>									
Combine 8050	12.1986 →	2715 E	D	154					
Combine 8060	12.1986 →	2715 E	D	154					
Tractor 8000	01.1972 →	6Y 6.6	D	155					
Tractor 8000	01.1972 →	7A 6.6 81 kW	D	155					
Tractor 8060	12.1986 →	2715 E	D	154					
Tractor 8070	12.1986 →	OM 352.937	D	145					
Tractor 8100	01.1969 →	2715 E	D	154					
Tractor 8600	1972 →	6Y 6.6	D	155					
Tractor 8600	1972 →	7A 6.6 81 kW	D	155					
Tractor 8700	01.1972 →	6Y 6.6	D	155					
Tractor 8700	01.1972 →	7A 6.6 81 kW	D	155					
<b>SERIES 9000</b>									
Tractor 9600	01.1969 →	7A 6.6 102 kW	D	155					
Tractor 9700	01.1969 →	7A 6.6 102 kW	D	155					
<b>SERIES A</b>									
A 0407	01.1986 → 12.1999	NAT	B	132					
<b>SERIES D</b>									
4D Thames Trader	01.1952 → 1965	592 E	D	146					
6D	01.1965 → 1981	2703 E	D	149					
6D	01.1965 → 1981	2708 E	D	146					
6D	01.1965 → 1981	2709 E	D	149					
D 800	01.1965 → 1969	2700	D	149					
D 800	01.1965 → 1969	2701 E	D	149					
D 800	01.1965 → 1969	2704 E	D	149					
<b>SERIES TW</b>									
TW-10	01.1972 →	6Y 6.6	D	155					
TW-10	01.1972 →	7A 6.6 81 kW	D	155					
TW-20	01.1976 →	7A 6.6 102 kW	D	155					
TW-25	01.1976 →	7A 6.6 102 kW	D	155					
TW-30	01.1976 →	7A 6.6 102 kW	D	155					
TW-35	01.1976 →	7A 6.6 102 kW	D	155					
<b>TRACTOR</b>									
Major	01.1957 → 1965	592 E	D	146					

F

					Reference	Item No.
<b>1</b>		<b>69,6</b>				
<b>169A1000 Euro 4/5</b>	10.2008 → 05.2016	D (A)	4	1248 cm <sup>3</sup> 4V	55 kW (75 PS) 17,6	82,00 mm
	AS ES				BS51 6250 AA 1724837 BS51 6250 BA	<b>50 007 799</b> <b>50 007 800</b>
<b>2</b>		<b>69,6</b>				
<b>FD4 Euro 4/5</b>	10.2008 → 05.2016	D (A)	4	1248 cm <sup>3</sup> 4V	55 kW (75 PS) 17,6	82,00 mm
	IN [2] EX [2]	21,9 x 6 x 109,3 21,9 x 6 x 109,2	S - Cr - A/S - Cr -	- 45° - - - 45° - -	22 - III 22 - III	1538735 <b>291111</b> <b>291112</b>
	[50]	∅ 6 mm				<b>MK-6H</b>
	IN/EX [4]	10,03 x 6.02 x 43,0	G2			<b>81-4221</b> <small>NEW</small>
	AS ES				BS51 6250 AA 1724837 BS51 6250 BA	<b>50 007 799</b> <b>50 007 800</b>
<b>3</b>		<b>69,6</b>				
<b>BAAA Euro 4/5</b>		D (A)	4	1248 cm <sup>3</sup> 4V	55 kW (75 PS) 17,6	82,00 mm
	AS ES					<b>50 007 024</b> <small>NEW</small> (1) <b>50 007 572</b> (1)
	(1) Schalenhartguss/chilled cast iron/pièce moulée trempée en surface/fundición en coquilla/Отливка с отбелсным поверхностным слоем					
	[8]	H 12 x 34 x 34			1538733 9S516500BA	<b>50 006 438</b>
<b>4</b>		<b>70,8</b>				
<b>FP4</b>	10.2008 → 05.2016	B (NA)	4	1242 cm <sup>3</sup> 2V	51 kW (69 PS) 11,1	78,90 mm
41 754 6..						
	IN [2] EX [2]	33,2 x 5 x 99,9 28,0 x 5 x 100,5	S - Cr - RA/S- Cr -	- 45° - - - 45° - VS -	22 - III 22 - III	<b>171117</b> <b>171118</b>
	[50]	∅ 5 mm				<b>MK-5H</b>
<b>5</b>		<b>71,9</b>				
<b>DHA</b>	08.1995 → 01.2002	B (NA)	4	1242 cm <sup>3</sup> 4V	55 kW (75 PS) 10	76,50 mm
<b>DHB</b>	08.1995 → 01.2002	B (NA)	4	1242 cm <sup>3</sup> 4V	55 kW (75 PS) 10	76,50 mm
<b>DHC</b>	08.1995 → 01.2002	B (NA)	4	1242 cm <sup>3</sup> 4V	55 kW (75 PS) 10	76,50 mm
<b>DHD</b>	08.1995 → 01.2002	B (NA)	4	1242 cm <sup>3</sup> 4V	55 kW (75 PS) 10	76,50 mm
<b>DHE</b>	08.1995 → 01.2002	B (NA)	4	1242 cm <sup>3</sup> 4V	55 kW (75 PS) 10	76,50 mm
<b>DHF</b>	08.1995 → 01.2002	B (NA)	4	1242 cm <sup>3</sup> 4V	55 kW (75 PS) 10	76,50 mm
<b>DHG</b>	08.1995 → 01.2002	B (NA)	4	1242 cm <sup>3</sup> 4V	55 kW (75 PS) 10	76,50 mm
	IN/EX [4] IN/EX [4]	11,05 x 6 x 39,0 11,10 x 6 x 39,0	G2 G2			<b>81-18106</b> <b>81-18107</b>
<b>6</b>		<b>71,9</b>				
<b>FUJA</b>	05.2002 → 12.2012	B (NA)	4	1242 cm <sup>3</sup> 4V	55 kW (75 PS) 10	76,50 mm
	IN [2] EX [2]	26,1 x 6 x 99,7 22,1 x 6 x 101,7	S - Ni - RA - Ni -	- 45° - - - 45° - -	22 - 22 -	1207533 1320928 1S6G 6507 AB 1113187 1S6G 6505 AA <b>181112</b> <b>181113</b>
Fortsetzung nächste Seite / continued on next page / suite page suivante / continuación página próxima / Продолжение на следующей странице						



KOLBENSCHMIDT

TRW  
EngineComponents

FORD

					Reference	Item No.
[50]	∅ 6 mm					MK-6H
IN/EX [4]	11,05 x 6 x 39,0	G2				81-18106
IN/EX [4]	11,10 x 6 x 39,0	G2				81-18107

7

71,9

FUJB	05.2002 → 12.2012	B (NA)	4	1242 cm <sup>3</sup>	4V	55 kW	(75 PS)	10	76,50 mm
M7JA	03.2003 → 06.2008	B (NA)	4	1242 cm <sup>3</sup>	4V	51 kW	(70 PS)	10:1	76,50 mm
M7JB	03.2003 → 06.2008	B (NA)	4	1242 cm <sup>3</sup>	4V	51 kW	(70 PS)	10:1	76,50 mm
SNJA	06.2008 →	B (NA)	4	1242 cm <sup>3</sup>	4V	60 kW	(82 PS)	11	76,50 mm
SNJB	06.2008 →	B (NA)	4	1242 cm <sup>3</sup>	4V	60 kW	(82 PS)	11	76,50 mm

IN [2]	26,1 x 6 x 99,7	S - Ni -	- 45° - -	22 -	1207533 1320928 1S6G 6507 AB	181112
EX [2]	22,1 x 6 x 101,7	RA - Ni -	- 45° - -	22 -	1113187 1S6G 6505 AA	181113
[50]	∅ 6 mm					MK-6H

8

71,9

M1CA	02.2015 →	B (A)	3	998 cm <sup>3</sup>	4V	92 kW	(125 PS)	10	81,90 mm
M1CB	02.2015 →	B (A)	3	998 cm <sup>3</sup>	4V	92 kW	(125 PS)	10	81,90 mm
M1DH	10.2017 →	B (A)	3	998 cm <sup>3</sup>	4V	103 kW	(140 PS)	10	81,90 mm
M1JA	08.2012 →	B (A)	3	998 cm <sup>3</sup>	4V	88 kW	(120 PS)	10	81,90 mm
M1JC Euro 5	10.2013 →	B (A)	3	998 cm <sup>3</sup>	4V	92 kW	(125 PS)	9,9	81,90 mm
M1JE	09.2012 →	B (A)	3	998 cm <sup>3</sup>	4V	92 kW	(125 PS)	10	81,90 mm
M1JH	09.2012 →	B (A)	3	998 cm <sup>3</sup>	4V	92 kW	(125 PS)	10	81,90 mm
M1JJ Euro 6	10.2013 →	B (A)	3	998 cm <sup>3</sup>	4V	92 kW	(125 PS)	9,9	81,90 mm
M1JL Euro 5	05.2017 →	B (A)	3	998 cm <sup>3</sup>	4V	92 kW	(125 PS)	10	81,90 mm
M1JM Euro 6	05.2017 →	B (A)	3	998 cm <sup>3</sup>	4V	92 kW	(125 PS)	10	81,90 mm
M1JU Euro 5	10.2013 →	B (A)	3	998 cm <sup>3</sup>	4V	92 kW	(125 PS)	9,9	81,90 mm
M2DA Euro 5	02.2012 →	B (A)	3	998 cm <sup>3</sup>	4V	74 kW	(100 PS)	10	81,90 mm
M2DB	02.2012 →	B (A)	3	998 cm <sup>3</sup>	4V	74 kW	(100 PS)	10	81,90 mm
M2DC Euro 6	02.2012 →	B (A)	3	998 cm <sup>3</sup>	4V	74 kW	(100 PS)	10	81,90 mm
M2GA Euro 5	02.2013 →	B (A)	3	998 cm <sup>3</sup>	4V	74 kW	(100 PS)	10	81,90 mm
M2GB Euro 6	11.2013 →	B (A)	3	998 cm <sup>3</sup>	4V	74 kW	(100 PS)	10	81,90 mm
P4JA	10.2012 →	B (NA)	3	998 cm <sup>3</sup>	4V	59-63 kW	(80-86 PS)	12	81,90 mm
P4JB	10.2012 →	B (NA)	3	998 cm <sup>3</sup>	4V	59 kW	(80 PS)	12	81,90 mm
P4JC	10.2012 →	B (NA)	3	998 cm <sup>3</sup>	4V	59 kW	(80 PS)	12	81,90 mm
P4JD	10.2012 →	B (NA)	3	998 cm <sup>3</sup>	4V	59 kW	(80 PS)	12	81,90 mm
SFCA	02.2014 →	B (A)	3	998 cm <sup>3</sup>	4V	74 kW	(100 PS)	10,5	81,90 mm
SFCB	11.2013 →	B (A)	3	998 cm <sup>3</sup>	4V	74 kW	(100 PS)	10,5	81,90 mm
SFCC	02.2014 →	B (A)	3	998 cm <sup>3</sup>	4V	74 kW	(100 PS)	10,5	81,90 mm
SFCD	02.2014 →	B (A)	3	998 cm <sup>3</sup>	4V	74 kW	(100 PS)	10,5	81,90 mm
SFDA Euro 5	02.2012 →	B (A)	3	998 cm <sup>3</sup>	4V	74 kW	(100 PS)	10,5	81,90 mm
SFDB	02.2012 →	B (A)	3	998 cm <sup>3</sup>	4V	74 kW	(100 PS)	10,5	81,90 mm
SFDC Euro 6	05.2018 →	B (A)	3	998 cm <sup>3</sup>	4V	63 kW	(85 PS)	10-10,5	81,90 mm
SFJE Euro 6	05.2017 →	B (A)	3	998 cm <sup>3</sup>	4V	74 kW	(101 PS)	10,5	81,90 mm
SFJF Euro 5	05.2017 →	B (A)	3	998 cm <sup>3</sup>	4V	74 kW	(101 PS)	10	81,90 mm
SFJH Euro 6	05.2017 →	B (A)	3	998 cm <sup>3</sup>	4V	74 kW	(101 PS)	10	81,90 mm
SFJJ Euro 5	05.2017 →	B (A)	3	998 cm <sup>3</sup>	4V	74 kW	(101 PS)	10	81,90 mm
SFJK Euro 6	05.2017 →	B (A)	3	998 cm <sup>3</sup>	4V	74 kW	(101 PS)	10,5	81,90 mm
SFJL Euro 6	04.2018 →	B (A)	3	998 cm <sup>3</sup>	4V	74 kW	(100 PS)	10-10,5	81,90 mm
SFJN Euro 6	05.2017 →	B (A)	3	998 cm <sup>3</sup>	4V	74 kW	(101 PS)	10-10,5	81,90 mm
SFJP Euro 6	05.2017 →	B (A)	3	998 cm <sup>3</sup>	4V	74 kW	(101 PS)	10-10,5	81,90 mm
XMJA	01.2013 →	B (A)	3	998 cm <sup>3</sup>	4V	48 kW	(65 PS)	12	81,90 mm
XMJB	01.2013 →	B (A)	3	998 cm <sup>3</sup>	4V	48 kW	(65 PS)	12	81,90 mm
YYJA	05.2014 →	B (A)	3	998 cm <sup>3</sup>	4V	103 kW	(140 PS)	9,9	81,90 mm
YYJB	05.2014 →	B (A)	3	998 cm <sup>3</sup>	4V	103 kW	(140 PS)	9,9	81,90 mm
YYJC	02.2016 →	B (A)	3	998 cm <sup>3</sup>	4V	103 kW	(140 PS)	9,9	81,90 mm
YYJD Euro 5	03.2016 →	B (A)	3	998 cm <sup>3</sup>	4V	103 kW	(140 PS)	9,9	81,90 mm
YYJE Euro 6	06.2017 →	B (A)	3	998 cm <sup>3</sup>	4V	103 kW	(140 PS)	9,9	81,90 mm

41 949 6..

Fortsetzung nächste Seite / continued on next page / suite page suivante / continuación página próxima / Продолжение на следующей странице

					Reference	Item No.
IN [2]	27,1 x 5 x 96,2	S - Ni -	- 45° - -	22 - III	1760579 CM5G 6507 CB	<b>181120</b> <small>NEW</small>
EX [2]	23,1 x 5 x 98,2	ID/S - Cr -	- 45° - -	22 - III	1760588 CM5G 6505 EA	<b>181118</b> <small>NEW</small>
IN/EX [1]	9,53 x 5 x 36,0	B1				<b>81-18113</b> <small>NEW</small>

## 9 71,9

<b>M1DA Euro 5</b>	02.2012 →	B (A)	3	998 cm <sup>3</sup>	4V	92 kW	(125 PS)	10	81,90 mm
<b>M1DC</b>	02.2012 →	B (A)	3	998 cm <sup>3</sup>	4V	92 kW	(125 PS)	10	81,90 mm
<b>M1DD Euro 6</b>	02.2012 →	B (A)	3	998 cm <sup>3</sup>	4V	92 kW	(125 PS)	10	81,90 mm
<b>SFJA</b>	10.2012 →	B (A)	3	998 cm <sup>3</sup>	4V	74 kW	(101 PS)	10,5	81,90 mm
<b>SFJB</b>	10.2012 →	B (A)	3	998 cm <sup>3</sup>	4V	74 kW	(101 PS)	10,5	81,90 mm
<b>SFJC</b>	10.2012 →	B (A)	3	998 cm <sup>3</sup>	4V	74 kW	(100 PS)	10,5	81,90 mm
<b>SFJD</b>	10.2012 →	B (A)	3	998 cm <sup>3</sup>	4V	74 kW	(100 PS)	10	81,90 mm

41 949 6..

IN [2]	27,1 x 5 x 96,2	S - Ni -	- 45° - -	22 - III	1760579 CM5G 6507 CB	<b>181120</b> <small>NEW</small>
EX [2]	23,1 x 5 x 98,2	ID/S - Cr -	- 45° - -	22 - III	1760588 CM5G 6505 EA	<b>181118</b> <small>NEW</small>
IN/EX [1]	9,53 x 5 x 36,0	B1				<b>81-18113</b> <small>NEW</small>
AS					1771608 CM5G-6C525-DC	<b>50 007 778</b>

## 10 71,9

<b>B3DA Euro 6</b>	10.2012 →	B (A)	3	999 cm <sup>3</sup>	4V	74 kW	(101 PS)	10,5	82,00 mm
<b>B3GA Euro 6</b>	05.2018 →	B (A)	3	998 cm <sup>3</sup>	4V	74 kW	(100 PS)		81,90 mm
<b>B7DA Euro 6</b>	10.2012 →	B (A)	3	999 cm <sup>3</sup>	4V	92 kW	(125 PS)	10,5	82,00 mm
<b>B7JA Euro 6</b>	09.2019 →	B (A)	3	999 cm <sup>3</sup>	4V	92 kW	(125 PS)		82,00 mm
<b>B7JB Euro 6</b>	09.2019 →	B (A)	3	999 cm <sup>3</sup>	4V	92 kW	(125 PS)		82,00 mm
<b>B7JC Euro 6</b>	11.2019 →	B (A)	3	999 cm <sup>3</sup>	4V	92 kW	(125 PS)		82,00 mm
<b>BZJA Euro 6</b>	09.2019 →	B (A)	3	999 cm <sup>3</sup>	4V	114 kW	(155 PS)		82,00 mm
<b>M0JA Euro 6</b>	09.2019 →	B (A)	3	999 cm <sup>3</sup>	4V	70 kW	(95 PS)		82,00 mm

[50]	∅ 5,5 mm								<b>MK-5.5H</b>
------	----------	--	--	--	--	--	--	--	----------------

					Reference	Item No.		
<b>11</b>		<b>73,5</b>						
<b>15DSOX</b>	01.2011 →	D (A)	4	1499 cm <sup>3</sup>	2V	66-74 kW (91-101 PS)	88,30 mm	
<b>UGCB</b>	01.2014 →	D (A)	4	1499 cm <sup>3</sup>	2V	55 kW (75 PS)	88,30 mm	
<b>UGCC</b>	03.2015 →	D (LA)	4	1499 cm <sup>3</sup>	2V	88 kW (120 PS)	88,30 mm	
<b>UGJE</b>	10.2012 →	D (A)	4	1499 cm <sup>3</sup>	2V	66-67 kW (90-91 PS)	88,30 mm	
<b>UGJG</b>	10.2012 →	D (A)	4	1499 cm <sup>3</sup>	2V	55 kW (75 PS)	88,30 mm	
<b>UGJM</b>	05.2015 →	D (A)	4	1499 cm <sup>3</sup>	2V	74 kW (100 PS)	88,30 mm	
<b>XUCA</b>	03.2015 →	D (LA)	4	1499 cm <sup>3</sup>	2V	88 kW (120 PS)	16 88,30 mm	
<b>XUCC</b>	01.2014 →	D (LA)	4	1499 cm <sup>3</sup>	2V	55 kW (75 PS)	16 88,30 mm	
<b>XUCD</b>	01.2014 →	D (LA)	4	1499 cm <sup>3</sup>	2V	55 kW (75 PS)	16 88,30 mm	
<b>XUJA Euro 6</b>	09.2012 →	D (LA)	4	1499 cm <sup>3</sup>	2V	55 kW (75 PS)	16 88,30 mm	
<b>XUJB Euro 6</b>	09.2012 →	D (LA)	4	1499 cm <sup>3</sup>	2V	55 kW (75 PS)	16 88,30 mm	
<b>XUJC Euro 6</b>	05.2017 →	D (LA)	4	1499 cm <sup>3</sup>	2V	63 kW (86 PS)	16 88,30 mm	
<b>XUJD Euro 5</b>	05.2017 →	D (LA)	4	1499 cm <sup>3</sup>	2V	63 kW (86 PS)	16 88,30 mm	
<b>XUJE Euro 5</b>	05.2017 →	D (LA)	4	1499 cm <sup>3</sup>	2V	63 kW (86 PS)	16 88,30 mm	
<b>XUJF Euro 6</b>	05.2017 →	D (LA)	4	1499 cm <sup>3</sup>	2V	63 kW (86 PS)	16 88,30 mm	
<b>XUJG Euro 6</b>	05.2017 →	D (LA)	4	1499 cm <sup>3</sup>	2V	63 kW (86 PS)	16 88,30 mm	
<b>XUJH Euro 6</b>	05.2015 →	D (LA)	4	1499 cm <sup>3</sup>	2V	74 kW (100 PS)	88,30 mm	
<b>XUJK Euro 6</b>	05.2017 →	D (LA)	4	1499 cm <sup>3</sup>	2V	63 kW (86 PS)	16 88,30 mm	
<b>XUJL Euro 6</b>	05.2017 →	D (LA)	4	1499 cm <sup>3</sup>	2V	63 kW (86 PS)	16 88,30 mm	
<b>XUJM Euro 6</b>	05.2017 →	D (LA)	4	1499 cm <sup>3</sup>	2V	63 kW (86 PS)	16 88,30 mm	
<b>XUJN Euro 6</b>	05.2017 →	D (LA)	4	1499 cm <sup>3</sup>	2V	63 kW (86 PS)	16 88,30 mm	
<b>XVCA</b>	05.2015 →	D (LA)	4	1499 cm <sup>3</sup>	2V	70 kW (95 PS)	16 88,30 mm	
<b>XVCB</b>	05.2015 →	D (LA)	4	1499 cm <sup>3</sup>	2V	70 kW (95 PS)	16 88,30 mm	
<b>XVCC</b>	05.2015 →	D (LA)	4	1499 cm <sup>3</sup>	2V	70 kW (95 PS)	16 88,30 mm	
<b>XVGA Euro 6</b>	05.2015 →	D (A)	4	1499 cm <sup>3</sup>	2V	74 kW (101 PS)	16 88,30 mm	
<b>XVGB Euro 6</b>	05.2015 →	D (A)	4	1499 cm <sup>3</sup>	2V	74 kW (101 PS)	16 88,30 mm	
<b>XVGC Euro 6</b>	05.2015 →	D (A)	4	1499 cm <sup>3</sup>	2V	74 kW (101 PS)	16 88,30 mm	
<b>XVJA</b>	04.2015 →	D (LA)	4	1499 cm <sup>3</sup>	2V	70 kW (95 PS)	16 88,30 mm	
<b>XVJB</b>	05.2015 →	D (LA)	4	1499 cm <sup>3</sup>	2V	70 kW (95 PS)	16 88,30 mm	
<b>XVJC</b>	04.2015 →	D (LA)	4	1499 cm <sup>3</sup>	2V	70 kW (95 PS)	16 88,30 mm	
<b>XVJD</b>	05.2015 →	D (A)	4	1499 cm <sup>3</sup>	2V	70 kW (95 PS)	16 88,30 mm	
<b>XVJE Euro 6</b>		D (LA)	4	1499 cm <sup>3</sup>	2V	63 kW (86 PS)	16 88,30 mm	
<b>XWCA Euro 6</b>	04.2018 →	D (LA)	4	1499 cm <sup>3</sup>	2V	55 kW (75 PS)	16 88,30 mm	
<b>XWCB Euro 6</b>	04.2018 →	D (LA)	4	1499 cm <sup>3</sup>	2V	55 kW (75 PS)	16 88,30 mm	
<b>XWDE</b>	09.2014 →	D (LA)	4	1499 cm <sup>3</sup>	2V	88 kW (120 PS)	16,1 88,30 mm	
<b>XWGA Euro 6</b>	05.2015 →	D (A)	4	1499 cm <sup>3</sup>	2V	88 kW (120 PS)	88,30 mm	
<b>XWGB Euro 6</b>	05.2015 →	D (A)	4	1499 cm <sup>3</sup>	2V	88 kW (120 PS)	88,30 mm	
<b>XWGC Euro 4</b>	05.2015 →	D (A)	4	1499 cm <sup>3</sup>	2V	88 kW (120 PS)	88,30 mm	
<b>XWJA Euro 5</b>	05.2017 →	D (LA)	4	1499 cm <sup>3</sup>	2V	88 kW (120 PS)	16 88,30 mm	
<b>XWJB Euro 6</b>	05.2017 →	D (LA)	4	1499 cm <sup>3</sup>	2V	88 kW (120 PS)	16 88,30 mm	
<b>XWJC Euro 6</b>	05.2017 →	D (LA)	4	1499 cm <sup>3</sup>	2V	88 kW (120 PS)	16 88,30 mm	
<b>XWMB Euro 6</b>	07.2016 →	D (LA)	4	1499 cm <sup>3</sup>	2V	88 kW (120 PS)	16 88,30 mm	
<b>XWMC Euro 6</b>	07.2016 →	D (LA)	4	1499 cm <sup>3</sup>	2V	88 kW (120 PS)	16 88,30 mm	
<b>XXCA</b>	04.2018 →	D (LA)	4	1499 cm <sup>3</sup>	2V	74 kW (100 PS)	16 88,30 mm	
<b>XXCB</b>	04.2018 →	D (LA)	4	1499 cm <sup>3</sup>	2V	74 kW (100 PS)	16 88,30 mm	
<b>XXCC</b>	04.2018 →	D (LA)	4	1499 cm <sup>3</sup>	2V	74 kW (100 PS)	16 88,30 mm	
<b>XXGA Euro 6</b>	05.2015 →	D (A)	4	1499 cm <sup>3</sup>	2V	74 kW (101 PS)	88,30 mm	
	IN [2]	30,0 x 5,5 x 95,5	S - Cr -	- 45° -	-	22 - III	1685847	<b>539046</b>
	EX [2]	27,6 x 5,5 x 95,5	RA/S- Cr -	- 45° -	VS -	22 - III	1685845	<b>539047</b>
							AV6Q 6507 AA	
							AV6Q 6505 AA	
	[50]	Ø 5,5 mm						<b>MK-5.5H</b>
	IN/EX [4]	9,55 x 5.51 x 34,0	G1					<b>81-18111</b>

F



					Reference	Item No.			
<b>12</b>		<b>73,5</b>							
AEDA	09.2014 →	D (A)	4	1499 cm <sup>3</sup>	2V	77 kW (105 PS)	16	88,30 mm	
UGCA	01.2014 →	D (A)	4	1499 cm <sup>3</sup>	2V	55 kW (75 PS)	16	88,30 mm	
UGJC	09.2012 →	D (A)	4	1499 cm <sup>3</sup>	2V	55 kW (75 PS)		88,30 mm	
XWDA	09.2014 →	D (LA)	4	1499 cm <sup>3</sup>	2V	88 kW (120 PS)	16,1	88,30 mm	
XWDB	09.2014 →	D (LA)	4	1499 cm <sup>3</sup>	2V	88 kW (120 PS)	16,1	88,30 mm	
XWDC	09.2014 →	D (LA)	4	1499 cm <sup>3</sup>	2V	88 kW (120 PS)	16,1	88,30 mm	
XWDD	09.2014 →	D (LA)	4	1499 cm <sup>3</sup>	2V	88 kW (120 PS)	16,1	88,30 mm	
XXDA	09.2014 →	D (LA)	4	1499 cm <sup>3</sup>	2V	70 kW (95 PS)	16,1	88,30 mm	
XXDB	09.2014 →	D (LA)	4	1499 cm <sup>3</sup>	2V	77 kW (105 PS)	16,1	88,30 mm	
XXDC	09.2014 →	D (LA)	4	1499 cm <sup>3</sup>	2V	70 kW (95 PS)	16,1	88,30 mm	
	IN [2]	30,0 x 5,5 x 95,5	S - Cr -	- 45° -	-	22 - III	1685847 AV6Q 6507 AA	<b>539046</b>	
	EX [2]	27,6 x 5,5 x 95,5	RA/S- Cr -	- 45° -	VS -	22 - III	1685845 AV6Q 6505 AA	<b>539047</b>	
	[50]	∅ 5,5 mm						<b>MK-5.5H</b>	
	IN/EX [4]	9,55 x 5.51 x 34,0	G1					<b>81-18111</b>	
	[8]	H 12 x 34,6 x 34,6					1487788 2S6Q6500AA 2S6Q6500AB 4S7Q6C501AA	<b>50 006 432</b>	
<b>13</b>		<b>73,7</b>							
F6JA	11.2001 → 12.2012	D (A)	4	1399 cm <sup>3</sup>	2V	50-51 kW (68-69 PS)	17,9-18	82,00 mm	
F6JB	11.2001 →	D (A)	4	1399 cm <sup>3</sup>	2V	50 kW (68 PS)	17,9	82,00 mm	
F6JC	05.2002 → 11.2011	D (A)	4	1399 cm <sup>3</sup>	2V	50 kW (68 PS)	17,9	82,00 mm	
40 469 6..									
	IN [2]	32,8 x 5,5 x 97,4	S - Cr -	- 45° -	-	22 - III	1145933 1152191 1639605 2S6Q 6507 A9B 2S6Q 6507 AA 2S6Q 6507 AB	<b>181102</b>	
	EX [2]	30,2 x 5,5 x 97,4	A/S - Cr -	- 45° -	-	22 - III	1145932 1152190 1202362 2S6Q 6505 AA 2S6Q 6505 AB 2S6Q 6505 AC	<b>181103</b>	
	[50]	∅ 5,5 mm						<b>MK-5.5H</b>	
	IN/EX [4]	9,55 x 5.51 x 34,0	G1					<b>81-18111</b>	
							1386533 2S6Q 6250 AD 1386533 2S6Q 6250 AD	<b>50 007 081</b> (1) <b>50 007 083</b> (2)	
	(1) (ST)								
	(2) gegossene Version / cast Version / version coule / versión fundida / литая версия								
	[8]	H 12 x 34,5					1146061 1487788 2S6Q6500AA 2S6Q6500AB 4S7Q6C501AA	<b>50 006 419</b> <b>50 006 432</b>	
	[8]	H 12 x 34,6 x 34,6							
Fortsetzung nächste Seite / continued on next page / suite page suivante / continuación página próxima / Продолжение на следующей странице									

					Reference	Item No.	
[4]					1145959 2S6Q-6564-AA	50 006 172	
<b>14</b>	<b>73,7</b>						
<b>KVJA</b>	05.2002 →	D (LA)	4	1399 cm <sup>3</sup> 2V	50-51 kW (68-69 PS) 17,9	82,00 mm	
IN [2]	32,8 x 5,5 x 97,4	S - Cr -		- 45° - -	22 - III	1145933 1152191 1639605 2S6Q 6507 A9B 2S6Q 6507 AA 2S6Q 6507 AB	<b>181102</b>
EX [2]	30,2 x 5,5 x 97,4	A/S - Cr -		- 45° - -	22 - III	1145932 1152190 1202362 2S6Q 6505 AA 2S6Q 6505 AB 2S6Q 6505 AC	<b>181103</b>
[50]	Ø 5,5 mm						<b>MK-5.5H</b>
IN/EX [4]	10,03 x 6.02 x 43,0	G2					<b>81-4221</b> <small>NEW</small>
IN/EX [4]	9,55 x 5.51 x 34,0	G1					<b>81-18111</b> <small>NEW</small>
[8]	H 12 x 34,6 x 34,6					1487788 2S6Q6500AA 2S6Q6500AB 4S7Q6C501AA	<b>50 006 432</b>
<b>15</b>	<b>73,7</b>						
<b>F6JD</b>	01.2009 →	D (LA)	4	1399 cm <sup>3</sup> 2V	50-51 kW (68-70 PS) 17,9	82,00 mm	
IN [2]	32,8 x 5,5 x 97,4	S - Cr -		- 45° - -	22 - III	1145933 1152191 1639605 2S6Q 6507 A9B 2S6Q 6507 AA 2S6Q 6507 AB	<b>181102</b>
EX [2]	30,2 x 5,5 x 97,4	A/S - Cr -		- 45° - -	22 - III	1145932 1152190 1202362 2S6Q 6505 AA 2S6Q 6505 AB 2S6Q 6505 AC	<b>181103</b>
[50]	Ø 5,5 mm						<b>MK-5.5H</b>
IN/EX [4]	10,03 x 6.02 x 43,0	G2					<b>81-4221</b> <small>NEW</small>
IN/EX [4]	9,55 x 5.51 x 34,0	G1					<b>81-18111</b> <small>NEW</small>
<b>16</b>	<b>73,96</b>						
<b>GLA</b>	05.1976 → 11.1986	B (NA)	4	1117 cm <sup>3</sup> 2V	39-40 kW (53-54 PS) 9	64,98 mm	
IN/EX [4]	13,57 x 8 x 67,9	G1				81SM 6510 LC	<b>81-18104</b>
<b>17</b>	<b>73,96</b>						
<b>JLA</b>	12.1985 → 03.1989	B (NA)	4	1297 cm <sup>3</sup> 2V	44 kW (60 PS) 9,3	75,48 mm	
[50]	Ø 8 mm						<b>MK-8H</b>
IN/EX [4]	13,57 x 8 x 67,9	G1				81SM 6510 LC	<b>81-18104</b>

Fortsetzung nächste Seite / continued on next page / suite page suivante / continuación página próxima / Продолжение на следующей странице

					Reference	Item No.
					1614766 81SM 6251 KE	<b>50 006 259</b> (1)
(1) Schalenhartguss/chilled cast iron/pièce moulée trempée en surface/fundición en coquilla/Отливка с отбеленным поверхностным слоем						
<b>18</b>		<b>74</b>				
GL1	10.1977 → 11.1986	B (NA)	4	1117 cm <sup>3</sup>	2V 39 kW (53 PS)	9,5 65,00 mm
GLB	09.1980 → 02.1986	B (NA)	4	1117 cm <sup>3</sup>	2V 37-40 kW (50-55 PS)	9,5 65,00 mm
GLW	02.1981 → 08.1983	B (NA)	4	1117 cm <sup>3</sup>	2V 39-40 kW (53-55 PS)	9 65,00 mm
	IN/EX [4]	13,57 x 8 x 67,9	G1			81SM 6510 LC <b>81-18104</b>
<b>19</b>		<b>74</b>				
GMA	09.1980 → 08.1983	B (NA)	4	1117 cm <sup>3</sup>	2V 40 kW (55 PS)	8,5 65,00 mm
GPA	09.1980 → 08.1983	B (NA)	4	1117 cm <sup>3</sup>	2V 43 kW (59 PS)	9,5 65,00 mm
	IN/EX [4]	13,57 x 8 x 67,9	G1			81SM 6510 LC <b>81-18104</b>
	[8]	H 22,2 x 49,5				6129778 6129780 <b>50 006 477</b>
<b>20</b>		<b>75</b>				
G8DD	10.2003 → 09.2012	D (LA)	4	1560 cm <sup>3</sup>	4V 80 kW (109 PS)	17,6 88,30 mm
	IN [2]	25,6 x 5,5 x 96,4	S - Cr -	- 45° - -	22 - III	1229882 3M5Q 6507 AA <b>539009</b>
	EX [2]	23,4 x 5,5 x 96,6	A/S - Cr -	- 45° - VS -	22 - III	1229883 3M5Q 6505 AA <b>539010</b>
	[50]	∅ 5,5 mm				<b>MK-5.5H</b>
	IN/EX [4]	9,55 x 5.51 x 34,0	G1			<b>81-18111</b> <small>NEW</small>
<b>21</b>		<b>75</b>				
G8DE	10.2003 → 09.2012	D (LA)	4	1560 cm <sup>3</sup>	4V 80 kW (109 PS)	17,6:1 88,30 mm
G8DF	10.2003 → 09.2012	D (LA)	4	1560 cm <sup>3</sup>	4V 80 kW (109 PS)	17,6:1 88,30 mm
	IN [2]	25,6 x 5,5 x 96,4	S - Cr -	- 45° - -	22 - III	1229882 3M5Q 6507 AA <b>539009</b>
	EX [2]	23,4 x 5,5 x 96,6	A/S - Cr -	- 45° - VS -	22 - III	1229883 3M5Q 6505 AA <b>539010</b>
	[50]	∅ 5,5 mm				<b>MK-5.5H</b>
	IN/EX [4]	9,55 x 5.51 x 34,0	G1			<b>81-18111</b> <small>NEW</small>
	[8]	H 12 x 34,6 x 34,6				1487788 2S6Q6500AA 2S6Q6500AB 4S7Q6C501AA <b>50 006 432</b>

					Reference	Item No.			
<b>22</b>		<b>75</b>							
<b>G8DA</b>	10.2003 → 09.2012	D (LA)	4	1560 cm <sup>3</sup>	4V	80 kW (109 PS)	18,3	88,30 mm	
<b>G8DB</b>	10.2003 → 09.2012	D (LA)	4	1560 cm <sup>3</sup>	4V	80 kW (109 PS)	18,3	88,30 mm	
<b>G8DC</b>	07.2004 → 09.2012	D (LA)	4	1560 cm <sup>3</sup>	4V	74 kW (100 PS)		88,30 mm	
<b>GPDA Euro 4</b>	07.2004 → 09.2012	D (LA)	4	1560 cm <sup>3</sup>	4V	66 kW (90 PS)	18,3	88,30 mm	
<b>GPDC Euro 4</b>	07.2004 → 09.2012	D (LA)	4	1560 cm <sup>3</sup>	4V	66 kW (90 PS)	18,3	88,30 mm	
<b>HHDA Euro 4</b>	07.2004 → 09.2012	D (LA)	4	1560 cm <sup>3</sup>	4V	66 kW (90 PS)	18,3	88,30 mm	
<b>HHDB Euro 4</b>	07.2004 → 09.2012	D (LA)	4	1560 cm <sup>3</sup>	4V	66 kW (90 PS)	18,3	88,30 mm	
<b>HHJA</b>	11.2004 → 12.2012	D (A)	4	1560 cm <sup>3</sup>	4V	66 kW (90 PS)	18	88,30 mm	
<b>HHJB</b>	11.2004 → 12.2012	D (A)	4	1560 cm <sup>3</sup>	4V	66 kW (90 PS)	18	88,30 mm	
<b>HHJC</b>	06.2008 →	D (LA)	4	1560 cm <sup>3</sup>	4V	66 kW (90 PS)	18	88,30 mm	
<b>HHJD</b>	04.2007 →	D (LA)	4	1560 cm <sup>3</sup>	4V	66 kW (90 PS)	18	88,30 mm	
<b>HHJE</b>	06.2008 →	D (LA)	4	1560 cm <sup>3</sup>	4V	66 kW (90 PS)	18	88,30 mm	
<b>HHJF</b>	06.2008 →	D (A)	4	1560 cm <sup>3</sup>	4V	55 kW (75 PS)	18	88,30 mm	
<b>MTDA</b>	07.2004 → 09.2012	D (LA)	4	1560 cm <sup>3</sup>	4V	74 kW (100 PS)		88,30 mm	
<b>UBJA</b>	06.2008 →	D (A)	4	1560 cm <sup>3</sup>	4V	55 kW (75 PS)		88,30 mm	
40 179 6..									
	IN [2]	25,6 x 5,5 x 96,4	S - Cr -	- 45° -	-	22 - III	1229882 3M5Q 6507 AA	<b>539009</b>	
	EX [2]	23,4 x 5,5 x 96,6	A/S - Cr -	- 45° -	VS -	22 - III	1229883 3M5Q 6505 AA	<b>539010</b>	
	[50]	∅ 5,5 mm						<b>MK-5.5H</b>	
	IN/EX [4]	9,55 x 5.51 x 34,0	G1					<b>81-18111</b> <small>NEW</small>	
		ES					1313804 3M5Q6A270AC	<b>50 007 093</b> <small>NEW</small> (1)	
		AS					1313805 3M5Q6A273AC	<b>50 007 094</b> <small>NEW</small> (1)	
		ES					1313804 3M5Q6A270AC	<b>50 007 573</b> (2)	
		AS					1313805 3M5Q6A273AC	<b>50 007 574</b> (2)	
	(1)	gegossene Version / cast Version / version coule / versión fundida / литая версия							
	(2)	(ST)							
	[8]	H 12 x 34,5 x 33,4					1319249 3M5Q6500BA	<b>50 006 433</b>	
	[4]						1231272 3M5Q 6564 AA	<b>50 006 485</b>	
<b>23</b>		<b>75</b>							
<b>T1BA</b>	12.2010 → 01.2015	D (LA)	4	1560 cm <sup>3</sup>	2V	85 kW (116 PS)	16,0:1	88,30 mm	
<b>T1BB</b>	12.2010 → 01.2015	D (LA)	4	1560 cm <sup>3</sup>	2V	85 kW (116 PS)	16,0:1	88,30 mm	
<b>T1BC</b>	12.2010 → 01.2015	D (LA)	4	1560 cm <sup>3</sup>	2V	85 kW (115 PS)	16,0:1	88,30 mm	
<b>T1DA</b>	07.2010 →	D (LA)	4	1560 cm <sup>3</sup>	2V	85 kW (115 PS)	16	88,30 mm	
<b>T1DB</b>	07.2010 →	D (LA)	4	1560 cm <sup>3</sup>	2V	85 kW (115 PS)	16	88,30 mm	
<b>T3DA</b>	07.2010 →	D (LA)	4	1560 cm <sup>3</sup>	2V	70 kW (95 PS)	16,0:1	88,30 mm	
<b>T3DB</b>	07.2010 →	D (LA)	4	1560 cm <sup>3</sup>	2V	70 kW (95 PS)	16,0:1	88,30 mm	
<b>TZJA</b>	02.2010 →	D (A)	4	1560 cm <sup>3</sup>	2V	70 kW (95 PS)		88,30 mm	
<b>TZJB</b>	02.2010 →	D (A)	4	1560 cm <sup>3</sup>	2V	70 kW (95 PS)		88,30 mm	
41 253 6..									
	IN [2]	30,0 x 5,5 x 95,5	S - Cr -	- 45° -	-	22 - III	1685847 AV6Q 6507 AA	<b>539046</b> <small>NEW</small>	
	EX [2]	27,6 x 5,5 x 95,5	RA/S- Cr -	- 45° -	VS -	22 - III	1685845 AV6Q 6505 AA	<b>539047</b> <small>NEW</small>	
	[50]	∅ 5,5 mm						<b>MK-5.5H</b>	
Fortsetzung nächste Seite / continued on next page / suite page suivante / continuación página próxima / Продолжение на следующей странице									

					Reference	Item No.
	IN/EX [4] 9,55 x 5.51 x 34,0	G1				<b>81-18111</b> <small>NEW</small>
	(1) (ST)				1685737	<b>50 007 674</b> (1)
	[8] H 12 x 34,6 x 34,6				1487788 2S6Q6500AA 2S6Q6500AB 4S7Q6C501AA	<b>50 006 432</b>

**F**
**24**
**75**

**T3JA** 02.2010 → D (A) 4 1560 cm<sup>3</sup> 2V 70 kW (95 PS) 88,30 mm  
41 253 6..

	IN [2] 30,0 x 5,5 x 95,5	S - Cr -	- 45° - -	22 - III	1685847 AV6Q 6507 AA	<b>539046</b> <small>NEW</small>
	EX [2] 27,6 x 5,5 x 95,5	RA/S- Cr -	- 45° - VS -	22 - III	1685845 AV6Q 6505 AA	<b>539047</b> <small>NEW</small>
	[50] Ø 5,5 mm					<b>MK-5.5H</b>
	IN/EX [4] 9,55 x 5.51 x 34,0	G1				<b>81-18111</b> <small>NEW</small>
	IN/EX [1] 9,53 x 5 x 36,0	B1				<b>81-18113</b> <small>NEW</small>
	[8] H 12 x 34,6 x 34,6				1487788 2S6Q6500AA 2S6Q6500AB 4S7Q6C501AA	<b>50 006 432</b>

**25**
**75**

**NGDA** 05.2012 → D (LA) 4 1560 cm<sup>3</sup> 2V 77 kW (105 PS)  
**T1WA** 02.2011 → 06.2015 D (LA) 4 1560 cm<sup>3</sup> 2V 85 kW (115 PS) 88,30 mm  
**T1WB** 02.2011 → 06.2015 D (LA) 4 1560 cm<sup>3</sup> 2V 85 kW (115 PS) 16 88,30 mm  
**T3CA** 01.2014 → D (A) 4 1560 cm<sup>3</sup> 2V 70 kW (95 PS) 88,30 mm

	IN [2] 30,0 x 5,5 x 95,5	S - Cr -	- 45° - -	22 - III	1685847 AV6Q 6507 AA	<b>539046</b> <small>NEW</small>
	EX [2] 27,6 x 5,5 x 95,5	RA/S- Cr -	- 45° - VS -	22 - III	1685845 AV6Q 6505 AA	<b>539047</b> <small>NEW</small>
	[50] Ø 5,5 mm					<b>MK-5.5H</b>
	IN/EX [4] 9,55 x 5.51 x 34,0	G1				<b>81-18111</b> <small>NEW</small>
	[8] H 12 x 34,6 x 34,6				1487788 2S6Q6500AA 2S6Q6500AB 4S7Q6C501AA	<b>50 006 432</b>

**26**
**75**

**NGCA** 09.2014 → D (A) 4 1560 cm<sup>3</sup> 2V 85 kW (115 PS) 16 88,30 mm  
**T3CB** 01.2014 → D (A) 4 1560 cm<sup>3</sup> 2V 70 kW (95 PS) 88,30 mm  
**T3CC** 01.2014 → D (LA) 4 1560 cm<sup>3</sup> 2V 70 kW (95 PS) 88,30 mm  
**T3JB** 10.2012 → D (A) 4 1560 cm<sup>3</sup> 2V 70 kW (95 PS) 88,30 mm  
**U3CA** 09.2014 → D (A) 4 1560 cm<sup>3</sup> 2V 85 kW (115 PS) 16 88,30 mm  
**Z2JA Euro 6** 11.2017 → D (LA) 4 1499 cm<sup>3</sup> 4V 74 kW (100 PS) 84,80 mm  
**ZTJA Euro 6** 11.2017 → D (LA) 4 1499 cm<sup>3</sup> 4V 92 kW (125 PS) 84,80 mm  
**ZTJB Euro 6** 11.2017 → D (LA) 4 1499 cm<sup>3</sup> 4V 92 kW (125 PS) 84,80 mm  
**ZTJC Euro 6** 11.2017 → D (LA) 4 1499 cm<sup>3</sup> 4V 92 kW (125 PS) 84,80 mm

41 253 6..

Fortsetzung nächste Seite / continued on next page / suite page suivante / continuación página próxima / Продолжение на следующей странице



					Reference	Item No.	
	IN [2] EX [2]	30,0 x 5,5 x 95,5 27,6 x 5,5 x 95,5	S - Cr - RA/S- Cr -	- 45° - - - 45° - VS -	22 - III 22 - III	1685847 AV6Q 6507 AA 1685845 AV6Q 6505 AA	<b>539046</b> <small>NEW</small> <b>539047</b> <small>NEW</small>
	[50]	Ø 5,5 mm					<b>MK-5.5H</b>
	IN/EX [4]	9,55 x 5.51 x 34,0	G1				<b>81-18111</b> <small>NEW</small>
<b>27</b>		<b>76</b>	<b>LUH</b> 01.1989 → 01.1994 B (NA) 4 1597 cm <sup>3</sup> 2V 65-66 kW (88-90 PS) 10,3 88,00 mm 94 916 6..				
	EX [2]	24,5 x 6 x 96,6	A/S - Cr -	- 45° - -	1 - III	1023591 7314594 7314599 928M 6505 C2A 948M 6505 A2A	<b>105-35514</b>
	IN/EX [4] IN/EX [4]	11,05 x 6 x 39,0 11,10 x 6 x 39,0	G2 G2				<b>81-18106</b> <b>81-18107</b>
	[8]	H 22,2 x 49,5				6129778 6129780	<b>50 006 477</b>
<b>28</b>		<b>76</b>	<b>FHD</b> 11.1997 → 10.2000 B (NA) 4 1388 cm <sup>3</sup> 4V 66 kW (90 PS) 10,3 76,50 mm <b>L1E</b> 07.1992 → 07.2000 B (NA) 4 1597 cm <sup>3</sup> 4V 66 kW (90 PS) 10,3 88,00 mm <b>L1F</b> 02.1993 → 08.1996 B (NA) 4 1597 cm <sup>3</sup> 4V 66 kW (90 PS) 10,3 88,00 mm <b>L1G</b> 01.1994 → 12.1995 B (NA) 4 1597 cm <sup>3</sup> 4V 65-66 kW (88-90 PS) 10,3 88,00 mm <b>L1J</b> 07.1994 → 09.2000 B (NA) 4 1597 cm <sup>3</sup> 4V 65-66 kW (88-90 PS) 10,3 88,00 mm 94 916 6..				
	EX [2]	24,5 x 6 x 96,6	A/S - Cr -	- 45° - -	1 - III	1023591 7314594 7314599 928M 6505 C2A 948M 6505 A2A	<b>105-35514</b>
	IN/EX [4]	12,03 x 6.08 x 36,0	G2				<b>81-18105</b>
	[8]	H 28,4 x 26				1003734 1007308 1037330 1037331 1043175 6804674 6945586 938M-6500A-1D 938M-6500A-1E 938M-6500A-2E 938M-6500A-2F 938M6500A1D F5RZ 6500 BA	<b>50 007 597</b>
<b>29</b>		<b>76</b>	<b>L1K</b> 08.1993 → 08.2002 B (NA) 4 1597 cm <sup>3</sup> 4V 66-70 kW (90-95 PS) 10,3 88,00 mm <b>L1L</b> 05.1998 → 09.2000 B (NA) 4 1597 cm <sup>3</sup> 4V 70 kW (95 PS) 10,3 88,00 mm <b>L1N</b> 05.1998 → 09.2000 B (NA) 4 1597 cm <sup>3</sup> 4V 70 kW (95 PS) 10,3 88,00 mm <b>L1Q</b> 05.1998 → 09.2000 B (NA) 4 1597 cm <sup>3</sup> 4V 70 kW (95 PS) 10,3 88,00 mm 94 916 6..				
	IN/EX [4]	12,03 x 6.08 x 36,0	G2				<b>81-18105</b>

**F**

					Reference	Item No.	
<b>30</b>	<b>76</b>						
<b>L1H</b> 94 916 6..	01.1994 → 12.1996	B (NA)	4	1597 cm <sup>3</sup> 4V	65 kW (88 PS)	10,3 88,00 mm	
	IN/EX [4]	12,03 x 6.08 x 36,0	G2			<b>81-18105</b>	
	[8]	H 28,4 x 26			1003734 1007308 1037330 1037331 1043175 6804674 6945586 938M-6500A-1D 938M-6500A-1E 938M-6500A-2E 938M-6500A-2F 938M6500A1D F5RZ 6500 BA	<b>50 007 597</b>	
<b>31</b>	<b>76</b>						
<b>FHA</b>	04.1996 → 04.2002	B (NA)	4	1388 cm <sup>3</sup> 4V	66 kW (90 PS)	10,3 76,50 mm	
<b>FHE</b>	04.1996 → 01.2002	B (NA)	4	1388 cm <sup>3</sup> 4V	66 kW (90 PS)	10,3 76,50 mm	
<b>FHF</b>	11.1997 → 10.2000	B (NA)	4	1388 cm <sup>3</sup> 4V	66 kW (90 PS)	10,3 76,50 mm	
	IN [2]	28,1 x 6 x 97,3	S - Cr -	- 45° - -	22 - III	1051773 97MM 6507 B2B	<b>105-35541</b>
	IN/EX [4]	11,05 x 6 x 39,0	G2				<b>81-18106</b>
	IN/EX [4]	11,10 x 6 x 39,0	G2				<b>81-18107</b>
	[8]	H 22,2 x 49,5				6129778 6129780	<b>50 006 477</b>
<b>32</b>	<b>76</b>						
<b>ASD</b>		B	4	1388 cm <sup>3</sup> 4V	59 kW (80 PS)	11:1 76,50 mm	
<b>ASDA</b>	07.2004 → 09.2012	B (NA)	4	1388 cm <sup>3</sup> 4V	59 kW (80 PS)	11 76,50 mm	
<b>ASDB</b>	07.2004 → 09.2012	B (NA)	4	1388 cm <sup>3</sup> 4V	59 kW (80 PS)	11 76,50 mm	
<b>FXJA</b>	11.2001 → 12.2012	B (NA)	4	1388 cm <sup>3</sup> 4V	59-62 kW (80-84 PS)	9,75 76,50 mm	
<b>FXJB</b>	11.2001 → 12.2012	B (NA)	4	1388 cm <sup>3</sup> 4V	59-62 kW (80-84 PS)	9,75 76,50 mm	
<b>SPJA</b>	10.2008 →	B (NA)	4	1388 cm <sup>3</sup> 4V	71 kW (97 PS)	76,50 mm	
<b>SPJC</b>	10.2008 →	B (NA)	4	1388 cm <sup>3</sup> 4V	71 kW (97 PS)	76,50 mm	
	IN [2]	28,1 x 6 x 99,4	S - Ni -	- 45° - -	22 -	1151997 1320926 1S4G 6507 BA 1S4G 6507 BB	<b>181115</b>
	EX [2]	24,1 x 6 x 101,4	RA - Ni -	- 45° - -	22 -	1113189 1S6G 6505 BA	<b>181107</b>
	[50]	∅ 6 mm					<b>MK-6H</b>
<b>33</b>	<b>77,24</b>						
<b>F6G</b>	07.1990 → 01.1995	B (NA)	4	1392 cm <sup>3</sup> 2V	52 kW (71 PS)	8,5 74,30 mm	
	[50]	∅ 8 mm					<b>MK-8H</b>
	IN/EX [4]	13,57 x 8 x 67,9	G1			81SM 6510 LC	<b>81-18104</b>
						1614766 81SM 6251 KE	<b>50 006 259</b> (1)

Fortsetzung nächste Seite / continued on next page / suite page suivante / continuación página próxima / Продолжение на следующей странице

					Reference	Item No.
(1)	Schalenhartguss/chilled cast iron/pièce moulée trempée en surface/fundición en coquilla/Отливка с отбелсным поверхностным слоем					
[8]	H 22,2 x 49,5				6129778 6129780	<b>50 006 477</b>
<b>34</b>	<b>77,25</b>					
<b>FUAA</b>	10.1985 → 10.1990	B (NA)	4	1392 cm <sup>3</sup>	2V 51-55 kW (69-75 PS)	9,5 74,30 mm
[50]	∅ 8 mm					<b>MK-8H</b>
[4]	13,57 x 8 x 67,9	G1			81SM 6510 LC	<b>81-18104</b>
[8]	H 22,2 x 49,5				6129778 6129780	<b>50 006 477</b>
<b>35</b>	<b>77,25</b>					
<b>F4A</b>	03.1989 → 12.1995	B (NA)	4	1392 cm <sup>3</sup>	2V 54 kW (73 PS)	8,5 74,30 mm
<b>F4B</b>	09.1990 → 08.2000	B (NA)	4	1392 cm <sup>3</sup>	2V 54-55 kW (73-75 PS)	8,5 74,30 mm
<b>F6B</b>	01.1986 → 07.1990	B (NA)	4	1392 cm <sup>3</sup>	2V 52-54 kW (71-73 PS)	8,5 74,30 mm
<b>F6C</b>	10.1986 → 02.1989	B (NA)	4	1392 cm <sup>3</sup>	2V 52 kW (71 PS)	8,5 74,30 mm
<b>F6D</b>	01.1986 → 07.1990	B (NA)	4	1392 cm <sup>3</sup>	2V 54 kW (73 PS)	9,5 74,30 mm
<b>F6E</b>	03.1989 → 12.1995	B (NA)	4	1392 cm <sup>3</sup>	2V 52 kW (71 PS)	8,5 74,30 mm
<b>F6F</b>	07.1990 → 01.1995	B (NA)	4	1392 cm <sup>3</sup>	2V 52 kW (71 PS)	8,5 74,30 mm
<b>FUA</b>	12.1985 → 07.1990	B (NA)	4	1392 cm <sup>3</sup>	2V 55 kW (75 PS)	9,5 74,30 mm
<b>FUB</b>	10.1985 → 11.1989	B (NA)	4	1392 cm <sup>3</sup>	2V 55 kW (75 PS)	9,5 74,30 mm
<b>FUC</b>	01.1986 → 07.1990	B (NA)	4	1392 cm <sup>3</sup>	2V 54 kW (73 PS)	8,5 74,30 mm
<b>FUD</b>	02.1987 → 02.1989	B (NA)	4	1392 cm <sup>3</sup>	2V 54 kW (73 PS)	9,5 74,30 mm
<b>FUG</b>	03.1989 → 12.1995	B (NA)	4	1392 cm <sup>3</sup>	2V 54 kW (73 PS)	8,5 74,30 mm
<b>FUH</b>	07.1990 → 02.1999	B (NA)	4	1392 cm <sup>3</sup>	2V 54-55 kW (71-75 PS)	8,5 74,30 mm
<b>FUJ</b>	03.1989 → 12.1995	B (NA)	4	1392 cm <sup>3</sup>	2V 54 kW (73 PS)	8,5 74,30 mm
[50]	∅ 8 mm					<b>MK-8H</b>
[4]	13,57 x 8 x 67,9	G1			81SM 6510 LC	<b>81-18104</b>
					1614766 81SM 6251 KE	<b>50 006 259</b> (1)
(1)	Schalenhartguss/chilled cast iron/pièce moulée trempée en surface/fundición en coquilla/Отливка с отбелсным поверхностным слоем					
[8]	H 22,2 x 49,5				6129778 6129780	<b>50 006 477</b>
<b>36</b>	<b>77,25</b>					
<b>F6A</b>	09.1986 → 09.1989	B (NA)	4	1393 cm <sup>3</sup>	2V 52-54 kW (71-73 PS)	8,5 74,30 mm
[50]	∅ 8 mm					<b>MK-8H</b>
[4]	10,60 x 5,5 x 34,0	G2				<b>81-4222</b> <sup>NEW</sup>
[4]	13,57 x 8 x 67,9	G1			81SM 6510 LC	<b>81-18104</b>
					1614766 81SM 6251 KE	<b>50 006 259</b> (1)
(1)	Schalenhartguss/chilled cast iron/pièce moulée trempée en surface/fundición en coquilla/Отливка с отбелсным поверхностным слоем					
[8]	H 22,2 x 49,5				6129778 6129780	<b>50 006 477</b>

**F**

					Reference	Item No.	
<b>37</b>	<b>77,25</b>						
FU		B	(NA)	4	1392 cm <sup>3</sup> 2V	55 kW (75 PS) 9,5:1 74,30 mm	
FUF	11.1992 → 12.1996	B	(NA)	4	1392 cm <sup>3</sup> 2V	55 kW (75 PS) 9,5 74,30 mm	
	[50]	∅ 8 mm				<b>MK-8H</b>	
	IN/EX [4]	13,57 x 8 x 67,9	G1		81SM 6510 LC	<b>81-18104</b>	
<b>38</b>	<b>79</b>						
JAC	01.1970 → 07.1979	B	(NA)	4	1297 cm <sup>3</sup> 2V	40-43 kW (55-58 PS) 9,5 66,00 mm	
					6062844 78HM 6250 AA	<b>50 006 260</b>	
<b>39</b>	<b>79</b>						
JCT	08.1982 → 12.1986	B	(NA)	4	1294 cm <sup>3</sup> 2V	44 kW (60 PS) 66,00 mm	
	EX [4]				6062845 78HM6564AA	<b>50 007 624</b>	
<b>40</b>	<b>79</b>						
FYDA	10.1998 → 06.2007	B	(NA)	4	1596 cm <sup>3</sup> 4V	74-75 kW (100-102 PS) 11 81,40 mm	
FYDB	10.1998 → 03.2005	B	(NA)	4	1596 cm <sup>3</sup> 4V	74 kW (100 PS) 11 81,40 mm	
FYDC	10.1998 → 12.2011	B	(NA)	4	1596 cm <sup>3</sup> 4V	74 kW (100 PS) 11 81,40 mm	
FYDD	10.1998 → 03.2005	B	(NA)	4	1596 cm <sup>3</sup> 4V	74 kW (100 PS) 11 81,40 mm	
FYDG		B		4	1596 cm <sup>3</sup> 4V	74 kW (101 PS) 11:1 81,40 mm	
FYDH	10.1998 → 11.2004	B	(NA)	4	1596 cm <sup>3</sup> 4V	74-75 kW (100-102 PS) 11 81,40 mm	
FYJA	11.2001 → 11.2009	B	(NA)	4	1596 cm <sup>3</sup> 4V	74 kW (100 PS) 9,75 81,40 mm	
FYJB	11.2001 → 11.2009	B	(NA)	4	1596 cm <sup>3</sup> 4V	74 kW (100 PS) 9,75 81,40 mm	
	IN [2]	30,1 x 6 x 97,0	S - Cr -	- 45° -	- 22 - III	1072048 98MM 6507 C2B	<b>181009</b>
	IN [2]	30,1 x 6 x 99,0	S - Ni -	- 45° -	- 22 -	1122364 1320927 1S4G 6507 CA 1S4G 6507 CB	<b>181106</b>
	EX [2]	24,1 x 6 x 101,4	RA - Ni -	- 45° -	- 22 -	1113189	<b>181107</b>
	EX [2]	24,1 x 6 x 99,4	RA - Ni -	- 45° -	- 22 - III	1S6G 6505 BA 1069529 1101934 XS6G 6505 B2A	<b>181008</b>
	[50]	∅ 6 mm					<b>MK-6H</b>
	IN/EX [4]	11,04 x 6.01 x 40,5	G1				<b>81-71003</b>
<b>41</b>	<b>79</b>						
L1T	02.2000 → 01.2002	B	(NA)	4	1596 cm <sup>3</sup> 4V	76 kW (103 PS) 11 81,40 mm	
L1V	02.1999 → 09.2002	B	(NA)	4	1596 cm <sup>3</sup> 4V	70-76 kW (95-103 PS) 11 81,40 mm	
	IN/EX [4]	12,03 x 6.08 x 36,0	G2				<b>81-18105</b>

					Reference	Item No.		
<b>42</b>		<b>79</b>						
FYJC	08.2002 → 11.2009	B (NA)	4	1596 cm <sup>3</sup>	4V	74 kW (100 PS)	11	81,40 mm
HWDA	10.2003 → 09.2012	B (NA)	4	1596 cm <sup>3</sup>	4V	74 kW (100 PS)	11	81,40 mm
HWDB	10.2003 → 09.2012	B (NA)	4	1596 cm <sup>3</sup>	4V	74 kW (100 PS)	11	81,40 mm
HXDA	07.2004 → 09.2012	B (NA)	4	1596 cm <sup>3</sup>	4V	85 kW (115 PS)	11	81,40 mm
HXDB	07.2004 → 09.2012	B (NA)	4	1596 cm <sup>3</sup>	4V	85 kW (115 PS)	11:1	81,40 mm
HXJA	06.2008 →	B (NA)	4	1596 cm <sup>3</sup>	4V	88-89 kW (120-121 PS)	11	81,40 mm
HXJB	06.2008 →	B (NA)	4	1596 cm <sup>3</sup>	4V	88-89 kW (120-121 PS)	11	81,40 mm
HXJD	08.2012 →	B (A)	4	1596 cm <sup>3</sup>	4V	90 kW (122 PS)	11	81,40 mm
PNBA	03.2007 → 01.2015	B (NA)	4	1596 cm <sup>3</sup>	4V	92 kW (125 PS)	11	81,40 mm
RHBA	03.2007 → 01.2015	B (NA)	4	1596 cm <sup>3</sup>	4V	81 kW (110 PS)	11	81,40 mm
SHDA	10.2003 → 09.2012	B (NA)	4	1596 cm <sup>3</sup>	4V	74 kW (101 PS)	11:1	81,40 mm
SHDB	10.2003 → 09.2012	B (NA)	4	1596 cm <sup>3</sup>	4V	74 kW (101 PS)	11:1	81,40 mm
SHDC	10.2003 → 09.2012	B (NA)	4	1596 cm <sup>3</sup>	4V	74 kW (101 PS)	11:1	81,40 mm
	IN [2]	30,1 x 6 x 99,0	S - Ni -	- 45° -	-	22 -	1122364 1320927 1S4G 6507 CA 1S4G 6507 CB	<b>181106</b>
	EX [2]	24,1 x 6 x 101,4	RA - Ni -	- 45° -	-	22 -	1113189 1S6G 6505 BA	<b>181107</b>
	[50]	∅ 6 mm						<b>MK-6H</b>
	IN/EX [4]	11,04 x 6.01 x 40,5	G1					<b>81-71003</b>
<b>43</b>		<b>79</b>						
IQDB	07.2010 →	B (NA)	4	1596 cm <sup>3</sup>	4V	77 kW (105 PS)	11	81,40 mm
IQJA	09.2012 →	B (NA)	4	1596 cm <sup>3</sup>	4V	77 kW (105 PS)	11	81,40 mm
JQDA	07.2010 →	B (A)	4	1596 cm <sup>3</sup>	4V	110 kW (150 PS)	10	81,40 mm
JQDB	07.2010 →	B (A)	4	1596 cm <sup>3</sup>	4V	110 kW (150 PS)	10	81,40 mm
JQMA	03.2013 →	B (A)	4	1596 cm <sup>3</sup>	4V	110 kW (150 PS)	10	81,40 mm
JQMB	03.2013 →	B (A)	4	1596 cm <sup>3</sup>	4V	110 kW (150 PS)	10	81,40 mm
JTBA	11.2010 → 01.2015	B (A)	4	1596 cm <sup>3</sup>	4V	118 kW (160 PS)		81,40 mm
JTBB	11.2010 → 01.2015	B (A)	4	1596 cm <sup>3</sup>	4V	118 kW (160 PS)		81,40 mm
JTDA	07.2010 →	B (A)	4	1596 cm <sup>3</sup>	4V	134 kW (182 PS)	10	81,40 mm
JTDB	07.2010 →	B (A)	4	1596 cm <sup>3</sup>	4V	134 kW (182 PS)	10	81,40 mm
JTJA Euro 5	03.2013 →	B (A)	4	1596 cm <sup>3</sup>	4V	134 kW (182 PS)	10	81,40 mm
JTJB	03.2013 →	B (A)	4	1596 cm <sup>3</sup>	4V	134 kW (182 PS)	10	81,40 mm
JTMA	10.2012 →	B (A)	4	1596 cm <sup>3</sup>	4V	130-134 kW (179-182 PS)	10	81,40 mm
JTWA	11.2010 → 06.2015	B (A)	4	1596 cm <sup>3</sup>	4V	118 kW (160 PS)	10	81,40 mm
JTWB	11.2010 → 06.2015	B (A)	4	1596 cm <sup>3</sup>	4V	118 kW (160 PS)	10	81,40 mm
M8DA	09.2014 →	B (A)	4	1498 cm <sup>3</sup>	4V	110 kW (150 PS)	10	76,40 mm
M8DB	09.2014 →	B (A)	4	1498 cm <sup>3</sup>	4V	110 kW (150 PS)	10	76,40 mm
M8MA	09.2014 →	B (A)	4	1499 cm <sup>3</sup>	4V	110 kW (150 PS)	10	76,40 mm
M9DA	09.2014 →	B (A)	4	1498 cm <sup>3</sup>	4V	132-134 kW (179-182 PS)	10	76,40 mm
M9DB	09.2014 →	B (A)	4	1498 cm <sup>3</sup>	4V	132-134 kW (179-182 PS)	10	76,40 mm
UNCA Euro 6	09.2014 →	B (LA)	4	1499 cm <sup>3</sup>	4V	118 kW (160 PS)	10	76,40 mm
UNCB Euro 6	09.2014 →	B (LA)	4	1499 cm <sup>3</sup>	4V	118 kW (160 PS)	10	76,40 mm
UNCE Euro 6	09.2014 →	B (LA)	4	1499 cm <sup>3</sup>	4V	118 kW (160 PS)	10	76,40 mm
UNCF Euro 6	09.2014 →	B (LA)	4	1499 cm <sup>3</sup>	4V	118 kW (160 PS)	10,1	76,40 mm
40 883 6..								
	IN/EX [1]	9,53 x 5 x 36,0	B1					<b>81-18113</b>
<b>44</b>		<b>79,5</b>						
1Z	03.1995 → 05.2006	D (LA)	4	1896 cm <sup>3</sup>	2V	66 kW (90 PS)	19,5	95,50 mm
AFN	08.1997 → 04.2000	D (LA)	4	1896 cm <sup>3</sup>	2V	81 kW (110 PS)	19,5	95,50 mm
AHU	03.1995 → 05.2006	D (LA)	4	1896 cm <sup>3</sup>	2V	66 kW (90 PS)	19,5	95,50 mm
94 427 7.., 94 428 7..								
Fortsetzung nächste Seite / continued on next page / suite page suivante / continuación página próxima / Продолжение на следующей странице								

**F**



					Reference	Item No.
	IN [2] 36,0 x 7 x 96,9 EX [2] 36,0 x 8 x 96,9	S - - RA/S- -	- 45° - - - 45° - VS -	22 - III 22 - III	028 109 601 D 028109601H 1669766	<b>39486</b> <b>39423</b> (1)
	IN [2] 36,1 x 8 x 96,9 EX [2] 31,6 x 7 x 96,9 EX [2] 31,6 x 8 x 96,9	S - - RA/S- - RA/S- -	- 45° - - - 45° - - - 45° - -	22 - III 22 - III 22 - III	1669772	<b>331141</b> (2) <b>331143</b> <b>331142</b>
	(1) OES specification (2) IAM specification					
	[50] Ø 7 mm [50] Ø 8 mm					<b>MK-7H</b> <b>MK-8H</b>
	IN/EX [4] 12,06/15 x 8 x 36,5 IN/EX [4] 12,08/15 x 7 x 36,5 IN/EX [4] 12,13/15 x 8 x 36,5 IN/EX [4] 12,20/15 x 8 x 36,5 IN/EX [4] 12,25/15 x 7 x 36,5	B1 B1 B1 B1 B1			1005252	<b>81-3310</b> <b>81-33103</b> <b>81-3312</b> <b>81-3311</b> <b>81-33104</b>
	(3) Schalenhartguss/chilled cast iron/pièce moulée trempée en surface/fundición en coquilla/Отливка с отбелсным поверхностным слоем					<b>50 006 205</b> (3)
	[8] H 35 x 26 x 26				1 639 187 1 649 127 1 669 765	<b>50 006 460</b>

## 45 79,5

**AVG** 08.1997 → 04.2000 D (A) 4 1896 cm<sup>3</sup> 2V 81 kW (110 PS) 19,5 95,50 mm  
94 427 7..., 94 428 7...

	IN [2] 36,0 x 7 x 96,9 EX [2] 31,6 x 7 x 96,9	S - - RA/S- -	- 45° - - - 45° - -	22 - III 22 - III	028 109 601 D	<b>39486</b> <b>331143</b>
	[50] Ø 7 mm					<b>MK-7H</b>
	IN/EX [4] 12,08/15 x 7 x 36,5 IN/EX [4] 12,25/15 x 7 x 36,5	B1 B1				<b>81-33103</b> <b>81-33104</b>
	(1) Schalenhartguss/chilled cast iron/pièce moulée trempée en surface/fundición en coquilla/Отливка с отбелсным поверхностным слоем					<b>50 006 205</b> (1)
	[8] H 35 x 26 x 26					<b>50 006 417</b>

## 46 79,5

**ANU** 09.1999 → 05.2006 D (LA) 4 1896 cm<sup>3</sup> 2V 66 kW (90 PS) 18 95,50 mm  
**ASZ** 02.2003 → 05.2006 D (LA) 4 1896 cm<sup>3</sup> 2V 96 kW (130 PS) 19:1 95,50 mm  
**AUY** 04.2000 → 05.2006 D (LA) 4 1896 cm<sup>3</sup> 2V 85 kW (115 PS) 18 95,50 mm  
99 470 6..., 99 843 6..., 99 850 6..., 99 851 6...

	IN [2] 35,9 x 7 x 89,9 EX [2] 31,5 x 7 x 90,0	S - - A/S - -	- 45° - - - 45° - VS -	22 - III 22 - III	038109601B 038109611B	<b>331033</b> <b>331034</b>
	[50] Ø 7 mm					<b>MK-7H</b>
	IN/EX [4] 12,08/15 x 7 x 36,5 IN/EX [4] 12,08/15 x 7 x 38,0 IN/EX [4] 12,25/15 x 7 x 36,5	B1 B1 B1				<b>81-33103</b> <b>81-33100</b> <b>81-33104</b>

Fortsetzung nächste Seite / continued on next page / suite page suivante / continuación página próxima / Продолжение на следующей странице

					Reference	Item No.
	(1) Alloy Steel SAE 8620 / (ST)				1100669 XM21-6251-AA	50 006 304 (1)
	[8] H 35 x 26 x 26				1100677 1426035 XM21 650 BA	50 006 418
	- - G - S -	- SB - -				50 003 131
	CAM - V - G - S -	- SB - -	 40 Nm 60 Nm - 90° + 60 Nm 90° 90° ready-to-install			50 003 431 (2)
(2)	Nockenwelle/camshaft/arbre à cames/árbol de levas/кулачковый вал OE# 038 109 101R					

F

**47** **79,5**

BTB	05.2005 → 05.2006	D (LA)	4	1896 cm <sup>3</sup>	2V	110 kW	(150 PS)	19:1	95,50 mm
	IN [2] EX [2]	35,9 x 7 x 89,9 31,5 x 7 x 90,0	S - - A/S - -	- 45° - - - 45° - VS -	22 - III 22 - III	038109601B 038109611B			331033 331034
	[50]	Ø 7 mm							MK-7H
	IN/EX [4] IN/EX [4] IN/EX [4]	12,08/15 x 7 x 36,5 12,08/15 x 7 x 38,0 12,25/15 x 7 x 36,5	B1 B1 B1						81-33103 81-33100 81-33104
	[8]	H 35 x 26 x 26				1100677 1426035 XM21 650 BA			50 006 418
	- - G - S -	- SB - -							50 003 131
	CAM - V - G - S -	- SB - -	 40 Nm 60 Nm - 90° + 60 Nm 90° 90° ready-to-install					50 003 431 (1)	
(1)	Nockenwelle/camshaft/arbre à cames/árbol de levas/кулачковый вал OE# 038 109 101R								

**48** **79,96**

LJF	07.1990 → 08.1993	B (NA)	4	1598 cm <sup>3</sup>	2V	77 kW	(105 PS)	9,75	79,52 mm
LNA	11.1984 → 12.1985	B (LA)	4	1597 cm <sup>3</sup>	2V	97 kW	(132 PS)	8,2	79,52 mm
LNB	01.1986 → 07.1990	B (LA)	4	1597 cm <sup>3</sup>	2V	97 kW	(132 PS)	8,2	79,52 mm
	[50]	Ø 8 mm							MK-8H
	IN/EX [4]	13,57 x 8 x 67,9	G1			81SM 6510 LC			81-18104
	[8]	H 22,2 x 49,5				6129778 6129780			50 006 477

**49** **79,96**

HL 1.3 (51 kW)	B	4	1296 cm <sup>3</sup>	2V	51 kW	(69 PS)	9,5:1	64,52 mm
HL 1.6 CFI	B	4	1597 cm <sup>3</sup>	2V	59 kW	(80 PS)	9:1	79,52 mm
HL 16 T	B (A)	4	1597 cm <sup>3</sup>	2V	97 kW	(132 PS)	8,2:1	79,52 mm

Fortsetzung nächste Seite / continued on next page / suite page suivante / continuación página próxima / Продолжение на следующей странице

					Reference	Item No.
	IN/EX [4]	13,57 x 8 x 67,9	G1		81SM 6510 LC	<b>81-18104</b>

## 50

JPA	09.1980 → 07.1988	B (NA)	4	1296 cm <sup>3</sup>	2V	51 kW (69 PS)	9,5	64,50 mm
JPC	09.1983 → 09.1989	B (NA)	4	1297 cm <sup>3</sup>	2V	51 kW (69 PS)	9,5	64,50 mm
LP1	09.1980 → 03.1986	B (NA)	4	1597 cm <sup>3</sup>	2V	52-58 kW (71-79 PS)	9,5	79,50 mm
LP2	01.1986 → 07.1990	B (NA)	4	1597 cm <sup>3</sup>	2V	58 kW (79 PS)	9,5	79,50 mm
LP3	01.1985 → 11.1989	B (NA)	4	1597 cm <sup>3</sup>	2V	58 kW (79 PS)	9,5	79,50 mm
LPA	09.1980 → 12.1987	B (NA)	4	1597 cm <sup>3</sup>	2V	58 kW (79 PS)	9,5	79,50 mm
LUA	09.1980 → 10.1982	B (NA)	4	1597 cm <sup>3</sup>	2V	71 kW (96 PS)	9,5	79,50 mm
LUAE	05.1982 → 12.1985	B (NA)	4	1597 cm <sup>3</sup>	2V	85 kW (115 PS)	9,5	79,50 mm
LUB	04.1984 → 02.1989	B (NA)	4	1597 cm <sup>3</sup>	2V	70-71 kW (95-97 PS)	9,5	79,50 mm
LUC	12.1985 → 07.1990	B (NA)	4	1597 cm <sup>3</sup>	2V	60-66 kW (81-90 PS)	9,5	79,50 mm
LUG	03.1986 → 07.1990	B (NA)	4	1597 cm <sup>3</sup>	2V	65-66 kW (88-90 PS)	8,5	79,50 mm
LUK	07.1990 → 12.1992	B (NA)	4	1598 cm <sup>3</sup>	2V	65-66 kW (88-90 PS)	9,5	79,50 mm

	[50]	Ø 8 mm						<b>MK-8H</b>
	IN/EX [4]	13,57 x 8 x 67,9	G1			81SM 6510 LC		<b>81-18104</b>
						1614766 81SM 6251 KE		<b>50 006 259</b> (1)
								(1) Schalenhartguss/chilled cast iron/pièce moulée trempée en surface/fundición en coquilla/Отливка с отбеленным поверхностным слоем
	[8]	H 22,2 x 49,5				6129778 6129780		<b>50 006 477</b>

## 51

L4B	07.1985 → 07.1990	B (NA)	4	1598 cm <sup>3</sup>	2V	66 kW (90 PS)	8,5	79,50 mm
LHA	03.1990 → 10.1992	B (A)	4	1598 cm <sup>3</sup>	2V	96-98 kW (131-133 PS)	8,2	79,50 mm
LJB	02.1986 → 07.1990	B (NA)	4	1597 cm <sup>3</sup>	2V	75 kW (102 PS)	9,75	79,50 mm
LJC	03.1989 → 01.1994	B (NA)	4	1597 cm <sup>3</sup>	2V	81 kW (110 PS)	9,75	79,50 mm
LJD	03.1989 → 03.1993	B (NA)	4	1598 cm <sup>3</sup>	2V	76 kW (103 PS)	9,75	79,50 mm
LR1	10.1982 → 03.1986	B (NA)	4	1597 cm <sup>3</sup>	2V	77 kW (105 PS)	9,5	79,50 mm
LR2	01.1986 → 07.1990	B (NA)	4	1597 cm <sup>3</sup>	2V	77 kW (105 PS)	9,5	79,50 mm
LRA	10.1982 → 03.1986	B (NA)	4	1597 cm <sup>3</sup>	2V	77 kW (105 PS)	9,5	79,50 mm
LRB	01.1986 → 07.1990	B (NA)	4	1597 cm <sup>3</sup>	2V	77 kW (105 PS)	9,5	79,50 mm
LUD	03.1984 → 02.1989	B (NA)	4	1597 cm <sup>3</sup>	2V	70 kW (95 PS)	9,5	79,50 mm

	[50]	Ø 8 mm						<b>MK-8H</b>
	IN/EX [4]	13,57 x 8 x 67,9	G1			81SM 6510 LC		<b>81-18104</b>
	[8]	H 22,2 x 49,5				6129778 6129780		<b>50 006 477</b>

## 52

R2C	05.1988 → 02.1993	B (NA)	4	1769 cm <sup>3</sup>	2V	64 kW (87 PS)	9,3	88,00 mm
R6A	05.1988 → 02.1993	B (NA)	4	1769 cm <sup>3</sup>	2V	64-66 kW (87-90 PS)	9,3	88,00 mm

93 754 6..

	[50]	Ø 8 mm						<b>MK-8H</b>
	IN/EX [4]	13,57 x 8 x 67,9	G1			81SM 6510 LC		<b>81-18104</b>

Fortsetzung nächste Seite / continued on next page / suite page suivante / continuación página próxima / Продолжение на следующей странице

					Reference	Item No.		
	EX [4]				6062845 78HM6564AA	50 007 624		
<b>53</b>								
<b>L6B</b>	10.1989 → 02.1993	B (NA)	4	1598 cm <sup>3</sup>	2V	59 kW (80 PS) 9,1	79,50 mm	
	[50]	∅ 8 mm					MK-8H	
	IN/EX [4]	13,57 x 8 x 67,9	G1			81SM 6510 LC	81-18104	
	[8]	H 22,2 x 49,5				6129778 6129780	50 006 477	
	EX [4]					6062845 78HM6564AA	50 007 624	
<b>54</b>								
<b>LUJ</b>	07.1990 → 12.1992	B (NA)	4	1598 cm <sup>3</sup>	2V	65-66 kW (88-90 PS) 9,5	79,50 mm	
	EX [2]	24,5 x 6 x 96,6	A/S - Cr -	- 45° -	-	1 - III	1023591 7314594 7314599 928M 6505 C2A 948M 6505 A2A	105-35514
	IN/EX [4]	11,05 x 6 x 39,0	G2				81-18106	
	IN/EX [4]	11,10 x 6 x 39,0	G2				81-18107	
						1614766 81SM 6251 KE	50 006 259 (1)	
		(1) Schalenhartguss/chilled cast iron/pièce moulée trempée en surface/fundición en coquilla/Отливка с отбеленным поверхностным слоем						
	[8]	H 22,2 x 49,5				6129778 6129780	50 006 477	
<b>55</b>								
<b>LJE</b>		B (NA)	4	1598 cm <sup>3</sup>	2V	79 kW (108 PS) 9,75:1	79,50 mm	
	[50]	∅ 8 mm					MK-8H	
	IN/EX [4]	13,57 x 8 x 67,9	G1			81SM 6510 LC	81-18104	
<b>56</b>								
<b>LTA</b>	02.1984 → 07.1990	D (NA)	4	1608 cm <sup>3</sup>	2V	40 kW (54 PS) 21,5	80,00 mm	
<b>LTB</b>	09.1983 → 09.1989	D (NA)	4	1608 cm <sup>3</sup>	2V	40 kW (54 PS) 21,5	80,00 mm	
<b>LTC</b>	12.1985 → 01.1989	D (NA)	4	1608 cm <sup>3</sup>	2V	40 kW (54 PS) 21,5	80,00 mm	
	IN [2]	37,0 x 7 x 108,4	S - -	- 45° -	-	9 -	537627	
	EX [2]	31,6 x 7 x 108,2	A - Cr -	- 45° -	-	9 -	537628	
	[50]	∅ 7 mm					KK-7H	
	IN/EX [4]	12,76 x 7.91 x 38,0	G1				81-5801	

**F**

					Reference	Item No.		
<b>57</b>	<b>80,6</b>							
RDA	02.1992 → 08.1998	B (NA)	4	1796 cm <sup>3</sup>	4V	77 kW (105 PS) 10	88,00 mm	
RDB	02.1992 → 12.1995	B (NA)	4	1796 cm <sup>3</sup>	4V	77 kW (105 PS) 10	88,00 mm	
RKC	01.1995 → 02.1999	B (NA)	4	1796 cm <sup>3</sup>	4V	85 kW (115 PS) 9,8	88,00 mm	
RKF	08.1996 → 09.2000	B (NA)	4	1796 cm <sup>3</sup>	4V	85 kW (115 PS) 10	88,00 mm	
RKH	08.1996 → 09.2000	B (NA)	4	1796 cm <sup>3</sup>	4V	85 kW (115 PS) 10	88,00 mm	
RKJ	08.1996 → 09.2000	B (NA)	4	1796 cm <sup>3</sup>	4V	85 kW (115 PS) 10	88,00 mm	
RQB	01.1992 → 08.2000	B (NA)	4	1796 cm <sup>3</sup>	4V	96 kW (130 PS) 10	88,00 mm	
RQC	02.1992 → 12.1995	B (NA)	4	1796 cm <sup>3</sup>	4V	96 kW (130 PS) 10	88,00 mm	
	IN [2]	32,0 x 6 x 97,0	S - Cr -	- 45° -	-	22 - III	1041838 928M 6507 F2A	<b>105-35551</b>
	EX [2]	28,0 x 6 x 96,7	A/S - Cr -	- 45° -	-	22 - III	1033899 948M 6505 D2A	<b>105-35552</b>
	IN/EX [4]	12,03 x 6.08 x 36,0	G2					<b>81-18105</b>
	[8]	H 28,4 x 26					1003734 1007308 1037330 1037331 1043175 6804674 6945586 938M-6500A-1D 938M-6500A-1E 938M-6500A-2E 938M-6500A-2F 938M6500A1D F5RZ 6500 BA	<b>50 007 597</b>
<b>58</b>	<b>80,6</b>							
RKA	02.1993 → 02.2002	B (NA)	4	1796 cm <sup>3</sup>	4V	85 kW (115 PS) 10	88,00 mm	
RKB	01.1994 → 09.2000	B (NA)	4	1796 cm <sup>3</sup>	4V	82-85 kW (111-116 PS) 10	88,00 mm	
RKK	08.1996 → 09.2000	B (NA)	4	1796 cm <sup>3</sup>	4V	85 kW (115 PS) 10	88,00 mm	
	EX [2]	28,0 x 6 x 96,7	RA/S- Cr -	- 45° -	-	1 - III	6640542 928M 6505 D2A	<b>18391</b>
	IN/EX [4]	12,03 x 6.08 x 36,0	G2					<b>81-18105</b>
<b>59</b>	<b>80,6</b>							
EYDB	10.1998 → 03.2005	B (NA)	4	1796 cm <sup>3</sup>	4V	85 kW (115 PS) 10	88,00 mm	
EYDC	10.1998 → 03.2005	B (NA)	4	1796 cm <sup>3</sup>	4V	85 kW (115 PS) 10	88,00 mm	
EYPA	06.2002 → 12.2013	B (NA)	4	1796 cm <sup>3</sup>	4V	85 kW (116 PS) 10:1	88,00 mm	
	IN [2]	33,0 x 6 x 98,0	S - -	- 45° -	-	22 - III	1053845 XS7E 6507 D2A	<b>181012</b>
	EX [2]	28,0 x 6 x 97,6	A/S - Cr -	- 45° -	-	22 - III	1053843 1066045 1124514 XS7E 6505 D2D	<b>181021</b>
	IN/EX [4]	12,03 x 6.08 x 36,0	G2					<b>81-18105</b>
<b>60</b>	<b>80,98</b>							
L3E	08.1981 → 08.1983	B (NA)	4	1598 cm <sup>3</sup>	2V	62-71 kW (84-97 PS) 9	77,60 mm	
	[50]	∅ 8 mm						<b>MK-8H</b>
	IN/EX [4]	13,57 x 8 x 67,9	G1				81SM 6510 LC	<b>81-18104</b>





KOLBENSCHMIDT

TRW  
EngineComponents

FORD

					Reference	Item No.		
<b>61</b>		<b>81</b>						
J2	06.1968 → 08.1980	B (NA)	4	1298 cm <sup>3</sup>	2V	38-47 kW (52-64 PS) 9,2	63,00 mm	
LC	12.1974 → 08.1980	B (NA)	4	1598 cm <sup>3</sup>	2V	53-62 kW (72-84 PS) 9,5	77,60 mm	
	EX [4]					6062845 78HM6564AA	<b>50 007 624</b>	
<b>62</b>		<b>81</b>						
J1E	02.1974 → 06.1985	B (NA)	4	1298 cm <sup>3</sup>	2V	40 kW (54 PS) 9,2	63,00 mm	
J1F	09.1973 → 08.1980	B (NA)	4	1298 cm <sup>3</sup>	2V	40 kW (54 PS) 9,2	63,00 mm	
						1614766 81SM 6251 KE	<b>50 006 259</b> (1)	
	(1)	Schalenhartguss/chilled cast iron/pièce moulée trempée en surface/fundición en coquilla/Отливка с отбеленным поверхностным слоем						
	EX [4]					6062845 78HM6564AA	<b>50 007 624</b>	
<b>63</b>		<b>81</b>						
AMY	11.1995 → 04.2000	B (NA)	6	2792 cm <sup>3</sup>	2V	128 kW (174 PS) 10	90,30 mm	
91 033 6..								
	IN [2]	39,0 x 7 x 106,0	S - -	- 45° - -	22 - III		<b>331040</b>	
	EX [2]	34,2 x 7 x 106,9	RA/S- -	- 45° - VS -	22 - III		<b>331109</b>	
	[50]	∅ 7 mm					<b>MK-7H</b>	
	IN/EX [4]	12,08/15 x 7 x 36,5	B1				<b>81-33103</b>	
	IN/EX [4]	12,08/15 x 7 x 38,0	B1				<b>81-33100</b>	
	IN/EX [4]	12,25/15 x 7 x 36,5	B1				<b>81-33104</b>	
	[8]	H 35 x 26 x 26				1 639 187 1 649 127 1 669 765	<b>50 006 460</b>	
<b>64</b>		<b>81</b>						
AAA	11.1995 → 07.2000	B (NA)	6	2792 cm <sup>3</sup>	2V	128 kW (174 PS) 10	90,30 mm	
91 033 6..								
	IN [2]	39,0 x 7 x 106,0	S - -	- 45° - -	22 - III		<b>331040</b>	
	EX [2]	34,2 x 7 x 106,9	RA/S- -	- 45° - VS -	22 - III		<b>331109</b>	
	[50]	∅ 7 mm					<b>MK-7H</b>	
	IN/EX [4]	12,08/15 x 7 x 38,0	B1				<b>81-33100</b>	
	[8]	H 35 x 26 x 26				1 639 187 1 649 127 1 669 765	<b>50 006 460</b>	
<b>65</b>		<b>81</b>						
AYL	04.2000 → 05.2006	B (NA)	6	2792 cm <sup>3</sup>	4V	150 kW (204 PS) 10,5	90,30 mm	
	IN [2]	31,0 x 6 x 102,1	S - -	- 45° - -	22 - III		<b>331041</b>	
	IN [2]	31,0 x 6 x 136,1	S - -	- 45° - -	22 - III		<b>331135</b>	
	EX [2]	27,0 x 6 x 102,5	RA/S- Cr -	- 45° - VS -	22 - III		<b>331136</b>	
	EX [2]	27,0 x 6 x 136,4	A/S - -	- 45° - VS -	22 - III		<b>331042</b>	
	[50]	∅ 6 mm					<b>MK-6H</b>	
Fortsetzung nächste Seite / continued on next page / suite page suivante / continuación página próxima / Продолжение на следующей странице								

					Reference	Item No.	
[8]	H 12 x 34,5					<b>50 006 491</b>	
<b>66</b>	<b>81,3</b>						
LCS	08.1982 → 12.1986	B (NA)	4	1593 cm <sup>3</sup>	2V 55 kW (75 PS)	9,5 77,00 mm	
LCT	08.1982 → 12.1986	B (NA)	4	1593 cm <sup>3</sup>	2V 55 kW (75 PS)	9,5 77,00 mm	
LSD	08.1982 → 12.1986	B (NA)	4	1597 cm <sup>3</sup>	2V 55-58 kW (75-79 PS)	9,5 76,90 mm	
LSDA	10.1982 → 02.1987	B (NA)	4	1597 cm <sup>3</sup>	2V 51 kW (69 PS)	9,5 76,90 mm	
LSE	01.1987 → 02.1993	B (NA)	4	1597 cm <sup>3</sup>	2V 55 kW (75 PS)	9,5 76,90 mm	
LSF	01.1988 → 02.1993	B (NA)	4	1597 cm <sup>3</sup>	2V 53 kW (72 PS)	9,5 76,90 mm	
EX [4]					6062845 78HM6564AA	<b>50 007 624</b>	
<b>67</b>	<b>81,6</b>						
LCBB	08.1998 → 12.2001	B (NA)	6	2495 cm <sup>3</sup>	4V 125 kW (170 PS)	9,2 79,50 mm	
LCBC	08.1998 → 12.2001	B (NA)	6	2495 cm <sup>3</sup>	4V 125 kW (170 PS)	9,2 79,50 mm	
LCBD	06.2000 → 03.2007	B (NA)	6	2495 cm <sup>3</sup>	4V 125 kW (170 PS)	9,8 79,50 mm	
LCBE	08.1998 → 12.2001	B (NA)	6	2495 cm <sup>3</sup>	4V 125 kW (170 PS)	9,2 79,50 mm	
IN [2]	31,0 x 6 x 104,3	S - Cr -		- 45° -	- 22 - III	1369828 6M5G 6507 AA	<b>471206</b>
IN [2]	32,0 x 6 x 104,3	S - Ni -		- 45° -	- 22 - III		<b>471207</b>
EX [2]	27,0 x 6 x 103,3	RA/S- Ni -		- 45° - VS -	- 22 - III	1369831 6M5G 6505 AA	<b>471209</b>
[50]	∅ 6 mm						<b>MK-6H</b>
<b>68</b>	<b>82,4</b>						
LCBA	08.1998 → 12.2001	B (NA)	6	2544 cm <sup>3</sup>	4V 125 kW (170 PS)	9,2 79,50 mm	
IN [2]	31,0 x 6 x 104,3	S - Cr -		- 45° -	- 22 - III	1369828 6M5G 6507 AA	<b>471206</b>
IN [2]	32,0 x 6 x 104,3	S - Ni -		- 45° -	- 22 - III		<b>471207</b>
EX [2]	27,0 x 6 x 103,3	RA/S- Ni -		- 45° - VS -	- 22 - III	1369831 6M5G 6505 AA	<b>471209</b>
[50]	∅ 6 mm						<b>MK-6H</b>
<b>69</b>	<b>82,5</b>						
RFA	10.1987 → 02.1993	D (A)	4	1753 cm <sup>3</sup>	2V 55-57 kW (75-78 PS)	21,5 82,00 mm	
RFB	08.1988 → 02.1993	D (A)	4	1753 cm <sup>3</sup>	2V 55-57 kW (75-78 PS)	21,5 82,00 mm	
RFD	03.1992 → 08.2000	D (LA)	4	1753 cm <sup>3</sup>	2V 66 kW (90 PS)	21,5 82,00 mm	
RFK	03.1992 → 08.2000	D (LA)	4	1753 cm <sup>3</sup>	2V 66 kW (90 PS)	21,5 82,00 mm	
RFL	08.1988 → 12.1995	D (A)	4	1753 cm <sup>3</sup>	2V 55-57 kW (75-78 PS)	21,5 82,00 mm	
RFM	06.1993 → 08.1996	D (LA)	4	1753 cm <sup>3</sup>	2V 65-66 kW (88-90 PS)	21,5 82,00 mm	
RFN	06.1993 → 09.2000	D (LA)	4	1753 cm <sup>3</sup>	2V 65-66 kW (88-90 PS)	21,5 82,00 mm	
RFU		D (A)	4	1753 cm <sup>3</sup>	2V 57 kW (78 PS)	21,5:1 82,00 mm	
IN [2]	36,5 x 8 x 107,1	S - Cr -		- 45° -	- 22 - III	1012773 6172851 6781621 93FF 6507 AA 93FF 6507 AF	<b>105-35529</b>
EX [2]	32,0 x 8 x 109,2	A/S - Cr -		- 45° -	- 22 - III	1078429 1352129 89FF 6505 AA	<b>18375</b>
EX [2]	32,0 x 8 x 109,2	A/S - Cr -		- 45° - VS -	- 22 - III	6172845 6172848 6172854 89FF 6505 FA	<b>18345</b>
[50]	∅ 8 mm						<b>MK-8H</b>

Fortsetzung nächste Seite / continued on next page / suite page suivante / continuación página próxima / Продолжение на следующей странице

					Reference	Item No.	
	IN/EX [4]	12,76 x 7.91 x 38,0	G1			<b>81-5801</b>	
<b>70</b>		<b>82,5</b>					
<b>RTA</b>	07.1988 → 12.1994	D (NA) 4	1753 cm <sup>3</sup>	2V	44 kW (60 PS)	21,5 82,00 mm	
<b>RTB</b>	07.1988 → 07.1990	D (NA) 4	1753 cm <sup>3</sup>	2V	44 kW (60 PS)	21,5 82,00 mm	
<b>RTC</b>	03.1989 → 02.1996	D (NA) 4	1753 cm <sup>3</sup>	2V	43-44 kW (58-60 PS)	21,5 82,00 mm	
<b>RTD</b>	03.1989 → 02.1996	D (NA) 4	1753 cm <sup>3</sup>	2V	43-44 kW (58-60 PS)	21,5 82,00 mm	
<b>RTE</b>	07.1990 → 08.2000	D (NA) 4	1753 cm <sup>3</sup>	2V	44 kW (60 PS)	21,5 82,00 mm	
<b>RTF</b>	07.1990 → 08.2000	D (NA) 4	1753 cm <sup>3</sup>	2V	44 kW (60 PS)	21,5 82,00 mm	
<b>RTG</b>	03.1989 → 02.1996	D (NA) 4	1753 cm <sup>3</sup>	2V	43-44 kW (58-60 PS)	21,5 82,00 mm	
<b>RTH</b>	07.1990 → 08.2000	D (NA) 4	1753 cm <sup>3</sup>	2V	44 kW (60 PS)	21,5 82,00 mm	
<b>RTJ</b>	08.1995 → 04.2002	D (NA) 4	1753 cm <sup>3</sup>	2V	44 kW (60 PS)	21,5 82,00 mm	
<b>RTK</b>	08.1995 → 04.2002	D (NA) 4	1753 cm <sup>3</sup>	2V	44 kW (60 PS)	21,5 82,00 mm	
	IN [2]	36,5 x 8 x 107,0	S - Cr -	- 45° - -	22 - III	1113197 XS4Q 6507 AB	<b>181014</b>
	IN [2]	36,5 x 8 x 107,1	A/S - Cr -	- 45° - -	22 - III	1078433 89FF 6507 AA	<b>18374</b>
	EX [2]	32,0 x 8 x 108,7	A/S - Cr -	- 45° - VS -	22 - III	1198044	<b>181015</b>
	EX [2]	32,0 x 8 x 109,2	A/S - Cr -	- 45° - -	22 - III	1078429 1352129 89FF 6505 AA	<b>18375</b>
	EX [2]	32,0 x 8 x 109,2	A/S - Cr -	- 45° - VS -	22 - III	6172845 6172848 6172854 89FF 6505 FA	<b>18345</b>
	[50]	Ø 8 mm					<b>MK-8H</b>
	IN/EX [4]	12,76 x 7.91 x 38,0	G1			<b>81-5801</b>	
<b>71</b>		<b>82,5</b>					
<b>RFS KAT</b>	02.1993 → 08.2000	D (LA) 4	1753 cm <sup>3</sup>	2V	66 kW (90 PS)	21,5 82,00 mm	
	IN [2]	36,5 x 8 x 107,1	S - Cr -	- 45° - -	22 - III	1012773 6172851 6781621 93FF 6507 AA 93FF 6507 AF	<b>105-35529</b>
	EX [2]	30,7 x 6 x 105,3	RA/S- Cr -	- 45° - VS -	1 - III		<b>537148</b>
	EX [2]	32,0 x 8 x 109,2	A/S - Cr -	- 45° - -	22 - III	1078429 1352129 89FF 6505 AA	<b>18375</b>
	EX [2]	32,0 x 8 x 109,2	A/S - Cr -	- 45° - VS -	22 - III	6172845 6172848 6172854 89FF 6505 FA	<b>18345</b>
	[50]	Ø 8 mm					<b>MK-8H</b>
	IN/EX [4]	12,76 x 7.91 x 38,0	G1			<b>81-5801</b>	
	[8]	H 32 x 26 x 26					<b>50 006 428</b>
<b>72</b>		<b>82,5</b>					
<b>RVA</b>	12.1995 → 06.2001	D (A) 4	1753 cm <sup>3</sup>	2V	51 kW (70 PS)	21,5 82,00 mm	
Fortsetzung nächste Seite / continued on next page / suite page suivante / continuación página próxima / Продолжение на следующей странице							

**F**

					Reference	Item No.
IN [2]	36,5 x 8 x 107,1	A/S - Cr -	- 45° - -	22 - III	1078433 89FF 6507 AA	<b>18374</b>
EX [2]	32,0 x 8 x 109,2	A/S - Cr -	- 45° - -	22 - III	1078429 1352129 89FF 6505 AA	<b>18375</b>
EX [2]	32,0 x 8 x 109,2	A/S - Cr -	- 45° - VS -	22 - III	6172845 6172848 6172854 89FF 6505 FA	<b>18345</b>
[50]	Ø 8 mm					<b>MK-8H</b>
IN/EX [4]	12,76 x 7.91 x 38,0	G1				<b>81-5801</b>

## 73 82,5

BHDA	08.1999 → 03.2005	D (A)	4	1753 cm <sup>3</sup>	2V	55-57 kW (75-78 PS)	19,4:1	82,00 mm
BHDB	08.1999 → 03.2005	D (A)	4	1753 cm <sup>3</sup>	2V	55-57 kW (75-78 PS)	19,4:1	82,00 mm
BHPA	06.2002 → 12.2013	D (LA)	4	1753 cm <sup>3</sup>	2V	55-57 kW (75-78 PS)	19,4:1	82,00 mm
C9DA	08.1998 → 03.2005	D (LA)	4	1753 cm <sup>3</sup>	2V	66 kW (90 PS)	19,4	82,00 mm
C9DB	08.1998 → 03.2005	D (LA)	4	1753 cm <sup>3</sup>	2V	66 kW (90 PS)	19,4	82,00 mm
C9DC	03.1998 → 03.2005	D (A)	4	1753 cm <sup>3</sup>	2V	66 kW (90 PS)	19,4	82,00 mm
F9DA	03.2001 → 03.2005	D (LA)	4	1753 cm <sup>3</sup>	2V	85 kW (115 PS)	18,5	82,00 mm
F9DB	03.2001 → 03.2005	D (LA)	4	1753 cm <sup>3</sup>	2V	85 kW (115 PS)	18,5	82,00 mm
FFBA	03.2007 → 01.2015	D (LA)	4	1753 cm <sup>3</sup>	2V	74 kW (100 PS)	18,5	82,00 mm
FFDA Euro 2	08.2002 → 03.2005	D (LA)	4	1753 cm <sup>3</sup>	2V	74 kW (100 PS)	18,5	82,00 mm
FFWA	05.2006 → 06.2015	D (A)	4	1753 cm <sup>3</sup>	2V	74 kW (100 PS)	18,5	82,00 mm
HCPA	06.2002 → 12.2013	D (LA)	4	1753 cm <sup>3</sup>	2V	66 kW (90 PS)	18,5:1	82,00 mm
HCPB	06.2002 → 12.2013	D (LA)	4	1753 cm <sup>3</sup>	2V	66 kW (90 PS)		82,00 mm
KHBA	06.2007 → 01.2015	D (LA)	4	1753 cm <sup>3</sup>	2V	92 kW (125 PS)		82,00 mm
KKDA Euro 4	07.2004 → 09.2012	D (LA)	4	1753 cm <sup>3</sup>	2V	85 kW (115 PS)	17	82,00 mm
KKDB Euro 4	01.2005 → 09.2010	D (LA)	4	1753 cm <sup>3</sup>	2V	85 kW (115 PS)	17	82,00 mm
P7PA	06.2002 → 12.2013	D (A)	4	1753 cm <sup>3</sup>	2V	55 kW (75 PS)		82,00 mm
QYBA	06.2007 → 01.2015	D (LA)	4	1753 cm <sup>3</sup>	2V	92 kW (125 PS)		82,00 mm
QYWA	05.2006 → 06.2015	D (LA)	4	1753 cm <sup>3</sup>	2V	92 kW (125 PS)		82,00 mm
R2PA	06.2002 → 12.2013	D (A)	4	1753 cm <sup>3</sup>	2V	55 kW (75 PS)		82,00 mm
RTN	03.2000 → 08.2003	D (LA)	4	1753 cm <sup>3</sup>	2V	55-57 kW (75-78 PS)	19,4	82,00 mm
RTP	03.2000 → 08.2003	D (LA)	4	1753 cm <sup>3</sup>	2V	55-57 kW (75-78 PS)	19,4	82,00 mm
RTQ	03.2000 → 08.2003	D (LA)	4	1753 cm <sup>3</sup>	2V	55-57 kW (75-78 PS)	19,4	82,00 mm
RWPA	08.2006 → 12.2013	D (LA)	4	1753 cm <sup>3</sup>	2V	81 kW (110 PS)		82,00 mm

40 014 6..., 99 960 6..., 99 963 6..

IN [2]	36,5 x 8 x 107,0	S - Cr -	- 45° - -	22 - III	1113197 XS4Q 6507 AB	<b>181014</b>
EX [2]	32,0 x 8 x 108,7	A/S - Cr -	- 45° - VS -	22 - III	1198044	<b>181015</b>
[50]	Ø 8 mm					<b>MK-8H</b>
IN/EX [4]	12,76 x 7.91 x 38,0	G1				<b>81-5801</b>
					1078426 XS4Q 6250 AC	<b>50 007 029</b> (1)
(1) Schalenhartguss/chilled cast iron/pièce moulée trempée en surface/fundición en coquilla/Отливка с отбелсным поверхностным слоем						

## 74 82,5

P7PB	06.2002 → 12.2013	D (A)	4	1753 cm <sup>3</sup>	2V	55 kW (75 PS)	82,00 mm
R3PA	06.2002 → 12.2013	D (LA)	4	1753 cm <sup>3</sup>	2V	66 kW (90 PS)	82,00 mm
RWPC	08.2006 → 12.2013	D (LA)	4	1753 cm <sup>3</sup>	2V	81 kW (110 PS)	82,00 mm
RWPD	08.2006 → 12.2013	D (LA)	4	1753 cm <sup>3</sup>	2V	81 kW (110 PS)	82,00 mm
RWPE	06.2002 → 12.2013	D (LA)	4	1753 cm <sup>3</sup>	2V	66 kW (90 PS)	82,00 mm
RWPF	06.2002 → 12.2013	D (LA)	4	1753 cm <sup>3</sup>	2V	66 kW (90 PS)	82,00 mm

Fortsetzung nächste Seite / continued on next page / suite page suivante / continuación página próxima / Продолжение на следующей странице

					Reference	Item No.		
	IN [2]	36,5 x 8 x 107,0	S - Cr -	- 45° - -	22 - III	1113197 XS4Q 6507 AB	<b>181014</b>	
	EX [2]	32,0 x 8 x 108,7	A/S - Cr -	- 45° - VS -	22 - III	1198044	<b>181015</b>	
	[50]	Ø 8 mm					<b>MK-8H</b>	
	IN/EX [4]	12,76 x 7.91 x 38,0	G1				<b>81-5801</b>	
<b>75</b>		<b>83</b>						
CFBA	06.2003 → 03.2007	B (NA)	4	1798 cm <sup>3</sup>	4V	96 kW (130 PS)	11,3	83,10 mm
CGBA	10.2000 → 03.2007	B (NA)	4	1798 cm <sup>3</sup>	4V	81 kW (110 PS)	10,8	83,10 mm
CHBA	10.2000 → 03.2007	B (NA)	4	1798 cm <sup>3</sup>	4V	92 kW (125 PS)	10,8	83,10 mm
CSDA	10.2003 → 03.2007	B (NA)	4	1798 cm <sup>3</sup>	4V	88 kW (120 PS)	10,8	83,10 mm
CSDB	10.2003 → 03.2007	B (NA)	4	1798 cm <sup>3</sup>	4V	88 kW (120 PS)	10,8	83,10 mm
QQDA	04.2004 → 09.2012	B (NA)	4	1798 cm <sup>3</sup>	4V	92 kW (125 PS)	10,8:1	83,10 mm
QQDB	04.2004 → 09.2012	B (NA)	4	1798 cm <sup>3</sup>	4V	92 kW (125 PS)	10,8:1	83,10 mm
QQDC	09.2005 → 09.2010	B (NA)	4	1798 cm <sup>3</sup>	4V	90 kW (122 PS)	10,8:1	83,10 mm
	IN [2]	32,5 x 5,5 x 103,4	S - Ni -	- 45° - -	1 -	1211483 1324691 1S7G 6507 DG		<b>181110</b>
	EX [2]	28,0 x 5,5 x 104,7	A - Ni -	- 45° - -	1 -	1324690 1S7G 6505 DF		<b>181111</b>
<b>76</b>		<b>83</b>						
HUBA	03.2007 → 01.2015	B (LA)	5	2521 cm <sup>3</sup>	4V	162 kW (220 PS)	9	93,20 mm
HUWA	05.2006 → 12.2014	B (LA)	5	2521 cm <sup>3</sup>	4V	162 kW (220 PS)	9	93,20 mm
HYDA	10.2005 → 09.2012	B (LA)	5	2522 cm <sup>3</sup>	4V	166 kW (225 PS)	9	93,20 mm
HYDB	02.2008 → 11.2012	B (LA)	5	2521 cm <sup>3</sup>	4V	147 kW (200 PS)		93,20 mm
HYDC Euro 5	02.2008 → 11.2012	B (LA)	5	2521 cm <sup>3</sup>	4V	147 kW (200 PS)	9	93,20 mm
	IN [2]	31,0 x 6 x 104,3	S - Cr -	- 45° - -	22 - III	1369828 6M5G 6507 AA		<b>471206</b> <small>NEW</small>
	IN [2]	32,0 x 6 x 104,3	S - Ni -	- 45° - -	22 - III			<b>471207</b> <small>NEW</small>
	EX [2]	27,0 x 6 x 103,3	RA/S- Ni -	- 45° - VS -	22 - III	1369831 6M5G 6505 AA		<b>471209</b> <small>NEW</small>
	[50]	Ø 6 mm						<b>MK-6H</b>
<b>77</b>		<b>83</b>						
FS		B (NA)	4	1991 cm <sup>3</sup>	4V	85 kW (116 PS)	9:1	92,00 mm
	[8]	H 27				3395984 3720224		<b>50 007 664</b>
<b>78</b>		<b>84</b>						
NWN	04.1976 → 12.1977	B	6	1999 cm <sup>3</sup>	2V	66 kW (90 PS)	8,75	60,10 mm
NWR	07.1979 → 07.1982	B (NA)	6	1999 cm <sup>3</sup>	2V	66 kW (90 PS)	8,2	60,10 mm
NYL	04.1976 → 12.1982	B	6	1999 cm <sup>3</sup>	2V	66 kW (90 PS)	8,75:1	60,10 mm
NYP	08.1977 → 08.1985	B	6	1998 cm <sup>3</sup>	2V	66 kW (90 PS)	8,75:1	60,10 mm
NYR	05.1975 → 07.1979	B (NA)	6	1999 cm <sup>3</sup>	2V	66 kW (90 PS)	8,75	60,10 mm
NYT	08.1982 → 10.1984	B (NA)	6	1999 cm <sup>3</sup>	2V	66 kW (90 PS)	9	60,10 mm
	IN [2]	42,0 x 8 x 111,2	S - -	- 45° - -	22 - III	70HM 6507 DD		<b>7837</b>
	EX [2]	36,0 x 8 x 110,6	A/S - Cr -	- 45° - -	22 - III	70HM 6505 DE		<b>7885</b>
	[50]	Ø 8 mm						<b>MK-8H</b>
	IN/EX [4]	12,76 x 8.06 x 60,3	G1					<b>81-18110</b>
Fortsetzung nächste Seite / continued on next page / suite page suivante / continuación página próxima / Продолжение на следующей странице								

**F**



					Reference	Item No.	
	EX [4]				6062845 78HM6564AA	50 007 624	
<b>79</b>		<b>84</b>					
ARC	09.1986 → 02.1992	B (NA)	6	2394 cm <sup>3</sup> 2V	96 kW (130 PS)	9,5 72,00 mm	
	IN/EX [4]	11,04 x 6 x 39,0	B1			<b>81-33121</b> <small>NEW</small>	
	IN/EX [4]	11,05 x 6 x 36,0	B1			<b>81-33111</b>	
	IN/EX [4]	11,15 x 6 x 36,0	B1			<b>81-33118</b> <small>NEW</small>	
	EX [4]	11,04 x 6 x 39,0	G2			<b>81-33122</b> <small>NEW</small>	
<b>80</b>		<b>84</b>					
BCCC	07.2018 →	D (LA)	4	1995 cm <sup>3</sup> 4V	140 kW (190 PS)	90,00 mm	
YLDA	01.2018 →	D (A)	4	1995 cm <sup>3</sup> 4V	110 kW (150 PS)	90,00 mm	
YMCB	07.2018 →	D (A)	4	1995 cm <sup>3</sup> 4V	110 kW (150 PS)	90,00 mm	
YNCA	07.2018 →	D (A)	4	1995 cm <sup>3</sup> 4V	88 kW (120 PS)	90,00 mm	
					2325380 HG9Q-6E262-CC HG9Q-6E262-CD	<b>50 007 780</b>	
<b>81</b>		<b>84,01</b>					
BJFA Euro 6	05.2019 →	D (A)	4	1995 cm <sup>3</sup> 4V	77 kW (105 PS)	90,03 mm	
BJFB Euro 6	05.2019 →	D (A)	4	1995 cm <sup>3</sup> 4V	77 kW (105 PS)	90,03 mm	
BKFA Euro 6	05.2019 →	D (A)	4	1995 cm <sup>3</sup> 4V	96 kW (130 PS)	90,03 mm	
BKFB Euro 6	05.2019 →	D (A)	4	1995 cm <sup>3</sup> 4V	96 kW (130 PS)	90,03 mm	
BLFA Euro 6	05.2019 →	D (A)	4	1995 cm <sup>3</sup> 4V	125 kW (170 PS)	90,03 mm	
BLFB Euro 6	05.2019 →	D (A)	4	1995 cm <sup>3</sup> 4V	125 kW (170 PS)	90,03 mm	
YLF6	12.2015 →	D (A)	4	1995 cm <sup>3</sup> 4V	77 kW (105 PS)	16,5 90,03 mm	
YLF6	12.2015 →	D (A)	4	1995 cm <sup>3</sup> 4V	77 kW (105 PS)	16,5 90,03 mm	
YMF6	12.2015 →	D (A)	4	1995 cm <sup>3</sup> 4V	96 kW (130 PS)	16,5 90,03 mm	
YMFA Euro 6	12.2018 →	D (A)	4	1995 cm <sup>3</sup> 4V	96 kW (130 PS)	90,03 mm	
YMF6 Euro 6	05.2019 →	D (A)	4	1995 cm <sup>3</sup> 4V	96 kW (130 PS)	90,03 mm	
YMFS	12.2015 →	D (A)	4	1995 cm <sup>3</sup> 4V	96 kW (130 PS)	16,5 90,03 mm	
YNF6	12.2015 →	D (A)	4	1995 cm <sup>3</sup> 4V	125 kW (170 PS)	16,5 90,03 mm	
YNFA Euro 6	12.2018 →	D (A)	4	1995 cm <sup>3</sup> 4V	125 kW (170 PS)	90,03 mm	
YNFB Euro 6	05.2019 →	D (A)	4	1995 cm <sup>3</sup> 4V	125 kW (170 PS)	90,03 mm	
YNFS	12.2015 →	D (A)	4	1995 cm <sup>3</sup> 4V	125 kW (170 PS)	16,5 90,03 mm	
					2325380 HG9Q-6E262-CC HG9Q-6E262-CD	<b>50 007 780</b>	
<b>82</b>		<b>84,8</b>					
EDBA	08.1998 → 12.2001	B (NA)	4	1988 cm <sup>3</sup> 4V	96 kW (131 PS)	10 88,00 mm	
EDBB	08.1998 → 12.2001	B (NA)	4	1988 cm <sup>3</sup> 4V	96 kW (131 PS)	10 88,00 mm	
EDBC	08.1998 → 12.2001	B (NA)	4	1988 cm <sup>3</sup> 4V	96 kW (131 PS)	10 88,00 mm	
EDBD	08.1998 → 12.2001	B (NA)	4	1988 cm <sup>3</sup> 4V	96 kW (131 PS)	10 88,00 mm	
EDDB	08.1990 →	B (NA)	4	1988 cm <sup>3</sup> 4V	96 kW (131 PS)	10 88,00 mm	
	IN [2]	32,0 x 6 x 97,0	S - Cr -	- 45° - -	22 - III	1041838 928M 6507 F2A	<b>105-35551</b>
	IN [2]	33,0 x 6 x 98,0	S - -	- 45° - -	22 - III	1053845 XS7E 6507 D2A	<b>181012</b>
	IN/EX [4]	12,03 x 6.08 x 36,0	G2				<b>81-18105</b>
<b>83</b>		<b>84,8</b>					
EDDC	08.1990 →	B (NA)	4	1988 cm <sup>3</sup> 4V	96 kW (131 PS)	10 88,00 mm	
	IN [2]	32,0 x 6 x 97,0	S - Cr -	- 45° - -	22 - III	1041838 928M 6507 F2A	<b>105-35551</b>
	EX [2]	28,0 x 6 x 97,6	A/S - Cr -	- 45° - -	22 - III	1053843 1066045 1124514 XS7E 6505 D2D	<b>181021</b>

Fortsetzung nächste Seite / continued on next page / suite page suivante / continuación página próxima / Продолжение на следующей странице



KOLBENSCHMIDT

TRW  
EngineComponents

FORD

					Reference	Item No.	
	IN/EX [4]	12,03 x 6.08 x 36,0	G2			<b>81-18105</b>	
<b>84</b>		<b>84,8</b>					
NGA	08.1990 →	B (NA) 4	1988 cm <sup>3</sup>	4V	96-100 kW (131-136 PS) 10	88,00 mm	
NGC	08.1996 → 09.2000	B (NA) 4	1988 cm <sup>3</sup>	4V	96 kW (131 PS) 10	88,00 mm	
NGD	08.1996 → 09.2000	B (NA) 4	1988 cm <sup>3</sup>	4V	96 kW (131 PS) 10	88,00 mm	
	IN [2]	32,0 x 6 x 97,0	S - Cr -	- 45° - -	22 - III	<b>105-35551</b>	
	EX [2]	28,0 x 6 x 96,7	A/S - Cr -	- 45° - -	22 - III	<b>105-35552</b>	
	EX [2]	28,0 x 6 x 96,7	RA/S- Cr -	- 45° - -	1 - III	<b>18391</b>	
	IN/EX [4]	12,03 x 6.08 x 36,0	G2			<b>81-18105</b>	
<b>85</b>		<b>84,8</b>					
NGB	08.1996 → 09.2000	B (NA) 4	1988 cm <sup>3</sup>	4V	96 kW (131 PS) 10	88,00 mm	
	IN [2]	32,0 x 6 x 97,0	S - Cr -	- 45° - -	22 - III	<b>105-35551</b>	
	EX [2]	28,0 x 6 x 96,7	A/S - Cr -	- 45° - -	22 - III	<b>105-35552</b>	
	IN/EX [4]	12,03 x 6.08 x 36,0	G2			<b>81-18105</b>	
<b>86</b>		<b>85</b>					
4G63		B (NA) 4	1997 cm <sup>3</sup>	2V	78 kW (106 PS) 8,6	88,00 mm	
	EX [2]	30,5 x 6,6 x 109,7	A/S - Ni -	- 45° - -	1 - III	<b>S3438</b>	
	IN [4]	12,13 x 6.62 x 44,0	G1			<b>81-75000</b>	
	[8]	H 13 x 25,5				<b>50 007 599</b>	
<b>87</b>		<b>85</b>					
AZBA	03.2007 → 01.2015	D (LA) 4	1997 cm <sup>3</sup>	4V	96 kW (131 PS) 18	88,00 mm	
AZBC	03.2007 → 12.2014	D (LA) 4	1997 cm <sup>3</sup>	4V	100-103 kW (136-140 PS) 18	88,00 mm	
AZWA	05.2006 → 06.2015	D (LA) 4	1997 cm <sup>3</sup>	4V	96 kW (130 PS) 17,9	88,00 mm	
AZWC	05.2006 → 06.2015	D (LA) 4	1997 cm <sup>3</sup>	4V	100 kW (136 PS) 18	88,00 mm	
G6DA	10.2003 → 09.2012	D (LA) 4	1997 cm <sup>3</sup>	4V	100 kW (136 PS) 18	88,00 mm	
G6DB	10.2003 → 09.2012	D (LA) 4	1997 cm <sup>3</sup>	4V	100 kW (136 PS) 18	88,00 mm	
G6DC	10.2003 → 09.2010	D (LA) 4	1997 cm <sup>3</sup>	4V	98 kW (133 PS) 18	88,00 mm	
G6DD	10.2003 → 09.2012	D (LA) 4	1997 cm <sup>3</sup>	4V	100 kW (136 PS) 18	88,00 mm	
G6DE	10.2003 → 09.2010	D (LA) 4	1997 cm <sup>3</sup>	4V	98 kW (133 PS) 18	88,00 mm	
G6DF	10.2003 → 09.2010	D (LA) 4	1997 cm <sup>3</sup>	4V	98 kW (133 PS) 18	88,00 mm	
G6DG	10.2003 → 11.2012	D (LA) 4	1997 cm <sup>3</sup>	4V	100 kW (136 PS) 18	88,00 mm	
KLBA Euro 4	11.2007 → 01.2015	D (LA) 4	1997 cm <sup>3</sup>	4V	85 kW (116 PS) 18	88,00 mm	
KLWA	01.2007 → 06.2015	D (LA) 4	1997 cm <sup>3</sup>	4V	85 kW (115 PS)	88,00 mm	
LPBA	11.2007 → 01.2015	D (LA) 4	1997 cm <sup>3</sup>	4V	85 kW (115 PS) 18	88,00 mm	
QXBA Euro 4	03.2007 → 01.2015	D (LA) 4	1997 cm <sup>3</sup>	4V	103 kW (140 PS) 18	88,00 mm	
QXBB Euro 4	03.2007 → 01.2015	D (LA) 4	1997 cm <sup>3</sup>	4V	103 kW (140 PS) 18	88,00 mm	
QXWA	05.2006 → 06.2015	D (LA) 4	1997 cm <sup>3</sup>	4V	103 kW (140 PS) 17,9	88,00 mm	
QXWB Euro 4	05.2006 → 06.2015	D (LA) 4	1997 cm <sup>3</sup>	4V	103 kW (140 PS) 17,9	88,00 mm	
99 700 6..							
Fortsetzung nächste Seite / continued on next page / suite page suivante / continuación página próxima / Продолжение на следующей странице							

F

					Reference	Item No.
IN [2]	30,0 x 6 x 105,0	S - Cr -	- 45° - -	22 - III	1231931 3M5Q 6507 BA	<b>181104</b>
EX [2]	25,0 x 6 x 105,0	A/S - Cr -	- 45° - VS -	22 - III	1231930 1675716 3M5Q 6505 BA	<b>181105</b>
[50]	Ø 6 mm					<b>MK-6H</b>
IN/EX [4]	10,52 x 6 x 41,5	G1				<b>81-5330</b>
	ES				1707012 3M5Q-6A270-BB	<b>50 007 096</b> <small>NEW</small>
	AS				1495923 3M5Q 6A273 BB	<b>50 007 099</b> <small>NEW</small>
[8]	H 12 x 34,5				1231929 1331285 3M5Q6500AB	<b>50 006 145</b>
[4]					1255011 1594826 3M5Q6564BB	<b>50 006 096</b> (1)
(1) mit Clip, with clip, avec clip, con clip, с брелоком-зажимом						

## 88

**QXWC Euro 4** 05.2006 → 06.2015 D (LA) 4 1997 cm<sup>3</sup> 4V 103 kW (140 PS) 17,9 88,00 mm

IN [2]	30,0 x 6 x 105,0	S - Cr -	- 45° - -	22 - III	1231931 3M5Q 6507 BA	<b>181104</b>
EX [2]	25,0 x 6 x 105,0	A/S - Cr -	- 45° - VS -	22 - III	1231930 1675716 3M5Q 6505 BA	<b>181105</b>
[50]	Ø 6 mm					<b>MK-6H</b>
IN/EX [4]	10,52 x 6 x 41,5	G1				<b>81-5330</b>
[8]	H 12 x 34,5				1231929 1331285 3M5Q6500AB	<b>50 006 145</b>
[4]					1255011 1594826 3M5Q6564BB	<b>50 006 096</b> (1)
(1) mit Clip, with clip, avec clip, con clip, с брелоком-зажимом						

## 89

**TYBA** 11.2007 → 01.2015 D (LA) 4 1997 cm<sup>3</sup> 4V 85 kW (115 PS) 18 88,00 mm

[8]	H 12 x 34,5				1231929 1331285 3M5Q6500AB	<b>50 006 145</b>
[4]					1255011 1594826 3M5Q6564BB	<b>50 006 096</b> (1)
(1) mit Clip, with clip, avec clip, con clip, с брелоком-зажимом						

## 90

**Q4BA Euro 4** 03.2008 → 10.2010 D (LA) 4 2179 cm<sup>3</sup> 4V 129 kW (175 PS) 16,6 96,00 mm

Fortsetzung nächste Seite / continued on next page / suite page suivante / continuación página próxima / Продолжение на следующей странице						
--	--	--	--	--	--	--

					Reference	Item No.	
	IN [2] IN [2]	27,3 x 6 x 96,0 29,8 x 7 x 122,2	S - Cr - S - Cr -	- 45° - - - 30° - -	22 - III 22 - III	1871590 1121331 1121333 1216915 1217148 1738494 BK2Q 6507 BB XS7Q 6507 A1B XS7Q 6507 A1C XS7Q 6507 A2B XS7Q 6507 A2C	<b>539050</b> <small>NEW</small> <b>181018</b>
	EX [2]	24,7 x 6 x 95,0	RA/S- Cr -	- 45° - VS -	22 - III	1698383 1871583 BG9Q6505AB	<b>539051</b> <small>NEW</small>
	EX [2]	25,8 x 7 x 122,1	A/S - Cr -	- 45° - VS -	22 - III	1121332 1132466 1132467 1214456 1376413 1706989 1706990 2S7Q 6505 A1B 2S7Q 6505 A2A 2S7Q 6505 AC BK2Q 6505 BA BK2Q 6505 BB XS7Q 6505 A2B	<b>181019</b>
	[50] [50]	Ø 6 mm Ø 7 mm					<b>MK-6H</b> <b>MK-7H</b>
	IN/EX [4]	12,07 x 7.02 x 51,5	G2			XS7Q6510AC	<b>81-18112</b> <small>NEW</small>
		AS				1349548 4C1Q 6A273 BB	<b>50 007 085</b> <small>NEW</small>
		ES				1349550 4C1Q 6A270 BB	<b>50 007 095</b> <small>NEW</small>
	[8]	H 12 x 33				1450604 6G9Q-6500-AA	<b>50 006 494</b>
	[4]					6G9Q 6564 BA	<b>50 007 848</b>

**F**

<b>91</b>		<b>85</b>	<b>Q4WA Euro 4</b>						03.2008 → 12.2012	D (LA)	4	2179 cm <sup>3</sup>	4V	129 kW	(175 PS)	16,6	96,00 mm
-----------	--	-----------	--------------------	--	--	--	--	--	-------------------	--------	---	----------------------	----	--------	----------	------	----------

Fortsetzung nächste Seite / continued on next page / suite page suivante / continuación página próxima / Продолжение на следующей странице

					Reference	Item No.
IN [2]	29,8 x 7 x 122,2	S - Cr -	- 30° - -	22 - III	1121331 1121333 1216915 1217148 1738494 BK2Q 6507 BB XS7Q 6507 A1B XS7Q 6507 A1C XS7Q 6507 A2B XS7Q 6507 A2C	<b>181018</b>
EX [2]	25,8 x 7 x 122,1	A/S - Cr -	- 45° - VS -	22 - III	1121332 1132466 1132467 1214456 1376413 1706989 1706990 2S7Q 6505 A1B 2S7Q 6505 A2A 2S7Q 6505 AC BK2Q 6505 BA BK2Q 6505 BB XS7Q 6505 A2B	<b>181019</b>
[50]	Ø 7 mm					<b>MK-7H</b>
IN/EX [4]	12,07 x 7.02 x 51,5	G2			XS7Q6510AC	<b>81-18112</b> <small>NEW</small>
	AS				1349548 4C1Q 6A273 BB	<b>50 007 085</b> <small>NEW</small>
	ES				1349550 4C1Q 6A270 BB	<b>50 007 095</b> <small>NEW</small>
[8]	H 12 x 33				1450604 6G9Q-6500-AA	<b>50 006 494</b>
[4]					6G9Q 6564 BA	<b>50 007 848</b>
<b>92</b>	<b>85</b>					
<b>TXDA</b>	03.2010 →	D (LA)	4	1997 cm <sup>3</sup> 4V	118-120 kW (160-163 PS)	88,00 mm
<b>UFDA</b>	03.2010 → 11.2012	D (LA)	4	1997 cm <sup>3</sup> 4V	103 kW (140 PS)	88,00 mm
<b>UKDA</b>	03.2008 → 11.2012	D (LA)	4	1997 cm <sup>3</sup> 4V	100 kW (136 PS) 18	88,00 mm
99 700 6..						
IN [2]	27,2 x 6 x 104,5	S - Cr -	- 45° - Y -	22 - III	1683701 9M5Q 6507 AA	<b>181117</b> <small>NEW</small>
EX [2]	25,0 x 6 x 105,0	A/S - Cr -	- 45° - VS -	22 - III	1231930 1675716 3M5Q 6505 BA	<b>181105</b>
[50]	Ø 6 mm					<b>MK-6H</b>
IN/EX [4]	10,52 x 6 x 41,5	G1				<b>81-5330</b>
[8]	H 12 x 34,5				1231929 1331285 3M5Q6500AB	<b>50 006 145</b>
IN [8]					1683702 9M5Q 6564 AA	<b>50 007 628</b>
EX [8]					1684538 9M5Q 6576 AA	<b>50 007 627</b>



					Reference	Item No.	
<b>93</b>		<b>85</b>					
<b>TXBA</b>	03.2010 → 01.2015	D (LA)	4	1997 cm <sup>3</sup>	4V	120 kW (163 PS)	88,00 mm
<b>TXBB</b>	03.2010 → 01.2015	D (LA)	4	1997 cm <sup>3</sup>	4V	120 kW (163 PS)	88,00 mm
<b>TXMA</b>	03.2013 →	D (LA)	4	1997 cm <sup>3</sup>	4V	120 kW (163 PS) 16	88,00 mm
<b>TXWA</b>	03.2010 → 06.2015	D (LA)	4	1997 cm <sup>3</sup>	4V	118-120 kW (160-163 PS)	88,00 mm
41 251 6..							
	IN [2]	27,2 x 6 x 104,5	S - Cr -	- 45° - Y -	22 - III	1683701 9M5Q 6507 AA	<b>181117</b>
	EX [2]	25,0 x 6 x 105,0	A/S - Cr -	- 45° - VS -	22 - III	1231930 1675716 3M5Q 6505 BA	<b>181105</b>
	[50]	Ø 6 mm					<b>MK-6H</b>
	IN/EX [4]	10,52 x 6 x 41,5	G1				<b>81-5330</b>
<b>94</b>		<b>85</b>					
<b>TXDB</b>	07.2010 →	D (LA)	4	1997 cm <sup>3</sup>	4V	120 kW (163 PS)	88,00 mm
<b>TYDA</b>	07.2010 →	D (LA)	4	1997 cm <sup>3</sup>	4V	85 kW (116 PS)	88,00 mm
<b>UFDB</b>	04.2010 →	D (LA)	4	1997 cm <sup>3</sup>	4V	103 kW (140 PS)	88,00 mm
<b>UKDB</b>	07.2010 →	D (LA)	4	1997 cm <sup>3</sup>	4V	100 kW (136 PS)	88,00 mm
	IN [2]	27,2 x 6 x 104,5	S - Cr -	- 45° - Y -	22 - III	1683701 9M5Q 6507 AA	<b>181117</b>
	EX [2]	25,0 x 6 x 105,0	A/S - Cr -	- 45° - VS -	22 - III	1231930 1675716 3M5Q 6505 BA	<b>181105</b>
	[50]	Ø 6 mm					<b>MK-6H</b>
	IN/EX [4]	10,52 x 6 x 41,5	G1				<b>81-5330</b>
		AS				5252049 CM5E-6C525-DD	<b>50 007 779</b>
	[8]	H 12 x 34,5				1231929 1331285 3M5Q6500AB	<b>50 006 145</b>
	IN [8]					1683702 9M5Q 6564 AA	<b>50 007 628</b>
	EX [8]					1684538 9M5Q 6576 AA	<b>50 007 627</b>
<b>95</b>		<b>85</b>					
<b>KNWA</b>	07.2010 → 06.2015	D (LA)	4	2179 cm <sup>3</sup>	4V	147 kW (200 PS)	96,00 mm
Fortsetzung nächste Seite / continued on next page / suite page suivante / continuación página próxima / Продолжение на следующей странице							

**F**

					Reference	Item No.
IN [2]	29,8 x 7 x 122,2	S - Cr -	- 30° - -	22 - III	1121331 1121333 1216915 1217148 1738494 BK2Q 6507 BB XS7Q 6507 A1B XS7Q 6507 A1C XS7Q 6507 A2B XS7Q 6507 A2C	<b>181018</b>
<b>F</b> EX [2]	25,8 x 7 x 122,1	A/S - Cr -	- 45° - VS -	22 - III	1121332 1132466 1132467 1214456 1376413 1706989 1706990 2S7Q 6505 A1B 2S7Q 6505 A2A 2S7Q 6505 AC BK2Q 6505 BA BK2Q 6505 BB XS7Q 6505 A2B	<b>181019</b>
[50]	Ø 7 mm					<b>MK-7H</b>
IN/EX [4]	12,07 x 7.02 x 51,5	G2			XS7Q6510AC	<b>81-18112</b> <small>NEW</small>
[8]	H 12 x 33				1450604 6G9Q-6500-AA	<b>50 006 494</b>
[4]					6G9Q 6564 BA	<b>50 007 848</b>

## 96

## 85

KNBA	07.2010 → 01.2015	D (LA)	4	2179 cm <sup>3</sup>	4V	147 kW	(200 PS)	96,00 mm
KNBB		D (LA)	4	2179 cm <sup>3</sup>	4V	146 kW	(199 PS)	96,00 mm
T7CE	09.2014 →	D (LA)	4	1998 cm <sup>3</sup>	4V	110 kW	(150 PS) 17	88,00 mm
T7CJ	01.2015 → 06.2018	D (LA)	4	1997 cm <sup>3</sup>	4V	110 kW	(150 PS)	88,00 mm
T7CK	01.2015 → 06.2018	D (LA)	4	1997 cm <sup>3</sup>	4V	110 kW	(150 PS)	88,00 mm
T7CL	01.2015 → 06.2018	D (LA)	4	1997 cm <sup>3</sup>	4V	110 kW	(150 PS)	88,00 mm
T7DB	11.2014 →	D (LA)	4	1997 cm <sup>3</sup>	4V	110 kW	(150 PS) 17	88,00 mm
T7MA	09.2014 →	D (LA)	4	1997 cm <sup>3</sup>	4V	110 kW	(150 PS) 16,7	88,00 mm
T7MB	09.2014 →	D (LA)	4	1997 cm <sup>3</sup>	4V	110 kW	(150 PS) 16,7	88,00 mm
T8CC	09.2014 →	D (LA)	4	1997 cm <sup>3</sup>	4V	132 kW	(180 PS) 17	88,00 mm
T8CD	09.2014 →	D (LA)	4	1997 cm <sup>3</sup>	4V	132 kW	(180 PS) 17	88,00 mm
T8CH	01.2015 → 06.2018	D (LA)	4	1997 cm <sup>3</sup>	4V	132 kW	(180 PS)	88,00 mm
T8CI	01.2015 → 06.2018	D (LA)	4	1997 cm <sup>3</sup>	4V	132 kW	(180 PS)	88,00 mm
T8CJ	01.2015 → 06.2018	D (LA)	4	1997 cm <sup>3</sup>	4V	132 kW	(180 PS)	88,00 mm
T8CL	09.2014 →	D (LA)	4	1997 cm <sup>3</sup>	4V	132 kW	(180 PS) 17	88,00 mm
T8DA	11.2014 →	D (LA)	4	1997 cm <sup>3</sup>	4V	136 kW	(185 PS)	88,00 mm
T8DE	03.2015 →	D (LA)	4	1997 cm <sup>3</sup>	4V	125 kW	(170 PS) 17	88,00 mm
T8MA	09.2014 →	D (LA)	4	1997 cm <sup>3</sup>	4V	132 kW	(180 PS) 16,7	88,00 mm
T8MB	09.2014 →	D (LA)	4	1997 cm <sup>3</sup>	4V	132 kW	(180 PS) 16,7	88,00 mm
T9CA	03.2015 →	D (LA)	4	1997 cm <sup>3</sup>	4V	154 kW	(210 PS) 16,7	88,00 mm
T9CB	01.2015 → 06.2018	D (LA)	4	1997 cm <sup>3</sup>	4V	154 kW	(210 PS)	88,00 mm
T9CC	01.2015 → 06.2018	D (LA)	4	1997 cm <sup>3</sup>	4V	154 kW	(210 PS)	88,00 mm
UFCA	01.2015 → 06.2018	D (LA)	4	1997 cm <sup>3</sup>	4V	88 kW	(120 PS)	88,00 mm
UFCB	01.2015 → 06.2018	D (LA)	4	1997 cm <sup>3</sup>	4V	88 kW	(120 PS)	88,00 mm



[4]

6G9Q 6564 BA

**50 007 848**

					Reference	Item No.	
<b>97</b>	<b>85</b>						
<b>AHW Euro 6</b>	D (A)	4	1997 cm <sup>3</sup>	4V	133 kW (180 PS)	88,00 mm	
<b>AHX Euro 6</b>	D (A)	4	1997 cm <sup>3</sup>	4V	110 kW (150 PS)	88,00 mm	
IN [2]	27,3 x 6 x 96,0	S - Cr -	- 45° -	-	22 - III	1871590	
EX [2]	24,7 x 6 x 95,0	RA/S- Cr -	- 45° -	VS -	22 - III	1698383 1871583 BG9Q6505AB	
[50]	Ø 6 mm					<b>MK-6H</b>	
<b>98</b>	<b>85</b>						
<b>KNWB</b>	D (LA)	4	2179 cm <sup>3</sup>	4V	146 kW (199 PS)	96,00 mm	
[8]	H 12 x 33					1450604 6G9Q-6500-AA	
<b>99</b>	<b>86</b>						
<b>NSH KAT</b>	06.1994 → 12.2000	BG (NA)	4	1998 cm <sup>3</sup>	2V	74-84 kW (101-114 PS)	9,5
[50]	Ø 7 mm						
IN/EX [4]	13,55 x 7.05 x 43,0	G1				6172956	
EX [4]						6062845 78HM6564AA	
<b>100</b>	<b>86</b>						
<b>N8A</b>	10.1988 → 02.1993	B (NA)	4	1998 cm <sup>3</sup>	2V	80 kW (109 PS)	10,3
<b>N8C</b>	12.1989 → 02.1993	B (NA)	4	1993 cm <sup>3</sup>	2V	77 kW (105 PS)	10,3
<b>N8D</b>	04.1985 → 08.1989	B (NA)	4	1993 cm <sup>3</sup>	2V	77 kW (105 PS)	10,3
IN [2]	42,0 x 8 x 111,2	S - -	- 45° -	-	22 - III	70HM 6507 DD	
EX [2]	36,0 x 8 x 110,6	A/S - Cr -	- 45° -	-	22 - III	70HM 6505 DE	
[50]	Ø 8 mm						
IN/EX [4]	12,76 x 8.06 x 60,3	G1					
						1584660 78HM 6250 BA	
	(1) Schalenhartguss/chilled cast iron/pièce moulée trempée en surface/fundición en coquilla/Отливка с отбелсным поверхностным слоем						
EX [4]						6062845 78HM6564AA	
<b>101</b>	<b>86</b>						
<b>N9A</b>	01.1990 → 02.1993	B (NA)	4	1998 cm <sup>3</sup>	2V	90 kW (122 PS)	10,3
<b>N9B</b>	05.1989 → 02.1993	B (NA)	4	1998 cm <sup>3</sup>	2V	92 kW (125 PS)	10,3
<b>N9C</b>	05.1989 → 03.1993	B (NA)	4	1998 cm <sup>3</sup>	2V	88-92 kW (120-125 PS)	10,3
<b>N9D</b>	05.1989 → 09.1994	B (NA)	4	1998 cm <sup>3</sup>	2V	88 kW (120 PS)	10,3
<b>N9F</b>	09.1991 → 12.1994	B (NA)	4	1998 cm <sup>3</sup>	2V	85 kW (115 PS)	10,3
<b>NSD</b>	10.1994 → 08.1998	B (NA)	4	1998 cm <sup>3</sup>	2V	85 kW (115 PS)	9,8
<b>NSE</b>	11.1995 → 05.2006	B (NA)	4	1998 cm <sup>3</sup>	2V	85 kW (116 PS)	9,8
<b>NSF</b>	06.1994 → 03.2006	B (NA)	4	1998 cm <sup>3</sup>	2V	84 kW (114 PS)	9,8
<b>NSG</b>	06.1994 → 12.2000	B (NA)	4	1998 cm <sup>3</sup>	2V	84 kW (114 PS)	9,8
<b>ZVSA</b>	11.1995 → 05.2006	B (NA)	4	1998 cm <sup>3</sup>	2V	85 kW (116 PS)	9,8:1
99 380 6..							
Fortsetzung nächste Seite / continued on next page / suite page suivante / continuación página próxima / Продолжение на следующей странице							

**F**

					Reference	Item No.	
[50]	Ø 7 mm					<b>MK-7H</b>	
IN/EX [4]	13,55 x 7.05 x 43,0	G1			6172956	<b>81-17100</b>	
EX [4]					6062845 78HM6564AA	<b>50 007 624</b>	
<b>102</b>	<b>86</b>						
<b>N7A</b>	05.1991 → 10.1998	B (NA)	4	1998 cm <sup>3</sup> 4V	110 kW (150 PS) 10,3	86,00 mm	
EX [2]	28,0 x 6 x 96,7	RA/S- Cr -		- 45° - -	1 - III	6640542 928M 6505 D2A	<b>18391</b>
IN/EX [4]	12,03 x 6.08 x 36,0	G2					<b>81-18105</b>
<b>103</b>	<b>86</b>						
<b>RF</b>	03.1983 → 03.1992	D (NA)	4	1998 cm <sup>3</sup> 2V	41-55 kW (56-75 PS) 22,7	86,00 mm	
EX [4]	14,02 x 7.98 x 37,7	G2					<b>81-73000</b>
<b>104</b>	<b>86</b>						
<b>ABFA</b>	06.2000 →	D (A)	4	1998 cm <sup>3</sup> 4V	74 kW (101 PS) 19	86,00 mm	
<b>D3FA</b>	06.2000 → 05.2006	D (A)	4	1998 cm <sup>3</sup> 4V	55 kW (75 PS) 19:1	86,00 mm	
<b>D5BA</b>	10.2000 → 03.2007	D (A)	4	1998 cm <sup>3</sup> 4V	66 kW (90 PS) 19,5	86,00 mm	
<b>D6BA</b>	10.2000 → 03.2007	D (A)	4	1998 cm <sup>3</sup> 4V	85 kW (115 PS) 19,5	86,00 mm	
<b>F3FA</b>	08.2000 → 05.2006	D (A)	4	1998 cm <sup>3</sup> 4V	63 kW (86 PS) 19:1	86,00 mm	
<b>FIFA</b>	03.2002 → 05.2006	D (A)	4	1998 cm <sup>3</sup> 4V	92 kW (125 PS) 19:1	86,00 mm	
<b>FMBA</b>	10.2001 → 03.2007	D (A)	4	1998 cm <sup>3</sup> 4V	96 kW (130 PS) 18,2	86,00 mm	
<b>HJBA</b>	10.2000 → 03.2007	D (LA)	4	1998 cm <sup>3</sup> 4V	85 kW (115 PS) 18,5	86,00 mm	
<b>HJBB</b>	10.2000 → 03.2007	D (LA)	4	1998 cm <sup>3</sup> 4V	85 kW (115 PS) 18,5	86,00 mm	
<b>N7BA</b>	10.2001 → 03.2007	D (A)	4	1998 cm <sup>3</sup> 4V	96 kW (130 PS) 18,2	86,00 mm	
<b>QJBA</b>	09.2004 → 03.2007	D (LA)	4	2198 cm <sup>3</sup> 4V	114 kW (155 PS) 17,5	94,60 mm	
<b>QJBB</b>	09.2004 → 03.2007	D (LA)	4	2198 cm <sup>3</sup> 4V	114 kW (155 PS) 17,5	94,60 mm	
<b>QJBC</b>	09.2004 → 03.2007	D (LA)	4	2198 cm <sup>3</sup> 4V	110 kW (150 PS) 17,5	94,60 mm	
<b>QJBD</b>	09.2004 → 03.2007	D (LA)	4	2198 cm <sup>3</sup> 4V	110 kW (150 PS) 17,5	94,60 mm	
<b>SDBA</b>	10.2000 → 03.2007	D (A)	4	1998 cm <sup>3</sup> 4V	66 kW (90 PS) 19,5	86,00 mm	
40 173 6.., 40 174 6..							
IN [2]	29,8 x 7 x 122,2	S - Cr -		- 30° - -	22 - III	1121331 1121333 1216915 1217148 1738494 BK2Q 6507 BB XS7Q 6507 A1B XS7Q 6507 A1C XS7Q 6507 A2B XS7Q 6507 A2C	<b>181018</b>
EX [2]	25,8 x 7 x 122,1	A/S - Cr -		- 45° - VS -	22 - III	1121332 1132466 1132467 1214456 1376413 1706989 1706990 2S7Q 6505 A1B 2S7Q 6505 A2A 2S7Q 6505 AC BK2Q 6505 BA BK2Q 6505 BB XS7Q 6505 A2B	<b>181019</b>

Fortsetzung nächste Seite / continued on next page / suite page suivante / continuación página próxima / Продолжение на следующей странице

					Reference	Item No.
[50]	Ø 7 mm					<b>MK-7H</b>
IN/EX [4]	12,07 x 7.02 x 51,5	G2			XS7Q6510AC	<b>81-18112</b> <small>NEW</small>
	AS ES				1349548 4C1Q 6A273 BB 1349550 4C1Q 6A270 BB	<b>50 007 085</b> <small>NEW</small> <b>50 007 095</b> <small>NEW</small>
[4] [4]  (1) long (2) short					1120750 XS7Q6529A1C 1120752 XS7Q6K528A1C	<b>50 007 610</b> (1) <b>50 007 611</b> (2)

**105** **86**  
**HJBC** 10.2000 → 03.2007 D (LA) 4 1998 cm<sup>3</sup> 4V 85 kW (115 PS) 18,5 86,00 mm  
 40 174 6..

IN [2]	29,8 x 7 x 122,2	S - Cr -	- 30° - -	22 - III	1121331 1121333 1216915 1217148 1738494 BK2Q 6507 BB XS7Q 6507 A1B XS7Q 6507 A1C XS7Q 6507 A2B XS7Q 6507 A2C	<b>181018</b>
EX [2]	25,8 x 7 x 122,1	A/S - Cr -	- 45° - VS -	22 - III	1121332 1132466 1132467 1214456 1376413 1706989 1706990 2S7Q 6505 A1B 2S7Q 6505 A2A 2S7Q 6505 AC BK2Q 6505 BA BK2Q 6505 BB XS7Q 6505 A2B	<b>181019</b>
[50]	Ø 7 mm					<b>MK-7H</b>
IN/EX [4] IN/EX [4]	10,05 x 5.99 x 45,0 12,07 x 7.02 x 51,5	G1 G2			XS7Q6510AC	<b>81-4200</b> <b>81-18112</b> <small>NEW</small>
	AS ES				1349548 4C1Q 6A273 BB 1349550 4C1Q 6A270 BB	<b>50 007 085</b> <small>NEW</small> <b>50 007 095</b> <small>NEW</small>
[4] [4]  (1) long (2) short					1120750 XS7Q6529A1C 1120752 XS7Q6K528A1C	<b>50 007 610</b> (1) <b>50 007 611</b> (2)



					Reference	Item No.
<b>106</b>	86					
<b>N7BB</b>	10.2001 → 03.2007	D (LA)	4	1998 cm <sup>3</sup> 4V	96 kW (131 PS) 18:1	86,00 mm
	IN [2] 29,8 x 7 x 122,2	S - Cr -	- 30° - -	22 - III	1121331 1121333 1216915 1217148 1738494 BK2Q 6507 BB XS7Q 6507 A1B XS7Q 6507 A1C XS7Q 6507 A2B XS7Q 6507 A2C	<b>181018</b>
	EX [2] 25,8 x 7 x 122,1	A/S - Cr -	- 45° - VS -	22 - III	1121332 1132466 1132467 1214456 1376413 1706989 1706990 2S7Q 6505 A1B 2S7Q 6505 A2A 2S7Q 6505 AC BK2Q 6505 BA BK2Q 6505 BB XS7Q 6505 A2B	<b>181019</b>
	[50] ∅ 7 mm					<b>MK-7H</b>
	IN/EX [4] 12,07 x 7.02 x 51,5	G2			XS7Q6510AC	<b>81-18112</b> <small>NEW</small>
	AS ES				1349548 4C1Q 6A273 BB 1349550 4C1Q 6A270 BB	<b>50 007 085</b> <small>NEW</small> <b>50 007 095</b> <small>NEW</small>
<b>107</b>	86					
<b>CVF5</b>	08.2013 → 12.2018	D (LA)	4	2198 cm <sup>3</sup> 4V	114 kW (155 PS) 15,5	94,60 mm
<b>CVFF</b>	04.2012 → 12.2015	D (LA)	4	2198 cm <sup>3</sup> 4V	114 kW (155 PS) 15,5	94,60 mm
<b>CYF5</b>	08.2013 → 12.2018	D (LA)	4	2198 cm <sup>3</sup> 4V	92-99 kW (125-135 PS) 15,5	94,60 mm
<b>CYFA</b>	10.2011 → 08.2014	D (LA)	4	2198 cm <sup>3</sup> 4V	92 kW (125 PS) 15,5	94,60 mm
<b>CYFB</b>	10.2011 → 08.2014	D (LA)	4	2198 cm <sup>3</sup> 4V	92 kW (125 PS) 15,5	94,60 mm
<b>CYFC</b>	10.2011 → 08.2014	D (LA)	4	2198 cm <sup>3</sup> 4V	92 kW (125 PS) 15,5	94,60 mm
<b>CYFF</b>	04.2012 → 12.2015	D (LA)	4	2198 cm <sup>3</sup> 4V	92 kW (125 PS) 15,5	94,60 mm
<b>CYFG</b>	08.2013 → 12.2018	D (LA)	4	2198 cm <sup>3</sup> 4V	92 kW (125 PS) 15,5	94,60 mm
<b>DRF5</b>	08.2013 → 12.2018	D (A)	4	2198 cm <sup>3</sup> 4V	74 kW (100 PS) 15,5	94,60 mm
<b>DRFA</b>	10.2011 → 08.2014	D (LA)	4	2198 cm <sup>3</sup> 4V	74 kW (101 PS) 15,5	94,60 mm
<b>DRFB</b>	10.2011 → 08.2014	D (LA)	4	2198 cm <sup>3</sup> 4V	74 kW (101 PS) 15,5	94,60 mm
<b>DRFC</b>	10.2011 → 08.2014	D (LA)	4	2198 cm <sup>3</sup> 4V	74 kW (101 PS) 15,5	94,60 mm
<b>DRFF</b>	04.2012 → 12.2018	D (LA)	4	2198 cm <sup>3</sup> 4V	74 kW (100 PS) 15,5	94,60 mm
<b>DRFG</b>	04.2012 → 12.2018	D (LA)	4	2198 cm <sup>3</sup> 4V	74 kW (100 PS) 15,5	94,60 mm
<b>P8FA Euro 4</b>	04.2006 → 08.2014	D (A)	4	2198 cm <sup>3</sup> 4V	63 kW (85 PS) 17,5	94,60 mm
<b>P8FB Euro 4</b>	04.2006 → 08.2014	D (A)	4	2198 cm <sup>3</sup> 4V	63 kW (85 PS) 17,5	94,60 mm
<b>PGFA Euro 4</b>	10.2007 → 08.2014	D (LA)	4	2198 cm <sup>3</sup> 4V	103 kW (140 PS) 15,5	94,60 mm
<b>PGFB</b>	10.2007 → 08.2014	D (LA)	4	2198 cm <sup>3</sup> 4V	103 kW (140 PS) 15,5	94,60 mm
<b>QVFA Euro 4</b>	04.2006 → 08.2014	D (A)	4	2198 cm <sup>3</sup> 4V	81 kW (110 PS) 17,5	94,60 mm
<b>QWFA Euro 4</b>	04.2006 → 08.2014	D (A)	4	2198 cm <sup>3</sup> 4V	96 kW (130 PS) 17,5	94,60 mm
<b>SRFA</b>	10.2008 → 08.2014	D (LA)	4	2198 cm <sup>3</sup> 4V	85 kW (115 PS) 17,5	94,60 mm
<b>SRFB</b>	10.2008 → 08.2014	D (LA)	4	2198 cm <sup>3</sup> 4V	85 kW (115 PS) 17,5	94,60 mm
<b>SRFC</b>	10.2008 → 08.2014	D (LA)	4	2198 cm <sup>3</sup> 4V	85 kW (115 PS) 17,5	94,60 mm
<b>SRFD</b>	10.2008 → 08.2014	D (LA)	4	2198 cm <sup>3</sup> 4V	85 kW (115 PS) 17,5	94,60 mm
<b>SRFE</b>	10.2008 → 08.2014	D (LA)	4	2198 cm <sup>3</sup> 4V	85 kW (115 PS) 17,5	94,60 mm
41 008 6..., 41 072 6..., 41 252 6..., 41 765 6...						
Fortsetzung nächste Seite / continued on next page / suite page suivante / continuación página próxima / Продолжение на следующей странице						

					Reference	Item No.
IN [2]	29,8 x 7 x 122,2	S - Cr -	- 30° - -	22 - III	1121331 1121333 1216915 1217148 1738494 BK2Q 6507 BB XS7Q 6507 A1B XS7Q 6507 A1C XS7Q 6507 A2B XS7Q 6507 A2C	<b>181018</b>
EX [2]	25,8 x 7 x 122,1	A/S - Cr -	- 45° - VS -	22 - III	1121332 1132466 1132467 1214456 1376413 1706989 1706990 2S7Q 6505 A1B 2S7Q 6505 A2A 2S7Q 6505 AC BK2Q 6505 BA BK2Q 6505 BB XS7Q 6505 A2B	<b>181019</b>
[50]	Ø 7 mm					<b>MK-7H</b>
IN/EX [4]	12,07 x 7.02 x 51,5	G2			XS7Q6510AC	<b>81-18112</b>
	ES AS  (1) Schalenhartguss/chilled cast iron/pièce moulée trempée en surface/fundición en coquilla/Отливка с отбеленным поверхностным слоем  (2) gebaute Nockenwelle Assembled camshaft arbre à cames composé Árbol de levas montado сборный распределительный вал				1688422 6C1Q6A270AD 1372430 6C1Q6A273AC	<b>50 007 050</b> (1) <b>50 007 051</b> (2)
[8]	H 11 x 24,5  (3) nur Ventilstößel only valve tappet seulement poignée de soupape solo manija de válvula только рукоятка клапана				6C1Q-6K551-BA	<b>50 007 652</b> (3)
[8] [1]	  (4) nur Schleppebel only rocker arm seulement culbuteur solamente palanca de arrastre только балансир  (5) Kipphebelbrücke rocker arm bridge pont de culbuteur puente balancín объединить коромысло				1372476 1425513 1425513 1719116 1756382 BK2Q-6K551-BC	<b>50 007 651</b> (4) <b>50 007 653</b> (5)

**F**

					Reference	Item No.		
<b>108</b>	<b>86</b>							
<b>UHFA</b>	10.2007 → 08.2014	D (LA)	4	2198 cm <sup>3</sup>	4V	103 kW (140 PS) 15,5	94,60 mm	
<b>UHFB</b>	10.2007 → 08.2014	D (LA)	4	2198 cm <sup>3</sup>	4V	103 kW (140 PS) 15,5	94,60 mm	
41 252 6..								
	IN [2]	29,8 x 7 x 122,2	S - Cr -	- 30° -	-	22 - III	1121331 1121333 1216915 1217148 1738494 BK2Q 6507 BB XS7Q 6507 A1B XS7Q 6507 A1C XS7Q 6507 A2B XS7Q 6507 A2C	<b>181018</b>
	EX [2]	25,8 x 7 x 122,1	A/S - Cr -	- 45° -	VS -	22 - III	1121332 1132466 1132467 1214456 1376413 1706989 1706990 2S7Q 6505 A1B 2S7Q 6505 A2A 2S7Q 6505 AC BK2Q 6505 BA BK2Q 6505 BB XS7Q 6505 A2B	<b>181019</b>
	[50]	∅ 7 mm						<b>MK-7H</b>
	IN/EX [4]	12,07 x 7.02 x 51,5	G2				XS7Q6510AC	<b>81-18112</b> <small>NEW</small>
	[8]	H 11 x 24,5					6C1Q-6K551-BA	<b>50 007 652</b> (1)
	(1)	nur Ventilstößel only valve tappet seulement poignée de soupape solo manija de válvula только рукоятка клапана						
	[8]						1372476 1425513 1425513 1719116 1756382 BK2Q-6K551-BC	<b>50 007 651</b> (2)
	[1]							<b>50 007 653</b> (3)
	(2)	nur Schleppebel only rocker arm seulement culbuteur solamente palanca de arrastre только балансир						
	(3)	Kipphebelbrücke rocker arm bridge pont de culbuteur puente balancín объединить коромысло						

					Reference	Item No.	
<b>109</b>		<b>86</b>					
<b>CV24</b>		08.2013 → 12.2018	D (LA) 4	2198 cm <sup>3</sup> 4V	114 kW (155 PS)	94,60 mm	
<b>CVRC</b>		10.2011 → 08.2014	D (LA) 4	2198 cm <sup>3</sup> 4V	114 kW (155 PS) 15,5	94,60 mm	
<b>CY14</b>		08.2013 → 12.2018	D (LA) 4	2198 cm <sup>3</sup> 4V	92 kW (125 PS) 15,5	94,60 mm	
<b>CY24</b>		08.2013 → 12.2018	D (LA) 4	2198 cm <sup>3</sup> 4V	92 kW (125 PS) 15,5	94,60 mm	
<b>CYF4</b>		04.2012 → 12.2015	D (LA) 4	2198 cm <sup>3</sup> 4V	92 kW (125 PS) 15,5	94,60 mm	
<b>CYFD</b>		10.2011 → 08.2014	D (LA) 4	2198 cm <sup>3</sup> 4V	92 kW (125 PS) 15,5	94,60 mm	
<b>CYRC</b>		10.2011 → 08.2014	D (LA) 4	2198 cm <sup>3</sup> 4V	92 kW (125 PS) 15,5	94,60 mm	
<b>DRF4</b>		04.2012 → 12.2015	D (LA) 4	2198 cm <sup>3</sup> 4V	74 kW (101 PS) 15,5	94,60 mm	
<b>DRFD</b>		10.2011 → 08.2014	D (LA) 4	2198 cm <sup>3</sup> 4V	74 kW (101 PS) 15,5	94,60 mm	
<b>DRFE</b>		10.2011 → 08.2014	D (LA) 4	2198 cm <sup>3</sup> 4V	74 kW (101 PS) 15,5	94,60 mm	
<b>DRRC</b>		10.2011 → 08.2014	D (LA) 4	2198 cm <sup>3</sup> 4V	74 kW (101 PS) 15,5	94,60 mm	
<b>UHFC</b>		10.2007 → 08.2014	D (LA) 4	2198 cm <sup>3</sup> 4V	103 kW (140 PS) 15,5	94,60 mm	
<b>USF6</b>		08.2013 → 12.2018	D (LA) 4	2198 cm <sup>3</sup> 4V	92 kW (125 PS) 15,5	94,60 mm	
41 252 6.., 41 765 6..							
	IN [2]	29,8 x 7 x 122,2	S - Cr -	- 30° - -	22 - III	1121331 1121333 1216915 1217148 1738494 BK2Q 6507 BB XS7Q 6507 A1B XS7Q 6507 A1C XS7Q 6507 A2B XS7Q 6507 A2C	<b>181018</b>
	EX [2]	25,8 x 7 x 122,1	A/S - Cr -	- 45° - VS -	22 - III	1121332 1132466 1132467 1214456 1376413 1706989 1706990 2S7Q 6505 A1B 2S7Q 6505 A2A 2S7Q 6505 AC BK2Q 6505 BA BK2Q 6505 BB XS7Q 6505 A2B	<b>181019</b>
	[50]	Ø 7 mm					<b>MK-7H</b>
	IN/EX [4]	12,07 x 7.02 x 51,5	G2			XS7Q6510AC	<b>81-18112</b> <small>NEW</small>
<b>110</b>		<b>86</b>					
<b>GBVAJPF</b>		04.2011 →	D (LA) 4	2198 cm <sup>3</sup> 4V	88 kW (120 PS) 15,6	94,60 mm	
<b>GBVAJQJ</b>		04.2011 →	D (LA) 4	2198 cm <sup>3</sup> 4V	110-118 kW (150-160 PS) 15,6	94,60 mm	
<b>GBVAJQW</b>		04.2011 →	D (LA) 4	2198 cm <sup>3</sup> 4V	92 kW (125 PS) 15,5	94,60 mm	
41 765 6..							
	[8]	H 11 x 24,5				6C1Q-6K551-BA	<b>50 007 652</b> (1)
	(1)	nur Ventilstößel only valve tappet seulement poignée de soupape solo manija de válvula только рукоятка клапана					
	[8]					1372476 1425513	<b>50 007 651</b> (2)
	[1]					1425513 1719116 1756382 BK2Q-6K551-BC	<b>50 007 653</b> (3)
Fortsetzung nächste Seite / continued on next page / suite page suivante / continuación página próxima / Продолжение на следующей странице							

					Reference	Item No.
(2)	nur Schleppebel only rocker arm seulement culbuteur solamente palanca de arrastre только балансиры					
(3)	Kipphebelbrücke rocker arm bridge pont de culbuteur puente balancín объединить коромысло					

**F**
**111**
**86**

<b>CVR5</b>	08.2013 → 12.2018	D	(LA)	4	2198 cm <sup>3</sup>	4V	114 kW	(155 PS)	15,5	94,60 mm
<b>CVRA</b>	10.2011 → 08.2014	D	(LA)	4	2198 cm <sup>3</sup>	4V	114 kW	(155 PS)	15,5	94,60 mm
<b>CVRB</b>	10.2011 → 08.2014	D	(LA)	4	2198 cm <sup>3</sup>	4V	114 kW	(155 PS)	15,5	94,60 mm
<b>CYRA</b>	09.2011 → 12.2014	D	(LA)	4	2198 cm <sup>3</sup>	4V	92 kW	(125 PS)	15,5	94,60 mm
<b>CYRB</b>	10.2011 → 08.2014	D	(LA)	4	2198 cm <sup>3</sup>	4V	92 kW	(125 PS)	15,5	94,60 mm
<b>DRR5</b>	08.2013 → 12.2018	D	(A)	4	2198 cm <sup>3</sup>	4V	74 kW	(100 PS)	15,5	94,60 mm
<b>DRRA</b>	10.2011 → 08.2014	D	(LA)	4	2198 cm <sup>3</sup>	4V	74 kW	(101 PS)	15,5	94,60 mm
<b>DRRB</b>	10.2011 → 08.2014	D	(LA)	4	2198 cm <sup>3</sup>	4V	74 kW	(101 PS)	15,5	94,60 mm
<b>UHR5</b>	08.2013 → 12.2018	D	(LA)	4	2198 cm <sup>3</sup>	4V	99 kW	(135 PS)	15,5	94,60 mm
<b>USR6</b>	08.2013 → 12.2018	D	(LA)	4	2198 cm <sup>3</sup>	4V	92 kW	(125 PS)	15,5	94,60 mm
<b>USRA</b>	09.2011 → 08.2014	D	(LA)	4	2198 cm <sup>3</sup>	4V	100 kW	(136 PS)	15,5	94,60 mm
<b>USRB</b>	09.2011 → 08.2014	D	(LA)	4	2198 cm <sup>3</sup>	4V	100 kW	(136 PS)	15,5	94,60 mm
<b>UYR6</b>	08.2013 → 12.2018	D	(LA)	4	2198 cm <sup>3</sup>	4V	114 kW	(155 PS)	15,5	94,60 mm

41 252 6.., 41 765 6..

	IN [2]	29,8 x 7 x 122,2	S - Cr -	- 30° -	-	22 - III	1121331 1121333 1216915 1217148 1738494 BK2Q 6507 BB XS7Q 6507 A1B XS7Q 6507 A1C XS7Q 6507 A2B XS7Q 6507 A2C	<b>181018</b>
	EX [2]	25,8 x 7 x 122,1	A/S - Cr -	- 45° -	VS -	22 - III	1121332 1132466 1132467 1214456 1376413 1706989 1706990 2S7Q 6505 A1B 2S7Q 6505 A2A 2S7Q 6505 AC BK2Q 6505 BA BK2Q 6505 BB XS7Q 6505 A2B	<b>181019</b>
	[50]	∅ 7 mm						<b>MK-7H</b>
	IN/EX [4]	12,07 x 7.02 x 51,5	G2				XS7Q6510AC	<b>81-18112</b> <small>NEW</small>
	AS						1731706 BK2Q-6A273-AB	<b>50 007 686</b> (1)
	ES						1372743 1545160 1704531 BK3Q-6A270-AA	<b>50 007 687</b> (1)
	(1)	Schalenhartguss/chilled cast iron/pièce moulée trempée en surface/fundición en coquilla/Отливка с отбеленным поверхностным слоем						

Fortsetzung nächste Seite / continued on next page / suite page suivante / continuación página próxima / Продолжение на следующей странице



					Reference	Item No.
[8]	H 11 x 24,5				6C1Q-6K551-BA	<b>50 007 652</b> (2)
	(2) nur Ventilstößel only valve tappet seulement poignée de soupape solo manija de válvula только рукоятка клапана					
[8]					1372476 1425513	<b>50 007 651</b> (3)
[1]					1425513 1719116 1756382 BK2Q-6K551-BC	<b>50 007 653</b> (4)
	(3) nur Schleppebel only rocker arm seulement culbuteur solamente palanca de arrastre только балансир					
	(4) Kipphebelbrücke rocker arm bridge pont de culbuteur puente balancín объединить коромысло					

**112**

**86**

**CYR5** 08.2013 → 12.2018 D (A) 4 2198 cm<sup>3</sup> 4V 92 kW (125 PS) 15,5 94,60 mm

	AS				1731706 BK2Q-6A273-AB	<b>50 007 686</b> (1)
	ES				1372743 1545160 1704531 BK3Q-6A270-AA	<b>50 007 687</b> (1)
	(1) Schalenhartguss/chilled cast iron/pièce moulée trempée en surface/fundición en coquilla/Отливка с отбеленным поверхностным слоем					
[8]	H 11 x 24,5				6C1Q-6K551-BA	<b>50 007 652</b> (2)
	(2) nur Ventilstößel only valve tappet seulement poignée de soupape solo manija de válvula только рукоятка клапана					
[8]					1372476 1425513	<b>50 007 651</b> (3)
[1]					1425513 1719116 1756382 BK2Q-6K551-BC	<b>50 007 653</b> (4)
	(3) nur Schleppebel only rocker arm seulement culbuteur solamente palanca de arrastre только балансир					
	(4) Kipphebelbrücke rocker arm bridge pont de culbuteur puente balancín объединить коромысло					

					<b>Reference</b>	<b>Item No.</b>
--	--	--	--	--	------------------	-----------------

## 113 86,2

<b>REB</b>	10.1984 → 12.1986	B	(NA)	4	1796 cm <sup>3</sup>	2V	66 kW	(90 PS)	9,5	77,00 mm
<b>REC</b>	04.1985 → 02.1992	B	(NA)	4	1796 cm <sup>3</sup>	2V	66 kW	(90 PS)	9,5	77,00 mm
<b>RED</b>	10.1987 → 09.1989	B	(NA)	4	1796 cm <sup>3</sup>	2V	59-66 kW	(80-90 PS)	9,5	77,00 mm
<b>REF</b>	10.1987 → 09.1989	B	(NA)	4	1796 cm <sup>3</sup>	2V	59 kW	(80 PS)	9,5	77,00 mm

93 754 6..

	IN/EX [4]	12,76 x 7.91 x 38,0	G1							<b>81-5801</b>
							1584660	78HM 6250 BA		<b>50 006 257</b> (1)
									(1) Schalenhartguss/chilled cast iron/pièce moulée trempée en surface/fundición en coquilla/Отливка с отбеленным поверхностным слоем	
	EX [4]						6062845	78HM6564AA		<b>50 007 624</b>

## 114 86,2

<b>R2A</b>	01.1987 → 05.1988	B	(NA)	4	1796 cm <sup>3</sup>	2V	66 kW	(90 PS)	9,5	77,00 mm
------------	-------------------	---	------	---	----------------------	----	-------	---------	-----	----------

	[50]	Ø 8 mm								<b>MK-8H</b>
	IN/EX [4]	13,57 x 8 x 67,9	G1				81SM 6510 LC			<b>81-18104</b>
	EX [4]						6062845	78HM6564AA		<b>50 007 624</b>

## 115 87,5

<b>AOBA Euro 4</b>	03.2007 → 01.2015	B	(NA)	4	1999 cm <sup>3</sup>	4V	107 kW	(145 PS)	10,8	83,10 mm
<b>AOBC</b>	03.2007 → 01.2015	B	(NA)	4	1999 cm <sup>3</sup>	4V	107 kW	(145 PS)		83,10 mm
<b>AODA</b>	03.2004 → 09.2012	B	(NA)	4	1999 cm <sup>3</sup>	4V	107 kW	(145 PS)	10,8	83,10 mm
<b>AODB</b>	03.2004 → 09.2012	B	(NA)	4	1999 cm <sup>3</sup>	4V	107 kW	(145 PS)	10,8	83,10 mm
<b>AODE</b>	03.2004 → 12.2014	B	(NA)	4	1999 cm <sup>3</sup>	4V	104-107 kW	(141-145 PS)	10,8	83,10 mm
<b>AOWA</b>	05.2006 → 06.2015	B	(NA)	4	1999 cm <sup>3</sup>	4V	107 kW	(145 PS)	10,8	83,10 mm
<b>AOWB</b>	05.2006 → 06.2015	B	(NA)	4	1999 cm <sup>3</sup>	4V	107 kW	(145 PS)	10,8	83,10 mm
<b>CJBA</b>	10.2000 → 03.2007	B	(NA)	4	1999 cm <sup>3</sup>	4V	106-107 kW	(144-146 PS)	10,8	83,10 mm
<b>CJBB</b>	10.2000 → 03.2007	B	(NA)	4	1999 cm <sup>3</sup>	4V	107 kW	(146 PS)	10,8	83,10 mm
<b>GZ</b>	03.2004 →	B	(NA)	4	2261 cm <sup>3</sup>	4V	108-114 kW	(147-155 PS)	9,7	94,00 mm
<b>N4JB</b>	03.2005 → 06.2008	B	(NA)	4	1999 cm <sup>3</sup>	4V	110 kW	(150 PS)	10,8	83,10 mm
<b>SEBA</b>	07.2007 → 01.2015	B	(NA)	4	2261 cm <sup>3</sup>	4V	118 kW	(160 PS)		94,00 mm
<b>SYDA</b>	03.2004 → 09.2013	B	(NA)	4	1999 cm <sup>3</sup>	4V	104-109 kW	(143-146 PS)	10,8:1	83,10 mm
<b>TBBA Euro 4</b>	03.2007 → 01.2015	B	(NA)	4	1999 cm <sup>3</sup>	4V	107 kW	(145 PS)	10,8	83,10 mm
<b>TBBB</b>	03.2007 → 01.2015	B	(NA)	4	1999 cm <sup>3</sup>	4V	107 kW	(145 PS)		83,10 mm

99 457 6..

Fortsetzung nächste Seite / continued on next page / suite page suivante / continuación página próxima / Продолжение на следующей странице

					Reference	Item No.
	IN [2] 35,0 x 5,5 x 103,5	S - Ni -	- 45° - -	1 -	1124378 1213175 1324132 1374186 1584022 1S7G 6507 C7G 1S7G 6507 CE 1S7G 6507 CF 1S7G 6507 CG 6C1G 6507 AA	<b>181108</b>
	EX [2] 30,0 x 5,5 x 104,7	A - Ni -	- 45° - -	1 -	1124377 1124619 1324131 1584019 1S7G 6505 C7F 1S7G 6505 CE 1S7G 6505 CF 5155405 9S4E 6505 AB	<b>181109</b>

<b>116</b> <b>87,65</b>						
LCN	01.1978 → 04.1987	B (NA)	4	1593 cm <sup>3</sup>	2V	54 kW (73 PS) 9,2 66,00 mm
	IN [2] 42,0 x 8 x 111,2	S - -	- 45° - -	22 - III	70HM 6507 DD	<b>7837</b>
	EX [2] 36,0 x 8 x 110,6	A/S - Cr -	- 45° - -	22 - III	70HM 6505 DE	<b>7885</b>
	[50]	Ø 8 mm				<b>MK-8H</b>
	IN/EX [4] 12,76 x 8.06 x 60,3	G1				<b>81-18110</b>
	EX [4]				6062845 78HM6564AA	<b>50 007 624</b>

<b>117</b> <b>87,68</b>						
LCE	02.1974 → 1988	B (NA)	4	1593 cm <sup>3</sup>	2V	53 kW (72 PS) 9,2 66,00 mm
	IN [2] 42,0 x 8 x 111,2	S - -	- 45° - -	22 - III	70HM 6507 DD	<b>7837</b>
	EX [2] 36,0 x 8 x 110,6	A/S - Cr -	- 45° - -	22 - III	70HM 6505 DE	<b>7885</b>
	[50]	Ø 8 mm				<b>MK-8H</b>
	IN/EX [4] 12,76 x 8.06 x 60,3	G1				<b>81-18110</b>
	EX [4]				6062845 78HM6564AA	<b>50 007 624</b>

<b>118</b> <b>87,68</b>						
4RB	12.1977 → 04.1981	B (NA)	4	1593 cm <sup>3</sup>	2V	48 kW (65 PS) 8 66,00 mm
B	11.1977 → 10.1986	B (NA)	4	1593 cm <sup>3</sup>	2V	48 kW (65 PS) 8 66,00 mm
	IN [2] 42,0 x 8 x 111,2	S - -	- 45° - -	22 - III	70HM 6507 DD	<b>7837</b>
	EX [2] 36,0 x 8 x 110,6	A/S - Cr -	- 45° - -	22 - III	70HM 6505 DE	<b>7885</b>
	[50]	Ø 8 mm				<b>MK-8H</b>
	IN/EX [4] 12,76 x 8.06 x 60,3	G1				<b>81-18110</b>
					6062844 78HM 6250 AA	<b>50 006 260</b>

					Reference	Item No.	
<b>119</b>	<b>87,7</b>						
<b>LCR</b>	04.1982 → 09.1987	B (NA)	4	1598 cm <sup>3</sup> 2V	54 kW (73 PS) 9,5:1	66,00 mm	
	IN [2] EX [2]	42,0 x 8 x 111,2 36,0 x 8 x 110,6	S - - A/S - Cr -	- 45° - - - 45° - -	22 - III 22 - III	70HM 6507 DD 70HM 6505 DE	<b>7837</b> <b>7885</b>
	[50]	∅ 8 mm					<b>MK-8H</b>
	IN/EX [4]	12,76 x 8.06 x 60,3	G1				<b>81-18110</b>
	EX [4]				6062845 78HM6564AA		<b>50 007 624</b>
<b>120</b>	<b>88</b>						
<b>VTA</b>	08.1977 → 06.1979	D	4	1948 cm <sup>3</sup> 2V	37 kW (50 PS) 21,8:1	80,00 mm	
92 791 6..							
	[50]	∅ 8 mm					<b>KK-8H</b>
	IN/EX [4]	14,05 x 8.5 x 55,0	G1				<b>81-5303</b>
<b>121</b>	<b>89,9</b>						
<b>D2FA</b>	01.2000 → 05.2006	D (LA)	4	2402 cm <sup>3</sup> 4V	66 kW (90 PS) 19	94,60 mm	
<b>D2FB</b>	01.2000 → 05.2006	D (LA)	4	2402 cm <sup>3</sup> 4V	66 kW (90 PS) 19	94,60 mm	
<b>D4FA</b>	01.2000 → 05.2006	D (LA)	4	2402 cm <sup>3</sup> 4V	88 kW (120 PS) 19	94,60 mm	
<b>DOFA</b>	07.2001 → 05.2006	D (LA)	4	2402 cm <sup>3</sup> 4V	92 kW (125 PS) 18,5	94,60 mm	
<b>FXFA</b>	03.2004 → 05.2006	D (LA)	4	2402 cm <sup>3</sup> 4V	85 kW (115 PS) 19	94,60 mm	
40 171 6.., 40 172 6..							
	IN [2]	31,3 x 7 x 122,2	S - Cr -	- 30° - -	22 - III	1096250 1254284 YC1Q 6507 A1B YC1Q 6507 A2B	<b>181016</b>
	[50]	∅ 7 mm					<b>MK-7H</b>
	ES					1349549 1688419 4C1Q 6A270 AC 4C1Q-6A270-AB	<b>50 007 101</b> <small>NEW</small>
	AS					1349547 4C1Q 6A273 AB	<b>50 007 102</b> <small>NEW</small>
	[4]					1100013 YC1Q6K528A1D	<b>50 007 608</b> (1)
	[4]					1099936 YC1Q6529A1D	<b>50 007 609</b> (2)
	(1) short						
	(2) long						
<b>122</b>	<b>89,9</b>						
<b>D2FE</b>	01.2000 → 05.2006	D (LA)	4	2402 cm <sup>3</sup> 4V	66 kW (90 PS) 19	94,60 mm	
40 171 6..							
	IN [2]	31,3 x 7 x 122,2	S - Cr -	- 30° - -	22 - III	1096250 1254284 YC1Q 6507 A1B YC1Q 6507 A2B	<b>181016</b>
	[50]	∅ 7 mm					<b>MK-7H</b>

					Reference	Item No.	
<b>123</b> <b>89,9</b>							
<b>F4FA</b> 40 171 6..	01.2000 → 05.2006	D	(LA)	4	2402 cm <sup>3</sup> 4V	55 kW (75 PS) 19 94,60 mm	
	IN [2]	31,3 x 7 x 122,2	S - Cr -	- 30° - -	22 - III	1096250 1254284 YC1Q 6507 A1B YC1Q 6507 A2B	<b>181016</b>
	[50]	Ø 7 mm					<b>MK-7H</b>
	ES					1349549 1688419 4C1Q 6A270 AC 4C1Q-6A270-AB	<b>50 007 101</b> <small>NEW</small>
	AS					1349547 4C1Q 6A273 AB	<b>50 007 102</b> <small>NEW</small>
<b>124</b> <b>89,9</b>							
<b>H9FA Euro 4</b> 40 739 6.., 40 830 6..	03.2004 → 05.2006	D	(LA)	4	2402 cm <sup>3</sup> 4V	101 kW (137 PS) 18 94,60 mm	
	IN [2]	29,8 x 7 x 122,2	S - Cr -	- 30° - -	22 - III	1121331 1121333 1216915 1217148 1738494 BK2Q 6507 BB XS7Q 6507 A1B XS7Q 6507 A1C XS7Q 6507 A2B XS7Q 6507 A2C	<b>181018</b>
	IN [2]	31,3 x 7 x 122,2	S - Cr -	- 30° - -	22 - III	1096250 1254284 YC1Q 6507 A1B YC1Q 6507 A2B	<b>181016</b>
	EX [2]	25,8 x 7 x 122,1	A/S - Cr -	- 45° - VS -	22 - III	1121332 1132466 1132467 1214456 1376413 1706989 1706990 2S7Q 6505 A1B 2S7Q 6505 A2A 2S7Q 6505 AC BK2Q 6505 BA BK2Q 6505 BB XS7Q 6505 A2B	<b>181019</b>
	[50]	Ø 7 mm					<b>MK-7H</b>
	IN/EX [4]	12,07 x 7.02 x 51,5	G2			XS7Q6510AC	<b>81-18112</b> <small>NEW</small>
	ES					1349549 1688419 4C1Q 6A270 AC 4C1Q-6A270-AB	<b>50 007 101</b> <small>NEW</small>
	AS					1349547 4C1Q 6A273 AB	<b>50 007 102</b> <small>NEW</small>
Fortsetzung nächste Seite / continued on next page / suite page suivante / continuación página próxima / Продолжение на следующей странице							

**F**



					Reference	Item No.
[4]					1100013	<b>50 007 608</b> (1)
[4]					YC1Q6K528A1D	<b>50 007 609</b> (2)
(1) short					1099936	
(2) long					YC1Q6529A1D	

**125**
**89,9**
**H9FB Euro 4**

04.2006 → 08.2014

D

(LA)

4

 2402 cm<sup>3</sup> 4V

103 kW

(140 PS) 18

94,60 mm

40 830 6..

**F**

IN [2]	29,8 x 7 x 122,2	S - Cr -	- 30° - -	22 - III	1121331 1121333 1216915 1217148 1738494 BK2Q 6507 BB XS7Q 6507 A1B XS7Q 6507 A1C XS7Q 6507 A2B XS7Q 6507 A2C	<b>181018</b>
EX [2]	25,8 x 7 x 122,1	A/S - Cr -	- 45° - VS -	22 - III	1121332 1132466 1132467 1214456 1376413 1706989 1706990 2S7Q 6505 A1B 2S7Q 6505 A2A 2S7Q 6505 AC BK2Q 6505 BA BK2Q 6505 BB XS7Q 6505 A2B	<b>181019</b>
[50]	Ø 7 mm					<b>MK-7H</b>
IN/EX [4]	12,07 x 7.02 x 51,5	G2			XS7Q6510AC	<b>81-18112</b>
[8]	H 11 x 24,5				6C1Q-6K551-BA	<b>50 007 652</b> (1)
(1)	nur Ventilstößel only valve tappet seulement poignée de soupape solo manija de válvula только рукоятка клапана					
[8]					1372476 1425513	<b>50 007 651</b> (2)
[1]					1425513 1719116 1756382 BK2Q-6K551-BC	<b>50 007 653</b> (3)
(2)	nur Schleppebel only rocker arm seulement culbuteur solamente palanca de arrastre только балансир					
(3)	Kipphebelbrücke rocker arm bridge pont de culbuteur puente balancín объединить коромысло					

					Reference	Item No.	
<b>126</b>		<b>89,9</b>					
<b>H9FD</b>	04.2006 → 08.2014	D	(LA)	4	2402 cm <sup>3</sup> 4V	103 kW (140 PS) 18	94,60 mm
	IN [2]	29,8 x 7 x 122,2	S - Cr -	- 30° - -	22 - III	1121331 1121333 1216915 1217148 1738494 BK2Q 6507 BB XS7Q 6507 A1B XS7Q 6507 A1C XS7Q 6507 A2B XS7Q 6507 A2C	<b>181018</b>
	IN [2]	31,3 x 7 x 122,2	S - Cr -	- 30° - -	22 - III	1096250 1254284 YC1Q 6507 A1B YC1Q 6507 A2B	<b>181016</b>
	EX [2]	25,8 x 7 x 122,1	A/S - Cr -	- 45° - VS -	22 - III	1121332 1132466 1132467 1214456 1376413 1706989 1706990 2S7Q 6505 A1B 2S7Q 6505 A2A 2S7Q 6505 AC BK2Q 6505 BA BK2Q 6505 BB XS7Q 6505 A2B	<b>181019</b>
	[50]	Ø 7 mm					<b>MK-7H</b>
	IN/EX [4]	12,07 x 7.02 x 51,5	G2			XS7Q6510AC	<b>81-18112</b>
	AS					1372744 6C1Q6A273BB	<b>50 007 028</b> (1)
	(1)	Schalenhartguss/chilled cast iron/pièce moulée trempée en surface/fundición en coquilla/Отливка с отбеленным поверхностным слоем					
	[8]	H 11 x 24,5				6C1Q-6K551-BA	<b>50 007 652</b> (2)
	(2)	nur Ventilstößel only valve tappet seulement poignée de soupape solo manija de válvula только рукоятка клапана					
	[8]					1372476 1425513	<b>50 007 651</b> (3)
	[1]					1425513 1719116 1756382 BK2Q-6K551-BC	<b>50 007 653</b> (4)
	(3)	nur Schleppebel only rocker arm seulement culbuteur solamente palanca de arrastre только баланси́р					
	(4)	Kipphebelbrücke rocker arm bridge pont de culbuteur puente balancín объединить коромысло					

**F**

					Reference	Item No.
--	--	--	--	--	-----------	----------

## 127 89,9

<b>JXFA Euro 4</b>	04.2006 → 08.2014	D (LA)	4	2402 cm <sup>3</sup>	4V	85 kW	(115 PS)	18	94,60 mm
<b>JXFC</b>	04.2006 → 08.2014	D (LA)	4	2402 cm <sup>3</sup>	4V	85 kW	(115 PS)	18	94,60 mm
<b>PHFA Euro 4</b>	04.2006 → 08.2014	D (LA)	4	2402 cm <sup>3</sup>	4V	74 kW	(100 PS)	18	94,60 mm
<b>PHFC Euro 4</b>	04.2006 → 08.2014	D (LA)	4	2402 cm <sup>3</sup>	4V	74 kW	(100 PS)	18	94,60 mm

40 830 6..., 41 285 6..

	IN [2]	31,3 x 7 x 122,2	S - Cr -	- 30° -	-	22 - III	1096250 1254284 YC1Q 6507 A1B YC1Q 6507 A2B	<b>181016</b>
	[50]	Ø 7 mm						<b>MK-7H</b>
		AS					1372744 6C1Q6A273BB	<b>50 007 028</b> (1)
		(1) Schalenhartguss/chilled cast iron/pièce moulée trempée en surface/fundición en coquilla/Отливка с отбелнным поверхностным слоем						
	[8]	H 11 x 24,5					6C1Q-6K551-BA	<b>50 007 652</b> (2)
		(2) nur Ventilstößel only valve tappet seulement poignée de soupape solo manija de válvula только рукоятка клапана						
	[8]						1372476 1425513 1425513 1719116 1756382 BK2Q-6K551-BC	<b>50 007 651</b> (3)
	[1]							<b>50 007 653</b> (4)
		(3) nur Schleppebel only rocker arm seulement culbuteur solamente palanca de arrastre только баланси́р						
		(4) Kipphebelbrücke rocker arm bridge pont de culbuteur puente balancín объединить коромысло						

## 128 89,9

<b>SAFA</b>	09.2007 →	D (LA)	5	3198 cm <sup>3</sup>	4V	147 kW	(200 PS)	15,7	100,76 mm
<b>SAFB</b>	09.2007 → 08.2014	D (LA)	5	3199 cm <sup>3</sup>	4V	147 kW	(200 PS)		100,76 mm

Fortsetzung nächste Seite / continued on next page / suite page suivante / continuación página próxima / Продолжение на следующей странице

					Reference	Item No.
	IN [2] 29,8 x 7 x 122,2	S - Cr -	- 30° - -	22 - III	1121331 1121333 1216915 1217148 1738494 BK2Q 6507 BB XS7Q 6507 A1B XS7Q 6507 A1C XS7Q 6507 A2B XS7Q 6507 A2C	<b>181018</b>
	EX [2] 25,8 x 7 x 122,1	A/S - Cr -	- 45° - VS -	22 - III	1121332 1132466 1132467 1214456 1376413 1706989 1706990 2S7Q 6505 A1B 2S7Q 6505 A2A 2S7Q 6505 AC BK2Q 6505 BA BK2Q 6505 BB XS7Q 6505 A2B	<b>181019</b>
	[50] Ø 7 mm					<b>MK-7H</b>
	IN/EX [4] 12,07 x 7.02 x 51,5	G2			XS7Q6510AC	<b>81-18112</b> <small>NEW</small>
<b>129</b>		<b>90</b>				
<b>MY</b>	07.1967 → 07.1981	B (NA)	4	1699 cm <sup>3</sup> 2V	51-55 kW (69-75 PS)	8,75:1 66,80 mm
<b>MYE</b>	08.1977 → 07.1981	B (NA)	4	1699 cm <sup>3</sup> 2V	54 kW (74 PS)	8,75:1 66,80 mm
	IN [2] 42,0 x 8 x 111,2	S - -	- 45° - -	22 - III	70HM 6507 DD	<b>7837</b>
	EX [2] 36,0 x 8 x 110,6	A/S - Cr -	- 45° - -	22 - III	70HM 6505 DE	<b>7885</b>
	[50] Ø 8 mm					<b>MK-8H</b>
	IN/EX [4] 12,76 x 8.06 x 60,3	G1				<b>81-18110</b>
					6062844 78HM 6250 AA	<b>50 006 260</b>
<b>130</b>		<b>90,8</b>				
<b>NE</b>	01.1972 → 08.1980	B (NA)	4	1993 cm <sup>3</sup> 2V	73-80 kW (99-110 PS)	9,2 77,00 mm
	90 606 6..					
	IN [2] 42,0 x 8 x 111,2	S - -	- 45° - -	22 - III	70HM 6507 DD	<b>7837</b>
	EX [2] 36,0 x 8 x 110,6	A/S - Cr -	- 45° - -	22 - III	70HM 6505 DE	<b>7885</b>
	[50] Ø 8 mm					<b>MK-8H</b>
	IN/EX [4] 12,76 x 8.06 x 60,3	G1				<b>81-18110</b>
					6062844 78HM 6250 AA	<b>50 006 260</b>
	EX [4]				6062845 78HM6564AA	<b>50 007 624</b>

**F**

					Reference	Item No.	
<b>131</b>	<b>90,8</b>						
<b>N4B</b>	01.1987 → 02.1993	B (NA)	4	1993 cm <sup>3</sup>	2V	74 kW (100 PS) 8,5	77,00 mm
<b>NE5</b>	01.1987 → 02.1993	B (NA)	4	1993 cm <sup>3</sup>	2V	74 kW (100 PS) 9,2	77,00 mm
<b>NEE</b>	08.1973 → 02.1976	B (NA)	4	1993 cm <sup>3</sup>	2V	72 kW (98 PS) 9,2	77,00 mm
<b>NEG</b>	08.1973 → 07.1979	B (NA)	4	1993 cm <sup>3</sup>	2V	70-73 kW (95-99 PS) 9,2	77,00 mm
<b>NEJ</b>	01.1987 → 02.1993	B (NA)	4	1993 cm <sup>3</sup>	2V	74 kW (100 PS) 9,2	77,00 mm
<b>NES</b>	01.1987 → 12.1989	B (NA)	4	1993 cm <sup>3</sup>	2V	77 kW (105 PS) 10,3	77,00 mm
90 606 6..							
	IN [2] EX [2]	42,0 x 8 x 111,2 36,0 x 8 x 110,6	S - - A/S - Cr -	- 45° - - - 45° - -	22 - III 22 - III	70HM 6507 DD 70HM 6505 DE	<b>7837</b> <b>7885</b>
	[50]	∅ 8 mm					<b>MK-8H</b>
	IN/EX [4]	12,76 x 8.06 x 60,3	G1				<b>81-18110</b>
						1584660 78HM 6250 BA	<b>50 006 257</b> (1)
							(1) Schalenhartguss/chilled cast iron/pièce moulée trempée en surface/fundición en coquilla/Отливка с отбелсным поверхностным слоем
	EX [4]					6062845 78HM6564AA	<b>50 007 624</b>
<b>132</b>	<b>90,8</b>						
<b>N6T</b>	11.1985 → 09.1992	B (NA)	4	1993 cm <sup>3</sup>	2V	57 kW (78 PS) 8,6:1	77,00 mm
<b>NAT</b>	09.1985 → 12.1999	B (NA)	4	1994 cm <sup>3</sup>	2V	57 kW (78 PS) 8	76,95 mm
<b>NBA</b>	04.1991 → 09.1994	B (NA)	4	1993 cm <sup>3</sup>	2V	66 kW (90 PS) 8;5:1	77,00 mm
	IN [2] EX [2]	42,0 x 8 x 111,2 36,0 x 8 x 110,6	S - - A/S - Cr -	- 45° - - - 45° - -	22 - III 22 - III	70HM 6507 DD 70HM 6505 DE	<b>7837</b> <b>7885</b>
	[50]	∅ 8 mm					<b>MK-8H</b>
	IN/EX [4]	12,76 x 8.06 x 60,3	G1				<b>81-18110</b>
						6062844 78HM 6250 AA	<b>50 006 260</b>
<b>133</b>	<b>90,8</b>						
<b>NCA</b>	09.1991 → 08.1994	B (NA)	4	1994 cm <sup>3</sup>	2V	72 kW (98 PS) 8,5:1	77,00 mm
	[50]	∅ 7 mm					<b>MK-7H</b>
	IN/EX [4]	13,55 x 7.05 x 43,0	G1			6172956	<b>81-17100</b>
						1584660 78HM 6250 BA	<b>50 006 257</b> (1)
							(1) Schalenhartguss/chilled cast iron/pièce moulée trempée en surface/fundición en coquilla/Отливка с отбелсным поверхностным слоем
	EX [4]					6062845 78HM6564AA	<b>50 007 624</b>



					Reference	Item No.	
<b>134</b>		<b>90,83</b>					
<b>4RC</b>		12.1977 → 10.1986	B (NA) 4	1993 cm <sup>3</sup> 2V	43-57 kW (59-78 PS) 8	77,00 mm	
<b>C</b>			B (K) 4	1993 cm <sup>3</sup> 2V	43-55 kW (59-75 PS) 8:1	77,00 mm	
<b>MC</b>			B 4	1993 cm <sup>3</sup> 2V	75 kW (101 PS) 8,5:1	76,95 mm	
<b>NAV</b>		09.1985 → 09.1992	B (NA) 4	1994 cm <sup>3</sup> 2V	55-57 kW (75-78 PS) 8	76,95 mm	
	IN [2] EX [2]	42,0 x 8 x 111,2 36,0 x 8 x 110,6	S - - A/S - Cr -	- 45° - - - 45° - -	22 - III 22 - III	70HM 6507 DD 70HM 6505 DE	<b>7837</b> <b>7885</b>
	[50]	∅ 8 mm					<b>MK-8H</b>
	IN/EX [4]	12,76 x 8.06 x 60,3	G1				<b>81-18110</b>
						6062844 78HM 6250 AA	<b>50 006 260</b>
<b>135</b>		<b>90,83</b>					
<b>N4A</b>		01.1987 → 02.1993	B (NA) 4	1993 cm <sup>3</sup> 2V	85 kW (115 PS) 9,2	77,00 mm	
<b>N4I</b>		01.1987 → 02.1993	B (NA) 4	1993 cm <sup>3</sup> 2V	85 kW (115 PS) 9,2	77,00 mm	
<b>NEL</b>		04.1985 → 08.1989	B (NA) 4	1993 cm <sup>3</sup> 2V	77 kW (105 PS) 9,2	77,00 mm	
<b>NEN</b>		01.1978 → 12.1985	B (NA) 4	1993 cm <sup>3</sup> 2V	73-74 kW (99-101 PS) 9,2	77,00 mm	
<b>NEP</b>		08.1979 → 08.1985	B (NA) 4	1993 cm <sup>3</sup> 2V	74-77 kW (101-105 PS) 9,2	77,00 mm	
<b>NER</b>		07.1979 → 07.1982	B (NA) 4	1993 cm <sup>3</sup> 2V	64-74 kW (100 PS) 9,2	77,00 mm	
<b>NET</b>		08.1982 → 12.1986	B (NA) 4	1993 cm <sup>3</sup> 2V	74-77 kW (101-105 PS) 9,2	77,00 mm	
<b>NR2</b>		03.1985 → 12.1986	B (NA) 4	1993 cm <sup>3</sup> 2V	85 kW (115 PS) 9,2	77,00 mm	
<b>NRA</b>		04.1985 → 09.1994	B (NA) 4	1993 cm <sup>3</sup> 2V	85 kW (115 PS) 9,2	77,00 mm	
<b>NRB</b>		03.1985 → 12.1986	B (NA) 4	1993 cm <sup>3</sup> 2V	85 kW (115 PS) 9,2	77,00 mm	
<b>NRC</b>		10.1985 → 12.1990	B (NA) 4	1993 cm <sup>3</sup> 2V	74 kW (100 PS) 8,5	77,00 mm	
<b>NRD</b>		10.1985 → 12.1986	B (NA) 4	1993 cm <sup>3</sup> 2V	74 kW (100 PS) 8,5	77,00 mm	
<b>NRI</b>		04.1985 → 09.1994	B (NA) 4	1993 cm <sup>3</sup> 2V	85 kW (115 PS) 9,2	77,00 mm	
90 606 6..							
	IN [2] EX [2]	42,0 x 8 x 111,2 36,0 x 8 x 110,6	S - - A/S - Cr -	- 45° - - - 45° - -	22 - III 22 - III	70HM 6507 DD 70HM 6505 DE	<b>7837</b> <b>7885</b>
	[50]	∅ 8 mm					<b>MK-8H</b>
	IN/EX [4]	12,76 x 8.06 x 60,3	G1				<b>81-18110</b>
						1584660 78HM 6250 BA	<b>50 006 257</b> (1)
(1) Schalenhartguss/chilled cast iron/pièce moulée trempée en surface/fundición en coquilla/Отливка с отбелсным поверхностным слоем							
	EX [4]					6062845 78HM6564AA	<b>50 007 624</b>
<b>136</b>		<b>90,83</b>					
<b>NEK</b>		08.1981 → 08.1985	B (NA) 4	1993 cm <sup>3</sup> 2V	74-77 kW (101-105 PS) 9,2	77,00 mm	
90 606 6..							
	IN [2] EX [2]	42,0 x 8 x 111,2 36,0 x 8 x 110,6	S - - A/S - Cr -	- 45° - - - 45° - -	22 - III 22 - III	70HM 6507 DD 70HM 6505 DE	<b>7837</b> <b>7885</b>
	[50] [50]	∅ 7 mm ∅ 8 mm					<b>MK-7H</b> <b>MK-8H</b>
	IN/EX [4] IN/EX [4]	12,76 x 8.06 x 60,3 13,55 x 7.05 x 43,0	G1 G1			6172956	<b>81-18110</b> <b>81-17100</b>
Fortsetzung nächste Seite / continued on next page / suite page suivante / continuación página próxima / Продолжение на следующей странице							

**F**

					Reference	Item No.		
					6062844 78HM 6250 AA	<b>50 006 260</b>		
EX [4]					6062845 78HM6564AA	<b>50 007 624</b>		
<b>137</b>		<b>90,83</b>						
<b>NAE</b>	10.1987 → 12.1992	B	(NA)	4	1993 cm <sup>3</sup> 2V	57 kW (78 PS) 8	76,95 mm	
IN [2]	42,0 x 8 x 111,2	S	-	-	- 45° -	22 - III	70HM 6507 DD	<b>7837</b>
EX [2]	36,0 x 8 x 110,6	A/S	-	Cr -	- 45° -	22 - III	70HM 6505 DE	<b>7885</b>
[50]	∅ 8 mm							<b>MK-8H</b>
IN/EX [4]	12,76 x 8.06 x 60,3	G1						<b>81-18110</b>
					6062844 78HM 6250 AA		<b>50 006 260</b>	
EX [4]					6062845 78HM6564AA		<b>50 007 624</b>	
<b>138</b>		<b>93</b>						
<b>BRC</b>	09.1986 → 09.1994	B	(NA)	6	2933 cm <sup>3</sup> 2V	110 kW (150 PS) 9,5	72,00 mm	
IN/EX [4]	12,08/15 x 7 x 36,5	B1						<b>81-33103</b>
<b>139</b>		<b>93</b>						
<b>BRT</b>	01.1991 → 09.1994	B	(NA)	6	2935 cm <sup>3</sup> 2V	104-107 kW (141-145 PS) 9,5	72,00 mm	
IN/EX [4]	12,07 x 7 x 31,5	B1						<b>81-33115</b> <small>NEW</small>
<b>140</b>		<b>93,67</b>						
<b>4BA</b>	09.1988 → 09.1992	D	(NA)	4	2496 cm <sup>3</sup> 2V	52 kW (71 PS) 19,5	90,50 mm	
<b>4DA</b>	05.1991 → 08.1994	D	(NA)	4	2496 cm <sup>3</sup> 2V	59 kW (80 PS) 20,6	90,54 mm	
<b>4EA</b>	05.1991 → 08.1994	D	(A)	4	2496 cm <sup>3</sup> 2V	74 kW (100 PS) 18,3	90,50 mm	
<b>4ED</b>	08.1997 → 03.2000	D	(A)	4	2496 cm <sup>3</sup> 2V	85 kW (116 PS) 18	90,54 mm	
<b>4GA</b>	10.1992 → 12.2000	D	(A)	4	2496 cm <sup>3</sup> 2V	63 kW (85 PS) 20,6	90,54 mm	
<b>4GB</b>	06.1994 → 12.2000	D	(A)	4	2496 cm <sup>3</sup> 2V	63 kW (85 PS) 20,6	90,54 mm	
<b>4GC</b>	06.1994 → 12.2000	D	(A)	4	2496 cm <sup>3</sup> 2V	63 kW (85 PS) 20,6	90,54 mm	
<b>4GD</b>	06.1994 → 12.2000	D	(A)	4	2496 cm <sup>3</sup> 2V	63 kW (86 PS) 20,6	90,54 mm	
<b>4HA</b>	08.1994 → 06.2000	D	(NA)	4	2496 cm <sup>3</sup> 2V	55-56 kW (75-76 PS) 20,6	90,54 mm	
<b>4HB</b>	06.1994 → 12.2000	D	(NA)	4	2496 cm <sup>3</sup> 2V	56 kW (76 PS) 20,6	90,54 mm	
92 189 6..., 93 118 6..								
[50]	∅ 9 mm							<b>MK-9H</b>
<b>141</b>		<b>93,7</b>						
<b>4GF</b>	06.1994 → 03.2000	D	(A)	4	2496 cm <sup>3</sup> 2V	63 kW (85 PS) 20,6	90,60 mm	
[50]	∅ 9 mm							<b>MK-9H</b>
IN [4]	9,05 x 5.01 x 41,5	B1						<b>81-11121</b>
IN [4]	9,15 x 5.01 x 41,5	B1						<b>81-11122</b> (1)
EX [4]	9,05 x 5.01 x 44,5	B1						<b>81-11123</b>
EX [4]	9,15 x 5.01 x 44,5	B1						<b>81-11124</b> (1)
(1)	1. oversize							

					Reference	Item No.	
<b>142</b>		<b>93,7</b>					
<b>4EB</b>	06.1994 → 12.2000	D (A)	4	2496 cm <sup>3</sup>	2V	74 kW (101 PS) 18,3	90,60 mm
<b>4EC</b>	06.1994 → 12.2000	D (A)	4	2496 cm <sup>3</sup>	2V	74 kW (101 PS) 18,3	90,60 mm
<b>4FB</b>	06.1994 → 12.2000	D (NA)	4	2496 cm <sup>3</sup>	2V	51 kW (70 PS) 20,5	90,60 mm
<b>4FC</b>	06.1994 → 12.2000	D (NA)	4	2496 cm <sup>3</sup>	2V	51 kW (70 PS) 20,5	90,60 mm
<b>4FD</b>	06.1994 → 12.2000	D (NA)	4	2496 cm <sup>3</sup>	2V	51 kW (69 PS) 20,6:1	90,60 mm
<b>4GE</b>	06.1994 → 03.2000	D (A)	4	2496 cm <sup>3</sup>	2V	63 kW (86 PS) 20,6:1	90,60 mm
<b>4HC</b>	06.1994 → 12.2000	D (NA)	4	2496 cm <sup>3</sup>	2V	56 kW (76 PS) 20,6	90,60 mm
	[50]	∅ 9 mm					<b>MK-9H</b>
<b>143</b>		<b>94</b>					
<b>LXD 2</b>	10.1982 → 12.1986	D	4	2304 cm <sup>3</sup>	2V	49 kW (67 PS) 23:1	83,00 mm
<b>YTR</b>	01.1987 → 02.1993	D (NA)	4	2304 cm <sup>3</sup>	2V	49 kW (67 PS) 22,2	83,00 mm
<b>YTT</b>	08.1982 → 09.1989	D (NA)	4	2304 cm <sup>3</sup>	2V	49 kW (67 PS) 22,2	83,00 mm
93 520 6..							
	IN [2]	40,4 x 8,5 x 116,2	S - -	- 30° - -	1 - III	83EM 6507 AA	<b>536766</b>
	[50]	∅ 8 mm					<b>KK-8H</b>
	IN/EX [4]	14,05 x 8,5 x 55,0	G1				<b>81-5303</b>
<b>144</b>		<b>94</b>					
<b>SFA</b>	06.1988 → 12.1994	D (A)	4	2498 cm <sup>3</sup>	2V	68 kW (92 PS) 21	90,00 mm
<b>SFB</b>	06.1988 → 12.1994	D (A)	4	2498 cm <sup>3</sup>	2V	68 kW (92 PS) 21	90,00 mm
<b>STP</b>	08.1982 → 08.1985	D (NA)	4	2499 cm <sup>3</sup>	2V	51 kW (69 PS) 23	90,00 mm
<b>STR</b>	12.1985 → 12.1994	D (NA)	4	2498 cm <sup>3</sup>	2V	51 kW (69 PS) 23	90,00 mm
93 625 6..							
	[50]	∅ 8 mm					<b>KK-8H</b>
	IN/EX [4]	14,05 x 8,5 x 55,0	G1				<b>81-5303</b>
<b>145</b>		<b>97</b>					
<b>OM 352.937</b>	12.1986 →	D (A)	6	5675 cm <sup>3</sup>	2V	110 kW (150 PS) 16:1	128,00 mm
90 276 7.., 92 581 6..							
	IN [2]	44,0 x 9 x 140,5	A/S - Cr -	- 45° - -	5 - III		<b>16136</b>
	EX [2]	36,0 x 10 x 140,5	A/S - Cr -	- 45° - -	5 - III		<b>16122</b>
	EX [2]	36,0 x 10 x 140,5	S - Cr -	- 45° - VS -	5 - III		<b>1604</b>
	EX [2]	36,0 x 10 x 140,6	A/S - Cr -	- 45° - -	5 - III		<b>16106</b>
	IN [6]	15,00 x 9 x 78,0	G1				<b>81-1609</b>
	IN [6]	15,03 x 9 x 72,0	G1				<b>81-1666</b>
	IN [6]	15,04 x 9 x 72,0	G1				<b>81-1674</b>
	EX [6]	15,00 x 10 x 73,0	G1				<b>81-1658</b>
	EX [6]	15,00 x 10 x 78,0	G1				<b>81-1631</b>
	EX [6]	15,03 x 10 x 67,0	G1				<b>81-1670</b>
	EX [6]	15,04 x 10 x 67,0	G1				<b>81-1676</b>
	EX [6]	15,10 x 10 x 78,0	G1				<b>81-1632</b>
	EX [6]	15,20 x 10 x 73,0	G1				<b>81-1659</b>
	IN [1]	45,08 x 37 x 8,3	G1 45°				<b>92-16112</b>
	IN [1]	45,87 x 37 x 8,2	G1 45°				<b>92-16114</b>
	EX [2]	38,07 x 30 x 8,5	G1 45°				<b>92-16109</b>
	EX [1]	38,38 x 30 x 8,5	G1 45°				<b>92-16131</b>
Fortsetzung nächste Seite / continued on next page / suite page suivante / continuación página próxima / Продолжение на следующей странице							

**F**

					Reference	Item No.	
[12]	M 28 x 60					<b>20 1003 35260</b>	
I [1]						<b>20 1003 36602 (1)</b>	
	(1) IN						
<b>146</b>		<b>100,775</b>					
<b>2708 E</b>	01.1965 → 1981	D	6	5494 cm <sup>3</sup>	2V	61 kW (83 PS) 16,5:1 114,80 mm	
<b>592 E</b>	01.1952 → 1965	D	4	3611 cm <sup>3</sup>	2V	51 kW (69 PS) 16:1 114,96 mm	
IN/EX [1]	15,90 x 9,5 x 76,2	G1				E1ADDN 6510A EIADDN 6510A <b>81-18103</b>	
<b>147</b>		<b>102</b>					
<b>6 BTAA Euro 2</b>	04.1992 →	D (LA)	6	5883 cm <sup>3</sup>	2V	94-173 kW (124-235 PS) 17-17,6 120,00 mm	
40 322 6.., 40 324 6.., 99 676 6..							
IN [2]	45,0 x 8 x 129,2	S - Cr -		- 30° -	-	18 - III	
EX [2]	42,0 x 8 x 129,0	A/S - Cr -		- 45° -	-	1 - III	
<b>148</b>		<b>102</b>					
<b>4 BTA 3.9 Euro 2</b>	04.2007 → 11.2012	D (LA)	4	3922 cm <sup>3</sup>	2V	57-97 kW (78-132 PS) 17,5:1 120,00 mm	
99 676 6..							
IN [2]	45,0 x 8 x 129,2	S - Cr -		- 30° -	-	18 - III	
EX [2]	42,0 x 8 x 129,0	A/S - Cr -		- 45° -	-	1 - III	
[1]	M 30 x 60 x 16					<b>20 1012 B6060</b>	
<b>149</b>		<b>104,775</b>					
<b>2700</b>	01.1965 → 1969	D	4	3966 cm <sup>3</sup>	2V	61 kW (83 PS) 16,5:1 114,90 mm	
<b>2701 E</b>	01.1965 → 1969	D	4	3966 cm <sup>3</sup>	2V	61 kW (83 PS) 16,5:1 114,90 mm	
<b>2703 E</b>	01.1965 → 1981	D	6	5939 cm <sup>3</sup>	2V	61 kW (83 PS) 16,5:1 114,808 mm	
<b>2704 E</b>	01.1965 → 1969	D	6	5944 cm <sup>3</sup>	2V	97 kW (130 PS) 16,5:1 114,90 mm	
<b>2706 E</b>	01.1965 → 1981	D	4	3966 cm <sup>3</sup>	2V	61 kW (83 PS) 16,5:1 114,90 mm	
<b>2709 E</b>	01.1965 → 1981	D	6	5944 cm <sup>3</sup>	2V	97 kW (130 PS) 16,5:1 114,90 mm	
<b>360 DT</b>	01.1968 → 1981	D (A)	6	5944 cm <sup>3</sup>	2V	106 kW (144 PS) 15,7:1 114,90 mm	
IN/EX [1]	15,90 x 9,5 x 76,2	G1				E1ADDN 6510A EIADDN 6510A <b>81-18103</b>	
<b>150</b>		<b>106,68</b>					
<b>2502 E</b>	01.1965 →	D	3	2589 cm <sup>3</sup>	2V	25-30 kW (34-41 PS) 17,3:1 96,52 mm	
IN [2]	45,8 x 9,4 x 145,9	S - -		- 45° -	-	6 - III C5NE 6507 A D3NN6507A	
EX [2]	38,4 x 9,4 x 145,9	A/S - -		- 45° -	-	20 - III C5NE 6505 A	
<b>151</b>		<b>106,698</b>					
<b>2504 E</b>	01.1965 →	D	3	2870 cm <sup>3</sup>	2V	35 kW (47 PS) 16,5:1 106,68 mm	
<b>ND</b>	01.1965 →	D	3	2870 cm <sup>3</sup>	2V	32-35 kW (44-47 PS) 16,5:1 106,68 mm	
<b>RD</b>	1965 →	D	4	3815 cm <sup>3</sup>	2V	46-50 kW (62-68 PS) 16,5:1 106,68 mm	
IN [2]	45,8 x 9,4 x 145,9	S - -		- 45° -	-	6 - III C5NE 6507 A D3NN6507A	
EX [2]	38,4 x 9,4 x 145,9	A/S - -		- 45° -	-	20 - III C5NE 6505 A	
<b>152</b>		<b>107</b>					
<b>ISB 4.5L Euro 6</b>	01.2012 →	D (LA)	4	4500 cm <sup>3</sup>	4V	99-154 kW (133-207 PS) 17,3:1 124,00 mm	
41 541 6..							

Fortsetzung nächste Seite / continued on next page / suite page suivante / continuación página próxima / Продолжение на следующей странице

					Reference	Item No.
IN [2] EX [2]	33,0 x 7 x 124,7 33,0 x 7 x 124,3	S - Cr - A/S - Cr -	- 30° - - - 45° - -	9 - III 9 - III		<b>105-35632</b> <b>105-35633</b>
[50]	Ø 7 mm					<b>RK-7H</b>
IN [2] EX [2]	34,91 x 29.6 x 5,8 34,91 x 29.5 x 5,8	G1 20° G1 20°				<b>92-17000</b> <b>92-17001</b>

## 153 107

**ISB 6.7L Euro 6** 01.2012 → D (A) 6 6700 cm<sup>3</sup> 4V 150-242 kW (200-325 PS) 17,3:1 124,00 mm  
41 541 6..

IN [2] EX [2]	33,0 x 7 x 124,7 33,0 x 7 x 124,3	S - Cr - A/S - Cr -	- 30° - - - 45° - -	9 - III 9 - III		<b>105-35632</b> <b>105-35633</b>
[50]	Ø 7 mm					<b>RK-7H</b>
IN [2] EX [2]	34,91 x 29.6 x 5,8 34,91 x 29.5 x 5,8	G1 20° G1 20°				<b>92-17000</b> <b>92-17001</b>
[1]	M 30 x 60 x 16					<b>20 1012 B6060</b>

## 154 107,21

**2711 E** 01.1969 → 1981 D 4 4161 cm<sup>3</sup> 2V 55 kW (75 PS) 16,5:1 114,96 mm  
**2712 E** D 4 4161 cm<sup>3</sup> 2V 50-59 kW (68-80 PS) 16,5:1 114,96 mm  
**2714 E** 01.1969 → 1981 D 6 6227 cm<sup>3</sup> 2V 77 kW (105 PS) 16,5:1 114,80 mm  
**2715 C** D 6 6227 cm<sup>3</sup> 2V 82 kW (112 PS) 16:1 114,80 mm  
**2715 E** D 6 6227 cm<sup>3</sup> 2V 77-86 kW (105-117 PS) 16,5:1 114,80 mm

IN/EX [1]	15,90 x 9,5 x 76,2	G1			E1ADDN 6510A EIADDN 6510A	<b>81-18103</b>
-----------	--------------------	----	--	--	------------------------------	-----------------

## 155 111,778

**2512 E** 1968 → D 3 3294 cm<sup>3</sup> 2V 44 kW (60 PS) 16,5:1 111,76 mm  
**6Y 4.2** 01.1971 → D (A) 4 4195 cm<sup>3</sup> 2V 69 kW (94 PS) 15,6:1 106,70 mm  
**6Y 6.6** 1972 → D 6 6588 cm<sup>3</sup> 2V 76 kW (104 PS) 16,3:1 111,76 mm  
**7A 4.2** 01.1971 → D (A) 4 4195 cm<sup>3</sup> 2V 69 kW (94 PS) 16,5:1 106,68 mm  
**7A 6.6 102 kW** 01.1969 → D (A) 6 6588 cm<sup>3</sup> 2V 102-137 kW (138-186 PS) 16:1 111,75 mm  
**7A 6.6 81 kW** 1972 → D 6 6588 cm<sup>3</sup> 2V 81 kW (110 PS) 16,3:1 111,76 mm  
**BSD 444** 09.1981 → 12.1985 D 4 4392 cm<sup>3</sup> 2V 60 kW (82 PS) 16,3:1 111,89 mm  
**BSD 444 T** 09.1981 → 12.1988 D (A) 4 4392 cm<sup>3</sup> 2V 68 kW (92 PS) 15,6:1 111,89 mm  
 93 858 6..

IN [2]	45,8 x 9,4 x 145,9	S - -	- 45° - -	6 - III	C5NE 6507 A D3NN6507A	<b>105-34048</b>
EX [2]	38,4 x 9,4 x 145,9	A/S - -	- 45° - -	20 - III	C5NE 6505 A	<b>105-34049</b>
EX [2]	38,5 x 9,4 x 146,0	A/S - -	- 45° - -	20 - III	839 12598	<b>181101</b>

## 156 111,8

**675 TA/HD** D (LA) 6 7480 cm<sup>3</sup> 4V 106 kW (144 PS) 127,00 mm  
41 500 6..

IN [2]	47,5 x 9,5 x 147,0	S - Cr -	- 30° - -	23 - III	87802256	<b>105-35646</b>
EX [2]	43,0 x 9,5 x 146,6	A/S - Cr -	- 45° - VS -	23 - III	87802258	<b>105-35647</b>

## 157 114

**6 CTAA 8.3** 11.1991 → D (LA) 6 8268 cm<sup>3</sup> 2V 213-235 kW (290-320 PS) 17,5:1 135,00 mm  
**ISL e Euro 4/5** 09.2012 → D (LA) 6 8900 cm<sup>3</sup> 4V 205-279 kW (330-449 PS) 16,9:1 145,00 mm

[1]	M					<b>20 1012 20000</b>
-----	---	--	--	--	--	----------------------



					Reference	Item No.
<b>158</b>		<b>114</b>				
<b>ISC 8.3L Euro 3</b> 06.2007 → D (A) 6 8270 cm <sup>3</sup> 2V 238 kW (319 PS) 17,5:1 135,00 mm 40 437 6..						
	IN [2] EX [2]	38,0 x 8 x 137,8 38,0 x 8 x 137,8	S - Cr - A/S - Cr -	- 30° - - - 45° - -	9 - III 9 - III	<b>105-35644</b> <b>105-35645</b>
	[1]	M				<b>20 1012 20000</b>
<b>159</b>		<b>125</b>				
<b>F 6 L 413 FZ</b> 04.1982 → 12.1999 D 6 9572 cm <sup>3</sup> 2V 150 kW (204 PS) 130,00 mm						
	IN [2] IN [2] EX [2] EX [2]	53,6 x 10 x 165,0 53,6 x 10 x 165,0 46,5 x 10 x 165,3 46,5 x 9,9 x 165,3	S - - S - Cr - A/S - Cr - RA/S- Cr -	- 45° - - - 45° - - - 45° - - - 45° - -	1 - III 23 - III 1 - III 23 - III	<b>2254</b> <b>22202</b> <b>2294</b> <b>22155</b>
	[50] [50]	∅ 10 mm ∅ 10 mm				<b>KK-10H</b> <b>MK-10H</b>
	IN [4] EX [4] EX [4]	16,04/19 x 10 x 95,0 16,04/19 x 10 x 78,0 16,54/19 x 10 x 78,0	G2 G2 G2			<b>81-2255</b> <b>81-2258</b> <b>81-2260</b>
	IN [2] EX [2]	56,17 x 47.06 x 11,5 49,18 x 41.98 x 11,5	G1 45° G1 45°			<b>92-22017</b> <small>NEW</small> <b>92-22018</b> <small>NEW</small>
	[12]	M 34 x 60 x 18				<b>20 1005 41360</b>
<b>160</b>		<b>125</b>				
<b>F 6 L 413 F</b> 04.1982 → D (NA) 6 9572 cm <sup>3</sup> 2V 104-188 kW (141-256 PS) 18:1 130,00 mm 93 224 6..						
	IN [2] IN [2] EX [2] EX [2]	53,6 x 10 x 165,0 53,6 x 10 x 165,0 46,5 x 10 x 165,3 46,5 x 9,9 x 165,3	S - - S - Cr - A/S - Cr - RA/S- Cr -	- 45° - - - 45° - - - 45° - - - 45° - -	1 - III 23 - III 1 - III 23 - III	<b>2254</b> <b>22202</b> <b>2294</b> <b>22155</b>
	[50] [50]	∅ 10 mm ∅ 10 mm				<b>KK-10H</b> <b>MK-10H</b>
	IN [2] EX [2]	56,17 x 47.06 x 11,5 49,18 x 41.98 x 11,5	G1 45° G1 45°			<b>92-22017</b> <small>NEW</small> <b>92-22018</b> <small>NEW</small>
	[12]	M 34 x 60 x 18				<b>20 1005 41360</b>
<b>161</b>		<b>125</b>				
<b>F3AE3681D Euro 4/5</b> 09.2012 → D (LA) 6 10308 cm <sup>3</sup> 4V 310 kW (422 PS) 140,00 mm 41 478 6..						
	IN [2] EX [2]	43,0 x 9 x 202,9 42,0 x 9 x 201,6	S - Cr - RA/S- Cr -	- 30° - - - 45° - -	1 - III 1 - III	<b>171072</b> <b>171109</b>
	[50]	∅ 9 mm				<b>KK-9H</b>
	IN [1] EX [1]	15,02/13 x 9.02 x 97,0 G2 15,02/13 x 9.02 x 97,0 G2				<b>81-17134</b> <small>NEW</small> <b>81-17135</b> <small>NEW</small>
						<b>20 1014 19000</b> <small>NEW</small>

		Cyl.		mm	cm <sup>3</sup>		Comp. Ratio $\epsilon$	kW	PS	Pos
138 C2.048	B (NA)	4		86,4 x 63,9	1498	2	9-9,2	55	75	44
156 A.000	B (NA)	4		76,1 x 57,8	1049	2	9,5	40-41	54-56	13
156 A2.000	B (NA)	4		70 x 64,9	999	2	9,5-9,8	33-37	45-50	6
156 A2.100	B (NA)	4		70 x 64,9	999	2	9	32	44	7
156 A2.246	B (NA)	4		70 x 64,9	999	2	9,5	33	45	6
156 C.000	B (NA)	4		70 x 72	1108	2	9-9,6	42	57	6
156 C.046	B (NA)	4		70 x 72	1108	2	9	37-40	50-54	6
175 A3.000	B (A)	5		82 x 75,65	1998	4	8,5	162	220	20
175 A4.000	B (A)	4		84 x 90	1995	4	8	142	193	34
176 B2.000	B (NA)	4		70 x 72	1108	2	9,6	40	54	6
176 B9.000	B (NA)	4		70,8 x 78,9	1242	4	10,2	63	86	9
182 A2.000	B (NA)	4		82 x 82,7	1747	4	10	66-83	90-113	19
182 A4.000	B (NA)	4		86,4 x 67,4	1581	4	10,2	76	103	46
182 A6.000	B (NA)	4		86,4 x 67,4	1581	4	10,1	66	90	47
182 B6.000	B (NA)	4		80,5 x 78,4	1596	4	10,1	76	103	16
182 B7.000	B (NA)	5		82 x 75,65	1998	4	10,7	113	154	19
183 A1.000	B (NA)	4		82 x 82,7	1747	4	10,3	96	131	19
185 A8.000 Euro 3	B (NA)	5		82 x 75,7	1998	4	10,5	110	150	21
188 A4.000	B (NA)	4		70,8 x 78,9	1242	2	10,6	44	60	8
188 A5.000 Euro 3	B (NA)	4		70,8 x 78,9	1242	4	10,6	59	80	9
188 A9.000	D (NA)	4		69,6 x 82	1248	4	18	51	70	3
188 B2.000	D (LA)	4		82 x 90,4	1910	2	18	74	101	25
192 B2.000	B (NA)	4		72 x 84	1368	4	11	66	90	11
198 A1.000	B (A)	4		72 x 84	1368	4	9,6-10	110	150	12
198 A2.000	D (LA)	4		79,5 x 80,5	1598	4	16,1-16,9	88	120	14
198 A4.000	B (A)	4		72 x 84	1368	4	9,6-10	88	120	12
198 A5.000	D (LA)	4		83 x 90,4	1956	4	16,1-16,9	121	165	30
199 A2.000	D (LA)	4		69,6 x 82	1248	4	18	55	75	3
199 A3.000	D (LA)	4		69,6 x 82	1248	4	18	66-77	90-105	4
199 B1.000 Euro 5	D (LA)	4		69,6 x 82	1248	4	16,8	57-70	77-95	5
350 A1.000	B (NA)	4		72 x 84	1368	2	11	55-57	75-78	10
350 A2.000 Euro 5	D (LA)	4		79,5 x 80,5	1598	4	16,5	85-88	116-120	14
4HP	D (LA)	4		85 x 96	2179	4		120	163	41
4HR	D (LA)	4		85 x 96	2179	4	17,6:1	120	163	41
4HT Euro 4	D (LA)	4		85 x 96	2179	4	17,5	125	170	43
4HW (DW12ATED4)	D (LA)	4		85 x 96	2179	4	18	94	128	39
8144. 97S	D (A)	4		93 x 92	2500	2	21	77	105	52
8144.91	D (A)	4		93 x 90	2445	2	22	74	101	52
8144.97	D (A)	4		93 x 92	2499	2	22	85	115	53
8144.97 Y	D (A)	4		93 x 92	2500	2	22,5	85	115	53
828 B.000	B (NA)	4		84 x 71,5	1585	2	9,3	74	100	31
828 B1.000	B (NA)	4		84 x 90	1995	2	8,9	85-90	116-122	31
828 B4.000	B (NA)	4		84 x 90	1995	2	8,9	90	122	31
831 A1.000	B (NA)	4		86,4 x 63,9	1498	2	9,2	63	86	44
831 A2.000	B (NA)	4		86,4 x 55,5	1301	2	9,5	55-58	75-79	44
831 A4.000	B (NA)	4		84 x 71,5	1585	2	9,5	77	105	31
831 B.000	B (NA)	4		86,4 x 55,5	1301	2	9,5	55	75	44
831 B3.000	B (LA)	4		84 x 71,5	1585	2	8	103	140	32
831 D1.000	D (LA)	4		82,6 x 90	1929	2	20	48-59	55-80	27
834 B.000	B (NA)	4		84 x 90	1995	2	9,8	88	120	31
834 B2.000	B (NA)	4		84 x 90	1995	4	8:1	108	147	33
834 E.146	B (NA)	6		91 x 73	2849	2	9,5:1	108-110	147-150	49
834 F.000	B (NA)	6		93 x 72,6	2959	2	9,5:1	126	171	50
834 F1.000	B (NA)	4		84 x 90	1995	4	10,35:1	110-112	150-152	33
834 F2.000	B (LA)	4		84 x 90	1995	4	8:1	148	202	33
835 A1.000	B (NA)	4		86,4 x 67,4	1581	2	9,2	65-66	88-90	45
835 A4.000	D (A)	4		82,6 x 90	1929	2	19,9	66	90	28
836 A2.000	B (LA)	4		84 x 90	1995	4	10	137	186	33
836 A3.000	B (NA)	4		84 x 90	1995	4	10	102-108	139-147	33
838 A1.000	B (NA)	5		82 x 75,65	1998	4	10	107	146	17
838 A2.000	B (NA)	5		83 x 90,4	2446	4	10	129	175	29
838 A2.027	B (NA)	5		83 x 90,4	2446	4	10	129	175	29
838 A3.000	D (LA)	5		82 x 90,4	2387	2	21	91	124	22
838 A4.000	B (A)	4		84 x 90	1995	4	8	151	205	33
838 A6.000	B (NA)	5		82 x 75,65	1998	4	10,4	114	155	19
838 A7.000	D (LA)	5		82 x 90,4	2387	2	21	91	124	22
838 A8.000	D (A)	5		82 x 90,4	2387	2	18,45	100	136	23

		Cyl.		mm	cm <sup>3</sup>		Comp. Ratio ε	kW	PS	Pos
838 B.000	B (NA)	6	93 x 72,6	2959	4	10	150	204	51	
839 A4.000	B (NA)	4	82 x 82,7	1747	4	10,3:1	96	131	19	
839 A5.000	D (LA)	5	82 x 90,4	2387	2	18,5	96-99	131-135	23	
839 A6.000 Euro 3	D (LA)	5	82 x 90,4	2387	2	18,45	103	140	23	
839 A7.000	B (NA)	4	82 x 82,7	1747	4	10,3	96	131	19	
840 A2.000	B (NA)	4	82 x 64,9	1370	3	9,85	55-59	75-80	18	
840 A3.000	B (NA)	4	70,8 x 78,9	1242	2	9,8	44	60	8	
840 A4.000	B (NA)	4	82 x 64,9	1370	3	9,85	55	75	18	
841 A.000	B (NA)	6	93 x 72,6	2959	4	10	158	215	51	
841 C.000	D (LA)	5	82 x 90,4	2387	2	18,5	110	150	23	
841 D.000	B (NA)	5	83 x 90,4	2446	4	10,3	125	170	29	
841 E.000	B (LA)	5	82 x 75,65	1998	4	8,5	136	185	19	
841 G.000	D (LA)	5	82 x 90,4	2387	4	18,45:1	129	175	24	
841 N.000	D (LA)	5	82 x 90,4	2387	4	18,45:1	120	163	24	
844 A1.000	D (LA)	4	82 x 90,4	1910	4	16,1-16,9	140	190	26	
844 A2.000	D (A)	4	83 x 90,4	1956	4	16,5	120	163	30	
937 A2.000	D (LA)	4	82 x 90,4	1910	2	18,45:1	85	116	23	
944 A 3.000	D (LA)	4	79,5 x 80,5	1598	4	16,5	77	105	15	
955 A4.000	D (LA)	4	79,5 x 80,5	1598	4	16,5	85	116	14	
A112 A.000	B (NA)	4	65 x 68	903	2	9	21-32	29-44	1	
A112 A5.000	B (NA)	4	65 x 68	903	2	9	29-31	40-42	1	
A112 B1.000	B (NA)	4	67,2 x 68	965	2	9,2	35	48	2	
A112 B2.000	B (NA)	4	65 x 68	903	2	9	29-32	40-44	1	
AR 32302	D (A)	4	82 x 90,4	1910	2	18,5	77	105	23	
AR 32501	D (LA)	5	82 x 90,4	2387	2	18,5	99-100	135-136	23	
AR 37101	D (LA)	4	82 x 90,4	1910	2	18,5	80-85	109-116	23	
ES9 J4S	B (NA)	6	87 x 82,6	2946	4	10,9	150	204	48	
P 8 C	D (A)	4	85 x 92	2088	3	21,5	80	109	36	
RFN	B (NA)	4	85 x 88	1997	4	10,8	100	136	35	
RFN (EW10J4)	B (NA)	4	85 x 88	1997	4	10,8	100	136	35	
RHK (DW10UTED4) Euro 4	D (LA)	4	85 x 88	1997	4	17,5	79-88	107-120	42	
RHM (DW10ATED4)	D (LA)	4	85 x 88	1997	4	17,6	79	107	40	
RHR (DW10BTED4) Euro 4	D (LA)	4	85 x 88	1997	4	18	100	136	42	
RHW (DW10ATED4)	D (LA)	4	85 x 88	1997	4	17,1	80-81	109-110	38	
RHZ (DW10ATED)	D (LA)	4	85 x 88	1997	2	18	80	109	37	

						Pos							Pos									
					1.6 D Multijet (844.AXF11, 844.AXF1A)					08.2008 → 08.2014	955 A4.000	D	14									
<b>A 112</b>					1.6 D Multijet (844.AXP1A)					04.2011 → 08.2014	944 A 3.000	D	15									
0.9 Junior (A112B/2)					03.1981 → 06.1986	A112 A.000	B	1	1.9 D Multijet (844.AXE1A)					01.2009 → 08.2014	844 A1.000	D	26					
0.9 Junior (A112B/2)					03.1981 → 06.1986	A112 A5.000	B	1	2.0 D Multijet (844.AXD1A, 844.AXM1A)					09.2008 → 08.2014	198 A5.000	D	30					
0.9 Junior (A112B/2)					03.1981 → 06.1986	A112 B2.000	B	1	2.0 D Multijet (844.AXG1A, 844.AXN1A)					09.2008 → 08.2014	844 A2.000	D	30					
1.0 LX (A112)					03.1984 → 12.1986	A112 B1.000	B	2	<b>BETA H.P.E. (828 )</b>													
<b>BETA H.P.E. (828 )</b>					1600 (828BF0)					08.1980 → 09.1984	828 B.000	B	31	<b>KAPPA (838 )</b>								
2000 (828.BF)					05.1976 → 05.1978	828 B1.000	B	31	2.0 16V Turbo (838AB1AA)					02.1995 → 10.2001	838 A4.000	B	33					
2000 (828.BF)					04.1979 → 09.1984	828 B1.000	B	31	2.0 20V (838AA1AA)					10.1994 → 10.2001	838 A1.000	B	17					
2000 i.e. (828BF)					05.1981 → 09.1984	828 B4.000	B	31	2.0 20V (838AG1AA, 838AG11A)					07.1996 → 10.2001	838 A6.000	B	19					
<b>BETA (828 )</b>					1600 (828CB0, 828AB0)					08.1973 → 07.1982	828 B.000	B	31	2.0 20V Turbo (838AM1AA)					06.1998 → 10.2001	175 A3.000	B	20
1600 (828CB1)					07.1978 → 07.1982	828 B1.000	B	31	2.4 20V (838AC1AA, 838AC11A)					08.1994 → 10.2001	838 A2.000	B	29					
<b>BETA Coupe (828 )</b>					1600 (828BC0)					04.1976 → 12.1984	828 B.000	B	31	2.4 20V (838AC1AA, 838AC11A)					08.1994 → 10.2001	838 A2.027	B	29
2000 (828.BC)					04.1976 → 12.1984	828 B1.000	B	31	2.4 JTD (838AL1AA)					06.1998 → 10.2001	838 A8.000	D	23					
2000 (828BC )					01.1981 → 12.1984	828 B1.000	B	31	2.4 T.DS (838AE1AA, 838AH1AA)					08.1994 → 10.2001	838 A3.000	D	22					
2000 i.e. (828.BC)					12.1981 → 12.1984	828 B4.000	B	31	2.4 T.DS (838AE1AA, 838AH1AA)					08.1994 → 10.2001	838 A7.000	D	22					
<b>BETA Saloon (828 )</b>					1600 (828DB1)					03.1976 → 10.1986	828 B.000	B	31	3.0 24V (838AD1AA, 838AD11A, 838XD1AA, 838ZD1AA)					10.1994 → 10.2001	838 B.000	B	51
1600 (828DB1)					03.1976 → 10.1986	828 B.000	B	31	<b>KAPPA Coupe (838 )</b>													
2000 (828CB1)					04.1976 → 07.1978	828 B1.000	B	31	2.0 16V Turbo (838CB)					11.1996 → 03.2001	838 A4.000	B	33					
<b>BETA Spider (828 )</b>					1600 (828BS0)					05.1976 → 10.1986	828 B.000	B	31	2.0 20V Turbo (838CM)					06.1998 → 03.2001	175 A3.000	B	20
1600 (828BS0)					05.1976 → 10.1986	828 B.000	B	31	2.4 20V (838CC)					11.1996 → 03.2001	838 A2.000	B	29					
2000 (828BS1)					05.1976 → 11.1979	828 B1.000	B	31	3.0 24V (838CD, 838CD11A)					09.1996 → 03.2001	838 B.000	B	51					
2000 (828BS1)					04.1979 → 10.1986	828 B1.000	B	31	<b>KAPPA SW (838 )</b>													
<b>DEDRA (835 )</b>					1.6 16V (835EI)					01.1996 → 07.1999	182 A4.000	B	46	2.0 16V Turbo (838BG1AA)					07.1996 → 10.2001	838 A4.000	B	33
1.6 i.e. (835AA)					08.1989 → 06.1994	835 A1.000	B	45	2.0 20V (838BH1AA)					07.1996 → 10.2001	838 A6.000	B	19					
1.8 16V LE (835FG)					03.1996 → 07.1999	182 A2.000	B	19	2.0 20V Turbo (838BC1AA, 838BC11A)					07.1996 → 10.2001	838 A2.000	B	29					
1.8 GT 16V (835EH)					03.1996 → 07.1999	183 A1.000	B	19	2.4 JTD (838BL1AA)					06.1998 → 10.2001	838 A8.000	D	23					
1.9 TDS (835EE, 835EF)					04.1989 → 07.1999	835 A4.000	D	28	2.4 T.DS (838BH1AA)					07.1996 → 10.2001	838 A3.000	D	22					
2.0 16V (835ED)					07.1994 → 07.1999	836 A3.000	B	33	2.4 T.DS (838BH1AA)					07.1996 → 10.2001	838 A7.000	D	22					
<b>DEDRA SW (835 )</b>					1.6 16V (835EI)					01.1996 → 07.1999	182 A4.000	B	46	3.0 24V (838BD11A)					07.1996 → 10.2001	838 B.000	B	51
1.6 16V (835EI)					01.1996 → 07.1999	182 A4.000	B	46	<b>KAPPA SW (838 )</b>													
1.8 16V LE (835FG)					03.1996 → 07.1999	182 A2.000	B	19	2.0 16V Turbo (838BB1AA)					07.1996 → 10.2001	838 A4.000	B	33					
1.8 GT 16V (835EH)					03.1996 → 07.1999	183 A1.000	B	19	2.0 20V (838BG1AA)					07.1996 → 10.2001	838 A6.000	B	19					
1.9 TDS (835EE, 835EF)					07.1994 → 07.1999	835 A4.000	D	28	2.0 20V Turbo (838BM1AA)					06.1998 → 10.2001	175 A3.000	B	20					
2.0 16V (835ED)					07.1994 → 07.1999	836 A3.000	B	33	2.4 20V (838BC1AA, 838BC11A)					07.1996 → 10.2001	838 A2.000	B	29					
2.0 Integrale (835ED)					07.1994 → 07.1999	836 A3.000	B	33	2.4 JTD (838BL1AA)					06.1998 → 10.2001	838 A8.000	D	23					
<b>DELTA I (831 )</b>					1.3 (831.AB)					09.1983 → 08.1992	831 A2.000	B	44	2.4 T.DS (838BH1AA)					07.1996 → 10.2001	838 A3.000	D	22
1.3 (831.AB.011)					09.1979 → 08.1992	831 A2.000	B	44	2.4 T.DS (838BH1AA)					07.1996 → 10.2001	838 A7.000	D	22					
1.3 (831.AB.011)					09.1979 → 08.1992	831 B.000	B	44	3.0 24V (838BD11A)					07.1996 → 10.2001	838 B.000	B	51					
1.5 (831.AB.025)					09.1979 → 04.1986	831 A1.000	B	44	<b>LYBRA (839 )</b>													
1.5i					12.1985 → 10.1987	138 C2.048	B	44	1.6					10.2000 → 10.2005	182 B6.000	B	16					
1.6 GT (831.AB.06)					11.1982 → 04.1986	831 A4.000	B	31	1.6 16V (839AXA1A)					07.1999 → 10.2005	182 A4.000	B	46					
1.6 HF Turbo (831.AB.020)					08.1986 → 08.1988	831 B3.000	B	32	1.8 16V (839AXB1A, 839AXG1A)					07.1999 → 10.2005	839 A4.000	B	19					
1.9 Turbo DS (831.AB.021)					10.1986 → 12.1989	831 D1.000	D	27	1.8 16V (839AXB1A, 839AXG1A)					09.2000 → 10.2005	839 A7.000	B	19					
<b>DELTA II (836 )</b>					1.6 i.e. (836AP)					03.1996 → 08.1999	182 A6.000	B	47	1.9 JTD (839.AX11A, 839.AXN1A, 839.CXL1A)					05.2001 → 10.2005	937 A2.000	D	23
1.6 i.e. 16V (836AO)					01.1996 → 08.1999	182 A4.000	B	46	1.9 JTD (839AXD1A)					07.1999 → 09.2000	AR 32302	D	23					
1.8 i.e. 16V (836AQ)					03.1996 → 08.1999	182 A2.000	B	19	1.9 JTD (839AXI1A)					09.2000 → 05.2001	AR 37101	D	23					
1.8 i.e. 16V GT (836AR)					03.1996 → 08.1999	183 A1.000	B	19	2.0 20V (839AXC11, 839AXC1A)					07.1999 → 09.2000	182 B7.000	B	19					
1.9 TD (836AM, 836AN)					10.1994 → 08.1999	835 A4.000	D	28	2.0 20V (839AXH1A)					09.2000 → 10.2005	185 A8.000	B	21					
2.0 16V (836AA, 836CA)					06.1993 → 08.1999	836 A3.000	B	33	2.4 JTD (839.AXE1A)					05.2002 → 10.2005	841 C.000	D	23					
2.0 16V Turbo (836AB)					06.1993 → 08.1999	836 A2.000	B	33	2.4 JTD (839AXE1A)					07.1999 → 02.2001	839 A5.000	D	23					
2.0 16V Turbo (836AS)					07.1996 → 08.1999	175 A4.000	B	34	2.4 JTD (839AXE1A)					07.1999 → 02.2001	AR 32501	D	23					
<b>DELTA III (844 )</b>					1.4 (844.AXA1A)					09.2008 → 08.2014	198 A4.000	B	12	2.4 JTD (839AXL1A)					09.2000 → 05.2002	839 A6.000	D	23
1.4 (844.AXB1A)					09.2008 → 08.2014	198 A1.000	B	12	<b>LYBRA SW (839 )</b>													
1.4 Bifuel (844.AXA1A)					07.2011 → 08.2014	198 A4.000	B	12	1.6 D Multijet (844.AXC11, 844.AXC1A)					09.2008 → 08.2014	198 A2.000	D	14					

				Pos					Pos
1.6 (839.BXF1A)	10.2000 → 10.2005	182 B6.000	B	16	1.9 Turbo Diesel	05.1985 → 12.1989	831 D1.000	D	27
1.6 16V (839BXA1A)	07.1999 → 10.2005	182 A4.000	B	46	(831AB)				
1.8 16V (839BXB1A, 839BXG1A)	07.1999 → 10.2005	839 A4.000	B	19	<b>SCORPION (137_)</b>				
1.8 16V (839BXB1A, 839BXG1A)	09.2000 → 10.2005	839 A7.000	B	19	2.0 (137AS)	06.1981 → 10.1983	828 B1.000	B	31
1.9 JTD (839.BXI1A, 839.BXN1A, 839.CXL1A)	05.2001 → 10.2005	937 A2.000	D	23	<b>THEMA (834_)</b>				
1.9 JTD (839BXD1A)	07.1999 → 09.2001	AR 32302	D	23	2000 16V (834FA)	08.1992 → 12.1993	834 F1.000	B	33
1.9 JTD (839BXI1A)	09.2000 → 05.2001	AR 37101	D	23	2000 16V Turbo (834GC, 834FC)	10.1992 → 07.1994	834 F2.000	B	33
2.0 20V (839BXC11, 839BXC1A)	07.1999 → 09.2000	182 B7.000	B	19	2000 i.e. (834B)	11.1984 → 09.1988	834 B.000	B	31
2.0 20V (839BXH1A)	09.2000 → 10.2005	185 A8.000	B	21	2000 i.e. 16V (834AA)	05.1988 → 08.1992	834 B2.000	B	33
2.4 JTD (839.BXE1A)	05.2002 → 10.2005	841 C.000	D	23	2500 Turbo D (834D)	11.1984 → 09.1988	8144.91	D	52
2.4 JTD (839BXE1A)	10.1999 → 09.2000	839 A5.000	D	23	2500 Turbo DS (834AE)	06.1988 → 05.1992	8144.97	D	53
2.4 JTD (839BXE1A)	10.1999 → 09.2000	AR 32501	D	23	2500 Turbo DS (834AM)	05.1988 → 07.1992	8144.97S	D	52
2.4 JTD (839BXL1A)	09.2000 → 10.2005	839 A6.000	D	23	2500 Turbo DS (834FE, 834LE)	05.1992 → 07.1994	8144.97 Y	D	53
<b>MUSA (350_)</b>					2850 V6 i.e. (834AD, 834CD, 834BD)	06.1988 → 05.1992	834 E.146	B	49
1.3 D Multijet (350.AXB11, 350.AXB1A)	10.2004 → 09.2012	188 A9.000	D	3	2850 V6 i.e. (834F)	11.1984 → 09.1988	834 E.146	B	49
1.3 D Multijet (350.AXG11, 350.AXG1A)	09.2006 → 09.2012	199 A3.000	D	4	3000 V6 (834GD, 834FD)	08.1992 → 07.1994	834 F.000	B	50
1.3 D Multijet (350.AXM11, 350.AXM1A, 350.AXI1A)	03.2009 → 09.2012	199 B1.000	D	5	<b>THEMA SW (834_)</b>				
1.4 (350.AXE1A)	10.2007 → 09.2012	192 B2.000	B	11	2000 16V (834FA)	05.1992 → 07.1994	834 F1.000	B	33
1.4 (350.AXF1A)	09.2005 → 09.2012	350 A1.000	B	10	2000 Turbo 16V (834GC, 834FC)	11.1992 → 07.1994	834 F2.000	B	33
1.4 LPG (350.AXF1A)	11.2010 → 09.2012	350 A1.000	B	10	2000 i.e. 16V (834AA)	05.1989 → 08.1992	834 B2.000	B	33
1.6 D Multijet (350.AXH1A)	07.2008 → 09.2012	350 A2.000	D	14	2500 Turbo DS (834AE)	06.1988 → 05.1992	8144.97	D	53
1.6 D Multijet (350.AXL1A, 350.AXH1A)	07.2008 → 09.2012	350 A2.000	D	14	2500 Turbo DS (834AM)	05.1988 → 07.1992	8144.97S	D	52
1.9 D Multijet (350.AXC1A)	10.2004 → 09.2012	188 B2.000	D	25	2500 Turbo DS (834D)	03.1987 → 09.1990	8144.91	D	52
<b>PHEDRA (179_)</b>					2500 Turbo DS (834FE, 834LE)	09.1992 → 07.1994	8144.97 Y	D	53
2.0 (179AXA11, 179AXA1A)	09.2002 → 11.2010	RFN (EW10J4)	B	35	3000 V6 (834GD, 834FD)	09.1992 → 07.1994	834 F.000	B	50
2.0 D Multijet (179.AXL1B, 179.BXL1B)	07.2006 → 11.2010	RHR (DW10BTED4)	D	42	<b>THESIS (841_)</b>				
2.0 JTD (179.AXE1A)	07.2003 → 11.2010	RHM (DW10ATED4)	D	40	2.0 Turbo (841AXA1B03)	07.2002 → 07.2009	841 E.000	B	19
2.0 JTD (179.AXH1B, 179.BXH1B)	06.2006 → 11.2010	RHK (DW10UTED4)	D	42	2.4 (841AXB1B00)	07.2002 → 07.2009	841 D.000	B	29
2.0 JTD (179AXB1A)	09.2002 → 11.2010	RHW (DW10ATED4)	D	38	2.4 JTD (841.AXE1B0, 841.AXH110)	05.2003 → 07.2009	841 G.000	D	24
2.2 D Multijet (179.AXM1B, 179.AXP11, 179.BXM1B,....)	03.2008 → 11.2010	4HT	D	43	2.4 JTD (841.AXE1B0, 841.AXH110)	09.2003 → 07.2009	841 N.000	D	24
2.2 JTD (179.AXN1B, 179.AXQ11, 179.BXN1B, 179.BXQ11)	04.2006 → 11.2010	4HP	D	41	2.4 JTD (841AXD1B02)	07.2002 → 07.2009	841 C.000	D	23
2.2 JTD (179.AXN1B, 179.AXQ11, 179.BXN1B, 179.BXQ11)	04.2006 → 11.2010	4HR	D	41	3.0 V6 (841AXC1101)	07.2002 → 07.2009	841 A.000	B	51
2.2 JTD (179AXC1A)	09.2002 → 11.2010	4HW (DW12ATED4)	D	39	<b>TREVI (828_)</b>				
3.0 V6 (179.BXD11)	09.2002 → 11.2010	ES9 J4S	B	48	1600 (828DB03)	05.1980 → 01.1987	828 B.000	B	31
<b>PRISMA (831_)</b>					2000 (828.DB1)	05.1980 → 10.1984	828 B1.000	B	31
1.3 (831AB)	01.1983 → 12.1989	831 A2.000	B	44	2000 i.e. (828DB13)	05.1980 → 01.1987	828 B4.000	B	31
1.5 (831AB)	01.1983 → 04.1986	831 A1.000	B	44	<b>Y (840_)</b>				
1.5 (831AB)	09.1985 → 02.1992	138 C2.048	B	44	1.1 (840AE)	11.1995 → 09.2003	176 B2.000	B	6
1.6 (831AB)	01.1983 → 04.1986	831 A4.000	B	31	1.2 (840AA, 840AF1A)	03.1996 → 09.2003	188 A4.000	B	8
					1.2 (840AA, 840AF1A)	03.1996 → 09.2003	840 A3.000	B	8
					1.2 16V (840AD)	04.1997 → 09.2003	176 B9.000	B	9
					1.2 16V (840AG1A)	10.2000 → 09.2003	188 A5.000	B	9
					1.4 12V (840AB)	10.1996 → 09.2003	840 A2.000	B	18
					1.4 12V (840AC)	03.1996 → 09.2003	840 A4.000	B	18
					<b>Y10 (156_)</b>				
					1.0 (156C)	03.1985 → 07.1989	156 A.000	B	13
					1.0 Fire (156AA)	03.1985 → 06.1989	156 A2.000	B	6
					1.0 Fire (156AA, 156AD)	03.1985 → 02.1990	156 A2.000	B	6
					1.0 Fire (156B, 156AD)	06.1985 → 06.1991	156 A2.100	B	7
					1.0 Fire All-wheel Drive (156.AD)	12.1986 → 02.1989	156 A2.100	B	7
					1.0 Fire All-wheel Drive (156AA)	12.1987 → 02.1990	156 A2.000	B	6
					1.0 Fire All-wheel Drive (156AE)	12.1987 → 02.1992	156 A2.000	B	6
					1.0 Fire All-wheel Drive (156AE)	12.1987 → 02.1992	156 A2.246	B	6
					1.0 Fire Catalytic-Conv (156AE)	10.1987 → 02.1992	156 A2.246	B	6
					1.1 Fire (156AG)	01.1995 → 12.1995	176 B2.000	B	6
					1.1 Fire All-wheel Drive (156AG)	01.1995 → 12.1995	176 B2.000	B	6
					1.1 i.e Fire (156AC)	08.1989 → 06.1992	156 C.000	B	6



				Pos					Pos
1.1 i.e. Fire All-wheel Drive (156AC)	08.1989 → 06.1992	156 C.000	B	6					
1.1 i.e. Fire (156AG)	07.1989 → 09.1995	156 C.046	B	6					
1.1 i.e. Fire All-wheel Drive (156AG)	09.1992 → 12.1995	156 C.046	B	6					
<b>YPSILON (312_)</b>									
1.3 D Multijet (312.YXE1A, 312.YXU1A)	05.2011 →	199 B1.000	D	5					
<b>YPSILON (843_)</b>									
1.2 (843.AXA1A)	10.2003 → 12.2011	188 A4.000	B	8					
1.2 (843.AXB1A)	10.2003 → 12.2011	188 A5.000	B	9					
1.3 D Multijet (843.AXE11, 843.AXE1A)	09.2006 → 12.2011	199 A3.000	D	4					
1.3 D Multijet (843.AXF11, 843.AXF1A, 843.AXM11,....)	09.2006 → 12.2011	199 A2.000	D	3					
1.3 D Multijet (843.AXH1A, 843.AXE1A)	05.2007 → 12.2011	199 A3.000	D	4					
1.3 JTD (843.AXD11, 843.AXD1A)	10.2003 → 12.2011	188 A9.000	D	3					
1.4 (843.AXG1A)	02.2006 → 12.2011	350 A1.000	B	10					
1.4 LPG (843.AXG1A)	11.2010 → 12.2011	350 A1.000	B	10					
<b>ZETA (22_)</b>									
2.0 16V (220AQ5, 220AQ4)	07.2000 → 09.2002	RFN	B	35					
2.0 JTD (220.AR5, 220.AN5)	09.1999 → 09.2002	RHZ (DW10ATED)	D	37					
2.0 JTD 16V (220.AR5OOL)	04.2001 → 10.2003	RHW (DW10ATED4)	D	38					
2.1 TD (220AJ5)	05.1996 → 09.1999	P 8 C	D	36					

L

					Reference	Item No.	
<b>1</b>	<b>65</b>						
<b>A112 A.000</b>	03.1981 → 06.1986	B	(NA)	4	903 cm <sup>3</sup> 2V	21-32 kW (29-44 PS) 9	68,00 mm
<b>A112 A5.000</b>	03.1981 → 06.1986	B	(NA)	4	903 cm <sup>3</sup> 2V	29-31 kW (40-42 PS) 9	68,00 mm
<b>A112 B2.000</b>	03.1981 → 06.1986	B	(NA)	4	903 cm <sup>3</sup> 2V	29-32 kW (40-44 PS) 9	68,00 mm
[50]	∅ 7 mm						<b>RK-7</b>
IN/EX [4]	13,00 x 7 x 42,2	G1			4 372 331 4265699 6265699		<b>81-1755</b>
<b>2</b>	<b>67,2</b>						
<b>A112 B1.000</b>	03.1984 → 12.1986	B	(NA)	4	965 cm <sup>3</sup> 2V	35 kW (48 PS) 9,2	68,00 mm
[50]	∅ 7 mm						<b>RK-7</b>
IN/EX [4]	13,00 x 7 x 42,2	G1			4 372 331 4265699 6265699		<b>81-1755</b>
<b>3</b>	<b>69,6</b>						
<b>188 A9.000</b>	10.2003 → 09.2012	D	(NA)	4	1248 cm <sup>3</sup> 4V	51 kW (70 PS) 18	82,00 mm
<b>199 A2.000</b>	09.2006 → 12.2011	D	(LA)	4	1248 cm <sup>3</sup> 4V	55 kW (75 PS) 18	82,00 mm
41 289 6..							
IN [2]	21,9 x 6 x 109,3	S - Cr -	- 45° -	-	22 - III	46518930 55195680 55219965	<b>291111</b>
EX [2]	21,9 x 6 x 109,2	A/S - Cr -	- 45° -	-	22 - III	46518931 55202685 55208213	<b>291112</b>
[50]	∅ 6 mm						<b>MK-6H</b>
IN/EX [4]	10,03 x 6.02 x 43,0	G2				46816601	<b>81-4221</b>
	AS ES					46823507 46823508	<b>50 007 024</b> (1) <b>50 007 572</b> (1)
	(1) Schalenhartguss/chilled cast iron/pièce moulée trempée en surface/fundición en coquilla/Отливка с отбелсным поверхностным слоем						
[8]	H 12 x 34 x 34					46475925	<b>50 006 438</b>
[4]						73501138	<b>50 006 484</b>
<b>4</b>	<b>69,6</b>						
<b>199 A3.000</b>	09.2006 → 09.2012	D	(LA)	4	1248 cm <sup>3</sup> 4V	66-77 kW (90-105 PS) 18	82,00 mm
40 659 6..							
IN [2]	21,9 x 6 x 109,2	S - Cr -	- 45° -	-	22 - III		<b>291129</b>
EX [2]	22,5 x 6 x 109,2	A/S - Cr -	- 45° -	-	22 - III		<b>291130</b>
[50]	∅ 6 mm						<b>MK-6H</b>
IN/EX [4]	10,03 x 6.02 x 43,0	G2				46816601	<b>81-4221</b>
	AS ES					46823507 46823508	<b>50 007 024</b> (1) <b>50 007 572</b> (1)

Fortsetzung nächste Seite / continued on next page / suite page suivante / continuación página próxima / Продолжение на следующей странице

					Reference	Item No.	
(1)	Schalenhartguss/chilled cast iron/pièce moulée trempée en surface/fundición en coquilla/Отливка с отбеленным поверхностным слоем						
[8]	H 12 x 34 x 34				46475925	50 006 438	
[4]					73501138	50 006 484	
<b>5</b>	<b>69,6</b>						
<b>199 B1.000 Euro 5</b>	03.2009 →	D (LA)	4	1248 cm <sup>3</sup>	4V 57-70 kW (77-95 PS)	16,8 82,00 mm	
AS					55206897	50 007 799	
ES					55206898	50 007 800	
<b>6</b>	<b>70</b>						
<b>156 A2.000</b>	03.1985 → 02.1992	B (NA)	4	999 cm <sup>3</sup>	2V 33-37 kW (45-50 PS)	9,5-9,8 64,90 mm	
<b>156 A2.246</b>	10.1987 → 02.1992	B (NA)	4	999 cm <sup>3</sup>	2V 33 kW (45 PS)	9,5 64,90 mm	
<b>156 C.000</b>	08.1989 → 06.1992	B (NA)	4	1108 cm <sup>3</sup>	2V 42 kW (57 PS)	9-9,6 72,00 mm	
<b>156 C.046</b>	07.1989 → 12.1995	B (NA)	4	1108 cm <sup>3</sup>	2V 37-40 kW (50-54 PS)	9 72,00 mm	
<b>176 B2.000</b>	01.1995 → 09.2003	B (NA)	4	1108 cm <sup>3</sup>	2V 40 kW (54 PS)	9,6 72,00 mm	
94 910 7..							
EX [2]	27,5 x 7 x 97,1	A - Cr -		- 45° - VS -	1 -	5 942 728 5942728 7 666 227 7666227	17055
[50]	Ø 7 mm						RK-7
IN/EX [4]	13,00 x 7 x 42,2	G1				4 372 331 4265699 6265699	81-1755
<b>7</b>	<b>70</b>						
<b>156 A2.100</b>	06.1985 → 06.1991	B (NA)	4	999 cm <sup>3</sup>	2V 32 kW (44 PS)	9 64,90 mm	
IN/EX [4]	13,00 x 7 x 42,2	G1				4 372 331 4265699 6265699	81-1755
<b>8</b>	<b>70,8</b>						
<b>188 A4.000</b>	03.1996 → 12.2011	B (NA)	4	1242 cm <sup>3</sup>	2V 44 kW (60 PS)	10,6 78,90 mm	
<b>840 A3.000</b>	03.1996 → 09.2003	B (NA)	4	1242 cm <sup>3</sup>	2V 44 kW (60 PS)	9,8 78,90 mm	
94 870 7..							
IN/EX [4]	13,00 x 7 x 42,2	G1				4 372 331 4265699 6265699	81-1755
<b>9</b>	<b>70,8</b>						
<b>176 B9.000</b>	04.1997 → 09.2003	B (NA)	4	1242 cm <sup>3</sup>	4V 63 kW (86 PS)	10,2 78,90 mm	
<b>188 A5.000 Euro 3</b>	10.2000 → 12.2011	B (NA)	4	1242 cm <sup>3</sup>	4V 59 kW (80 PS)	10,6 78,90 mm	
IN [2]	26,8 x 6 x 95,0	S - Cr -		- 45° -	- 22 - III	46403681	171052
EX [2]	22,4 x 6 x 96,2	A - Cr -		- 45° -	- 22 -	46471639	171053
[8]	H 33 x 24 x 24					46787055 73503122	50 006 422
<b>10</b>	<b>72</b>						
<b>350 A1.000</b>	09.2005 → 09.2012	B (NA)	4	1368 cm <sup>3</sup>	2V 55-57 kW (75-78 PS)	11 84,00 mm	
Fortsetzung nächste Seite / continued on next page / suite page suivante / continuación página próxima / Продолжение на следующей странице							

					Reference	Item No.
IN [2]	33,2 x 5 x 99,9	S - Cr -	- 45° - -	22 - III	5 519 4219 5 520 0334 5 521 9143	<b>171117</b>
EX [2]	28,0 x 5 x 100,5	RA/S- Cr -	- 45° - VS -	22 - III	5 520 0335 5 520 0422 5 521 9144	<b>171118</b>
[50]	Ø 5 mm					<b>MK-5H</b>
<b>11</b>	<b>72</b>					
<b>192 B2.000</b>	10.2007 → 09.2012	B (NA)	4	1368 cm <sup>3</sup> 4V	66 kW (90 PS)	11 84,00 mm
[8]	H 28,4 x 26				55193839	<b>50 007 620</b>
<b>12</b>	<b>72</b>					
<b>198 A1.000</b>	09.2008 → 08.2014	B (A)	4	1368 cm <sup>3</sup> 4V	110 kW (150 PS)	9,6-10 84,00 mm
<b>198 A4.000</b>	09.2008 → 08.2014	B (A)	4	1368 cm <sup>3</sup> 4V	88 kW (120 PS)	9,6-10 84,00 mm
41 729 6..						
IN [2]	26,9 x 6 x 95,2	S - Cr -	- 45° - -	22 - III	55185028	<b>171125</b>
EX [2]	22,4 x 6 x 94,6	RA/S- Cr -	- 45° - VS -	22 - III	55185080	<b>171126</b>
[50]	Ø 6 mm					<b>MK-6H</b>
IN/EX [4]	10,05 x 5 x 46,5	G1				<b>81-4220</b>
[8]	H 28,4 x 26				55193839	<b>50 007 620</b>
<b>13</b>	<b>76,1</b>					
<b>156 A.000</b>	03.1985 → 07.1989	B (NA)	4	1049 cm <sup>3</sup> 2V	40-41 kW (54-56 PS)	9,5 57,80 mm
IN/EX [4]	13,00 x 7 x 42,2	G1			4 372 331 4265699 6265699	<b>81-1755</b>
<b>14</b>	<b>79,5</b>					
<b>198 A2.000</b>	09.2008 → 08.2014	D (LA)	4	1598 cm <sup>3</sup> 4V	88 kW (120 PS)	16,1-16,9 80,50 mm
<b>350 A2.000 Euro 5</b>	07.2008 → 09.2012	D (LA)	4	1598 cm <sup>3</sup> 4V	85-88 kW (116-120 PS)	16,5 80,50 mm
<b>955 A4.000</b>	08.2008 → 08.2014	D (LA)	4	1598 cm <sup>3</sup> 4V	85 kW (116 PS)	16,5 80,50 mm
IN [2]	27,8 x 5 x 114,4	S - Cr -	- 45° - -	22 - III	55206431	<b>291114</b>
IN [2]	27,8 x 6 x 114,4	S - Cr -	- 45° - -	22 - III	46802049 55195535 55202556	<b>291113</b>
EX [2]	24,2 x 5 x 114,3	A/S - Cr -	- 45° - -	22 - III	55205183	<b>291116</b>
EX [2]	25,8 x 6 x 114,4	A/S - Cr -	- 45° - VS -	22 - III	46787902 55202557	<b>291115</b>
[50]	Ø 5 mm					<b>MK-5H</b>
[50]	Ø 6 mm					<b>MK-6H</b>
IN/EX [4]	10,05 x 5 x 46,5	G1				<b>81-4220</b>
[8]	H 12 x 34 x 34				46475925	<b>50 006 438</b>
<b>15</b>	<b>79,5</b>					
<b>944 A 3.000</b>	04.2011 → 08.2014	D (LA)	4	1598 cm <sup>3</sup> 4V	77 kW (105 PS)	16,5 80,50 mm

Fortsetzung nächste Seite / continued on next page / suite page suivante / continuación página próxima / Продолжение на следующей странице

					Reference	Item No.
IN [2] EX [2]	26,6 x 5 x 114,4 24,2 x 5 x 114,3	S - Cr - A/S - Cr -	- 45° - - - 45° - -	22 - III 22 - III	55225891 55205183	171124 <b>NEW</b> 291116
[50]	Ø 5 mm					MK-5H
IN/EX [4]	10,05 x 5 x 46,5	G1				81-4220 <b>NEW</b>

## 16 80,5

**182 B6.000** 10.2000 → 10.2005 B (NA) 4 1596 cm<sup>3</sup> 4V 76 kW (103 PS) 10,1 78,40 mm  
41 933 6..

IN [2]	30,3 x 7 x 102,5	S - Cr -	- 45° - -	9 - III	4 641 3806 4 646 2158 4 651 7325 4 676 1369 5 518 3592 5 519 2067	171036
EX [2]	30,0 x 7 x 102,4	A/S - Cr -	- 45° - VS -	9 -	46 461 209	171037
[50]	Ø 7 mm					RK-7
[50]	Ø 8 mm					RK-8
IN/EX [4]	13,00 x 7 x 42,2	G1			4 372 331 4265699 6265699	81-1755
IN [4]	13,03 x 7 x 42,5	G2			608 11 086 60811086 7 756 897 7 757 052	81-17122
EX [4]	13,03 x 7 x 46,0	G2			608 11 089 7 779 402	81-17123
[8]	H 33 x 24 x 24				46787055 73503122	50 006 422

## 17 82

**838 A1.000** 10.1994 → 10.2001 B (NA) 5 1998 cm<sup>3</sup> 4V 107 kW (146 PS) 10 75,65 mm

IN [2]	30,0 x 7 x 113,2	S - Cr -	- 45° - -	22 - III	7 735 898	171005
EX [2]	26,0 x 7 x 108,8	A - Cr -	- 45° - VS -	22 -	7 735 899	171003
EX [2]	28,0 x 7 x 108,6	A - Cr -	- 45° - VS -	22 -	7 766 565	171004
[50]	Ø 7 mm					MK-7H
IN [4]	13,03 x 7 x 42,5	G2			608 11 086 60811086 7 756 897 7 757 052	81-17122
EX [4]	13,03 x 7 x 46,0	G2			608 11 089 7 779 402	81-17123

## 18 82

**840 A2.000** 10.1996 → 09.2003 B (NA) 4 1370 cm<sup>3</sup> 3V 55-59 kW (75-80 PS) 9,85 64,90 mm  
**840 A4.000** 03.1996 → 09.2003 B (NA) 4 1370 cm<sup>3</sup> 3V 55 kW (75 PS) 9,85 64,90 mm

[50]	Ø 7 mm					RK-7
IN [4]	13,03 x 7 x 42,5	G2			608 11 086 60811086 7 756 897 7 757 052	81-17122
EX [4]	13,03 x 7 x 46,0	G2			608 11 089 7 779 402	81-17123



					Reference	Item No.		
<b>19</b>	<b>82</b>							
<b>182 A2.000</b>	03.1996 → 08.1999	B (NA)	4	1747 cm <sup>3</sup>	4V	66-83 kW (90-113 PS)	10	82,70 mm
<b>182 B7.000</b>	07.1999 → 09.2000	B (NA)	5	1998 cm <sup>3</sup>	4V	113 kW (154 PS)	10,7	75,65 mm
<b>183 A1.000</b>	03.1996 → 08.1999	B (NA)	4	1747 cm <sup>3</sup>	4V	96 kW (131 PS)	10,3	82,70 mm
<b>838 A6.000</b>	07.1996 → 10.2001	B (NA)	5	1998 cm <sup>3</sup>	4V	114 kW (155 PS)	10,4	75,65 mm
<b>839 A4.000</b>	07.1999 → 10.2005	B (NA)	4	1747 cm <sup>3</sup>	4V	96 kW (131 PS)	10,3:1	82,70 mm
<b>839 A7.000</b>	09.2000 → 10.2005	B (NA)	4	1747 cm <sup>3</sup>	4V	96 kW (131 PS)	10,3	82,70 mm
<b>841 E.000</b>	07.2002 → 07.2009	B (LA)	5	1998 cm <sup>3</sup>	4V	136 kW (185 PS)	8,5	75,65 mm
	EX [2]	28,0 x 7 x 108,6	A - Cr -	- 45° - VS -	22 -	7 766 565		<b>171004</b>
	[50]	∅ 7 mm						<b>MK-7H</b>
	IN [4]	13,03 x 7 x 42,5	G2			608 11 086 60811086 7 756 897 7 757 052		<b>81-17122</b>
	EX [4]	13,03 x 7 x 46,0	G2			608 11 089 7 779 402		<b>81-17123</b>
	[8]	H 33 x 24 x 24				46787055 73503122		<b>50 006 422</b>
<b>20</b>	<b>82</b>							
<b>175 A3.000</b>	06.1998 → 10.2001	B (A)	5	1998 cm <sup>3</sup>	4V	162 kW (220 PS)	8,5	75,65 mm
	IN [2]	30,0 x 7 x 113,2	S - Cr -	- 45° -	22 - III	7 735 898		<b>171005</b>
	EX [2]	26,0 x 7 x 108,8	A - Cr -	- 45° - VS -	22 -	7 735 899		<b>171003</b>
	[50]	∅ 7 mm						<b>MK-7H</b>
	IN [4]	13,03 x 7 x 42,5	G2			608 11 086 60811086 7 756 897 7 757 052		<b>81-17122</b>
	EX [4]	13,03 x 7 x 46,0	G2			608 11 089 7 779 402		<b>81-17123</b>
	[8]	H 33 x 24 x 24				46787055 73503122		<b>50 006 422</b>
<b>21</b>	<b>82</b>							
<b>185 A8.000 Euro 3</b>	09.2000 → 10.2005	B (NA)	5	1998 cm <sup>3</sup>	4V	110 kW (150 PS)	10,5	75,70 mm
	IN [2]	30,0 x 7 x 113,2	S - Cr -	- 45° -	22 - III	7 735 898		<b>171005</b>
	EX [2]	26,0 x 7 x 108,8	A - Cr -	- 45° - VS -	22 -	7 735 899		<b>171003</b>
	EX [2]	28,0 x 7 x 108,6	A - Cr -	- 45° - VS -	22 -	7 766 565		<b>171004</b>
	[50]	∅ 7 mm						<b>MK-7H</b>
	IN [4]	13,03 x 7 x 42,5	G2			608 11 086 60811086 7 756 897 7 757 052		<b>81-17122</b>
	EX [4]	13,03 x 7 x 46,0	G2			608 11 089 7 779 402		<b>81-17123</b>
	[8]	H 33 x 24 x 24				46787055 73503122		<b>50 006 422</b>

					Reference	Item No.	
<b>22</b>		<b>82</b>					
<b>838 A3.000</b>	08.1994 → 10.2001	D (LA)	5	2387 cm <sup>3</sup>	2V	91 kW (124 PS) 21	90,40 mm
<b>838 A7.000</b>	08.1994 → 10.2001	D (LA)	5	2387 cm <sup>3</sup>	2V	91 kW (124 PS) 21	90,40 mm
	EX [2]	31,0 x 8 x 114,3	A/S - Cr -	- 45° - VS -	22 - III	4 652 7856 7 783 225	<b>171014</b>
	[50]	∅ 8 mm					<b>MK-8H</b>
	IN/EX [4]	14,03 x 8.02 x 43,0	G1			7565472	<b>81-17129</b>
	IN/EX [4]	14,06 x 8.02 x 43,0	G1			46433782	<b>81-17128</b>
<b>23</b>		<b>82</b>					
<b>838 A8.000</b>	06.1998 → 10.2001	D (A)	5	2387 cm <sup>3</sup>	2V	100 kW (136 PS) 18,45	90,40 mm
<b>839 A5.000</b>	07.1999 → 02.2001	D (LA)	5	2387 cm <sup>3</sup>	2V	96-99 kW (131-135 PS) 18,5	90,40 mm
<b>839 A6.000 Euro 3</b>	09.2000 → 10.2005	D (LA)	5	2387 cm <sup>3</sup>	2V	103 kW (140 PS) 18,45	90,40 mm
<b>841 C.000</b>	05.2002 → 07.2009	D (LA)	5	2387 cm <sup>3</sup>	2V	110 kW (150 PS) 18,5	90,40 mm
<b>937 A2.000</b>	05.2001 → 10.2005	D (LA)	4	1910 cm <sup>3</sup>	2V	85 kW (116 PS) 18,45:1	90,40 mm
<b>AR 32302</b>	07.1999 → 09.2001	D (A)	4	1910 cm <sup>3</sup>	2V	77 kW (105 PS) 18,5	90,40 mm
<b>AR 32501</b>	07.1999 → 02.2001	D (LA)	5	2387 cm <sup>3</sup>	2V	99-100 kW (135-136 PS) 18,5	90,40 mm
<b>AR 37101</b>	09.2000 → 05.2001	D (LA)	4	1910 cm <sup>3</sup>	2V	80-85 kW (109-116 PS) 18,5	90,40 mm
41 795 6..., 94 966 6...							
	IN [2]	35,5 x 8 x 115,0	A/S - Cr -	- 45° -	22 - III	46478834 46750859 55193126	<b>171046</b>
	EX [2]	34,5 x 8 x 115,1	A/S - Cr -	- 45° -	22 - III	46416321 46783962 55202630	<b>171062</b>
	[50]	∅ 8 mm					<b>MK-8H</b>
	IN/EX [4]	14,03 x 8.02 x 43,0	G1			7565472	<b>81-17129</b>
	IN/EX [4]	14,06 x 8.02 x 43,0	G1			46433782	<b>81-17128</b>
<b>24</b>		<b>82</b>					
<b>841 G.000</b>	05.2003 → 07.2009	D (LA)	5	2387 cm <sup>3</sup>	4V	129 kW (175 PS) 18,45:1	90,40 mm
<b>841 N.000</b>	09.2003 → 07.2009	D (LA)	5	2387 cm <sup>3</sup>	4V	120 kW (163 PS) 18,45:1	90,40 mm
40 660 6...							
	IN [2]	27,8 x 5 x 114,4	S - Cr -	- 45° -	22 - III	55206431	<b>291114</b>
	IN [2]	27,8 x 6 x 114,4	S - Cr -	- 45° -	22 - III	46802049 55195535 55202556	<b>291113</b>
	EX [2]	24,2 x 5 x 114,3	A/S - Cr -	- 45° -	22 - III	55205183	<b>291116</b>
	EX [2]	25,8 x 6 x 114,4	A/S - Cr -	- 45° - VS -	22 - III	46787902 55202557	<b>291115</b>
	[50]	∅ 5 mm					<b>MK-5H</b>
	[50]	∅ 6 mm					<b>MK-6H</b>
	IN/EX [4]	10,05 x 5 x 46,5	G1				<b>81-4220</b> <small>NEW</small>
	[8]	H 12 x 34 x 34				46475925	<b>50 006 438</b>
<b>25</b>		<b>82</b>					
<b>188 B2.000</b>	10.2004 → 09.2012	D (LA)	4	1910 cm <sup>3</sup>	2V	74 kW (101 PS) 18	90,40 mm
41 795 6...							
Fortsetzung nächste Seite / continued on next page / suite page suivante / continuación página próxima / Продолжение на следующей странице							

					Reference	Item No.
IN [2]	35,5 x 8 x 115,0	A/S - Cr -	- 45° - -	22 - III	46478834 46750859 55193126	<b>171046</b>
EX [2]	34,5 x 8 x 115,1	A/S - Cr -	- 45° - -	22 - III	46416321 46783962 55202630	<b>171062</b>
[50]	Ø 8 mm					<b>MK-8H</b>
IN/EX [4]	14,03 x 8.02 x 43,0	G1			7565472	<b>81-17129</b>
IN/EX [4]	14,06 x 8.02 x 43,0	G1			46433782	<b>81-17128</b>
					46772393	<b>50 007 038</b> <small>NEW</small> (1)
(1) Schalenhartguss/chilled cast iron/pièce moulée trempée en surface/fundición en coquilla/Отливка с отбеленным поверхностным слоем						
<b>26</b>	<b>82</b>	<b>844 A1.000</b> 01.2009 → 08.2014 D (LA) 4 1910 cm <sup>3</sup> 4V 140 kW (190 PS) 16,1-16, 90,40 mm <sub>9</sub>				
IN/EX [4]	10,05 x 5 x 46,5	G1				<b>81-4220</b> <small>NEW</small>
<b>27</b>	<b>82,6</b>	<b>831 D1.000</b> 05.1985 → 12.1989 D (LA) 4 1929 cm <sup>3</sup> 2V 48-59 kW (55-80 PS) 20 90,00 mm				
[50]	Ø 8 mm					<b>RK-8</b>
IN/EX [4]	14,07 x 8 x 46,0	G1			4 250 803	<b>81-17110</b>
IN [4]	14,10 x 8 x 42,0	G1			4 371 508	<b>81-1762</b>
<b>28</b>	<b>82,6</b>	<b>835 A4.000</b> 04.1989 → 08.1999 D (A) 4 1929 cm <sup>3</sup> 2V 66 kW (90 PS) 19,9 90,00 mm				
EX [2]	33,5 x 8 x 116,5	A - Cr -	- 45° - VS -	9 -	7 588 577 7588577	<b>17061</b>
[50]	Ø 8 mm					<b>RK-8</b>
<b>29</b>	<b>83</b>	<b>838 A2.000</b> 08.1994 → 10.2001 B (NA) 5 2446 cm <sup>3</sup> 4V 129 kW (175 PS) 10 90,40 mm				
<b>838 A2.027</b> 08.1994 → 10.2001 B (NA) 5 2446 cm <sup>3</sup> 4V 129 kW (175 PS) 10 90,40 mm						
<b>841 D.000</b> 07.2002 → 07.2009 B (NA) 5 2446 cm <sup>3</sup> 4V 125 kW (170 PS) 10,3 90,40 mm						
EX [2]	28,0 x 7 x 108,6	A - Cr -	- 45° - VS -	22 -	7 766 565	<b>171004</b>
[50]	Ø 7 mm					<b>MK-7H</b>
IN [4]	13,03 x 7 x 42,5	G2			608 11 086 60811086 7 756 897 7 757 052	<b>81-17122</b>
EX [4]	13,03 x 7 x 46,0	G2			608 11 089 7 779 402	<b>81-17123</b>

					Reference	Item No.		
<b>30</b>		<b>83</b>						
<b>198 A5.000</b>	09.2008 → 08.2014	D (LA)	4	1956 cm <sup>3</sup>	4V	121 kW (165 PS)	16,1-16,9 90,40 mm	
<b>844 A2.000</b>	09.2008 → 08.2014	D (A)	4	1956 cm <sup>3</sup>	4V	120 kW (163 PS)	16,5 90,40 mm	
41 070 6..								
	IN [2] IN [2]	27,8 x 5 x 114,4 27,8 x 6 x 114,4	S - Cr - S - Cr -	- 45° - - 45° -	- -	22 - III 22 - III	55206431 46802049 55195535 55202556	<b>291114</b> <b>291113</b>
	EX [2] EX [2]	24,2 x 5 x 114,3 25,8 x 6 x 114,4	A/S - Cr - A/S - Cr -	- 45° - - 45° -	- VS -	22 - III 22 - III	55205183 46787902 55202557	<b>291116</b> <b>291115</b>
	[50] [50]	∅ 5 mm ∅ 6 mm						<b>MK-5H</b> <b>MK-6H</b>
	IN/EX [4]	10,05 x 5 x 46,5	G1					<b>81-4220</b>
	[8]	H 12 x 34 x 34				46475925		<b>50 006 438</b>
<b>31</b>		<b>84</b>						
<b>828 B.000</b>	08.1973 → 01.1987	B (NA)	4	1585 cm <sup>3</sup>	2V	74 kW (100 PS)	9,3 71,50 mm	
<b>828 B1.000</b>	04.1976 → 10.1986	B (NA)	4	1995 cm <sup>3</sup>	2V	85-90 kW (116-122 PS)	8,9 90,00 mm	
<b>828 B4.000</b>	05.1980 → 01.1987	B (NA)	4	1995 cm <sup>3</sup>	2V	90 kW (122 PS)	8,9 90,00 mm	
<b>831 A4.000</b>	11.1982 → 04.1986	B (NA)	4	1585 cm <sup>3</sup>	2V	77 kW (105 PS)	9,5 71,50 mm	
<b>834 B.000</b>	11.1984 → 09.1988	B (NA)	4	1995 cm <sup>3</sup>	2V	88 kW (120 PS)	9,8 90,00 mm	
	[50]	∅ 8 mm						<b>RK-8</b>
	IN [4]	14,10 x 8 x 42,0	G1			4 371 508		<b>81-1762</b>
<b>32</b>		<b>84</b>						
<b>831 B3.000</b>	08.1986 → 08.1988	B (LA)	4	1585 cm <sup>3</sup>	2V	103 kW (140 PS)	8 71,50 mm	
	IN/EX [4]	10,05 x 5.99 x 45,0	G1					<b>81-4200</b>
<b>33</b>		<b>84</b>						
<b>834 B2.000</b>	05.1988 → 08.1992	B (NA)	4	1995 cm <sup>3</sup>	4V	108 kW (147 PS)	8:1 90,00 mm	
<b>834 F1.000</b>	05.1992 → 07.1994	B (NA)	4	1995 cm <sup>3</sup>	4V	110-112 kW (150-152 PS)	10,35:1 90,00 mm	
<b>834 F2.000</b>	10.1992 → 07.1994	B (LA)	4	1995 cm <sup>3</sup>	4V	148 kW (202 PS)	8:1 90,00 mm	
<b>836 A2.000</b>	06.1993 → 08.1999	B (LA)	4	1995 cm <sup>3</sup>	4V	137 kW (186 PS)	10 90,00 mm	
<b>836 A3.000</b>	06.1993 → 08.1999	B (NA)	4	1995 cm <sup>3</sup>	4V	102-108 kW (139-147 PS)	10 90,00 mm	
<b>838 A4.000</b>	02.1995 → 10.2001	B (A)	4	1995 cm <sup>3</sup>	4V	151 kW (205 PS)	8 90,00 mm	
	[50]	∅ 7 mm						<b>RK-7H</b>
	IN/EX [4]	14,04 x 7 x 51,3	G1			7 616 998		<b>81-17112</b>
<b>34</b>		<b>84</b>						
<b>175 A4.000</b>	07.1996 → 08.1999	B (A)	4	1995 cm <sup>3</sup>	4V	142 kW (193 PS)	8 90,00 mm	
	[50]	∅ 7 mm						<b>RK-7H</b>
	IN/EX [4]	14,04 x 7 x 51,3	G1			7 616 998		<b>81-17112</b>
Fortsetzung nächste Seite / continued on next page / suite page suivante / continuación página próxima / Продолжение на следующей странице								

					Reference	Item No.
[8]	H 33 x 24 x 24				46787055 73503122	50 006 422
<b>35</b>	<b>85</b>	<b>RFN</b> 07.2000 → 09.2002 B (NA) 4 1997 cm <sup>3</sup> 4V 100 kW (136 PS) 10,8 88,00 mm <b>RFN (EW10J4)</b> 09.2002 → 11.2010 B (NA) 4 1997 cm <sup>3</sup> 4V 100 kW (136 PS) 10,8 88,00 mm 40 309 6..				
IN [2] EX [2]	33,3 x 6 x 106,2 29,0 x 6 x 103,6	S - - A/S - Cr -	- 45° - - - 45° - VS -	1 - III 1 - III		<b>531010</b> <b>531011</b>
[50]						<b>KK-6H</b>
IN [4] EX [4]	12,11 x 6 x 40,8 12,06 x 6 x 40,8	B1 G2				<b>81-5333</b> <b>81-5334</b>
[8]	H 28,4 x 26 x 26					<b>50 006 480</b>
<b>36</b>	<b>85</b>	<b>P 8 C</b> 05.1996 → 09.1999 D (A) 4 2088 cm <sup>3</sup> 3V 80 kW (109 PS) 21,5 92,00 mm 94 643 6..				
[50]	Ø 8 mm					<b>MK-8H</b>
IN/EX [4]	13,07 x 8.01 x 54,5	B1				<b>81-5331</b>
<b>37</b>	<b>85</b>	<b>RHZ (DW10ATED)</b> 09.1999 → 09.2002 D (LA) 4 1997 cm <sup>3</sup> 2V 80 kW (109 PS) 18 88,00 mm 99 879 6..				
IN [2] EX [2]	35,6 x 6 x 107,1 33,8 x 6 x 107,1	S - Cr - A/S - Cr -	- 45° - - - 45° - -	22 - III 22 - III	9624774280 9624774580	<b>531003</b> <b>531004</b>
IN/EX [4]	10,52 x 6 x 41,5	G1				<b>81-5330</b>
						<b>50 006 389</b> (1)
	(1) Schalenhartguss/chilled cast iron/pièce moulée trempée en surface/fundición en coquilla/Отливка с отбелсным поверхностным слоем					
[8]	H 12 x 34,6 x 34,6				46767972 9464396380 9632372480	<b>50 006 432</b>
[4]					9623446280 9640296380	<b>50 006 430</b>
<b>38</b>	<b>85</b>	<b>RHW (DW10ATED4)</b> 04.2001 → 11.2010 D (LA) 4 1997 cm <sup>3</sup> 4V 80-81 kW (109-110 PS) 17,1 88,00 mm				
IN [2] EX [2]	30,0 x 6 x 105,0 25,0 x 6 x 105,0	S - Cr - A/S - Cr -	- 45° - - - 45° - VS -	22 - III 22 - III	9627184380 9634437580	<b>181104</b> <b>181105</b>
[50]	Ø 6 mm					<b>MK-6H</b>
IN/EX [4]	10,52 x 6 x 41,5	G1				<b>81-5330</b>
Fortsetzung nächste Seite / continued on next page / suite page suivante / continuación página próxima / Продолжение на следующей странице						







					Reference	Item No.
	ES AS					<b>50 007 010</b> <small>NEW</small> (1) <b>50 007 012</b> (1)
	(1) Schalenhartguss/chilled cast iron/pièce moulée trempée en surface/fundición en coquilla/Отливка с отбеленным поверхностным слоем					
[8]	H 12 x 34,6 x 34,6				46767972 9464396380 9632372480	<b>50 006 432</b>
[4]					9623446280 9640296380	<b>50 006 430</b>
<b>39</b>	<b>85</b>					
<b>4HW (DW12ATED4)</b> 09.2002 → 11.2010 D (LA) 4 2179 cm <sup>3</sup> 4V 94 kW (128 PS) 18 96,00 mm 40 406 6..						
IN [2]	27,3 x 6 x 96,0	S - Cr -	- 45° - -	22 - III		<b>539050</b> <small>NEW</small>
IN [2]	30,0 x 6 x 105,0	S - Cr -	- 45° - -	22 - III	9627184380	<b>181104</b>
EX [2]	24,7 x 6 x 95,0	RA/S- Cr -	- 45° - VS -	22 - III		<b>539051</b> <small>NEW</small>
EX [2]	25,0 x 6 x 105,0	A/S - Cr -	- 45° - VS -	22 - III	9634437580	<b>181105</b>
[50]	∅ 6 mm					<b>MK-6H</b>
IN/EX [4]	10,52 x 6 x 41,5	G1				<b>81-5330</b>
	ES AS					<b>50 007 088</b> <small>NEW</small> (1) <b>50 007 089</b> (1)
	(1) Schalenhartguss/chilled cast iron/pièce moulée trempée en surface/fundición en coquilla/Отливка с отбеленным поверхностным слоем					
[8]	H 12 x 33,5 x 33,5				9638075480	<b>50 006 435</b>
[4]						<b>50 006 096</b> (2)
	(2) mit Clip, with clip, avec clip, con clip, с брелоком-зажимом					
<b>40</b>	<b>85</b>					
<b>RHM (DW10ATED4)</b> 07.2003 → 11.2010 D (LA) 4 1997 cm <sup>3</sup> 4V 79 kW (107 PS) 17,6 88,00 mm						
[8]	H 12 x 34,5					<b>50 006 145</b>
[8]	H 12 x 34,5					<b>50 006 169</b>
[8]	H 12 x 33,5 x 33,5				9638075480	<b>50 006 435</b>
[4]						<b>50 006 096</b> (1)
	(1) mit Clip, with clip, avec clip, con clip, с брелоком-зажимом					
<b>41</b>	<b>85</b>					
<b>4HP</b>	04.2006 → 11.2010 D (LA) 4 2179 cm <sup>3</sup> 4V 120 kW (163 PS) 96,00 mm					
<b>4HR</b>	04.2006 → 11.2010 D (LA) 4 2179 cm <sup>3</sup> 4V 120 kW (163 PS) 17,6:1 96,00 mm					
IN [2]	27,3 x 6 x 96,0	S - Cr -	- 45° - -	22 - III		<b>539050</b> <small>NEW</small>
EX [2]	24,7 x 6 x 95,0	RA/S- Cr -	- 45° - VS -	22 - III		<b>539051</b> <small>NEW</small>
[50]	∅ 6 mm					<b>MK-6H</b>

L

					Reference	Item No.	
<b>42</b>	<b>85</b>						
<b>RHK (DW10UTED4)</b>	06.2006 → 11.2010	D (LA)	4	1997 cm <sup>3</sup> 4V	79-88 kW (107-120 PS)	17,5 88,00 mm	
<b>Euro 4</b>							
<b>RHR (DW10BTED4)</b>	07.2006 → 11.2010	D (LA)	4	1997 cm <sup>3</sup> 4V	100 kW (136 PS)	18 88,00 mm	
<b>Euro 4</b>							
99 700 6..							
	IN [2] EX [2]	30,0 x 6 x 105,0 25,0 x 6 x 105,0	S - Cr - A/S - Cr -	- 45° - - - 45° - VS -	22 - III 22 - III	9627184380 9634437580	<b>181104</b> <b>181105</b>
	[50]	∅ 6 mm					<b>MK-6H</b>
	IN/EX [4]	10,52 x 6 x 41,5	G1				<b>81-5330</b>
		ES AS					<b>50 007 010</b> <small>NEW</small> (1) <b>50 007 012</b> (1)
	(1)	Schalenhartguss/chilled cast iron/pièce moulée trempée en surface/fundición en coquilla/Отливка с отбеленным поверхностным слоем					
	[8] [8] [8]	H 12 x 34,5 H 12 x 34,5 H 12 x 33,5 x 33,5				9638075480	<b>50 006 169</b> <b>50 006 145</b> <b>50 006 435</b>
	[4]						<b>50 006 096</b> (2)
	(2)	mit Clip, with clip, avec clip, con clip, с брелоком-зажимом					
<b>43</b>	<b>85</b>						
<b>4HT Euro 4</b>	03.2008 → 11.2010	D (LA)	4	2179 cm <sup>3</sup> 4V	125 kW (170 PS)	17,5 96,00 mm	
	IN [2] EX [2]	27,3 x 6 x 96,0 24,7 x 6 x 95,0	S - Cr - RA/S- Cr -	- 45° - - - 45° - VS -	22 - III 22 - III		<b>539050</b> <small>NEW</small> <b>539051</b> <small>NEW</small>
	[50]	∅ 6 mm					<b>MK-6H</b>
	IN/EX [4]	10,52 x 6 x 41,5	G1				<b>81-5330</b>
<b>44</b>	<b>86,4</b>						
<b>138 C2.048</b>	09.1985 → 02.1992	B (NA)	4	1498 cm <sup>3</sup> 2V	55 kW (75 PS)	9-9,2 63,90 mm	
<b>831 A1.000</b>	09.1979 → 04.1986	B (NA)	4	1498 cm <sup>3</sup> 2V	63 kW (86 PS)	9,2 63,90 mm	
<b>831 A2.000</b>	09.1979 → 08.1992	B (NA)	4	1301 cm <sup>3</sup> 2V	55-58 kW (75-79 PS)	9,5 55,50 mm	
<b>831 B.000</b>	09.1979 → 08.1992	B (NA)	4	1301 cm <sup>3</sup> 2V	55 kW (75 PS)	9,5 55,50 mm	
	[50]	∅ 8 mm					<b>RK-8</b>
	IN/EX [4] IN [4]	14,07 x 8 x 46,0 14,10 x 8 x 42,0	G1 G1			4 250 803 4 371 508	<b>81-17110</b> <b>81-1762</b>
<b>45</b>	<b>86,4</b>						
<b>835 A1.000</b>	08.1989 → 06.1994	B (NA)	4	1581 cm <sup>3</sup> 2V	65-66 kW (88-90 PS)	9,2 67,40 mm	
	IN [2]	39,5 x 8 x 108,5	S - Cr -	- 45° - -	1 - III	7 617 500	<b>17089</b>
	[50]	∅ 8 mm					<b>RK-8</b>
	IN/EX [4] IN [4]	14,07 x 8 x 46,0 14,10 x 8 x 42,0	G1 G1			4 250 803 4 371 508	<b>81-17110</b> <b>81-1762</b>

					Reference	Item No.	
<b>46</b>		<b>86,4</b>					
<b>182 A4.000</b>	01.1996 → 10.2005	B (NA) 4	1581 cm <sup>3</sup> 4V	76 kW	(103 PS) 10,2	67,40 mm	
	IN [2]	30,3 x 7 x 102,5	S - Cr -	- 45° - -	9 - III	4 641 3806 4 646 2158 4 651 7325 4 676 1369 5 518 3592 5 519 2067	<b>171036</b>
	EX [2]	30,0 x 7 x 102,4	A/S - Cr -	- 45° - VS -	9 -	46 461 209	<b>171037</b>
	EX [2]	30,0 x 7 x 102,8	A - Cr -	- 45° - -	9 -	4 641 3807 4 646 2159 4 676 1370 5 519 6738	<b>171043</b>
	[50]	∅ 7 mm					<b>RK-7</b>
	[50]	∅ 8 mm					<b>RK-8</b>
	IN/EX [4]	13,00 x 7 x 42,2	G1			4 372 331 4265699 6265699	<b>81-1755</b>
	IN [4]	13,03 x 7 x 42,5	G2			608 11 086 60811086 7 756 897 7 757 052	<b>81-17122</b>
	EX [4]	13,03 x 7 x 46,0	G2			608 11 089 7 779 402	<b>81-17123</b>
	[8]	H 33 x 24 x 24				46787055 73503122	<b>50 006 422</b>
<b>47</b>		<b>86,4</b>					
<b>182 A6.000</b>	03.1996 → 08.1999	B (NA) 4	1581 cm <sup>3</sup> 4V	66 kW	(90 PS) 10,1	67,40 mm	
	IN [2]	30,3 x 7 x 102,5	S - Cr -	- 45° - -	9 - III	4 641 3806 4 646 2158 4 651 7325 4 676 1369 5 518 3592 5 519 2067	<b>171036</b>
	EX [2]	30,0 x 7 x 102,4	A/S - Cr -	- 45° - VS -	9 -	46 461 209	<b>171037</b>
	EX [2]	30,0 x 7 x 102,8	A - Cr -	- 45° - -	9 -	4 641 3807 4 646 2159 4 676 1370 5 519 6738	<b>171043</b>
	[50]	∅ 7 mm					<b>RK-7</b>
	[50]	∅ 8 mm					<b>RK-8</b>
	IN/EX [4]	13,00 x 7 x 42,2	G1			4 372 331 4265699 6265699	<b>81-1755</b>
	[8]	H 33 x 24 x 24				46787055 73503122	<b>50 006 422</b>
<b>48</b>		<b>87</b>					
<b>ES9 J4S</b>	09.2002 → 11.2010	B (NA) 6	2946 cm <sup>3</sup> 4V	150 kW	(204 PS) 10,9	82,60 mm	
	IN [2]	35,0 x 6 x 108,5	S - -	- 45° - -	1 - III	9630441380	<b>539022</b>
	EX [2]	30,5 x 6 x 107,0	A/S - Cr -	- 45° - VS -	1 - III	9640181380	<b>539023</b>
	[50]	∅ 6 mm					<b>LK-6H</b>

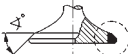
					Reference	Item No.	
<b>49</b>	<b>91</b>						
<b>834 E.146</b>	11.1984 → 05.1992	B (NA)	6	2849 cm <sup>3</sup> 2V	108-110 kW (147-150 PS)	9,5:1 73,00 mm	
	EX [6]	14,07 x 9 x 42,5	G1		7902101354 7902101355	<b>81-5609</b>	
<b>50</b>	<b>93</b>						
<b>834 F.000</b>	08.1992 → 07.1994	B (NA)	6	2959 cm <sup>3</sup> 2V	126 kW (171 PS)	9,5:1 72,60 mm	
	EX [6]	14,07 x 9 x 42,5	G1		7902101354 7902101355	<b>81-5609</b>	
<b>51</b>	<b>93</b>						
<b>838 B.000</b>	10.1994 → 10.2001	B (NA)	6	2959 cm <sup>3</sup> 4V	150 kW (204 PS)	10 72,60 mm	
<b>841 A.000</b>	07.2002 → 07.2009	B (NA)	6	2959 cm <sup>3</sup> 4V	158 kW (215 PS)	10 72,60 mm	
	EX [4]	12,07 x 7.01 x 43,0	G1			<b>81-5610</b>	
<b>52</b>	<b>93</b>						
<b>8144.97S</b>	05.1988 → 07.1992	D (A)	4	2500 cm <sup>3</sup> 2V	77 kW (105 PS)	21 92,00 mm	
<b>8144.91</b>	11.1984 → 09.1990	D (A)	4	2445 cm <sup>3</sup> 2V	74 kW (101 PS)	22 90,00 mm	
	IN [2]	41,0 x 8 x 120,8	S - Cr -	- 30° - -	9 - III	47 57 358 504069200 7 301 820	<b>171120</b>
	EX [2]	36,0 x 8 x 122,0	A/S - Cr -	- 45° - -	9 - III	99432837	<b>171055</b>
	[50]	∅ 8 mm					<b>RK-8</b>
	[50]	∅ 8 mm					<b>RK-8H</b>
	IN/EX [4]	13,02 x 8.02 x 56,0	G1			4 749 395	<b>81-17116</b>
	IN/EX [4]	13,07 x 8.02 x 56,0	G1			4 749 397	<b>81-17115</b>
	IN/EX [4]	13,07 x 8.02 x 60,0	G1			4 726 483	<b>81-17114</b> (1)
	IN/EX [4]	13,12 x 8 x 56,0	G1			4 733 258 4 749 398	<b>81-5611</b>
	(1) ohne Ventilschaftabdichtung/without valve stem gasket/sans joint de tige de soupape/sin junta de vástago de válvula/без уплотнения стержня клапана						
	[8]	M 44 x 32				4733350	<b>50 006 180</b>
<b>53</b>	<b>93</b>						
<b>8144.97</b>	06.1988 → 05.1992	D (A)	4	2499 cm <sup>3</sup> 2V	85 kW (115 PS)	22 92,00 mm	
<b>8144.97 Y</b>	05.1992 → 07.1994	D (A)	4	2500 cm <sup>3</sup> 2V	85 kW (115 PS)	22,5 92,00 mm	
	IN [2]	41,0 x 8 x 120,8	S - Cr -	- 30° - -	9 - III	47 57 358 504069200 7 301 820	<b>171120</b>
	EX [2]	34,5 x 8 x 122,0	A/S - Cr -	- 45° - -	9 - III	4 826 033 7 301 821	<b>17063</b>
	EX [2]	36,0 x 8 x 122,0	A/S - Cr -	- 45° - -	9 - III	99432837	<b>171055</b>
	[50]	∅ 8 mm					<b>RK-8</b>
	[50]	∅ 8 mm					<b>RK-8H</b>
	IN/EX [4]	13,02 x 8.02 x 56,0	G1			4 749 395	<b>81-17116</b>
	IN/EX [4]	13,07 x 8.02 x 56,0	G1			4 749 397	<b>81-17115</b>
	IN/EX [4]	13,07 x 8.02 x 60,0	G1			4 726 483	<b>81-17114</b> (1)
	IN/EX [4]	13,12 x 8 x 56,0	G1			4 733 258 4 749 398	<b>81-5611</b>
	(1) ohne Ventilschaftabdichtung/without valve stem gasket/sans joint de tige de soupape/sin junta de vástago de válvula/без уплотнения стержня клапана						
Fortsetzung nächste Seite / continued on next page / suite page suivante / continuación página próxima / Продолжение на следующей странице							

					Reference	Item No.
 [8]	M 44 x 32				4733350	50 006 180

L



								Comp. Ratio			
			Cyl.	mm	cm <sup>3</sup>		ε	kW	PS	Pos	
4-390		D (NA)	4	102 x 120	3922	2	8,8	59-110	80-150	250	
CO 3 D VAR.1		D (NA)	4	110 x 130	4940	2	17,2:1	63	86	315	
M 102	938	B (NA)	4	89 x 80,25	1997	2	8:1	63	86	80	
M 102	921	B (NA)	4	89 x 80,3	1996	2	9:1	63-77	86-105	80	
M 102	939	B (NA)	4	89 x 80,25	1997	2	8	74-80	100-109	78	
M 102	920, 961	B (NA)	4	89 x 80,3		2		74-93	100-126	78	
M 102	922, 924, 965	B (NA)	4	89 x 80,25	1996	2		75-85	102-116	79	
M 102	910, 919	B (NA)	4	89 x 72,2	1797	2		77-80	105-109	79	
M 102	962, 964	B (NA)	4	89 x 80,3		2	9,1	80-90	109-122	79	
M 102	963	B (NA)	4	89 x 80,2	1996	2	9,1	87-90	118-122	79	
M 102	942 - 943, 959, 980 - 981, 998	B (NA)	4	95,5 x 80,25	2299	2		70-100	95-136	118	
M 102	945 - 946, 958, 979, 982, 985, 987, 996 - 997	B (NA)	4	95,5 x 80,25	2299	2		70-100	95-136	119	
M 102	989	B (NA)	4	95,5 x 80,3	2298	2	9	93	126	119	
M 102	983	B (NA)	4	95,5 x 80,25	2299	4	10,5	125-136	170-185	120	
M 102	990 - 991	B (NA)	4	95,5 x 87,2	2498	4	9,7	143-150	195-204	121	
M 102	992	B (NA)	4	95,5 x 87,2	2498	2	9,7	173	235	121	
M 103	940, 942 - 943	B (NA)	6	82,9 x 80,3	2597	2		118-122	160-166	28	
M 103	941	B (NA)	6	82,9 x 80,25	2599	2	9,2	118-122	160-166	28	
M 103	980 - 985, 987	B (NA)	6	88,5 x 80,25	2960	2		125-140	170-190	76	
M 104	900	B (NA)	6	81 x 90,3	2792	2	10,1	128	174	15	
M 104	980 - 981	B (NA)	6	88,5 x 80,2	2960	4	10	162-170	220-231	77	
M 104	941 - 945	B (NA)	6	89,9 x 73,5	2799	4	10	142-150	193-204	91	
M 104	991 - 992, 994 - 996	B (NA)	6	89,9 x 84	3199	4	10	155-170	211-231	91	
M 104	990	B (NA)	6	89,9 x 84	3199	4	10	162-170	220-231	90	
M 104	941 (AMG 3.6), 992 (AMG 3.6)	B (NA)	6	91 x 92,4	3606	4		195-206	265-280	104	
M 104	996 (AMG 3.6)	B (NA)	6	91 x 92,4	3606	4	10	200	272	105	
M 108	920, 924	B (NA)	6	82 x 78,8	2496	2		85-96	116-131	20	
M 110	921 - 923, 931 - 932, 981 - 986, 991 - 992	B (NA)	6	86 x 78,8	2746	2		101-136	137-185	53	
M 110	924, 926, 987 - 990, 994	B (NA)	6	86 x 78,8	2746	2		110-136	150-185	54	
M 111	920 - 921	B (NA)	4	85,3 x 78,7	1799	4		89-90	121-122	52	
M 111	952	B (NA)	4	89,9 x 78,7	1998	4	10,6	95	129	97	
M 111	951	B (K)	4	89,9 x 78,7	1998	4	10,6	95	129	97	
M 111	942, 945 - 946, 948, 950	B (NA)	4	89,9 x 78,7	1998	4		95-100	129-136	93	
M 111	940 - 941	B (NA)	4	89,9 x 78,7	1998	4		100	136	89	
M 111	960 - 961	B (NA)	4	89,9 x 86,6	2199	4		110	150	92	
M 111	955 - 958	B (K)	4	89,9 x 78,7	1998	4	9,5	120	163	96	
M 111	943 - 944, 947	B (K)	4	89,9 x 78,7	1998	4		132-141	180-192	94	
M 111	984	BG (NA)	4	90,9 x 88,4	2295	4	8,8	92-105	125-143	98	
M 111 KAT	979	BG (NA)	4	90,9 x 88,4	2295	4	8,8	95-105	129-143	98	
M 111	978, 980	B (NA)	4	90,9 x 88,4	2295	4	8,8	105	143	100	
M 111	970, 974, 977	B (NA)	4	90,9 x 88,4	2295	4	10,4	110	150	99	
M 111	973, 975	B (K)	4	90,9 x 88,4	2295	4	8,8	138-142	188-193	99	
M 111	981 - 983	B (K)	4	90,9 x 88,4	2295	4	9	143-145	194-197	101	
M 111/1A		B	6	82 x 72,4	2294	2	9:1	77	105	20	
M 112	910 - 911	B (NA)	6	83,2 x 73,5	2398	3		125	170	47	
M 112	912 - 917	B (NA)	6	89,9 x 68,2	2597	3		120-130	163-177	95	
M 112	940 - 947, 949, 951, 953 - 955	B (NA)	6	89,9 x 84	3199	3	10	140-165	190-224	95	
M 112	920 - 923	B (NA)	6	89,9 x 73,5	2799	3	10	145-150	197-204	95	
M 112	960 - 961	B (K)	6	89,9 x 84	3199	3		260	354	95	
M 112	970, 972 - 973, 975 - 976	B (NA)	6	97 x 84	3724	3	10	165-180	224-245	127	
M 113	940 - 944, 948	B (NA)	8	89,9 x 84	4266	3	10	199-225	271-306	95	
M 113	960 - 969, 971	B (NA)	8	97 x 84	4966	3		215-225	292-306	127	
M 113	962 AMG	B	8	97 x 92	5439	3	10,5:1	255-260	347-354	127	
M 113	980 - 982, 984, 986 - 989	B (NA)	8	97 x 92	5439	3		255-294	347-400	127	
M 113	990 - 993, 995	B (K)	8	97 x 92	5439	3	9	349-380	475-517	127	
M 114	920, 980	B (NA)	6	82 x 78,8	2496	2		85-110	116-150	20	
M 114	923, 981	B	6	82 x 78,8	2496	2		85-110	116-150	20	
M 115	900, 920 - 921, 924, 927 - 929	B (NA)	4	87 x 92,4	2197	2		40-77	54-105	58	
M 115	922, 932 - 935	B	4	87 x 92,4	2197	2	9:1	48-62	65-85	58	
M 115	I, II	B	4	87 x 83,6	1990	2	9	55-63	75-85	58	
M 115	923, 926, 938 - 939	B (NA)	4	87 x 83,6	1988	2	9	62-70	84-95	58	
M 115	951 - 952, 954 - 955, 958, 970 - 973	B (NA)	4	93,75 x 83,6	2307	2		59-81	80-110	117	
M 115	974	B	4	93,75 x 83,6	2307	2	8:1	66	90	117	
M 116	962 - 963	B (NA)	8	88 x 78,9	3839	2	9,4	116-150	158-204	66	
M 116	961 (SUI), 961 (USA)	B	8	88 x 78,9	3818	2	8,3:1	120-145	163-197	66	
M 116	960 - 961	B (NA)	8	92 x 71,8	3818	2	9	120-160	163-218	108	
M 116	980 - 982, 984 - 985, 990 - 993	B (NA)	8	92 x 65,8	3499	2		132-152	180-205	107	
M 116	983	B	8	92 x 65,8	3499	2	9,5	147	200	107	

			Cyl.		mm	cm <sup>3</sup>		Comp. Ratio $\epsilon$	kW	PS	Pos
M 116	964 - 965	B (NA)	8		92 x 78,9	4196	2		150-170	204-231	109
M 117	981 - 986, 992 - 993	B (NA)	8		92 x 85	4520	2		119-165	162-225	107
M 117	962 - 965	B (NA)	8		96,5 x 85	4973	2		164-195	223-265	123
M 117	967 - 968	B (NA)	8		96,5 x 94,8	5547	2	10	169-220	230-300	124
M 117	960 - 961	B (NA)	8		96,5 x 85	4973	2	8,8	170-180	231-245	122
M 119	971, 975, 981, 985	B (NA)	8		92 x 78,9	4196	4		205-214	279-291	110
M 119	960, 970, 972, 974, 980, 982, 985 (AMG 5.0)	B (NA)	8		96,5 x 85	4973	4		235-255	320-347	125
M 120	000 - 002, 010 - 011	B	4		75 x 100	1767	2	6,7:1	38	52	4
M 120	980 - 983	B (NA)	12		89 x 80,2	5987	4		270-300	381-408	81
M 121	924	B (NA)	4		84,5 x 84	1884	2	8,8	59	80	50
M 121	922	B	4		85 x 83,6	1897	2	8,5:1	48	65	51
M 121	926, 929	B (NA)	4		85 x 83,6	1897	2	8,8:1	50-59	68-80	51
M 121	941 - 942, 944	B	4		87 x 83,6	1988	2	9:1	50-59	68-80	58
M 121	940, 943	B (NA)	4		87 x 83,6	1988	2		59-61	80-83	58
M 123	920 - 921	B (NA)	6		86 x 72,5	2525	2		95-103	129-140	55
M 127	983	B	6		80 x 72,8	2196	2	8,7:1	85	115	9
M 127	980, 982, 984	B (NA)	6		80 x 72,8		2		88	120	9
M 127	981	B (NA)	6		82 x 72,8	2306	2	9,3	110	150	19
M 127	945, 949	B	6		82 x 72,8	2307	2	9,3:1	110-111	150	20
M 129	980 - 982	B (NA)	6		82 x 78,8	2496	2	9,3	110	150	20
M 130	921, 924 - 925, 933	B	6		86,5 x 78,8	2778	2		81-92	110-125	57
M 130	920, 922 - 923, 980 - 981, 983 - 984	B (NA)	6		86,5 x 78,8		2		96-125	130-170	57
M 136	920	B (NA)	4		73,5 x 100	1697	2	6,7	33	45	2
M 136	040, 042 - 044, 047 - 055, 060, 071 - 073, 921, 923, 926	B	4		75 x 100	1767	2		33-38	45-52	4
M 136	922	B (NA)	4		75 x 100	1767	2	6,7	38	52	4
M 136	925	B (NA)	4		84,5 x 84	1884	2	6,7	48	65	49
M 157	980 - 981, 983	B (LA)	8		98 x 90,5	5461	4		386-430	525-585	237
M 166	940	B (NA)	4		80 x 69,5	1397	2	11	60	82	10
M 166	960 - 961	B (NA)	4		80 x 79,5	1598	2	11	60-75	82-102	11
M 166	990 - 991	B (NA)	4		84 x 85,6	1898	2	10,8	92	125	48
M 166	995	B (NA)	4		84 x 94	2084	2	11	103	140	48
M 180	958	B (NA)	6		80 x 72,8	2196	4	8,7:1	60	82	9
M 180	922, 926 - 929, 940 - 943, 952 - 953	B (NA)	6		80 x 72,8	2195	2		60-81	82-110	9
M 180	945, 947, 949	B (NA)	6		81,5 x 73	2281	2	9	77-88	105-120	16
M 180	950	B	6		81,5 x 73	2281	2	9	88	120	16
M 180	951	B (NA)	6		82 x 72,8	2306	2	9:1	79	107	20
M 180	954 - 955	B (NA)	6		82 x 72,4	2292	2		88	120	20
M 191	010, 018	B	4		75 x 100	1767	2	6,5/6,7:1	33-38	45-52	4
M 200	711	B (LA)	4		72,2 x 73,1	1197	4		84	114	1
M 260	920	B (A)	4		83 x 92	1991	4		140-225	190-306	32
M 264 Euro 6	915	B (A)	4		80,4 x 73,7	1497	4		95-145	129-197	14
M 264 Euro 6	920	B (LA)	4		83 x 92	1991	4	10	145-220	197-299	32
M 266	920	B (NA)	4		83 x 69,2	1498	2	11	70	95	30
M 266	940	B (NA)	4		83 x 78,5	1699	2	11	85	116	30
M 266	960	B (NA)	4		83 x 94	2034	2	11	85-100	116-136	30
M 266	980	B (A)	4		83 x 94	2034	2	11	142	193	30
M 270	910	B (A)	4		83 x 73,7	1595	4	10,3	75-115	102-156	31
M 270	920	BG (A)	4		83 x 92	1991	4	10,3:1	115-160	156-218	29
M 271	921, 940 - 942, 944, 946, 948, 956	B (K)	4		82 x 85		4		90-141	122-192	21
M 271	911	B (NA)	4		82 x 75,6	1597	4	10	95	129	25
M 271	910	B (K)	4		82 x 75,6	1597	4	10	105-115	143-156	23
M 271	951	BG (NA)	4		82 x 85	1796	4	9,5	115	156	17
M 271	950, 952, 954	B (K)	4		82 x 85	1796	4	9,5	115-135	156-184	23
M 271	820, 860	B (A)	4		82 x 85	1796	4	9,3	115-150	156-204	24
M 271	958	BG (K)	4		82 x 85	1796	4	9,5	120-135	163-184	18
M 271	957	B (K)	4		82 x 85	1796	4	9,3	120-135	163-184	25
M 271	955	B (K)	4		82 x 85	1796	4	9,3	135	184	22
M 271	861	B (LA)	4		82 x 85	1796	4	9,3	135-150	184-204	24
M 272	923	B	6		82 x 78,8	2496	4				26
M 272	911, 920 - 922	B (NA)	6		88 x 68,4	2496	4	11,2	150	204	67
M 272	940 - 949, 952	B (NA)	6		88 x 82,1	2996	4		161-180	219-245	67
M 272	960 - 961, 963 - 967, 970 - 972, 975, 978, 980, 988	B (NA)	6		92,9 x 86	3498	4		170-215	231-292	111
M 272	968 - 969, 974, 977, 979, 982 - 985	B (NA)	6		92,9 x 86	3498	4		190-232	258-316	112
M 272	991	B (NA)	6		92,9 x 86	3498	4	12,2	200	272	114
M 273	922 - 924	B (NA)	8		92,9 x 86	4663	4		250	340	111

M

					Cyl.	mm	cm <sup>3</sup>	ε	kW	PS	Pos
M 273	960 - 963, 965 - 968, 970 - 971	B (NA)	8	98 x 90,5	5461	4	10,7	271-320	369-435	237	
M 274	910	B (A)	4	83 x 73,7	1595	4	10,3	95-115	129-156	31	
M 274	920	BG (LA)	4	83 x 92	1991	4	9,8	115-245	156-333	29	
M 276	950, 952, 955 - 958	B (NA)	4	92,9 x 86	3498	4	12,2	182-245	248-333	113	
M 278 Euro 5	928	B (LA)	8	92,9 x 86	4663	4	10,5	270-335	367-456	113	
M 278 Euro 5	920, 922, 927, 932	B (LA)	8	92,9 x 86	4663	4	10,5	300-335	408-455	115	
M 278 Euro 5	929	B (LA)	8	92,9 x 86	4663	4	10,5	320-338	435-460	116	
M 343	920	AL	4	97 x 128	3780	2	17:1	70	95	128	
M 352	921, 923 - 924, 929	B	6	97 x 128	5675	2		93	126	126	
M 372 Euro 0	926 - 927, 929	G	6	97,5 x 133	5958	2		63-110	85-150	184	
M 372 Euro 0	924	G	6	97,5 x 133	5958	2		110	150	183	
M 376	922 - 924	G (LA)	6	97,5 x 133	5958	2		155-157	211-214	182	
M 447	925	G	6	128 x 155	11970	2	18:1	150	204	354	
M 476 Euro 2	936	G (LA)	6	128 x 155	11967	2		175	238	357	
M 476	920 - 921	G (LA)	6	128 x 155	11967	2		175-177	238-241	356	
M 476	925 - 927	G (LA)	6	128 x 155	11967	2		177	241	355	
M 476 Euro 2	937	G (LA)	6	128 x 155	11967	2		185	252	358	
M 476 Euro 2	930, 932 - 935	G (LA)	6	128 x 155	11967	2		185-240	252-326	356	
M 902 Euro 5	900, 902 - 903	G (LA)	6	106 x 130	6883	3	10,5:1	170-205	231-279	277	
M 902 Euro 5	901	G (LA)	6	106 x 130	6883	3	10,5:1	170-205	231-279	278	
M 906 Euro 5	901	G (LA)	6	106 x 130	6883	3	10,5:1	170	231	280	
M 906 Euro 5	900, 903	G (LA)	6	106 x 130	6883	3	10,5:1	205	279	279	
OM 304	900-001, 900-010	D (A)	4	97,5 x 133	3972	2	16,5:1	61	83	232	
OM 304	900-401, 900-410	D (A)	4	97,5 x 133	3972	2	16,5:1	85	115	211	
OM 306 Euro 0	900-016 (ZA), 900-017 (ZA), 900-018 (ZA)	D (A)	6	97,5 x 133	5958	2	16,5:1	92	125	206	
OM 306 Euro 0	900-417	D (A)	6	97,5 x 133	5958	2	16,5:1	125	170	228	
OM 306 Euro 0	900-413 (ZA), 900-414, 900-415, 900-416 (ZA)	D (A)	6	97,5 x 133	5958	2	16,5:1	125	170	227	
OM 306 Euro 0	900-510 (ZA)	D (LA)	6	97,5 x 133	5958	2		177	240	227	
OM 314	958, 960	D (NA)	4	97 x 128	3782	2	17:1	35-62	48-84	172	
OM 314	900-000, 900-001, 900-002, 900-003, 900-004, 900-005, 900-006, 900-007, 900-008, 900-010, 900-011, 900-012, 900-013, 900-014, 900-015, 900-016, 900-017, 900-018, 900-019, 900-020, 900-021, 900-022, 900-023, 900-024, 900-025	D	4	97 x 128	3780	2		35-63	47-85	132	
OM 314	900, 910, 914 - 915, 917 - 920, 940 - 951, 954, 959, 961 - 965, 967	D (NA)	4	97 x 128		2		35-66	48-90	131	
OM 314	916, 953	D (NA)	4	97 x 128	3780	2	17:1	40-59	54-80	136	
OM 314	956 - 957	D (NA)	4	97 x 128	3782	2	17:1	48-55	65-75	147	
OM 314	921 - 922	D (NA)	4	97 x 128	3782	2	17:1	48-57	65-78	133	
OM 314	970	D (A)	4	97 x 128	3782	2	16:1	63	85	167	
OM 327	930	D	6	115 x 128	7980	2				321	
OM 327	910, 914 - 919, 931 - 946	D (NA)	6	115 x 128	7980	2	17:1	110-125	150-170	321	
OM 335	910, 930	D (NA)	6	128 x 150	11581	4	17,2:1	154-176	209-239	368	
OM 335	932	D (NA)	6	128 x 150	11581	2	17,2:1	176	239	368	
OM 340	930, 932	D (NA)	4	97 x 128	3780	2	17:1	62-63	84-86	174	
OM 340	919-001	D	4	97 x 128	3780	2	17:1	63	86	132	
OM 340	919	D	4	97 x 128	3780	2	17:1	63	86	173	
OM 341	934	D (NA)	6	97 x 128	5675	2	17:1	62	84	142	
OM 341	918	D (NA)	6	97 x 128	5675	2	17:1	66	90	138	
OM 341	910 - 912, 915, 919, 931 - 932, 935 - 936, 938, 941, 946, 949, 995	D (NA)	6	97 x 128	5675	2	17:1	66-96	90-131	137	
OM 341	900-001	D	6	97 x 128	5675	2	17:1	74	100	132	
OM 341	900	D (NA)	6	97 x 128	5675	2	17:1	74	101	173	
OM 341	947	D (NA)	6	97 x 128	5675	2	17:1	96	131	143	
OM 341	948, 951	D (NA)	6	97 x 128	5675	2	17:1	96	131	175	
OM 341	933, 950	D (A)	6	97 x 128	5675	2	17:1	96	131	149	
OM 341	937, 939, 943	D (A)	6	97 x 128	5675	2	17:1	96-115	131-156	143	
OM 341	913, 996	D (A)	6	97 x 128	5675	2	17:1	115-118	156-160	142	
OM 343	919-001	D	4	97 x 128	3780	2	17:1	39	53	132	
OM 343	919	D	4	97 x 128	3780	2	17:1	39	53	173	
OM 343	919-018	D	4	97 x 128	3780	2	17:1	53	72	176	
OM 343	910, 932	D (NA)	4	97 x 128	3780	2	17:1	62-63	84-86	174	
OM 343	934	D (NA)	4	97 x 128	3780	2	17:1	63	86	177	
OM 344	919	D	6	97 x 128	5675	2				173	
OM 344	919-063	D	6	97 x 128	5675	2	17:1	84	114	152	
OM 344	919-001	D	6	97 x 128	5675	2	17:1	88	120	132	
OM 344	964 (USA)	D	6	97 x 128	5675	2	17:1	94	126	157	

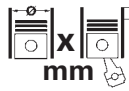

## MERCEDES-BENZ

				Cyl.	 mm	cm <sup>3</sup>		Comp. Ratio ε	kW	PS	Pos
OM 344	949	D (A)	6	6	97 x 128	5675	2	16:1	96	131	169
OM 344	991, 997	D	6	6	97 x 128	5675	2	17:1	96	130	134
OM 344	940 - 941	D (A)	6	6	97 x 128	5675	2	17:1	96	131	134
OM 344	930, 932	D (NA)	6	6	97 x 128	5675	2	17:1	96	131	178
OM 344	905, 912, 946, 963	D (NA)	6	6	97 x 128	5675	2	17:1	96	131	134
OM 344	933, 944	D (NA)	6	6	97 x 128	5675	2	17:1	96	131	137
OM 344	943, 945	D (NA)	6	6	97 x 128	5675	2	17:1	96	131	159
OM 344	920	D	6	6	97 x 128	5675	2	17:1	103	140	163
OM 344	942 (USA)	D (A)	6	6	97 x 128	5675	2	16:1	115	156	145
OM 344	913, 934, 937 - 939, 951, 953 - 955	D (A)	6	6	97 x 128	5675	2		115-124	156-168	144
OM 344	931, 948, 952	D (A)	6	6	97 x 128	5675	2	16:1	115-124	156-169	140
OM 344	950 (USA)	D (A)	6	6	97 x 128	5675	2	16:1	125	168	146
OM 345	914-001 (BRA), 914-002 (BRA), 914-003 (BRA), 914-004 (BRA), 914-005 (BRA)	D	6	6	128 x 150	11581	2	17,2:1	103-135	140-185	473
OM 345	919 (BRA)	D	5	5	128 x 150	9651	2	17,2:1	114	155	363
OM 345	900, 915, 941, 945 - 947	D (NA)	5	5	128 x 150	9651	4	17,2:1	125-141	170-192	363
OM 345	910, 912, 932 - 933, 936 - 937	D (NA)	6	6	128 x 150	11581	4	17,2:1	137-177	186-241	376
OM 345	942	D (NA)	5	5	128 x 150	9651	4	17,2:1	141	192	364
OM 345	949, 972 - 973, 975	D (NA)	5	5	128 x 150	9651	4	17,2:1	143-150	194-204	368
OM 345	970 (BRA), 974 (BR), 977 - 978 (BRA)	D (A)	5	5	128 x 150	9651	2	16,5:1	147-170	200-230	368
OM 345	913, 960	D (A)	6	6	128 x 150	11581	4	16,5:1	210	286	377
OM 345	950 (BRA), 952 - 953 (BRA)	D (LA)	6	6	128 x 150	11581	2	16,5:1	235-250	320-340	368
OM 346	951	D (A)	6	6	128 x 140	10809	4				360
OM 346	910, 912 - 917, 919, 940 - 945, 947, 952 - 953	D (NA)	6	6	128 x 140	10809	2		132-155	180-210	361
OM 346	911, 918, 946	D (NA)	6	6	128 x 140	10809	4	17,5:1	132-155	180-210	361
OM 347	915, 942 - 943	D (NA)	5	5	128 x 150	9651	2	17,2:1	141-147	192-200	396
OM 347	917, 970 - 971	D (A)	5	5	128 x 150	9651	4		170-175	230-238	368
OM 352	956 - 958, 960 - 962	D	6	6	97 x 128	5675	2				129
OM 352	900	D	6	6	97 x 128	5675	2				151
OM 352	919	D (NA)	6	6	97 x 128	5675	2	17:1	48	65	136
OM 352	902 - 903, 906, 908, 936, 938, 963, 969, 980 - 982, 984, 989 - 990, 993, 997 - 998	D (NA)	6	6	97 x 128	5675	2		52-96	70-131	130
OM 352	900-000, 900-001, 900-002, 900-003, 900-004, 900-005, 900-007, 900-009, 900-011, 900-012, 900-014, 900-016, 900-017, 900-018, 900-019, 900-020, 900-021	D	6	6	97 x 128	5675	2		66-96	90-130	135
OM 352	901, 904 - 905, 907, 909 - 912, 914 - 915, 917, 930 - 935, 939, 942 - 945, 948, 953 - 955, 959, 964 - 967, 970 - 976, 978 - 979, 983, 985 - 987, 991 - 992, 996, 999	D (NA)	6	6	97 x 128	5675	2		69-97	94-132	129
OM 352	988	D (A)	6	6	97 x 128	5675	2	16:1	96	130	150
OM 352	900-006, 900-008, 900-010, 900-013, 900-015, 900-400, 900-410, 900-411, 900-412, 900-413, 900-414, 900-415, 900-416, 900-417, 900-418, 900-419, 900-420, 900-421, 900-422, 900-423, 900-424, 900-425, 900-426, 900-427, 900-428, 900-429, 900-430	D (A)	6	6	97 x 128	5675	2		99-124	135-168	135
OM 352	913, 916, 918, 937, 946, 949 - 950, 968, 994	D (A)	6	6	97 x 128	5675	2	16:1	110-115	150-156	133
OM 353	922 - 923, 930 - 936, 938	D (NA)	6	6	97 x 128	5675	2	17:1	62-88	84-120	179
OM 353	900 - 902, 904 - 905, 940 - 946, 960 - 966, 968 - 969, 980	D (NA)	6	6	97 x 128	5675	2		62-96	84-130	130
OM 353	985, 989	D (NA)	6	6	97 x 128	5675	2	17:1	70-96	95-130	153
OM 353	967	D (NA)	6	6	97 x 128	5675	2	17:1	74	101	180
OM 353	903, 915 - 917	D (NA)	6	6	97 x 128	5675	2	17:1	81-96	110-130	129
OM 353	949, 981 - 984	D (NA)	6	6	97 x 128	5675	2	17:1	81-96	110-130	139
OM 353	907	D (NA)	6	6	97 x 128	5675	2	17:1	92	125	161
OM 353	973	D (A)	6	6	97 x 128	5675	2	16,5:1	92	125	130
OM 353	995	D (A)	6	6	97 x 128	5675	2	16,5:1	92	125	168
OM 353	957	D (A)	6	6	97 x 128	5675	2	17:1	92	125	160
OM 353	937	D (A)	6	6	97 x 128	5675	2	16:1	92	125	179
OM 353	958	D (A)	6	6	97 x 128	5675	2	16,5:1	110	150	158
OM 353	976	D (A)	6	6	97 x 128	5675	2	16,5:1	110	150	166
OM 353	920 - 921, 939	D (A)	6	6	97 x 128	5675	2	16:1	110-124	150-169	164
OM 353	954	D (A)	6	6	97 x 128	5675	2	16,5:1	124	168	155
OM 353	959	D (A)	6	6	97 x 128	5675	2	16,5:1	124	168	162
OM 353	909 - 910	D (A)	6	6	97 x 128	5675	2	16,5:1	124-125	168-170	133

M

				Cyl.		mm	cm <sup>3</sup>	Comp. Ratio	€	kW	PS	Pos
OM 353	974 - 975	D (A)	6	6	97 x 128	5675	2			124-127	168-172	156
OM 353	911 - 914, 950 - 953, 970 - 972, 977 - 978, 991, 997	D (A)	6	6	97 x 128	5675	2			124-127	168-172	141
OM 354 Euro 2	900 - 903, 920, 923 - 926	D (LA)	4	4	97,5 x 133	3972	2			77-103	105-140	212
OM 354 Euro 2	921 - 922	D (LA)	4	4	97,5 x 133	3972	2	18:1		103	140	213
OM 355	960 - 964, 966 - 967, 970, 972 - 976, 979 - 982	D (NA)	6	6	128 x 150	11581	4			136-191	185-260	359
OM 355	916	D (NA)	6	6	128 x 150	11581	2	17,2:1		169	230	361
OM 355	910 - 915, 918	D (NA)	6	6	128 x 150	11581	4	17,2:1		169	230	365
OM 355	975-005 (AFS), 975-006 (AFS)	D	6	6	128 x 150	11581	4	17,2:1		176	240	408
OM 355	978	D (NA)	6	6	128 x 150	11581	4	17,2:1		177	240	474
OM 355	983 - 984	D (NA)	6	6	128 x 150	11581	4	17,2:1		177	240	367
OM 355	976-001 (AFS), 976-002 (AFS), 976-003 (AFS), 976-004 (AFS), 976-007 (AFS)	D	6	6	128 x 150	11581	4	17,2:1		177	240	376
OM 355	968	D (NA)	6	6	128 x 150	11581	2	16,5:1		191	260	366
OM 355	969, 977	D (A)	6	6	128 x 150	11581	4	16,5:1		205-206	275-280	366
OM 356 Euro 1	901 - 916	D (NA)	6	6	97,5 x 133	5958	2			75-100	102-136	208
OM 356 Euro 1	940 - 941, 943, 945 - 959	D (A)	6	6	97,5 x 133	5958	2			92-129	125-175	190
OM 356 Euro 1	944	D (A)	6	6	97,5 x 133	5958	2	16,5:1		116	158	230
OM 356 Euro 1	977 - 981, 983, 986 - 987, 989 - 998	D (LA)	6	6	97,5 x 133	5958	2			127-177	170-240	190
OM 356 Euro 0	984 - 985	D (LA)	6	6	97,5 x 133	5958	2	16,5:1		150-155	204-211	190
OM 356 Euro 1	999	D (LA)	6	6	97,5 x 133	5958	2	16,5:1		177	240	197
OM 356 Euro 1	988	D (LA)	6	6	97,5 x 133	5958	2	16,5:1		177	241	192
OM 357 Euro 2	912 - 913, 924, 945 - 946	D (LA)	6	6	97,5 x 133	5958	2			100-177	136-241	197
OM 357 Euro 2	900 - 904, 906 - 910, 915 - 922, 925, 927, 929 - 933, 936 - 938, 940 - 944, 947 - 949, 961 - 963	D (LA)	6	6	97,5 x 133	5958	2			125-177	170-240	190
OM 357 Euro 2	926	D (LA)	6	6	97,5 x 133	5958	2	18:1		155	211	192
OM 360	912, 914 - 918, 931, 933 - 944, 946 - 952, 954 - 956, 959 - 976, 978 - 981	D (NA)	6	6	115 x 140		2	16,8:1		81-141	110-192	321
OM 360	930, 977	D	6	6	115 x 140	8725	2			125	170	321
OM 360	910 - 911	D (LA)	6	6	115 x 140	8720	2	16,8:1		125-141	170-192	321
OM 360	982 - 986	D (A)	6	6	115 x 140	8720	2	16,8:1		125-154	170-210	321
OM 362	900/500	D (LA)	6	6	97 x 128	5675	2					171
OM 362	906, 909 - 910	D (LA)	6	6	97 x 128	5675	2	17:1		141	192	170
OM 364	900/000	D	4	4	97,5 x 133	3972	2					203
OM 364 Euro 0	901/400	D (A)	4	4	97,5 x 133	3972	2					204
OM 364 Euro 0	900-040	D	4	4	97,5 x 133	3972	2	17,25:1		49	67	202
OM 364 Euro 0	908 - 909	D (NA)	4	4	97,5 x 133	3972	2	17,25:1		50	68	222
OM 364 Euro 1	916 - 917	D (NA)	4	4	97,5 x 133	3972	2	19:1		58-60	79-82	226
OM 364 Euro 1	918	D (NA)	4	4	97,5 x 133	3972	2	19:1		63	86	223
OM 364 Euro 1	919 - 921	D (NA)	4	4	97,5 x 133	3972	2	17,3		63	86	221
OM 364 Euro 0	906 - 907, 911 - 912	D (NA)	4	4	97,5 x 133	3972	2			63-66	86-90	209
OM 364	913	D (NA)	4	4	97,5 x 133	3972	2	17,3		66	90	209
OM 364 Euro 0	951	D (A)	4	4	97,5 x 133	3972	2	16,5:1		66	90	223
OM 364 Euro 1	955 - 956, 982, 985, 989	D (LA)	4	4	97,5 x 133	3972	2			75-103	102-140	213
OM 364 Euro 1	959	D (A)	4	4	97,5 x 133	3972	2	18:1		77	105	213
OM 364 Euro 1	957 - 958	D (A)	4	4	97,5 x 133	3972	2	16,5		77	105	212
OM 364 Euro 0	979	D (A)	4	4	97,5 x 133	3972	2	16,3-16,5		85	116	226
OM 364 Euro 0	950, 952, 954	D (A)	4	4	97,5 x 133	3972	2	16,5		85	115	210
OM 364 Euro 0	980	D (LA)	4	4	97,5 x 133	3972	2	16,5:1		100	136	224
OM 364 Euro 1	986 - 987	D (LA)	4	4	97,5 x 133	3972	2	18:1		100	136	212
OM 364 Euro 0	981, 984	D (LA)	4	4	97,5 x 133	3972	2	17:1		100	136	210
OM 364 Euro 1	983	D (LA)	4	4	97,5 x 133	3972	2	18:1		102	139	229
OM 366 Euro 0	900/000	D	6	6	97,5 x 133	5958	2					208
OM 366 Euro 1	901-404	D (A)	6	6	97,5 x 133	5958	2					205
OM 366 Euro 2	901-507	D (LA)	6	6	97,5 x 133	5958	2					205
OM 366 Euro 1	901-504	D (LA)	6	6	97,5 x 133	5958	2					205
OM 366 Euro 0	901/400	D (A)	6	6	97,5 x 133	5958	2					233
OM 366 Euro 0	906 - 910, 912 - 914, 917 - 919, 930 - 933, 935 - 937, 939 - 940	D (NA)	6	6	97,5 x 133	5958	2			74-102	100-139	208
OM 366 Euro 1	915, 938	D (NA)	6	6	97,5 x 133	5958	2			75-102	102-139	208
OM 366 Euro 0	947 - 949, 954 - 956, 958, 963, 977	D (A)	6	6	97,5 x 133	5958	2	16,5:1		92-132	125-180	190
OM 366 Euro 1	911	D (NA)	6	6	97,5 x 133	5958	2	19:1		96	131	185
OM 366 Euro 0	905	D (LA)	6	6	97,5 x 133	5958	2	17,25:1		100	136	208
OM 366 Euro 1	941 - 943	D (A)	6	6	97,5 x 133	5958	2	18:1		116-121	158-165	190
OM 366 Euro 0	944 - 946, 951 - 953, 957, 962, 965 - 971, 973 - 974, 976, 978 - 979	D (A)	6	6	97,5 x 133	5958	2	16,5:1		116-129	158-175	195
OM 366 Euro 0	960, 975	D (A)	6	6	97,5 x 133	5958	2	16,5:1		125-129	170-175	200

M



			Cyl.		mm	cm <sup>3</sup>		Comp. Ratio $\epsilon$	kW	PS	Pos
OM 366 Euro 0	901-501, 901-540, 901-541, 901/-500	D (LA)	6		97,5 x 133	5958	2		136-177	185-240	205
OM 366 Euro 0	980 - 981, 983 - 984, 988, 990, 992 - 996	D (LA)	6		97,5 x 133	5958	2		148-157	201-214	190
OM 366 Euro 1	997, 999	D (LA)	6		97,5 x 133	5958	2		148-170	201-231	190
OM 370 Euro 0	905	D (NA)	4		97,5 x 133	3972	2	17,25:1	66	90	188
OM 370 Euro 0	952	D (A)	4		97,5 x 133	3972	2	16,5:1	80	109	215
OM 370 Euro 0	950 - 951	D (A)	4		97,5 x 133	3972	2	16,5:1	85	116	214
OM 372 Euro 0	930	D (NA)	6		97,5 x 133	5958	2	17,25:1	100	136	198
OM 372 Euro 0	906 - 907	D (NA)	6		97,5 x 133	5958	2	17,25:1	100	136	185
OM 372 Euro 0	950 - 951, 953, 956, 959, 961 - 962	D (A)	6		97,5 x 133	5958	2		100-135	136-184	190
OM 372 Euro 0	958, 960, 964	D (A)	6		97,5 x 133	5958	2	16,5:1	125	170	193
OM 372 Euro 0	980 - 982	D (LA)	6		97,5 x 133	5958	2	16,5:1	150	204	190
OM 372 Euro 0	983 - 985, 987	D (LA)	6		97,5 x 133	5958	2	16,5:1	150-155	204-211	193
OM 372 Euro 0	986	D (LA)	6		97,5 x 133	5958	2	16,5:1	155	211	194
OM 374 Euro 1	901-000	D (A)	4		97,5 x 133	3972	2				234
OM 374 Euro 0	900, 905, 908	D (NA)	4		97,5 x 133	3972	2		42-66	57-90	188
OM 374 Euro 0	907	D	4		97,5 x 133	3972	2	17,25:1	66	90	188
OM 374 Euro 0	986, 988	D (A)	4		97,5 x 133	3972	2	16,5:1	77-81	105-110	215
OM 374	992	D (NA)	4		97,5 x 133	3972	2	16,5:1	80	109	189
OM 374 Euro 0	953	D	4		97,5 x 133	3972	2	16,5:1	80	110	207
OM 374 Euro 0	950 - 952	D	4		97,5 x 133	3972	2	16,5:1	85	115	214
OM 374 Euro 0	976 - 979	D	4		97,5 x 133	3972	2	16,5:1	85-100	115-136	189
OM 374 Euro 0	980, 984 - 985	D (A)	4		97,5 x 133	3972	2	16,5:1	100-104	136-140	207
OM 374 Euro 0	987	D (A)	4		97,5 x 133	3972	2	16,5:1	104	140	194
OM 374 Euro 0	981 - 982	D (A)	4		97,5 x 133	3972	2	16,5:1	104	140	191
OM 374 989		D (LA)	4		97,5 x 133	3972	2	16,5:1	85	115	231
OM 374 990		D (LA)	4		97,5 x 133	3972	2	16,5:1	85	115	231
OM 374 991		D (LA)	4		97,5 x 133	3972	2	16,5:1	81	110	189
OM 374 993		D (LA)	4		97,5 x 133	3972	2	16,5:1	81	110	189
OM 374 994		D (LA)	4		97,5 x 133	3972	2	16,5:1	81	110	189
OM 374 996		D (LA)	4		97,5 x 133	3972	2	16,5:1	85	115	189
OM 374 997		D (LA)	4		97,5 x 133	3972	2	16,5:1	68	93	189
OM 376 Euro 0	911	D (A)	6		97,5 x 133	5958	2	16,5:1	66-172	90-234	191
OM 376 Euro 0	910	D (NA)	6		97,5 x 133	5958	2	17,25:1	69-100	94-136	198
OM 376 Euro 0	905 - 909, 930	D (NA)	6		97,5 x 133	5958	2	17,25:1	95-100	129-136	185
OM 376 Euro 0	945 - 947, 950 - 958, 961 - 962, 964, 967	D (A)	6		97,5 x 133	5958	2	16,5:1	125-135	170-184	186
OM 376 Euro 0	963, 993	D (LA)	6		97,5 x 133	5958	2	16,5:1	125-150	170-204	235
OM 376 Euro 0	980 - 982, 987 - 989, 998 - 999	D (LA)	6		97,5 x 133	5958	2	16,5:1	127-142	173-193	219
OM 376 Euro 0	968 - 970, 972, 975 - 977, 995, 997	D (LA)	6		97,5 x 133	5958	2	16,5:1	127-156	173-212	191
OM 376 Euro 0	911-511, 911-512, 911-513, 911-514	D (LA)	6		97,5 x 133	5958	2	16,5:1	127-172	170-230	189
OM 376 Euro 0	911-505, 911-506, 911-507, 911-508	D (LA)	6		97,5 x 133	5958	2	16,5:1	127-172	170-230	225
OM 376 Euro 0	941	D (LA)	6		97,5 x 133	5958	2	17,25:1	150	204	193
OM 376 Euro 0	984, 986, 994	D (LA)	6		97,5 x 133	5958	2	16,5:1	150-155	204-211	220
OM 377 Euro 0	944	D (A)	6		97,5 x 133	5958	2	16,5:1	125	170	197
OM 377 Euro 0	940 - 943, 945	D (A)	6		97,5 x 133	5958	2	16,5:1	125	170	187
OM 377 Euro 0	960, 962 - 964, 967 - 969, 972 - 973, 980 - 985	D (LA)	6		97,5 x 133	5958	2	16,5:1	140-170	190-231	187
OM 377 Euro 0	961	D (LA)	6		97,5 x 133	5958	2	16,5:1	150-170	204-231	236
OM 377 Euro 0	986	D (LA)	6		97,5 x 133	5958	2	16,5:1	155	211	189
OM 380 Euro 0	943	D (A)	4		97,5 x 133	3972	2	16,5:1	79	107	212
OM 380 Euro 0	940, 942	D (A)	4		97,5 x 133	3972	2	16,5:1	85	116	216
OM 382 Euro 0	912, 916	D (NA)	6		97,5 x 133	5958	2		96-100	130-136	208
OM 382 Euro 0	917, 950	D (A)	6		97,5 x 133	5958	2		110-125	150-170	199
OM 382 Euro 0	913, 919, 971	D (A)	6		97,5 x 133	5958	2	16,5:1	125-150	170-204	218
OM 382 Euro 0	970	D (LA)	6		97,5 x 133	5958	2	16,5:1	177	241	218
OM 384 Euro 0	906	D (A)	4		97,5 x 133	3972	2	17,25:1	66-100	90-137	201
OM 384 Euro 1	908	D (A)	4		97,5 x 133	3972	2	16,5:1	79	107	212
OM 384 Euro 0	907	D (A)	4		97,5 x 133	3972	2	16,5:1	85	116	217
OM 386 Euro 0	906	D (A)	6		97,5 x 133	5958	2	16,5:1	100	136	208
OM 386 Euro 0	950 - 952	D (A)	6		97,5 x 133	5958	2	16,5:1	125	170	196
OM 386 Euro 0	980 - 981, 983	D (LA)	6		97,5 x 133	5958	2	16,5:1	150	204	196
OM 390 Euro 0	900-006 (AMS), 900-007, 900-405 (AMS), 900-407	D (A)	6		97,5 x 133	5958	2	16,5:1	100-127	136-173	189
OM 390 Euro 0	900-505 (AMS), 900-506, 900-508 (AMS), 900-510, 900-511, 900-512, 900-513, 900-515, 900-516, 900-517, 900-518, 900-519, 900-521, 900-522, 900-523, 900-537, 900-539, 900-547, 900-549, 900-550	D (LA)	6		97,5 x 133	5958	2	16,5:1	127-156	170-212	189
OM 394	900-005 (AFS), 900-006 (AFS), 900-007 (AFS), 900-009 (AFS)	D	4		97 x 128	3780	2	17:1	48-63	65-85	148

M

				<b>Cyl.</b>		<b>mm</b>	<b>cm<sup>3</sup></b>		<b>Comp. Ratio</b> <b>ε</b>	<b>kW</b>	<b>PS</b>	<b>Pos</b>
<b>OM 396</b>	900-005, 900-007, 900-008 (AFS), 900-009, 900-010, 900-011, 900-012, 900-013, 900-014, 900-015, 900-016 (AFS), 900-020 (AFS), 900-021, 900-024, 900-026	D	6		97 x 128	5675	2	17:1	70-92	95-125	<b>148</b>	
<b>OM 396</b>	900-022 (AFS)	D	6		97 x 128	5675	2	17:1	88	120	<b>154</b>	
<b>OM 396</b>	900-017	D	6		97 x 128	5675	2	17:1	88	120	<b>181</b>	
<b>OM 396</b>	900-405 (AFS), 900-407, 900-409, 900-410, 900-415	D	6		97 x 128	5675	2	17:1	110-124	150-168	<b>165</b>	
<b>OM 401</b>	900-400	D (A)	6		125 x 130	9572	2				<b>324</b>	
<b>OM 401 Euro 1</b>	901-504	D (LA)	6		125 x 130	9572	2				<b>324</b>	
<b>OM 401</b>	901/-000	D	6		125 x 142	10456	2				<b>344</b>	
<b>OM 401</b>	900, 900-001	D	6		125 x 130		2		129	175	<b>324</b>	
<b>OM 401</b>	901	D (LA)	6		125 x 130	9570	2	0	129-188	175-256	<b>343</b>	
<b>OM 401</b>	912	D (K)	6		125 x 130	9570	2	17,2:1	141	192	<b>330</b>	
<b>OM 401</b>	905 - 906, 909, 914 - 916, 918 - 919, 922 - 923, 925 - 928	D (NA)	6		125 x 130	9570	2	17,2:1	141	192	<b>325</b>	
<b>OM 401</b>	907 - 908, 913, 921	D	6		125 x 130	9570	2	17,2:1	141	192	<b>325</b>	
<b>OM 401</b>	924	D (NA)	6		125 x 142	10456	2	17,5:1	144	196	<b>325</b>	
<b>OM 401 Euro 1</b>	976	D (LA)	6		125 x 130	9570	2	16,75:1	180	245	<b>340</b>	
<b>OM 401 Euro 1</b>	970, 972 - 975, 977 - 981, 984 - 987, 989 - 991, 993 - 994	D (LA)	6		125 x 130	9570	2	16,75:1	180-230	245-313	<b>336</b>	
<b>OM 401</b>	917	D (A)	6		125 x 130	9570	2	17,2:1	188	256	<b>330</b>	
<b>OM 402 Euro 1</b>	901/-504	D (LA)	8		125 x 130	12760	2				<b>346</b>	
<b>OM 402</b>	901/-000	D	8		125 x 142	13941	2				<b>345</b>	
<b>OM 402</b>	900-001, 900-003, 900-004	D	8		125 x 130	12760	2	16,75:1	147-188	188-256	<b>326</b>	
<b>OM 402</b>	905, 907, 910 - 914, 916 - 917, 919, 921, 923 - 928	D (NA)	8		125 x 130		2	17,2:1	176-188	240-256	<b>327</b>	
<b>OM 402</b>	900-400, 900/-000	D (A)	8		125 x 130	12760	2		180	245	<b>326</b>	
<b>OM 402</b>	906	D (NA)	8		125 x 130	12760	2		188	256	<b>331</b>	
<b>OM 402 Euro 1</b>	988	D (LA)	8		125 x 130	12760	2	16,75:1	280	381	<b>337</b>	
<b>OM 402 Euro 1</b>	984, 995	D (A)	8		125 x 130		2	16,75:1	280	381	<b>338</b>	
<b>OM 402 Euro 1</b>	980 - 981	D (LA)	8		125 x 130	12760	2	16,75:1	280	381	<b>339</b>	
<b>OM 402 Euro 1</b>	970 - 975, 977 - 978, 982 - 983, 985 - 987, 989 - 990, 996	D (LA)	8		125 x 130		2	16,75:1	280-295	381-401	<b>338</b>	
<b>OM 403</b>	900/-000	D	10		125 x 130	15960	2	17,2:1			<b>328</b>	
<b>OM 403</b>	900-001, 900-002, 911/-000	D	10		125 x 130	15960	2		184	250	<b>324</b>	
<b>OM 403</b>	910-001, 910-002, 910-003, 910-004, 910-005, 910-006	D	10		125 x 130	15960	2	17,2:1	184-236	250-320	<b>347</b>	
<b>OM 403</b>	910	D (NA)	10		125 x 130	15950	2		184-236	250-321	<b>325</b>	
<b>OM 403</b>	905 - 906, 915 - 919, 930 - 935	D (NA)	10		125 x 130	15950	2	17,2:1	184-261	250-355	<b>330</b>	
<b>OM 404</b>	900/-000	D	12		125 x 130	19140	2				<b>329</b>	
<b>OM 404</b>	901/-000	D	12		125 x 142	20911	2				<b>329</b>	
<b>OM 404</b>	901-400	D (A)	12		125 x 142	20911	2				<b>329</b>	
<b>OM 404</b>	918	D	12		125 x 142	20911	2	17,2:1	236	320	<b>333</b>	
<b>OM 407</b>	900/-000	D	6		125 x 150	11040	2				<b>324</b>	
<b>OM 407</b>	901-400, 901-600	D (A)	6		125 x 155	11412	2				<b>324</b>	
<b>OM 407</b>	901-500	D (LA)	6		125 x 155	11412	2				<b>324</b>	
<b>OM 407</b>	901/-000	D	6		125 x 155	11412	2				<b>330</b>	
<b>OM 407</b>	908	D (LA)	6		125 x 150	11040	2	17:1	132	180	<b>330</b>	
<b>OM 407</b>	900-001, 900-002	D	6		125 x 150	11040	2	17:1	132-155	180-210	<b>335</b>	
<b>OM 407</b>	905, 907, 909 - 911	D (NA)	6		125 x 150	11040	2	17:1	132-155	180-211	<b>330</b>	
<b>OM 407</b>	913 - 920	D (NA)	6		125 x 155	11413	2	16,5:1	147-177	200-240	<b>330</b>	
<b>OM 407</b>	930 - 932	D (NA)	6		125 x 155	11413	2	16,5:1	162	220	<b>322</b>	
<b>OM 407</b>	952 - 953, 956	D (A)	6		125 x 155	11413	2	16,5:1	206	280	<b>348</b>	
<b>OM 407</b>	951, 955	D (A)	6		125 x 155	11413	2	16,5:1	206	280	<b>334</b>	
<b>OM 407</b>	954	D (LA)	6		125 x 155	11413	2	16,5:1	235	320	<b>348</b>	
<b>OM 409</b>	901-000	D	5		125 x 150	9204	2				<b>329</b>	
<b>OM 409</b>	906 - 908	D (NA)	5		125 x 150	9204	2	17:1	135	184	<b>349</b>	
<b>OM 421</b>	901-410	D (A)	6		128 x 142	10965	2				<b>379</b>	
<b>OM 421</b>	901-500, 901-510	D (LA)	6		128 x 142	10965	2				<b>379</b>	
<b>OM 421</b>	900/-000	D	6		128 x 142	10965	2				<b>369</b>	
<b>OM 421</b>	901/-400	D (A)	6		128 x 142	10965	2				<b>389</b>	
<b>OM 421</b>	907	D (NA)	6		128 x 142	10964	2	16,9:1	159	216	<b>384</b>	
<b>OM 421</b>	905	D (NA)	6		128 x 142	10964	2	16,9:1	159	216	<b>382</b>	
<b>OM 421</b>	906, 910	D (NA)	6		128 x 142	10964	2	16,9:1	159	216	<b>369</b>	
<b>OM 421</b>	908 - 909	D (NA)	6		128 x 142	10964	2	16,9:1	159	216	<b>373</b>	
<b>OM 421</b>	951	D (A)	6		128 x 142	10964	2	16,25:1	184	250	<b>397</b>	
<b>OM 422</b>	901-500	D (LA)	8		128 x 142	14618	2				<b>378</b>	
<b>OM 422</b>	900/-000	D	8		128 x 142	14618	2				<b>475</b>	

			Cyl.		mm	cm <sup>3</sup>		Comp. Ratio $\epsilon$	kW	PS	Pos
OM 422	905 - 923	D (NA)	8	128 x 142	14618	2	16,9:1	184-206	250-280	370	
OM 422	901-410	D (A)	8	128 x 142	14618	2	16,9:1	206	280	378	
OM 422	951 - 952, 954, 956 - 959, 963	D (A)	8	128 x 142	14618	2	16,25:1	243-276	330-375	381	
OM 422	901	D (A)	8	128 x 142	14618	2	16,25:1	243-276	330-375	476	
OM 422	953, 955	D (LA)	8	128 x 142	14618	2	16,25:1	276	375	381	
OM 423	900/-000	D	10	128 x 142	18273	2				369	
OM 423	901-400, 901-500	D (A)	10	128 x 142	18273	2				386	
OM 423	901	D (A)	10	128 x 142	18273	2	16,25:1	184-418	250-568	380	
OM 423	905, 909	D (NA)	10	128 x 142	18273	2	16,9:1	261	355	382	
OM 423	906 - 908	D (A)	10	128 x 142	18273	2	16,9:1	261	355	382	
OM 423	901-510	D (LA)	10	128 x 142	18273	2	16,25:1	346	470	386	
OM 423	950	D (LA)	10	128 x 142	18273	2	16,25:1	368	500	387	
OM 424	901-400	D (A)	12	128 x 142	21930	2				379	
OM 424	900	D (NA)	12	128 x 142	21927	2		309	420	369	
OM 424	901	D (LA)	12	128 x 142	21927	2	16,25:1	441	600	380	
OM 424	901-500, 901.510	D (LA)	12	128 x 142		2		441	600	379	
OM 427	902-500	D (LA)	6	128 x 155	11970	2				477	
OM 427	900/-000, 901/-200	D	6	128 x 155	11970	2				373	
OM 427	902/-400	D (LA)	6	128 x 155	11970	2				478	
OM 427	903/-600	D (A)	6	128 x 155	11970	2				478	
OM 427	905, 910 - 911	D (NA)	6	128 x 155	11967	2	16,6:1	150-177	204-240	382	
OM 427	950 - 952	D (A)	6	128 x 155	11967	2	16,25:1	206	280	399	
OM 429	951	D (LA)	5	128 x 155	9970	2	17,25:1	175	235	393	
OM 429	955	D (LA)	5	128 x 155	9970	2	17,25:1	186	250	395	
OM 429	953	D (A)	5	128 x 155	9970	2	17,25:1	186	250	394	
OM 440 Euro 1	945	D (A)	8	128 x 142	14618	2	18:1	250	340	371	
OM 440 Euro 1	940 - 942	D (A)	8	128 x 142	14618	2	18:1	250	340	412	
OM 440 Euro 1	948	D (A)	8	128 x 142	14618	2	18:1	269	366	433	
OM 440 Euro 1	980, 984 - 985, 987 - 988, 990 - 991	D (LA)	8	128 x 142	14618	2	16,75:1	280-320	381-435	424	
OM 440 Euro 1	986, 989	D (LA)	8	128 x 142	14618	2	16,75:1	280-320	381-435	432	
OM 440 Euro 1	970, 972 - 973, 978 - 979, 981 - 983	D (LA)	8	128 x 142	14618	2	16,75:1	320-370	435-503	412	
OM 440 Euro 1	971, 975 - 976	D (LA)	8	128 x 142	14618	2	16,75:1	370	503	413	
OM 440	909	D (NA)	8	130 x 142	15078	2	16,9:1	195	265	504	
OM 440 Euro 1	907	D (NA)	8	130 x 142	15078	2	18:1	195	265	503	
OM 440 Euro 1	910 - 911	D (NA)	8	130 x 142	15078	2	16,9:1	218	296	541	
OM 441	901-500, 901-504, 901-505	D (LA)	6	128 x 142	10965	2				425	
OM 441 Euro 2	901-507	D (LA)	6	128 x 142	10965	2				425	
OM 441	901-400	D (A)	6	128 x 142	10965	2				425	
OM 441	901-520	D (LA)	6	128 x 142	10965	2				419	
OM 441 Euro 0	950, 953	D (A)	6	128 x 142	10964	2	16,25:1	191-200	260-272	398	
OM 441 Euro 0	955	D (A)	6	128 x 142	10965	2	16,25:1	200	272	420	
OM 441 Euro 1	980, 994 - 995, 997, 999	D (LA)	6	128 x 142	10964	2	16,25:1	230-250	313-340	428	
OM 441 Euro 1	986 - 993, 996, 998	D (LA)	6	128 x 142	10964	2	16,25:1	230-250	313-340	418	
OM 441	951, 981 - 983	D (LA)	6	128 x 142	10964	2	16,25:1	243-250	330-340	404	
OM 441 Euro 0	960 - 962, 985	D (LA)	6	128 x 142	10964	2	16,25:1	243-250	330-340	404	
OM 441	901	D (LA)	6	128 x 142	10964	2	17,2:1	250	340	479	
OM 441	901-530	D (LA)	6	128 x 142	10965	2		250	340	426	
OM 441 Euro 1	900-004	D	6	130 x 142	11309	2				507	
OM 441	900/-000	D	6	130 x 142	11309	2				507	
OM 441	906 - 907, 917	D	6	130 x 142	11309	2	16,9:1	150-160	204-218	503	
OM 441	905, 909, 911 - 916, 918 - 921, 923 - 927	D (NA)	6	130 x 142	11309	2	16,9:1	150-165	204-224	503	
OM 441 Euro 1	922, 932 - 933	D (NA)	6	130 x 142	11309	2	18:1	151	205	503	
OM 441	908	D (K)	6	130 x 142	11309	2	16,9:1	160-165	218-224	503	
OM 442	901-502	D (LA)	8	128 x 142	14618	2				421	
OM 442 Euro 2	901-507	D (LA)	8	128 x 142	14618	2				480	
OM 442	901-501	D (LA)	8	128 x 142	14618	2				427	
OM 442	901/-400	D (LA)	8	128 x 142	14618	2				423	
OM 442	901-500, 901-520	D (LA)	8	128 x 142	14618	2				422	
OM 442 Euro 1	901-504, 901-505, 901-506	D (LA)	8	128 x 142	14618	2				427	
OM 442 Euro 1	901-404	D (A)	8	128 x 142	14618	2				427	
OM 442 Euro 2	901-508	D (LA)	8	128 x 142	14618	2				427	
OM 442 Euro 1	977 - 978	D (A)	8	128 x 142	14618	2	18:1	250	340	412	
OM 442 Euro 0	960 - 968, 971 - 972, 976	D (A)	8	128 x 142	14618	2	16,25:1	260-269	354-366	391	
OM 442 Euro 0	941 - 946, 950, 952, 954 - 955, 957 - 959	D (A)	8	128 x 142	14618	2	16,25:1	260-269	354-366	390	
OM 442 Euro 0	969-502 (USA), 969-503 (USA), 969-504 (USA)	D (LA)	8	128 x 142	14618	2	16,25:1	261-298	350-400	405	
OM 442 Euro 0	974	D (A)	8	128 x 142	14618	2	16,25:1	269	366	481	
OM 442 Euro 0	975	D (A)	8	128 x 142	14618	2	16,25:1	269	366	392	
OM 442 Euro 0	951, 953	D (LA)	8	128 x 142	14618	2	16,25:1	320-329	435-447	390	

M





			Cyl.		mm	cm <sup>3</sup>		Comp. Ratio $\epsilon$	kW	PS	Pos
OM 457 Euro 4	974, 977		D (LA) 6		128 x 155	11967	4	17,25:1	220-300	299-408	457
OM 457 Euro 4	950 - 954, 959, 964 - 967, 969		D (LA) 6		128 x 155	11967	4	17,25:1	220-315	299-428	449
OM 457 Euro 2/3	933 - 934, 940		D (LA) 6		128 x 155	11967	4	17,25:1	220-315	299-428	437
OM 457 Euro 2/3	958		D (LA) 6		128 x 155	11967	4	17,25:1	230-315	313-428	487
OM 457 Euro 3	914		D (LA) 6		128 x 155	11967	4	17,25:1	250	340	441
OM 457 Euro 3	975		D (LA) 6		128 x 155	11967	4	17,2	260	354	465
OM 457 Euro 5	908 - 909		D (LA) 6		128 x 155	11970	4	17,25:1	260	354	466
OM 457 Euro 2	936, 938 - 939		D (LA) 6		128 x 155	11967	4	17,25:1	260-300	354-408	437
OM 457 Euro 3	962		D (LA) 6		128 x 155	11967	4	17,25:1	260-315	354-428	455
OM 457 Euro 2	947, 960		D (LA) 6		128 x 155	11967	4	17,25:1	260-315	354-428	455
OM 457 Euro 3	981		D (LA) 6		128 x 155	11967	4	17,25:1	260-315	354-428	450
OM 457 Euro 3	956		D (LA) 6		128 x 155	11967	4	17,25:1	260-315	354-428	454
OM 457 Euro 2	980		D (LA) 6		128 x 155	11967	4	17,25:1	260-315	354-428	470
OM 457 Euro 3	918		D (LA) 6		128 x 155	11967	4	17,25:1	260-315	354-428	469
OM 457 Euro 2/3	917		D (LA) 6		128 x 155	11967	4	17,25:1	260-315	354-428	468
OM 457 Euro 3	955		D (LA) 6		128 x 155	11967	4	17,25:1	260-315	354-428	446
OM 457 Euro 3	948, 957		D (LA) 6		128 x 155	11967	4	17,25:1	260-315	354-428	448
OM 457 Euro 5	983, 985		D (LA) 6		128 x 155	11967	4		260-335	354-455	465
OM 457 Euro 3	976		D (LA) 6		128 x 155	11967	4	17,25:1	260-335	354-456	457
OM 457 Euro 3	961		D (LA) 6		128 x 155	11967	4	17,25:1	260-355	354-483	449
OM 457 Euro 3	929		D (LA) 6		128 x 155	11967	4	17,25:1	265	360	443
OM 457 Euro 3	926		D (LA) 6		128 x 155	11967	4	17,25:1	265	360	442
OM 457 Euro 3	932		D (LA) 6		128 x 155	11967	4	17,25:1	265	360	462
OM 457 Euro 4	984		D (LA) 6		128 x 155	11967	4	17,25:1	265	360	489
OM 457 Euro 3	924 - 925, 928, 931		D (LA) 6		128 x 155	11967	4	17,25:1	265-280	360-381	440
OM 457 Euro 3	915 - 916, 927		D (LA) 6		128 x 155	11967	4	17,25:1	265-295	360-401	461
OM 457 Euro 4	968		D (LA) 6		128 x 155	11967	4	17,25:1	265-315	360-428	456
OM 457 Euro 3	919 - 920, 923		D (LA) 6		128 x 155	11967	4	17,25:1	280-315	381-428	453
OM 457 Euro 4	982		D (LA) 6		128 x 155	11967	4	17,25:1	295-315	401-428	488
OM 457 Euro 4	970		D (LA) 6		128 x 155	11967	4	17,25:1	315	428	472
OM 457 Euro 3	922		D (LA) 6		128 x 155	11967	4	17,25:1	320-325	435-442	460
OM 458 Euro 2	910		D (LA) 6		128 x 155	11970	4				492
OM 458	990 - 991		D (LA) 6		128 x 155	11967	4	18:1	220-375	299-510	457
OM 458 Euro 3	960		D (LA) 6		128 x 155	11967	4	17,25:1	260	354	451
OM 458	992		D (LA) 6		128 x 155	11967	4	18	265-375	360-510	488
OM 458 Euro 3	970, 980		D (LA) 6		128 x 155	11967	4	17,25:1	295-335	401-456	452
OM 460 Euro 3	952		D (LA) 6		128 x 166	12816	4	18:1	261	350	466
OM 460 Euro 3	906, 917, 920		D (LA) 6		128 x 166	12816	4	18:1	261-336	355-457	493
OM 460 Euro 3	926 - 927, 932 - 938		D (LA) 6		128 x 166	12816	4		261-336	355-457	494
OM 460 Euro 3	939 - 949, 961		D (LA) 6		128 x 166	12816	4		261-336	355-457	495
OM 460 Euro 3	975 - 981		D (LA) 6		128 x 166	12816	4	18:1	261-338	355-460	498
OM 460 Euro 3	900 - 905, 907 - 916, 918 - 919, 921 - 923, 925, 929, 931, 970 - 971		D (LA) 6		128 x 166	12816	4	18:1	261-338	355-460	471
OM 460 Euro 3	953, 972, 988		D (LA) 6		128 x 166	12816	4	18:1	265-390	360-530	465
OM 460 Euro 3	960		D (LA) 6		128 x 166	12816	4	18:1	306	416	487
OM 460 Euro 3	950		D (LA) 6		128 x 166	12816	4	18:1	315-350	428-476	496
OM 460 Euro 3	951		D (LA) 6		128 x 166	12816	4	18:1	315-360	428-490	497
OM 460 Euro 3	982 - 983		D (LA) 6		128 x 166	12816	4	18:1	324-336	441-457	467
OM 460	984		D (A) 6		128 x 166	12816	4		335-375	455-510	465
OM 462 Euro 0	900-410 (AFS)		D (A) 8		128 x 142	14618	2	16,25	260	354	374
OM 462 Euro 0	900-411 (AFS), 900-414		D (A) 8		128 x 142	14618	2	16,25	269	366	407
OM 462 Euro 0	900-510 (AFS)		D (LA) 8		128 x 142	14618	2	16,25	320	435	374
OM 462 Euro 0	900-511 (AFS)		D (LA) 8		128 x 142	14618	2	16,25	329	447	407
OM 462	900-010, 900-011 (AFS), 900-012, 900-013 (AFS)		D	8	130 x 142	15080	2	16,9:1	195-203	265-276	508
OM 463	900-010		D	10	130 x 142	18848	2	16,9:1	260-271	354-368	505
OM 466	900-405		D (A) 6		128 x 155	11970	2	16,25	175	238	374
OM 466	900-005 (AFS), 900-505		D (A) 6		128 x 155	11970	2	16,25	175-265	238-360	388
OM 470 Euro 6	902		D (LA) 6		125 x 145	10677	4	17,0:1			342
OM 470	946		D (LA) 6		125 x 145	10677	4	17			342
OM 470	918		D (LA) 6		125 x 145	10677	4	17			350
OM 470 Euro 6	923		D (LA) 6		125 x 145	10677	4	17	240-335	326-456	352
OM 470 Euro 6	922		D (LA) 6		125 x 145	10677	4	17	240-335	326-456	351
OM 470 Euro 6	903 - 904, 906 - 908, 910, 913 - 915, 917, 921		D (LA) 6		125 x 145	10677	4		240-375	326-510	341
OM 470 LA Euro 6			D (LA) 6		125 x 145	10677	4	17,0:1	240-315	326-428	342
OM 471	945		D (LA) 6		132 x 156	12809	4	17,3			566
OM 471 Euro 6	905, 911, 913 - 914, 917, 920, 927, 932 - 935		D (LA) 6		132 x 156	12809	4	17,0:1	306-375	416-510	562
OM 471 Euro 6	937		D (LA) 6		132 x 156	12809	4	17,3	306-375	416-510	565

M



				<b>Cyl.</b>		<b>cm<sup>3</sup></b>		<b>Comp. Ratio</b> <b>ε</b>	<b>kW</b>	<b>PS</b>	<b>Pos</b>
OM 471 Euro 6	915	D (LA)	6	132 x 156	12809	4	17,0:1	310-375	422-510	<b>563</b>	
OM 471 Euro 6	902, 919	D (LA)	6	132 x 156	12809	4	17,0:1	310-375	422-510	<b>560</b>	
OM 471 Euro 6	901, 910	D (LA)	6	132 x 156	12809	4	17,0:1	310-375	422-510	<b>559</b>	
OM 471 Euro 6	900, 906, 909	D (LA)	6	132 x 156	12809	4	17,0:1	310-375	422-510	<b>556</b>	
OM 471 Euro 6	928, 940 - 942	D (LA)	6	132 x 156	12809	4		310-375	422-510	<b>564</b>	
OM 471 Euro 6	946, 951	D (LA)	6	132 x 156	12809	4	17,3	310-375	422-510	<b>566</b>	
OM 471 Euro 6	903	D (LA)	6	132 x 156	12809	4	17,0:1	310-375	422-510	<b>561</b>	
OM 471 Euro 6	926	D (LA)	6	132 x 156	12809	4	17	310-390	422-530	<b>558</b>	
OM 471 Euro 6	922, 944	D (LA)	6	132 x 156	12809	4		310-390	422-530	<b>557</b>	
OM 471 LA Euro 6		D (LA)	6	132 x 156	12809	4	17,0:1	310-375	421-510	<b>559</b>	
OM 472	905	D (LA)	6	139 x 163	14841	4	17,0:1			<b>571</b>	
OM 472	900 - 904, 906 - 909	D (LA)	6	139 x 163	14841	4	17,0:1	335-512	455-696	<b>570</b>	
OM 473 Euro 6	906	D (LA)	6	139 x 171	15569	4	17,0:1			<b>571</b>	
OM 473 Euro 6	909, 919	D (LA)	6	139 x 171	15569	4	17,0:1	380-460	517-626	<b>569</b>	
OM 473 Euro 6	900, 903, 905	D (LA)	6	139 x 171	15569	4	17,0:1	380-460	517-626	<b>567</b>	
OM 473 Euro 6	901 - 902, 908	D (LA)	6	139 x 171	15569	4	17,0:1	380-460	517-626	<b>570</b>	
OM 473 Euro 6	907, 914 - 915, 917	D (LA)	6	139 x 171	15569	4		380-460	517-626	<b>568</b>	
OM 475 Euro 1	994	D (LA)	5	128 x 155	9973	2	16,25:1	184	250	<b>401</b>	
OM 475	950 - 954	D (A)	5	128 x 155	9973	2	16,25:1	184	250	<b>401</b>	
OM 475 Euro 1	984 - 986, 989, 991, 997 - 998	D (LA)	5	128 x 155	9973	2	16,25:1	184-224	250-305	<b>417</b>	
OM 475	977	D (A)	5	128 x 155	9973	2	16,25:1	205	279	<b>445</b>	
OM 475	974, 976, 978	D (A)	5	128 x 155	9973	2	16,25:1	205-235	279-320	<b>417</b>	
OM 475	982	D (LA)	5	128 x 155	9973	2	16,25:1	221	300	<b>417</b>	
OM 475	907	D (LA)	5	128 x 155	9973	2	16,25:1	221	301	<b>401</b>	
OM 475	907-505, 907-506	D (LA)	5	128 x 155	9973	2	16,25:1	221	300	<b>499</b>	
OM 475	979	D (LA)	5	128 x 155	9973	2	16,25:1	235	320	<b>458</b>	
OM 476	916, 950	D (A)	6	128 x 155	11967	2	16,25-1 6,6	213-246	290-335	<b>401</b>	
OM 476	916-405, 916-406, 917-505, 917-506, 917-508	D (A)	6	128 x 155	11970	2		213-310	290-422	<b>499</b>	
OM 476 Euro 2	971 - 973, 977 - 980, 983	D (LA)	6	128 x 155	11967	2		257-264	350-359	<b>401</b>	
OM 476	917, 981 - 982, 988, 991 - 992	D (LA)	6	128 x 155	11967	2		257-310	350-422	<b>401</b>	
OM 476 Euro 1	985	D (LA)	6	128 x 155	11967	2	16,6:1	261	355	<b>417</b>	
OM 481	904	D (NA)	6	128 x 142	10964	2	16,9:1	159	216	<b>362</b>	
OM 481	902	D (NA)	6	128 x 142	10965	2	16,9:1	159	216	<b>385</b>	
OM 482	912	D (NA)	8	128 x 142	14618	2	16,9:1	206	280	<b>500</b>	
OM 482	930	D (NA)	8	128 x 142	14618	2	16,9:1	206	280	<b>501</b>	
OM 482	940 - 941	D (A)	8	128 x 142	14618	2	16,25:1	269	366	<b>434</b>	
OM 485	980	D (LA)	5	128 x 155	9973	2		221	301	<b>483</b>	
OM 489 Euro 1	960 - 961	D (LA)	5	128 x 155	9973	2		155-184	211-250	<b>417</b>	
OM 492	900-001 (AFS), 900-002 (AFS), 900-004 (AFS), 900-005, 900-007, 900-008, 900-009	D	8	128 x 142	14618	2	16,9:1	184-206	250-280	<b>375</b>	
OM 492	900-010, 900-013	D	8	128 x 142	14618	2	16,9:1	206	280	<b>502</b>	
OM 492	900-405 (AFS), 900-406 (AFS), 900-409 (AFS), 900-411 (AFS)	D (A)	8	128 x 142	14618	2	16,25:1	221-243	300-330	<b>383</b>	
OM 492	900-501 (AFS)	D (LA)	8	128 x 142	14618	2	16,25:1	276	375	<b>383</b>	
OM 493	900-001 (AFS), 900-501 (AFS)	D	10	128 x 142	18273	2	16,9:1	261-368	355-500	<b>383</b>	
OM 495	900-001 (AFS), 900-002 (AFS), 900-003 (AFS), 900-009 (AFS), 900-010 (AFS)	D	5	125 x 150	9204	2	17:1	135	183	<b>323</b>	
OM 496	900-001 (AFS), 900-002 (AFS), 900-003 (AFS), 900-023 (AFS), 900-026 (AFS), 900-027 (AFS), 900-030 (AFS), 900-031 (AFS), 900-034 (AFS), 900-035 (AFS), 900-201 (AFS)	D	6	125 x 155	11412	2	16,5:1	147-162	200-220	<b>323</b>	
OM 496	900-401 (AFS), 900-402 (AFS), 900-425 (AFS), 900-426 (AFS), 900-429 (AFS), 900-430 (AFS), 900-431 (AFS), 900-501 (AFS)	D	6	125 x 155	11412	2	16,5:1	202-235	275-320	<b>332</b>	
OM 521 Euro 2	950 - 951	D (LA)	6	130 x 150	11946	4	17,25:1	260-335	354-456	<b>513</b>	
OM 521 Euro 2	940	D (LA)	6	130 x 150	11946	4	17,25:1	315	428	<b>512</b>	
OM 521 Euro 2	952	D (LA)	6	130 x 150	11946	4	17,25:1	430	585	<b>542</b>	
OM 522 Euro 2	954	D (LA)	8	130 x 150	15928	4	17,25:1			<b>544</b>	
OM 522 Euro 2	940 - 943	D (LA)	8	130 x 150	15928	4	17,25:1	362-420	496-571	<b>520</b>	
OM 522 Euro 2	950	D (LA)	8	130 x 150	15928	4	17,25:1	530	721	<b>510</b>	
OM 522 Euro 2	951 - 953	D (LA)	8	130 x 150	15928	4	17,25:1	530-560	721-762	<b>543</b>	
OM 541 Euro 2/3	951	D (LA)	6	130 x 150	11946	4	17,25:1	230-235	313-320	<b>512</b>	
OM 541 Euro 2/3	940 - 941	D (LA)	6	130 x 150	11946	4		230-235	313-320	<b>514</b>	
OM 541 Euro 2/3	952	D (LA)	6	130 x 150	11946	4	17,25:1	230-260	313-354	<b>545</b>	
OM 541 Euro 2	922 - 927	D (LA)	6	130 x 150	11946	4	17,25:1	230-315	313-428	<b>514</b>	

				Cyl.		mm	cm <sup>3</sup>		Comp. Ratio $\epsilon$	kW	PS	Pos
OM 541 Euro 2	920 - 921	D (LA)	6	130 x 150	11946	4	17,25:1	230-315	313-428	523		
OM 541 Euro 4	970	D (LA)	6	130 x 150	11946	4	18,5:1	235	320	531		
OM 541 Euro 4/5	971	D (LA)	6	130 x 150	11946	4	17,75:1	235	320	532		
OM 541 Euro 5	996, 998	D (LA)	6	130 x 150	11946	4	17,75:1	235-265	320-360	530		
OM 541 Euro 4/5	955 - 957	D (LA)	6	130 x 150	11946	4		235-300	320-408	546		
OM 541 Euro 4/5	953, 991, 997, 999	D (LA)	6	130 x 150	11946	4		235-320	320-435	530		
OM 541 Euro 3	942 - 947, 950	D (LA)	6	130 x 150	11946	4	17,25:1	260-320	354-435	514		
OM 541 Euro 4	972 - 974, 976	D (LA)	6	130 x 150	11946	4	18,5:1	265-320	360-435	532		
OM 541 Euro 5	990	D (LA)	6	130 x 150	11946	4	17,75:1	300	408	536		
OM 541 Euro 4/5	959	D (LA)	6	130 x 150	11946	4	18,5:1	300	408	547		
OM 541 Euro 4	975, 977	D (LA)	6	130 x 150	11946	4	18,5:1	300-320	408-435	533		
OM 541 Euro 2	928	D (LA)	6	130 x 150	11946	4	17,25:1	315	428	515		
OM 541 Euro 4/5	993	D (LA)	6	130 x 150	11946	4	17,75:1	320	435	537		
OM 541 Euro 5	992, 994	D (LA)	6	130 x 150	11946	4	17,75:1	320-335	435-456	537		
OM 541 Euro 3	981	D (LA)	6	130 x 150	11946	4	18,5:1	335	456	535		
OM 541	995	D (LA)	6	130 x 150	11946	4	17,75:1	335	456	538		
OM 541 Euro 3	980	D (LA)	6	130 x 150	11946	4	18,5:1	335	456	534		
OM 541 Euro 3	948 - 949	D (LA)	6	130 x 150	11946	4	17,25:1	335-355	456-483	512		
OM 541 Euro 3	978	D (LA)	6	130 x 150	11946	4	18,5:1	350	476	532		
OM 541 Euro 4/5	979	D (LA)	6	130 x 150	11946	4	18,5:1	350	476	533		
OM 541 Euro 4/5	982	D (LA)	6	130 x 150	11946	4		355	483	548		
OM 542 Euro 4/5	973	D (LA)	8	130 x 150	15928	4	17,25:1			552		
OM 542 Euro 3	940 - 945, 948	D (LA)	8	130 x 150	15928	4		320-425	435-578	519		
OM 542 Euro 2	925 - 926	D (LA)	8	130 x 150	15928	4	17,25:1	350-390	476-530	525		
OM 542 Euro 2	920 - 921	D (LA)	8	130 x 150	15928	4	17,25:1	350-390	476-530	524		
OM 542 Euro 5	963, 966, 971	D (LA)	8	130 x 150	15928	4		350-448	476-609	528		
OM 542	976	D (LA)	8	130 x 150	15928	4	17,25:1	370-480	503-653	549		
OM 542 Euro 2/3	946	D (LA)	8	130 x 150	15928	4	17,25:1	370-480	503-653	549		
OM 542 Euro 5	960	D (LA)	8	130 x 150	15928	4	17,5:1	375	510	540		
OM 542 Euro 5	961 - 962, 964	D (LA)	8	130 x 150	15928	4	18,5:1	375-440	510-598	539		
OM 542 Euro 2/3	947	D (LA)	8	130 x 150	15928	4	17,25:1	390-420	530-571	511		
OM 542 Euro 5	972	D (LA)	8	130 x 150	15928	4	18,5:1	405-480	551-653	551		
OM 542 Euro 2	922	D (LA)	8	130 x 150	15928	4	17,25:1	420	571	526		
OM 542 Euro 2	924	D (LA)	8	130 x 150	15928	4	17,25:1	420	571	527		
OM 542 Euro 2	923	D (LA)	8	130 x 150	15928	4	17,25:1	420	571	519		
OM 542 Euro 4/5	965	D (LA)	8	130 x 150	15928	4	18,5:1	440	598	528		
OM 542 Euro 5	970	D (LA)	8	130 x 150	15928	4	18,5:1	448	609	550		
OM 542 Euro 3	956 - 958	D (LA)	8	130 x 150	15928	4	17,25:1	448-450	609-612	510		
OM 542 Euro 5	975	D (LA)	8	130 x 150	15928	4	18,5:1	450	612	553		
OM 542 Euro 5	968 - 969	D (LA)	8	130 x 150	15928	4	18,5	480	653	529		
OM 601	911 - 912	D (NA)	4	87 x 84	1997	2	22	53-55	72-75	60		
OM 601	921	D (NA)	4	87 x 92,4	2197	2	22	54	72	60		
OM 601	913	D (NA)	4	87 x 84	1997	2	22	55	75	64		
OM 601	940 - 943	D (NA)	4	89 x 92,4	2299	2	22	58-60	79-82	83		
OM 601 Euro 2	900	D (NA)	4	89 x 92,4	2300	2		62	85	83		
OM 601	970	D (LA)	4	89 x 92,4	2299	2	19,5	72	98	87		
OM 602	911 - 912, 930 - 931, 938 - 939, 990, 993	D (NA)	5	87 x 84	2497	2		62-93	84-126	61		
OM 602	961 - 962	D (A)	5	87 x 84	2497	2	22	90-93	122-126	61		
OM 602	900/-000	D	5	89 x 92,4	2874	2				82		
OM 602	940 - 942, 946 - 948, 991, 994	D (NA)	5	89 x 92,4	2874	2		65-72	88-98	82		
OM 602	983, 986	D (A)	5	89 x 92,4	2874	2		75-90	102-122	85		
OM 602 Euro 2	980 - 981, 984 - 985, 989	D (LA)	5	89 x 92,4	2874	2		75-90	102-122	85		
OM 602	982	D (LA)	5	89 x 92,4	2874	2	19,5	95	129	85		
OM 603	912 - 913, 931	D (NA)	6	87 x 84	2996	2	22	80-83	109-113	62		
OM 603	950	D (A)	6	87 x 84	2996	2	22:1	100-105	136-143	63		
OM 603	960 - 963	D (A)	6	87 x 84	2996	2		100-110	136-148	62		
OM 603	970 - 972	D (A)	6	89 x 92,4	3449	2		100-110	136-150	84		
OM 604	915, 917	D (NA)	4	87 x 84	1997	4	22	65-85	88-116	65		
OM 604	910, 912	D (NA)	4	89 x 86,6	2155	4	22	55-70	75-95	86		
OM 605	910 - 912	D (NA)	5	87 x 84	2497	4	22	83	113	65		
OM 605	960, 962	D (LA)	5	87 x 84	2497	4	22	110	150	65		
OM 606	910, 912	D (NA)	6	87 x 84	2996	4	22	100	136	65		
OM 606	961	D (LA)	6	87 x 84	2996	4	22	130	177	65		
OM 606	962, 964	D (A)	6	87 x 84	2996	4	22	130	177	65		
OM 607 Euro 5	951	D (A)	4	76 x 80,5	1461	2		55-81	75-110	6		
OM 608	915	D (A)	4	76 x 80,5	1461	2		59-85	80-116	7		
OM 611	980	D (A)	4	88 x 88,3	2148	4	18	60-90	82-122	69		
OM 611 Euro 3	981, 987	D (A)	4	88 x 88,3	2148	4	18	60-95	82-129	69		
OM 611	960	D (LA)	4	88 x 88,4	2151	4	19	75-92	102-125	68		

M

				<b>Cyl.</b>		<b>mm</b>	<b>cm<sup>3</sup></b>	<b>Comp. Ratio</b>	<b>ε</b>	<b>kW</b>	<b>PS</b>	<b>Pos</b>
OM 611	961 - 962	D (LA)	4	88 x 88,3	2148	4	18	75-105	102-143	<b>68</b>		
OM 611 Euro 3	983	D (A)	4	88 x 88,4	2151	4	18:1	80-95	109-129	<b>69</b>		
OM 611A (60 KW CDI)		D (A)	4	88 x 88,4	2148	4	19:1	60	82	<b>68</b>		
OM 611LA (75 KW CDI)		D (A)	4	88 x 88,4	2148	4	19:1	75	102	<b>68</b>		
OM 612 Euro 3	981	D (A)	5	88 x 88,3	2685	4	18	110-115	150-156	<b>71</b>		
OM 612 Euro 3	983	D (A)	5	88 x 88,3	2685	4	18:1	115	156	<b>70</b>		
OM 612	961 - 963, 965 - 967	D (LA)	5	88 x 88,3	2685	4		115-125	156-170	<b>70</b>		
OM 612	990	D (LA)	5	88 x 97	2950	4	16,5	170	231	<b>70</b>		
OM 613	960 - 961	D (LA)	6	88 x 88,3		4	18	145	197	<b>70</b>		
OM 615	962 (ESP)	D	4	87 x 83,6	1988	2				<b>59</b>		
OM 615	910 - 912, 914, 917 - 919, 930, 932, 936 - 939, 941	D (NA)	4	87 x 92,4	2197	2		33-49	45-67	<b>59</b>		
OM 615		D (NA)	4	87 x 92,4	2197	2	21	40-44	55-60	<b>59</b>		
OM 615	913, 915, 940, 942 - 944, 960 - 961, 963 - 970	D (NA)	4	87 x 83,6	1988	2		40-46	54-62	<b>59</b>		
OM 615	935	D	4	87 x 92,4	2197	2	21:1	44	60	<b>59</b>		
OM 616	912, 917 - 919, 936 - 940, 960, 963	D (NA)	4	90,9 x 92,4	2399	2		35-61	48-83	<b>102</b>		
OM 616	915, 930 - 931	D (NA)	4	90,9 x 92,4	2399	2	21:1	38-44	52-60	<b>103</b>		
OM 616		D (NA)	4	90,9 x 92,4	2399	2	21	41-55	56-75	<b>102</b>		
OM 616	962 (ESP)	D	4	91 x 92,4	2399	2				<b>106</b>		
OM 616	910 - 911, 913 - 914, 916, 932 - 934, 942 - 944, 961	D (NA)	4	91 x 92,4		2		38-53	52-72	<b>106</b>		
OM 617	910, 912 - 913, 919, 931 - 933	D (NA)	5	90,9 x 92,4	2998	2		48-65	65-88	<b>102</b>		
OM 617	950 - 952	D (A)	5	90,9 x 92,4	2998	2		85-92	116-125	<b>102</b>		
OM 621	912 - 913, 915 - 916, 918 - 919, 930 - 932	D (NA)	4	87 x 83,6	1988	2		25-40	34-55	<b>59</b>		
OM 622	951	D (A)	4	80 x 79,5	1598	4	15,4	65-84	88-114	<b>13</b>		
OM 626 Euro 6	951	D (LA)	4	80 x 79,5	1598	4	15,4	85-100	116-136	<b>13</b>		
OM 628	960 - 963	D (LA)	8	86 x 86	3996	4	18,5	184-191	250-260	<b>56</b>		
OM 629	910 - 912	D (LA)	8	86 x 86	3996	4		225-235	306-320	<b>56</b>		
OM 636	915	D (NA)	4	73,5 x 100	1697	2	19	29	39	<b>3</b>		
OM 636	900, 916 - 919, 932 - 941, 944, 946 - 947, 955 - 957, 959 - 960	D	4	75 x 100	1767	2		15-32	21-43	<b>5</b>		
OM 636	914, 930 - 931	D (NA)	4	75 x 100	1767	2		25-32	34-44	<b>5</b>		
OM 640	940, 942	D (A)	4	83 x 92	1991	4	18	60-80	82-109	<b>33</b>		
OM 640	941	D (LA)	4	83 x 92	1991	4	18	100-103	136-140	<b>33</b>		
OM 642	986	D (LA)	6	83 x 92	2987	4	16,5:1	135-140	184-190	<b>35</b>		
OM 642	820, 822, 826, 830, 832, 834 - 835, 870, 872, 884, 886, 890, 896, 898 - 899, 910, 920 - 921, 930, 932, 940, 950, 960 - 961, 970, 975, 990, 992 - 993	D (LA)	6	83 x 92	2987	4		135-200	184-272	<b>34</b>		
OM 642	836, 850, 856, 861 - 862, 868	D (A)	6	83 x 92	2987	4		150-190	204-258	<b>34</b>		
OM 642	838, 852 - 853, 858	D (A)	6	83 x 92	2987	4	15,5	170-195	231-265	<b>37</b>		
OM 642	854, 887	D (LA)	6	83 x 92	2987	4		180-195	245-265	<b>37</b>		
OM 642	867	D (A)	6	83 x 92	2987	4		185-190	252-258	<b>40</b>		
OM 642	855	D (A)	6	83 x 92	2987	4		190	258	<b>43</b>		
OM 642	873	D (LA)	6	83 x 92	2987	4		190	258	<b>44</b>		
OM 642	864	D (A)	6	83 x 92	2987	4	15,5	190	258	<b>35</b>		
OM 642	889	D (A)	6	83 x 92	2987	4		190	258	<b>46</b>		
OM 642	824	D (LA)	6	83 x 92	2987	4	18	190	258	<b>42</b>		
OM 646	983	D (LA)	4	88 x 88,3	2148	4	18,1	65-80	88-109	<b>74</b>		
OM 646	811 - 812, 820 - 821, 980 - 981, 984 - 985, 989 - 990, 992	D (LA)	4	88 x 88,3	2148	4		65-125	88-170	<b>72</b>		
OM 646	951	D (NA)	4	88 x 88,3	2148	4	18	75-90	102-122	<b>73</b>		
OM 646	961 - 963	D (LA)	4	88 x 88,3	2148	4	18	75-110	102-150	<b>73</b>		
OM 646	701	D (A)	4	88 x 88,3	2148	4		80-100	109-136	<b>72</b>		
OM 646 Euro 4	982	D (LA)	4	88 x 88,3	2148	4	18	80-110	109-150	<b>74</b>		
OM 646 Euro 4	986	D (LA)	4	88 x 88,3	2148	4	18	95-110	129-150	<b>72</b>		
OM 646	966	D (LA)	4	88 x 88,3	2148	4	18	100-110	136-150	<b>75</b>		
OM 647	961, 981	D (LA)	5	88 x 88,3	2685	4		60-130	82-177	<b>72</b>		
OM 648	960 - 961	D (LA)	6	88 x 88,3	3222	4		130-150	177-204	<b>72</b>		
OM 651	913, 956 - 957	D (LA)	4	83 x 99	2143	4	16,2	70-120	95-163	<b>36</b>		
OM 651 Filter	955	D (A)	4	83 x 99	2143	4	16,2	70-120	95-163	<b>36</b>		
OM 651	911 - 912, 916, 924 - 925, 940, 960 - 961, 980	D (A)	4	83 x 99	2143	4	16,2	70-152	95-207	<b>36</b>		
OM 651	901	D (LA)	4	83 x 83	1796	4	16,2	80-100	109-136	<b>38</b>		
OM 651	930	D (LA)	4	83 x 99	2143	4	16,2	80-130	109-177	<b>39</b>		
OM 651	958	D (LA)	4	83 x 99	2143	4	16,2	84-120	114-163	<b>45</b>		
OM 651	950	D (A)	4	83 x 99	2143	4	16,2	84-140	114-190	<b>41</b>		
OM 651	921	D (A)	4	83 x 99	2143	4		100-150	136-204	<b>39</b>		
OM 654	916	D (A)	4	78 x 83,6	1598	4		90-118	122-160	<b>8</b>		

				Cyl.		mm	cm <sup>3</sup>		Comp. Ratio $\epsilon$	kW	PS	Pos
OM 654	920	D (A)	4		82 x 92,3	1950	4			84-235	114-320	27
OM 656	929	D (LA)	6		82 x 92,3	2925	4	15,5		183-250	249-340	27
OM 661	911	D (NA)	4		89 x 92,4	2299	2	21		57-58	77-79	87
OM 662	911	D (NA)	5		89 x 92,4	2874	2	21		70	95	88
OM 668	914, 941	D (A)	4		80 x 84	1689	4	19,5		44-67	60-91	12
OM 668	940, 942	D (LA)	4		80 x 84	1689	4			55-70	75-95	12
OM 900 Euro 4	922	D (LA)	4		102 x 130	4249	3	17,4:1		95-115	129-156	242
OM 900 Euro 4	911 - 913, 915 - 921	D (LA)	4		102 x 130	4249	3			95-130	129-177	249
OM 900	910	D (LA)	4		102 x 130	4249	3	17,4:1		128	174	242
OM 902 Euro 3	970 - 972	D (LA)	6		102 x 130	6374	3			130-205	177-279	272
OM 902 Euro 4	922	D (LA)	6		102 x 130	6374	3			142	190	267
OM 902 Euro 4	910 - 912, 919 - 921	D (LA)	6		102 x 130	6374	3			157-194	213-264	238
OM 902 Euro 3	935	D (LA)	6		102 x 130	6374	3	18:1		170-205	231-279	268
OM 902 Euro 4	913 - 916, 923, 925	D (LA)	6		102 x 130	6374	3	17,4:1		175-210	238-286	251
OM 902 Euro 4	917 - 918, 924, 926 - 927, 930 - 934, 936	D (LA)	6		102 x 130	6374	3	17,4:1		175-210	238-286	252
OM 902 Euro 3	937	D (LA)	6		102 x 130	6374	3			180	245	269
OM 902 Euro 3	938	D (LA)	6		102 x 130	6374	3			191	260	270
OM 902 Euro 3	939	D (LA)	6		102 x 130	6374	3			191	260	271
OM 904 Euro 3	927 - 928, 936, 942, 947, 951 - 953, 955, 961, 964, 971, 975	D (LA)	4		102 x 130	4249	3			75-130	102-177	244
OM 904 Euro 2	904, 908 - 911, 914 - 917, 920, 923, 932, 939 - 940, 954, 956, 974, 980	D (LA)	4		102 x 130	4249	3			75-147	102-200	242
OM 904 Euro 2	903, 930, 941, 944, 946, 948 - 950, 959, 979	D (LA)	4		102 x 130	4249	3			90-130	122-177	244
OM 904 Euro 2	905 - 907, 912, 918 - 919, 921, 924 - 925, 935, 938, 943, 945	D (LA)	4		102 x 130	4249	3	17,4:1		90-134	122-182	240
OM 904 Euro 3	960	D (LA)	4		102 x 130	4250	3	18:1		100	136	262
OM 904 Euro 3	958, 969	D (LA)	4		102 x 130	4250	3	18:1		100-130	136-177	263
OM 904 Euro 3	965	D (LA)	4		102 x 130	4249	3	17,4:1		110	150	264
OM 904 Euro 3	957, 962, 966, 968, 970	D (LA)	4		102 x 130	4249	3	17,4:1		110-130	150-177	240
OM 904 Euro 2	977 - 978, 981	D (LA)	4		102 x 130	4249	3	17,4:1		110-130	150-177	273
OM 904 Euro 2	922	D (A)	4		102 x 130	4249	3	17,4:1		112	152	244
OM 904	985 - 986	D (LA)	4		102 x 130	4249	3	17,4		113-130	154-177	274
OM 904 Euro 2	926, 929, 931, 933 - 934, 937	D (LA)	4		102 x 130	4249	3	17,4:1		113-142	154-193	243
OM 904	987	D (LA)	4		102 x 130	4249	3	17,4		130	177	275
OM 904 Euro 3	967, 972 - 973, 976	D (LA)	4		102 x 130	4249	3	17,4:1		130	177	242
OM 906 Euro 3	987, 989	D (LA)	6		102 x 130	6374	3	18:1		100-170	136-231	263
OM 906 Euro 3	991	D (LA)	6		102 x 130	6374	3	18:1		130-205	177-279	253
OM 906 Euro 2	929, 944, 946, 948, 957 - 958, 978 - 981	D (LA)	6		102 x 130	6374	3			142-224	193-305	253
OM 906 Euro 2	913 - 914	D (LA)	6		102 x 130	6374	3	17,4:1		157-170	231	245
OM 906 Euro 2	917, 924, 932 - 933, 945, 947, 959, 966	D (LA)	6		102 x 130	6374	3			157-209	214-284	241
OM 906 Euro 2	931	D (A)	6		102 x 130	6374	3	17,4:1		170	231	255
OM 906 Euro 2/3	951	D (A)	6		102 x 130	6374	3	17,4-18		170	231	254
OM 906 Euro 2	910	D (A)	6		102 x 130	6374	3	17,4:1		170	231	253
OM 906 Euro 2	937	D (LA)	6		102 x 130	6374	3	17,4:1		170	231	247
OM 906 Euro 3	973	D (LA)	6		102 x 130	6374	4	17,4:1		170	231	265
OM 906 Euro 2/3	982	D (LA)	6		102 x 130	6374	3	17,4-18		170	231	258
OM 906 Euro 2/3	971	D (LA)	6		102 x 130	6374	3	17,4-18		170-180	231-245	241
OM 906 Euro 2/3	964 - 965	D (LA)	6		102 x 130	6374	3	17,4-18		170-205	231-279	254
OM 906 Euro 3	925 - 927, 960	D (LA)	6		102 x 130	6374	3			170-205	231-279	245
OM 906 Euro 3	928, 935, 939, 949 - 950, 952, 955, 961 - 962	D (LA)	6		102 x 130	6374	3	17,4-18		170-205	231-279	254
OM 906 Euro 2	915 - 916, 919 - 923, 940	D (A)	6		102 x 130	6374	3			170-205	231-279	245
OM 906 Euro 2	936	D (LA)	6		102 x 130	6374	3	17,4-18		172	234	276
OM 906 Euro 2/3	968	D (LA)	6		102 x 130	6374	3	17,4-18		172-187	230-254	253
OM 906 Euro 3	999	D (LA)	6		102 x 130	6374	3			172-194	234-264	239
OM 906 Euro 2	954, 956	D (LA)	6		102 x 130	6374	3	17,4:1		172-209	234-284	251
OM 906 Euro 2	975	D (LA)	6		102 x 130	6374	3	17,4:1		180	245	261
OM 906 Euro 3	963	D (LA)	6		102 x 130	6374	3	18:1		180	245	257
OM 906 Euro 3	983	D (LA)	6		102 x 130	6374	3	17,4-18		180	245	259
OM 906 Euro 2	918	D (A)	6		102 x 130	6374	3	17,4:1		180	245	241
OM 906 Euro 3	953, 985, 988	D (LA)	6		102 x 130	6374	3	17,4:1		180-205	245-279	241
OM 906 Euro 3	990, 992 - 995, 998	D (LA)	6		102 x 130	6374	3			180-206	245-279	266
OM 906 Euro 2	912	D (A)	6		102 x 130	6374	3	17,4:1		194	264	252
OM 906 Euro 2	911, 970	D (LA)	6		102 x 130	6374	3	17,4:1		194-209	194-284	252
OM 906 Euro 2	930	D (A)	6		102 x 130	6374	3	17,4:1		205	279	246
OM 906 Euro 2	941	D (A)	6		102 x 130	6374	3	17,4:1		205	279	247
OM 906 Euro 3	986	D (LA)	6		102 x 130	6374	3	17,4:1		205	279	265
OM 906 Euro 3	938	D (LA)	6		102 x 130	6374	3	17,4:1		205	279	252
OM 906 Euro 2	934	D (LA)	6		102 x 130	6374	3	17,4:1		209	284	246

M







			Cyl.		mm	cm <sup>3</sup>		Comp. Ratio	kW	PS	Pos
											€
OM 941 Euro 2	910, 929 - 930, 960	D (LA)	6		130 x 150	11946	4	17,25:1	230-300	313-408	517
OM 941 Euro 2/3	991	D (LA)	6		130 x 150	11946	4	17,25:1	260-315	354-428	530
OM 941 Euro 2	970, 980 - 981, 990	D (LA)	6		130 x 150	11946	4	17,25:1	260-315	354-428	518
OM 941 Euro 2	920 - 921, 940	D (LA)	6		130 x 150	11946	4	17,25:1	260-315	354-428	514
OM 941	992	D (LA)	6		130 x 150	11946	4	17,25	265-350	360-476	542
OM 942	992	D (LA)	8		130 x 150	15928	4		330-420	449-571	551
OM 942 Euro 2	925, 990	D (LA)	8		130 x 150	15928	4	17,25:1	330-448	544-609	519
OM 942 Euro 2	900, 910 - 912, 930, 960, 970, 980	D (LA)	8		130 x 150	15928	4	17,25:1	350-420	470-570	521
OM 942 Euro 2	967	D (LA)	8		130 x 150	15928	4	17,25:1	370-380	503-517	522
OM 942	993	D (LA)	8		130 x 150	15928	4		376-480	510-653	555
OM 942	991	D (LA)	8		130 x 150	15928	4		448-480	609-653	554

M

				Pos					Pos
					280 TE (123.093)	09.1977 → 11.1985	M 110.988	B	54
/8 (W114)					300 T D (123.190)	09.1977 → 02.1979	OM 617.912	D	102
230.6 (114.015)	01.1968 → 11.1976	M 180.954	B	20	300 T D (123.190)	03.1979 → 11.1985	OM 617.912	D	102
250	07.1968 → 08.1972	M 114.920	B	20	300 T Turbo-D (123.193)	10.1980 → 11.1985	OM 617.952	D	102
250 (114.010)	01.1968 → 08.1972	M 114.920	B	20	<b>124 Convertible (A124)</b>				
250 2.8 (114.011)	06.1972 → 11.1976	M 130.923	B	57	300 CE / 320 CE	10.1992 → 05.1993	M 104.992	B	91
280 (114.060)	06.1972 → 11.1976	M 110.921	B	53	(124.066)				
280 E (114.062)	06.1972 → 11.1976	M 110.981	B	53	300 CE-24 (124.061)	04.1992 → 06.1993	M 104.980	B	77
/8 (W115)					300 CE-24 (124.061)	04.1992 → 06.1993	M 104.980	B	77
200	01.1968 → 01.1977	M 115.923	B	58	<b>124 Coupe (C124)</b>				
200	01.1968 → 01.1977	M 115.926	B	58	200 CE (124.040)	07.1992 → 07.1993	M 111.940	B	89
200 (115.015)	01.1968 → 01.1977	M 115.923	B	58	200 CE (124.041)	03.1990 → 12.1992	M 102.963	B	79
200 (115.015)	01.1968 → 01.1977	M 115.926	B	58	200 CE (124.041)	03.1990 → 12.1992	M 102.963	B	79
200 D (115.115)	01.1968 → 01.1977	OM 615.913	D	59	220 CE (124.042)	10.1992 → 05.1993	M 111.960	B	92
220 (115.010)	01.1968 → 07.1973	M 115.920	B	58	230 CE (124.043)	03.1987 → 12.1992	M 102.982	B	119
220 (115.010)	01.1968 → 07.1973	M 115.924	B	58	230 CE (124.043)	03.1987 → 12.1992	M 102.982	B	119
220 D (115.110)	01.1968 → 01.1977	OM 615.912	D	59	230 CE Cat (124.043)	06.1989 → 12.1992	M 102.982	B	119
230.4 (115.017)	08.1973 → 12.1976	M 115.951	B	117	300 CE	03.1987 → 12.1989	M 103.983	B	76
240 D (115.117)	08.1973 → 12.1976	OM 616.916	D	106	300 CE (124.050)	03.1987 → 05.1993	M 103.983	B	76
240 D 3.0 (115.114)	08.1974 → 11.1976	OM 617.910	D	102	300 CE-24 (124.051)	09.1989 → 12.1992	M 104.980	B	77
/8 Coupe (W114)					300 CE-24 (124.051)	09.1989 → 12.1992	M 104.980	B	77
250 C (114.021)	04.1969 → 06.1972	M 114.920	B	20	320 CE (124.052)	10.1992 → 05.1993	M 104.992	B	91
250 C 2.8 (114.023)	06.1972 → 11.1976	M 130.923	B	57	<b>124 Saloon (W124)</b>				
250 CE (114.022)	04.1969 → 04.1972	M 114.980	B	20	200	01.1986 → 10.1992	M 102.922	B	79
280 C (114.073)	06.1972 → 02.1977	M 110.921	B	53	200 (124.020)	12.1985 → 05.1990	M 102.922	B	79
280 CE (114.072)	06.1972 → 01.1977	M 110.981	B	53	200 (124.020)	01.1986 → 05.1990	M 102.922	B	79
<b>123 Coupe (C123)</b>					200 D (124.120)	12.1984 → 08.1989	OM 601.912	D	60
230 C (123.043)	05.1977 → 04.1980	M 115.954	B	117	200 D (124.120)	08.1989 → 06.1993	OM 601.912	D	60
230 CE (123.243)	04.1980 → 12.1985	M 102.980	B	118	200 E	11.1992 → 05.1993	M 102.922	B	79
280 C	03.1977 → 12.1980	M 110.984	B	53	200 E (124.019)	10.1992 → 06.1993	M 111.940	B	89
280 C (123.050)	03.1977 → 03.1980	M 110.923	B	53	200 E (124.021)	09.1988 → 12.1989	M 102.963	B	79
280 CE	03.1977 → 11.1985	M 110.988	B	54	200 E (124.021)	09.1988 → 08.1993	M 102.963	B	79
280 CE	09.1977 → 08.1979	M 110.988	B	54	220 E (124.022)	10.1992 → 06.1993	M 111.960	B	92
300 C Turbo-D (123.153)	09.1981 → 07.1985	OM 617.952	D	102	230 E (124.023)	12.1984 → 03.1992	M 102.982	B	119
300 D (123.153)	03.1977 → 12.1981	OM 617.912	D	102	230 E (124.023)	01.1985 → 06.1993	M 102.982	B	119
<b>123 Saloon (W123)</b>					230 E Cat (124.023)	06.1989 → 06.1993	M 102.982	B	119
200	02.1976 → 08.1980	M 115.938	B	58	250 D (124.125)	04.1985 → 06.1993	OM 602.912	D	61
200	02.1976 → 08.1980	M 115.939	B	58	250 D (124.125)	01.1989 → 06.1993	OM 602.912	D	61
200	06.1980 → 11.1985	M 102.939	B	78	250 Turbo-D (124.128)	09.1988 → 06.1993	OM 602.962	D	61
200 (123.020)	02.1976 → 08.1980	M 115.938	B	58	260 E (124.026)	09.1985 → 12.1989	M 103.940	B	28
200 (123.020)	02.1976 → 08.1980	M 115.939	B	58	260 E (124.026)	09.1985 → 08.1992	M 103.940	B	28
200 (123.220)	06.1980 → 11.1985	M 102.920	B	78	260 E 4-matic (124.226)	09.1986 → 08.1992	M 103.943	B	28
200 D	03.1979 → 11.1985	OM 615.940	D	59	260 E 4-matic (124.226)	12.1986 → 12.1989	M 103.940	B	28
200 D (123.120)	07.1976 → 02.1979	OM 615.940	D	59	280 E (124.028)	10.1992 → 06.1993	M 104.942	B	91
220 D	01.1977 → 03.1979	OM 615.941	D	59	300 D	09.1989 → 06.1993	OM 602.962	D	61
220 D (123.126)	01.1976 → 02.1979	OM 615.941	D	59	300 D (124.130)	12.1984 → 08.1989	OM 603.912	D	62
230 (123.023)	02.1976 → 03.1981	M 115.954	B	117	300 D (124.130)	08.1989 → 06.1993	OM 603.912	D	62
230 E (123.223)	04.1980 → 12.1985	M 102.980	B	118	300 D (124.130)	06.1990 → 06.1993	OM 603.912	D	62
240 D (123.123)	02.1976 → 02.1979	OM 616.912	D	102	300 D 4-matic (124.330)	09.1986 → 08.1992	OM 603.913	D	62
240 D (123.123)	03.1979 → 11.1985	OM 616.912	D	102	300 D 4-matic (124.330)	08.1989 → 06.1993	OM 603.913	D	62
250 (123.026)	02.1976 → 10.1979	M 123.921	B	55	300 E	01.1985 → 12.1985	M 103.980	B	76
250 (123.026)	10.1979 → 07.1985	M 123.921	B	55	300 E	06.1985 → 12.1989	M 103.983	B	76
280 (123.030)	02.1976 → 08.1981	M 110.923	B	53	300 E (124.030)	08.1985 → 08.1992	M 103.983	B	76
280 E	08.1976 → 08.1981	M 110.988	B	54	300 E 4-matic	09.1986 → 12.1989	M 103.983	B	76
280 E (123.033)	02.1976 → 11.1985	M 110.984	B	53	300 E 4-matic (124.230)	09.1986 → 06.1993	M 103.985	B	76
280 E (123.033)	02.1976 → 11.1985	M 110.988	B	54	300 E-24 (124.031)	09.1988 → 08.1992	M 104.980	B	77
300 D (123.130)	02.1976 → 07.1980	OM 617.912	D	102	300 E-24 (124.031)	09.1988 → 08.1992	M 104.980	B	77
300 D (123.130)	03.1979 → 11.1985	OM 617.912	D	102	300 Turbo-D (124.133)	09.1986 → 09.1988	OM 603.960	D	62
300 Turbo-D (123.133)	08.1981 → 07.1985	OM 617.952	D	102	300 Turbo-D (124.133)	09.1986 → 09.1988	OM 603.963	D	62
<b>123 T-Model (S123)</b>					300 Turbo-D (124.133)	09.1988 → 06.1993	OM 603.960	D	62
200 T	11.1980 → 11.1985	M 102.920	B	78	300 Turbo-D 4-matic	09.1986 → 09.1988	OM 603.960	D	62
200 T (123.280)	11.1980 → 11.1985	M 102.939	B	78	(124.333)				
230 T (123.083)	09.1977 → 03.1980	M 115.954	B	117	300 Turbo-D 4-matic	09.1986 → 09.1988	OM 603.963	D	62
230 TE (123.283)	04.1980 → 11.1985	M 102.980	B	118	(124.333)				
240 T D	09.1977 → 02.1979	OM 616.912	D	102	300 Turbo-D 4-matic	01.1988 → 06.1993	OM 603.963	D	62
240 T D (123.183)	03.1979 → 11.1985	OM 616.912	D	102	(124.333)				
250 T (123.086)	05.1978 → 10.1979	M 123.921	B	55	320 E (124.032)	10.1992 → 06.1993	M 104.992	B	91
250 T (123.086)	05.1978 → 08.1982	M 123.921	B	55	400 E 4.2 (124.034)	10.1992 → 06.1993	M 119.975	B	110
					500 E (124.036)	01.1991 → 06.1993	M 119.974	B	125
					<b>124 T-Model (S124)</b>				

		Pos					Pos		
200 E	11.1992 → 05.1993	M 102.922	B	79	190 D (201.122)	09.1984 → 12.1985	OM 601.921	D	60
200 T (124.080)	09.1985 → 08.1989	M 102.922	B	79	2.0 (201.022)	10.1982 → 10.1984	M 102.921	B	80
200 T (124.080)	01.1986 → 05.1990	M 102.922	B	79	2.0 (201.023)	08.1983 → 05.1990	M 102.924	B	79
200 T D (124.180)	09.1985 → 08.1991	OM 601.912	D	60	2.0 (201.023)	01.1986 → 05.1990	M 102.924	B	79
200 T D (124.180)	09.1988 → 08.1991	OM 601.912	D	60	2.3	09.1987 → 09.1988	M 102.985	B	119
200 TE	09.1988 → 12.1989	M 102.962	B	79	2.3 E	10.1982 → 09.1988	M 102.985	B	119
200 TE (124.079)	05.1986 → 06.1993	M 111.940	B	89	2.6	10.1982 → 09.1988	M 103.942	B	28
200 TE (124.081)	09.1988 → 08.1992	M 102.963	B	79	D 2.0 (201.122)	08.1983 → 08.1989	OM 601.911	D	60
220 TE (124.082)	10.1992 → 05.1993	M 111.960	B	92	D 2.0 (201.122)	08.1989 → 08.1993	OM 601.911	D	60
230 TE (124.083)	09.1985 → 08.1992	M 102.982	B	119	D 2.5 (201.126)	04.1985 → 08.1993	OM 602.911	D	61
230 TE (124.083)	09.1985 → 08.1992	M 102.982	B	119	D 2.5 (201.126)	08.1989 → 08.1993	OM 602.911	D	61
230 TE Cat (124.083)	06.1989 → 08.1992	M 102.982	B	119	E 1.8 (201.018)	04.1990 → 08.1993	M 102.910	B	79
250 T D (124.185)	09.1985 → 06.1993	OM 602.912	D	61	E 2.0	10.1982 → 06.1993	M 102.961	B	78
250 T D (124.185)	01.1989 → 06.1993	OM 602.912	D	61	E 2.0	01.1985 → 08.1993	M 102.962	B	79
250 TD Turbo (124.188)	03.1988 → 07.1993	OM 602.962	D	61	E 2.0 (201.024)	10.1982 → 06.1993	M 102.961	B	78
260 TE FGST.	09.1985 → 12.1989	M 103.940	B	28	E 2.0 (201.024)	10.1982 → 06.1993	M 102.962	B	79
260 TE FGST.	09.1989 → 08.1992	M 103.940	B	28	E 2.0 (201.024)	02.1985 → 12.1986	M 102.961	B	78
280 TE (124.088)	10.1992 → 06.1993	M 104.942	B	91	E 2.0 (201.024)	02.1985 → 12.1986	M 102.962	B	79
300 T D (124.190)	09.1986 → 06.1993	OM 603.912	D	62	E 2.0 (201.024)	02.1985 → 12.1986	M 102.962	B	79
300 T D (124.190)	01.1989 → 06.1993	OM 603.912	D	62	E 2.3	09.1986 → 08.1991	M 102.985	B	119
300 T D (124.190)	01.1989 → 06.1993	OM 603.912	D	62	E 2.3 (201.028)	10.1986 → 08.1993	M 102.985	B	119
300 T Turbo-D	09.1986 → 01.1989	OM 603.960	D	62	E 2.3-16	09.1985 → 12.1987	M 102.983	B	120
300 T Turbo-D	09.1986 → 01.1989	OM 603.963	D	62	E 2.3-16	09.1985 → 08.1988	M 102.983	B	120
300 T Turbo-D (124.193)	01.1989 → 06.1993	OM 603.960	D	62	E 2.3-16 (201.034)	04.1984 → 01.1987	M 102.983	B	120
300 T Turbo-D 4-matic (124.393)	09.1986 → 01.1989	OM 603.963	D	62	E 2.5-16	09.1988 → 08.1993	M 102.990	B	121
300 T Turbo-D 4-matic (124.393)	01.1989 → 06.1993	OM 603.960	D	62	E 2.5-16 Evolution	03.1989 → 08.1993	M 102.991	B	121
300 TD T	06.1992 → 05.1993	OM 603.960	D	62	E 2.5-16 Evolution II	05.1990 → 08.1993	M 102.992	B	121
300 TE (124.090)	01.1986 → 12.1989	M 103.983	B	76	E 2.6	09.1986 → 12.1989	M 103.942	B	28
300 TE (124.090)	01.1986 → 08.1992	M 103.983	B	76	E 2.6 (201.029)	09.1986 → 08.1993	M 103.942	B	28
300 TE 4-matic (124.290)	09.1986 → 12.1989	M 103.983	B	76	Turbo-D 2.5 (201.128)	02.1988 → 08.1993	OM 602.961	D	61
300 TE 4-matic (124.290)	09.1986 → 06.1993	M 103.985	B	76	Turbo-D 2.5 (201.128)	02.1988 → 08.1993	OM 602.961	D	61
300 TE-24 (124.091)	09.1989 → 08.1992	M 104.980	B	77	230				
300 TE-24 (124.091)	09.1989 → 08.1992	M 104.980	B	77	(111)	08.1965 → 12.1967	M 180.940	B	9
320 TE (124.092)	10.1992 → 06.1993	M 104.992	B	91	E 2.8 (114)	10.1981 → 12.1984	M 110.991	B	53
170 (W170)					G (461)	03.1979 → 03.1982	M 115.974	B	117
170 S (136)	01.1949 → 1957	M 136.040	B	4	G (461)	04.1992 → 09.1995	M 102.958	B	119
170 S (136)	01.1949 → 1957	M 136.042	B	4	GE (461)	01.1984 → 08.1993	M 102.981	B	118
170 S (136)	01.1949 → 1957	M 136.043	B	4	GE (461)	04.1992 → 09.1995	M 102.979	B	119
170 S (136)	01.1949 → 1957	M 136.044	B	4	GE (461)	04.1992 → 09.1995	M 102.996	B	119
170 S (136)	01.1949 → 1957	M 136.047	B	4	GE (461)	04.1992 → 09.1995	M 102.997	B	119
170 S (136)	01.1949 → 1957	M 136.048	B	4	GE (463)	09.1989 → 07.1993	M 102.989	B	119
170 S (136)	01.1949 → 1957	M 136.049	B	4	240				
170 S (136)	01.1949 → 1957	M 136.051	B	4	D (USA) (115)	01.1974 → 09.1976	OM 616.916	D	106
170 S (136)	01.1949 → 1957	M 136.052	B	4	GD (461)	09.1978 →	OM 616.940	D	102
170 S (136)	01.1949 → 1957	M 136.053	B	4	250				
170 S (136)	01.1949 → 1957	M 136.054	B	4	C 2.8 (114)	10.1981 → 12.1984	M 110.991	B	53
170 S (136)	01.1949 → 1957	M 136.055	B	4	GD (461)	09.1987 → 08.1992	OM 602.930	D	61
170 S (136)	01.1949 → 1957	M 136.071	B	4	GD (461)	12.1988 → 08.1992	OM 602.938	D	61
170 S (136)	01.1949 → 1957	M 136.072	B	4	GD (461)	09.1989 → 07.1993	OM 602.939	D	61
170 S (136)	01.1949 → 1957	M 136.073	B	4	GD (463)	09.1989 → 07.1993	OM 602.931	D	61
170 S (136)	1959 → 1957	M 136.050	B	4	280				
170 Sb (136)	01.1953 → 1956	M 191.010	B	4	(107)	01.1968 → 12.1971	M 130.922	B	57
170 Sb (136)	01.1953 → 1957	M 191.018	B	4	(116)	09.1972 → 07.1976	M 110.983	B	53
170 Va (136)	01.1949 → 1957	M 136.060	B	4	(461)	11.1979 → 08.1989	M 110.994	B	54
170 Vb (136)	01.1949 → 1957	M 136.060	B	4	SE 4.5 (108)	12.1975 → 04.1980	M 117.984	B	107
170 Vb (136)	01.1949 → 1957	M 136.071	B	4	290				
170 Vb (136)	01.1949 → 1957	M 136.072	B	4	GD (461)	04.1992 → 09.1997	OM 602.942	D	82
170 Vb (136)	01.1949 → 1957	M 136.073	B	4	GD (461)	04.1992 → 09.1997	OM 602.946	D	82
D	06.1949 → 10.1956	OM 636.915	D	3	GD (461)	04.1992 → 09.1997	OM 602.947	D	82
S	07.1953 → 09.1955	M 136.922	B	4	GD Turbo (461)	04.1992 → 09.2001	OM 602.983	D	85
S-D	07.1953 → 02.1958	OM 636.931	D	5	300				
V	06.1946 → 05.1950	M 136.920	B	2	D (115)	08.1973 → 01.1977	OM 617.910	D	102
190					D (115)	08.1973 → 01.1977	OM 617.913	D	102
D 2.2 (USA) (201)	09.1983 → 07.1985	OM 601.921	D	60	D 2.5 Turbo (USA) (124)	09.1989 → 08.1992	OM 602.962	D	61
E 3.2 AMG	09.1988 → 08.1993	M 103.983	B	76	E 2.6 (124)	09.1989 → 10.1992	M 103.940	B	28
190 (W201)					E 3.2 (124)	09.1992 → 06.1993	M 104.992	B	91
					E 3.2 (124)	09.1992 → 06.1993	M 104.992 (AMG 3.6)	B	104
					GD (460)	12.1979 → 08.1990	OM 617.931	D	102

M

			Pos				Pos		
GD (461)	12.1979 → 08.1990	OM 617.933	D	102	A 160 CDI / d (176.011)	06.2013 → 05.2018	OM 607.951	D	6
GD (463)	02.1989 → 10.1994	OM 603.931	D	62	A 180 (176.042)	09.2012 → 05.2018	M 270.910	B	31
GE (463)	09.1989 → 10.1994	M 103.987	B	76	A 180 CDI (176.000)	06.2012 → 10.2014	OM 651.901	D	38
SD Turbo (USA) (116)	02.1978 → 08.1980	OM 617.950	D	102	A 180 CDI (176.007)	06.2013 → 10.2014	OM 651.930	D	39
SD Turbo (USA) (126)	08.1980 → 10.1985	OM 617.951	D	102	A 180 CDI / d (176.012)	06.2012 → 05.2018	OM 607.951	D	6
SD Turbo (USA) (126)	11.1985 → 12.1987	OM 603.961	D	62	A 200 (176.043)	06.2012 → 05.2018	M 270.910	B	31
SE 2.8 (124)	01.1993 → 06.1993	M 104.942	B	91	A 200 CDI (176.001)	06.2012 → 10.2014	OM 651.901	D	38
SE 2.8 (126)	01.1993 → 06.1993	M 104.942	B	91	A 200 CDI / d (176.008)	02.2014 → 05.2018	OM 651.930	D	39
SE 2.8 (140)	09.1992 → 05.1993	M 104.944	B	91	A 200 CDI / d 4-matic (176.002)	02.2014 → 05.2018	OM 651.930	D	39
SE 3.2 (140)	03.1991 → 05.1993	M 104.990	B	90	A 200 Flex (176.043)	06.2015 → 05.2018	M 270.910	B	31
SEL 4.5 (109)		M 117.981	B	107	A 220 4-matic (176.047)	05.2014 → 05.2018	M 270.920	BG	29
<b>350</b>					A 220 CDI (176.003)	09.2012 → 05.2018	OM 651.930	D	39
D Turbo (USA) (126)	03.1990 → 06.1991	OM 603.970	D	84	A 220 CDI (176.003)	01.2014 → 05.2018	OM 651.930	D	39
GD Turbo (463)	09.1991 → 07.1993	OM 603.972	D	84	A 220 CDI 4-matic (176.005)	02.2014 → 05.2018	OM 651.930	D	39
SL 2.8 (107)	06.1976 → 07.1985	M 110.986	B	53	A 220 d (176.003)	07.2015 → 05.2018	OM 651.930	D	39
SL 2.8 (107)	06.1976 → 08.1985	M 110.990	B	54	A 220 d 4-matic (176.005)	07.2015 → 05.2018	OM 651.930	D	39
SL 2.8 (107)	10.1981 → 12.1984	M 110.992	B	53	A 250 (176.044)	06.2012 → 05.2018	M 270.920	BG	29
<b>380</b>					A 250 (176.050)	07.2015 → 05.2018	M 270.920	BG	29
SE 2.8 (126)	10.1979 → 07.1985	M 110.989	B	54	A 250 4-matic (176.046)	06.2013 → 05.2018	M 270.920	BG	29
SE 2.8 (126)	10.1979 → 12.1985	M 110.987	B	54	A 250 4-matic (176.051)	07.2015 → 05.2018	M 270.920	BG	29
<b>450</b>					<b>A-CLASS (W177)</b>				
SL 2.8 (107)	06.1976 → 07.1985	M 110.986	B	53	A 160 d (177.002)	05.2019 →	OM 608.915	D	7
SL 2.8 (107)	06.1976 → 08.1985	M 110.990	B	54	A 180 d (177.003)	03.2018 →	OM 608.915	D	7
SL 2.8 (107)	10.1981 → 12.1984	M 110.992	B	53	A 180 d (177.010)	10.2020 →	OM 654.920	D	27
<b>500</b>					A 200 d (177.012)	11.2018 →	OM 654.920	D	27
GE (463)	01.1993 → 08.1993	M 117.965	B	123	A 200 d 4-matic (177.013)	10.2019 →	OM 654.920	D	27
SE 2.8 (126)	10.1979 → 07.1985	M 110.989	B	54	A 220 (177.044)	07.2018 →	M 260.920	B	32
SE 2.8 (126)	10.1979 → 12.1985	M 110.987	B	54	A 220 4-matic (177.045)	07.2018 → 10.2019	M 260.920	B	32
<b>560</b>					A 220 d (177.014)	11.2018 →	OM 654.920	D	27
SL (107)	10.1985 →	M 117.967	B	124	A 220 d 4-matic (177.015)	10.2019 →	OM 654.920	D	27
<b>A-CLASS (W168)</b>					A 250 (177.046)	03.2018 →	M 260.920	B	32
A 140 (168.031, 168.131)	09.1997 → 08.2004	M 166.940	B	10	A 250 4-matic (177.047)	07.2018 →	M 260.920	B	32
A 140 (168.031, 168.131)	01.2001 → 08.2004	M 166.960	B	11	AMG A 35 4-matic (177.051)	09.2018 →	M 260.920	B	32
A 160 (168.033, 168.133)	09.1997 → 08.2004	M 166.960	B	11	<b>A-CLASS Saloon (V177)</b>				
A 160 CDI (168.006)	02.2001 → 08.2004	OM 668.940	D	12	A 160 d (177.102)	10.2019 →	OM 608.915	D	7
A 160 CDI (168.007)	07.1998 → 02.2001	OM 668.941	D	12	A 180 d (177.103)	09.2018 →	OM 608.915	D	7
A 170 CDI (168.008)	09.1998 → 02.2001	OM 668.940	D	12	A 180 d (177.110)	10.2020 →	OM 654.920	D	27
A 170 CDI (168.009, 168.109)	02.2001 → 08.2004	OM 668.942	D	12	A 200 d (177.112)	08.2019 →	OM 654.920	D	27
A 190 (168.032, 168.132)	03.1999 → 08.2004	M 166.990	B	48	A 200 d 4-matic (177.113)	10.2019 →	OM 654.920	D	27
A 210 (168.035, 168.135)	12.2001 → 08.2004	M 166.995	B	48	A 220 (177.144)	01.2019 →	M 260.920	B	32
A 38 AMG Twin Engine (168.032)	04.1999 → 02.2001	M 166.990	B	48	A 220 4-matic (177.145)	09.2018 →	M 260.920	B	32
<b>A-CLASS (W169)</b>					A 220 d (177.114)	08.2019 →	OM 654.920	D	27
A 150 (169.031, 169.331)	09.2004 → 06.2012	M 266.920	B	30	A 220 d 4-matic (177.115)	10.2019 →	OM 654.920	D	27
A 160 (169.031, 169.331)	04.2009 → 06.2012	M 266.920	B	30	A 250 (177.146)	09.2018 →	M 260.920	B	32
A 160 CDI (169.006, 169.306)	09.2004 → 06.2012	OM 640.942	D	33	A 250 4-matic (177.147)	09.2018 →	M 260.920	B	32
A 170 (169.032, 169.332)	09.2004 → 06.2012	M 266.940	B	30	AMG A 35 4-matic (177.151)	03.2019 →	M 260.920	B	32
A 180 (169.032, 169.332)	04.2009 → 06.2012	M 266.940	B	30	<b>B-CLASS Sports Tourer (W245)</b>				
A 180 CDI (169.007, 169.307)	09.2004 → 06.2012	OM 640.940	D	33	B 150 (245.231)	03.2005 → 11.2011	M 266.920	B	30
A 200 (169.033, 169.333)	09.2004 → 06.2012	M 266.960	B	30	B 160 (245.231)	04.2009 → 11.2011	M 266.920	B	30
A 200 CDI (169.008, 169.308)	09.2004 → 06.2012	OM 640.941	D	33	B 170 (245.232)	03.2005 → 11.2011	M 266.940	B	30
A 200 CDI (169.308, 169.008)	09.2004 → 06.2012	OM 640.941	D	33	B 170 NGT (245.233)	04.2008 → 11.2011	M 266.960	B	30
A 200 TURBO (169.034, 169.334)	09.2005 → 06.2012	M 266.980	B	30	B 180 (245.232)	04.2009 → 11.2011	M 266.940	B	30
<b>A-CLASS (W176)</b>					B 180 CDI (245.207)	03.2005 → 11.2011	OM 640.940	D	33
A 160 (176.041)	07.2015 → 05.2018	M 270.910	B	31	B 180 NGT (245.233)	04.2008 → 11.2011	M 266.960	B	30
					B 200 (245.233)	03.2005 → 11.2011	M 266.960	B	30
					B 200 CDI (245.208)	03.2005 → 11.2011	OM 640.941	D	33
					B 200 CDI (245.208)	03.2005 → 11.2011	OM 640.941	D	33
					B 200 TURBO (245.234)	03.2005 → 11.2011	M 266.980	B	30
					<b>B-CLASS Sports Tourer (W246, W242)</b>				
					B 160 (246.241)	07.2015 → 12.2018	M 270.910	B	31
					B 160 CDI / d (246.211)	05.2013 → 12.2018	OM 607.951	D	6



			Pos				Pos		
B 180 (246.242)	11.2011 → 12.2018	M 270.910	B	31	3.5 (203.056)	01.2005 → 02.2007	M 272.960	B	111
B 180 CDI (246.200)	11.2011 → 08.2014	OM 651.901	D	38	C 180 (203.035)	10.2000 → 05.2002	M 111.951	B	97
B 180 CDI (246.207)	06.2013 → 08.2014	OM 651.930	D	39	C 180 Kompressor (203.046)	05.2002 → 02.2007	M 271.946	B	21
B 180 CDI / d (246.212)	02.2013 → 12.2018	OM 607.951	D	6					
B 200 (246.243)	11.2011 → 12.2018	M 270.910	B	31	C 200 CDI (203.004)	09.2000 → 06.2003	OM 611.962	D	68
B 200 CDI (246.201)	11.2011 → 08.2014	OM 651.901	D	38	C 200 CDI (203.004)	02.2001 → 06.2003	OM 611.962	D	68
B 200 CDI / d (246.208)	08.2014 → 12.2018	OM 651.930	D	39	C 200 CDI (203.007)	04.2003 → 02.2007	OM 646.962	D	73
B 200 CDI / d 4-matic (246.202)	08.2014 → 12.2018	OM 651.930	D	39	C 200 CDI (203.007)	04.2003 → 02.2007	OM 646.963	D	73
B 200 Flexfuel (246.243)	11.2011 → 12.2018	M 270.910	B	31	C 200 CGI Kompressor (203.043)	07.2003 → 02.2007	M 271.942	B	21
B 200 Natural Gas Drive / B 200 c (242.848)	11.2012 → 12.2017	M 270.920	BG	29	C 200 Kompressor (203.042)	05.2002 → 02.2007	M 271.940	B	21
B 220 (246.245)	08.2014 → 12.2018	M 270.920	BG	29	C 200 Kompressor (203.045)	05.2000 → 06.2002	M 111.955	B	96
B 220 4-matic (246.247)	05.2013 → 12.2018	M 270.920	BG	29					
B 220 CDI / d (246.203)	11.2011 → 12.2018	OM 651.930	D	39	C 220 CDI (203.006)	05.2000 → 02.2007	OM 611.962	D	68
B 220 CDI / d (246.203)	06.2013 → 12.2018	OM 651.930	D	39	C 220 CDI (203.006)	05.2000 → 02.2007	OM 611.962	D	68
B 220 CDI / d (246.203)	08.2014 → 12.2018	OM 651.930	D	39	C 220 CDI (203.006)	05.2000 → 02.2007	OM 646.963	D	73
B 220 CDI / d 4-matic (246.205)	08.2014 → 12.2018	OM 651.930	D	39	C 220 CDI (203.008)	02.2003 → 02.2007	OM 646.963	D	73
B 220 d 4-matic (246.205)	06.2018 → 12.2018	OM 651.930	D	39	C 230 (203.052)	01.2005 → 02.2007	M 272.920	B	67
B 250 (246.244)	05.2012 → 12.2018	M 270.920	BG	29	C 230 Kompressor (203.040)	02.2004 → 02.2007	M 271.948	B	21
B 250 4-matic (246.246)	08.2014 → 12.2018	M 270.920	BG	29	C 240 (203.061)	05.2000 → 02.2007	M 112.912	B	95
<b>B-CLASS Sports Tourer (W247)</b>					C 240 4-matic (203.081)	07.2002 → 02.2007	M 112.916	B	95
B 160 d (247.002)	05.2019 →	OM 608.915	D	7	C 270 CDI (203.016)	12.2000 → 02.2007	OM 612.962	D	70
B 180 d (247.003)	12.2018 →	OM 608.915	D	7	C 270 CDI (203.016)	12.2000 → 02.2007	OM 612.962	D	70
B 180 d (247.010)	10.2020 →	OM 654.920	D	27	C 280 (203.054)	01.2005 → 02.2007	M 272.940	B	67
B 200 d (247.012)	12.2018 →	OM 654.920	D	27	C 280 4-matic (203.092)	01.2005 → 02.2007	M 272.941	B	67
B 200 d 4-matic (247.013)	10.2019 →	OM 654.920	D	27	C 30 CDI AMG (203.018)	01.2003 → 02.2007	OM 612.990	D	70
B 220 (247.044)	04.2019 →	M 260.920	B	32	C 32 AMG Kompressor (203.065)	02.2001 → 02.2007	M 112.961	B	95
B 220 4-matic (247.045)	01.2019 →	M 260.920	B	32	C 320 (203.064)	05.2000 → 02.2007	M 112.946	B	95
B 220 d (247.014)	12.2018 →	OM 654.920	D	27	C 320 4-matic (203.084)	07.2002 → 02.2007	M 112.953	B	95
B 220 d 4-matic (247.015)	10.2019 →	OM 654.920	D	27	C 320 CDI (203.020)	01.2005 → 02.2007	OM 642.910	D	34
B 250 (247.046)	01.2019 →	M 260.920	B	32	C 350 (203.056)	01.2005 → 02.2007	M 272.960	B	111
B 250 4-matic (247.047)	01.2019 →	M 260.920	B	32	C 350 4-matic (203.087)	01.2005 → 02.2007	M 272.960	B	111
<b>C-CLASS (W202)</b>					C 350 4-matic (203.087)	01.2005 → 02.2007	M 272.970	B	111
C 180 (202.018)	03.1993 → 05.2000	M 111.920	B	52	C 55 AMG	09.2004 → 12.2005	M 113.988	B	127
C 180 (202.018)	03.1993 → 05.2000	M 111.921	B	52	C 55 AMG	09.2005 → 12.2006	M 113.988	B	127
C 180 (202.018)	11.1994 → 05.2000	M 111.921	B	52	C 55 AMG (203.076)	02.2004 → 02.2007	M 113.988	B	127
C 200 (202.020)	01.1994 → 05.2000	M 111.941	B	89	<b>G-CLASS (W204)</b>				
C 200 (202.020)	01.1994 → 05.2000	M 111.945	B	93	C 180 CDI (204.000)	04.2010 → 03.2014	OM 651.913	D	36
C 200 CDI (202.134)	03.1998 → 05.2000	OM 611.960	D	68	C 180 CGI (204.031)	01.2008 → 01.2014	M 274.910	B	31
C 200 D (202.120)	03.1993 → 05.2000	OM 601.913	D	64	C 180 CGI (204.049)	01.2007 → 01.2014	M 271.820	B	24
C 200 D (202.122)	10.1996 → 05.2000	OM 604.915	D	65	C 180 Kompressor (204.044, 204.045)	01.2008 → 01.2014	M 271.910	B	23
C 200 Kompressor (202.025)	10.1995 → 05.2000	M 111.944	B	94	C 180 Kompressor (204.046)	01.2007 → 01.2014	M 271.952	B	23
C 200 Kompressor (202.025)	11.1996 → 05.2000	M 111.944	B	94	C 200 (204.048)	05.2011 → 01.2014	M 271.820	B	24
C 220 (202.022)	03.1993 → 05.2000	M 111.961	B	92	C 200 CDI (204.001)	11.2009 → 03.2014	OM 651.913	D	36
C 220 CDI (202.133)	09.1997 → 05.2000	OM 611.960	D	68	C 200 CDI (204.007, 204.006)	01.2007 → 12.2009	OM 646.811	D	72
C 220 D (202.021)	07.1996 → 05.2000	OM 604.910	D	86	C 200 CDI (204.007, 204.006)	01.2007 → 12.2009	OM 646.812	D	72
C 220 D (202.121)	08.1993 → 05.2000	OM 604.910	D	86	C 200 CGI (204.048)	01.2007 → 01.2014	M 271.820	B	24
C 230 (202.023)	06.1996 → 06.1997	M 111.974	B	99	C 200 CGI (204.048)	01.2007 → 01.2014	M 271.860	B	24
C 230 (202.024)	09.1998 → 05.2000	M 111.975	B	99	C 200 Kompressor (204.041)	01.2007 → 01.2014	M 271.950	B	23
C 230 Kompressor (202.024)	10.1995 → 05.2000	M 111.975	B	99	C 220 CDI (204.002)	10.2008 → 01.2014	OM 651.911	D	36
C 240 (202.026)	06.1997 → 05.2000	M 112.910	B	47	C 220 CDI (204.002)	12.2008 → 01.2014	OM 651.911	D	36
C 250 D (202.125)	05.1993 → 05.2000	OM 605.910	D	65	C 220 CDI (204.008)	01.2007 → 11.2008	OM 646.811	D	72
C 250 Turbo-D (202.128)	10.1995 → 05.2000	OM 605.960	D	65	C 220 CDI (204.008)	01.2007 → 11.2008	OM 646.811	D	72
C 280 (202.028)	05.1993 → 05.2000	M 104.941	B	91	C 220 CDI 4-matic (204.084)	02.2013 → 01.2014	OM 651.912	D	36
C 280 (202.029)	06.1997 → 05.2000	M 112.920	B	95	C 230 (204.052)	01.2007 → 01.2014	M 272.921	B	67
C 36 AMG (202.028)	05.1994 → 05.2000	M 104.941 (AMG 3.6)	B	104	C 230 4-matic (204.085)	07.2007 → 01.2014	M 272.911	B	67
C 36 AMG (202.028)	09.1994 → 12.1996	M 104.941 (AMG 3.6)	B	104	C 250 CDI (204.003)	08.2008 → 01.2014	OM 651.911	D	36
C 43 AMG	09.1997 → 12.1998	M 113.944	B	95	C 250 CDI 4-matic (204.082)	01.2011 → 01.2014	OM 651.912	D	36
C 43 AMG (202.033)	08.1997 → 05.2000	M 113.944	B	95	C 250 CGI (204.047)	07.2009 → 01.2014	M 271.860	B	24
<b>C-CLASS (W203)</b>					C 280 (204.054)	01.2007 → 01.2014	M 272.947	B	67

M



		Pos			Pos
C 280 4-matic (204.081) 07.2007 → 01.2014	M 272.948 B	67	C 300 d (205.018) 06.2018 →	OM 654.920 D	27
C 300 (204.054) 07.2009 → 01.2014	M 272.947 B	67	C 300 d 4-matic (205.019) 06.2018 →	OM 654.920 D	27
C 300 (204.055) 02.2011 → 01.2014	M 276.957 B	113	C 300 de (205.013) 05.2019 →	OM 654.920 D	27
C 300 4-matic (204.080) 02.2011 → 01.2014	M 276.957 B	113	C 300 de (205.013) 05.2019 →	OM 654.920 D	27
C 300 4-matic (204.081) 07.2007 → 01.2014	M 272.948 B	67	C 300 e (205.053) 07.2019 →	M 274.920 BG	29
C 300 CDI 4-matic (204.092) 01.2011 → 01.2014	OM 642.832 D	34	C 300 e (205.053) 07.2019 →	M 274.920 BG	29
C 300 Flexfuel 01.2008 → 12.2012	M 272.947 B	67	C 300 e 4-matic (205.054) 07.2019 →	M 274.920 BG	29
C 320 CDI (204.022) 01.2007 → 01.2014	OM 642.960 D	34	C 300 e 4-matic (205.054) 07.2019 →	M 274.920 BG	29
C 320 CDI 4-matic (204.089) 07.2007 → 01.2014	OM 642.961 D	34	C 350 e (205.047) 02.2015 → 08.2018	M 274.920 BG	29
C 350 (204.056) 01.2007 → 01.2014	M 272.961 B	111	C 350 e (205.047) 02.2015 → 08.2018	M 274.920 BG	29
C 350 (204.057) 01.2011 → 01.2014	M 276.957 B	113	<b>C-CLASS Convertible (A205)</b>		
C 350 4-matic (204.087) 07.2007 → 01.2014	M 272.971 B	111	C 180 (205.440) 06.2016 →	M 274.910 B	31
C 350 4-matic (204.088) 01.2011 → 01.2014	M 276.957 B	113	C 180 (205.476) 06.2019 →	M 264.915 B	14
C 350 CDI (204.022) 07.2009 → 01.2014	OM 642.960 D	34	C 200 (205.442) 06.2016 → 05.2018	M 274.920 BG	29
C 350 CDI (204.023) 06.2011 → 01.2014	OM 642.834 D	34	C 200 (205.480) 08.2019 →	M 264.920 B	32
C 350 CDI (204.025) 10.2009 → 01.2014	OM 642.830 D	34	C 200 4-matic (205.443) 06.2016 → 05.2018	M 274.920 BG	29
C 350 CDI 4-matic (204.089) 07.2009 → 01.2014	OM 642.961 D	34	C 200 EQ Boost (205.477) 05.2018 →	M 264.915 B	14
C 350 CDI 4-matic (204.092) 10.2009 → 01.2014	OM 642.832 D	34	C 200 EQ Boost 4-matic (205.478) 05.2018 →	M 264.915 B	14
C 350 CGI (204.065) 09.2008 → 01.2014	M 272.982 B	112	C 200 d (205.401) 07.2018 →	OM 654.916 D	8
<b>C-CLASS (W205)</b>			C 220 d (205.404) 06.2016 → 05.2018	OM 651.921 D	39
C 160 (205.044) 04.2015 →	M 274.910 B	31	C 220 d (205.404) 06.2016 → 05.2018	OM 651.921 D	39
C 160 (205.075) 06.2019 →	M 264.915 B	14	C 220 d (205.414) 04.2018 →	OM 654.920 D	27
C 180 (205.040) 10.2018 →	M 274.910 B	31	C 220 d 4-matic (205.405) 06.2016 → 05.2018	OM 651.921 D	39
C 180 (205.040, 205.140) 03.2014 →	M 274.910 B	31	C 220 d 4-matic (205.415) 06.2018 →	OM 654.920 D	27
C 180 (205.076) 06.2019 →	M 264.915 B	14	C 250 (205.445) 06.2016 → 05.2018	M 274.920 BG	29
C 180 BlueTEC / d (205.036) 05.2014 → 05.2018	OM 626.951 D	13	C 250 d (205.408) 06.2016 → 05.2018	OM 651.921 D	39
C 180 Flex (205.040) 03.2014 →	M 274.910 B	31	C 300 (205.448) 06.2016 → 05.2018	M 274.920 BG	29
C 180 d (205.000) 05.2018 →	OM 654.916 D	8	C 300 (205.483) 05.2018 →	M 264.920 B	32
C 200 (205.042) 12.2013 → 08.2018	M 274.920 BG	29	C 300 4-matic (205.449) 01.2017 → 12.2018	M 274.920 BG	29
C 200 (205.080) 08.2019 →	M 264.920 B	32	C 300 4-matic (205.484) 05.2018 →	M 264.920 B	32
C 200 4-matic (205.043) 04.2015 → 08.2018	M 274.920 BG	29	C 300 EQ Boost (205.483) 05.2019 →	M 264.920 B	32
C 200 4-matic (205.079) 08.2019 →	M 264.920 B	32	C 300 EQ Boost 4-matic (205.484) 05.2019 →	M 264.920 B	32
C 200 BlueTEC / d (205.037) 05.2014 → 05.2018	OM 626.951 D	13	C 300 d (205.418) 07.2018 →	OM 654.920 D	27
C 200 EQ Boost (205.077) 04.2018 →	M 264.915 B	14	<b>C-CLASS Coupe (C204)</b>		
C 200 EQ Boost 4-matic (205.078) 04.2018 →	M 264.915 B	14	C 180 (204.331) 01.2013 →	M 274.910 B	31
C 200 d (205.001) 05.2018 →	OM 654.916 D	8	C 180 (204.349) 06.2011 →	M 271.820 B	24
C 200 d (205.007) 10.2015 → 05.2018	OM 651.921 D	39	C 200 CGI (204.348) 06.2011 →	M 271.860 B	24
C 200 d (205.011) 05.2018 →	OM 654.920 D	27	C 220 CDI (204.302) 06.2011 →	OM 651.911 D	36
C 220 BlueTEC / d (205.002, 205.004) 02.2014 → 05.2018	OM 651.921 D	39	C 220 CDI (204.302) 06.2011 →	OM 651.911 D	36
C 220 BlueTEC / d (205.003) 03.2014 → 05.2016	OM 651.921 D	39	C 250 (204.347) 06.2011 →	M 271.860 B	24
C 220 d (205.014) 05.2018 →	OM 654.920 D	27	C 250 CDI (204.303) 06.2011 →	OM 651.911 D	36
C 220 d 4-matic (205.005) 04.2015 → 05.2018	OM 651.921 D	39	C 300 4-matic 09.2012 → 12.2014	M 276.957 B	113
C 220 d 4-matic (205.015) 05.2018 →	OM 654.920 D	27	C 350 (204.357) 06.2011 →	M 276.957 B	113
C 250 (205.045) 03.2014 → 05.2018	M 274.920 BG	29	C 350 4-matic (204.388) 09.2013 →	M 276.957 B	113
C 250 BlueTEC / d (205.008, 205.006) 02.2014 → 05.2018	OM 651.921 D	39	<b>C-CLASS Coupe (C205)</b>		
C 250 BlueTEC / d 4-matic (205.009) 02.2014 → 05.2018	OM 651.921 D	39	C 180 (205.340) 10.2015 →	M 274.910 B	31
C 300 (205.048) 09.2015 → 08.2018	M 274.920 BG	29	C 180 (205.340) 11.2018 →	M 274.910 B	31
C 300 (205.083) 05.2018 →	M 264.920 B	32	C 180 (205.376) 06.2019 →	M 264.915 B	14
C 300 (205.083) 05.2018 →	M 264.920 B	32	C 200 (205.342) 10.2015 → 05.2018	M 274.920 BG	29
C 300 4-matic (205.049) 12.2013 → 08.2018	M 274.920 BG	29	C 200 (205.380) 08.2019 →	M 264.920 B	32
C 300 4-matic (205.084) 05.2018 →	M 264.920 B	32	C 200 4-matic (205.343) 04.2016 → 05.2018	M 274.920 BG	29
C 300 BlueTEC Hybrid / h (205.012) 05.2014 → 05.2018	OM 651.921 D	39	C 200 EQ Boost (205.377) 05.2018 →	M 264.915 B	14
C 300 EQ Boost (205.083) 05.2019 →	M 264.920 B	32	C 200 EQ Boost 4-matic (205.378) 05.2018 →	M 264.915 B	14
C 300 EQ Boost 4-matic (205.084) 05.2019 →	M 264.920 B	32	C 200 d (205.301) 07.2018 →	OM 654.916 D	8
			C 220 d (205.304) 10.2015 → 05.2018	OM 651.921 D	39
			C 220 d (205.304) 10.2015 → 05.2018	OM 651.921 D	39
			C 220 d (205.314) 04.2018 →	OM 654.920 D	27
			C 220 d 4-matic (205.305) 04.2016 → 05.2018	OM 651.921 D	39

			Pos				Pos		
C 220 d 4-matic (205.315)	06.2018 →	OM 654.920	D	27	C 180 (203.235)	03.2001 → 05.2002	M 111.951	B	97
C 250 (205.345)	10.2015 → 05.2018	M 274.920	BG	29	C 180 Kompressor (203.246)	05.2002 → 08.2007	M 271.946	B	21
C 250 d (205.308)	10.2015 → 05.2018	OM 651.921	D	39	C 200 CDI (203.204)	03.2001 → 08.2007	OM 611.962	D	68
C 250 d 4-matic (205.309)	04.2016 → 05.2018	OM 651.921	D	39	C 200 CDI (203.204, 203.207)	03.2001 → 08.2007	OM 611.962	D	68
C 300 (205.348)	10.2015 → 12.2018	M 274.920	BG	29	C 200 CDI (203.204, 203.207)	03.2001 → 08.2007	OM 646.962	D	73
C 300 (205.383)	05.2018 →	M 264.920	B	32	C 200 CDI (203.207)	04.2003 → 08.2007	OM 646.962	D	73
C 300 4-matic (205.349)	09.2016 → 12.2018	M 274.920	BG	29	C 200 CDI (203.207)	04.2003 → 08.2007	OM 646.963	D	73
C 300 4-matic (205.384)	05.2018 →	M 264.920	B	32	C 200 CGI Kompressor (203.243)	07.2003 → 08.2007	M 271.942	B	21
C 300 EQ Boost (205.383)	05.2019 →	M 264.920	B	32	C 200 Kompressor (203.242)	05.2002 → 08.2007	M 271.940	B	21
C 300 EQ Boost 4-matic (205.384)	05.2019 →	M 264.920	B	32	C 200 Kompressor (203.245)	03.2001 → 05.2002	M 111.955	B	96
C 300 d (205.318)	07.2018 →	OM 654.920	D	27	C 220 CDI (203.206)	03.2001 → 08.2007	OM 611.962	D	68
C 300 d 4-matic (205.319)	07.2018 →	OM 654.920	D	27	C 220 CDI (203.208)	02.2004 → 08.2007	OM 646.963	D	73
<b>C-CLASS Coupe (CL203)</b>					C 220 CDI (203.208)	08.2006 → 08.2007	OM 646.963	D	73
C 160 Kompressor (203.730)	05.2002 → 05.2008	M 271.921	B	21	C 230 (203.252)	01.2005 → 08.2007	M 272.920	B	67
C 180 (203.735)	03.2001 → 05.2002	M 111.951	B	97	C 230 Kompressor (203.240)	02.2004 → 08.2007	M 271.948	B	21
C 180 Kompressor (203.746)	05.2002 → 05.2008	M 271.946	B	21	C 240 (203.261)	03.2001 → 08.2007	M 112.912	B	95
C 200 CDI (203.707)	03.2003 → 05.2008	OM 646.962	D	73	C 240 4-matic (203.281)	07.2002 → 08.2007	M 112.916	B	95
C 200 CGI Kompressor (203.743)	03.2003 → 05.2008	M 271.942	B	21	C 270 CDI (203.216)	03.2001 → 08.2007	OM 612.962	D	70
C 200 Kompressor (203.742)	05.2002 → 05.2008	M 271.940	B	21	C 270 CDI (203.216)	03.2001 → 08.2007	OM 612.962	D	70
C 200 Kompressor (203.745)	03.2001 → 05.2002	M 111.955	B	96	C 280 (203.254)	01.2005 → 08.2007	M 272.940	B	67
C 220 (203.740)	05.2002 → 05.2008	M 271.940	B	21	C 280 4-matic (203.292)	01.2005 → 08.2007	M 272.941	B	67
C 220 CDI (203.706)	03.2001 → 01.2004	OM 611.962	D	68	C 30 CDI AMG (203.218)	01.2003 → 08.2007	OM 612.990	D	70
C 220 CDI (203.708)	02.2004 → 05.2008	OM 646.963	D	73	C 32 AMG Kompressor (203.265)	03.2001 → 08.2007	M 112.961	B	95
C 230 (203.752)	01.2005 → 05.2008	M 272.920	B	67	C 320 (203.264)	03.2001 → 08.2007	M 112.946	B	95
C 230 Kompressor (203.740)	05.2002 → 05.2008	M 271.948	B	21	C 320 4-matic (203.284)	07.2002 → 08.2007	M 112.953	B	95
C 230 Kompressor (203.747)	03.2001 → 05.2002	M 111.981	B	101	C 320 CDI (203.220)	06.2005 → 08.2007	OM 642.910	D	34
C 230 Kompressor (203.747)	09.2001 → 12.2002	M 111.981	B	101	C 350 (203.256)	01.2005 → 08.2007	M 272.960	B	111
C 30 CDI AMG (203.718)	09.2002 → 05.2008	OM 612.990	D	70	C 350 4-matic (203.287)	01.2005 → 08.2007	M 272.970	B	111
C 32 AMG Kompressor (203.765)	05.2002 → 05.2008	M 112.961	B	95	C 55 AMG (203.276)	02.2004 → 08.2007	M 113.988	B	127
C 320 (203.764)	09.2002 → 05.2008	M 112.946	B	95	<b>C-CLASS T-Model (S204)</b>				
C 350 (203.756)	01.2005 → 05.2008	M 272.960	B	111	C 180 (204.231)	02.2012 → 08.2014	M 274.910	B	31
<b>C-CLASS T-Model (S202)</b>					C 180 CDI (204.200)	01.2011 → 08.2014	OM 651.913	D	36
C 180 T (202.078)	06.1996 → 09.2000	M 111.920	B	52	C 180 CGI (204.249)	11.2009 → 08.2014	M 271.820	B	24
C 180 T (202.078)	06.1996 → 09.2000	M 111.921	B	52	C 180 Kompressor (204.245)	01.2008 → 08.2014	M 271.910	B	23
C 180 T (202.081)	09.2000 → 03.2001	M 111.952	B	97	C 180 Kompressor (204.246)	08.2007 → 08.2014	M 271.952	B	23
C 200 T (202.080)	06.1996 → 03.2001	M 111.941	B	89	C 200 CDI (204.201)	08.2010 → 08.2014	OM 651.913	D	36
C 200 T (202.080)	06.1996 → 03.2001	M 111.945	B	93	C 200 CDI (204.207)	08.2007 → 12.2009	OM 646.811	D	72
C 200 T CDI (202.194)	03.1998 → 03.2001	OM 611.960	D	68	C 200 CGI (204.248)	08.2007 → 08.2014	M 271.820	B	24
C 200 T D (202.180)	10.1996 → 03.2001	OM 604.915	D	65	C 200 CGI (204.248)	08.2007 → 08.2014	M 271.860	B	24
C 200 T Kompressor (202.082)	11.1996 → 03.2001	M 111.944	B	94	C 200 Kompressor (204.241)	08.2007 → 08.2014	M 271.950	B	23
C 200 T Kompressor (202.087)	09.2000 → 03.2001	M 111.956	B	96	C 220 CDI (204.202)	12.2008 → 08.2014	OM 651.911	D	36
C 220 T CDI (202.193)	09.1997 → 03.2001	OM 611.960	D	68	C 220 CDI (204.202)	12.2008 → 08.2014	OM 651.911	D	36
C 220 T D (202.182)	06.1996 → 09.1998	OM 604.910	D	86	C 220 CDI (204.208)	08.2007 → 11.2008	OM 646.811	D	72
C 220 T D (202.182)	06.1996 → 03.2001	OM 604.910	D	86	C 220 CDI (204.208)	08.2007 → 11.2008	OM 646.811	D	72
C 230 T (202.083)	06.1996 → 06.1998	M 111.974	B	99	C 220 CDI 4-matic (204.284)	02.2013 → 08.2014	OM 651.912	D	36
C 230 T Kompressor (202.085)	06.1997 → 09.2000	M 111.975	B	99	C 230 (204.252)	08.2007 → 08.2014	M 272.921	B	67
C 240 T (202.086)	06.1997 → 09.2000	M 112.910	B	47	C 250	03.2014 → 08.2014	M 274.920	BG	29
C 240 T (202.088)	09.2000 → 03.2001	M 112.915	B	95	C 250 (204.252)	02.2008 → 12.2012	M 272.921	B	67
C 250 T Turbo-D (202.188)	06.1996 → 03.2001	OM 605.960	D	65	C 250 CDI (204.203)	01.2009 → 08.2014	OM 651.911	D	36
C 280 T (202.089)	06.1997 → 03.2001	M 112.920	B	95	C 250 CDI 4-matic (204.282)	04.2010 → 08.2014	OM 651.912	D	36
C 43 AMG (202.093)	08.1997 → 03.2001	M 113.944	B	95	C 250 CGI (204.247)	07.2009 → 08.2014	M 271.860	B	24
<b>C-CLASS T-Model (S203)</b>					C 280 (204.254)	08.2007 → 08.2014	M 272.947	B	67
					C 300 (204.254)	08.2007 → 08.2014	M 272.947	B	67
					C 300 CDI 4-matic (204.292)	06.2011 → 08.2014	OM 642.832	D	34
					C 320 CDI (204.222)	08.2007 → 08.2014	OM 642.960	D	34
					C 320 CDI 4-matic (204.289)	08.2007 → 12.2011	OM 642.961	D	34

M

		Pos			Pos
C 350 (204.256) 08.2007 → 08.2014	M 272.961 B	111	111 CDI (415.703) 02.2019 →	OM 608.915 D	7
C 350 CDI (204.223) 06.2011 → 08.2014	OM 642.834 D	34	111 CDI (415.703, 06.2013 →	OM 607.951 D	6
C 350 CDI (204.225) 08.2007 → 08.2014	OM 642.830 D	34	415.705)		
C 350 CDI (204.225) 10.2009 → 08.2014	OM 642.830 D	34	112 (415.703) 06.2013 →	M 200.711 B	1
C 350 CDI 4-matic (204.289) 08.2007 → 12.2011	OM 642.961 D	34	<b>CL-KLASSE (C216)</b>		
C 350 CDI 4-matic (204.292) 10.2009 → 08.2014	OM 642.832 D	34	550 09.2006 →	M 273.961 B	237
C 350 CGI (204.257) 06.2011 → 08.2014	M 276.957 B	113	<b>CLA (C118)</b>		
<b>C-CLASS T-Model (S205)</b>					
C 160 (205.244) 04.2015 →	M 274.910 B	31	AMG CLA 35 4-matic (118.351) 04.2019 →	M 260.920 B	32
C 160 (205.275) 06.2019 →	M 264.915 B	14	CLA 180 d (118.303) 03.2019 →	OM 608.915 D	7
C 180 (205.240) 09.2014 →	M 274.910 B	31	CLA 180 d (118.310) 10.2020 →	OM 654.920 D	27
C 180 (205.276) 06.2019 →	M 264.915 B	14	CLA 200 d (118.312) 04.2019 →	OM 654.920 D	27
C 180 BlueTEC / d (205.236) 09.2014 → 05.2018	OM 626.951 D	13	CLA 200 d 4-matic (118.313) 04.2019 →	OM 654.920 D	27
C 180 Flex (205.240) 06.2015 →	M 274.910 B	31	CLA 220 (118.344) 03.2019 →	M 260.920 B	32
C 180 d (205.200) 05.2018 →	OM 654.916 D	8	CLA 220 4-matic (118.345) 03.2019 →	M 260.920 B	32
C 200 (205.242) 09.2014 → 05.2018	M 274.920 BG	29	CLA 220 d (118.314) 04.2019 →	OM 654.920 D	27
C 200 (205.280) 06.2018 →	M 264.920 B	32	CLA 220 d 4-matic (118.315) 07.2020 →	OM 654.920 D	27
C 200 4-matic (205.243) 04.2015 → 05.2018	M 274.920 BG	29	CLA 250 (118.346) 03.2019 →	M 260.920 B	32
C 200 BlueTEC / d (205.237) 09.2014 → 05.2018	OM 626.951 D	13	CLA 250 4-matic (118.347) 03.2019 →	M 260.920 B	32
C 200 EQ Boost (205.277) 04.2018 →	M 264.915 B	14	<b>CLA Coupe (C117)</b>		
C 200 EQ Boost 4-matic (205.278) 04.2018 →	M 264.915 B	14	CLA 180 (117.342) 01.2013 → 03.2019	M 270.910 B	31
C 200 d (205.201) 05.2018 →	OM 654.916 D	8	CLA 180 CDI / d (117.312) 10.2013 → 05.2018	OM 607.951 D	6
C 200 d (205.207) 10.2015 → 05.2018	OM 651.921 D	39	CLA 200 08.2015 → 03.2019	M 270.920 BG	29
C 200 d (205.211) 05.2018 →	OM 654.920 D	27	CLA 200 (117.343) 01.2013 → 03.2019	M 270.910 B	31
C 220 BlueTEC / d (205.204) 09.2014 → 05.2018	OM 651.921 D	39	CLA 200 (117.343) 07.2018 → 03.2019	M 270.910 B	31
C 220 BlueTEC / d (205.204) 09.2014 → 05.2018	OM 651.921 D	39	CLA 200 CDI (117.301) 06.2013 → 08.2014	OM 651.901 D	38
C 220 d (205.214) 04.2018 →	OM 654.920 D	27	CLA 200 CDI / d (117.308) 07.2014 → 03.2019	OM 651.930 D	39
C 220 d 4-matic (205.205) 04.2015 → 05.2018	OM 651.921 D	39	CLA 200 CDI / d 4-matic (117.302) 07.2014 → 03.2019	OM 651.930 D	39
C 220 d 4-matic (205.215) 05.2018 →	OM 654.920 D	27	CLA 200 Flex (117.305) 01.2013 → 03.2019	M 270.910 B	31
C 250 (205.245) 09.2014 → 05.2018	M 274.920 BG	29	CLA 220 (117.345) 04.2016 → 03.2019	M 270.920 BG	29
C 250 BlueTEC / d (205.208) 09.2014 → 05.2018	OM 651.921 D	39	CLA 220 4-matic (117.347) 04.2016 → 03.2019	M 270.920 BG	29
C 250 BlueTEC / d 4-matic (205.209) 10.2014 → 05.2018	OM 651.921 D	39	CLA 220 CDI / d (117.302) 01.2013 → 03.2019	OM 651.930 D	39
C 300 (205.248) 09.2015 → 05.2018	M 274.920 BG	29	CLA 220 CDI / d (117.303) 01.2013 → 03.2019	OM 651.930 D	39
C 300 (205.283) 05.2018 →	M 264.920 B	32	CLA 220 CDI / d (117.303) 09.2014 → 03.2019	OM 651.930 D	39
C 300 4-matic (205.249) 09.2015 → 05.2018	M 274.920 BG	29	CLA 220 CDI / d 4-matic (117.303) 08.2014 → 03.2019	OM 651.930 D	39
C 300 4-matic (205.284) 05.2018 →	M 264.920 B	32	CLA 220 CDI / d 4-matic (117.305) 09.2014 → 03.2019	OM 651.930 D	39
C 300 BlueTEC Hybrid / h (205.212) 10.2014 → 05.2018	OM 651.921 D	39	CLA 220 CDI 4-matic (117.305) 07.2014 → 03.2019	OM 651.930 D	39
C 300 EQ Boost (205.283) 05.2019 →	M 264.920 B	32	CLA 250 (117.344) 01.2013 → 03.2019	M 270.920 BG	29
C 300 EQ Boost 4-matic (205.284) 05.2019 →	M 264.920 B	32	CLA 250 (117.350) 07.2015 → 03.2019	M 270.920 BG	29
C 300 d (205.218) 06.2018 →	OM 654.920 D	27	CLA 250 4-matic (117.346) 07.2013 → 03.2019	M 270.920 BG	29
C 300 d 4-matic (205.219) 06.2018 →	OM 654.920 D	27	CLA 250 4-matic (117.351) 07.2015 → 03.2019	M 270.920 BG	29
C 300 de (205.213) 05.2019 →	OM 654.920 D	27	<b>CLA Shooting Brake (X117)</b>		
C 300 de (205.213) 05.2019 →	OM 654.920 D	27	CLA 180 (117.942) 01.2015 → 03.2019	M 270.910 B	31
C 300 e (205.253) 07.2019 →	M 274.920 BG	29	CLA 180 d (117.912) 07.2015 → 05.2018	OM 607.951 D	6
C 300 e (205.253) 07.2019 →	M 274.920 BG	29	CLA 200 (117.943) 01.2015 → 03.2019	M 270.910 B	31
C 350 e (205.247) 02.2015 → 05.2018	M 274.920 BG	29	CLA 200 CDI / d (117.908) 01.2015 → 03.2019	OM 651.930 D	39
C 350 e (205.247) 02.2015 → 05.2018	M 274.920 BG	29	CLA 200 CDI / d 4-matic (117.902) 01.2015 → 03.2019	OM 651.930 D	39
<b>CABRIOLET (W111, W112)</b>					
220 SEB (111.023) 09.1961 → 08.1965	M 127.984 B	9	CLA 220 4-matic (117.947) 04.2016 → 03.2019	M 270.920 BG	29
280 SE 3.5 (111.025) 04.1968 → 12.1971	M 116.980 B	107	CLA 220 CDI / d (117.903) 01.2015 → 03.2019	OM 651.930 D	39
<b>CITAN MPV (415)</b>					
108 CDI (415.703) 11.2012 →	OM 607.951 D	6	CLA 220 CDI / d (117.903) 01.2015 → 03.2019	OM 651.930 D	39
108 CDI (415.703) 02.2019 →	OM 608.915 D	7	CLA 220 CDI / d (117.903) 01.2015 → 03.2019	OM 651.930 D	39
109 CDI (415.703) 11.2012 →	OM 607.951 D	6			
109 CDI (415.703) 02.2019 →	OM 608.915 D	7			







		Pos			Pos
CLA 220 CDI / d 4-matic (117.905) 01.2015 → 03.2019	OM 651.930 D	39	320 (209.365) 06.2002 → 05.2009	M 112.955 B	95
CLA 220 CDI / d 4-matic (117.905) 09.2015 → 03.2019	OM 651.930 D	39	320 CDI (209.320) 01.2005 → 05.2009	OM 642.910 D	34
CLA 220 d (117.903) 07.2018 → 03.2019	OM 651.930 D	39	350 (209.356) 01.2005 → 05.2009	M 272.960 B	111
CLA 220 d 4-matic (117.905) 07.2018 → 03.2019	OM 651.930 D	39	500 09.2002 → 12.2005	M 113.968 B	127
CLA 250 (117.944) 01.2015 → 03.2019	M 270.920 BG	29	500 (209.372) 06.2006 → 05.2009	M 273.965 B	237
CLA 250 4-matic (117.946) 01.2015 → 03.2019	M 270.920 BG	29	500 (209.375) 06.2002 → 05.2009	M 113.968 B	127
CLA 250 4-matic (117.951) 07.2015 → 03.2019	M 270.920 BG	29	55 AMG 09.2002 → 12.2005	M 113.987 B	127
<b>CLA Shooting Brake (X118)</b>			55 AMG (209.376) 09.2002 → 05.2009	M 113.987 B	127
AMG CLA 35 4-matic (118.651) 06.2019 →	M 260.920 B	32	550 07.2006 → 05.2009	M 273.967 B	237
CLA 180 d (118.603) 06.2019 →	OM 608.915 D	7	<b>CLK Convertible (A208)</b>		
CLA 180 d (118.610) 10.2020 →	OM 654.920 D	27	200 (208.435) 03.1998 → 03.2002	M 111.941 B	89
CLA 200 d (118.612) 06.2019 →	OM 654.920 D	27	200 (208.435) 03.1998 → 03.2002	M 111.945 B	93
CLA 200 d 4-matic (118.613) 10.2019 →	OM 654.920 D	27	200 Kompressor (208.444) 06.2000 → 03.2002	M 111.956 B	96
CLA 220 (118.644) 06.2019 →	M 260.920 B	32	200 Kompressor (208.445) 03.1998 → 06.2000	M 111.944 B	94
CLA 220 d (118.614) 06.2019 →	OM 654.920 D	27	230 Kompressor (208.447) 03.1998 → 06.2000	M 111.973 B	99
CLA 220 d 4-matic (118.615) 10.2019 →	OM 654.920 D	27	230 Kompressor (208.447) 03.1998 → 06.2000	M 111.975 B	99
CLA 250 (118.646) 06.2019 →	M 260.920 B	32	230 Kompressor (208.448) 06.2000 → 03.2002	M 111.982 B	101
CLA 250 4-matic (118.647) 06.2019 →	M 260.920 B	32	320 (208.465) 03.1998 → 03.2002	M 112.940 B	95
<b>CLC-CLASS (CL203)</b>			430 (208.470) 09.1998 → 03.2002	M 113.943 B	95
CLC 160 (203.731) 02.2009 → 06.2011	M 271.911 B	25	55 AMG (208.474) 01.2000 → 03.2002	M 113.981 B	127
CLC 180 Kompressor (203.746) 05.2008 → 06.2011	M 271.946 B	21	55 AMG (208.474) 09.2001 → 03.2002	M 113.984 B	127
CLC 200 CDI (203.707) 05.2008 → 06.2011	OM 646.962 D	73	55 AMG (208.474) 09.2001 → 03.2002	M 113.984 B	127
CLC 200 Kompressor (203.741) 05.2008 → 06.2011	M 271.957 B	25	<b>CLK Convertible (A209)</b>		
CLC 220 CDI (203.708) 05.2008 → 06.2011	OM 646.963 D	73	CLK 200 CGI (209.343) 07.2003 → 03.2010	M 271.942 B	21
CLC 220 CDI (203.708) 05.2008 → 06.2011	OM 646.963 D	73	CLK 200 Kompressor (209.441) 10.2006 → 03.2010	M 271.955 B	22
CLC 230 (203.752) 05.2008 → 06.2011	M 272.920 B	67	CLK 200 Kompressor (209.442) 02.2003 → 03.2010	M 271.940 B	21
CLC 250 06.2009 → 06.2011	M 272.920 B	67	CLK 240 (209.461) 02.2003 → 03.2010	M 112.912 B	95
CLC 350 (203.756) 05.2008 → 06.2011	M 272.960 B	111	CLK 280 (209.454) 01.2005 → 03.2010	M 272.940 B	67
<b>CLK (C208)</b>			CLK 320 (209.465) 02.2003 → 03.2010	M 112.955 B	95
200 (208.335) 06.1997 → 06.2002	M 111.945 B	93	CLK 320 CDI (209.420) 03.2005 → 03.2010	OM 642.910 D	34
200 Kompressor (208.344) 06.2000 → 06.2002	M 111.956 B	96	CLK 350 (209.456) 01.2005 → 03.2010	M 272.960 B	111
200 Kompressor (208.345) 06.1997 → 06.2000	M 111.944 B	94	CLK 500 09.2003 → 12.2005	M 113.968 B	127
230 Kompressor (208.347) 06.1997 → 06.2000	M 111.973 B	99	CLK 500 (209.472) 06.2006 → 03.2010	M 273.967 B	237
230 Kompressor (208.347) 06.1997 → 06.2000	M 111.975 B	99	CLK 500 (209.475) 02.2003 → 03.2010	M 113.968 B	127
230 Kompressor (208.348) 06.2000 → 06.2002	M 111.982 B	101	CLK 55 AMG 09.2003 → 12.2005	M 113.987 B	127
320 (208.365) 06.1997 → 06.2002	M 112.940 B	95	CLK 55 AMG (209.476) 06.2002 → 03.2010	M 113.987 B	127
430 (208.370) 07.1998 → 06.2002	M 113.943 B	95	<b>CLS (C218)</b>		
5.4 10.1998 → 07.2002	M 113.984 B	127	CLS 220 BlueTEC / d (218.301) 05.2014 → 12.2017	OM 651.924 D	36
55 AMG 09.2000 → 12.2003	M 113.984 B	127	CLS 220 BlueTEC / d (218.301) 05.2014 → 12.2017	OM 651.924 D	36
55 AMG (208.374) 08.1999 → 06.2002	M 113.981 B	127	CLS 220 BlueTEC / d (218.301) 05.2014 → 12.2017	OM 651.924 D	36
55 AMG (208.374) 08.1999 → 06.2002	M 113.984 B	127	CLS 250 BlueTEC / d 4-matic (218.397) 05.2014 → 12.2017	OM 651.924 D	36
<b>CLK (C209)</b>			CLS 250 CDI / BlueTEC / d (218.303, 218.304) 04.2011 → 12.2017	OM 651.924 D	36
200 CGI (209.343) 07.2003 → 05.2009	M 271.942 B	21	CLS 260 (218.336) 01.2015 → 12.2017	M 274.920 BG	29
200 Kompressor (209.341) 10.2006 → 05.2009	M 271.955 B	22	CLS 300 (218.355) 10.2011 → 05.2014	M 276.952 B	113
200 Kompressor (209.342) 09.2002 → 05.2009	M 271.940 B	21	CLS 300 (218.355) 10.2011 → 05.2014	M 276.957 B	113
220 CDI (209.308) 01.2005 → 05.2009	OM 646.966 D	75	CLS 350 (218.359) 01.2011 → 08.2014	M 276.952 B	113
220 CDI (209.308) 01.2005 → 05.2009	OM 646.966 D	75	CLS 350 BlueTEC / d (218.326) 02.2013 → 12.2017	OM 642.852 D	37
240 (209.361) 06.2002 → 05.2009	M 112.912 B	95	CLS 350 BlueTEC / d (218.326) 02.2013 → 12.2017	OM 642.853 D	37
240 (209.361) 06.2002 → 05.2009	M 112.912 B	95	CLS 350 BlueTEC / d (218.326) 02.2013 → 12.2017	OM 642.853 D	37
270 CDI (209.316) 10.2002 → 05.2009	OM 612.962 D	70	CLS 350 BlueTEC / d (218.326) 06.2014 → 12.2017	OM 642.852 D	37
270 CDI (209.316) 10.2002 → 05.2009	OM 612.967 D	70	CLS 350 BlueTEC / d (218.326) 06.2014 → 12.2017	OM 642.853 D	37
270 CDI (209.316) 02.2003 → 06.2005	OM 612.967 D	70	CLS 350 BlueTEC / d 4-matic (218.394) 02.2013 → 12.2017	OM 642.854 D	37
280 (209.354) 01.2005 → 05.2009	M 272.940 B	67	CLS 350 BlueTEC / d 4-matic (218.394) 02.2013 → 12.2017	OM 642.858 D	37

M

		Pos			Pos
CLS 350 CDI / d (218.323) 01.2011 → 08.2014	OM 642.852 D	37	CLS 250 CDI / BlueTEC / d (218.903, 218.904) 10.2012 → 12.2017	OM 651.924 D	36
CLS 350 CDI / d (218.323) 01.2011 → 08.2014	OM 642.853 D	37	CLS 350 (218.959) 10.2012 → 08.2014	M 276.952 B	113
CLS 350 CDI / d 4-matic (218.393) 09.2011 → 08.2014	OM 642.854 D	37	CLS 350 BlueTEC / d (218.926) 05.2014 → 12.2017	OM 642.852 D	37
CLS 350 CDI / d 4-matic (218.393) 09.2011 → 08.2014	OM 642.858 D	37	CLS 350 BlueTEC / d (218.926) 05.2014 → 12.2017	OM 642.852 D	37
CLS 350 d 4-matic (218.394) 04.2015 → 12.2017	OM 642.854 D	37	CLS 350 BlueTEC / d (218.926) 05.2014 → 12.2017	OM 642.853 D	37
CLS 350 d 4-matic (218.394) 04.2015 → 12.2017	OM 642.858 D	37	CLS 350 BlueTEC / d (218.926) 05.2014 → 12.2017	OM 642.854 D	37
CLS 500 (218.373) 02.2011 → 12.2017	M 278.922 B	115	CLS 350 BlueTEC / d 4-matic (218.994) 05.2014 → 12.2017	OM 642.858 D	37
CLS 500 4-matic (218.391) 09.2011 → 12.2017	M 278.922 B	115	CLS 350 CDI / d (218.923) 10.2012 → 08.2014	OM 642.852 D	37
CLS 550 09.2011 → 12.2017	M 278.922 B	115	CLS 350 CDI / d 4-matic (218.993) 10.2012 → 08.2014	OM 642.853 D	37
CLS 550 4-matic 09.2011 → 12.2017	M 278.922 B	115	CLS 350 CDI / d 4-matic (218.993) 10.2012 → 08.2014	OM 642.854 D	37
CLS 63 AMG (218.374) 01.2011 → 12.2017	M 157.980 B	237	CLS 350 d 4-matic (218.994) 04.2015 → 12.2017	OM 642.854 D	37
CLS 63 AMG (218.374) 01.2011 → 12.2017	M 157.980 B	237	CLS 350 d 4-matic (218.994) 04.2015 → 12.2017	OM 642.858 D	37
CLS 63 AMG (218.374) 01.2011 → 12.2017	M 157.981 B	237	CLS 350 d 4-matic (218.994) 04.2015 → 12.2017	OM 642.858 D	37
CLS 63 AMG (218.374) 01.2011 → 12.2017	M 157.981 B	237	CLS 500 (218.973) 10.2012 → 12.2017	M 278.922 B	115
CLS 63 AMG (218.374) 09.2011 → 12.2017	M 157.980 B	237	CLS 500 4-matic (218.991) 10.2012 → 12.2017	M 278.922 B	115
CLS 63 AMG (218.374) 09.2011 → 12.2017	M 157.981 B	237	CLS 63 AMG (218.974) 10.2012 → 12.2017	M 157.981 B	237
CLS 63 AMG (218.375) 02.2013 → 12.2017	M 157.981 B	237	CLS 63 AMG (218.974) 05.2013 → 12.2017	M 157.981 B	237
CLS 63 AMG 4-matic (218.376) 02.2013 → 12.2017	M 157.981 B	237	CLS 63 AMG (218.975) 02.2013 → 12.2017	M 157.981 B	237
CLS 63 AMG 4-matic (218.392) 05.2013 → 12.2017	M 157.981 B	237	CLS 63 AMG 4-matic (218.976) 02.2013 → 12.2017	M 157.981 B	237
<b>CLS (C219)</b>			<b>COUPE (W111, W112)</b>		
CLS 280 (219.354) 07.2008 → 12.2010	M 272.943 B	67	220 SEB (111.021) 01.1961 → 12.1965	M 127.984 B	9
CLS 300 (219.354) 04.2009 → 12.2010	M 272.943 B	67	250 SE (111.021) 01.1965 → 12.1967	M 129.980 B	20
CLS 320 CDI 01.2005 → 12.2010	OM 642.920 D	34	250 SE (111.021) 01.1965 → 12.1967	M 129.981 B	20
CLS 320 CDI (219.322) 01.2005 → 12.2010	OM 642.920 D	34	280 SE (111.024) 01.1967 → 12.1971	M 130.980 B	57
CLS 350 (219.356) 10.2004 → 12.2010	M 272.964 B	111	280 SE (111.024) 01.1967 → 12.1971	M 130.984 B	57
CLS 350 (219.357) 04.2006 → 12.2010	M 272.985 B	112	280 SE 3.5 (111.026) 01.1969 → 12.1971	M 116.980 B	107
CLS 350 CDI 04.2009 → 12.2010	OM 642.920 D	34	<b>E-CLASS (W124)</b>		
CLS 350 CDI (219.322) 04.2009 → 12.2010	OM 642.920 D	34	E 200 (124.019) 06.1993 → 06.1995	M 111.940 B	89
CLS 500 09.2005 → 12.2006	M 113.967 B	127	E 200 D (124.120) 06.1993 → 06.1995	OM 601.912 D	60
CLS 500 (219.372) 04.2006 → 12.2010	M 273.960 B	237	E 220 (124.022) 06.1993 → 06.1995	M 111.960 B	92
CLS 500 (219.375) 10.2004 → 12.2010	M 113.967 B	127	E 250 D (124.126, 124.129) 07.1993 → 06.1995	OM 605.911 D	65
CLS 55 AMG 09.2005 → 12.2006	M 113.990 B	127	E 250 Turbo-D (124.128) 06.1993 → 06.1995	OM 602.962 D	61
CLS 55 AMG (219.376) 01.2005 → 12.2010	M 113.990 B	127	E 280 (124.028) 06.1993 → 06.1995	M 104.942 B	91
<b>CLS (C257)</b>			E 280 (124.029) 06.1993 → 06.1995	M 104.942 B	91
CLS 220 d (257.314) 06.2018 →	OM 654.920 D	27	E 300 4-matic (124.230) 06.1993 → 06.1995	M 103.985 B	76
CLS 260 EQ Boost (257.344) 05.2020 →	M 264.915 B	14	E 300 D (124.131) 07.1993 → 06.1995	OM 606.910 D	65
CLS 300 (257.348) 07.2018 →	M 264.920 B	32	E 300 Turbo-D (124.133) 06.1993 → 06.1995	OM 603.960 D	62
CLS 300 d (257.318) 04.2018 →	OM 654.920 D	27	E 300 Turbo-D 4-matic (124.333) 06.1993 → 06.1995	OM 603.963 D	62
CLS 350 EQ Boost (257.350) 08.2018 →	M 264.920 B	32	E 320 (124.032) 06.1993 → 06.1995	M 104.992 B	91
CLS 350 EQ Boost 4-matic (257.351) 08.2018 →	M 264.920 B	32	E 36 AMG 07.1994 → 01.1995	M 104.992 (AMG 3.6) B	104
CLS 350 d (257.320) 08.2018 →	OM 656.929 D	27	E 420 (124.034) 06.1993 → 06.1995	M 119.975 B	110
CLS 350 d 4-matic (257.321) 12.2017 →	OM 656.929 D	27	E 500 (124.036) 06.1993 → 06.1995	M 119.974 B	125
CLS 350 d 4-matic (257.321) 12.2017 →	OM 656.929 D	27	E 500 (124.036) 07.1993 → 10.1994	M 119.974 B	125
CLS 400 d 4-matic (257.323) 12.2017 →	OM 656.929 D	27	<b>E-CLASS (W210)</b>		
CLS 400 d 4-matic (257.323) 12.2017 →	OM 656.929 D	27	E 200 (210.035) 06.1995 → 08.2000	M 111.942 B	93
CLS 400 d 4-matic (257.323) 06.2020 →	OM 656.929 D	27	E 200 CDI (210.007) 06.1998 → 03.2002	OM 611.961 D	68
<b>CLS Shooting Brake (X218)</b>			E 200 CDI (210.007) 07.1999 → 03.2002	OM 611.961 D	68
CLS 220 BlueTEC / d (218.901) 05.2014 → 12.2017	OM 651.924 D	36	E 200 D (210.003) 01.1996 → 03.2002	OM 604.917 D	65
CLS 220 BlueTEC / d (218.901) 05.2014 → 12.2017	OM 651.924 D	36	E 200 Kompressor (210.045) 06.1997 → 03.2002	M 111.947 B	94
CLS 220 BlueTEC / d (218.901) 05.2014 → 12.2017	OM 651.924 D	36			
CLS 250 BlueTEC / d 4-matic (218.997) 05.2014 → 12.2017	OM 651.924 D	36			

M



				Pos					Pos
E 200 Kompressor (210.048)	08.2000 → 03.2002	M 111.957	B	<b>96</b>	E 350 (211.056)	03.2005 → 12.2008	M 272.964	B	<b>111</b>
E 220 CDI (210.006)	06.1998 → 07.1999	OM 611.961	D	<b>68</b>	E 350 4-matic (211.087)	08.2004 → 08.2006	M 272.972	B	<b>111</b>
E 220 CDI (210.006)	07.1999 → 03.2002	OM 611.961	D	<b>68</b>	E 350 4-matic (211.087)	03.2005 → 12.2008	M 272.972	B	<b>111</b>
E 220 CDI (210.006)	07.1999 → 03.2002	OM 611.961	D	<b>68</b>	E 350 CGI (211.057)	09.2007 → 12.2008	M 272.985	B	<b>112</b>
E 220 D	05.1996 → 03.2002	OM 604.912	D	<b>86</b>	E 400 CDI (211.028)	02.2003 → 12.2008	OM 628.961	D	<b>56</b>
E 220 D (210.004)	06.1995 → 07.1999	OM 604.912	D	<b>86</b>	E 420 CDI (211.029)	01.2006 → 12.2008	OM 629.910	D	<b>56</b>
E 230 (210.037)	06.1995 → 06.1997	M 111.970	B	<b>99</b>	E 500 (211.070)	03.2002 → 12.2008	M 113.967	B	<b>127</b>
E 240 (210.061)	06.1997 → 08.2000	M 112.911	B	<b>47</b>	E 500 (211.070)	09.2002 → 12.2005	M 113.967	B	<b>127</b>
E 240 (210.062)	08.2000 → 03.2002	M 112.914	B	<b>95</b>	E 500 (211.072)	04.2006 → 12.2008	M 273.960	B	<b>237</b>
E 250 D (210.010)	06.1995 → 07.1999	OM 605.912	D	<b>65</b>	E 500 4-matic (211.083)	10.2003 → 12.2008	M 113.969	B	<b>127</b>
E 250 Turbo-D (210.015)	06.1997 → 07.1999	OM 605.962	D	<b>65</b>	E 500 4-matic (211.090)	04.2006 → 12.2008	M 273.962	B	<b>237</b>
E 270 CDI (210.016)	07.1999 → 03.2002	OM 612.961	D	<b>70</b>	E 55 AMG Kompressor (211.076)	10.2002 → 12.2008	M 113.990	B	<b>127</b>
E 270 CDI (210.016)	07.1999 → 03.2002	OM 612.961	D	<b>70</b>	E320 CDI (211.022)	09.2006 → 12.2008	OM 642.920	D	<b>34</b>
E 280 (210.053)	01.1996 → 06.1997	M 104.945	B	<b>91</b>	<b>E-CLASS (W212)</b>				
E 280 (210.063)	12.1996 → 03.2002	M 112.921	B	<b>95</b>	E 180 (212.040)	08.2013 → 12.2015	M 274.910	B	<b>31</b>
E 280 4-matic (210.081)	12.1996 → 03.2002	M 112.921	B	<b>95</b>	E 200 (212.034)	01.2013 → 12.2016	M 274.920	BG	<b>29</b>
E 290 Turbo-D (210.017)	03.1996 → 07.1999	OM 602.982	D	<b>85</b>	E 200 CDI / BlueTEC (212.005, 212.006)	01.2009 → 12.2015	OM 651.925	D	<b>36</b>
E 300 D (210.020)	06.1995 → 06.1997	OM 606.912	D	<b>65</b>	E 200 CGI (212.048, 212.148)	08.2009 → 12.2015	M 271.820	B	<b>24</b>
E 300 Turbo-D (210.025)	03.1997 → 07.1999	OM 606.962	D	<b>65</b>	E 200 CGI (212.048, 212.148)	08.2009 → 12.2015	M 271.860	B	<b>24</b>
E 320 (210.055)	06.1995 → 06.1997	M 104.995	B	<b>91</b>	E 200 NGT (212.035)	07.2013 → 12.2015	M 274.920	BG	<b>29</b>
E 320 (210.065)	06.1997 → 03.2002	M 112.941	B	<b>95</b>	E 200 NGT (212.041)	03.2011 → 12.2015	M 271.958	BG	<b>18</b>
E 320 (210.065)	09.1997 → 12.1998	M 112.941	B	<b>95</b>	E 200 BlueTEC (212.001)	05.2014 → 12.2015	OM 651.924	D	<b>36</b>
E 320 4-matic (210.082)	06.1997 → 03.2002	M 112.941	B	<b>95</b>	E 220 BlueTEC 4-matic (212.011)	01.2015 → 12.2015	OM 651.924	D	<b>36</b>
E 320 4-matic (210.082)	09.1997 → 12.1998	M 112.941	B	<b>95</b>	E 220 CDI	01.2009 → 12.2015	OM 651.924	D	<b>36</b>
E 320 CDI (210.026)	07.1999 → 03.2002	OM 613.961	D	<b>70</b>	E 220 CDI / BlueTEC (212.001, 212.002)	01.2009 → 12.2016	OM 651.924	D	<b>36</b>
E 420 (210.072)	01.1996 → 06.1997	M 119.985	B	<b>110</b>	E 250 (212.036)	01.2013 → 12.2016	M 274.920	BG	<b>29</b>
E 430 (210.070)	06.1997 → 03.2002	M 113.940	B	<b>95</b>	E 250 CDI / BlueTEC (212.003, 212.004)	01.2009 → 12.2016	OM 651.924	D	<b>36</b>
E 430 4-matic (210.083)	05.1999 → 03.2002	M 113.940	B	<b>95</b>	E 250 CDI / BlueTEC (212.004)	01.2014 → 12.2015	OM 651.924	D	<b>36</b>
E 50 AMG (210.072)	02.1996 → 08.1997	M 119.985 (AMG 5.0)	B	<b>125</b>	E 250 CDI / BlueTEC (212.004) / BlueTEC 4-matic (212.082, 212.097)	01.2011 → 12.2015	OM 651.924	D	<b>36</b>
E 55 AMG	09.1997 → 02.2002	M 113.980	B	<b>127</b>	E 250 CDI / BlueTEC 4-matic (212.097)	07.2014 → 12.2015	OM 651.924	D	<b>36</b>
E 55 AMG (210.074)	08.1997 → 03.2002	M 113.980	B	<b>127</b>	E 250 CGI (212.047, 212.147)	01.2009 → 12.2015	M 271.860	B	<b>24</b>
E 55 AMG (210.074)	09.1997 → 12.1998	M 113.980	B	<b>127</b>	E 300 (212.054)	01.2009 → 12.2013	M 272.952	B	<b>67</b>
<b>E-CLASS (W211)</b>					E 300 (212.054)	01.2011 → 12.2015	M 272.952	B	<b>67</b>
E 200 CDI (211.004)	07.2002 → 12.2008	OM 646.951	D	<b>73</b>	E 300 (212.055)	07.2011 → 12.2015	M 276.952	B	<b>113</b>
E 200 CDI (211.004)	07.2002 → 12.2008	OM 646.951	D	<b>73</b>	E 300 4-matic (212.080)	07.2011 → 12.2015	M 276.952	B	<b>113</b>
E 200 CDI (211.007)	04.2006 → 12.2008	OM 646.820	D	<b>72</b>	E 300 CDI (212.020)	12.2009 → 12.2010	OM 642.850	D	<b>34</b>
E 200 Kompressor (211.041)	04.2006 → 12.2008	M 271.956	B	<b>21</b>	E 300 CDI / BlueTEC (212.020, 212.021, 212.027)	03.2011 → 12.2015	OM 642.850	D	<b>34</b>
E 200 Kompressor (211.042)	11.2002 → 12.2008	M 271.941	B	<b>21</b>	E 300 CDI / BlueTEC Hybrid (212.098)	12.2011 → 12.2016	OM 651.924	D	<b>36</b>
E 200 NGT (211.042)	03.2004 → 12.2008	M 271.941	B	<b>21</b>	E 350 (212.056)	01.2009 → 12.2013	M 272.980	B	<b>111</b>
E 220 CDI	03.2003 → 12.2008	OM 646.821	D	<b>72</b>	E 350 (212.059)	09.2011 → 12.2015	M 276.952	B	<b>113</b>
E 220 CDI (211.006)	03.2002 → 12.2008	OM 646.961	D	<b>73</b>	E 350 4-matic (212.087)	01.2009 → 08.2011	M 272.977	B	<b>112</b>
E 220 CDI (211.006)	03.2002 → 12.2008	OM 646.961	D	<b>73</b>	E 350 4-matic (212.088)	09.2011 → 12.2015	M 276.952	B	<b>113</b>
E 220 CDI (211.008)	04.2006 → 12.2008	OM 646.821	D	<b>72</b>	E 350 BlueTEC	01.2013 → 12.2015	OM 642.852	D	<b>37</b>
E 230 (211.052)	09.2007 → 12.2008	M 272.922	B	<b>67</b>	E 350 BlueTEC (212.024)	01.2009 → 12.2015	OM 642.850	D	<b>34</b>
E 240 (211.061)	03.2002 → 12.2008	M 112.913	B	<b>95</b>	E 350 BlueTEC (212.026)	05.2014 → 12.2015	OM 642.852	D	<b>37</b>
E 240 (211.061)	03.2002 → 12.2008	M 112.917	B	<b>95</b>	E 350 BlueTEC 4-matic (212.094)	01.2013 → 12.2015	OM 642.858	D	<b>37</b>
E 240 4-matic (211.080)	03.2003 → 12.2008	M 112.917	B	<b>95</b>	E 350 BlueTEC 4-matic (212.094)	05.2014 → 12.2015	OM 642.858	D	<b>37</b>
E 270 CDI (211.016)	03.2002 → 12.2008	OM 647.961	D	<b>72</b>	E 350 BlueTEC 4-matic (212.094)	05.2014 → 12.2015	OM 642.858	D	<b>37</b>
E 270 CDI (211.016)	03.2002 → 12.2008	OM 647.961	D	<b>72</b>	E 350 CDI	09.2010 → 12.2015	OM 642.850	D	<b>34</b>
E 280 (211.054)	03.2005 → 12.2008	M 272.943	B	<b>67</b>	E 350 CDI (212.023)	03.2011 → 12.2015	OM 642.852	D	<b>37</b>
E 280 4-matic (211.092)	01.2006 → 12.2008	M 272.943	B	<b>67</b>	E 350 CDI (212.025)	01.2009 → 12.2015	OM 642.850	D	<b>34</b>
E 280 4-matic (211.092)	01.2006 → 12.2008	M 272.944	B	<b>67</b>					
E 280 CDI (211.020)	03.2005 → 12.2008	OM 642.920	D	<b>34</b>					
E 280 CDI (211.023)	05.2004 → 12.2008	OM 648.961	D	<b>72</b>					
E 280 CDI 4-matic (211.084)	03.2005 → 12.2008	OM 642.921	D	<b>34</b>					
E 300 BlueTEC (211.024)	09.2007 → 12.2008	OM 642.920	D	<b>34</b>					
E 320 (211.065)	03.2002 → 12.2008	M 112.949	B	<b>95</b>					
E 320 4-matic (211.082)	03.2003 → 12.2008	M 112.954	B	<b>95</b>					
E 320 BlueTEC (211.022)	09.2008 → 03.2009	OM 642.920	D	<b>34</b>					
E 320 CDI (211.022)	03.2005 → 12.2008	OM 642.920	D	<b>34</b>					
E 320 CDI (211.026)	11.2002 → 12.2008	OM 648.961	D	<b>72</b>					
E 320 CDI 4-matic (211.089)	03.2005 → 12.2008	OM 642.910	D	<b>34</b>					
E 320 CDI 4-matic (211.089)	03.2005 → 12.2008	OM 642.921	D	<b>34</b>					

		Pos			Pos
E 350 CDI 4-matic (212.089) 09.2009 → 08.2011	OM 642.856	D 34	E 350 e (213.050) 07.2016 →	M 274.920	BG 29
E 350 CDI 4-matic (212.093) 03.2011 → 12.2015	OM 642.858	D 37	E 350 e (213.050) 07.2016 →	M 274.920	BG 29
E 350 CGI (212.057) 01.2009 → 08.2011	M 272.982	B 112	E 350 e (213.050) 11.2019 →	M 274.920	BG 29
E 350 CGI (212.057) 01.2009 → 08.2011	M 272.983	B 112	E 400 d (213.020) 12.2018 →	OM 656.929	D 27
E 350 Flexfuel (212.059) 01.2014 → 12.2015	M 276.952	B 113	E 400 d 4-matic (213.023) 04.2018 →	OM 656.929	D 27
E 350 Flexfuel 4-matic (212.088) 01.2014 → 12.2015	M 276.952	B 113	E 400 d 4-matic (213.023) 06.2020 →	OM 656.929	D 27
E 400 Hybrid (212.095) 05.2015 → 12.2015	M 276.952	B 113	<b>E-CLASS All-Terrain (S213)</b>		
E 500 (212.072) 01.2009 → 12.2011	M 273.971	B 237	E 200 EQ Boost (213.279) 08.2020 →	M 264.920	B 32
E 500 (212.073) 09.2011 → 12.2015	M 278.922	B 115	E 220 d 4-matic (213.217) 01.2017 →	OM 654.920	D 27
E 500 4-matic (212.090) 01.2009 → 12.2011	M 273.970	B 237	E 350 d 4-matic (213.237) 06.2017 →	OM 642.873	D 44
E 500 4-matic (212.091) 09.2011 → 12.2015	M 278.922	B 115	E 400 d 4-matic (213.227) 08.2018 →	OM 656.929	D 27
E 550 4-matic (212.091) 09.2011 → 12.2015	M 278.922	B 115	E 400 d 4-matic (213.227) 07.2020 →	OM 656.929	D 27
E 63 AMG (212.074) 02.2011 → 12.2016	M 157.980	B 237	<b>E-CLASS Convertible (A124)</b>		
E 63 AMG (212.074) 02.2011 → 12.2016	M 157.981	B 237	E 200 (124.060) 06.1993 → 03.1998	M 111.940	B 89
E 63 AMG (212.074) 02.2011 → 12.2016	M 157.981	B 237	E 220 (124.062) 06.1993 → 03.1998	M 111.960	B 92
E 63 AMG (212.075) 02.2013 → 12.2016	M 157.981	B 237	E 320 (124.066) 06.1993 → 03.1998	M 104.992	B 91
E 63 AMG 4-matic (212.076) 02.2013 → 12.2016	M 157.981	B 237	E 36 AMG (124.066) 05.1994 → 03.1998	M 104.992 (AMG 3.6)	B 104
E 63 AMG 4-matic (212.092) 01.2013 → 12.2016	M 157.981	B 237	<b>E-CLASS Convertible (A207)</b>		
<b>E-CLASS (W213)</b>			E 200 (207.434) 03.2013 → 12.2016	M 274.920	BG 29
E 180 (213.040) 01.2017 →	M 274.910	B 31	E 200 CGI (207.448) 01.2010 → 12.2016	M 271.820	B 24
E 200 (213.042) 01.2016 →	M 274.920	BG 29	E 200 CGI (207.448) 01.2010 → 12.2016	M 271.860	B 24
E 200 (213.080) 10.2018 →	M 264.920	B 32	E 220 BlueTEC (207.401) 05.2014 → 12.2016	OM 651.911	D 36
E 200 4-matic (213.043) 07.2016 →	M 274.920	BG 29	E 220 CDI (207.402) 02.2010 → 12.2016	OM 651.911	D 36
E 200 EQ Boost (213.080) 06.2019 →	M 264.920	B 32	E 220 CDI / BlueTEC / d (207.402, 207.401) 01.2010 → 12.2016	OM 651.911	D 36
E 200 EQ Boost 4-matic (213.087) 06.2019 →	M 264.920	B 32	E 250 (207.436) 06.2013 → 12.2016	M 274.920	BG 29
E 200 d (213.012) 11.2018 →	OM 654.916	D 8	E 250 CDI / BlueTEC / d (207.403, 207.404) 01.2010 → 12.2016	OM 651.911	D 36
E 200 d (213.013) 07.2016 →	OM 654.920	D 27	E 250 CGI (207.447) 01.2010 → 12.2016	M 271.860	B 24
E 220 d (213.004) 01.2016 →	OM 654.920	D 27	E 300 (207.455) 04.2011 → 12.2016	M 276.957	B 113
E 220 d (213.004) 01.2016 →	OM 654.920	D 27	E 350 (207.456) 03.2010 → 12.2011	M 272.961	B 111
E 220 d 4-matic (213.005) 10.2016 →	OM 654.920	D 27	E 350 (207.456) 03.2010 → 12.2011	M 272.988	B 111
E 220 d 4-matic (213.005) 10.2016 →	OM 654.920	D 27	E 350 (207.459) 04.2011 → 12.2014	M 276.957	B 113
E 250 (213.045) 07.2016 →	M 274.920	BG 29	E 350 BlueTEC (207.426) 06.2013 → 12.2016	OM 642.838	D 37
E 260 EQ Boost (213.077) 04.2019 →	M 264.915	B 14	E 350 BlueTEC / d (207.426) 05.2014 → 12.2016	OM 642.838	D 37
E 260 EQ Boost 4-matic (213.078) 04.2019 →	M 264.915	B 14	E 350 CDI (207.422) 01.2010 → 12.2011	OM 642.836	D 34
E 300 (213.048) 07.2016 →	M 274.920	BG 29	E 350 CDI (207.423) 04.2011 → 12.2013	OM 642.838	D 37
E 300 (213.048) 02.2019 →	M 274.920	BG 29	E 350 CGI (207.457) 01.2010 → 12.2014	M 272.982	B 112
E 300 (213.083) 04.2019 →	M 264.920	B 32	E 350 CGI (207.457) 01.2010 → 12.2014	M 272.984	B 112
E 300 4-matic (213.049) 09.2016 →	M 274.920	BG 29	E 350 Flexfuel (207.459) 01.2012 → 12.2014	M 276.957	B 113
E 300 EQ Boost (213.083) 06.2019 →	M 264.920	B 32	E 500 (207.472) 01.2010 → 12.2011	M 273.966	B 237
E 300 d (213.008) 12.2017 →	OM 654.920	D 27	E 500 (207.473) 09.2011 → 12.2016	M 278.922	B 115
E 300 de (213.016) 10.2018 →	OM 654.920	D 27	<b>E-CLASS Convertible (A238)</b>		
E 300 de (213.016) 10.2018 →	OM 654.920	D 27	E 200 (238.442) 06.2017 →	M 274.920	BG 29
E 300 de 4-matic (213.011) 06.2020 →	OM 654.920	D 27	E 200 4-matic (238.443) 10.2017 →	M 274.920	BG 29
E 300 de 4-matic (213.011) 06.2020 →	OM 654.920	D 27	E 200 EQ Boost (238.480) 06.2019 →	M 264.920	B 32
E 300 e (213.053) 11.2018 →	M 274.920	BG 29	E 200 EQ Boost 4-matic (238.487) 06.2019 →	M 264.920	B 32
E 300 e (213.053) 11.2018 →	M 274.920	BG 29	E 220 d (238.414) 06.2017 →	OM 654.920	D 27
E 300 e 4-matic (213.054) 07.2020 →	M 274.920	BG 29	E 220 d (238.414) 06.2017 →	OM 654.920	D 27
E 300 e 4-matic (213.054) 07.2020 →	M 274.920	BG 29	E 220 d 4-matic (238.415) 10.2017 →	OM 654.920	D 27
E 350 4-matic (213.086) 04.2019 →	M 264.920	B 32	E 260 EQ Boost (238.477) 12.2019 →	M 264.915	B 14
E 350 EQ Boost (213.085) 08.2018 →	M 264.920	B 32	E 260 EQ Boost 4-matic (238.478) 12.2019 →	M 264.915	B 14
E 350 d (213.022) 08.2018 →	OM 656.929	D 27	E 300 (238.448) 06.2017 →	M 274.920	BG 29
E 350 d (213.033) 01.2016 → 05.2018	OM 642.855	D 43	E 300 (238.483) 03.2019 →	M 264.920	B 32
E 350 d 4-matic (213.034) 06.2017 → 05.2018	OM 642.873	D 44	E 300 EQ Boost (238.483) 06.2019 →	M 264.920	B 32
			E 300 d (238.418) 05.2018 →	OM 654.920	D 27

M

					Pos						Pos
E 350 EQ Boost (238.485)	10.2017 →	M 264.920	B	32	E 400 d 4-matic (238.323)	08.2018 →	OM 656.929	D	27		
E 350 d (238.420)	11.2018 →	OM 656.929	D	27	E 400 d 4-matic (238.323)	07.2020 →	OM 656.929	D	27		
E 350 d 4-matic (238.434)	06.2017 →	OM 642.873	D	44	<b>E-CLASS T-Model (S124)</b>						
E 400 d 4-matic (238.423)	08.2018 →	OM 656.929	D	27	E 200 T (124.079)	06.1993 → 06.1996	M 111.940	B	89		
E 400 d 4-matic (238.423)	07.2020 →	OM 656.929	D	27	E 220 T (124.082)	06.1993 → 06.1996	M 111.960	B	92		
<b>E-CLASS Coupe (C124)</b>						E 250 TD (124.186)	06.1993 → 06.1996	OM 605.911	D	65	
E 200 (124.040)	06.1993 → 06.1997	M 111.940	B	89	E 250 Turbo D (124.088)	06.1993 → 06.1996	OM 602.962	D	61		
E 220 (124.042)	06.1993 → 06.1997	M 111.960	B	92	E 280 T (124.088)	06.1993 → 06.1996	M 104.942	B	91		
E 320 (124.052)	06.1993 → 06.1997	M 104.992	B	91	E 300 T 4-matic (124.290)	06.1993 → 06.1996	M 103.985	B	76		
E 36 AMG (124.052)	05.1994 → 06.1997	M 104.992 (AMG 3.6)	B	104	E 300 T Turbo-D (124.193)	06.1993 → 06.1996	OM 603.960	D	62		
<b>E-CLASS Coupe (C207)</b>						E 300 T Turbo-D 4-matic (124.393)	06.1993 → 06.1996	OM 603.963	D	62	
E 200 (207.334)	06.2013 → 12.2016	M 274.920	BG	29	E 300 TD (124.190)	06.1993 → 06.1996	OM 603.912	D	62		
E 200 CGI (207.348)	01.2010 → 12.2016	M 271.820	B	24	E 300 TD (124.191)	06.1993 → 06.1996	OM 606.910	D	65		
E 200 CGI (207.348)	01.2010 → 12.2016	M 271.860	B	24	E 320 T (124.092)	06.1993 → 06.1996	M 104.992	B	91		
E 220 BlueTEC (207.301)	05.2014 → 12.2016	OM 651.911	D	36	E 36 T AMG (124.092)	05.1994 → 06.1996	M 104.992 (AMG 3.6)	B	104		
E 220 CDI (207.302)	02.2010 → 12.2014	OM 651.911	D	36	<b>E-CLASS T-Model (S210)</b>						
E 220 CDI / d (207.302, 207.301)	01.2010 → 12.2016	OM 651.911	D	36	E 200 T (210.235)	06.1996 → 08.2000	M 111.942	B	93		
E 250 (207.336)	06.2013 → 12.2016	M 274.920	BG	29	E 200 T Kompressor (210.245)	06.1997 → 03.2003	M 111.947	B	94		
E 250 CDI / BlueTEC / d (207.303, 207.304)	01.2009 → 12.2016	OM 651.911	D	36	E 200 T Kompressor (210.248)	08.2000 → 03.2003	M 111.957	B	96		
E 250 CGI (207.347)	01.2009 → 12.2016	M 271.860	B	24	E 220 T CDI (210.206)	06.1998 → 07.1999	OM 611.961	D	68		
E 300 (207.355)	04.2011 → 06.2016	M 276.957	B	113	E 220 T CDI (210.206)	05.1999 → 03.2003	OM 611.961	D	68		
E 350 (207.356)	01.2010 → 12.2011	M 272.961	B	111	E 220 T CDI (210.206)	07.1999 → 03.2003	OM 611.961	D	68		
E 350 (207.356)	01.2010 → 12.2011	M 272.988	B	111	E 230 T (210.237)	06.1996 → 06.1997	M 111.970	B	99		
E 350 (207.359)	04.2011 → 12.2014	M 276.957	B	113	E 240 T (210.261)	06.1997 → 03.2003	M 112.911	B	47		
E 350 4-matic (207.388)	02.2013 → 12.2016	M 276.957	B	113	E 240 T (210.262)	08.2000 → 03.2003	M 112.914	B	95		
E 350 BlueTEC (207.326)	06.2013 → 12.2016	OM 642.838	D	37	E 250 T D (210.210)	06.1996 → 07.1999	OM 605.912	D	65		
E 350 BlueTEC / d (207.326)	05.2014 → 12.2016	OM 642.838	D	37	E 250 T Turbo-D (210.215)	06.1997 → 07.1999	OM 605.962	D	65		
E 350 CDI (207.322)	01.2009 → 06.2011	OM 642.836	D	34	E 270 T CDI	02.2000 → 03.2003	OM 612.961	D	70		
E 350 CDI (207.323)	06.2011 → 06.2013	OM 642.838	D	37	E 270 T CDI (210.216)	07.1999 → 03.2003	OM 612.961	D	70		
E 350 CGI (207.357)	01.2009 → 12.2011	M 272.982	B	112	E 280 T (210.263)	12.1996 → 03.2003	M 112.921	B	95		
E 350 CGI (207.357)	01.2009 → 12.2011	M 272.984	B	112	E 280 T 4-matic (210.281)	12.1996 → 03.2003	M 112.921	B	95		
E 350 Flexfuel (207.359)	04.2011 → 12.2014	M 276.957	B	113	E 290 T Turbo-D (210.217)	06.1996 → 07.1999	OM 602.982	D	85		
E 350 Flexfuel 4-matic (207.388)	04.2011 → 12.2014	M 276.957	B	113	E 300 T Turbo-D (210.225)	03.1997 → 07.1999	OM 606.962	D	65		
E 500 (207.372)	01.2009 → 12.2016	M 273.966	B	237	E 320	09.1997 → 12.1998	M 112.941	B	95		
E 500 (207.373)	09.2011 → 12.2016	M 278.922	B	115	E 320 T (210.265)	12.1996 → 03.2003	M 112.941	B	95		
<b>E-CLASS Coupe (C238)</b>						E 320 T 4-matic (210.282)	12.1996 → 03.2003	M 112.941	B	95	
E 200 (238.342)	12.2016 →	M 274.920	BG	29	E 320 T CDI (210.226)	07.1999 → 03.2003	OM 613.961	D	70		
E 200 4-matic (238.343)	06.2017 →	M 274.920	BG	29	E 420 T (210.272)	06.1996 → 06.1997	M 119.985	B	110		
E 200 EQ Boost (238.380)	06.2019 →	M 264.920	B	32	E 430 T (210.270)	06.1997 → 03.2003	M 113.940	B	95		
E 200 EQ Boost 4-matic (238.387)	06.2019 →	M 264.920	B	32	E 430 T 4-matic (210.283)	05.1999 → 03.2003	M 113.940	B	95		
E 220 d (238.314)	12.2016 →	OM 654.920	D	27	E 55 T AMG (210.274)	08.1997 → 03.2003	M 113.980	B	127		
E 220 d (238.314)	12.2016 →	OM 654.920	D	27	<b>E-CLASS T-Model (S211)</b>						
E 220 d 4-matic (238.315)	03.2017 →	OM 654.920	D	27	3.5 4-matic	08.2004 → 08.2006	M 272.972	B	111		
E 260 EQ Boost (238.377)	12.2019 →	M 264.915	B	14	350 CGI (211.257)	05.2006 → 07.2009	M 272.985	B	112		
E 260 EQ Boost 4-matic (238.378)	12.2019 →	M 264.915	B	14	E 200 CDI (211.207)	04.2006 → 07.2009	OM 646.821	D	72		
E 300 (238.348)	12.2016 →	M 274.920	BG	29	E 200 Kompressor (211.241)	04.2006 → 07.2009	M 271.956	B	21		
E 300 (238.383)	08.2018 →	M 264.920	B	32	E 200 T Kompressor (211.242)	03.2003 → 07.2009	M 271.941	B	21		
E 300 EQ Boost (238.383)	06.2019 →	M 264.920	B	32	E 220 CDI (211.206)	03.2003 → 07.2009	OM 646.961	D	73		
E 300 d (238.318)	05.2018 →	OM 654.920	D	27	E 220 T CDI	03.2003 → 07.2009	OM 646.821	D	72		
E 350 EQ Boost (238.385)	10.2017 →	M 264.920	B	32	E 220 T CDI (211.206)	03.2003 → 07.2009	OM 646.961	D	73		
E 350 EQ Boost 4-matic (238.386)	09.2018 →	M 264.920	B	32	E 220 T CDI (211.208)	04.2006 → 07.2009	OM 646.821	D	72		
E 350 d (238.320)	11.2018 →	OM 656.929	D	27	E 230 T (211.252)	05.2007 → 07.2009	M 272.922	B	67		
E 350 d 4-matic (238.334)	06.2017 →	OM 642.873	D	44	E 240 T (211.261)	03.2003 → 07.2009	M 112.913	B	95		



		Pos			Pos
E 240 T 4-matic (211.280) 07.2003 → 07.2009	M 112.917 B	95	E 350 BlueTEC 4-matic (212.294) 07.2014 → 12.2016	OM 642.852 D	37
E 270 T CDI (211.216) 03.2003 → 07.2009	OM 647.961 D	72	E 350 BlueTEC 4-matic (212.294) 07.2014 → 12.2016	OM 642.858 D	37
E 270 T CDI (211.216) 03.2003 → 07.2009	OM 647.961 D	72	E 350 CDI (212.223) 07.2011 → 12.2013	OM 642.852 D	37
E 280 T (211.254) 03.2005 → 07.2009	M 272.943 B	67	E 350 CDI (212.225) 11.2009 → 12.2011	OM 642.850 D	34
E 280 T 4-matic (211.292) 03.2005 → 07.2009	M 272.943 B	67	E 350 CDI 4-matic (212.289) 11.2009 → 12.2011	OM 642.856 D	34
E 280 T 4-matic (211.292) 03.2005 → 07.2009	M 272.944 B	67	E 350 CDI 4-matic (212.293) 07.2011 → 12.2013	OM 642.858 D	37
E 280 T CDI (211.220) 03.2005 → 07.2009	OM 642.920 D	34	E 350 CGI (212.257) 11.2009 → 12.2011	M 272.983 B	112
E 280 T CDI (211.223) 05.2004 → 07.2009	OM 648.961 D	72	E 350 Flexfuel 4-matic (212.288) 11.2009 → 12.2011	M 276.952 B	113
E 280 T CDI 4-matic (211.284) 03.2005 → 07.2009	OM 642.921 D	34	E 500 (212.272) 11.2009 → 12.2011	M 273.971 B	237
E 320 T (211.265) 03.2003 → 07.2009	M 112.949 B	95	E 500 (212.273) 09.2011 → 12.2016	M 278.922 B	115
E 320 T 4-matic (211.282) 07.2003 → 07.2009	M 112.954 B	95	E 500 4-matic (212.291) 09.2011 → 12.2016	M 278.922 B	115
E 320 T CDI (211.222) 03.2005 → 07.2009	OM 642.920 D	34	E 63 AMG (212.274) 02.2011 → 12.2016	M 157.981 B	237
E 320 T CDI (211.222) 11.2007 → 07.2009	OM 642.920 D	34	E 63 AMG (212.274) 02.2011 → 12.2016	M 157.981 B	237
E 320 T CDI (211.226) 03.2003 → 07.2009	OM 648.961 D	72	E 63 AMG (212.275) 02.2013 → 12.2016	M 157.981 B	237
E 320 T CDI 4-matic (211.289) 03.2005 → 07.2009	OM 642.921 D	34	E 63 AMG 4-matic (212.276) 02.2013 → 12.2016	M 157.981 B	237
E 350 T (211.256) 03.2005 → 07.2009	M 272.964 B	111	E 63 AMG 4-matic (212.292) 02.2011 → 12.2016	M 157.981 B	237
E 350 T 4-matic (211.287) 03.2005 → 07.2009	M 272.972 B	111	<b>E-CLASS T-Model (S213)</b>		
E 500 T (211.270) 10.2003 → 07.2009	M 113.967 B	127	E 200 (213.242) 07.2016 →	M 274.920 BG	29
E 500 T (211.272) 04.2006 → 07.2009	M 273.960 B	237	E 200 4-matic (213.243) 01.2017 →	M 274.920 BG	29
E 500 T 4-matic (211.283) 10.2003 → 07.2009	M 113.969 B	127	E 200 EQ Boost (213.280) 06.2019 →	M 264.920 B	32
E 500 T 4-matic (211.290) 04.2006 → 07.2009	M 273.962 B	237	E 200 EQ Boost 4-matic (213.287) 06.2019 →	M 264.920 B	32
E 55 T AMG Kompressor 09.2005 → 12.2006	M 113.990 B	127	E 200 d (213.212) 11.2018 →	OM 654.916 D	8
E 55 T AMG Kompressor 07.2003 → 07.2009	M 113.990 B	127	E 200 d (213.213) 10.2016 →	OM 654.920 D	27
<b>E-CLASS T-Model (S212)</b>			E 220 d (213.204) 07.2016 →	OM 654.920 D	27
E 200 (212.234) 11.2012 → 12.2016	M 274.920 BG	29	E 220 d (213.204) 07.2016 →	OM 654.920 D	27
E 200 CDI / BlueTEC (212.205, 212.206) 11.2009 → 12.2016	OM 651.925 D	36	E 220 d (213.206) 09.2020 →	OM 654.920 D	27
E 200 CGI (212.248) 11.2009 → 12.2016	M 271.860 B	24	E 220 d 4-matic (213.205) 01.2017 →	OM 654.920 D	27
E 220 BlueTEC 05.2015 → 12.2016	OM 651.924 D	36	E 250 (213.245) 07.2016 →	M 274.920 BG	29
E 220 BlueTEC 4-matic (212.211) 12.2014 → 12.2016	OM 651.924 D	36	E 300 EQ Boost (213.283) 06.2019 →	M 264.920 B	32
E 220 CDI (212.202) 08.2009 → 08.2014	OM 651.924 D	36	E 300 d (213.208) 12.2017 →	OM 654.920 D	27
E 220 CDI / BlueTEC (212.202, 212.201) 11.2009 → 12.2016	OM 651.924 D	36	E 300 de (213.216) 10.2018 →	OM 654.920 D	27
E 250 (212.236) 11.2012 → 12.2016	M 274.920 BG	29	E 300 de (213.216) 10.2018 →	OM 654.920 D	27
E 250 CDI / BlueTEC (212.203, 212.204) 11.2009 → 12.2016	OM 651.924 D	36	E 300 de 4-matic (213.211) 08.2020 →	OM 654.920 D	27
E 250 CDI / BlueTEC 4-matic (212.282, 212.297) 07.2010 → 12.2016	OM 651.924 D	36	E 300 de 4-matic (213.211) 08.2020 →	OM 654.920 D	27
E 250 CGI (212.247) 11.2009 → 12.2013	M 271.860 B	24	E 300 e (213.253) 06.2020 →	M 274.920 BG	29
E 300 (212.254) 11.2009 → 12.2011	M 272.952 B	67	E 300 e (213.253) 06.2020 →	M 274.920 BG	29
E 300 (212.255) 07.2011 → 12.2016	M 276.952 B	113	E 350 d (213.222) 08.2018 →	OM 656.929 D	27
E 300 4-matic (212.280) 07.2011 → 12.2016	M 276.952 B	113	E 350 d (213.233) 10.2016 →	OM 642.855 D	43
E 300 CDI (212.220) 12.2009 → 12.2010	OM 642.850 D	34	E 350 d 4-matic (213.234) 06.2017 →	OM 642.873 D	44
E 300 CDI / BlueTEC (212.227, 212.221) 11.2009 → 12.2016	OM 642.850 D	34	E 400 d (213.220) 02.2019 →	OM 656.929 D	27
E 300 CDI / BlueTEC (212.227, 212.221) 11.2009 → 12.2016	OM 642.852 D	37	E 400 d 4-matic (213.223) 04.2018 →	OM 656.929 D	27
E 300 Hybrid / BlueTEC Hybrid (212.298) 12.2011 → 12.2016	OM 651.924 D	36	E 400 d 4-matic (213.223) 07.2020 →	OM 656.929 D	27
E 350 (212.256) 08.2009 → 12.2011	M 272.980 B	111	<b>E-KLASSE (A207/C207)</b>		
E 350 (212.259) 09.2011 → 12.2014	M 276.952 B	113	300 CDI 01.2009 →	OM 642.836 D	34
E 350 4-matic (212.287) 11.2009 → 12.2011	M 272.977 B	112	<b>E-KLASSE (S211/W211)</b>		
E 350 4-matic (212.288) 09.2011 → 12.2016	M 276.952 B	113	200 CGI 11.2002 → 12.2008	M 271.946 B	21
E 350 BlueTEC 11.2012 → 12.2016	OM 642.852 D	37	250 CDI 02.2008 → 07.2009	OM 651.924 D	36
E 350 BlueTEC (212.224) 11.2009 → 12.2013	OM 642.850 D	34	550 06.2006 → 07.2009	M 273.960 B	237
E 350 BlueTEC (212.226) 07.2014 → 12.2016	OM 642.852 D	37	550 06.2006 → 07.2009	M 273.962 B	237
E 350 BlueTEC 4-matic (212.294) 11.2012 → 12.2016	OM 642.858 D	37	<b>G-CLASS (W460)</b>		
			200 G 07.1982 → 08.1989	M 102.964 B	79
			230 03.1979 → 07.1993	M 115.973 B	117
			230 04.1982 → 08.1992	M 102.981 B	118
			230 04.1982 → 08.1992	M 102.987 B	119
			230 04.1982 → 08.1992	M 102.989 B	119

				Pos					Pos
230	05.1987 → 08.1992	M 102.979	B	119	G 36 AMG (463.230)	01.1995 → 07.1998	M 104.996 (AMG B 3.6)	B	105
230 G (460,2)	03.1979 → 07.1993	M 115.973	B	117	G 400 CDI (463.332, 463.333)	12.2000 → 07.2006	OM 628.962	D	56
230 G (460,2)	02.1980 → 07.1987	M 115.973	B	117	G 400 d 4-matic (463.350)	07.2019 →	OM 656.929	D	27
230 GE (460,2)	04.1982 → 08.1992	M 102.981	B	118	G 500 (463.222, 463.236, 463.237, 463.242)	05.2008 →	M 273.963	B	237
230 GE (460,2)	04.1982 → 08.1992	M 102.987	B	119	G 500 (463.247, 463.248, 463.249, 463.240, 463.241, ...)	04.1998 →	M 113.962	B	127
230 GE (460,2)	04.1982 → 08.1992	M 102.989	B	119	G 500 (463.249)	09.2004 → 12.2005	M 113.962	B	127
230 GE (460,2)	05.1987 → 08.1992	M 102.979	B	119	G 55 AMG (463.243, 463.246)	04.1999 →	M 113.982	B	127
230 GE (460,2)	05.1987 → 08.1992	M 102.987	B	119	G 55 AMG (463.270, 463.271)	06.2004 →	M 113.993	B	127
240 D	03.1979 → 08.1987	OM 616.936	D	102	G 55 AMG (463.270, 463.271)	09.2004 → 12.2011	M 113.993	B	127
240 GD (460,3)	03.1979 → 08.1987	OM 616.936	D	102	G 55 AMG (463.270, 463.271)	08.2006 → 12.2012	M 113.993	B	127
250 D	10.1987 → 12.1992	OM 602.930	D	61	G 55 AMG (463.270, 463.271)	08.2008 →	M 113.993	B	127
250 GD (460,3)	10.1987 → 12.1992	OM 602.930	D	61	<b>G-CLASS Cabrio (W460)</b>				
250 GD (460,3)	12.1988 → 08.1992	OM 602.930	D	61	200 GE (460.216)	07.1982 → 08.1989	M 102.964	B	79
280	11.1979 → 08.1989	M 110.994	B	54	230 G (460.210, 460.241)	02.1980 → 07.1987	M 115.973	B	117
280 GE (460,2)	11.1979 → 08.1989	M 110.994	B	54	230 GE (460.218, 460.249)	07.1982 → 05.1993	M 102.981	B	118
280 GE (460,2)	08.1984 → 08.1989	M 110.994	B	54	230 GE (460.218, 460.249)	08.1986 → 05.1993	M 102.987	B	119
300 GD (460,3)	12.1979 → 12.1991	OM 617.931	D	102	230 GE (460.218, 460.249)	08.1986 → 05.1993	M 102.998	B	118
<b>G-CLASS (W461)</b>					240 GD (460.310, 460.341)	03.1979 → 08.1989	OM 616.936	D	102
230 GE (461)	06.1993 → 07.2000	M 102.996	B	119	240 GD (460.310, 460.341)	03.1979 → 08.1989	OM 616.938	D	102
230 GE (461)	06.1993 → 07.2000	M 102.997	B	119	250 GD (460.317)	10.1987 → 10.1991	OM 602.930	D	61
230 GE (461.238, 461.239)	09.1989 → 07.1996	M 102.979	B	119	280 GE (460.212, 460.243)	11.1979 → 06.1982	M 110.994	B	54
250 GD (461)	02.1990 → 05.1993	OM 602.939	D	61	280 GE (460.212, 460.243)	07.1982 → 05.1993	M 110.994	B	54
290 GD/G 290 D (461.337, 461.338)	06.1993 → 07.2000	OM 602.942	D	82	300 GD (460.312, 460.343)	11.1979 → 08.1989	OM 617.931	D	102
G 270 CDI	01.2003 →	OM 612.966	D	70	300 GD (460.312, 460.343)	11.1979 → 08.1989	OM 617.932	D	102
G 280 CDI (461.304, 461.346, 461.370, 461.334, 461.339, ...)	04.2009 →	OM 642.884	D	34	<b>G-CLASS Cabrio (W463)</b>				
G 280 CDI (461.304, 461.346, 461.370, 461.334, 461.339, ...)	04.2009 →	OM 642.975	D	34	200 GE (463.200)	01.1990 → 07.1993	M 102.965	B	79
G 290 TD (461.335, 461.336)	07.1997 →	OM 602.983	D	85	200 GE (463.200)	01.1990 → 07.1993	M 102.965	B	79
G 300 CDI (461.333)	04.2010 →	OM 642.884	D	34	230 GE (463.204)	06.1990 → 02.1993	M 102.989	B	119
<b>G-CLASS (W463)</b>					300 GE (463.207)	09.1989 → 09.1997	M 103.987	B	76
200 GE (463.220)	01.1990 → 07.1993	M 102.965	B	79	320 GE (463.208)	09.1994 → 11.1997	M 104.996	B	91
230 GE (463.224, 463.225)	06.1990 → 06.1993	M 102.989	B	119	350 G Turbo-D (463.300)	09.1991 → 09.1997	OM 603.972	D	84
250 GD (463.324, 463.325)	06.1990 → 10.1992	OM 602.931	D	61	G 300 Diesel (463.307)	09.1993 → 08.1994	OM 603.931	D	62
300 GD (463.327, 463.328)	09.1989 → 08.1993	OM 603.931	D	62	G 300 TD (463.308)	09.1996 → 07.2000	OM 606.964	D	65
300 GE (463.227, 463.228)	09.1989 → 08.1993	M 103.987	B	76	G 320 (463.209, 463.250)	11.1997 →	M 112.945	B	95
300 GE (463.227, 463.228)	06.1990 → 08.1997	M 103.987	B	76	G 320 (463.250)	11.1997 → 08.2004	M 112.945	B	95
350 Turbo GD (463.320, 463.321)	09.1991 → 08.1996	OM 603.972	D	84	G 320 CDI (463.303)	09.2006 →	OM 642.970	D	34
500 GE (463.228)	09.1993 → 12.1994	M 117.965	B	123	G 320 CDI (463.320)	09.1996 → 08.1999	OM 603.972	D	84
G 270 CDI (463.322, 463.323)	10.2001 → 07.2003	OM 612.965	D	70	G 350 CDI	07.2011 →	OM 642.886	D	34
G 300 (463.228, 463.227)	06.1993 → 08.1997	M 103.987	B	76	G 350 CDI (463.306)	06.2009 → 12.2011	OM 642.970	D	34
G 300 Diesel (463.327, 463.328)	09.1993 → 08.1994	OM 603.931	D	62	G 400 CDI (463.309)	12.2000 →	OM 628.962	D	56
G 300 TD (463.330, 463.331)	09.1996 → 07.2000	OM 606.964	D	65	G 500 (463)	04.1998 →	M 113.962	B	127
G 320 (463.230, 463.231)	09.1994 → 12.1997	M 104.996	B	91	G 500 (463.202)	12.2009 →	M 273.963	B	237
G 320 (463.232, 463.233, 463.244, 463.245)	11.1997 → 08.2004	M 112.945	B	95	<b>GL-CLASS (X164)</b>				
G 320 CDI (463.321)	09.1996 → 08.1999	OM 603.972	D	84	GL 320 CDI / 350	12.2009 → 08.2012	OM 642.820	D	34
G 320 CDI (463.340, 463.341, 463.343)	09.2006 →	OM 642.970	D	34	BlueTEC 4-matic (164.824, 164.825)				
G 350 (463.210)	09.2020 →	M 264.920	B	32	GL 320 CDI 4-matic	09.2006 → 12.2009	OM 642.940	D	34
G 350 CDI	07.2011 →	OM 642.886	D	34					
G 350 CDI (463.306)	06.2009 → 12.2011	OM 642.970	D	34					
G 350 d (463.348)	06.2015 →	OM 642.887	D	37					
G 350 d 4-matic (463.349)	01.2019 →	OM 656.929	D	27					

M



			Pos				Pos	
GL 320 CDI 4-matic (164.822)	09.2006 → 05.2009	OM 642.940	D	34	GLA 250 Flex 4-matic (156.946)	M 270.920	BG	29
GL 350 CDI 4-matic (164.822)	09.2009 → 12.2010	OM 642.820	D	34	<b>GLB (X247)</b>			
GL 350 CDI 4-matic (164.822)	05.2009 → 08.2012	OM 642.940	D	34	AMG GLB 35 4-matic (247.651)	M 260.920	B	32
GL 350 CDI 4-matic (164.823)	10.2010 → 08.2012	OM 642.822	D	34	GLB 180 d (247.610)	OM 654.920	D	27
GL 420 CDI 4-matic (164.828)	09.2006 → 05.2009	OM 629.912	D	56	GLB 200 d (247.612)	OM 654.920	D	27
GL 450 4-matic (164.871)	09.2006 → 08.2012	M 273.923	B	111	GLB 200 d 4-matic (247.613)	OM 654.920	D	27
GL 450 CDI 4-matic (164.828)	05.2009 → 08.2012	OM 629.912	D	56	GLB 220 d (247.614)	OM 654.920	D	27
GL 500 4-matic (164.886)	09.2006 → 12.2012	M 273.963	B	237	GLB 220 d 4-matic (247.615)	OM 654.920	D	27
<b>GL-CLASS (X166)</b>				<b>GLC (X253)</b>				
GL 350 CDI / BlueTEC 4-matic (166.824)	07.2012 → 10.2015	OM 642.826	D	34	200 (253.942)	M 274.920	BG	29
GL 350 CDI / BlueTEC 4-matic (166.824)	07.2012 → 10.2015	OM 642.826	D	34	200 4-matic (253.943)	M 274.920	BG	29
GL 350 CDI / BlueTEC 4-matic (166.823, 166.824)	07.2012 → 10.2015	OM 642.826	D	34	200 EQ Boost (253.980)	M 264.920	B	32
GL 450 4-matic (166.872)	07.2012 → 10.2015	M 278.928	B	113	200 EQ Boost 4-matic (253.981)	M 264.920	B	32
GL 500 4-matic (166.873)	07.2012 → 10.2015	M 278.928	B	113	200 d (253.913)	OM 654.920	D	27
GL 500 4-matic (166.873)	07.2014 → 10.2015	M 278.928	B	113	200 d 4-matic (253.916)	OM 654.920	D	27
<b>GLA (H247)</b>				<b>GLC Coupe (C253)</b>				
AMG GLA 35 4-matic (247.751)	06.2020 →	M 260.920	B	32	220 d 4-matic (253.915)	OM 654.920	D	27
GLA 180 d (247.710)	03.2020 →	OM 654.920	D	27	250 4-matic (253.946)	M 274.920	BG	29
GLA 200 d (247.712)	02.2020 →	OM 654.920	D	27	250 CNG 4-matic (253.946)	M 274.920	BG	29
GLA 200 d 4-matic (247.713)	02.2020 →	OM 654.920	D	27	250 Flexfuel 4-matic (253.946)	M 274.920	BG	29
GLA 220 d (247.714)	02.2020 →	OM 654.920	D	27	250 d 4-matic (253.909)	OM 651.921	D	39
GLA 220 d 4-matic (247.715)	02.2020 →	OM 654.920	D	27	300 (253.948)	M 274.920	BG	29
GLA 250 (247.746)	02.2020 →	M 260.920	B	32	300 4-matic (253.949)	M 274.920	BG	29
GLA 250 4-matic (247.747)	02.2020 →	M 260.920	B	32	300 4-matic (253.949)	M 274.920	BG	29
<b>GLA-CLASS (X156)</b>				<b>GLC (X253)</b>				
GLA 180 (156.942)	02.2015 →	M 270.910	B	31	300 EQ Boost (253.983)	M 264.920	B	32
GLA 180 CDI / d (156.912)	07.2014 →	OM 607.951	D	6	300 EQ Boost 4-matic (253.984)	M 264.920	B	32
GLA 200 (156.943)	12.2013 →	M 270.910	B	31	300 d 4-matic (253.919)	OM 654.920	D	27
GLA 200 (156.943)	07.2018 →	M 270.910	B	31	300 de 4-matic (253.911)	OM 654.920	D	27
GLA 200 (156.945)	09.2014 →	M 270.920	BG	29	300 de 4-matic (253.911)	OM 654.920	D	27
GLA 200 CDI / d (156.908)	12.2013 →	OM 651.930	D	39	300 e 4-matic (253.953)	M 274.920	BG	29
GLA 200 CDI 4-matic (156.902)	12.2013 →	OM 651.930	D	39	300 e 4-matic (253.953)	M 274.920	BG	29
GLA 200 Flex (156.945)	06.2015 →	M 270.910	B	31	350 d 4-matic (253.925)	OM 642.873	D	44
GLA 220 4-matic (156.947)	01.2017 →	M 270.920	BG	29	350 e 4-matic (253.954)	M 274.920	BG	29
GLA 220 CDI (156.903)	12.2013 →	OM 651.930	D	39	350 e 4-matic (253.954)	M 274.920	BG	29
GLA 220 CDI / d (156.903)	12.2013 →	OM 651.930	D	39	400 d 4-matic (253.923)	OM 656.929	D	27
GLA 220 CDI / d 4-matic (156.905)	12.2013 →	OM 651.930	D	39	<b>GLC Coupe (C253)</b>			
GLA 220 CDI 4-matic (156.905)	12.2013 →	OM 651.930	D	39	200 (253.342)	M 274.920	BG	29
GLA 220 d (156.903)	07.2015 →	OM 651.930	D	39	200 4-matic (253.343)	M 274.920	BG	29
GLA 220 d 4-matic (156.905)	07.2015 →	OM 651.930	D	39	200 EQ Boost (253.380)	M 264.920	B	32
GLA 250 (156.944)	12.2013 →	M 270.920	BG	29	200 EQ Boost 4-matic (253.381)	M 264.920	B	32
GLA 250 (156.944)	09.2020 →	M 270.920	BG	29	200 d (253.313)	OM 654.920	D	27
GLA 250 4-matic (156.946)	12.2013 →	M 270.920	BG	29	200 d 4-matic (253.316)	OM 654.920	D	27
GLA 250 Flex (156.944)	01.2015 →	M 270.920	BG	29	220 d 4-matic (253.303, 253.305)	OM 651.921	D	39
					220 d 4-matic (253.303, 253.305)	OM 651.921	D	39
					220 d 4-matic (253.315)	OM 654.920	D	27
					250 4-matic (253.346)	M 274.920	BG	29
					250 d 4-matic (253.309)	OM 651.921	D	39
					260 4-matic (253.381)	M 264.920	B	32
					300 4-matic (253.349)	M 274.920	BG	29
					300 4-matic (253.384)	M 264.920	B	32
					300 EQ Boost 4-matic (253.384)	M 264.920	B	32
					300 d 4-matic (253.319)	OM 654.920	D	27

		Pos			Pos		
300 de 4-matic (253.311) 05.2020 →	OM 654.920	D	27	220 CDI 4-matic 12.2008 → 06.2015	OM 651.912	D	36
300 de 4-matic (253.311) 05.2020 →	OM 654.920	D	27	(204.984, 204.997)			
300 e 4-matic (253.353) 11.2019 →	M 274.920	BG	29	250 (204.936) 08.2013 → 06.2015	M 274.920	BG	29
350 d 4-matic (253.325) 10.2016 → 04.2019	OM 642.873	D	44	250 4-matic (204.937) 08.2013 → 06.2015	M 274.920	BG	29
350 e 4-matic (253.354) 10.2016 → 04.2019	M 274.920	BG	29	250 CDI 4-matic 09.2012 → 06.2015	OM 651.912	D	36
350 e 4-matic (253.354) 10.2016 → 04.2019	M 274.920	BG	29	250 CDI 4-matic 09.2009 → 06.2015	OM 651.912	D	36
400 d 4-matic (253.323) 08.2019 →	OM 656.929	D	27	(204.982, 204.904)			
<b>GLE (V167)</b>				280 4-matic (204.981) 06.2008 → 06.2009	M 272.948	B	67
GLE 300 d 4-matic 10.2018 → 05.2021 (167.119)	OM 654.920	D	27	300 4-matic (204.981) 07.2009 → 12.2015	M 272.948	B	67
GLE 350 (167.148) 04.2019 →	M 264.920	B	32	300 4-matic (204.990) 09.2009 → 06.2015	M 276.957	B	113
GLE 350 4-matic (167.149) 04.2019 →	M 264.920	B	32	300 4-matic (204.990) 09.2009 → 12.2015	M 276.957	B	113
GLE 350 d 4-matic (167.121) 12.2018 → 05.2021	OM 656.929	D	27	320 CDI 4-matic (204.983) 06.2008 → 06.2015	OM 642.961	D	34
GLE 350 de 4-matic (167.117) 11.2019 →	OM 654.920	D	27	350 (204.956) 04.2009 → 06.2015	M 272.991	B	114
GLE 350 de 4-matic (167.117) 11.2019 →	OM 654.920	D	27	350 4-matic (204.987) 06.2008 → 04.2011	M 272.971	B	111
GLE 350 de 4-matic (167.117) 03.2020 →	OM 654.920	D	27	350 4-matic (204.988) 06.2008 → 06.2015	M 276.957	B	113
GLE 350 e 4-matic (167.154) 06.2020 →	M 274.920	BG	29	350 CDI 4-matic (204.992) 07.2009 → 01.2010	OM 642.832	D	34
GLE 350 e 4-matic (167.154) 06.2020 →	M 274.920	BG	29	350 CDI 4-matic (204.992) 02.2010 → 06.2015	OM 642.832	D	34
GLE 400 d 4-matic (167.123) 12.2018 →	OM 656.929	D	27	350 CDI 4-matic (204.993) 07.2012 → 06.2015	OM 642.835	D	34
<b>GLE (W166)</b>				350 CGI (204.957) 09.2012 → 06.2015	M 276.957	B	113
250 d (166.006) 04.2015 → 10.2018	OM 651.960	D	36	<b>GLS (X166)</b>			
250 d 4-matic (166.004) 04.2015 → 10.2018	OM 651.960	D	36	350 d 4-matic (166.824) 11.2015 → 04.2019	OM 642.826	D	34
350 (166.058) 11.2015 → 10.2018	M 276.955	B	113	350 d 4-matic (166.824) 01.2017 → 04.2019	OM 642.826	D	34
350 4-matic (166.057) 11.2015 → 10.2018	M 276.955	B	113	500 4-matic (166.873) 11.2015 → 04.2019	M 278.928	B	113
350 Flexfuel 4-matic (166.057) 11.2015 → 10.2018	M 276.955	B	113	<b>GLS (X167)</b>			
350 d 4-matic (166.024) 04.2015 → 10.2018	OM 642.826	D	34	350 d 4-matic (167.921) 04.2019 →	OM 656.929	D	27
350 d 4-matic (166.024) 04.2015 → 10.2018	OM 642.826	D	34	400 d 4-matic (167.923) 04.2019 →	OM 656.929	D	27
500 4-matic (166.073) 04.2015 → 10.2018	M 278.928	B	113	<b>HECKFLOSSE (W110)</b>			
500 4-matic (166.073) 04.2015 → 10.2018	M 278.928	B	113	190 C (110.010) 04.1961 → 08.1965	M 121.924	B	50
500 4-matic (166.073) 10.2015 → 10.2018	M 278.928	B	113	190 DC (110.110) 06.1961 → 08.1965	OM 621.912	D	59
<b>GLE Coupe (C167)</b>				200 07.1965 → 02.1968	M 115.926	B	58
GLE 350 4-matic (167.349) 09.2020 →	M 264.920	B	32	200 (110.010) 07.1965 → 02.1968	M 121.940	B	58
GLE 350 d 4-matic (167.321) 11.2019 → 05.2021	OM 656.929	D	27	200 D (110.110) 07.1965 → 02.1968	OM 621.918	D	59
GLE 350 de 4-matic (167.317) 03.2020 →	OM 654.920	D	27	230 06.1966 → 12.1967	M 180.950	B	16
GLE 350 de 4-matic (167.317) 03.2020 →	OM 654.920	D	27	230 (110.011) 07.1965 → 02.1968	M 180.945	B	16
GLE 350 e 4-matic (167.354) 06.2020 →	M 274.920	BG	29	230 (110.011) 07.1965 → 02.1968	M 180.949	B	16
GLE 350 e 4-matic (167.354) 06.2020 →	M 274.920	BG	29	<b>HECKFLOSSE (W111, W112)</b>			
GLE 400 d 4-matic (167.323) 11.2019 →	OM 656.929	D	27	220 B (111.010) 08.1959 → 08.1965	M 180.940	B	9
<b>GLE Coupe (C292)</b>				220 SB (111.012) 08.1959 → 07.1965	M 180.941	B	9
350 d 4-matic (292.323, 292.324) 03.2015 → 10.2019	OM 642.824	D	42	220 SEB (111.014) 08.1959 → 08.1965	M 127.982	B	9
350 d 4-matic (292.323, 292.324) 03.2015 → 10.2019	OM 642.826	D	34	230 S (111.010) 07.1965 → 01.1968	M 180.947	B	16
350 d 4-matic (292.324) 03.2016 → 10.2019	OM 642.826	D	34	230 S (111.010) 07.1965 → 01.1968	M 180.950	B	16
350 d 4-matic (292.324) 01.2017 → 10.2019	OM 642.826	D	34	<b>M-CLASS (W163)</b>			
500 4-matic (292.373) 10.2015 → 10.2019	M 278.928	B	113	ML 230 (163.136) 02.1998 → 06.2005	M 111.977	B	99
<b>GLK-CLASS (X204)</b>				ML 270 CDI (163.113) 12.1999 → 06.2005	OM 612.963	D	70
200 (204.934) 08.2013 → 06.2015	M 274.920	BG	29	ML 320 (163.154) 02.1998 → 08.2002	M 112.942	B	95
200 CDI (204.901) 07.2010 → 06.2015	OM 651.913	D	36	ML 350 02.2003 → 06.2005	M 112.970	B	127
200 CDI (204.901) 07.2010 → 06.2015	OM 651.916	D	36	ML 350 (163.157) 08.2002 → 06.2005	M 112.970	B	127
200 CDI (204.901) 12.2013 → 06.2015	OM 651.916	D	36	ML 400 CDI (163.128) 09.2001 → 06.2005	OM 628.963	D	56
220 CDI (204.902) 12.2008 → 06.2015	OM 651.916	D	36	ML 430 (163.172) 02.1998 → 06.2005	M 113.942	B	95
220 CDI (204.902) 12.2008 → 06.2015	OM 651.916	D	36	ML 500 (163.175) 09.2001 → 06.2005	M 113.964	B	127
220 CDI 4-matic (204.984) 12.2008 → 06.2015	OM 651.912	D	36	ML 500 (163.175) 09.2001 → 06.2005	M 113.965	B	127
				ML 55 AMG (163.174) 02.2000 → 06.2005	M 113.981	B	127
				<b>M-CLASS (W164)</b>			
				ML 280 CDI 4-matic (164.120) 07.2005 → 07.2009	OM 642.940	D	34
				ML 300 4-matic (164.182) 03.2010 → 12.2011	M 272.945	B	67
				ML 300 CDI 4-matic (164.121) 07.2009 → 12.2011	OM 642.940	D	34
				ML 300 CDI 4-matic (164.121) 02.2010 → 12.2011	OM 642.820	D	34
				ML 320 CDI 4-matic 09.2006 → 12.2008	OM 642.940	D	34
				ML 320 CDI 4-matic (164.122) 07.2005 → 07.2009	OM 642.940	D	34

M

		Pos			Pos
ML 320 CDI 4-matic (164.124, 164.125, 164.122) 07.2005 → 07.2011	OM 642.820 D	34	R 300 CDI (251.021, 251.121, 251.026, 251.126) 07.2009 → 12.2012	OM 642.870 D	34
ML 320 CDI 4-matic (164.124, 164.125, 164.122) 07.2005 → 07.2011	OM 642.940 D	34	R 300 CDI (251.021, 251.121, 251.026, 251.126) 07.2009 → 12.2012	OM 642.872 D	34
ML 350 (164.156) 01.2009 → 12.2011	M 272.967 B	111	R 300 CDI (251.021, 251.121, 251.026, 251.126) 07.2009 → 12.2012	OM 642.950 D	34
ML 350 4-matic (164.186) 02.2005 → 12.2011	M 272.967 B	111	R 300 CDI 4-matic (251.020) 07.2009 → 12.2012	OM 642.950 D	34
ML 350 CDI 4-matic 09.2009 → 12.2010	OM 642.820 D	34	R 320 CDI 4-matic 09.2006 → 12.2008	OM 642.950 D	34
ML 350 CDI 4-matic 09.2010 → 12.2011	OM 642.822 D	34	R 320 CDI 4-matic 09.2008 → 12.2009	OM 642.870 D	34
ML 350 CDI 4-matic (164.122) 07.2009 → 12.2011	OM 642.940 D	34	R 320 CDI 4-matic (251.022, 251.122) 01.2006 → 07.2010	OM 642.950 D	34
ML 350 CDI 4-matic (164.125, 164.124) 09.2009 → 12.2011	OM 642.820 D	34	R 320 CDI 4-matic (251.125) 01.2006 → 12.2012	OM 642.870 D	34
ML 350 CDI 4-matic (164.125, 164.124) 02.2010 → 12.2011	OM 642.820 D	34	R 320 CDI 4-matic (251.125) 01.2006 → 12.2012	OM 642.950 D	34
ML 420 CDI 4-matic (164.128) 02.2006 → 09.2009	OM 629.912 D	56	R 350 (251.056, 251.156) 01.2007 → 12.2012	M 272.967 B	111
ML 450 CDI 4-matic (164.128) 09.2009 → 12.2011	OM 629.912 D	56	R 350 4-matic (251.065, 251.165) 08.2005 → 12.2012	M 272.967 B	111
ML 500 4-matic (164.172) 12.2007 → 12.2011	M 273.963 B	237	R 350 CDI 4-matic (251.022, 251.122) 09.2009 → 12.2012	OM 642.870 D	34
ML 500 4-matic (164.175) 07.2005 → 12.2011	M 113.964 B	127	R 350 CDI 4-matic (251.023, 251.123) 08.2010 → 12.2014	OM 642.872 D	34
ML 500 4-matic (164.175) 09.2005 → 12.2006	M 113.964 B	127	R 350 CDI 4-matic (251.124, 251.125) 01.2006 → 12.2014	OM 642.870 D	34
<b>M-CLASS (W166)</b>					
ML 250 CDI / BlueTEC 4-matic (166.004, 166.003) 06.2011 → 12.2015	OM 651.960 D	36	R 350 CDI 4-matic (251.124, 251.125) 01.2006 → 12.2014	OM 642.950 D	34
ML 300 4-matic (166.055) 08.2012 → 02.2015	M 276.955 B	113	R 350 CGI 4-matic (251.057, 251.157) 10.2011 → 12.2014	M 276.958 B	113
ML 300 4-matic (166.055) 08.2012 → 02.2015	M 276.955 B	113	R 500 4-matic (251.072, 251.172) 01.2006 → 12.2006	M 113.971 B	127
ML 350 (166.058) 09.2011 → 02.2015	M 276.955 B	113	R 500 4-matic (251.075, 251.175) 05.2007 → 12.2014	M 273.963 B	237
ML 350 4-matic (166.057) 06.2011 → 12.2015	M 276.955 B	113	R 500 4-matic (251.075, 251.175) 08.2005 → 12.2014	M 113.960 B	127
ML 350 BlueTEC 4-matic (166.024) 06.2011 → 02.2015	OM 642.826 D	34	R 500 4-matic (251.075, 251.175) 08.2005 → 12.2014	M 113.971 B	127
ML 350 BlueTEC 4-matic (166.024) 06.2011 → 02.2015	OM 642.864 D	35	<b>S-CLASS (V223)</b>		
ML 350 CDI 4-matic (166.023) 09.2012 → 02.2014	OM 642.826 D	34	S 350 d (223.130) 09.2020 →	OM 656.929 D	27
ML 350 CDI 4-matic (166.023) 06.2011 → 02.2015	OM 642.940 D	34	S 350 d 4-matic (223.131) 09.2020 →	OM 656.929 D	27
ML 500 4-matic (166.073) 02.2012 → 02.2015	M 278.928 B	113	S 400 d 4-matic (223.133) 09.2020 →	OM 656.929 D	27
<b>PAGODE (W113)</b>					
230 SL (113.042) 01.1963 → 01.1967	M 127.981 B	19	280 S (116.020) 08.1972 → 07.1980	M 110.922 B	53
250 SL (113.043) 01.1966 → 01.1968	M 129.982 B	20	280 S (116.020) 08.1972 → 07.1980	M 110.922 B	53
280 SL (113.044) 01.1968 → 03.1971	M 130.983 B	57	280 SE,SEL (116.024) 08.1972 → 07.1980	M 110.983 B	53
<b>PONTON (W120)</b>					
180 (120.010) 07.1953 → 12.1962	M 136.925 B	49	280 SE,SEL (116.024) 08.1972 → 07.1980	M 110.985 B	53
180 D (120.110) 01.1953 → 07.1959	OM 636.930 D	5	350 SE,SEL (116.028, 116.029) 08.1972 → 02.1976	M 116.983 B	107
<b>PONTON (W128)</b>					
220 SE (128.010) 01.1958 → 08.1959	M 127.980 B	9	350 SE,SEL (116.028, 116.029) 03.1976 → 03.1980	M 116.985 B	107
<b>R-CLASS (W251, V251)</b>					
550 05.2007 →	M 273.963 B	237	350 SE,SEL (116.028, 116.029) 03.1976 → 03.1980	M 116.985 B	107
R 280 (251.054, 251.154) 01.2007 → 12.2014	M 272.945 B	67	450 SE 01.1973 → 12.1976	M 117.983 B	107
R 280 4-matic (251.062) 05.2007 → 12.2011	M 272.945 B	67	450 SE,SEL (116.032) 01.1973 → 04.1980	M 117.983 B	107
R 280 CDI (251.121, 251.026, 251.126) 05.2006 → 12.2012	OM 642.870 D	34	450 SE,SEL (116.032) 01.1973 → 04.1980	M 117.986 B	107
R 280 CDI (251.121, 251.026, 251.126) 05.2006 → 12.2012	OM 642.872 D	34	450 SE,SEL (116.033) 12.1975 → 04.1980	M 117.983 B	107
R 280 CDI (251.121, 251.026, 251.126) 05.2006 → 12.2012	OM 642.950 D	34	450 SE,SEL (116.033) 12.1975 → 04.1980	M 117.986 B	107
R 280 CDI 4-matic (251.020) 05.2006 → 12.2012	OM 642.950 D	34	450 SEL (116.033) 09.1979 → 07.1980	M 117.983 B	107
R 300 (251.054, 251.154) 07.2009 → 12.2014	M 272.945 B	67	<b>S-CLASS (W116)</b>		
R 300 (251.154) 01.2011 → 12.2014	M 272.945 B	67	260 SE (126.020) 09.1985 → 06.1991	M 103.941 B	28
R 300 4-matic (251.062) 07.2009 → 12.2011	M 272.945 B	67	260 SE (126.020) 09.1985 → 06.1991	M 103.941 B	28
			280 S (126.021) 12.1979 → 07.1985	M 110.924 B	54
			280 S (126.021) 12.1979 → 07.1985	M 110.926 B	54
			280 SE, SEL (126.022, 126.023) 10.1979 → 07.1985	M 110.987 B	54



			Pos				Pos
280 SE, SEL (126.022, 126.023)	10.1979 → 07.1985	M 110.989	B 54	S 400 CDI (220.028, 220.128)	06.2000 → 08.2005	OM 628.960	D 56
3.8	08.1980 → 08.1984	M 116.961	B 108	S 400 CDI (220.028, 220.128)	06.2003 → 08.2005	OM 628.960	D 56
300 SD (126.120)	09.1980 → 12.1985	OM 617.951	D 102	S 430 (220.070, 220.170)	10.1998 → 08.2005	M 113.941	B 95
300 SDL (126.125)	09.1985 → 12.1986	OM 603.961	D 62	S 430 4-matic (220.083, 220.183)	09.2002 → 08.2005	M 113.948	B 95
300 SE, SEL (126.024, 126.025)	09.1985 → 12.1989	M 103.981	B 76	S 500 (220.075, 220.175, 220.875)	10.1998 → 12.2003	M 113.960	B 127
300 SE, SEL (126.024, 126.025)	01.1986 → 06.1991	M 103.981	B 76	S 500 (220.075, 220.175, 220.875)	10.1998 → 08.2005	M 113.960	B 127
380 SE, SEL (126.032)	10.1981 → 08.1985	M 116.963	B 66	S 500 (220.075, 220.175, 220.875)	10.1998 → 08.2005	M 113.966	B 127
380 SE, SEL (126.032, 126.033)	09.1980 → 10.1981	M 116.961	B 108	S 500 4-matic (220.084, 220.184)	09.2002 → 08.2005	M 113.966	B 127
380 SE, SEL (126.032, 126.033)	01.1981 → 03.1986	M 116.963	B 66	S 55 AMG (220.073, 220.173)	04.1999 → 08.2005	M 113.986	B 127
420 SE, SEL	10.1985 → 12.1987	M 116.965	B 109	S 55 AMG Kompressor (220.074, 220.174)	06.2002 → 08.2005	M 113.991	B 127
420 SE, SEL	10.1985 → 06.1991	M 116.965	B 109	<b>S-CLASS (W221)</b>			
420 SE, SEL	10.1985 → 06.1991	M 116.965	B 109	S 250 CDI (221.003, 221.103)	01.2011 → 12.2013	OM 651.961	D 36
420 SE, SEL (126.034)	10.1985 → 12.1987	M 116.965	B 109	S 280 (221.054)	08.2006 → 12.2013	M 272.946	B 67
420 SE, SEL (126.034, 126.035)	10.1985 → 06.1991	M 116.965	B 109	S 300 (221.054, 221.154)	08.2006 → 12.2013	M 272.946	B 67
500 SE, SEL	09.1987 → 06.1991	M 117.965	B 123	S 300 (221.154)	04.2012 → 12.2013	M 272.946	B 67
500 SE, SEL	09.1987 → 06.1991	M 117.965	B 123	S 320 CDI	10.2005 → 12.2013	OM 642.930	D 34
500 SE, SEL (126.036)	12.1979 → 08.1985	M 117.961	B 122	S 320 CDI (221.022, 221.122)	12.2005 → 06.2009	OM 642.930	D 34
500 SE, SEL (126.036)	12.1979 → 08.1985	M 117.961	B 122	S 320 CDI 4-matic (221.080, 221.180)	10.2005 → 12.2013	OM 642.932	D 34
500 SE, SEL (126.036)	12.1979 → 08.1985	M 117.963	B 123	S 320 CDI 4-matic (221.080, 221.180)	10.2006 → 12.2013	OM 642.932	D 34
500 SE, SEL (126.036)	12.1979 → 08.1985	M 117.963	B 123	S 350 (221.056, 221.156)	10.2005 → 12.2013	M 272.965	B 111
500 SE, SEL (126.036)	09.1985 → 06.1991	M 117.965	B 123	S 350 4-matic (221.087, 221.187)	02.2008 → 12.2013	M 272.975	B 111
500 SE, SEL (126.036)	09.1985 → 06.1991	M 117.965	B 123	S 350 BlueTEC 4-matic (221.083, 221.183)	04.2011 → 12.2013	OM 642.868	D 34
500 SE, SEL Cat	06.1989 → 06.1991	M 117.965	B 123	S 350 BlueTEC (221.026, 221.126)	04.2011 → 12.2013	OM 642.862	D 34
560 SE, SEL	10.1985 → 06.1991	M 117.968	B 124	S 350 CDI	06.2009 → 12.2013	OM 642.930	D 34
560 SE, SEL	08.1987 → 06.1991	M 117.968	B 124	S 350 CDI	06.2009 → 12.2013	OM 642.930	D 34
560 SE, SEL (126.038)	10.1985 → 12.1987	M 117.968	B 124	S 350 CDI 4-matic (221.080, 221.081)	01.2009 → 12.2010	OM 642.932	D 34
560 SE, SEL (126.038, 126.039)	10.1985 → 06.1991	M 117.968	B 124	S 350 CDI 4-matic (221.080, 221.180)	06.2009 → 07.2013	OM 642.932	D 34
<b>S-CLASS (W140)</b>				S 350 CGI (221.057, 221.157)	04.2011 → 12.2013	M 276.950	B 113
300 SE 2.8 (140.028)	01.1993 → 10.1998	M 104.944	B 91	S 350 CGI 4-matic (221.082, 221.182)	04.2011 → 12.2013	M 276.950	B 113
300 SE, SEL/S320 (140.032, 140.033)	03.1991 → 10.1998	M 104.990	B 90	S 400 4-matic	09.2008 → 12.2009	M 273.924	B 111
300 SE, SEL/S320 (140.032, 140.033)	03.1991 → 10.1998	M 104.994	B 91	S 400 Hybrid (221.095, 221.195)	01.2009 → 12.2013	M 272.974	B 112
400	06.1993 → 09.1998	M 119.971	B 110	S 420 CDI (221.028, 221.128)	10.2006 → 12.2009	OM 629.911	D 56
400 SE, SEL/S420 (140.042, 140.043)	02.1991 → 10.1998	M 119.971	B 110	S 450 (221.070, 221.170)	12.2005 → 12.2013	M 273.922	B 111
500 SE, SEL (140.050, 140.051)	02.1991 → 10.1998	M 119.970	B 125	S 450 4-matic (221.084, 221.184)	12.2005 → 12.2013	M 273.924	B 111
600 SE, SEL (140.056, 140.057)	04.1991 → 12.1992	M 120.980	B 81	S 450 CDI (221.028, 221.128)	01.2009 → 12.2013	OM 629.911	D 56
600 SE, SEL (140.056, 140.057)	04.1991 → 12.1992	M 120.982	B 81	S 500	05.2011 → 12.2013	M 273.961	B 237
S 280 (140.028)	02.1993 → 10.1998	M 104.944	B 91	S 500 (221.071, 221.171)	10.2005 → 12.2013	M 273.961	B 237
S 300 Turbo-D (140.135)	05.1996 → 10.1998	OM 606.961	D 65	S 500 4-matic (221.086, 221.186)	10.2005 → 12.2013	M 273.961	B 237
S 320	10.1995 → 08.1998	M 104.990	B 90	S 500 4-matic (221.086, 221.186)	10.2005 → 12.2013	M 273.968	B 237
S 350 Turbo-D (140.134)	01.1993 → 10.1998	OM 603.971	D 84	S 500 CGI (221.073, 221.173)	04.2011 → 12.2013	M 278.932	B 115
S 420	02.1991 → 10.1998	M 119.971	B 110	S 500 CGI 4-matic (221.094, 221.194)	03.2011 → 12.2013	M 278.932	B 115
S 420 (140.042)	01.1993 → 10.1998	M 119.971	B 110	S 550 (221.073, 221.173)	09.2011 → 12.2013	M 278.932	B 115
S 500 (140.050, 140.051)	01.1993 → 10.1998	M 119.970	B 125	S 550 4-matic (221.094, 221.194)	09.2011 → 12.2013	M 278.932	B 115
S 500 (140.050, 140.051)	01.1993 → 10.1998	M 119.980	B 125				
S 600 (140.056, 140.057)	01.1993 → 10.1998	M 120.980	B 81				
S 600 (140.056, 140.057)	01.1993 → 10.1998	M 120.982	B 81				
<b>S-CLASS (W220)</b>							
370	09.2002 → 08.2005	M 112.972	B 127				
S 280 (220.063, 220.163)	10.1998 → 08.2005	M 112.922	B 95				
S 320 (220.065, 220.165)	10.1998 → 08.2005	M 112.944	B 95				
S 320 CDI (220.025, 220.125)	09.2002 → 08.2005	OM 648.960	D 72				
S 320 CDI (220.026, 220.126)	08.1999 → 09.2002	OM 613.960	D 70				
S 350 (220.067, 220.167)	09.2002 → 08.2005	M 112.972	B 127				
S 350 4-matic (220.087, 220.187)	06.2003 → 08.2005	M 112.975	B 127				

M

		Pos			Pos
S 63 AMG (221.074, 221.174)	03.2011 → 12.2013	M 157.980 B	<b>237</b>	<b>S-CLASS Coupe (C140)</b>	
S 63 AMG (221.074, 221.174)	02.2012 → 12.2013	M 157.980 B	<b>237</b>	500 SEC / CL 500 (140.070)	10.1992 → 12.1999 M 119.970 B <b>125</b>
<b>S-CLASS (W222, V222, X222)</b>				500 SEC / CL 500 (140.070)	10.1992 → 12.1999 M 119.980 B <b>125</b>
S 300 BlueTEC Hybrid / h (222.004, 222.104)	02.2014 → 05.2017	OM 651.921 D	<b>39</b>	CL 600	09.1996 → 12.1997 M 120.982 B <b>81</b>
S 300 BlueTEC Hybrid / h (222.104)	02.2014 → 05.2017	OM 651.921 D	<b>39</b>	SEC/CL 420 (140.063)	10.1994 → 02.1999 M 119.971 B <b>110</b>
S 320 L EQ Boost (222.150)	08.2018 →	M 264.920 B	<b>32</b>	SEC/CL 420 (140.063)	10.1994 → 02.1999 M 119.981 B <b>110</b>
S 350 BlueTEC / d (222.132, 222.032, 222.123)	05.2013 → 05.2017	OM 642.861 D	<b>34</b>	SEC/CL 600	07.1992 → 05.1993 M 120.980 B <b>81</b>
S 350 BlueTEC / d 4-matic (222.033, 222.133)	02.2014 → 05.2017	OM 642.861 D	<b>34</b>	SEC/CL 600 (140.076)	09.1992 → 02.1999 M 120.980 B <b>81</b>
S 350 BlueTEC / d 4-matic (222.033, 222.133)	02.2014 → 05.2017	OM 642.867 D	<b>40</b>	SEC/CL 600 (140.076)	09.1992 → 02.1999 M 120.982 B <b>81</b>
S 350 BlueTEC 4-matic (222.133)	02.2014 → 05.2017	OM 642.867 D	<b>40</b>	<b>S-CLASS Coupe (C215)</b>	
S 350 d (222.020, 222.120)	07.2017 →	OM 656.929 D	<b>27</b>	CL 500 (215.375)	03.1999 → 03.2006 M 113.960 B <b>127</b>
S 350 d 4-matic (222.021, 222.121)	05.2017 →	OM 656.929 D	<b>27</b>	CL 500 (215.375)	09.2004 → 12.2005 M 113.960 B <b>127</b>
S 350 d 4-matic (222.121)	07.2018 →	OM 656.929 D	<b>27</b>	CL 55 AMG	09.2003 → 12.2005 M 113.991 B <b>127</b>
S 400 d (222.034, 222.134)	07.2017 →	OM 656.929 D	<b>27</b>	CL 55 AMG	09.2003 → 08.2006 M 113.991 B <b>127</b>
S 400 d 4-matic (222.035, 222.135)	05.2017 →	OM 656.929 D	<b>27</b>	CL 55 AMG (215.373)	10.1999 → 03.2006 M 113.986 B <b>127</b>
S 500 (222.082, 222.182)	05.2013 → 05.2017	M 278.929 B	<b>116</b>	CL 55 AMG Kompressor (215.374)	06.2002 → 03.2006 M 113.991 B <b>127</b>
S 500 (222.082, 222.182)	09.2013 → 05.2017	M 278.929 B	<b>116</b>	<b>S-CLASS Coupe (C216)</b>	
S 500 4-matic (222.085, 222.185)	05.2013 → 05.2017	M 278.929 B	<b>116</b>	CL 500 (216.371)	06.2006 → 12.2013 M 273.961 B <b>237</b>
S 500 4-matic (222.185)	09.2013 → 05.2017	M 278.929 B	<b>116</b>	CL 500 (216.373)	02.2011 → 12.2013 M 278.920 B <b>115</b>
S 500 Maybach (222.982)	12.2014 → 05.2017	M 278.929 B	<b>116</b>	CL 500 4-matic (216.386)	02.2008 → 12.2013 M 273.968 B <b>237</b>
S 500 Maybach (222.982)	12.2014 → 05.2017	M 278.929 B	<b>116</b>	CL 500 4-matic (216.394)	02.2011 → 12.2013 M 278.920 B <b>115</b>
S 500 Maybach 4-matic (222.985)	04.2015 → 05.2017	M 278.929 B	<b>116</b>	CL 63 AMG (216.374)	01.2010 → 12.2013 M 157.980 B <b>237</b>
<b>S-CLASS (W223)</b>				CL 63 AMG (216.374)	02.2011 → 12.2013 M 157.980 B <b>237</b>
S 350 d (223.030)	09.2020 →	OM 656.929 D	<b>27</b>	<b>S-CLASS Coupe (C217)</b>	
S 350 d 4-matic (223.031)	09.2020 →	OM 656.929 D	<b>27</b>	S 500 (217.382)	11.2014 → 10.2017 M 278.929 B <b>116</b>
S 400 d 4-matic (223.033)	09.2020 →	OM 656.929 D	<b>27</b>	S 500 4-matic (217.385)	04.2014 → 10.2017 M 278.929 B <b>116</b>
<b>S-CLASS Convertible (A217)</b>				<b>S-CLASS Saloon (W108, W109)</b>	
S 500 (217.482)	12.2015 → 10.2017	M 278.929 B	<b>116</b>	250 S (108.012)	01.1966 → 12.1969 M 108.920 B <b>20</b>
<b>S-CLASS Coupe (C126)</b>				250 SE (108.014)	01.1966 → 12.1967 M 129.980 B <b>20</b>
380 SEC (126.043)	08.1980 → 12.1981	M 116.961 B	<b>108</b>	280 S (108.016)	10.1967 → 07.1972 M 130.920 B <b>57</b>
380 SEC (126.043)	10.1981 → 07.1985	M 116.963 B	<b>66</b>	280 SE 4.5 (108.067)	09.1971 → 08.1972 M 117.984 B <b>107</b>
380 SEC (126.043)	02.1982 → 12.1985	M 116.963 B	<b>66</b>	280 SE,SEL (108.018, 108.019)	01.1968 → 08.1972 M 130.980 B <b>57</b>
420 SEC (126.046)	10.1985 → 12.1987	M 116.965 B	<b>109</b>	280 SE,SEL 3.5 (108.057, 108.058)	03.1971 → 08.1972 M 116.980 B <b>107</b>
420 SEC (126.046)	10.1985 → 06.1991	M 116.965 B	<b>109</b>	280 SEL 4.5 (108.068)	09.1971 → 08.1972 M 117.984 B <b>107</b>
420 SEC (126.046)	10.1985 → 06.1991	M 116.965 B	<b>109</b>	300 SEL (109.016)	01.1968 → 08.1972 M 130.981 B <b>57</b>
420 SEC (126.046)	09.1986 → 06.1991	M 116.965 B	<b>109</b>	300 SEL 3.5 (109.056)	01.1970 → 07.1972 M 116.981 B <b>107</b>
500 SEC (126.044)	08.1980 → 08.1985	M 117.963 B	<b>123</b>	<b>SL (R107)</b>	
500 SEC (126.044)	10.1981 → 08.1985	M 117.963 B	<b>123</b>	280 SL (107.042)	08.1974 → 07.1985 M 110.982 B <b>53</b>
500 SEC (126.044)	09.1985 → 06.1991	M 117.965 B	<b>123</b>	280 SL (107.042)	08.1974 → 07.1985 M 110.986 B <b>53</b>
500 SEC (126.044)	09.1985 → 06.1991	M 117.965 B	<b>123</b>	280 SL (107.042)	08.1974 → 07.1985 M 110.990 B <b>54</b>
500 SEC (126.044)	09.1985 → 06.1991	M 117.965 B	<b>123</b>	280 SL (107.042)	06.1976 → 09.1981 M 110.982 B <b>53</b>
500 SEC (126.044)	10.1985 → 06.1991	M 117.965 B	<b>123</b>	280 SL (107.042)	06.1976 → 09.1981 M 110.986 B <b>53</b>
500 SEC (126.044)	08.1987 → 06.1991	M 117.965 B	<b>123</b>	280 SL (107.042)	06.1976 → 09.1981 M 110.990 B <b>54</b>
500 SEC Cat	06.1989 → 06.1991	M 117.965 B	<b>123</b>	300 SL (107.041)	09.1985 → 08.1989 M 103.982 B <b>76</b>
560 SEC (126.045)	10.1985 → 12.1987	M 117.968 B	<b>124</b>	300 SL (107.041)	09.1985 → 08.1989 M 103.982 B <b>76</b>
560 SEC (126.045)	10.1985 → 12.1989	M 117.968 B	<b>124</b>	350 SL (107.043)	05.1971 → 12.1976 M 116.982 B <b>107</b>
560 SEC (126.045)	10.1985 → 06.1991	M 117.968 B	<b>124</b>	350 SL (107.043)	05.1971 → 02.1980 M 116.982 B <b>107</b>
560 SEC (126.045)	10.1985 → 06.1991	M 117.968 B	<b>124</b>	350 SL (107.043)	05.1971 → 02.1980 M 116.984 B <b>107</b>
560 SEC (126.045)	10.1985 → 06.1991	M 117.968 B	<b>124</b>	380 SL (107.045)	09.1980 → 08.1981 M 116.960 B <b>108</b>
560 SEC (126.045)	10.1985 → 06.1991	M 117.968 B	<b>124</b>	380 SL (107.045)	09.1980 → 08.1985 M 116.962 B <b>66</b>
560 SEC (126.045)	10.1985 → 06.1991	M 117.968 B	<b>124</b>	420 SL (107.047)	01.1986 → 08.1989 M 116.964 B <b>109</b>
560 SEC (126.045)	10.1985 → 06.1991	M 117.968 B	<b>124</b>	420 SL (107.047)	01.1986 → 08.1989 M 116.964 B <b>109</b>
560 SEC (126.045)	10.1985 → 06.1991	M 117.968 B	<b>124</b>	450 SL (107.044)	10.1972 → 10.1980 M 117.982 B <b>107</b>
560 SEC (126.045)	10.1985 → 06.1991	M 117.968 B	<b>124</b>	450 SL (107.044)	10.1972 → 10.1980 M 117.985 B <b>107</b>
560 SEC (126.045)	10.1985 → 06.1991	M 117.968 B	<b>124</b>	450 SL (107.044)	09.1975 → 10.1980 M 117.982 B <b>107</b>
560 SEC (126.045)	10.1985 → 06.1991	M 117.968 B	<b>124</b>	450 SL (107.044)	09.1975 → 10.1980 M 117.985 B <b>107</b>
560 SEC (126.045)	10.1985 → 06.1991	M 117.968 B	<b>124</b>	450 SL (107.044)	09.1979 → 12.1980 M 117.985 B <b>107</b>
560 SEC (126.045)	10.1985 → 06.1991	M 117.968 B	<b>124</b>	500 SL (107.046)	05.1980 → 12.1981 M 117.960 B <b>122</b>
560 SEC (126.045)	10.1985 → 06.1991	M 117.968 B	<b>124</b>	500 SL (107.046)	05.1980 → 12.1985 M 117.960 B <b>122</b>
560 SEC (126.045)	10.1985 → 06.1991	M 117.968 B	<b>124</b>	500 SL (107.046)	05.1980 → 12.1985 M 117.962 B <b>123</b>
560 SEC (126.045)	10.1985 → 06.1991	M 117.968 B	<b>124</b>	500 SL (107.046)	01.1986 → 08.1989 M 117.960 B <b>122</b>
560 SEC (126.045)	10.1985 → 06.1991	M 117.968 B	<b>124</b>	500 SL (107.046)	01.1986 → 08.1989 M 117.964 B <b>123</b>
560 SEC (126.045)	10.1985 → 06.1991	M 117.968 B	<b>124</b>	500 SL (107.046)	01.1986 → 08.1989 M 117.964 B <b>123</b>



			Pos				Pos		
560 SL	01.1986 → 12.1989	M 117.967	B	124	200 Kompressor	03.2000 → 04.2004	M 111.958	B	96
560 SL (107.048)	09.1985 → 12.1989	M 117.967	B	124	(170.444)				
<b>SL (R129)</b>					200 Kompressor	10.1996 → 03.2000	M 111.943	B	94
280 (129.058)	08.1993 → 10.2001	M 104.943	B	91	(170.445)				
280 (129.059)	05.1998 → 10.2001	M 112.923	B	95	230 (170.449)	09.2000 → 04.2004	M 111.983	B	101
300 SL (129.060)	03.1989 → 08.1993	M 103.984	B	76	230 Kompressor	09.1996 → 03.2000	M 111.973	B	99
300 SL-24 (129.061)	03.1989 → 07.1993	M 104.981	B	77	(170.447)				
320 (129.063)	09.1993 → 10.2001	M 104.991	B	91	230 Kompressor	09.1997 → 12.2000	M 111.973	B	99
320 (129.064)	05.1998 → 10.2001	M 112.943	B	95	(170.447)				
500 (129.067)	09.1992 → 10.2001	M 119.972	B	125	230 Kompressor	03.2000 → 04.2004	M 111.983	B	101
500 (129.067)	09.1992 → 10.2001	M 119.982	B	125	(170.449)				
500 (129.068)	05.1998 → 10.2001	M 113.961	B	127	32 AMG Kompressor	03.2001 → 04.2004	M 112.960	B	95
500 SL (129.066)	09.1989 → 08.1992	M 119.960	B	125	(170.466)				
500 SL (129.066)	09.1989 → 08.1992	M 119.972	B	125	320 (170.465)	03.2000 → 04.2004	M 112.947	B	95
55 AMG	08.1999 → 07.2001	M 113.992	B	127	<b>SLK (R171)</b>				
600 (129.076)	07.1992 → 10.2001	M 120.981	B	81	200 Kompressor	03.2004 → 02.2011	M 271.944	B	21
600 (129.076)	07.1992 → 10.2001	M 120.983	B	81	(171.442)				
600 SL (129.076)	02.1992 → 08.1994	M 120.981	B	81	200 Kompressor	01.2008 → 02.2011	M 271.954	B	23
600 SL (129.076)	02.1992 → 08.1994	M 120.983	B	81	(171.445)				
SL 320 (129.063)	09.1994 → 12.1997	M 104.991	B	91	280 (171.454)	01.2005 → 02.2011	M 272.942	B	67
<b>SL (R230)</b>					300 (171.454)	04.2009 → 02.2011	M 272.942	B	67
280 (230.454)	03.2008 → 01.2012	M 272.949	B	67	350 (171.456)	06.2004 → 02.2011	M 272.963	B	111
300 (230.454)	04.2009 → 01.2012	M 272.949	B	67	350 (171.458)	01.2008 → 02.2011	M 272.969	B	112
350 (230.456)	03.2006 → 01.2012	M 272.966	B	111	55 AMG (171.473)	06.2004 → 02.2011	M 113.989	B	127
350 (230.458)	04.2008 → 01.2012	M 272.968	B	112	55 AMG (171.473)	06.2006 → 02.2011	M 113.989	B	127
350 (230.467)	03.2003 → 01.2012	M 112.973	B	127	55 AMG (171.473)	09.2009 → 12.2011	M 113.989	B	127
500	09.2002 → 12.2005	M 113.963	B	127	<b>SLK (R172)</b>				
500 (230.471)	03.2006 → 01.2012	M 273.965	B	237	200 (172.434)	04.2015 →	M 274.920	BG	29
500 (230.475)	10.2001 → 01.2012	M 113.963	B	127	200 (172.448)	02.2011 →	M 271.860	B	24
55 AMG (230.472)	03.2006 → 01.2012	M 113.995	B	127	200 (172.448)	02.2011 →	M 271.861	B	24
55 AMG (230.474)	10.2001 → 06.2002	M 113.992	B	127	250 (172.447)	02.2011 →	M 271.860	B	24
55 AMG (230.474)	09.2003 → 12.2005	M 113.992	B	127	250 (172.447)	02.2011 →	M 271.861	B	24
55 AMG Kompressor (230.474)	06.2002 → 01.2012	M 113.992	B	127	250 CDI / d (172.403)	01.2012 →	OM 651.980	D	36
550	01.2006 → 01.2012	M 273.965	B	237	300 (172.438)	07.2015 →	M 274.920	BG	29
<b>SL (R231)</b>					350 (172.457)	02.2011 →	M 276.956	B	113
500 (231.473)	01.2012 →	M 278.927	B	115	<b>VANEO (414)</b>				
500 (231.473)	04.2015 →	M 278.927	B	115	1.6 (414.700)	02.2002 → 07.2005	M 166.961	B	11
550	01.2012 →	M 278.927	B	115	1.6 (414.700)	02.2002 → 07.2005	M 166.961	B	11
63 AMG (231.474)	01.2012 →	M 157.983	B	237	1.7 CDI (414.700)	02.2002 → 07.2005	OM 668.914	D	12
63 AMG (231.474)	01.2012 →	M 157.983	B	237	1.7 CDI (414.700)	02.2002 → 07.2005	OM 668.914	D	12
63 AMG (231.474)	04.2014 →	M 157.983	B	237	1.9 (414.700)	02.2002 → 07.2005	M 166.991	B	48
63 AMG (231.474)	07.2018 →	M 157.983	B	237	<b>X-CLASS (470)</b>				
<b>SL Coupe (C107)</b>					X 350 d 4-matic (470.252)	07.2018 → 05.2020	OM 642.889	D	46
280 SLC (107.022)	08.1974 → 09.1981	M 110.982	B	53					
280 SLC (107.022)	08.1974 → 09.1981	M 110.986	B	53	<b>2T-SERIES</b>				
280 SLC (107.022)	08.1974 → 09.1981	M 110.990	B	54	206 D 2.0	01.1971 → 02.1973	OM 615.915	D	59
280 SLC (107.022)	06.1976 → 09.1981	M 110.982	B	53	206 D 2.0	12.1976 → 07.1977	OM 615.943	D	59
280 SLC (107.022)	06.1976 → 09.1981	M 110.986	B	53	207 D 2.0	08.1977 → 01.1989	OM 615.944	D	59
280 SLC (107.022)	06.1976 → 09.1981	M 110.990	B	54	209 D 2.9	01.1994 →	OM 602.940	D	82
350 SLC (107.023)	01.1972 → 02.1976	M 116.982	B	107	210 D 3.0	09.1982 → 01.1989	OM 617.913	D	102
350 SLC (107.023)	01.1972 → 02.1976	M 116.984	B	107	<b>3T-SERIES</b>				
350 SLC (107.023)	03.1976 → 02.1980	M 116.982	B	107	306 D 2.0	01.1971 → 02.1973	OM 615.915	D	59
350 SLC (107.023)	03.1976 → 02.1980	M 116.984	B	107	306 D 2.2	03.1973 → 07.1977	OM 615.937	D	59
380 SLC (107.025)	07.1980 → 08.1981	M 116.960	B	108	306 D 2.2	03.1973 → 07.1977	OM 615.939	D	59
450 SLC (107.024)	01.1973 → 11.1975	M 117.982	B	107	307 D 2.0	08.1977 → 10.1985	OM 615.944	D	59
450 SLC (107.024)	01.1973 → 11.1975	M 117.985	B	107	307 D 2.3	10.1988 → 06.1995	OM 601.940	D	83
450 SLC (107.024)	09.1975 → 08.1979	M 117.982	B	107	308 2.3	05.1977 → 08.1982	M 115.972	B	117
450 SLC (107.024)	09.1975 → 08.1979	M 117.985	B	107	308 2.3	08.1982 → 06.1995	M 102.942	B	118
450 SLC (107.024)	09.1979 → 12.1980	M 117.985	B	107	308 2.3	01.1989 → 06.1995	M 102.945	B	119
450 SLC 5.0 (107.026)	06.1978 → 02.1980	M 117.960	B	122	308 D 2.4	05.1977 → 08.1982	OM 616.934	D	106
<b>SLC (R172)</b>					308 D 2.4	05.1977 → 08.1982	OM 616.939	D	102
180 (172.431)	01.2016 →	M 274.910	B	31	309 D 2.9		OM 602.940	D	82
200 (172.434)	01.2016 →	M 274.920	BG	29	319 1.9	01.1955 → 1961	M 121.922	B	51
250 d (172.404)	01.2016 → 10.2017	OM 651.980	D	36	319 1.9	06.1961 → 08.1965	M 121.926	B	51
260 (172.435)	05.2018 →	M 274.920	BG	29	319 1.9	06.1961 → 08.1965	M 121.929	B	51
300 (172.438)	01.2016 →	M 274.920	BG	29	319 2.0	08.1965 → 02.1968	M 121.941	B	58
<b>SLK (R170)</b>					319 2.0	08.1965 → 02.1968	M 121.942	B	58
200 (170.435)	09.1996 → 03.2000	M 111.946	B	93	319 D	08.1961 → 08.1966	OM 621.913	D	59

M

		Pos			Pos	
319 D	08.1961 → 12.1966	OM 621.915 D	59	111 CDI (415.603, 06.2013 → 415.605)	OM 607.951 D	6
319 D	08.1961 → 12.1966	OM 621.919 D	59	111 CDI (415.603, 05.2019 → 415.605)	OM 608.915 D	7
319 D	08.1961 → 12.1966	OM 621.930 D	59	112 (415.603) 06.2013 →	M 200.711 B	1
323	07.1964 → 02.1970	OM 352.910 D	129	<b>CITAN Mixto (Double Cabin) (W415)</b>		
323	1974 → 1982	OM 352.932 D	129	109 CDI 11.2012 →	OM 607.951 D	6
323	1974 → 1982	OM 352.933 D	129	111 CDI (415.601, 06.2013 → 415.603, 415.605)	OM 607.951 D	6
323	1974 → 1982	OM 352.942 D	129	<b>E-CLASS Platform/Chassis (VF210)</b>		
323	1974 → 1982	OM 352.972 D	129	E 220 CDi (210.606) 07.1999 → 12.2002	OM 611.961 D	68
323	1974 → 1982	OM 352.973 D	129	E 250 d (210.610) 06.1996 → 06.1998	OM 605.912 D	65
327	01.1964 → 1970	OM 352.901 D	129	E 270 CDI (210.616) 07.1999 → 12.2002	OM 612.961 D	70
327	01.1964 → 1970	OM 352.912 D	129	E 280 (210.663) 07.1999 → 11.2002	M 112.921 B	95
327	01.1964 → 1970	OM 352.930 D	129	E 290 TD (210.617) 07.1996 → 07.1999	OM 602.982 D	85
327	01.1964 → 1981	OM 352.931 D	129	<b>E-CLASS Platform/Chassis (VF211)</b>		
327	01.1964 → 1982	OM 352.978 D	129	E 220 CDI (211.606) 10.2003 → 07.2006	OM 646.961 D	73
327	1971 → 1982	OM 352.913 D	133	E 220 CDI (211.608) 04.2006 → 07.2009	OM 646.821 D	72
327	1971 → 1982	OM 352.946 D	133	E 270 CDI (211.616) 03.2003 → 07.2009	OM 647.961 D	72
327	1974 → 1981	OM 352.945 D	129	E 270 CDI (211.616) 10.2003 → 07.2005	OM 647.961 D	72
327	1974 → 1982	OM 352.976 D	129	E 280 CDI (211.620) 08.2005 → 07.2009	OM 642.920 D	34
328	01.1964 → 1970	OM 352.912 D	129	<b>HENSCHEL 2-t</b>		
328	1974 → 1982	OM 352.911 D	129	206 D 2.2 03.1973 → 07.1977	OM 615.917 D	59
328	1974 → 1982	OM 352.943 D	129	206 D 2.2 03.1973 → 07.1977	OM 615.937 D	59
328	1974 → 1982	OM 352.944 D	129	206 D 2.2 03.1973 → 07.1977	OM 615.939 D	59
328	1974 → 1982	OM 352.974 D	129	<b>MARCO POLO Camper (W447)</b>		
328	1974 → 1982	OM 352.975 D	129	160 CDI (447.703) 03.2015 →	OM 622.951 D	13
<b>4T-SERIES</b>				180 CDI (447.703) 03.2015 →	OM 622.951 D	13
405 D 2.0	09.1963 → 08.1965	OM 621.913 D	59	200 CDI (447.703, 03.2015 → 447.813)	OM 651.950 D	41
405 D 2.0	09.1963 → 08.1965	OM 621.915 D	59	200 CDI (447.703, 03.2019 → 447.813)	OM 654.920 D	27
405 D 2.0	09.1963 → 08.1965	OM 621.919 D	59	200 CDI 4-matic (447.703, 447.813) 03.2015 →	OM 651.950 D	41
405 D 2.0	09.1963 → 08.1965	OM 621.930 D	59	200 CDI 4-matic (447.703, 447.813) 03.2019 →	OM 654.920 D	27
406 2.0	08.1965 → 02.1968	M 121.943 B	58	220 CDI (447.703, 03.2015 → 447.813)	OM 651.950 D	41
406 2.0	08.1965 → 02.1968	M 121.944 B	58	220 CDI (447.703, 03.2019 → 447.813)	OM 654.920 D	27
406 D 2.0	09.1965 → 12.1966	OM 615.960 D	59	250 CDI (447.703, 03.2015 → 447.813)	OM 651.950 D	41
406 D 2.0	09.1965 → 12.1966	OM 621.913 D	59	250 CDI (447.703, 03.2019 → 447.813)	OM 654.920 D	27
406 D 2.0	09.1965 → 12.1966	OM 621.915 D	59	250 CDI 4-matic (447.703, 447.813) 03.2015 →	OM 651.950 D	41
406 D 2.0	09.1965 → 12.1966	OM 621.919 D	59	250 CDI (447.703, 03.2019 → 447.813)	OM 654.920 D	27
406 D 2.0	09.1965 → 12.1966	OM 621.919 D	59	250 CDI 4-matic (447.703, 447.813) 03.2015 →	OM 651.950 D	41
406 D 2.0	09.1965 → 12.1966	OM 621.930 D	59	250 CDI (447.703, 03.2019 → 447.813)	OM 654.920 D	27
406 D 2.0	09.1965 → 12.1966	OM 621.932 D	59	250 CDI 4-matic (447.703, 447.813) 03.2015 →	OM 651.950 D	41
406 D 2.4	01.1975 → 12.1988	OM 616.910 D	106	250 CDI 4-matic (447.703, 447.813) 03.2019 →	OM 654.920 D	27
406 D 2.4	12.1980 → 06.1989	OM 616.960 D	102	250 CDI 4-matic (447.703, 447.813) 03.2019 →	OM 651.950 D	41
407 1.9	01.1955 → 1961	M 121.922 B	51	300 CDI (447.813, 03.2019 → 12.2020 447.703)	OM 654.920 D	27
407 1.9	06.1961 → 08.1965	M 121.926 B	51	300 CDI (447813, 01.2021 → 447703)	OM 654.920 D	27
407 1.9	06.1961 → 08.1965	M 121.929 B	51	300 CDI 4-matic (447.813, 447.703) 03.2019 → 12.2020	OM 654.920 D	27
407 1.9	06.1961 → 08.1965	M 121.929 B	51	300 CDI 4-matic (447813, 447703) 01.2021 →	OM 654.920 D	27
407 2.0	08.1965 → 02.1968	M 121.941 B	58	<b>MB</b>		
407 2.0	08.1965 → 02.1968	M 121.942 B	58	100 2.0 D 12.1980 → 06.1989	OM 615.963 D	59
407 2.0	08.1965 → 02.1968	M 121.942 B	58	100 2.0 D 12.1980 → 06.1989	OM 615.970 D	59
407 2.0	08.1965 → 02.1968	M 121.944 B	58	100 2.0 D 05.1986 → 06.1989	OM 615.917 D	59
407 D 2.0	09.1965 → 12.1966	OM 621.932 D	59	100 2.3 11.1996 →	4-390 D	250
407 D 2.2	01.1968 → 12.1974	OM 615.910 D	59	100 2.3 D 01.1996 →	OM 661.911 D	87
407 D 2.2	03.1973 → 07.1977	OM 615.938 D	59	100 2.9 D 01.1996 →	OM 662.911 D	88
408 1.9	01.1955 → 1961	M 121.922 B	51	120 2.4 D 01.1987 → 12.1990	OM 616.963 D	102
408 1.9	06.1961 → 08.1965	M 121.926 B	51	130 2.4 D 12.1980 → 09.1983	OM 616.961 D	106
408 1.9	06.1961 → 08.1965	M 121.929 B	51	140 2.4 D 10.1983 → 12.1986	OM 616.961 D	106
408 2.0	08.1965 → 02.1968	M 121.941 B	58	140 2.4 D 01.1987 → 06.1990	OM 616.963 D	102
408 2.0	08.1965 → 02.1968	M 121.941 B	58	<b>CITAN Box Body/MPV (W415)</b>		
408 2.0	08.1965 → 02.1968	M 121.942 B	58	108 CDI (415.601, 11.2012 → 415.603)	OM 607.951 D	6
408 2.0	08.1965 → 02.1968	M 121.942 B	58	108 CDI (415.603) 05.2019 →	OM 608.915 D	7
408 2.0	08.1965 → 02.1968	M 121.943 B	58	109 CDI (415.601, 11.2012 → 415.603, 415.605)	OM 607.951 D	6
408 2.0	08.1965 → 02.1968	M 121.944 B	58	109 CDI (415.603, 05.2019 → 415.605)	OM 608.915 D	7
409 2.2	01.1968 → 12.1974	M 115.921 B	58			
409 2.2	01.1968 → 12.1974	M 115.927 B	58			
409 2.2	01.1968 → 12.1974	M 115.928 B	58			
410 2.2	01.1968 → 12.1974	M 115.921 B	58			
410 2.2	01.1968 → 12.1974	M 115.927 B	58			
410 2.2	01.1968 → 12.1974	M 115.928 B	58			

M

			Pos				Pos		
150 2.4 D	10.1983 → 12.1986	OM 616.961	D	106	214 NGT	02.1995 → 05.2006	M 111.979	BG	98
160 2.4 D	01.1987 → 06.1990	OM 616.963	D	102	214 NGT	02.1995 → 05.2006	M 111.984	BG	98
180 2.4 D	10.1983 → 12.1986	OM 616.961	D	106	216 CDI	04.2000 → 05.2006	OM 612.981	D	71
180 2.4 D	10.1983 → 01.1996	OM 616.910	D	106	<b>SPRINTER 2-t Van (B901, B902)</b>				
180 2.4 D	10.1983 → 01.1996	OM 616.963	D	102	208 CDI	04.2000 → 05.2006	OM 611.987	D	69
500		OM 384.906	D	201	208 D	02.1995 → 04.2000	OM 601.943	D	83
70 2.4 D	12.1980 → 09.1983	OM 616.961	D	106	208 D	10.1996 → 04.2000	OM 601.943	D	83
700	06.1985 →	OM 384.906	D	201	210 D	01.1997 → 04.2000	OM 602.980	D	85
700	06.1985 →	OM 384.907	D	217	211 CDI	04.2000 → 05.2006	OM 611.981	D	69
800	06.1985 →	OM 304.900-410	D	211	212 D	02.1995 → 04.2000	OM 602.980	D	85
800	06.1985 →	OM 384.907	D	217	213 CDI	04.2000 → 05.2006	OM 611.981	D	69
800	12.1993 →	OM 384.908	D	212	214	02.1995 → 05.2006	M 111.979	BG	98
90 2.0 D	03.1985 → 12.1986	OM 615.963	D	59	214	02.1995 → 05.2006	M 111.984	BG	98
90 2.0 D	03.1985 → 12.1986	OM 615.970	D	59	214 NGT	02.1995 → 05.2006	M 111.979	BG	98
<b>MB Bus (W631)</b>					214 NGT	02.1995 → 05.2006	M 111.984	BG	98
2.0 D	04.1988 → 08.1993	OM 615.963	D	59	216 CDI	04.2000 → 05.2006	OM 612.981	D	71
2.0 D	04.1988 → 08.1993	OM 615.970	D	59	<b>SPRINTER 3,5-t Bus (B906)</b>				
2.0 D	09.1993 → 04.1996	OM 615.970	D	59	310 CDI (906.731, 906.733, 906.735)	03.2009 → 12.2013	OM 651.955	D	36
D	12.1990 → 12.1994	OM 616	D	102	310 CDI (906.731, 906.733, 906.735)	03.2009 → 12.2013	OM 651.956	D	36
D (631.333, 631.343, 631.334, 631.344)	02.1988 → 05.1992	OM 616.963	D	102	311 CDI (906.731, 906.733, 906.735)	06.2006 → 12.2009	OM 646.985	D	72
D (631.333, 631.343, 631.334, 631.344)	12.1990 → 02.1996	OM 616	D	102	311 CDI (906.731, 906.733, 906.735)	05.2016 →	OM 651.955	D	36
D (631.333, 631.343, 631.334, 631.344)	12.1990 → 02.1996	OM 616.963	D	102	311 CDI 4x4 (906.731, 906.733, 906.735)	02.2008 → 12.2009	OM 646.985	D	72
<b>MB Platform/Chassis (631)</b>					313 CDI (906.731, 906.733, 906.735)	08.2011 → 05.2016	OM 651.955	D	36
D (631.340)	02.1988 → 05.1992	OM 616.963	D	102	313 CDI 4x4 (906.731, 906.733, 906.735)	08.2011 → 05.2016	OM 651.955	D	36
D (631.340)	12.1990 → 02.1996	OM 616.963	D	102	314 CDI (906.731, 906.733, 906.735)	05.2016 →	OM 651.955	D	36
<b>MB Van (W631)</b>					314 CDI 4x4 (906.731, 906.733, 906.735)	05.2016 →	OM 651.955	D	36
2.0 D	04.1988 → 08.1993	OM 615.970	D	59	315 CDI (906.731, 906.733, 906.735)	06.2006 → 12.2009	OM 646.986	D	72
2.0 D	09.1993 → 04.1996	OM 615.970	D	59	315 CDI (906.731, 906.733, 906.735)	06.2006 → 12.2009	OM 646.989	D	72
2.4 D	01.1993 → 01.1996	OM 616.963	D	102	315 CDI (906.731, 906.733, 906.735)	06.2006 → 12.2009	OM 646.990	D	72
2.4 D	04.1994 → 09.1996	OM 616.963	D	102	315 CDI (906.733, 906.735)	06.2013 →	OM 651.957	D	36
D (631.332, 631.342)	02.1988 → 05.1992	OM 616.963	D	102	315 CDI 4x4 (906.731, 906.733, 906.735)	02.2008 → 12.2009	OM 646.986	D	72
D (631.332, 631.342)	12.1990 → 02.1996	OM 616.963	D	102	315 CDI (906.733, 906.735)	06.2013 →	OM 651.957	D	36
<b>MB Van (W661)</b>					315 CDI 4x4 (906.731, 906.733, 906.735)	08.2011 →	OM 651.955	D	36
100 2.3 D	11.1999 → 01.2003	OM 661.911	D	87	315 CDI 4x4 (906.731, 906.733, 906.735)	06.2006 → 12.2009	OM 646.989	D	72
100 2.9 D	10.2001 → 05.2005	OM 662.911	D	88	315 CDI (906.731, 906.733, 906.735)	06.2006 → 12.2009	OM 646.990	D	72
140 2.9 D	11.1999 → 05.2005	OM 662.911	D	88	315 CDI (906.731, 906.733, 906.735)	06.2006 → 12.2009	OM 646.990	D	72
<b>SPRINTER (901/902/903/904/905)</b>					315 CDI (906.733, 906.735)	06.2013 →	OM 651.957	D	36
314 CDI	04.2000 → 05.2006	OM 647.981	D	72	315 CDI 4x4 (906.731, 906.733, 906.735)	02.2008 → 12.2009	OM 646.986	D	72
414 CDI	04.2000 → 05.2006	OM 647.981	D	72	315 CDI 4x4 (906.731, 906.733, 906.735)	02.2008 → 12.2009	OM 646.989	D	72
<b>SPRINTER (906)</b>					315 CDI 4x4 (906.731, 906.733, 906.735)	02.2008 → 12.2009	OM 646.989	D	72
322	06.2006 →	M 272.979	B	112	315 CDI 4x4 (906.731, 906.733, 906.735)	02.2008 → 12.2009	OM 646.990	D	72
<b>SPRINTER 2-t Bus (B901, B902)</b>					316 CDI (906.731, 906.733, 906.735)	02.2008 → 12.2009	OM 642.896	D	34
208 CDI	04.2000 → 05.2006	OM 611.987	D	69	316 CDI 4x4 (906.731, 906.733, 906.735)	06.2013 →	OM 651.957	D	36
208 D	02.1995 → 04.2000	OM 601.943	D	83	316 CDI (906.731, 906.733, 906.735)	09.2008 →	M 271.951	BG	17
210 D	03.1997 → 04.2000	OM 602.980	D	85	316 CDI (906.731, 906.733, 906.735)	08.2011 →	OM 651.955	D	36
211 CDI	04.2000 → 05.2006	OM 611.981	D	69	316 CDI (906.731, 906.733, 906.735)	08.2011 →	OM 651.957	D	36
212 D	02.1995 → 04.2000	OM 602.980	D	85	316 CDI 4x4 (906.731, 906.733, 906.735)	08.2011 →	OM 651.955	D	36
213 CDI	04.2000 → 05.2006	OM 611.981	D	69	316 CDI 4x4 (906.731, 906.733, 906.735)	08.2011 →	OM 651.957	D	36
214 (902.071, 902.072, 902.671, 902.672)	02.1995 → 05.2006	M 111.979	BG	98	316 LGT	09.2008 →	M 271.951	BG	17
214 (902.071, 902.072, 902.671, 902.672)	02.1995 → 05.2006	M 111.984	BG	98	316 NGT (906.733)	03.2009 →	M 271.951	BG	17
214 NGT	02.1995 → 05.2006	M 111.979	BG	98	318 CDI (906.731, 906.733, 906.735)	02.2008 → 12.2009	OM 642.896	D	34
214 NGT	02.1995 → 05.2006	M 111.984	BG	98	318 CDI (906.731, 906.733, 906.735)	02.2008 → 12.2009	OM 642.986	D	35
216 CDI	04.2000 → 05.2006	OM 612.981	D	71	318 CDI (906.731, 906.733, 906.735)	02.2008 → 12.2009	OM 642.992	D	34
<b>SPRINTER 2-t Platform/Chassis (B901, B902)</b>					318 CDI (906.731, 906.733, 906.735)	02.2008 → 12.2009	OM 642.993	D	34
208 CDI	04.2000 → 05.2006	OM 611.987	D	69	318 CDI (906.731, 906.733, 906.735)	02.2008 → 12.2009	OM 642.896	D	34
208 D	01.1995 → 04.2000	OM 601.943	D	83	318 CDI 4x4 (906.731, 906.733, 906.735)	02.2008 → 12.2009	OM 642.896	D	34
208 D	09.1996 → 04.2000	OM 601.943	D	83	318 CDI (906.731, 906.733, 906.735)	02.2008 → 12.2009	OM 642.896	D	34
210 D	01.1997 → 04.2000	OM 602.980	D	85	318 CDI (906.731, 906.733, 906.735)	02.2008 → 12.2009	OM 642.896	D	34
211 CDI	04.2000 → 05.2006	OM 611.981	D	69	318 CDI (906.731, 906.733, 906.735)	02.2008 → 12.2009	OM 642.896	D	34
212 D	02.1995 → 04.2000	OM 602.980	D	85	318 CDI (906.731, 906.733, 906.735)	02.2008 → 12.2009	OM 642.896	D	34
213 CDI	04.2000 → 05.2006	OM 611.981	D	69	318 CDI 4x4 (906.731, 906.733, 906.735)	02.2008 → 12.2009	OM 642.896	D	34
214 (902.011, 902.012, 902.611, 902.612)	02.1995 → 05.2006	M 111.979	BG	98					
214 (902.011, 902.012, 902.611, 902.612)	02.1995 → 05.2006	M 111.984	BG	98					

M

		Pos			Pos				
318 CDI 4x4 (906.731, 906.733, 906.735)	02.2008 → 12.2009	OM 642.986	D	<b>35</b>	315 CDI (906.131, 906.133, 906.135, 906.231, 906.233,...)	06.2006 → 12.2009	OM 646.989	D	<b>72</b>
318 CDI 4x4 (906.731, 906.733, 906.735)	02.2008 → 12.2009	OM 642.992	D	<b>34</b>	315 CDI (906.131, 906.133, 906.135, 906.231, 906.233,...)	06.2006 → 12.2009	OM 646.990	D	<b>72</b>
318 CDI 4x4 (906.731, 906.733, 906.735)	02.2008 → 12.2009	OM 642.993	D	<b>34</b>	315 CDI 4x4 (906.131, 906.133, 906.135, 906.231, 906.233,...)	02.2008 → 12.2009	OM 646.986	D	<b>72</b>
319 CDI / BlueTEC (906.731, 906.733, 906.735)	03.2009 →	OM 642.896	D	<b>34</b>	315 CDI 4x4 (906.131, 906.133, 906.135, 906.231, 906.233,...)	02.2008 → 12.2009	OM 646.989	D	<b>72</b>
319 CDI / BlueTEC (906.731, 906.733, 906.735)	03.2009 →	OM 642.898	D	<b>34</b>	315 CDI 4x4 (906.131, 906.133, 906.135, 906.231, 906.233,...)	02.2008 → 12.2009	OM 646.990	D	<b>72</b>
319 CDI / BlueTEC (906.731, 906.733, 906.735)	03.2009 →	OM 642.986	D	<b>35</b>	316 (906.133, 906.135, 906.233, 906.235)	09.2008 →	M 271.951	BG	<b>17</b>
319 CDI / BlueTEC (906.731, 906.733, 906.735)	03.2009 →	OM 642.992	D	<b>34</b>	316 CDI (906.131, 906.133, 906.135, 906.231, 906.233,...)	03.2009 →	OM 651.955	D	<b>36</b>
319 CDI / BlueTEC 4x4 (906.731, 906.733, 906.735)	03.2009 →	OM 642.896	D	<b>34</b>	316 CDI (906.131, 906.133, 906.135, 906.231, 906.233,...)	03.2009 →	OM 651.957	D	<b>36</b>
319 CDI / BlueTEC 4x4 (906.731, 906.733, 906.735)	03.2009 →	OM 642.898	D	<b>34</b>	316 CDI 4x4 (906.131, 906.133, 906.135, 906.231, 906.233,...)	03.2009 →	OM 651.955	D	<b>36</b>
319 CDI / BlueTEC 4x4 (906.731, 906.733, 906.735)	03.2009 →	OM 642.986	D	<b>35</b>	316 CDI 4x4 (906.131, 906.133, 906.135, 906.231, 906.233,...)	03.2009 →	OM 651.957	D	<b>36</b>
319 CDI / BlueTEC 4x4 (906.731, 906.733, 906.735)	03.2009 →	OM 642.992	D	<b>34</b>	316 LGT (906.133, 906.135, 906.233, 906.235)	09.2008 →	M 271.951	BG	<b>17</b>
324 (906.733, 906.735)	06.2006 → 12.2013	M 272.979	B	<b>112</b>	316 NGT (906.133, 906.135, 906.233, 906.235)	09.2008 →	M 271.951	BG	<b>17</b>
<b>SPRINTER 3,5-t Platform/Chassis (B906)</b>									
309 CDI (906.131, 906.133, 906.135, 906.231, 906.233,...)	06.2006 → 12.2009	OM 646.984	D	<b>72</b>	318 CDI (906.131, 906.133, 906.135, 906.231, 906.233,...)	06.2006 → 12.2009	OM 642.896	D	<b>34</b>
310 CDI (906.131, 906.133, 906.135, 906.231, 906.233,...)	03.2009 → 05.2016	OM 651.955	D	<b>36</b>	318 CDI (906.131, 906.133, 906.135, 906.231, 906.233,...)	06.2006 → 12.2009	OM 642.992	D	<b>34</b>
310 CDI (906.131, 906.133, 906.135, 906.231, 906.233,...)	03.2009 → 05.2016	OM 651.956	D	<b>36</b>	318 CDI (906.131, 906.133, 906.135, 906.231, 906.233,...)	06.2006 → 12.2009	OM 642.993	D	<b>34</b>
311 CDI (906.131, 906.133, 906.135, 906.231, 906.233,...)	06.2011 → 12.2016	OM 651.957	D	<b>36</b>	318 CDI 4x4 (906.131, 906.133, 906.135, 906.231, 906.233,...)	02.2008 → 12.2009	OM 642.896	D	<b>34</b>
311 CDI (906.131, 906.133, 906.135, 906.231, 906.233,...)	06.2006 → 12.2009	OM 646.985	D	<b>72</b>	318 CDI 4x4 (906.131, 906.133, 906.135, 906.231, 906.233,...)	02.2008 → 12.2009	OM 642.992	D	<b>34</b>
311 CDI (906.131, 906.133, 906.135, 906.231, 906.233,...)	05.2016 →	OM 651.955	D	<b>36</b>	318 CDI 4x4 (906.131, 906.133, 906.135, 906.231, 906.233,...)	02.2008 → 12.2009	OM 642.993	D	<b>34</b>
311 CDI 4x4 (906.131, 906.133, 906.135, 906.231, 906.233,...)	02.2008 → 12.2009	OM 646.985	D	<b>72</b>	319 CDI / BlueTEC (906.131, 906.133, 906.135, 906.231, 906.233,...)	03.2009 →	OM 642.896	D	<b>34</b>
313 CDI (906.131, 906.133, 906.135, 906.231, 906.233,...)	06.2006 → 05.2016	OM 646.986	D	<b>72</b>	319 CDI / BlueTEC (906.131, 906.133, 906.135, 906.231, 906.233,...)	03.2009 →	OM 642.898	D	<b>34</b>
313 CDI (906.131, 906.133, 906.135, 906.231, 906.233,...)	06.2006 → 05.2016	OM 651.955	D	<b>36</b>	319 CDI / BlueTEC (906.131, 906.133, 906.135, 906.231, 906.233,...)	03.2009 →	OM 642.992	D	<b>34</b>
313 CDI (906.131, 906.133, 906.135, 906.231, 906.233,...)	06.2006 → 05.2016	OM 651.956	D	<b>36</b>	319 CDI / BlueTEC 4x4 (906.131, 906.133, 906.135, 906.231, 906.233,...)	05.2011 →	OM 642.896	D	<b>34</b>
313 CDI 4x4 (906.131, 906.133, 906.135, 906.231, 906.233,...)	06.2006 → 05.2016	OM 651.955	D	<b>36</b>	319 CDI / BlueTEC 4x4 (906.131, 906.133, 906.135, 906.231, 906.233,...)	05.2011 →	OM 642.898	D	<b>34</b>
314 CDI (906.131, 906.133, 906.135, 906.231, 906.233,...)	05.2016 →	OM 651.955	D	<b>36</b>	319 CDI / BlueTEC 4x4 (906.131, 906.133, 906.135, 906.231, 906.233,...)	05.2011 →	OM 642.992	D	<b>34</b>
314 CDI 4x4 (906.131, 906.133, 906.135, 906.231, 906.233,...)	05.2016 →	OM 651.955	D	<b>36</b>					
315 CDI (906.131, 906.133, 906.135, 906.231, 906.233,...)	06.2006 → 12.2009	OM 646.986	D	<b>72</b>					

M



		Pos			Pos			
324 (906.133, 906.135, 906.233, 906.235, 906.132,...)	M 272.979	B	112	311 CDI (906.631, 906.633, 906.635, 906.637)	05.2016 →	OM 651.955	D	36
<b>SPRINTER 3,5-t Platform/Chassis (B907, B910)</b>				311 CDI 4x4 (906.631, 906.633, 906.635, 906.637)	02.2008 → 12.2009	OM 646.985	D	72
311 CDI (910.131, 910.133)	OM 651.950	D	41	313 CDI (906.631, 906.633, 906.635, 906.637)	06.2006 →	OM 646.986	D	72
311 CDI (910.131, 910.133)	OM 651.958	D	45	313 CDI (906.631, 906.633, 906.635, 906.637)	05.2009 →	OM 651.940	D	36
311 CDI RWD (907.131, 907.133, 907.135, 907.231, 907.233...)	OM 651.958	D	45	313 CDI (906.631, 906.633, 906.635, 906.637)	05.2009 →	OM 651.955	D	36
311 CDI RWD (907.131, 907.133, 907.135, 907.231, 907.233...)	OM 654.920	D	27	313 CDI (906.631, 906.633, 906.635, 906.637)	05.2009 →	OM 651.955	D	36
314 CDI (910.131, 910.133)	OM 651.950	D	41	313 CDI 4x4 (906.631, 906.633, 906.635, 906.637)	05.2009 →	OM 651.955	D	36
314 CDI (910.131, 910.133)	OM 651.958	D	45	314 CDI (906.631, 906.633, 906.635, 906.637)	05.2016 →	OM 651.955	D	36
314 CDI All-wheel Drive (907.133, 907.135, 907.233,...)	OM 651.958	D	45	314 CDI 4x4 (906.631, 906.633, 906.635, 906.637)	05.2016 →	OM 651.955	D	36
314 CDI RWD (907.131, 907.133, 907.135, 907.231, 907.233...)	OM 651.958	D	45	315 CDI (906.631, 906.633, 906.635, 906.637)	06.2006 → 12.2009	OM 646.986	D	72
315 CDI RWD (907.131, 907.133, 907.135, 907.231, 907.233...)	OM 654.920	D	27	315 CDI (906.631, 906.633, 906.635, 906.637)	06.2006 → 12.2009	OM 646.989	D	72
316 CDI All-wheel Drive (907.133, 907.135, 907.233,...)	OM 651.958	D	45	315 CDI (906.631, 906.633, 906.635, 906.637)	06.2006 → 12.2009	OM 646.990	D	72
316 CDI RWD (907.131, 907.133, 907.135, 907.231, 907.233...)	OM 651.958	D	45	315 CDI (906.633)	12.2014 →	OM 651.955	D	36
317 CDI RWD (907.131, 907.133, 907.135, 907.231, 907.233...)	OM 654.920	D	27	315 CDI 4x4 (906.631, 906.633, 906.635, 906.637)	02.2008 → 12.2009	OM 646.986	D	72
319 CDI All-wheel Drive (907.133, 907.135, 907.233)	OM 642.899	D	34	315 CDI 4x4 (906.631, 906.633, 906.635, 906.637)	02.2008 → 12.2009	OM 646.989	D	72
319 CDI RWD (907.133, 907.135, 907.233, 907.235)	OM 642.899	D	34	315 CDI 4x4 (906.631, 906.633, 906.635, 906.637)	02.2008 → 12.2009	OM 646.990	D	72
<b>SPRINTER 3,5-t Tourer Bus (B907)</b>				316 (906.635, 906.633)	09.2008 →	M 271.951	BG	17
311 CDI (907.731, 907.733, 907.735)	OM 651.958	D	45	316 CDI (906.631, 906.633, 906.635, 906.637)	03.2009 →	OM 651.955	D	36
314 CDI (907.731, 907.733, 907.735)	OM 651.958	D	45	316 CDI (906.631, 906.633, 906.635, 906.637)	03.2009 →	OM 651.957	D	36
314 CDI All-wheel Drive (907.733)	OM 651.958	D	45	316 CDI 4x4 (906.631, 906.633, 906.635, 906.637)	03.2009 →	OM 651.955	D	36
316 CDI (907.731, 907.733, 907.735)	OM 651.958	D	45	316 CDI 4x4 (906.631, 906.633, 906.635, 906.637)	03.2009 →	OM 651.957	D	36
316 CDI All-wheel Drive (907.733)	OM 651.958	D	45	316 LGT (906.633, 906.635)	09.2008 →	M 271.951	BG	17
319 CDI (907.733, 907.735)	OM 642.899	D	34	316 NGT (906.633, 906.635)	09.2008 →	M 271.951	BG	17
319 CDI All-wheel Drive (907.733)	OM 642.899	D	34	318 CDI (906.631, 906.633, 906.635, 906.637)	06.2006 → 12.2009	OM 642.896	D	34
<b>SPRINTER 3,5-t Van (B906)</b>				318 CDI (906.631, 906.633, 906.635, 906.637)	06.2006 → 12.2009	OM 642.986	D	35
309 CDI (906.631, 906.633, 906.635, 906.637)	OM 646.984	D	72	318 CDI (906.631, 906.633, 906.635, 906.637)	06.2006 → 12.2009	OM 642.992	D	34
310 CDI (906.631, 906.633, 906.635, 906.637)	OM 651.955	D	36	318 CDI (906.631, 906.633, 906.635, 906.637)	06.2006 → 12.2009	OM 642.993	D	34
310 CDI (906.631, 906.633, 906.635, 906.637)	OM 651.956	D	36	318 CDI (906.631, 906.633, 906.635, 906.637)	06.2006 → 12.2009	OM 642.993	D	34
311 CDI (906.631, 906.633, 906.635, 906.637)	OM 646.985	D	72					

M





		Pos			Pos		
314 (903.011, 903.012, 903.013, 903.022, 903.611,...	M 111.979	BG	98	211 CDI RWD (907.123, 907.221, 907.223)	OM 651.958	D	45
314 (903.011, 903.012, 903.013, 903.022, 903.611,...	M 111.984	BG	98	211 CDI RWD (907.221, 907.223)	OM 654.920	D	27
314 4x4	M 111.984	BG	98	214 CDI (910.121, 910.123)	OM 651.950	D	41
314 NGT (903.611, 903.612)	M 111.979	BG	98	214 CDI (910.121, 910.123)	OM 651.958	D	45
314 NGT (903.611, 903.612)	M 111.984	BG	98	214 CDI RWD (907.221, 907.223)	OM 651.958	D	45
316 CDI	OM 612.981	D	71	215 CDI RWD (907.221, 907.223)	OM 654.920	D	27
316 CDI	OM 647.981	D	72	216 CDI RWD (907.221, 907.223)	OM 651.958	D	45
316 CDI 4x4	OM 612.981	D	71	217 CDI RWD (907.221, 907.223)	OM 654.920	D	27
316 CDI 4x4	OM 647.981	D	72				
<b>SPRINTER 3-t Platform/Chassis (B906)</b>				<b>SPRINTER 3-t Tourer Bus (B907)</b>			
209 CDI (906.111, 906.113, 906.211, 906.213)	OM 646.984	D	72	211 CDI (907.721, 907.723)	OM 651.958	D	45
210 CDI (906.111, 906.113, 906.211, 906.213)	OM 651.955	D	36	214 CDi (907.721, 907.723)	OM 651.958	D	45
211 CDI (906.111, 906.113, 906.211, 906.213)	OM 646.985	D	72	<b>SPRINTER 3-t Van (B903)</b>			
211 CDI (906.111, 906.113, 906.211, 906.213)	OM 651.955	D	36	308 CDI	OM 611.987	D	69
213 CDI (906.111, 906.113, 906.211, 906.213)	OM 646.986	D	72	308 D 2.3	OM 601.943	D	83
213 CDI (906.111, 906.113, 906.211, 906.213)	OM 651.955	D	36	308 D 2.3	OM 601.943	D	83
214 CDI (906.111, 906.113, 906.211, 906.213)	OM 651.955	D	36	310 D 2.9	OM 602.980	D	85
215 CDI (906.111, 906.113, 906.211, 906.213)	OM 646.986	D	72	310 D 2.9 4x4	OM 602.980	D	85
215 CDI (906.111, 906.113, 906.211, 906.213)	OM 651.955	D	36	311 CDI	OM 611.981	D	69
216 (906.113, 906.213)	OM 642.896	D	34	311 CDI 4x4	OM 611.981	D	69
216 CDI (906.111, 906.113, 906.211, 906.213)	OM 642.992	D	34	312 D 2.9	OM 602.980	D	85
218 CDI (906.111, 906.113, 906.211, 906.213)	OM 642.993	D	34	312 D 2.9 4x4	OM 602.980	D	85
219 CDI / BlueTEC (906.111, 906.113, 906.211, 906.213)	OM 642.896	D	34	313 CDI (903.663, 903.662, 903.661)	OM 611.981	D	69
219 CDI / BlueTEC (906.111, 906.113, 906.211, 906.213)	OM 642.992	D	34	313 CDI 4x4	OM 611.981	D	69
224 (906.113, 906.213)	M 272.979	B	112	314	M 111.979	BG	98
<b>SPRINTER 3-t Platform/Chassis (B910, B907)</b>				314	M 111.984	BG	98
211 CDI (910.121, 910.123)	OM 651.950	D	41	314 4x4	M 111.984	BG	98
				314 NGT (903.661)	M 111.979	BG	98
				314 NGT (903.661)	M 111.984	BG	98
				316 CDI	OM 612.981	D	71
				316 CDI	OM 647.981	D	72
				316 CDI 4x4	OM 612.981	D	71
				316 CDI 4x4	OM 647.981	D	72
				<b>SPRINTER 3-t Van (B906)</b>			
				209 CDI (906.611, 906.613)	OM 646.984	D	72
				210 CDI (906.611, 906.613)	OM 651.955	D	36
				211 CDI (906.611, 906.613)	OM 646.985	D	72
				211 CDI (906.611, 906.613)	OM 651.955	D	36
				213 CDI (906.611, 906.613)	OM 646.986	D	72
				213 CDI (906.611, 906.613)	OM 651.955	D	36
				213 CDI (906.611, 906.613)	OM 651.957	D	36
				214 CDI (906.611, 906.613)	OM 651.955	D	36
				215 CDI (906.611, 906.613)	OM 646.986	D	72
				215 CDI (906.611, 906.613)	OM 646.989	D	72
				215 CDI (906.611, 906.613)	OM 646.990	D	72
				216 (906.613)	M 271.951	BG	17
				216 CDI (906.611, 906.613)	OM 651.955	D	36
				216 CDI (906.611, 906.613)	OM 651.957	D	36

M

		Pos			Pos
218 CDI (906.611, 906.613) 06.2006 → 12.2009	OM 642.896 D	34	411 CDI (906.653, 906.655, 906.657) 06.2009 → 12.2018	OM 646.985 D	72
218 CDI (906.611, 906.613) 06.2006 → 12.2009	OM 642.992 D	34	413 CDI (906.653, 906.655, 906.657) 06.2006 → 05.2016	OM 651.955 D	36
219 CDI / BlueTEC (906.611, 906.613) 03.2009 →	OM 642.896 D	34	413 CDI (906.653, 906.655, 906.657) 06.2006 → 05.2016	OM 651.956 D	36
219 CDI / BlueTEC (906.611, 906.613) 03.2009 →	OM 642.992 D	34	414 CDI 05.2016 →	OM 651.955 D	36
224 (906.613) 06.2006 →	M 272.979 B	112	414 CDI 4x4 05.2016 →	OM 651.955 D	36
<b>SPRINTER 3-t Van (B910)</b>			415 CDI 03.2012 →	OM 651.955 D	36
211 CDI (910.621, 910.623) 02.2018 →	OM 651.950 D	41	415 CDI 03.2012 →	OM 651.957 D	36
211 CDI (910.621, 910.623) 02.2018 →	OM 651.958 D	45	415 CDI (906.653, 906.655, 906.657) 06.2009 → 12.2009	OM 646.986 D	72
214 CDI (910.621, 910.623) 02.2018 →	OM 651.950 D	41	415 CDI (906.653, 906.655, 906.657) 06.2009 → 12.2009	OM 646.989 D	72
214 CDI (910.621, 910.623) 02.2018 →	OM 651.958 D	45	415 CDI (906.653, 906.655, 906.657) 06.2009 → 12.2009	OM 646.990 D	72
<b>SPRINTER 4,6-t Bus (B906)</b>			416 CDI (906.653, 906.655, 906.657) 03.2009 →	OM 651.955 D	36
415 CDI 06.2006 →	OM 651.957 D	36	416 CDI 4x4 11.2013 →	OM 651.955 D	36
<b>SPRINTER 4,6-t Platform/Chassis (B906)</b>			416 CDI 4x4 11.2013 →	OM 651.957 D	36
411 CDI (906.153, 906.155, 906.253, 906.255) 06.2009 → 12.2018	OM 646.985 D	72	418 CDI (906.653, 906.655, 906.657) 06.2009 → 05.2016	OM 642.896 D	34
411 CDI (906.153, 906.155, 906.253, 906.255) 04.2016 →	OM 651.955 D	36	418 CDI (906.653, 906.655, 906.657) 06.2009 → 05.2016	OM 642.986 D	35
413 CDI 03.2009 →	OM 651.955 D	36	418 CDI (906.653, 906.655, 906.657) 06.2009 → 05.2016	OM 642.992 D	34
414 CDI 05.2016 →	OM 651.955 D	36	419 CDI (906.653, 906.655, 906.657) 03.2009 →	OM 642.896 D	34
415 CDI 01.2012 →	OM 651.957 D	36	419 CDI (906.653, 906.655, 906.657) 03.2009 →	OM 642.992 D	34
415 CDI (906.153, 906.155, 906.253, 906.255) 06.2006 → 12.2009	OM 646.986 D	72	424 (906.655, 906.657, 906.653) 06.2006 → 12.2013	M 272.979 B	112
415 CDI (906.153, 906.155, 906.253, 906.255) 06.2006 → 12.2009	OM 646.989 D	72	<b>SPRINTER 4-t Bus (B904)</b>		
415 CDI (906.153, 906.155, 906.253, 906.255) 06.2006 → 12.2009	OM 646.990 D	72	408 CDI 04.2000 → 05.2006	OM 611.987 D	69
416 CDI (906.153, 906.155, 906.253, 906.255) 03.2009 →	OM 651.955 D	36	411 CDI 04.2000 → 05.2006	OM 611.981 D	69
416 CDI (906.153, 906.155, 906.253, 906.255) 03.2009 →	OM 651.957 D	36	413 CDI 04.2000 → 05.2006	OM 611.981 D	69
418 CDI (906.153, 906.155, 906.253, 906.255) 06.2006 → 12.2009	OM 642.896 D	34	414 02.1996 → 05.2006	M 111.979 BG	98
418 CDI (906.153, 906.155, 906.253, 906.255) 06.2006 → 12.2009	OM 642.986 D	35	414 02.1996 → 05.2006	M 111.984 BG	98
418 CDI (906.153, 906.155, 906.253, 906.255) 06.2006 → 12.2009	OM 642.992 D	34	416 CDI 04.2000 → 05.2006	OM 612.981 D	71
418 CDI (906.153, 906.155, 906.253, 906.255) 06.2006 → 12.2009	OM 642.993 D	34	<b>SPRINTER 4-t Platform/Chassis (B904)</b>		
419 CDI (906.153, 906.155, 906.253, 906.255) 03.2009 →	OM 642.896 D	34	408 CDI 04.2000 → 05.2006	OM 611.987 D	69
419 CDI (906.153, 906.155, 906.253, 906.255) 03.2009 →	OM 642.898 D	34	408 D 02.1996 → 05.2006	OM 601.943 D	83
419 CDI (906.153, 906.155, 906.253, 906.255) 03.2009 →	OM 642.986 D	35	410 D 02.1996 → 05.2006	OM 602.980 D	85
419 CDI (906.153, 906.155, 906.253, 906.255) 03.2009 →	OM 642.986 D	35	410 D 4x4 05.1997 → 05.2006	OM 602.980 D	85
419 CDI (906.153, 906.155, 906.253, 906.255) 03.2009 →	OM 642.992 D	34	411 CDI 04.2000 → 05.2006	OM 611.981 D	69
424 (906.153, 906.155, 906.253, 906.255) 06.2006 → 12.2013	M 272.979 B	112	411 CDI 4x4 04.2000 → 05.2006	OM 611.981 D	69
<b>SPRINTER 4,6-t Van (B906)</b>			412 D 02.1996 → 05.2006	OM 602.980 D	85
			412 D 02.1996 → 05.2006	OM 602.980 D	85
			412 D 4x4 05.1997 → 05.2006	OM 602.980 D	85
			412 D 4x4 05.1997 → 05.2006	OM 602.980 D	85
			413 CDI 04.2000 → 05.2006	OM 611.981 D	69
			413 CDI 4x4 04.2000 → 05.2006	OM 611.981 D	69
			414 (904.012, 904.013, 904.612, 904.613) 02.1995 → 05.2006	M 111.979 BG	98
			414 (904.012, 904.013, 904.612, 904.613) 02.1995 → 05.2006	M 111.984 BG	98
			414 4x4 (904.012, 904.013, 904.612, 904.613) 05.1997 → 05.2006	M 111.979 BG	98
			414 4x4 (904.012, 904.013, 904.612, 904.613) 05.1997 → 05.2006	M 111.984 BG	98
			414 NGT 02.1995 → 05.2006	M 111.979 BG	98
			414 NGT 02.1995 → 05.2006	M 111.984 BG	98
			416 CDI 04.2000 → 05.2006	OM 612.981 D	71
			416 CDI 04.2000 → 05.2006	OM 647.981 D	72
			416 CDI 4x4 04.2000 → 05.2006	OM 612.981 D	71
			416 CDI 4x4 04.2000 → 05.2006	OM 647.981 D	72
<b>SPRINTER 4,6-t Van (B906)</b>			<b>SPRINTER 4-t Platform/Chassis (B907, B910)</b>		

			Pos				Pos		
411 CDI (910.143)	02.2018 →	OM 651.950	D	41	414 CDI All-wheel Drive 01.2019 →	OM 651.958	D	45	
411 CDI (910.143)	02.2018 →	OM 651.958	D	45	(907.643, 907.645, 907.647)				
411 CDI RWD (907.141, 907.143, 907.145, 907.241, 907.243...)	02.2018 →	OM 651.958	D	45	414 CDI RWD (907.643, 907.645, 907.647)	OM 651.958	D	45	
414 CDI (910.141, 910.143)	02.2018 →	OM 651.950	D	41	416 CDI All-wheel Drive 01.2019 →	OM 651.958	D	45	
414 CDI (910.141, 910.143)	02.2018 →	OM 651.958	D	45	(907.643, 907.645, 907.647)				
414 CDI All-wheel Drive (907.143, 907.145, 907.243,...)	01.2019 →	OM 651.958	D	45	416 CDI RWD (907.643, 907.645, 907.647)	OM 651.958	D	45	
414 CDI RWD (907.143, 907.145, 907.243, 907.245, 907.141...)	02.2018 →	OM 651.958	D	45	417 CDI RWD (907.641, 907.643, 907.645, 907.647)	OM 654.920	D	27	
416 CDI All-wheel Drive (907.143, 907.145, 907.243,...)	01.2019 →	OM 651.958	D	45	419 CDI All-wheel Drive 01.2019 →	OM 642.899	D	34	
416 CDI RWD (907.143, 907.145, 907.243, 907.141, 907.241...)	02.2018 →	OM 651.958	D	45	(907.643, 907.645, 907.647)				
419 CDI All-wheel Drive (907.143, 907.145, 907.243,...)	01.2019 →	OM 642.899	D	34	419 CDI RWD (907.643, 907.645, 907.647)	OM 642.899	D	34	
419 CDI RWD (907.143, 907.145, 907.243, 907.245)	02.2018 →	OM 642.899	D	34	<b>SPRINTER 5-t Bus (B906)</b>				
<b>SPRINTER 4-t Tourer Bus (B907)</b>				<b>SPRINTER 5-t Platform/Chassis (B905)</b>					
414 CDI (907.643)	09.2019 →	OM 651.958	D	45	513 CDI (906.655, 906.657)	OM 651.955	D	36	
416 CDI (907.843)	09.2019 →	OM 651.958	D	45	515 CDI (906.755, 906.757)	OM 651.957	D	36	
<b>SPRINTER 4-t Van (B904)</b>				<b>SPRINTER 5-t Platform/Chassis (B906)</b>					
408 CDI	04.2000 → 05.2006	OM 611.987	D	69	516 CDI (906.655, 906.657)	OM 651.955	D	36	
408 D	02.1996 → 05.2006	OM 601.943	D	83	519 CDI (906.655, 906.657)	OM 642.896	D	34	
410 D	02.1996 → 05.2006	OM 602.980	D	85	616 CDI (905.612, 905.613, 905.622, 905.623)	OM 612.981	D	71	
410 D 4x4	05.1997 → 05.2006	OM 602.980	D	85	<b>SPRINTER 5-t Platform/Chassis (B906)</b>				
411 CDI	04.2000 → 05.2006	OM 611.981	D	69	509 CDI (906.153, 906.155, 906.253, 906.255)	OM 646.984	D	72	
411 CDI 4x4	04.2000 → 05.2006	OM 611.981	D	69	510 CDI (906.153, 906.155, 906.253, 906.255)	OM 651.955	D	36	
412 D	02.1996 → 05.2006	OM 602.980	D	85	511 CDI (906.153, 906.155, 906.253, 906.255)	OM 646.985	D	72	
412 D	02.1996 → 05.2006	OM 602.980	D	85	511 CDI (906.153, 906.155, 906.253, 906.255)	OM 646.986	D	72	
412 D 4x4	05.1997 → 05.2006	OM 602.980	D	85	511 CDI (906.153, 906.155, 906.253, 906.255)	OM 651.955	D	36	
412 D 4x4	05.1997 → 05.2006	OM 602.980	D	85	511 CDI (906.153, 906.155, 906.253, 906.255)	OM 651.957	D	36	
413 CDI	04.2000 → 05.2006	OM 611.981	D	69	513 CDI (906.155, 906.155, 906.253, 906.255)	OM 651.955	D	36	
413 CDI 4x4	04.2000 → 05.2006	OM 611.981	D	69	513 CDI 4x4 (906.155, 906.155, 906.253, 906.255)	OM 651.955	D	36	
414 (904.062, 904.063, 904.662, 904.663)	02.1996 → 05.2006	M 111.979	BG	98	513 CDI 4x4 (906.155, 906.155, 906.253, 906.255)	OM 651.957	D	36	
414 (904.062, 904.063, 904.662, 904.663)	02.1996 → 05.2006	M 111.984	BG	98	514 CDI (906.153, 906.155, 906.253, 906.255)	OM 651.955	D	36	
414 4x4 (904.062, 904.063, 904.662, 904.663)	05.1997 → 05.2006	M 111.979	BG	98	514 CDI 4x4 (906.153, 906.155, 906.253, 906.255)	OM 651.955	D	36	
414 4x4 (904.062, 904.063, 904.662, 904.663)	05.1997 → 05.2006	M 111.984	BG	98	514 CDI 4x4 (906.153, 906.155, 906.253, 906.255)	OM 651.955	D	36	
414 D 4x4	05.1997 → 05.2006	OM 602.980	D	85	514 CDI 4x4 (906.153, 906.155, 906.253, 906.255)	OM 651.955	D	36	
414 NGT	02.1995 → 05.2006	M 111.979	BG	98	514 CDI 4x4 (906.153, 906.155, 906.253, 906.255)	OM 651.955	D	36	
414 NGT	02.1995 → 05.2006	M 111.984	BG	98	514 CDI 4x4 (906.153, 906.155, 906.253, 906.255)	OM 651.955	D	36	
416 CDI	04.2000 → 05.2006	OM 612.981	D	71	514 CDI 4x4 (906.153, 906.155, 906.253, 906.255)	OM 651.955	D	36	
416 CDI	04.2000 → 05.2006	OM 647.981	D	72	514 CDI 4x4 (906.153, 906.155, 906.253, 906.255)	OM 651.955	D	36	
416 CDI 4x4	04.2000 → 05.2006	OM 612.981	D	71	514 CDI 4x4 (906.153, 906.155, 906.253, 906.255)	OM 651.955	D	36	
416 CDI 4x4	04.2000 → 05.2006	OM 647.981	D	72	514 CDI 4x4 (906.153, 906.155, 906.253, 906.255)	OM 651.955	D	36	
<b>SPRINTER 4-t Van (B907, B910)</b>				<b>SPRINTER 5-t Platform/Chassis (B906)</b>					
411 CDI (910.641, 910.643)	02.2018 →	OM 651.950	D	41	515 CDI (906.153, 906.155, 906.253, 906.255)	OM 651.957	D	36	
411 CDI (910.641, 910.643)	02.2018 →	OM 651.958	D	45	515 CDI (906.153, 906.155, 906.253, 906.255)	OM 646.986	D	72	
411 CDI RWD (907.643, 907.645)	02.2018 →	OM 651.958	D	45	515 CDI (906.153, 906.155, 906.253, 906.255)	OM 646.989	D	72	
414 CDI (910.643, 910.641)	02.2018 →	OM 651.958	D	45	515 CDI (906.153, 906.155, 906.253, 906.255)	OM 646.990	D	72	

M



		Pos			Pos
515 CDI 4x4 (906.153, 906.155, 906.253, 906.255) 06.2006 → 12.2009	OM 646.986 D	72	524 (906.153, 906.155, 906.253, 906.255) 06.2006 → 12.2013	M 272.979 B	112
515 CDI 4x4 (906.153, 906.155, 906.253, 906.255) 06.2006 → 12.2009	OM 646.989 D	72	<b>SPRINTER 5-t Platform/Chassis (B907)</b>		
515 CDI 4x4 (906.153, 906.155, 906.253, 906.255) 06.2006 → 12.2009	OM 646.990 D	72	511 CDI (907.153, 907.155, 907.253, 907.255) 02.2018 →	OM 651.958 D	45
516 (906.153, 906.155, 906.253, 906.255) 09.2008 →	M 271.951 BG	17	514 CDI (907.153, 907.155, 907.253, 907.255) 02.2018 →	OM 651.958 D	45
516 CDI (906.153, 906.155, 906.253, 906.255) 03.2009 →	OM 651.955 D	36	516 CDI (907.153, 907.155, 907.253, 907.255) 02.2018 →	OM 651.958 D	45
516 CDI (906.153, 906.155, 906.253, 906.255) 03.2009 →	OM 651.957 D	36	516 CDI All-wheel Drive (907.153, 907.155, 907.253,...) 01.2019 →	OM 651.958 D	45
516 CDI 4x4 (906.153, 906.155, 906.255) 05.2011 →	OM 651.955 D	36	519 CDI (907.153, 907.155, 907.253, 907.255) 02.2018 →	OM 642.899 D	34
516 CDI 4x4 (906.153, 906.155, 906.255) 05.2011 →	OM 651.957 D	36	519 CDI All-wheel Drive (907.153, 907.155, 907.253,...) 01.2019 →	OM 642.899 D	34
516 NGT (906.153, 906.155, 906.253, 906.255) 09.2008 →	M 271.951 BG	17	<b>SPRINTER 5-t Tourer Bus (B907)</b>		
518 CDI (906.153, 906.155, 906.253, 906.255) 06.2006 → 12.2009	OM 642.896 D	34	516 CDI (907.855, 907.857) 09.2019 →	OM 651.958 D	45
518 CDI (906.153, 906.155, 906.253, 906.255) 06.2006 → 12.2009	OM 642.986 D	35	<b>SPRINTER 5-t Van (B906)</b>		
518 CDI (906.153, 906.155, 906.253, 906.255) 06.2006 → 12.2009	OM 642.992 D	34	509 CDI (906.653, 906.655, 906.657) 06.2006 → 12.2009	OM 646.984 D	72
518 CDI (906.153, 906.155, 906.253, 906.255) 06.2006 → 12.2009	OM 642.993 D	34	510 CDI (906.653, 906.655, 906.657) 03.2009 → 05.2016	OM 651.955 D	36
518 CDI 4x4 (906.153, 906.155, 906.253, 906.255) 06.2006 → 12.2009	OM 642.896 D	34	511 CDI (906.653, 906.655, 906.657) 06.2006 → 12.2009	OM 646.985 D	72
518 CDI 4x4 (906.153, 906.155, 906.253, 906.255) 06.2006 → 12.2009	OM 642.992 D	34	511 CDI (906.653, 906.655, 906.657) 05.2016 →	OM 651.955 D	36
518 CDI 4x4 (906.153, 906.155, 906.253, 906.255) 06.2006 → 12.2009	OM 642.993 D	34	511 CDI 4x4 (906.653, 906.655, 906.657) 06.2006 → 12.2009	OM 646.985 D	72
519 CDI / BlueTEC (906.153, 906.155, 906.253, 906.255) 03.2009 →	OM 642.896 D	34	513 CDI (906.653, 906.655, 906.657) 06.2006 →	OM 646.986 D	72
519 CDI / BlueTEC (906.153, 906.155, 906.253, 906.255) 03.2009 →	OM 642.898 D	34	513 CDI (906.653, 906.655, 906.657) 06.2006 →	OM 651.955 D	36
519 CDI / BlueTEC (906.153, 906.155, 906.253, 906.255) 03.2009 →	OM 642.986 D	35	513 CDI (906.653, 906.655, 906.657) 06.2006 →	OM 651.957 D	36
519 CDI / BlueTEC (906.153, 906.155, 906.253, 906.255) 03.2009 →	OM 642.992 D	34	513 CDI 4x4 (906.653, 906.655, 906.657) 06.2006 →	OM 651.955 D	36
519 CDI / BlueTEC 4x4 (906.153, 906.155, 906.253,...) 03.2009 →	OM 642.896 D	34	513 CDI 4x4 (906.653, 906.655, 906.657) 06.2006 →	OM 651.957 D	36
519 CDI / BlueTEC 4x4 (906.153, 906.155, 906.253,...) 03.2009 →	OM 642.898 D	34	514 CDI (906.653, 906.655, 906.657) 05.2016 →	OM 651.955 D	36
519 CDI / BlueTEC 4x4 (906.153, 906.155, 906.253,...) 03.2009 →	OM 642.986 D	35	514 CDI 4x4 (906.653, 906.655, 906.657) 05.2016 →	OM 651.955 D	36
519 CDI / BlueTEC 4x4 (906.153, 906.155, 906.253,...) 03.2009 →	OM 642.992 D	34	515 CDI (906.653, 906.655, 906.657) 06.2006 → 12.2009	OM 646.986 D	72
519 CDI / BlueTEC 4x4 (906.153, 906.155, 906.253,...) 03.2009 →	OM 642.896 D	34	515 CDI (906.653, 906.655, 906.657) 06.2006 → 12.2009	OM 646.989 D	72
519 CDI / BlueTEC 4x4 (906.153, 906.155, 906.253,...) 03.2009 →	OM 642.986 D	35	515 CDI (906.653, 906.655, 906.657) 06.2006 → 12.2009	OM 646.990 D	72
519 CDI / BlueTEC 4x4 (906.153, 906.155, 906.253,...) 03.2009 →	OM 642.992 D	34	515 CDI (906.655, 906.957, 906.657) 06.2011 →	OM 651.955 D	36
519 CDI / BlueTEC 4x4 (906.153, 906.155, 906.253,...) 03.2009 →	OM 642.896 D	34	515 CDI 4x4 (906.653, 906.655, 906.657) 06.2006 → 12.2009	OM 646.986 D	72
519 CDI / BlueTEC 4x4 (906.153, 906.155, 906.253,...) 03.2009 →	OM 642.898 D	34	515 CDI 4x4 (906.653, 906.655, 906.657) 06.2006 → 12.2009	OM 646.989 D	72
519 CDI / BlueTEC 4x4 (906.153, 906.155, 906.253,...) 03.2009 →	OM 642.986 D	35	515 CDI 4x4 (906.653, 906.655, 906.657) 06.2006 → 12.2009	OM 646.990 D	72
519 CDI / BlueTEC 4x4 (906.153, 906.155, 906.253,...) 03.2009 →	OM 642.992 D	34	516 (906.653, 906.655, 906.657) 03.2009 →	M 271.951 BG	17
519 CDI / BlueTEC 4x4 (906.153, 906.155, 906.253,...) 03.2009 →	OM 642.896 D	34	516 CDI (906.653, 906.655, 906.657) 03.2009 →	OM 651.955 D	36
519 CDI / BlueTEC 4x4 (906.153, 906.155, 906.253,...) 03.2009 →	OM 642.986 D	35	516 CDI (906.653, 906.655, 906.657) 03.2009 →	OM 651.957 D	36
519 CDI / BlueTEC 4x4 (906.153, 906.155, 906.253,...) 03.2009 →	OM 642.992 D	34	516 CDI 4x4 (906.653, 906.655, 906.657) 06.2006 →	OM 651.955 D	36



		Pos			Pos		
516 CDI 4x4 (906.653, 906.655, 906.657)	06.2006 →	OM 651.957 D	36	308 D 2.3	06.1989 → 06.1995	OM 601.940 D	83
518 CDI (906.653, 906.655, 906.657)	06.2006 → 12.2009	OM 642.896 D	34	308 D 2.3	05.1990 → 06.1995	OM 601.940 D	83
518 CDI (906.653, 906.655, 906.657)	06.2006 → 12.2009	OM 642.986 D	35	310 D 2.9	06.1989 → 02.1996	OM 602.940 D	82
518 CDI (906.653, 906.655, 906.657)	06.2006 → 12.2009	OM 642.992 D	34	310 D 2.9	06.1990 → 02.1996	OM 602.940 D	82
518 CDI (906.653, 906.655, 906.657)	06.2006 → 12.2009	OM 642.993 D	34	<b>T1 Bus (B601)</b>			
518 CDI 4x4 (906.653, 906.655, 906.657)	06.2006 → 12.2009	OM 642.896 D	34	207 D 2.4 (601.371, 601.372, 601.376, 601.377)	05.1977 → 12.1982	OM 616.917 D	102
518 CDI 4x4 (906.653, 906.655, 906.657)	06.2006 → 12.2009	OM 642.986 D	34	207 D 2.4 (601.371, 601.372, 601.376, 601.377)	05.1977 → 12.1982	OM 616.934 D	106
518 CDI 4x4 (906.653, 906.655, 906.657)	06.2006 → 12.2009	OM 642.986 D	34	207 D 2.4 (601.371, 601.376, 601.377)	07.1982 → 01.1990	OM 616.937 D	102
518 CDI 4x4 (906.653, 906.655, 906.657)	06.2006 → 12.2009	OM 642.986 D	35	207 D 2.4 (601.371, 601.376, 601.377)	09.1982 → 02.1989	OM 616.939 D	102
518 CDI 4x4 (906.653, 906.655, 906.657)	06.2006 → 12.2009	OM 642.992 D	34	208 2.3	05.1977 → 12.1982	M 115.955 B	117
518 CDI 4x4 (906.653, 906.655, 906.657)	06.2006 → 12.2009	OM 642.993 D	34	208 2.3	05.1977 → 12.1982	M 115.972 B	117
519 CDI / BlueTEC (906.653, 906.655, 906.657)	03.2009 →	OM 642.896 D	34	208 D 2.3	10.1988 → 06.1995	OM 601.940 D	83
519 CDI / BlueTEC (906.653, 906.655, 906.657)	03.2009 →	OM 642.898 D	34	208 D 2.3 (601.371, 601.372, 601.376, 601.377)	10.1988 → 06.1995	OM 601.940 D	83
519 CDI / BlueTEC (906.653, 906.655, 906.657)	03.2009 →	OM 642.986 D	35	209 D 2.9	12.1982 → 01.1989	OM 617.913 D	102
519 CDI / BlueTEC (906.653, 906.655, 906.657)	03.2009 →	OM 642.992 D	34	210 2.3	07.1982 → 12.1988	M 102.942 B	118
519 CDI / BlueTEC (906.653, 906.655, 906.657)	03.2009 →	OM 642.986 D	35	210 2.3	05.1989 → 02.1996	M 102.945 B	119
519 CDI / BlueTEC (906.653, 906.655, 906.657)	03.2009 →	OM 642.992 D	34	210 D 2.8	11.1988 → 02.1996	OM 602.940 D	82
519 CDI / BlueTEC (906.653, 906.655, 906.657)	03.2009 →	OM 642.986 D	35	210 D 2.8	11.1988 → 02.1996	OM 602.940 D	82
519 CDI / BlueTEC (906.653, 906.655, 906.657)	03.2009 →	OM 642.986 D	34	<b>T1 Platform/Chassis (601)</b>			
519 CDI / BlueTEC (906.653, 906.655, 906.657)	03.2009 →	OM 642.986 D	34	207 D 2.4	05.1977 → 08.1982	OM 616.917 D	102
519 CDI / BlueTEC (906.653, 906.655, 906.657)	03.2009 →	OM 642.896 D	34	207 D 2.4	09.1982 → 10.1989	OM 616.937 D	102
519 CDI / BlueTEC (906.653, 906.655, 906.657)	03.2009 →	OM 642.898 D	34	208 D 2.3	11.1988 → 06.1995	OM 601.940 D	83
519 CDI / BlueTEC (906.653, 906.655, 906.657)	03.2009 →	OM 642.898 D	34	208 D 2.3	06.1989 → 06.1995	OM 601.940 D	83
519 CDI / BlueTEC (906.653, 906.655, 906.657)	03.2009 →	OM 642.898 D	34	209 D 2.9	12.1982 → 01.1989	OM 617.913 D	102
519 CDI / BlueTEC (906.653, 906.655, 906.657)	03.2009 →	OM 642.898 D	34	210 2.3	04.1977 → 10.1989	M 115.955 B	117
519 CDI / BlueTEC (906.653, 906.655, 906.657)	03.2009 →	OM 642.898 D	34	210 2.3	07.1982 → 12.1988	M 102.942 B	118
519 CDI / BlueTEC (906.653, 906.655, 906.657)	03.2009 →	OM 642.986 D	35	210 D 2.8	11.1988 → 02.1996	OM 602.940 D	82
519 CDI / BlueTEC (906.653, 906.655, 906.657)	03.2009 →	OM 642.986 D	35	210 D 2.9	11.1988 → 02.1996	OM 602.940 D	82
524 (906.653, 906.655, 906.657)	06.2006 → 12.2013	M 272.979 B	112	<b>T1 Platform/Chassis (B602)</b>			
<b>SPRINTER 5-t Van (B907)</b>				307 D 2.4	09.1982 → 01.1983	OM 616.937 D	102
511 CDI (907.653, 907.655, 907.657)	02.2018 →	OM 651.958 D	45	307 D 2.4	09.1982 → 02.1989	OM 616.937 D	102
514 CDI (907.653, 907.655, 907.657)	02.2018 →	OM 651.958 D	45	307 D 2.4	09.1982 → 02.1989	OM 616.939 D	102
516 CDI (907.653, 907.655, 907.657)	02.2018 →	OM 651.958 D	45	308 D 2.3	06.1989 → 06.1995	OM 601.940 D	83
516 CDI All-wheel Drive (907.653, 907.655, 907.657)	01.2019 →	OM 651.958 D	45	308 D 2.3	06.1989 → 06.1995	OM 601.940 D	83
519 CDI (907.653, 907.655, 907.657)	02.2018 →	OM 642.899 D	34	309 D 3.0	10.1982 → 01.1989	OM 617.913 D	102
519 CDI All-wheel Drive (907.653, 907.655, 907.657)	01.2019 →	OM 642.899 D	34	310 2.3	01.1982 → 12.1994	M 102.942 B	118
<b>SPRINTER CLASSIC 3,5-t Van (B909)</b>				310 D 2.9	06.1989 → 02.1996	OM 602.940 D	82
311 CDI (909.632, 909.633)	09.2013 →	OM 646.701 D	72	310 D 2.9	06.1989 → 02.1996	OM 602.940 D	82
313 CDI (909.632, 909.633)	01.2017 →	OM 646.701 D	72	<b>T1 Van (601, 611)</b>			
<b>SPRINTER CLASSIC 4,6-t Bus (B909)</b>				207 D 2.4	09.1982 → 02.1989	OM 616.937 D	102
411 CDI (909.843)	09.2013 →	OM 646.701 D	72	207 D 2.4	09.1982 → 02.1989	OM 616.939 D	102
<b>SPRINTER CLASSIC 4,6-t Van (B909)</b>				208 D 2.3	10.1988 → 06.1995	OM 601.940 D	83
413 CDI (909.643)	01.2017 →	OM 646.701 D	72	208 D 2.3	11.1988 → 06.1995	OM 601.940 D	83
<b>SPRINTER Dump Truck (B905)</b>				209 D 2.9	12.1982 → 01.1989	OM 617.913 D	102
616 CDI (905.612, 905.622, 905.623)	04.2001 →	OM 612.981 D	71	210 2.3	05.1977 → 12.1982	M 115.955 B	117
<b>T1 Bus (602)</b>				210 2.3	07.1982 → 12.1988	M 102.942 B	118
				210 2.3	07.1982 → 12.1988	M 102.946 B	119
				210 2.3	05.1989 → 02.1996	M 102.945 B	119
				210 D 2.8	10.1988 → 02.1996	OM 602.940 D	82
				210 D 2.8	10.1988 → 02.1996	OM 602.940 D	82
				407 D 2.4 (611.367, 611.368)	04.1981 → 07.1982	OM 616.937 D	102
				<b>T1 Van (B602)</b>			
				307 D 2.4	10.1982 → 01.1990	OM 616.937 D	102
				307 D 2.4	10.1982 → 01.1990	OM 616.939 D	102
				308 D 2.3	11.1988 → 06.1995	OM 601.940 D	83
				308 D 2.3	06.1989 → 06.1995	OM 601.940 D	83
				309 D 3.0	10.1982 → 01.1989	OM 617.913 D	102
				310 2.3	01.1989 → 12.1995	M 102.945 B	119
				310 2.3	06.1989 → 02.1996	M 102.942 B	118
				310 D 2.9	06.1989 → 02.1996	OM 602.940 D	82
				310 D 2.9	06.1989 → 02.1996	OM 602.940 D	82

M

			Pos				Pos
T1/TN Platform/Chassis				T2/L Platform/Chassis			
407 D (611.317, 611.318)	07.1981 → 01.1989	OM 616.913	D	106	L 405 D	01.1972 → 12.1980	OM 615 D 59
407 D (611.317, 611.318)	07.1981 → 01.1989	OM 616.939	D	102	L 406 DG (309.100, 309.101, 309.102, 309.103)	01.1968 → 12.1974	OM 615.910 D 59
408 D (611.317, 611.318)	11.1988 → 06.1995	OM 601.940	D	83	L 407 D (309.100, 309.101, 309.102, 309.103)	01.1975 → 12.1988	OM 616.910 D 106
408 D (611.317, 611.318)	11.1988 → 06.1995	OM 601.940	D	83	L 407 D (309.100, 309.101, 309.102, 309.103)	01.1975 → 12.1988	OM 616.910 D 106
409 D (611.417, 611.418)	04.1982 → 01.1989	OM 617.913	D	102	L 407 D (309.100, 309.101, 309.102, 309.103)	05.1977 → 08.1982	OM 616.917 D 102
410 (611.017, 611.018)	08.1982 → 06.1995	M 102.942	B	118	L 408 DG (309.300, 309.301, 309.302, 309.303)	01.1970 → 12.1974	OM 314.948 D 131
410 (611.017, 611.018)	01.1989 → 06.1995	M 102.945	B	119	L 408 G (309.000, 309.001, 309.002, 309.003, 309.011)	08.1972 → 12.1974	M 115.928 B 58
410 D (611.417, 611.418)	11.1988 → 06.1995	OM 602.940	D	82	L 408 G (309.000, 309.001, 309.002, 309.003, 309.011, ...)	08.1972 → 12.1974	M 115.921 B 58
410 D (611.417, 611.418)	11.1988 → 06.1995	OM 602.940	D	82	L 409 (309.000, 309.001, 309.002, 309.003)	01.1975 → 08.1982	M 115.952 B 117
<b>T1/TN Van</b>				<b>T2/L Dump Truck</b>			
407 D (611.367, 611.368)	07.1981 → 01.1989	OM 616.913	D	106	L 608 D (310.340, 310.341, 310.342, 310.344, 310.345, ...)	02.1984 → 12.1988	OM 314.946 D 131
407 D (611.367, 611.368)	07.1981 → 01.1989	OM 616.939	D	102	L 608 D (310.340, 310.341, 310.342, 310.344, 310.345, ...)	02.1984 → 12.1988	OM 314.948 D 131
408 D (611.367, 611.368)	11.1988 → 06.1995	OM 601.940	D	83	L 608 D (310.340, 310.341, 310.342, 310.344, 310.345, ...)	02.1984 → 12.1988	OM 314.961 D 131
408 D (611.367, 611.368)	11.1988 → 06.1995	OM 601.940	D	83	L 608 D (310.340, 310.341, 310.342, 310.344, 310.345, ...)	02.1984 → 12.1988	OM 314.963 D 131
409 D (611.467, 611.468)	04.1982 → 01.1989	OM 617.913	D	102	L 608 D (310.340, 310.341, 310.342, 310.344, 310.345, ...)	02.1984 → 12.1988	OM 314.963 D 131
410 (611.067, 611.068)	08.1982 → 06.1995	M 102.942	B	118	L 608 G (309.040, 309.041)	01.1968 → 12.1974	M 115.921 B 58
410 (611.067, 611.068)	01.1989 → 06.1995	M 102.945	B	119	LK 408 G, LK 409 (309.040, 309.041, 309.044)	01.1975 → 08.1982	M 115.952 B 117
410 D (611.467, 611.468)	11.1988 → 06.1995	OM 602.940	D	82	LK 408 G, LK 409 (309.040, 309.041, 309.044)	01.1975 → 08.1982	M 115.952 B 117
410 D (611.467, 611.468)	11.1988 → 06.1995	OM 602.940	D	82	LK 408 G, LK 409 (309.040, 309.041, 309.044)	01.1975 → 08.1982	M 115.952 B 117
<b>T2/L Van</b>				<b>T2/L Van</b>			
L 608 D (310.340, 310.341, 310.342, 310.344, 310.345, ...)	02.1984 → 12.1988	OM 314.946	D	131	L 405 D	01.1972 → 12.1980	OM 615 D 59
L 608 D (310.340, 310.341, 310.342, 310.344, 310.345, ...)	02.1984 → 12.1988	OM 314.948	D	131	L 406 DG (309.111, 309.112, 309.113, 309.114, 309.115, ...)	01.1968 → 12.1974	OM 615.910 D 59
L 608 D (310.340, 310.341, 310.342, 310.344, 310.345, ...)	02.1984 → 12.1988	OM 314.961	D	131	L 407 D (309.111, 309.112, 309.113, 309.114, 309.115, ...)	01.1975 → 12.1988	OM 616.910 D 106
L 608 D (310.340, 310.341, 310.342, 310.344, 310.345, ...)	02.1984 → 12.1988	OM 314.963	D	131	L 407 D (309.111, 309.112, 309.113, 309.114, 309.115, ...)	01.1975 → 12.1988	OM 616.910 D 106
LK 408 G (309.040, 309.041)	01.1968 → 12.1974	M 115.921	B	58	L 408 DG (309.311, 309.312, 309.313, 309.314, 309.315, ...)	01.1970 → 12.1974	OM 314.948 D 131
LK 408 G, LK 409 (309.040, 309.041, 309.044)	01.1975 → 08.1982	M 115.952	B	117	L 408 G (309.012, 309.013, 309.014, 309.015, 309.016, ...)	01.1968 → 12.1972	M 115.I B 58
LK 408 G, LK 409 (309.040, 309.041, 309.044)	01.1975 → 08.1982	M 115.952	B	117	L 408 G (309.012, 309.013, 309.014, 309.015, 309.016, ...)	01.1968 → 12.1972	M 115.II B 58
LKO 508 DG (309.440, 309.441, 309.442, 309.444, 309.445)	09.1972 → 06.1988	OM 314.946	D	131	L 408 G (309.012, 309.013, 309.014, 309.015, 309.016, ...)	01.1968 → 12.1972	M 115.II B 58
LKO 508 DG (309.440, 309.441, 309.442, 309.444, 309.445)	09.1972 → 06.1988	OM 314.948	D	131	L 408 G (309.012, 309.013, 309.014, 309.015, 309.016, ...)	01.1968 → 12.1972	M 115.II B 58
LKO 508 DG (309.440, 309.441, 309.442, 309.444, 309.445)	09.1972 → 06.1988	OM 314.959	D	131	L 408 G (309.012, 309.013, 309.014, 309.015, 309.016, ...)	01.1968 → 12.1972	M 115.II B 58
LKO 508 DG (309.440, 309.441, 309.442, 309.444, 309.445)	09.1972 → 06.1988	OM 314.961	D	131	L 408 G (309.012, 309.013, 309.014, 309.015, 309.016, ...)	01.1968 → 12.1972	M 115.II B 58
LKO 508 DG (309.440, 309.441, 309.442, 309.444, 309.445)	09.1972 → 06.1988	OM 314.962	D	131	L 408 G (309.012, 309.013, 309.014, 309.015, 309.016, ...)	01.1968 → 12.1972	M 115.II B 58
LKO 508 DG (309.440, 309.441, 309.442, 309.444, 309.445)	09.1972 → 06.1988	OM 314.963	D	131	L 408 G (309.012, 309.013, 309.014, 309.015, 309.016, ...)	01.1968 → 12.1972	M 115.II B 58
LKO 508 DG (309.440, 309.441, 309.442, 309.444, 309.445)	09.1972 → 06.1988	OM 314.962	D	131	L 408 G (309.012, 309.013, 309.014, 309.015, 309.016, ...)	01.1968 → 12.1972	M 115.II B 58
LKO 508 DG (309.440, 309.441, 309.442, 309.444, 309.445)	09.1972 → 06.1988	OM 314.963	D	131	L 408 G (309.012, 309.013, 309.014, 309.015, 309.016, ...)	01.1968 → 12.1972	M 115.II B 58
LKO 508 DG (309.440, 309.441, 309.442, 309.444, 309.445)	09.1972 → 06.1988	OM 314.963	D	131	L 409 (309.011, 309.012, 309.013, 309.014, 309.015, ...)	01.1975 → 08.1982	M 115.952 B 117

		Pos			Pos	
L 410 (309.011, 309.012, 08.1982 → 12.1988 309.013, 309.014, 309.015,...	M 102.943	B	118	709 D (669.000, 669.001, 04.1986 → 12.1994 669.002, 669.003, 669.041)	OM 364.906 D	209
L 508 DG (309.411, 01.1970 → 12.1988 309.412, 309.413, 309.414, 309.415,...	OM 314.946	D	131	709 D (669.000, 669.001, 04.1986 → 12.1994 669.002, 669.003, 669.041)	OM 364.912 D	209
L 508 DG (309.411, 01.1970 → 12.1988 309.412, 309.413, 309.414, 309.415,...	OM 314.948	D	131	709 D (669.001, 669.002, 04.1986 → 12.1994 669.003, 669.041, 669.000)	OM 364.921 D	221
L 608 D (310.311, 01.1970 → 12.1988 310.312, 310.313, 310.314, 310.315,...	OM 314.948	D	131	711 D (669.301, 669.302, 04.1986 → 12.1994 669.303)	OM 364.950 D	210
L 608 D (310.311, 01.1970 → 12.1988 310.312, 310.313, 310.314, 310.315,...	OM 314.967	D	131	711 D (669.301, 669.302, 04.1986 → 12.1994 669.303)	OM 364.952 D	210
L 613 D (310.510, 04.1977 → 12.1988 313.424, 313.427, 313.429)	OM 353.963	D	130	711 D (669.301, 669.302, 02.1992 → 12.1994 669.303)	OM 364.957 D	212
L 613 D (310.510, 04.1977 → 12.1988 313.424, 313.427, 313.429)	OM 353.966	D	130	711 D (669.301, 669.302, 06.1994 → 12.1994 669.303)	OM 354.902 D	212
<b>T2/LN1 Bus</b>				711 D (669.301, 669.302, 06.1994 → 12.1994 669.303)	OM 354.903 D	212
O 609 D (672.072, 07.1987 → 12.1992 672.073)	OM 364.913	D	209	714 D (669.301, 669.302, 06.1994 → 12.1994 669.303)	OM 354.923 D	212
O 611 D (672.372, 07.1987 → 12.1992 672.373)	OM 364.952	D	210	809 D (670.001, 670.002, 04.1986 → 12.1994 670.003)	OM 364.906 D	209
O 611 D (672.372, 07.1987 → 12.1992 672.373)	OM 364.954	D	210	809 D (670.001, 670.002, 04.1986 → 12.1994 670.003)	OM 364.911 D	209
O 614 D (672.375, 07.1987 → 12.1992 672.376)	OM 364.980	D	224	809 D (670.001, 670.002, 02.1992 → 12.1994 670.003)	OM 364.920 D	221
O 614 D (672.375, 11.1987 → 12.1992 672.376)	OM 364.981	D	210	809 D (670.001, 670.002, 02.1992 → 12.1994 670.003)	OM 364.921 D	221
<b>T2/LN1 Dump Truck</b>				811 D (670.302, 04.1986 → 12.1994 670.303)	OM 364.950 D	210
507 DK (667.341, 04.1986 → 04.1989 667.342)	OM 616.914	D	106	811 D (670.302, 04.1986 → 12.1994 670.303)	OM 364.952 D	210
508 D (667.301, 667.302, 03.1989 → 12.1994 667.341, 667.342)	OM 601.941	D	83	811 D (670.303, 02.1992 → 12.1994 670.303)	OM 364.958 D	212
609 DK (668.041, 04.1986 → 12.1994 668.042)	OM 364.906	D	209	814 D (670.312, 11.1987 → 12.1994 670.313)	OM 354.924 D	212
609 DK (668.041, 07.1987 → 12.1994 668.042)	OM 364.919	D	221	814 D (670.312, 11.1987 → 12.1994 670.313)	OM 364.981 D	210
611 DK (668.041, 06.1994 → 12.1994 668.042)	OM 354.901	D	212	814 D (670.312, 02.1992 → 12.1994 670.313)	OM 364.986 D	212
709 DK (669.041, 04.1986 → 12.1994 669.042)	OM 364.906	D	209	814 DA 4x4 (670.411, 11.1987 → 12.1994 670.412)	OM 364.984 D	210
709 DK (669.041, 02.1992 → 12.1994 669.042)	OM 364.921	D	221	814 DA 4x4 (670.411, 11.1987 → 12.1994 670.412)	OM 364.987 D	212
809 DK (670.041, 04.1986 → 12.1994 670.042)	OM 364.906	D	209	814 DA 4x4 (670.411, 01.1991 → 12.1994 670.412)	OM 364.984 D	210
809 DK (670.041, 04.1986 → 12.1994 670.042)	OM 364.911	D	209	814 DA 4x4 (670.411, 02.1992 → 12.1994 670.412)	OM 364.987 D	212
809 DK (670.041, 02.1992 → 12.1994 670.042)	OM 364.920	D	221	<b>T2/LN1 Van</b>		
809 DK (670.041, 02.1992 → 12.1994 670.042)	OM 364.921	D	221	507 D (667.361, 04.1986 → 04.1989 667.362)	OM 616.914 D	106
811 DK (670.341, 04.1986 → 12.1994 670.342)	OM 364.950	D	210	508 D (667.361, 03.1989 → 12.1994 667.362)	OM 601.941 D	83
811 DK (670.341, 04.1986 → 12.1994 670.342)	OM 364.952	D	210	510 (667.061, 667.062) 04.1986 → 12.1994	M 102.946 B	119
<b>T2/LN1 Platform/Chassis</b>				510 (667.061, 667.062) 04.1986 → 12.1994	M 102.946 B	119
507 D (667.301, 667.302, 04.1986 → 04.1989 667.341, 667.342)	OM 616.914	D	106	609 D (668.061, 668.062, 04.1986 → 12.1994 668.063)	OM 364.906 D	209
510 (667.001, 667.002) 04.1986 → 12.1994	M 102.946	B	119	609 D (668.061, 668.062, 07.1987 → 12.1994 668.063)	OM 364.919 D	221
510 (667.001, 667.002) 04.1986 → 12.1994	M 102.946	B	119	609 D (668.061, 668.062, 06.1994 → 12.1994 668.063)	OM 354.902 D	212
609 D (668.001, 668.002, 04.1986 → 12.1994 668.003)	OM 364.906	D	209	611 D (668.061, 668.062, 06.1994 → 12.1994 668.063)	OM 354.901 D	212
609 D (668.001, 668.002, 07.1987 → 12.1994 668.003)	OM 364.919	D	221	709 D (669.061, 669.062, 04.1986 → 12.1994 669.063)	OM 364.906 D	209
609 D (668.001, 668.002, 06.1994 → 12.1994 668.003)	OM 354.902	D	212	709 D (669.061, 669.062, 04.1986 → 12.1994 669.063)	OM 364.912 D	209
611 D (668.001, 668.002, 06.1994 → 12.1994 668.003)	OM 354.902	D	212	709 D (669.061, 669.062, 02.1992 → 12.1994 669.063)	OM 364.921 D	221
				711 D (669.361, 669.362, 04.1986 → 12.1994 669.363)	OM 364.950 D	210

M

		Pos			Pos
711 D (669.361, 669.362, 04.1986 → 12.1994 669.363)	OM 364.952	D 210	V 300 CDI / d 4-matic (447.811, 447.813)	OM 654.920	D 27
711 D (669.361, 669.362, 02.1992 → 12.1994 669.363)	OM 364.957	D 212	V 300 CDI / d 4-matic (447811, 447813)	OM 654.920	D 27
711 D (669.361, 669.362, 06.1994 → 12.1994 669.363)	OM 354.902	D 212	<b>VARIO</b>		
711 D (669.361, 669.362, 06.1994 → 12.1994 669.363)	OM 354.903	D 212	614 D 2.9 09.1996 → 09.2013	OM 602.984	D 85
714 D (669.361, 669.362, 06.1994 → 12.1994 669.363)	OM 354.923	D 212	614 D 2.9 09.1996 → 09.2013	OM 602.985	D 85
809 D (670.061, 670.062, 04.1986 → 12.1994 670.063)	OM 364.906	D 209	810 D 2.9 09.1996 → 09.2013	OM 602.984	D 85
809 D (670.061, 670.062, 04.1986 → 12.1994 670.063)	OM 364.911	D 209	814 D 2.9 09.1996 → 09.2013	OM 602.985	D 85
809 D (670.061, 670.062, 02.1992 → 12.1994 670.063)	OM 364.920	D 221	814 D 2.9 09.1996 → 09.2013	OM 602.985	D 85
809 D (670.061, 670.062, 02.1992 → 12.1994 670.063)	OM 364.921	D 221	815 D 2.9 09.1996 → 09.2013	OM 602.984	D 85
811 D (670.362, 04.1986 → 12.1994 670.363)	OM 364.950	D 210	815 D 2.9 09.1996 → 09.2013	OM 602.985	D 85
811 D (670.362, 04.1986 → 12.1994 670.363)	OM 364.952	D 210	<b>VARIO Bus (B670)</b>		
811 D (670.362, 02.1992 → 12.1994 670.363)	OM 364.958	D 212	O 810 (670.373, 670.374)	OM 904.904	D 242
811 D (670.362, 06.1994 → 12.1994 670.363)	OM 354.901	D 212	O 812 (670.373, 670.674)	OM 602.984	D 85
811 D (670.362, 06.1994 → 12.1994 670.363)	OM 354.903	D 212	O 812 (670.373, 670.674)	OM 602.985	D 85
814 D (670.364, 670.365, 11.1987 → 12.1994 670.366)	OM 354.924	D 212	O 813 (670.373, 670.374)	OM 900.917	D 249
814 D (670.364, 670.365, 11.1987 → 12.1994 670.366)	OM 364.981	D 210	O 814 (670.373, 670.374)	OM 904.908	D 242
814 D (670.364, 670.365, 02.1992 → 12.1994 670.366)	OM 364.986	D 212	O 815 (670.373, 670.374)	OM 904.936	D 244
814 DA 4x4 (670.464, 01.1991 → 12.1994 670.465)	OM 364.984	D 210	O 815 (670.373, 670.374)	OM 904.923	D 242
814 DA 4x4 (670.464, 02.1992 → 12.1994 670.465)	OM 364.987	D 212	O 816 D (670.373, 670.374)	OM 900.918	D 249
<b>V-CLASS (638/2)</b>			O 818 D (670.373, 670.374)	OM 900.919	D 249
V 200 (638.214, 638.294) 02.1997 → 07.2003	M 111.948	B 93	<b>VARIO Dump Truck</b>		
V 200 (638.214, 638.294) 02.1997 → 07.2003	M 111.950	B 93	612 D (668.331, 668.332)	OM 602.984	D 85
V 200 CDI (638.294) 03.1999 → 07.2003	OM 611.980	D 69	612 D (668.331, 668.332)	OM 602.985	D 85
V 220 CDI (638.294) 03.1999 → 07.2003	OM 611.980	D 69	613 D, 614 D (668.331, 668.332)	OM 904.908	D 242
V 230 (638.234, 638.294) 10.1996 → 07.2003	M 111.978	B 100	613 D, 614 D (668.331, 668.332)	OM 900.917	D 249
V 230 (638.234, 638.294) 10.1996 → 07.2003	M 111.980	B 100	613 D, 614 D (668.331, 668.332)	OM 904.908	D 242
V 230 TD (638.274) 09.1996 → 07.2003	OM 601.970	D 87	615 D, 616 D (668.331, 668.332)	OM 900.918	D 249
V 280 (638.244, 638.294) 08.1997 → 07.2003	M 104.900	B 15	615 D, 616 D (668.331, 668.332)	OM 904.923	D 242
<b>V-CLASS (W447)</b>			615 D, 616 D (668.331, 668.332)	OM 904.923	D 242
V 200 CDI / d (447811, 03.2014 → 447813, 447815)	OM 651.950	D 41	618 D 09.2006 →	OM 900.919	D 249
V 200 CDI / d 4-matic 04.2015 →	OM 651.950	D 41	618 D 09.2006 →	OM 904.964	D 244
V 220 CDI / d (447811, 03.2014 → 447813, 447815)	OM 651.950	D 41	812 D (670.331, 670.332)	OM 602.984	D 85
V 220 CDI / d (447811, 03.2019 → 447813, 447815)	OM 654.920	D 27	812 D (670.331, 670.332)	OM 602.985	D 85
V 220 CDI / d 4-matic 03.2015 →	OM 651.950	D 41	813 D, 814 D (670.331, 670.332)	OM 900.917	D 249
V 220 CDI / d 4-matic 03.2019 → (447811, 447813)	OM 654.920	D 27	813 D, 814 D (670.331, 670.332)	OM 904.908	D 242
V 250 (447813, 447815) 03.2014 →	M 274.920	BG 29	813 D, 814 D (670.331, 670.332)	OM 904.908	D 242
V 250 BlueTEC / d (447811, 447813, 447815)	OM 651.950	D 41	813 DA, 814 DA 4x4 (670.431, 670.432)	OM 904.908	D 242
V 250 BlueTEC / d 12.2014 → 4-matic	OM 651.950	D 41	813 DA, 814 DA 4x4 (670.431, 670.432)	OM 904.908	D 242
V 250 CDI / d (447811, 03.2019 → 447813, 447815)	OM 654.920	D 27	815 D, 816 D (670.331, 670.332)	OM 900.918	D 249
V 250 CDI / d 4-matic 03.2019 → (447811, 447813)	OM 654.920	D 27	815 D, 816 D (670.331, 670.332)	OM 904.923	D 242
V 300 CDI / d (447.811, 01.2021 → 447.813, 447.815)	OM 654.920	D 27	815 D, 816 D (670.331, 670.332)	OM 904.923	D 242
V 300 CDI / d (447811, 03.2019 → 12.2020 447813, 447815)	OM 654.920	D 27			



		Pos			Pos
815 DA, 816 DA 4x4 (670.431, 670.432) 09.1996 → 12.2010	OM 904.923 D	242	818 DA 4x4 09.2006 →	OM 904.964 D	244
815 DA, 816 DA 4x4 (670.431, 670.432) 09.1996 → 12.2013	OM 904.923 D	242	<b>VARIO Van (B667, B670, B668)</b>		
818 D (670.321, 670.322) 09.2006 →	OM 900.919 D	249	512 D (667.351, 667.352, 09.1996 → 12.2010 667.353)	OM 602.984 D	85
818 D (670.321, 670.322) 09.2006 →	OM 904.964 D	244	612 D (668.351, 668.352, 09.1996 → 12.2010 668.353)	OM 602.984 D	85
818 DA 4x4 09.2006 →	OM 904.964 D	244	612 D (668.351, 668.352, 09.1996 → 12.2010 668.353)	OM 602.985 D	85
<b>VARIO Platform/Chassis (B670, B668, B667)</b>			613 D, 614 D (668.351, 09.1996 → 12.2011 668.352, 668.353)	OM 904.908 D	242
512 D (667.321, 667.322, 09.1996 → 12.2010 667.323)	OM 602.984 D	85	613 D, 614 D (668.351, 09.1996 → 12.2013 668.352, 668.353)	OM 900.917 D	249
612 D (668.321, 668.322, 09.1996 → 12.2010 668.323)	OM 602.984 D	85	613 D, 614 D (668.351, 09.1996 → 12.2013 668.352, 668.353)	OM 904.908 D	242
612 D (668.321, 668.322, 09.1996 → 12.2010 668.323)	OM 602.985 D	85	615 D, 616 D (668.351, 09.1998 → 668.352, 668.353)	OM 900.918 D	249
613 D, 614 D (668.321, 09.1996 → 12.2011 668.322, 668.323)	OM 904.908 D	242	615 D, 616 D (668.351, 09.1998 → 668.352, 668.353)	OM 904.923 D	242
613 D, 614 D (668.321, 09.1996 → 668.322, 668.323)	OM 904.908 D	242	615 D, 616 D (668.351, 09.1998 → 668.352, 668.353)	OM 904.923 D	242
613 D, 614 D (668.321, 09.1996 → 668.322, 668.323)	OM 904.917 D	242	618 D 09.2006 →	OM 900.919 D	249
615 D, 616 D (668.321, 09.1998 → 668.322, 668.323)	OM 900.918 D	249	618 D 09.2006 →	OM 904.964 D	244
615 D, 616 D (668.321, 09.1998 → 668.322, 668.323)	OM 904.923 D	242	812 D (670.351, 670.352, 09.1996 → 12.2010 670.353)	OM 602.984 D	85
615 D, 616 D (668.321, 09.1998 → 668.322, 668.323)	OM 904.923 D	242	812 D (670.351, 670.352, 09.1996 → 12.2010 670.353)	OM 602.985 D	85
618 D (668.321, 668.322, 09.2006 → 668.323)	OM 900.919 D	249	813 D, 814 D (670.351, 09.1996 → 12.2013 670.352, 670.353)	OM 900.917 D	249
618 D (668.321, 668.322, 09.2006 → 668.323)	OM 904.964 D	244	813 D, 814 D (670.351, 09.1996 → 12.2013 670.352, 670.353)	OM 904.908 D	242
812 D (670.321, 670.322, 09.1996 → 12.2010 670.323, 670.324)	OM 602.984 D	85	813 D, 814 D (670.351, 09.1996 → 12.2013 670.352, 670.353)	OM 904.908 D	242
812 D (670.321, 670.322, 09.1996 → 12.2010 670.323, 670.324)	OM 602.985 D	85	813 DA, 814 DA 4x4 09.1996 →	OM 904.908 D	242
813 D, 814 D (670.321, 09.1996 → 12.2013 670.322, 670.323, 670.324)	OM 900.917 D	249	(669.599, 670.451, 670.452, 670.453)		
813 D, 814 D (670.321, 09.1996 → 12.2013 670.322, 670.323, 670.324)	OM 904.908 D	242	813 DA, 814 DA 4x4 09.1996 →	OM 904.908 D	242
813 D, 814 D (670.321, 09.1996 → 12.2013 670.322, 670.323, 670.324)	OM 904.908 D	242	(669.599, 670.451, 670.452, 670.453)		
813 DA, 814 DA 4x4 (670.421, 670.422, 670.423) 09.1996 → 12.2013	OM 904.908 D	242	815 D, 816 D (670.351, 09.1996 → 12.2010 670.352, 670.353)	OM 904.923 D	242
813 DA, 814 DA 4x4 (670.421, 670.422, 670.423) 09.1996 → 12.2013	OM 904.908 D	242	815 D, 816 D (670.351, 09.1996 → 12.2013 670.352, 670.353)	OM 900.918 D	249
815 D (670.324, 670.323, 09.1996 → 12.2013 670.322, 670.321)	OM 904.936 D	244	815 D, 816 D (670.351, 09.1996 → 12.2013 670.352, 670.353)	OM 904.923 D	242
815 D, 816 D (670.321, 09.1996 → 12.2010 670.322, 670.323, 670.324)	OM 904.923 D	242	815 DA, 816 DA 4x4 09.1996 → 12.2010	OM 904.923 D	242
815 D, 816 D (670.321, 09.1996 → 12.2013 670.322, 670.323, 670.324)	OM 900.918 D	249	(669.599, 670.451, 670.452, 670.453)		
815 DA, 816 DA 4x4 (670.421, 670.422, 670.423) 09.1996 → 12.2010	OM 904.923 D	242	815 DA, 816 DA 4x4 09.1996 → 12.2013	OM 904.923 D	242
815 DA, 816 DA 4x4 (670.421, 670.422, 670.423) 09.1996 → 12.2013	OM 904.923 D	242	(669.599, 670.451, 670.452, 670.453)		
818 D (670.321, 670.322, 09.2006 → 670.323, 670.324)	OM 900.919 D	249	818 D (670.351, 670.352, 09.2006 → 670.353)	OM 900.919 D	249
818 D (670.321, 670.322, 09.2006 → 670.323, 670.324)	OM 904.964 D	244	818 D (670.351, 670.352, 09.2006 → 670.353)	OM 904.964 D	244
			<b>VIANO (V639/W639)</b>		
			3.0 09.2003 →	M 112.951 B	95
			<b>VIANO (W639)</b>		
			3.0 (639.711, 639.811) 09.2003 →	M 112.951 B	95
			3.2 (639.713, 639.813, 09.2003 → 639.815)	M 112.951 B	95
			3.5 (639.811, 639.813, 09.2007 → 639.815)	M 272.978 B	111
			3.7 (639.811, 639.813, 06.2004 → 07.2007 639.815)	M 112.976 B	127
			3.7 (639.815) 06.2004 →	M 112.976 B	127
			CDI 2.0 (639.711, 09.2003 → 639.713, 639.811, 639.813, 639.815)	OM 646.982 D	74
			CDI 2.0 (639.711, 08.2005 → 639.713, 639.811, 639.813, 639.815)	OM 646.982 D	74

M



		Pos			Pos		
CDI 2.0 (639.811, 639.813, 639.815)	07.2010 →	OM 651.940 D	36	123 (639.601)	06.2004 → 07.2008	M 112.976 B	127
CDI 2.0 4-matic (639.711, 639.713, 639.811, 639.813,....)	03.2006 →	OM 646.982 D	74	123 (639.601, 639.603, 639.605)	06.2004 → 07.2008	M 112.976 B	127
CDI 2.0 4-matic (639.713)	07.2005 →	OM 646.982 D	74	126 (639.601, 639.603, 639.605)	09.2007 →	M 272.978 B	111
CDI 2.0 4-matic (639.811, 639.813, 639.815)	07.2010 →	OM 651.940 D	36	<b>VITO Bus (W638)</b>			
CDI 2.2 (639.711, 639.713, 639.811, 639.813, 639.815)	09.2003 →	OM 646.980 D	72	108 CDI 2.2 (638.194)	03.1999 → 07.2003	OM 611A (60 KW D CDI)	68
CDI 2.2 (639.711, 639.713, 639.811, 639.813, 639.815)	09.2003 →	OM 646.982 D	74	108 D 2.3 (638.164)	02.1996 → 07.2003	OM 601.942 D	83
CDI 2.2 (639.811, 639.813, 639.815)	07.2010 →	OM 651.940 D	36	110 CDI 2.2 (638.194)	03.1999 → 07.2003	OM 611LA (75 KW D CDI)	68
CDI 2.2 (639.711, 639.713, 639.811, 639.813, 639.815)	09.2003 →	OM 646.982 D	74	110 TD 2.3 (638.174)	02.1996 → 07.2003	OM 601.970 D	87
CDI 2.2 (639.811, 639.813, 639.815)	01.2014 →	OM 651.940 D	36	112 CDI 2.2 (638.194)	03.1999 → 07.2003	OM 611.980 D	69
CDI 2.2 4-matic (639.711, 639.713, 639.811, 639.813, 639.815)	07.2005 →	OM 646.982 D	74	113 2.0 (638.114, 638.194)	02.1996 → 07.2003	M 111.948 B	93
CDI 2.2 4-matic (639.811, 639.813, 639.815)	07.2010 →	OM 651.940 D	36	113 2.0 (638.114, 638.194)	02.1996 → 07.2003	M 111.950 B	93
CDI 2.2 4-matic (639.811, 639.813, 639.815)	01.2014 →	OM 651.940 D	36	114 2.3 (638.134, 638.194)	12.1996 → 07.2003	M 111.978 B	100
CDI 2.2 4-matic (639.711, 639.713, 639.811, 639.813, 639.815)	07.2005 →	OM 646.982 D	74	114 2.3 (638.134, 638.194)	12.1996 → 07.2003	M 111.980 B	100
CDI 2.2 4-matic (639.811, 639.813, 639.815)	07.2010 →	OM 651.940 D	36	<b>VITO Bus (W639)</b>			
CDI 3.0 (639.811, 639.813, 639.815)	03.2006 →	OM 642.990 D	34	109 CDI (639.701)	09.2003 →	OM 646.983 D	74
CDI 3.0 (639.811, 639.813, 639.815)	07.2010 →	OM 642.890 D	34	109 CDI (639.701, 639.703)	09.2006 →	OM 646.980 D	72
<b>VITO / MIXTO Van (W639)</b>				109 CDI 4x4 (639.701)	09.2007 → 08.2014	OM 646.981 D	72
109 CDI (639.601, 639.603, 639.605)	09.2003 →	OM 646.983 D	74	110 CDI (639.701, 639.703, 639.705)	09.2010 → 08.2014	OM 651.940 D	36
109 CDI (639.601, 639.603, 639.605)	08.2006 →	OM 646.980 D	72	111 CDI (639.701, 639.703, 639.705)	09.2003 →	OM 646.982 D	74
109 CDI (639.601, 639.603, 639.605)	08.2006 →	OM 646.981 D	72	111 CDI (639.701, 639.703, 639.705)	09.2007 →	OM 646.980 D	72
110 CDI (639.601, 639.603, 639.605)	09.2010 →	OM 651.940 D	36	111 CDI 4x4 (639.701, 639.703, 639.705)	09.2007 → 08.2014	OM 646.982 D	74
111 CDI (639.601, 639.603)	09.2007 →	OM 646.980 D	72	113 CDI (639.701, 639.703, 639.705)	09.2010 →	OM 651.940 D	36
111 CDI (639.601, 639.603)	09.2007 →	OM 646.982 D	74	113 CDI 4x4 (639.701, 639.703, 639.705)	09.2010 → 08.2014	OM 651.940 D	36
111 CDI (639.601, 639.603, 639.605)	09.2003 →	OM 646.982 D	74	115 CDI (639.701, 639.703, 639.705)	09.2003 →	OM 646.980 D	72
111 CDI (639.601, 639.603, 639.605)	09.2007 →	OM 646.982 D	74	115 CDI (639.701, 639.703, 639.705)	09.2003 →	OM 646.982 D	74
111 CDI (639.601, 639.603, 639.605)	09.2003 →	OM 646.982 D	74	115 CDI (639.701, 639.703, 639.705)	05.2012 → 02.2015	OM 651.940 D	36
111 CDI (639.601, 639.603, 639.605)	05.2012 → 02.2015	OM 651.940 D	36	115 CDI 4x4 (639.701, 639.703, 639.705)	09.2007 → 08.2014	OM 646.982 D	74
111 CDI 4x4 (639.601, 639.603, 639.605)	09.2007 →	OM 646.982 D	74	116 CDI (639.701, 639.703, 639.705)	09.2010 →	OM 651.940 D	36
113 CDI (639.601, 639.603, 639.605)	09.2010 →	OM 651.940 D	36	116 CDI 4x4 (639.701, 639.703, 639.705)	09.2010 → 08.2014	OM 651.940 D	36
113 CDI 4x4 (639.601, 639.603, 639.605)	09.2010 →	OM 651.940 D	36	119 (639.701, 639.703, 639.705)	09.2003 →	M 112.951 B	95
115 CDI (639.601, 639.603, 639.605)	09.2003 →	OM 646.980 D	72	120 CDI (639.701, 639.703, 639.705)	07.2006 →	OM 642.990 D	34
115 CDI (639.601, 639.603, 639.605)	09.2003 →	OM 646.982 D	74	122 (639.701, 639.703, 639.705)	09.2003 →	M 112.951 B	95
115 CDI (639.605, 639.601, 639.603)	05.2012 → 02.2015	OM 651.940 D	36	122 CDI (639.701, 639.703, 639.705)	09.2010 →	OM 642.890 D	34
115 CDI 4x4 (639.601, 639.603, 639.605)	07.2006 →	OM 646.982 D	74	123 (639.701)	06.2004 → 07.2008	M 112.976 B	127
116 CDI (639.601, 639.603, 639.605)	09.2010 →	OM 651.940 D	36	123 (639.701, 639.703, 639.705)	06.2004 → 07.2008	M 112.976 B	127
116 CDI 4x4 (639.601, 639.603, 639.605)	09.2010 →	OM 651.940 D	36	126 (639.701, 639.703, 639.705)	09.2007 →	M 272.978 B	111
119 (639.601, 639.603, 639.605)	09.2003 →	M 112.951 B	95	<b>VITO Mixto (Double Cabin) (W447)</b>			
120 CDI (639.601, 639.603, 639.605)	07.2006 →	OM 642.990 D	34	109 CDI (447.701, 447.703, 447.705)	10.2014 →	OM 622.951 D	13
122 (639.601, 639.603, 639.605)	09.2003 →	M 112.951 B	95	111 CDI (447.701, 447.703, 447.705)	10.2014 →	OM 622.951 D	13
122 CDI (639.601, 639.603, 639.605)	09.2010 →	OM 642.890 D	34	114 CDI (447.701, 447.703, 447.705)	10.2014 →	OM 651.950 D	41
				114 CDI (447.701, 447.703, 447.705)	03.2019 →	OM 654.920 D	27



		Pos			Pos
1115	OM 366.941 D	190	1313	OM 352.916 D	133
1115	OM 366.942 D	190	1313	OM 352.917 D	129
1115	OM 366.943 D	190	1313	OM 352.944 D	129
1115	OM 376.909 D	185	1313	OM 352.948 D	129
1115	OM 904.925 D	240	1313	OM 352.953 D	129
1116	06.1973 → OM 344.937 D	144	1313	OM 352.954 D	129
1116	06.1973 → OM 344.942 (USA) D	145	1313	OM 352.955 D	129
1116	06.1973 → OM 344.950 (USA) D	146	1313	OM 352.992 D	129
1116	06.1973 → OM 366.941 D	190	1313	OM 376.909 D	185
1116	06.1973 → OM 366.942 D	190	1313	1965 → 12.1967 OM 327.940 D	321
1116	06.1973 → OM 366.943 D	190	1313	1965 → 1968 OM 327.918 D	321
1116	09.1973 → OM 344.913 D	144	1313	1965 → 1968 OM 327.919 D	321
1118	06.1973 → OM 344.954 D	144	1313	1965 → 1968 OM 327.941 D	321
1118	06.1973 → OM 344.955 D	144	1313	1965 → 1968 OM 327.943 D	321
1118	06.1973 → OM 352.916 D	133	1313	1965 → 1968 OM 327.944 D	321
1119	OM 366.941 D	190	1313	1965 → 1968 OM 327.945 D	321
1119	OM 366.942 D	190	1313	1965 → 1968 OM 327.946 D	321
1119	OM 366.943 D	190	1313	09.1965 → 12.1966 OM 352.987 D	129
1119	OM 924.929 D	283	1313	09.1965 → OM 352.964 D	129
1121	04.1984 → 12.1992 OM 366.962 D	195	1313	01.1967 → 02.2001 OM 352.938 D	130
1121	04.1984 → OM 390.900-508 (AMS) D	189	1313	01.1967 → OM 352.963 D	130
1121	02.1992 → OM 366.941 D	190	1313	01.1967 → OM 352.991 D	129
1121	02.1992 → OM 366.941 D	190	1313	10.1967 → 03.1977 OM 352.905 D	129
<b>12T-SERIES</b>			1313	1968 → 1977 OM 360.937 D	321
1215	OM 372.907 D	185	1313	1968 → 1977 OM 360.938 D	321
1215	OM 372.953 D	190	1313	1968 → 1977 OM 360.962 D	321
1215	OM 376.907 D	185	1313	03.1968 → 03.1977 OM 352.968 D	133
1215	OM 376.909 D	185	1313	05.1969 → 05.1971 OM 360.935 D	321
1215	OM 376.930 D	185	1313	05.1969 → 05.1971 OM 360.936 D	321
1215	OM 904.925 D	240	1313	05.1969 → 05.1971 OM 360.951 D	321
1215	OM 904.943 D	240	1313	05.1969 → 05.1971 OM 360.952 D	321
1215	OM 906.985 D	241	1313	01.1970 → 03.1977 OM 353.909 D	133
1216	01.1965 → 04.1969 OM 327.942 D	321	1313	01.1972 → 07.1983 OM 353.911 D	141
1216	01.1967 → 12.1967 OM 327.916 D	321	1313	01.1972 → 02.2001 OM 353.913 D	141
1216	09.1967 → 04.1969 OM 327.933 D	321	1313	01.1972 → OM 353.912 D	141
1216	1968 → 1977 OM 360.939 D	321	1313	01.1972 → OM 353.914 D	141
1216	1968 → 1977 OM 360.944 D	321	1313	06.1973 → OM 344.937 D	144
1216	1968 → 1977 OM 360.946 D	321	1313	06.1973 → OM 344.951 D	144
1216	1968 → 1977 OM 360.949 D	321	1313	09.1973 → OM 344.939 D	144
1216	1968 → 1977 OM 360.950 D	321	1313	09.1973 → OM 352.994 D	133
1216	1968 → 1977 OM 360.961 D	321	1313	01.1975 → OM 352.997 D	130
1216	1968 → 1977 OM 360.964 D	321	1315	OM 372.906 D	185
1216	1968 → 1977 OM 360.965 D	321	1315	OM 376.908 D	185
1216	1968 → 1977 OM 360.972 D	321	1315	OM 376.909 D	185
1218	05.1988 → OM 366.941 D	190	1316	OM 904.925 D	240
1218	05.1988 → OM 366.942 D	190	1316	06.1973 → M 372.924 G	183
1218	05.1988 → OM 366.943 D	190	1316	06.1973 → M 372.926 G	184
1218	05.1988 → OM 372.962 D	190	1316	06.1973 → OM 344.905 D	134
1218	05.1988 → OM 376.945 D	186	1316	06.1973 → OM 344.937 D	144
1218	05.1988 → OM 376.950 D	186	1316	06.1973 → OM 344.942 (USA) D	145
1218	05.1988 → OM 376.955 D	186	1316	06.1973 → OM 344.951 D	144
1218	05.1988 → OM 376.956 D	186	1316	06.1973 → OM 344.991 D	134
1218	05.1988 → OM 377.940 D	187	1316	06.1973 → OM 352.900-016 D	135
1218	05.1988 → OM 904.938 D	240	1316	06.1973 → OM 352.904 D	129
1218	05.1988 → OM 904.943 D	240	1316	06.1973 → OM 352.915 D	129
1218	05.1988 → OM 906.985 D	241	1316	06.1973 → OM 352.916 D	133
1218	07.1998 → OM 904.912 D	240	1316	06.1973 → OM 352.917 D	129
1245	01.1985 → 02.1991 OM 442.953 D	390	1316	06.1973 → OM 352.944 D	129
<b>13T-SERIES</b>			1316	06.1973 → OM 352.948 D	129
1313	01.1964 → 1981 OM 352.939 D	129	1316	06.1973 → OM 352.953 D	129
1313	01.1964 → OM 344.905 D	134	1316	06.1973 → OM 352.954 D	129
1313	01.1964 → OM 344.946 D	134	1316	06.1973 → OM 352.955 D	129
1313	01.1964 → OM 344.963 D	134	1316	06.1973 → OM 352.987 D	129
1313	01.1964 → OM 344.991 D	134	1316	06.1973 → OM 352.991 D	129
1313	01.1964 → OM 344.997 D	134	1316	06.1973 → OM 352.992 D	129
1313	01.1964 → OM 352.900-016 D	135	1316	06.1973 → OM 366.941 D	190
1313	01.1964 → OM 352.904 D	129	1316	06.1973 → OM 366.942 D	190
1313	01.1964 → OM 352.908 D	130	1316	06.1973 → OM 366.943 D	190
1313	01.1964 → OM 352.915 D	129	1316	06.1973 → OM 372.906 D	185

M

				Pos					Pos
1316	06.1973 →	OM 372.930	D	198	1418	01.1966 →	OM 377.940	D	187
1316	06.1973 →	OM 372.950	D	190	1418	01.1966 →	OM 377.941	D	187
1316	09.1973 →	OM 344.938	D	144	1418	01.1966 →	OM 904.938	D	240
1316	09.1973 →	OM 344.939	D	144	1418	01.1966 →	OM 904.945	D	240
1318	06.1973 →	OM 341.947	D	143	1418	01.1966 →	OM 904.962	D	240
1318	06.1973 →	OM 344.937	D	144	1418	01.1966 →	OM 904.968	D	240
1318	06.1973 →	OM 344.954	D	144	1418	01.1966 →	OM 906.985	D	241
1318	06.1973 →	OM 344.955	D	144	1418	06.1973 →	OM 341.947	D	143
1318	06.1973 →	OM 352.900-016	D	135	1418	05.1988 →	OM 376.955	D	186
1318	06.1973 →	OM 352.904	D	129	1418	05.1988 →	OM 376.956	D	186
1318	06.1973 →	OM 352.915	D	129	1418	05.1988 →	OM 376.962	D	186
1318	06.1973 →	OM 352.916	D	133	1418	07.1998 →	OM 904.912	D	240
1318	06.1973 →	OM 352.917	D	129	1421		OM 366.995	D	190
1318	06.1973 →	OM 352.944	D	129	1421		OM 372.983	D	193
1318	06.1973 →	OM 352.948	D	129	1421		OM 372.984	D	193
1318	06.1973 →	OM 352.953	D	129	1421		OM 376.941	D	193
1318	06.1973 →	OM 352.954	D	129	1421		OM 377.981	D	187
1318	06.1973 →	OM 352.955	D	129	1421		OM 390.900-549	D	189
1318	06.1973 →	OM 352.987	D	129	1423		OM 902.920	D	238
1318	06.1973 →	OM 352.991	D	129	1423		OM 906.932	D	241
1318	06.1973 →	OM 352.992	D	129	1423		OM 906.966	D	241
1318	06.1973 →	OM 366.941	D	190	1423		OM 924.915	D	290
1318	06.1973 →	OM 366.942	D	190	1442	01.1988 →	OM 442.907	D	504
1318	06.1973 →	OM 366.943	D	190	<b>15T-SERIES</b>				
1318	06.1973 →	OM 372.959	D	190	1513	01.1964 → 1981	OM 352.935	D	129
1318	06.1973 →	OM 376.967	D	186	1513	01.1964 → 02.2001	OM 344.963	D	134
1318	06.1973 →	OM 376.970	D	191	1513	01.1964 → 02.2001	OM 352.900-016	D	135
1318	06.1973 →	OM 376.977	D	191	1513	01.1964 → 02.2001	OM 352.904	D	129
1318	06.1973 →	OM 376.995	D	191	1513	01.1964 → 02.2001	OM 352.908	D	130
1318	06.1973 →	OM 377.942	D	187	1513	01.1964 → 02.2001	OM 352.915	D	129
1318	06.1973 →	OM 377.943	D	187	1513	01.1964 → 02.2001	OM 352.917	D	129
1318	06.1973 →	OM 377.944	D	197	1513	01.1964 → 02.2001	OM 352.944	D	129
1318	06.1973 →	OM 377.945	D	187	1513	01.1964 → 02.2001	OM 352.948	D	129
1318	06.1973 →	OM 904.938	D	240	1513	01.1964 → 02.2001	OM 352.953	D	129
1318	06.1973 →	OM 904.943	D	240	1513	01.1964 → 02.2001	OM 352.954	D	129
1318	06.1973 →	OM 906.985	D	241	1513	01.1964 → 02.2001	OM 352.955	D	129
1318	05.1988 →	OM 372.956	D	190	1513	01.1964 → 02.2001	OM 352.987	D	129
1318	05.1988 →	OM 376.951	D	186	1513	01.1964 → 02.2001	OM 352.991	D	129
1318	05.1988 →	OM 376.952	D	186	1513	01.1964 → 02.2001	OM 352.992	D	129
1318	05.1988 →	OM 376.953	D	186	1513	01.1967 → 03.1977	OM 352.930	D	129
1318	05.1988 →	OM 376.954	D	186	1513	10.1967 → 03.1977	OM 352.912	D	129
1319	12.1985 →	OM 366.941	D	190	1513	10.1969 → 08.1983	OM 352.936	D	130
1319	12.1985 →	OM 366.942	D	190	1513	1971 → 1982	OM 352.913	D	133
1319	12.1985 →	OM 366.943	D	190	1513	1971 → 02.2001	OM 352.937	D	133
1319	12.1985 →	OM 372.950	D	190	1513	01.1972 → 03.1977	OM 353.910	D	133
1319	12.1985 →	OM 376.967	D	186	1513	01.1972 → 02.2001	OM 353.912	D	141
1319	12.1985 →	OM 376.981	D	219	1513	01.1980 → 02.2001	OM 353.939	D	164
1319	12.1985 →	OM 376.988	D	219	1516	09.1973 →	OM 344.938	D	144
1319	12.1985 →	OM 376.998	D	219	1516	09.1973 →	OM 352.900-016	D	135
1319	12.1985 →	OM 377.942	D	187	1516	09.1973 →	OM 352.904	D	129
1319	12.1985 →	OM 924.929	D	283	1516	09.1973 →	OM 352.915	D	129
1319	05.1988 →	OM 372.956	D	190	1516	09.1973 →	OM 352.916	D	133
1321		OM 390.900-508 (AMS)	D	189	1516	09.1973 →	OM 352.917	D	129
<b>14T-SERIES</b>					1516	09.1973 →	OM 352.944	D	129
1416	01.1965 → 1968	OM 327.910	D	321	1516	09.1973 →	OM 352.948	D	129
1418	01.1966 → 12.1973	OM 346.914	D	361	1516	09.1973 →	OM 352.953	D	129
1418	01.1966 → 12.1973	OM 346.915	D	361	1516	09.1973 →	OM 352.954	D	129
1418	01.1966 → 12.1973	OM 346.946	D	361	1516	09.1973 →	OM 352.955	D	129
1418	01.1966 → 12.1973	OM 346.953	D	361	1516	09.1973 →	OM 352.987	D	129
1418	01.1966 →	OM 345.900	D	363	1516	09.1973 →	OM 352.991	D	129
1418	01.1966 →	OM 345.947	D	363	1516	09.1973 →	OM 352.992	D	129
1418	01.1966 →	OM 366.941	D	190	1516	09.1973 →	OM 366.941	D	190
1418	01.1966 →	OM 366.942	D	190	1516	09.1973 →	OM 366.942	D	190
1418	01.1966 →	OM 366.942	D	190	1516	09.1973 →	OM 366.943	D	190
1418	01.1966 →	OM 366.943	D	190	1518	01.1966 → 12.1973	OM 346.916	D	361
1418	01.1966 →	OM 372.961	D	190	1518	01.1966 →	OM 345.941	D	363
1418	01.1966 →	OM 376.945	D	186	1518	01.1966 →	OM 345.942	D	364
1418	01.1966 →	OM 376.969	D	191	1518	01.1966 →	OM 352.900-016	D	135
1418	01.1966 →	OM 376.976	D	191	1518	01.1966 →	OM 352.904	D	129

M



# MERCEDES-BENZ

			Pos				Pos		
1518	01.1966 →	OM 352.915	D	129	1621	09.1969 →	OM 372.983	D	193
1518	01.1966 →	OM 352.916	D	133	1621	09.1969 →	OM 372.984	D	193
1518	01.1966 →	OM 352.917	D	129	1621	09.1969 →	OM 372.985	D	193
1518	01.1966 →	OM 352.944	D	129	1621	09.1969 →	OM 372.986	D	194
1518	01.1966 →	OM 352.948	D	129	1621	09.1969 →	OM 372.987	D	193
1518	01.1966 →	OM 352.953	D	129	1621	09.1969 →	OM 376.941	D	193
1518	01.1966 →	OM 352.954	D	129	1621	09.1969 →	OM 376.968	D	191
1518	01.1966 →	OM 352.955	D	129	1621	09.1969 →	OM 376.975	D	191
1518	01.1966 →	OM 352.987	D	129	1621	09.1969 →	OM 377.981	D	187
1518	01.1966 →	OM 352.991	D	129	1621	09.1969 →	OM 390.900-512	D	189
1518	01.1966 →	OM 352.992	D	129	1621	09.1969 →	OM 390.900-515	D	189
1518	01.1966 →	OM 366.941	D	190	1621	09.1969 →	OM 390.900-518	D	189
1518	01.1966 →	OM 366.942	D	190	1621	09.1969 →	OM 390.900-521	D	189
1518	01.1966 →	OM 366.943	D	190	1621	06.1978 →	OM 360.982	D	321
1518	01.1966 →	OM 904.938	D	240	1621	05.1988 →	OM 376.986	D	220
1518	06.1973 →	OM 341.937	D	143	1623	01.1964 → 1967	OM 346.912	D	361
1518	06.1973 →	OM 344.955	D	144	1623	01.1964 →	M 376.922	G	182
1518	09.1973 →	OM 344.938	D	144	1623	01.1964 →	OM 377.962	D	187
1518	05.1988 →	OM 386.950	D	196	1623	01.1964 →	OM 902.920	D	238
1518	05.1988 →	OM 386.951	D	196	1623	01.1964 →	OM 906.999	D	239
1519	06.1971 → 12.1976	OM 360.940	D	321	1623	04.1991 →	OM 306.900-510	D	227
1519	06.1971 → 12.1976	OM 360.941	D	321		(ZA)			
1519	06.1971 → 12.1976	OM 360.948	D	321	1626	04.1972 → 1985	OM 402.924	D	327
1519	06.1971 →	OM 372.951	D	190	1626	04.1972 → 12.1985	OM 906.988	D	241
1519	06.1971 →	OM 924.925	D	281	1626	04.1972 → 12.1985	OM 906.999	D	239
1519	05.1984 → 04.1987	OM 345.915	D	363	1626	04.1972 → 12.1985	OM 926.950	D	282
1521	07.1985 →	OM 341.915	D	137	1626	05.1972 → 12.1974	OM 402.905	D	327
1521	07.1985 →	OM 347.915	D	396	1626	08.1973 → 12.1980	CO 3 D VAR.1	D	315
1521	07.1985 →	OM 372.987	D	193	1626	05.1974 → 12.1980	OM 402.912	D	327
1521	07.1985 →	OM 377.968	D	187	1626	06.1975 → 12.1980	OM 402.916	D	327
1521	07.1985 →	OM 377.985	D	187	1627	08.1988 → 09.1993	OM 442.926	D	504
1521	07.1985 →	OM 377.986	D	189	1627	08.1992 →	OM 401.984	D	336
1521	07.1985 →	OM 386.980	D	196	1627	08.1992 →	OM 440.907	D	503
1521	07.1985 →	OM 386.981	D	196	1627	01.1994 →	OM 445.934	D	372
1521	07.1985 →	OM 386.983	D	196	1627	01.1995 →	OM 445.935	D	372
1521	07.1985 →	OM 390.900-505	D	189	1627	07.1995 →	OM 441.986	D	418
		(AMS)			1630		OM 475.982	D	417
1521	07.1985 →	OM 390.900-506	D	189	1630		OM 475.985	D	417
1522		OM 347.942	D	396	1630		OM 475.989	D	417
1525	01.1985 → 12.2001	OM 429.951	D	393	1634	01.1992 →	OM 440.945	D	371
1525	01.1985 → 12.2001	OM 429.953	D	394	1634	01.1995 →	OM 445.934	D	372
1525	01.1985 → 12.2001	OM 429.955	D	395	1634	11.1995 →	OM 476.971	D	401
1525	01.1985 →	OM 345.970 (BRA)	D	368	1650	01.1984 → 1989	OM 423.950	D	387
1526		OM 347.917	D	368	<b>17T-SERIES</b>				
1526		OM 347.970	D	368	1713	01.1964 → 1981	OM 352.931	D	129
1526		OM 352.908	D	130	1714		OM 376.907	D	185
1526		OM 906.998	D	266	1714		OM 376.930	D	185
1551	07.1985 →	OM 386.981	D	196	1715		OM 376.930	D	185
1560	07.1985 →	OM 377.968	D	187	1718	05.1988 →	OM 366.941	D	190
1560	07.1985 →	OM 377.985	D	187	1718	05.1988 →	OM 366.942	D	190
1560	07.1985 →	OM 386.981	D	196	1718	05.1988 →	OM 366.943	D	190
<b>16T-SERIES</b>					1718	05.1988 →	OM 372.961	D	190
1615		OM 372.907	D	185	1718	05.1988 →	OM 376.945	D	186
1615		OM 372.953	D	190	1718	05.1988 →	OM 376.955	D	186
1615		OM 376.907	D	185	1718	05.1988 →	OM 376.956	D	186
1618	01.1966 → 12.1973	OM 346.914	D	361	1718	05.1988 →	OM 377.941	D	187
1618	01.1966 →	OM 366.941	D	190	1718	05.1988 →	OM 904.938	D	240
1618	01.1966 →	OM 366.942	D	190	1718	05.1988 →	OM 904.943	D	240
1618	01.1966 →	OM 366.943	D	190	1718	05.1988 →	OM 906.985	D	241
1618	01.1966 →	OM 376.945	D	186	1721	05.1988 →	OM 372.985	D	193
1618	01.1966 →	OM 904.938	D	240	1721	05.1988 →	OM 376.984	D	220
1618	05.1988 →	OM 376.955	D	186	1721	05.1988 →	OM 376.986	D	220
1618	05.1988 →	OM 376.964	D	186	1721	05.1988 →	OM 377.973	D	187
1618	07.1998 →	OM 904.912	D	240	1723		OM 377.960	D	187
1621	09.1969 → 12.1972	OM 355.966	D	359	1723		OM 377.961	D	236
1621	09.1969 →	M 376.922	G	182	1725		OM 475.951	D	401
1621	09.1969 →	OM 366.941	D	190	1725		OM 906.975	D	261
1621	09.1969 →	OM 366.942	D	190	1725		OM 906.988	D	241
1621	09.1969 →	OM 366.943	D	190	1729	01.1980 → 05.1989	OM 422.916	D	370



			Pos				Pos
1729	01.1980 → 08.1994	OM 442.905	D	504	1921	09.1969 →	OM 335.930 D 368
1729	01.1980 → 08.1994	OM 442.909	D	504	1921	09.1969 →	OM 357.926 D 192
1729	01.1980 → 08.1994	OM 442.910	D	504	1923	01.1964 →	OM 346.917 D 361
1729	01.1980 → 08.1994	OM 442.911	D	504	1923	1967 → 1978	OM 355.914 D 365
1729	01.1980 → 08.1994	OM 442.914	D	504	1923	09.1969 → 12.1974	OM 355.913 D 365
1729	01.1980 → 08.1994	OM 442.915	D	504	1924	09.1967 → 08.1969	OM 355.960 D 359
1729	01.1980 → 08.1994	OM 442.916	D	504	1924	09.1967 →	OM 355.968 D 366
1729	01.1980 → 08.1994	OM 442.917	D	504	1924	09.1967 →	OM 355.977 D 366
1729	01.1980 → 08.1994	OM 442.918	D	504	1924	09.1967 →	OM 357.949 D 190
1729	01.1980 → 08.1994	OM 442.919	D	504	1924	09.1967 →	OM 407.930 D 322
1729	01.1980 → 08.1994	OM 442.920	D	504	1924	09.1967 →	OM 496.900-001 D 323
1729	01.1980 → 08.1994	OM 442.921	D	504		(AFS)	
1729	01.1980 → 08.1994	OM 442.924	D	504	1924	09.1967 →	OM 496.900-026 D 323
1729	01.1980 → 08.1994	OM 442.927	D	504		(AFS)	
1729	01.1980 → 08.1994	OM 442.928	D	504	1924	09.1967 →	OM 496.900-027 D 323
1729	01.1980 → 08.1994	OM 442.929	D	504		(AFS)	
1729	01.1980 → 08.1994	OM 442.930	D	504	1924	09.1969 → 05.1977	OM 355.963 D 359
1729	01.1980 → 08.1994	OM 442.932	D	504	1924	04.1972 → 1985	OM 402.917 D 327
1729	01.1980 → 08.1994	OM 442.933	D	504	1924	10.1975 →	OM 345.913 D 377
1729	01.1980 → 08.1994	OM 442.934	D	504	1924	10.1975 →	OM 355.964 D 359
1729	01.1980 → 08.1994	OM 442.935	D	504	1924	05.1979 → 06.1984	OM 355.984 D 367
1729	01.1980 → 08.1994	OM 442.939	D	504	1924	05.1979 → 02.2001	OM 355.983 D 367
1729	01.1980 → 08.1994	OM 443.905	D	503	1924	04.1983 →	OM 345.910 D 376
1729	03.1987 → 05.1989	OM 442.908	D	504	1924	04.1983 →	OM 345.912 D 376
1729	07.1988 → 09.1993	OM 442.926	D	504	1925	01.1979 → 1988	OM 422.909 D 370
1729	07.1988 → 08.1994	OM 442.906	D	504	1927	01.1991 →	OM 401.973 D 336
1729	07.1988 → 08.1994	OM 442.907	D	504	1930	10.1975 →	OM 345.913 D 377
1729	07.1988 → 08.1994	OM 442.922	D	504	1934		OM 345.953 (BRA) D 368
1729	07.1988 → 08.1994	OM 442.923	D	504	1941		OM 476.982 D 401
1729	07.1988 → 08.1994	OM 442.925	D	504	<b>20T-SERIES</b>		
1730		OM 926.926	D	282	2013		OM 344.963 D 134
1730		OM 926.932	D	291	2013		OM 352.900-016 D 135
1730		OM 926.942	D	291	2013		OM 352.904 D 129
1732	01.1989 → 07.1992	OM 441.960	D	404	2013		OM 352.908 D 130
1750	01.1985 → 02.1991	OM 442.989	D	391	2013		OM 352.915 D 129
1750	07.1995 →	OM 440.971	D	413	2013		OM 352.917 D 129
<b>18T-SERIES</b>					2013		OM 352.944 D 129
1813	01.1968 → 12.1973	OM 352.963	D	130	2013		OM 352.948 D 129
1813	01.1972 → 07.1983	OM 353.911	D	141	2013		OM 352.953 D 129
1813	09.1973 → 07.1983	OM 352.994	D	133	2013		OM 352.954 D 129
1816	09.1989 → 08.1994	OM 366.952	D	195	2013		OM 352.955 D 129
1817	01.1968 → 12.1976	OM 360.943	D	321	2013		OM 352.987 D 129
1817	01.1972 → 12.1976	OM 360.963	D	321	2013		OM 352.991 D 129
1817	05.1988 →	OM 382.913	D	218	2013		OM 352.992 D 129
1819	01.1972 → 12.1976	OM 360.963	D	321	2014		OM 344.963 D 134
1819	01.1972 → 05.1987	OM 345.915	D	363	2014		OM 352.900-016 D 135
1819	11.1974 → 05.1987	OM 401.905	D	325	2014		OM 352.904 D 129
1821	07.1985 →	OM 382.919	D	218	2014		OM 352.908 D 130
1821	07.1985 →	OM 382.971	D	218	2014		OM 352.915 D 129
1829	01.1994 →	OM 445.934	D	372	2014		OM 352.917 D 129
1829	01.1995 →	OM 445.935	D	372	2014		OM 352.944 D 129
1835	01.1996 →	OM 446.946	D	436	2014		OM 352.948 D 129
1835	01.1996 →	OM 466.900-405	D	374	2014		OM 352.953 D 129
1835	01.1996 →	OM 466.900-505	D	388	2014		OM 352.954 D 129
1836		OM 457.944	D	454	2014		OM 352.955 D 129
1842		OM 457.944	D	454	2014		OM 352.987 D 129
1842		OM 460.960	D	487	2014		OM 352.991 D 129
<b>19T-SERIES</b>					2014		OM 352.992 D 129
1916	02.1977 → 01.1987	OM 401.923	D	325	2017	09.1973 →	OM 344.938 D 144
1918	01.1966 → 12.1973	OM 346.914	D	361	2023	01.1964 → 1967	OM 346.912 D 361
1920	01.1964 → 1967	OM 346.910	D	361	2053	01.1996 →	OM 446.920 D 439
1920	01.1964 → 1967	OM 346.912	D	361	<b>21T-SERIES</b>		
1920	01.1964 → 1967	OM 346.913	D	361	2121		OM 390.900-505 D 189
1920	01.1964 → 1967	OM 346.917	D	361		(AMS)	
1920	01.1964 →	OM 376.967	D	186	2121		OM 390.900-506 D 189
1920	07.1985 →	OM 366.996	D	190	2121		OM 390.900-512 D 189
1920	02.1990 →	OM 356.985	D	190	2121		OM 390.900-517 D 189
1920	03.1992 →	OM 356.978	D	190	2121		OM 390.900-518 D 189
1921	09.1969 → 12.1972	OM 355.966	D	359	<b>22T-SERIES</b>		
					2213		OM 344.920 D 163

M

		Pos			Pos	
	OM 344.963	D 134	2318	OM 366.943	D 190	
	OM 352.900-016	D 135	2318	OM 376.946	D 186	
	OM 352.904	D 129	2318	OM 376.955	D 186	
	OM 352.915	D 129	2318	OM 376.958	D 186	
	OM 352.917	D 129	2325	OM 475.951	D 401	
	OM 352.944	D 129	2325	OM 475.954	D 401	
	OM 352.948	D 129	<b>24T-SERIES</b>			
	OM 352.953	D 129	2414	OM 376.907	D 185	
	OM 352.954	D 129	2414	OM 376.930	D 185	
	OM 352.955	D 129	2418	OM 376.946	D 186	
	OM 352.987	D 129	2418	OM 376.947	D 186	
	OM 352.991	D 129	2418	OM 376.955	D 186	
	OM 352.992	D 129	2418	OM 376.956	D 186	
	OM 344.920	D 163	2418	OM 376.958	D 186	
	OM 344.963	D 134	2421	OM 386.980	D 196	
	OM 352.900-016	D 135	2423	OM 377.960	D 187	
	OM 352.904	D 129	2423	OM 377.963	D 187	
	OM 352.915	D 129	2423	OM 476.982	D 401	
	OM 352.917	D 129	2423	OM 906.985	D 241	
	OM 352.944	D 129	2436	OM 423.907	D 382	
	OM 352.948	D 129	2436	OM 423.905	D 382	
	OM 352.953	D 129	2436	OM 442.950	D 390	
	OM 352.954	D 129	2436	OM 442.952	D 390	
	OM 352.955	D 129	2436	OM 442.962	D 391	
	OM 352.987	D 129	2445	OM 462.900-411	D 407	
	OM 352.991	D 129		(AFS)		
	OM 352.992	D 129	<b>25T-SERIES</b>			
	OM 344.953	D 144	2517	OM 382.913	D 218	
	OM 352.900-016	D 135	2521	OM 382.919	D 218	
	OM 352.904	D 129	2522	OM 441.923	D 503	
	OM 352.915	D 129	2527	OM 442.914	D 504	
	OM 352.916	D 133	2527	OM 442.932	D 504	
	OM 352.917	D 129	2527	OM 401.973	D 336	
	OM 352.944	D 129	2527	OM 401.978	D 336	
	OM 352.948	D 129	2527	OM 401.980	D 336	
	OM 352.953	D 129	2527	OM 401.977	D 336	
	OM 352.954	D 129	2527	OM 445.926	D 372	
	OM 352.955	D 129	2527	OM 445.927	D 372	
	OM 352.987	D 129	2527	OM 445.936	D 372	
	OM 352.991	D 129	2527	OM 445.940	D 372	
	OM 352.992	D 129	2529	OM 442.971	D 391	
	OM 366.941	D 190	2529	OM 443.940	D 404	
	OM 366.942	D 190	2529	OM 442.924	D 504	
	OM 366.943	D 190	2529	OM 442.929	D 504	
	OM 344.938	D 144	2529	OM 442.906	D 504	
	OM 344.953	D 144	2532	OM 445.929	D 372	
	OM 352.900-016	D 135	2535	OM 442.952	D 390	
	OM 352.904	D 129	2535	OM 442.962	D 391	
	OM 352.915	D 129	2539	OM 442.966	D 391	
	OM 352.916	D 133	2540	OM 402.971	D 338	
	OM 352.917	D 129	2545	OM 462.900-511	D 407	
	OM 352.944	D 129		(AFS)		
	OM 352.948	D 129	<b>26T-SERIES</b>			
	OM 352.953	D 129	2620	OM 346.910	D 361	
	OM 352.954	D 129	2620	OM 346.913	D 361	
	OM 352.955	D 129	2622	OM 421.905	D 382	
	OM 352.987	D 129	2622	OM 481.902	D 385	
	OM 352.991	D 129	2627	OM 401.978	D 336	
	OM 352.992	D 129	2627	OM 401.975	D 336	
	OM 344.938	D 144	2637	OM 482.941	D 434	
	OM 390.900-517	D 189	2645	OM 442.953	D 390	
	OM 355.962	D 359	2645	OM 443.940	D 404	
	OM 442.907	D 504	2645	OM 443.980	D 415	
	OM 457.944	D 454	<b>28T-SERIES</b>			
	<b>23T-SERIES</b>			2822	OM 421.905	D 382
	OM 376.907	D 185	2825	OM 421.905	D 382	
	OM 376.957	D 186	2828	OM 422.911	D 370	
	OM 366.941	D 190	2828	OM 422.905	D 370	
	OM 366.942	D 190	2828	OM 422.913	D 370	

M

				Pos					Pos
2828	05.1982 →	OM 421.905	D	382	4435	10.1989 → 02.2001	OM 442.944	D	390
2833	04.1984 →	OM 422.954	D	381	4435	10.1989 → 02.2001	OM 442.945	D	390
<b>30T-SERIES</b>					4435	10.1989 → 02.2001	OM 442.950	D	390
3031	03.1991 →	OM 401.979	D	336	4435	10.1989 → 02.2001	OM 442.952	D	390
3035	01.1985 → 02.1991	OM 442.952	D	390	4435	10.1989 → 02.2001	OM 442.966	D	391
<b>32T-SERIES</b>					4436	01.1981 → 02.2001	OM 423.907	D	382
3240	01.1985 → 02.1991	OM 442.989	D	391	4436	11.1981 → 03.1991	OM 423.906	D	382
<b>33T-SERIES</b>					4436	12.1982 → 11.1991	OM 423.905	D	382
3332	08.1973 → 09.1983	OM 403.931	D	330	4436	1985 → 02.2001	OM 442.962	D	391
3332	05.1974 → 09.1983	OM 403.932	D	330	4436	1989 → 02.2001	OM 443.940	D	404
3344	01.1985 → 02.1991	OM 442.951	D	390	4436	10.1989 → 02.2001	OM 442.950	D	390
3344	01.1985 → 02.1991	OM 442.953	D	390	4436	10.1989 → 02.2001	OM 442.952	D	390
<b>36T-SERIES</b>					4436	10.1989 → 02.2001	OM 443.980	D	415
3636	01.1981 →	OM 423.907	D	382	4445	10.1989 → 02.1991	OM 442.962	D	391
3636	11.1981 → 03.1991	OM 423.906	D	382	<b>46T-SERIES</b>				
3636	12.1982 → 11.1991	OM 423.905	D	382	4635	10.1989 → 02.2001	OM 442.952	D	390
3636	1985 → 02.1991	OM 442.952	D	390	4644	07.1995 → 05.1998	OM 440.970	D	412
<b>38T-SERIES</b>					4645	01.1985 → 02.1991	OM 442.953	D	390
3833	12.1982 → 11.1991	OM 422.954	D	381	4645	10.1989 → 02.1991	OM 443.940	D	404
3833	12.1982 → 11.1991	OM 422.957	D	381	4645	10.1989 → 02.2001	OM 442.942	D	390
3835	10.1989 → 02.1991	OM 442.952	D	390	4645	10.1989 → 02.2001	OM 442.950	D	390
<b>3T-SERIES</b>					4645	10.1989 → 02.2001	OM 442.952	D	390
311	01.1964 → 12.1982	OM 352.992	D	129	4645	10.1989 → 02.2001	OM 442.959	D	390
311	1974 → 1982	OM 352.979	D	129	4645	10.1989 → 02.2001	OM 442.962	D	391
311	1974 → 1982	OM 352.981	D	130	4645	10.1989 → 02.2001	OM 442.966	D	391
311	1974 → 1982	OM 352.983	D	129	4648	10.1989 → 02.1991	OM 443.940	D	404
312	01.1964 → 12.1982	OM 352.904	D	129	4648	10.1989 → 02.2001	OM 442.942	D	390
312	01.1964 → 12.1982	OM 352.953	D	129	4648	10.1989 → 02.2001	OM 442.959	D	390
312	01.1964 → 12.1982	OM 352.955	D	129	4648	10.1989 → 02.2001	OM 442.966	D	391
312	01.1964 → 12.1982	OM 352.987	D	129	<b>48T-SERIES</b>				
312	01.1964 → 12.1982	OM 352.991	D	129	4836	01.1981 →	OM 423.907	D	382
312	01.1964 → 12.1982	OM 352.992	D	129	4836	11.1981 → 03.1991	OM 423.906	D	382
312	1974 → 1982	OM 352.979	D	129	4836	12.1982 → 11.1991	OM 423.905	D	382
312	1974 → 1982	OM 352.981	D	130	4836	1985 → 02.1991	OM 442.962	D	391
312	1974 → 1982	OM 352.983	D	129	4838	01.1996 →	OM 446.939	D	439
321	01.1974 → 1982	OM 352.982	D	130	4853	01.1996 →	OM 446.920	D	439
322	01.1964 → 1970	OM 352.912	D	129	4853	01.1996 →	OM 446.940	D	436
322	01.1964 → 1981	OM 352.953	D	129	<b>49T-SERIES</b>				
322	01.1964 → 1981	OM 352.954	D	129	4936	01.1985 → 02.1991	OM 442.952	D	390
322	01.1964 → 1981	OM 352.955	D	129	<b>50T-SERIES</b>				
322	01.1964 → 12.1982	OM 352.904	D	129	5035	01.1985 → 02.1991	OM 442.942	D	390
322	01.1964 → 12.1982	OM 352.987	D	129	5035	01.1985 → 02.1991	OM 442.966	D	391
322	01.1964 → 12.1982	OM 352.991	D	129	5038	07.1995 →	OM 440.988	D	424
322	1971 → 1982	OM 352.913	D	133	<b>52T-SERIES</b>				
322	1971 → 1982	OM 352.949	D	133	5248	01.1985 → 02.1991	OM 442.984	D	391
322	09.1973 → 12.1982	OM 352.950	D	133	<b>54T-SERIES</b>				
322	1974 → 1982	OM 352.944	D	129	5436	01.1981 →	OM 423.907	D	382
326	01.1964 → 1967	OM 346.941	D	361	5436	12.1982 → 11.1991	OM 423.905	D	382
326	01.1964 → 1967	OM 346.942	D	361	5436	1985 → 02.1991	OM 442.950	D	390
329	01.1964 → 1967	OM 346.943	D	361	5436	1985 → 02.1992	OM 442.952	D	390
329	01.1964 → 1967	OM 346.944	D	361	5436	04.1987 → 02.1991	OM 443.940	D	404
329	01.1964 → 1967	OM 346.945	D	361	5436	1989 → 02.1991	OM 443.980	D	415
329	01.1964 → 1981	OM 352.948	D	129	<b>60T-SERIES</b>				
331	01.1964 → 1967	OM 346.943	D	361	6036	01.1981 →	OM 423.907	D	382
331	01.1964 → 1967	OM 346.944	D	361	6036	12.1982 → 11.1991	OM 423.905	D	382
331	01.1964 → 1967	OM 346.945	D	361	6036	1985 → 02.1991	OM 442.950	D	390
332	01.1964 → 1967	OM 346.943	D	361	6036	1985 → 02.1991	OM 442.952	D	390
332	01.1964 → 1967	OM 346.944	D	361	6036	10.1989 → 02.1991	OM 443.940	D	404
332	01.1964 → 1967	OM 346.945	D	361	6036	10.1989 → 02.1991	OM 443.980	D	415
333	01.1964 → 1967	OM 346.942	D	361	<b>6T-SERIES</b>				
334	01.1964 → 1967	OM 346.941	D	361	610	06.1985 →	OM 374.991	D	189
334	01.1964 → 1967	OM 346.942	D	361	610	06.1985 →	OM 374.993	D	189
<b>40T-SERIES</b>					610	06.1985 →	OM 374.996	D	189
4044	01.1985 → 02.1991	OM 442.951	D	390	610	06.1985 →	OM 374.953	D	207
4044	01.1985 → 02.1991	OM 442.953	D	390	610	06.1994 →	OM 354.902	D	212
<b>41T-SERIES</b>					<b>7T-SERIES</b>				
4150	07.1995 → 06.1995	OM 440.981	D	412	708		M 343.920	AL	128
<b>44T-SERIES</b>					708		OM 343.910	D	174
4435	01.1985 → 02.2001	OM 442.962	D	391	708		OM 343.932	D	174

M

			Pos				Pos		
708		OM 352.908	D	130	912	06.1985 →	OM 364.986	D	212
708		OM 352.916	D	133	912	06.1985 →	OM 364.987	D	212
710	07.1964 → 02.1970	OM 352.910	D	129	912	06.1985 →	OM 364.989	D	213
710	07.1964 →	OM 352.904	D	129	912	06.1985 →	OM 366.941	D	190
710	07.1964 →	OM 352.908	D	130	912	06.1985 →	OM 366.942	D	190
710	07.1964 →	OM 352.953	D	129	912	06.1985 →	OM 366.943	D	190
710	07.1964 →	OM 352.955	D	129	912	06.1985 →	OM 374.950	D	214
710	07.1964 →	OM 352.987	D	129	915		OM 904.957	D	240
710	07.1964 →	OM 352.991	D	129	<b>ACCELO</b>				
710	07.1964 →	OM 370.905	D	188	710	05.2003 →	OM 374.992	D	189
710	07.1964 →	OM 374.991	D	189	715 C	05.2003 →	OM 612.965	D	70
710	07.1964 →	OM 374.993	D	189	715 C	05.2003 →	OM 612.966	D	70
710	07.1964 →	OM 374.996	D	189	715 C	05.2003 →	OM 612.983	D	70
710	07.1964 →	OM 374.905	D	188	915, 915 C	05.2003 →	OM 904.943	D	240
710	07.1964 →	OM 374.976	D	189	915, 915 C	05.2003 →	OM 904.957	D	240
710	07.1964 →	OM 374.992	D	189	915, 915 C	05.2003 →	OM 904.965	D	264
710	1974 → 1982	OM 352.932	D	129	915, 915 C	05.2003 →	OM 904.966	D	240
710	1974 → 1982	OM 352.933	D	129	915, 915 C	05.2003 →	OM 904.970	D	240
710	1974 → 1982	OM 352.942	D	129	<b>ACTROS</b>				
710	1974 → 1982	OM 352.972	D	129	1831 AK	04.1997 → 10.2002	OM 541.926	D	514
710	1974 → 1982	OM 352.973	D	129	1831 AK	04.1997 → 10.2002	OM 541.941	D	514
710	06.1985 →	OM 370.952	D	215	1831 K	04.1997 → 10.2002	OM 541.920	D	523
710	06.1985 →	OM 374.953	D	207	1831 K	04.1997 → 10.2002	OM 541.940	D	514
710	06.1994 →	OM 354.902	D	212	1831 S, 1831 LS	09.1996 → 10.2002	OM 541.920	D	523
710	06.1994 →	OM 354.903	D	212	1831 S, 1831 LS	10.1998 → 10.2002	OM 541.940	D	514
710	04.1995 →	OM 374.986	D	215	1831, 1831 L	09.1996 → 10.2002	OM 541.920	D	523
710	04.1995 →	OM 374.988	D	215	1835 AK	04.1997 → 10.2002	OM 541.927	D	514
712	06.1985 →	OM 364.985	D	213	1835 AK	10.1997 → 10.2002	OM 541.943	D	514
712	06.1985 →	OM 364.986	D	212	1835 K	04.1997 → 10.2002	OM 541.922	D	514
712	06.1985 →	OM 364.987	D	212	1835 K	04.1997 → 10.2002	OM 541.942	D	514
712	06.1985 →	OM 364.989	D	213	1835 S, 1835 LS	09.1996 → 10.2002	OM 541.922	D	514
712	06.1985 →	OM 374.991	D	189	1835 S, 1835 LS	10.1998 → 10.2002	OM 541.942	D	514
712	06.1985 →	OM 374.993	D	189	1835, 1835 L	09.1996 → 10.2002	OM 541.922	D	514
712	06.1985 →	OM 374.994	D	189	1840 AK	04.1997 → 10.2002	OM 541.924	D	514
712	06.1985 →	OM 374.996	D	189	1840 AK	10.1997 → 10.2002	OM 541.945	D	514
712	06.1985 →	OM 374.951	D	214	1840 K	04.1997 → 10.2002	OM 541.923	D	514
712	06.1985 →	OM 374.977	D	189	1840 K	04.1997 → 10.2002	OM 541.944	D	514
712	06.1985 →	OM 374.979	D	189	1840 S, 1840 LS	09.1996 → 10.2002	OM 541.923	D	514
712	06.1985 →	OM 904.918	D	240	1840 S, 1840 LS	10.1998 → 10.2002	OM 541.944	D	514
712	06.1985 →	OM 906.985	D	241	1840, 1840 L	09.1996 → 10.2002	OM 541.923	D	514
<b>8T-SERIES</b>					1843 AK	04.1997 → 10.2002	OM 541.921	D	523
810	01.1964 → 1981	OM 352.934	D	129	1843 AK	04.1997 → 10.2002	OM 541.921	D	523
810	01.1964 →	OM 352.904	D	129	1843 AK	04.1997 → 10.2002	OM 541.947	D	514
810	01.1964 →	OM 352.908	D	130	1843 AK	04.1997 → 10.2002	OM 541.947	D	514
810	01.1964 →	OM 352.953	D	129	1843 K	04.1997 → 10.2002	OM 541.925	D	514
810	01.1964 →	OM 352.955	D	129	1843 K	04.1997 → 10.2002	OM 541.946	D	514
810	01.1964 →	OM 352.987	D	129	1843 S, 1843 LS	09.1996 → 10.2002	OM 541.925	D	514
810	01.1964 →	OM 352.991	D	129	1843 S, 1843 LS	10.1998 → 10.2002	OM 541.946	D	514
810	01.1964 →	OM 352.996	D	129	1843, 1843 L	09.1996 → 10.2002	OM 541.925	D	514
810	01.1967 → 03.1977	OM 352.907	D	129	1846	09.2001 → 12.2003	OM 541.948	D	512
810	01.1967 → 03.1977	OM 352.986	D	129	1846 AK	04.1997 → 10.2003	OM 541.948	D	512
810	01.1972 → 03.1977	OM 353.909	D	133	1846 AK	10.1997 → 10.2003	OM 541.949	D	512
810	1974 → 1982	OM 352.909	D	129	1846 S, 1846 LS	10.1998 → 10.2002	OM 541.948	D	512
810	1974 → 1982	OM 352.985	D	129	1848 AK	04.1997 → 10.2002	OM 542.925	D	525
810	06.1994 →	OM 354.903	D	212	1848 K	04.1997 → 10.2002	OM 542.921	D	524
812	06.1985 →	OM 364.985	D	213	1848 K	04.1997 → 10.2002	OM 542.940	D	519
812	06.1985 →	OM 364.986	D	212	1848 S, 1848 LS	04.1996 → 10.2002	OM 542.940	D	519
812	06.1985 →	OM 364.987	D	212	1848 S, 1848 LS	09.1996 → 10.2002	OM 542.921	D	524
812	06.1985 →	OM 364.989	D	213	1848, 1848 L	09.1996 → 10.2002	OM 542.921	D	524
812	06.1985 →	OM 374.991	D	189	1850 AK	10.1997 → 10.2003	OM 542.941	D	519
812	06.1985 →	OM 374.993	D	189	1853 S, 1853 LS	09.1996 → 10.2002	OM 542.920	D	524
812	06.1985 →	OM 374.996	D	189	1853 S, 1853 LS	10.1996 → 10.2002	OM 542.942	D	519
812	06.1985 →	OM 374.950	D	214	1853, 1853 L	09.1996 → 10.2002	OM 542.920	D	524
812	06.1985 →	OM 374.952	D	214	1857 L	04.1997 → 10.2002	OM 542.922	D	526
812	06.1985 →	OM 374.977	D	189	1857 LS	04.1997 → 10.2002	OM 542.922	D	526
812	06.1985 →	OM 374.978	D	189	1857 LS	10.1997 → 10.2002	OM 542.944	D	519
812	06.1985 →	OM 374.979	D	189	2031	04.1997 → 10.2002	OM 541.920	D	523
<b>9T-SERIES</b>					2031 A	04.1997 → 10.2002	OM 541.926	D	514
912	06.1985 →	OM 364.985	D	213	2031 AK	09.1996 → 10.2002	OM 541.926	D	514



			Pos				Pos		
2031 AK	10.1997 → 10.2002	OM 541.941	D	514	2643 S, 2643 LS	04.1997 → 10.2002	OM 541.925	D	514
2031 AS	09.1996 → 10.2002	OM 541.926	D	514	2643 S, 2643 LS	04.1997 → 10.2002	OM 541.946	D	514
2031 AS	10.1996 → 10.2002	OM 541.941	D	514	2643, 2643 L	04.1997 → 10.2002	OM 541.925	D	514
2031 K	04.1997 → 10.2002	OM 541.920	D	523	2646 S, 2646 LS	10.1997 → 10.2002	OM 541.948	D	512
2031 K	04.1997 → 10.2002	OM 541.940	D	514	2648 K, 2648 LK	04.1997 → 10.2002	OM 542.921	D	524
2031 S	09.1996 → 10.2002	OM 541.920	D	523	2648 K, 2648 LK	04.1997 → 10.2002	OM 542.940	D	519
2031 S	10.1996 → 10.2002	OM 541.940	D	514	2648 K, 2648 LK	10.1997 → 10.2002	OM 541.948	D	512
2035 A	04.1997 → 10.2002	OM 541.927	D	514	2648 S, 2648 LS	09.1996 → 10.2002	OM 542.921	D	524
2035 A	04.1997 → 10.2002	OM 541.943	D	514	2648 S, 2648 LS	09.1996 → 10.2002	OM 542.940	D	519
2035 S	09.1996 → 10.2002	OM 541.922	D	514	2648 S, 2648 LS	10.1997 → 10.2002	OM 541.948	D	512
2035 S	10.1996 → 10.2002	OM 541.942	D	514	2648, 2648 L	09.1996 → 10.2002	OM 542.921	D	524
2036	09.1996 → 02.2003	OM 541.943	D	514	2650 S, 2650 LS	10.1997 → 10.2002	OM 542.940	D	519
2040	09.1996 → 10.2002	OM 541.923	D	514	2653 K, 2653 LK	04.1997 → 10.2002	OM 542.920	D	524
2040 AK	09.1996 → 10.2002	OM 541.924	D	514	2653 K, 2653 LK	10.1997 → 10.2002	OM 542.942	D	519
2040 AK	10.1997 → 10.2002	OM 541.945	D	514	2653 S, 2653 LS	09.1996 → 10.2002	OM 542.920	D	524
2040 AS	09.1996 → 10.2002	OM 541.924	D	514	2653 S, 2653 LS	10.1997 → 10.2002	OM 542.942	D	519
2040 AS	10.1996 → 10.2002	OM 541.945	D	514	2653, 2653 L	04.1997 → 10.2002	OM 542.920	D	524
2040 S	09.1996 → 10.2002	OM 541.923	D	514	2657 K, 2657 LK	04.1997 → 10.2002	OM 542.922	D	526
2040 S	10.1996 → 10.2002	OM 541.944	D	514	2657 K, 2657 LK	10.1997 → 10.2002	OM 542.944	D	519
2043 AS	04.1996 → 10.2002	OM 541.925	D	514	2657 L	04.1997 → 10.2002	OM 542.922	D	526
2043 AS	10.1997 → 02.2001	OM 541.947	D	514	2657 S, 2657 LS	04.1997 → 10.2002	OM 542.922	D	526
2043 AS	10.1997 → 10.2002	OM 541.921	D	523	2657 S, 2657 LS	10.1997 → 10.2002	OM 542.944	D	519
2046	09.2001 → 12.2003	OM 541.948	D	512	2665 LS	10.2002 → 11.2002	OM 542.968	D	529
2046 AS	10.1996 → 10.2002	OM 541.949	D	512	2665 LS	10.2002 → 11.2002	OM 542.969	D	529
2048 AS	09.1996 → 10.2002	OM 542.925	D	525	3231 K	04.1997 → 10.2002	OM 541.920	D	523
2050 AS	10.1996 → 10.2003	OM 542.941	D	519	3231 K	10.1997 → 10.2002	OM 541.940	D	514
2053 S	09.1996 → 10.2002	OM 542.920	D	524	3235	04.1997 → 10.2002	OM 541.922	D	514
2053 S	10.1996 → 02.2002	OM 542.942	D	519	3235	04.1997 → 10.2002	OM 541.942	D	514
2531 LS	09.1996 → 10.2002	OM 541.920	D	523	3235 K	04.1997 → 10.2002	OM 541.922	D	514
2531 LS	10.1997 → 10.2002	OM 541.940	D	514	3235 K	10.1997 → 10.2002	OM 541.942	D	514
2531, 2531 L	09.1996 → 10.2002	OM 541.920	D	523	3240	04.1997 → 10.2002	OM 541.923	D	514
2531, 2531 L	09.1996 → 10.2002	OM 541.920	D	523	3240	04.1997 → 10.2002	OM 541.944	D	514
2531, 2531 L	09.1996 → 10.2002	OM 541.940	D	514	3240 K	04.1997 → 10.2002	OM 541.923	D	514
2531, 2531 L	09.1996 → 10.2002	OM 541.940	D	514	3240 K	10.1999 → 10.2002	OM 541.944	D	514
2535 L	09.1996 → 10.2002	OM 541.922	D	514	3243	04.1997 → 10.2002	OM 541.925	D	514
2535 L	09.1996 → 10.2002	OM 541.922	D	514	3243	04.1997 → 10.2002	OM 541.946	D	514
2535 L	09.1996 → 10.2002	OM 541.942	D	514	3243 K	04.1997 → 10.2002	OM 541.925	D	514
2535 L	09.1996 → 10.2002	OM 541.942	D	514	3243 K	10.1997 → 10.2002	OM 541.946	D	514
2535 LS	09.1996 → 10.2002	OM 541.922	D	514	3246	09.2001 → 12.2003	OM 541.948	D	512
2535 LS	09.1996 → 10.2002	OM 541.942	D	514	3246 K	10.1997 → 10.2002	OM 541.948	D	512
2540 LS	09.1996 → 10.2002	OM 541.923	D	514	3331	04.1997 → 10.2002	OM 541.920	D	523
2540 LS	09.1996 → 10.2002	OM 541.944	D	514	3331 A	04.1997 → 10.2002	OM 541.926	D	514
2540, 2540 L	09.1996 → 10.2002	OM 541.923	D	514	3331 AK	04.1997 → 10.2002	OM 541.926	D	514
2540, 2540 L	09.1996 → 10.2002	OM 541.944	D	514	3331 AK	10.1997 → 10.2002	OM 541.941	D	514
2543 LS	09.1996 → 10.2002	OM 541.925	D	514	3331 AS	04.1997 → 10.2002	OM 541.926	D	514
2543 LS	09.1996 → 10.2002	OM 541.946	D	514	3331 AS	10.1997 → 10.2002	OM 541.941	D	514
2543, 2543 L	09.1996 → 10.2002	OM 541.925	D	514	3331 K	04.1997 → 10.2002	OM 541.920	D	523
2543, 2543 L	04.1997 → 10.2002	OM 541.946	D	514	3331 K	10.1997 → 10.2002	OM 541.940	D	514
2546 LS	10.1997 → 10.2002	OM 541.948	D	512	3331 S	04.1997 → 10.2002	OM 541.920	D	523
2548 LS	09.1996 → 10.2002	OM 542.921	D	524	3331 S	10.1997 → 10.2002	OM 541.940	D	514
2548 LS	09.1996 → 10.2002	OM 542.940	D	519	3335	04.1997 → 10.2002	OM 541.922	D	514
2548, 2548 L	09.1996 → 10.2002	OM 542.921	D	524	3335 AK	10.1997 → 10.2003	OM 541.927	D	514
2553 LS	09.1996 → 10.2002	OM 542.920	D	524	3335 AK	10.1997 → 10.2003	OM 541.943	D	514
2553 LS	10.1999 → 10.2002	OM 542.942	D	519	3335 K	04.1997 → 10.2002	OM 541.922	D	514
2553, 2553 L	09.1996 → 10.2002	OM 542.920	D	524	3335 K	10.1997 → 10.2002	OM 541.942	D	514
2557 L	04.1997 → 10.2002	OM 542.922	D	526	3335 S	04.1997 → 10.2002	OM 541.922	D	514
2631 K	04.1997 → 10.2002	OM 541.920	D	523	3336 S	10.1997 → 10.2002	OM 541.942	D	514
2631 K	10.1997 → 10.2002	OM 541.940	D	514	3340	04.1997 → 10.2002	OM 541.923	D	514
2631, 2631 L	04.1997 → 10.2002	OM 541.920	D	523	3340 A	04.1997 → 10.2002	OM 541.924	D	514
2635 K, 2635 LK	04.1997 → 10.2002	OM 541.922	D	514	3340 AK	04.1997 → 10.2002	OM 541.924	D	514
2635 K, 2635 LK	10.1997 → 10.2002	OM 541.942	D	514	3340 AK	10.1997 → 10.2002	OM 541.945	D	514
2635, 2635 L	04.1997 → 10.2002	OM 541.922	D	514	3340 AS	04.1997 → 10.2002	OM 541.924	D	514
2640 K, 2640 LK	04.1997 → 10.2002	OM 541.923	D	514	3340 AS	10.1997 → 10.2002	OM 541.945	D	514
2640 K, 2640 LK	10.1997 → 10.2002	OM 541.944	D	514	3340 K	04.1997 → 10.2002	OM 541.923	D	514
2640 S, 2640 LS	09.1996 → 10.2002	OM 541.923	D	514	3340 K	10.1997 → 10.2002	OM 541.944	D	514
2640 S, 2640 LS	10.1997 → 10.2002	OM 541.944	D	514	3340 S	04.1997 → 10.2002	OM 541.923	D	514
2640, 2640 L	04.1997 → 10.2002	OM 541.923	D	514	3341 S	10.1997 → 10.2002	OM 541.944	D	514
2643 K, 2643 LK	04.1997 → 10.2002	OM 541.925	D	514	3343	04.1997 → 10.2002	OM 541.925	D	514
2643 K, 2643 LK	10.1997 → 10.2002	OM 541.946	D	514	3343 AK	04.1997 → 10.2002	OM 541.921	D	523

M



			Pos				Pos
3343 AK	10.1997 → 10.2002	OM 541.947	D 514	3236	04.2003 → 12.2008	OM 541.942	D 514
3343 AS	04.1997 → 10.2002	OM 541.921	D 523	3244	06.2003 → 12.2008	OM 541.946	D 514
3343 AS	10.1997 → 10.2002	OM 541.947	D 514	3244 Blue Tec	02.2005 → 12.2008	OM 541.976	D 532
3343 K	04.1997 → 10.2002	OM 541.925	D 514	3336 Blue Tec	02.2005 → 12.2008	OM 541.972	D 532
3343 K	10.1997 → 10.2002	OM 541.946	D 514	3360 BlueTec	07.2005 → 12.2008	OM 542.964	D 539
3343 S	04.1997 → 10.2002	OM 541.925	D 514	4141	04.2003 → 12.2008	OM 541.944	D 514
3343 S	10.1997 → 10.2002	OM 541.946	D 514	4144 Blue Tec	02.2005 → 12.2008	OM 541.976	D 532
3346	09.2001 → 10.2002	OM 541.948	D 512	<b>ACTROS III</b>			
3346 AK	10.1997 → 10.2002	OM 541.949	D 512	1832 BlueTec	09.2008 →	OM 936.916	D 316
3346 AS	10.1997 → 10.2002	OM 541.949	D 512	1835 BlueTec	09.2008 →	OM 936.916	D 316
3346 K	10.1997 →	OM 541.948	D 512	2032 BlueTec	09.2008 →	OM 936.916	D 316
3346 S	10.1997 → 10.2002	OM 541.948	D 512	2035 BlueTec	09.2008 →	OM 936.916	D 316
3348	04.1997 → 10.2002	OM 542.921	D 524	2432 BlueTec	09.2008 →	OM 936.916	D 316
3348 AK	04.1997 → 10.2002	OM 542.925	D 525	2435 BlueTec	09.2008 →	OM 936.916	D 316
3348 AS	04.1997 → 10.2002	OM 542.925	D 525	2532 BlueTec	09.2008 →	OM 936.916	D 316
3348 K	04.1997 → 10.2002	OM 542.921	D 524	2535 BlueTec	09.2008 →	OM 936.916	D 316
3348 K	04.1997 → 10.2002	OM 542.940	D 519	2632 BlueTec	09.2008 →	OM 936.916	D 316
3348 S	04.1997 → 10.2002	OM 542.921	D 524	2635 BlueTec	09.2008 →	OM 936.916	D 316
3350 AK	10.1997 → 10.2003	OM 542.941	D 519	<b>ACTROS MP2 / MP3</b>			
3350 AS	10.1997 → 10.2002	OM 542.941	D 519	1831 AK	04.2003 →	OM 541.926	D 514
3350 K	10.1997 → 10.2002	OM 542.940	D 519	1831 AK	04.2003 →	OM 541.941	D 514
3350 S	10.1997 → 10.2002	OM 542.940	D 519	1831 K	04.2003 →	OM 541.920	D 523
3353	04.1997 → 10.2002	OM 542.920	D 524	1831 K	04.2003 →	OM 541.940	D 514
3353 AS	04.1997 → 10.2002	OM 542.920	D 524	1832 AK	04.2003 →	OM 541.940	D 514
3353 AS	10.1997 → 10.2002	OM 542.926	D 525	1832 AK	04.2003 →	OM 541.971	D 532
3353 AS	10.1997 → 10.2002	OM 542.943	D 519	1832 AK	04.2003 →	OM 541.997	D 530
3353 S	04.1997 → 10.2002	OM 542.920	D 524	1832 K	04.2003 →	OM 541.940	D 514
3353 S	10.1997 → 10.2002	OM 542.942	D 519	1832 K	04.2003 →	OM 541.970	D 531
3357	04.1997 → 10.2002	OM 542.922	D 526	1832 K	04.2003 →	OM 541.996	D 530
3357 S	04.1997 → 10.2002	OM 542.922	D 526	1832, L, LL	04.2003 → 12.2008	OM 541.940	D 514
3357 S	10.1997 → 10.2002	OM 542.944	D 519	1832, L, LL	02.2005 → 12.2008	OM 541.970	D 531
4040 k	11.2007 →	OM 541.944	D 514	1832, LS, LLS	04.2003 →	OM 541.940	D 514
4040 k	11.2007 →	OM 541.945	D 514	1832, LS, LLS	04.2003 →	OM 541.970	D 531
4140 AK	04.1997 → 10.2002	OM 541.924	D 514	1835 AK	04.2003 →	OM 541.927	D 514
4140 AK	10.1997 → 10.2002	OM 541.945	D 514	1835 AK	04.2003 →	OM 541.943	D 514
4140 K	04.1997 → 10.2002	OM 541.923	D 514	1835 K	04.2003 →	OM 541.922	D 514
4140 K	04.1997 → 10.2002	OM 541.924	D 514	1835 K	04.2003 →	OM 541.942	D 514
4140 K	10.1997 → 10.2002	OM 541.944	D 514	1836 A	10.2002 →	OM 541.943	D 514
4140 K	10.1997 → 10.2002	OM 541.945	D 514	1836 AK	04.2003 →	OM 541.942	D 514
4143 AK	04.1997 → 10.2002	OM 541.921	D 523	1836 AK	07.2010 →	OM 541.999	D 530
4143 AK	10.1997 → 10.2002	OM 541.947	D 514	1836 K	04.2003 → 12.2008	OM 541.942	D 514
4143 K	04.1997 → 10.2002	OM 541.921	D 523	1836 K	04.2003 → 12.2008	OM 541.972	D 532
4143 K	04.1997 → 10.2002	OM 541.925	D 514	1836 K	04.2003 → 12.2008	OM 541.998	D 530
4143 K	10.1997 → 10.2002	OM 541.946	D 514	1836 LS, LLS	04.2003 →	OM 541.942	D 514
4143 K	10.1997 → 10.2002	OM 541.947	D 514	1836, L, LL	04.2003 → 12.2008	OM 541.942	D 514
4146 AK	10.1997 → 10.2002	OM 541.948	D 512	1840 AK	04.2003 →	OM 541.924	D 514
4146 AK	10.1997 → 10.2002	OM 541.949	D 512	1840 AK	04.2003 →	OM 541.945	D 514
4146 K	10.1997 → 10.2002	OM 541.948	D 512	1840 K	04.2003 →	OM 541.923	D 514
4148 AK	04.1997 → 10.2002	OM 542.925	D 525	1840 K	04.2003 →	OM 541.944	D 514
4148 K	04.1997 → 10.2002	OM 542.921	D 524	1841 AK	04.2003 →	OM 541.991	D 530
4148 K	04.1997 → 10.2002	OM 542.925	D 525	1841 K	04.2003 →	OM 541.944	D 514
4840 K	11.2007 →	OM 541.944	D 514	1841 K	04.2003 →	OM 541.974	D 532
4840 K	11.2007 →	OM 541.945	D 514	1841 K	04.2003 →	OM 541.990	D 536
<b>ACTROS II</b>				1841 LS, LLS	04.2003 →	OM 541.944	D 514
1841 BlueTec	02.2005 → 12.2008	OM 541.974	D 532	1841 LS, LLS	04.2003 →	OM 541.974	D 532
1844 BlueTec	02.2005 → 12.2008	OM 541.976	D 532	1841 LS, LLS	04.2003 →	OM 541.990	D 536
1848 BlueTec	02.2005 → 12.2008	OM 541.978	D 532	1841, L, LL	04.2003 → 12.2008	OM 541.944	D 514
2051 Blue Tec	02.2005 → 12.2008	OM 542.960	D 540	1841, L, LL	04.2003 → 12.2008	OM 541.974	D 532
2051 Blue Tec	02.2005 → 12.2008	OM 542.961	D 539	1841, L, LL	04.2003 → 12.2008	OM 541.990	D 536
2441 BlueTec	02.2005 → 12.2008	OM 541.974	D 532	1844 AK	04.2003 →	OM 541.921	D 523
2444 BlueTec	02.2005 → 12.2008	OM 541.976	D 532	1844 AK	04.2003 →	OM 541.946	D 514
2446 BlueTec	02.2005 → 12.2008	OM 541.980	D 534	1844 AK	04.2003 →	OM 541.947	D 514
2451 BlueTec	02.2005 → 12.2008	OM 542.960	D 540	1844 AK	04.2003 →	OM 541.993	D 537
2455 BlueTec	02.2005 → 12.2008	OM 542.962	D 539	1844 K	04.2003 →	OM 541.925	D 514
2536 BlueTec	02.2005 → 12.2008	OM 541.972	D 532	1844 K	04.2003 →	OM 541.946	D 514
2541 BlueTec	02.2005 → 12.2008	OM 541.974	D 532	1844 K	04.2003 →	OM 541.976	D 532
2544 BlueTec	02.2005 → 12.2008	OM 541.976	D 532	1844 K	04.2003 →	OM 541.992	D 537
2646 Blue Tec	02.2005 → 12.2008	OM 541.980	D 534	1844 LS, LLS	04.2003 →	OM 541.946	D 514
2648 BlueTec	02.2005 → 12.2008	OM 541.978	D 532	1844 LS, LLS	04.2003 →	OM 541.976	D 532

			Pos				Pos		
1844 LS, LLS	04.2003 →	OM 541.992	D	537	2036 A, AE	04.2003 →	OM 541.943	D	514
1844, L, LL	04.2003 → 12.2008	OM 541.946	D	514	2036 AK	04.2003 →	OM 541.927	D	514
1844, L, LL	04.2003 → 12.2008	OM 541.976	D	532	2036 AK	04.2003 →	OM 541.942	D	514
1844, L, LL	04.2003 → 12.2008	OM 541.992	D	537	2036 AK	04.2003 →	OM 541.943	D	514
1846 AK	04.2003 →	OM 541.948	D	512	2036 AK	04.2003 →	OM 541.999	D	530
1846 AK	04.2003 →	OM 541.949	D	512	2036 AS	04.2003 →	OM 541.927	D	514
1846 AK	04.2003 →	OM 541.981	D	535	2036 AS	04.2003 →	OM 541.943	D	514
1846 AK	04.2003 →	OM 541.995	D	538	2036 K	04.2003 →	OM 541.922	D	514
1846 K	04.2003 →	OM 541.948	D	512	2036 K	04.2003 →	OM 541.942	D	514
1846 K	04.2003 →	OM 541.980	D	534	2036 K	04.2003 →	OM 541.972	D	532
1846 K	04.2003 →	OM 541.994	D	537	2036 K	04.2003 →	OM 541.998	D	530
1846 LS, LLS	04.2003 →	OM 541.948	D	512	2036 S	04.2003 → 12.2008	OM 541.942	D	514
1846 LS, LLS	04.2003 →	OM 541.980	D	534	2036 S	04.2003 → 12.2008	OM 541.972	D	532
1846, L, LL	04.2003 → 12.2008	OM 541.948	D	512	2040	10.2002 →	OM 541.923	D	514
1846, L, LL	02.2005 → 12.2008	OM 541.980	D	534	2040	10.2002 →	OM 541.944	D	514
1848 AK	04.2003 →	OM 541.948	D	512	2041	04.2003 → 12.2008	OM 541.944	D	514
1848 AK	04.2003 →	OM 542.925	D	525	2041	04.2003 → 12.2008	OM 541.974	D	532
1848 K	04.2003 →	OM 541.948	D	512	2041	04.2003 → 12.2008	OM 541.990	D	536
1848 K	04.2003 →	OM 541.978	D	532	2041 AK	04.2003 →	OM 541.924	D	514
1848 K	04.2003 →	OM 542.921	D	524	2041 AK	04.2003 →	OM 541.944	D	514
1848 K	04.2003 →	OM 542.940	D	519	2041 AK	04.2003 →	OM 541.945	D	514
1848 S, LS	04.2003 →	OM 542.921	D	524	2041 AK	04.2003 →	OM 541.991	D	530
1848, L, LL	04.2003 → 12.2008	OM 541.948	D	512	2041 AS	04.2003 →	OM 541.924	D	514
1848, L, LL	04.2003 → 12.2008	OM 541.978	D	532	2041 AS	04.2003 →	OM 541.991	D	530
1848, L, LL	04.2003 →	OM 542.921	D	524	2041 K	04.2003 →	OM 541.923	D	514
1848, LS, LLS	04.2003 →	OM 541.948	D	512	2041 K	04.2003 →	OM 541.944	D	514
1848, LS, LLS	04.2003 →	OM 541.978	D	532	2041 K	04.2003 →	OM 541.974	D	532
1850 AK, 1851 AK	04.2003 →	OM 542.940	D	519	2041 K	04.2003 →	OM 541.990	D	536
1850 AK, 1851 AK	04.2003 →	OM 542.941	D	519	2041 S	04.2003 →	OM 541.923	D	514
1850 AK, 1851 AK	05.2005 →	OM 542.960	D	540	2041 S	04.2003 →	OM 541.944	D	514
1850 AK, 1851 AK	05.2005 →	OM 542.961	D	539	2041 S	04.2003 →	OM 541.974	D	532
1850, 1851 K	04.2003 →	OM 542.940	D	519	2041 S	04.2003 →	OM 541.990	D	536
1850, 1851 K	05.2005 →	OM 542.960	D	540	2044	04.2003 → 12.2008	OM 541.946	D	514
1850, 1851 LS, LLS	04.2003 →	OM 542.940	D	519	2044	04.2003 → 12.2008	OM 541.976	D	532
1850, 1851 LS, LLS	05.2005 →	OM 542.960	D	540	2044	04.2003 → 12.2008	OM 541.992	D	537
1850, 1851, L, LL	04.2003 → 12.2008	OM 542.940	D	519	2044 AK	04.2003 →	OM 541.921	D	523
1850, 1851, L, LL	05.2005 → 12.2008	OM 542.960	D	540	2044 AK	04.2003 →	OM 541.947	D	514
1854 LS	04.2003 →	OM 542.942	D	519	2044 AK	04.2003 →	OM 541.993	D	537
1854, L	04.2003 → 12.2008	OM 542.942	D	519	2044 AS	04.2003 →	OM 541.921	D	523
1854, L	04.2003 → 12.2008	OM 542.962	D	539	2044 AS	04.2003 →	OM 541.947	D	514
1855 LS, LLS	06.2008 → 12.2008	OM 542.962	D	539	2044 K	04.2003 →	OM 541.925	D	514
1855, L, LL	06.2008 →	OM 542.962	D	539	2044 K	04.2003 →	OM 541.946	D	514
1858 LS	10.2002 →	OM 542.944	D	519	2044 K	04.2003 →	OM 541.976	D	532
1858, L	04.2003 → 12.2008	OM 542.944	D	519	2044 K	04.2003 →	OM 541.992	D	537
1860 L, LL	06.2006 → 12.2008	OM 542.964	D	539	2044 S	04.2003 →	OM 541.925	D	514
1860 LS	06.2008 →	OM 542.964	D	539	2044 S	04.2003 →	OM 541.946	D	514
1861 LS	05.2005 → 12.2008	OM 542.958	D	510	2044 S	04.2003 →	OM 541.976	D	532
2032	04.2003 → 12.2008	OM 541.920	D	523	2044 S	04.2003 →	OM 541.992	D	537
2032	04.2003 → 12.2008	OM 541.940	D	514	2046	04.2003 → 12.2008	OM 541.948	D	512
2032 A, AE	04.2003 →	OM 541.926	D	514	2046	02.2005 → 12.2008	OM 541.980	D	534
2032 A, AE	04.2003 →	OM 541.940	D	514	2046 AK	04.2003 →	OM 541.948	D	512
2032 A, AE	04.2003 →	OM 541.941	D	514	2046 AK	04.2003 →	OM 541.949	D	512
2032 AK	04.2003 →	OM 541.920	D	523	2046 AK	04.2003 →	OM 541.995	D	538
2032 AK	04.2003 →	OM 541.926	D	514	2046 AS	04.2003 →	OM 541.948	D	512
2032 AK	04.2003 →	OM 541.940	D	514	2046 K	04.2003 →	OM 541.948	D	512
2032 AK	04.2003 →	OM 541.941	D	514	2046 K	04.2003 →	OM 541.980	D	534
2032 AK	04.2003 →	OM 541.997	D	530	2046 K	04.2003 →	OM 541.994	D	537
2032 AS	04.2003 →	OM 541.926	D	514	2046 S	04.2003 →	OM 541.948	D	512
2032 AS	04.2003 →	OM 541.941	D	514	2046 S	04.2003 →	OM 541.980	D	534
2032 K	04.2003 → 12.2008	OM 541.920	D	523	2048	06.2008 →	OM 541.978	D	532
2032 K	04.2003 → 12.2008	OM 541.940	D	514	2048 AK	04.2003 →	OM 541.948	D	512
2032 K	04.2003 → 12.2008	OM 541.970	D	531	2048 AS	04.2003 → 12.2008	OM 541.948	D	512
2032 K	04.2003 → 12.2008	OM 541.996	D	530	2048 AS	04.2003 →	OM 542.925	D	525
2032 S	04.2003 →	OM 541.920	D	523	2048 K	04.2003 → 12.2008	OM 541.978	D	532
2032 S	04.2003 →	OM 541.940	D	514	2048 S	06.2008 →	OM 541.948	D	512
2036	04.2003 → 12.2008	OM 541.922	D	514	2048 S	06.2008 →	OM 541.978	D	532
2036	04.2003 → 12.2008	OM 541.942	D	514	2050 S	04.2003 → 12.2008	OM 542.940	D	519
2036 A, AE	04.2003 →	OM 541.927	D	514	2050 S	04.2003 → 12.2008	OM 542.941	D	519
2036 A, AE	04.2003 →	OM 541.942	D	514	2051 AS	04.2003 →	OM 542.940	D	519

M

# MERCEDES-BENZ

			Pos				Pos		
2051 AS	05.2005 →	OM 542.960	D	<b>540</b>	2544 LS	04.2003 →	OM 541.976	D	<b>532</b>
2051 S	06.2008 →	OM 542.940	D	<b>519</b>	2544 LS	04.2003 →	OM 541.976	D	<b>532</b>
2051 S	06.2008 →	OM 542.960	D	<b>540</b>	2544 LS	04.2003 →	OM 541.992	D	<b>537</b>
2054 S	04.2003 → 12.2008	OM 542.942	D	<b>519</b>	2544 LS	06.2008 →	OM 541.976	D	<b>532</b>
2055 S	06.2008 → 12.2008	OM 542.962	D	<b>539</b>	2544, L, LL	04.2003 → 12.2008	OM 541.925	D	<b>514</b>
2432 LS	06.2008 → 12.2008	OM 541.970	D	<b>531</b>	2544, L, LL	04.2003 → 12.2008	OM 541.946	D	<b>514</b>
2432 LS	06.2008 → 12.2008	OM 541.996	D	<b>530</b>	2544, L, LL	04.2003 → 12.2008	OM 541.976	D	<b>532</b>
2436 LS	06.2008 → 12.2008	OM 541.972	D	<b>532</b>	2544, L, LL	04.2003 → 12.2008	OM 541.992	D	<b>537</b>
2436 LS	06.2008 → 12.2008	OM 541.998	D	<b>530</b>	2544, L, LL	04.2003 →	OM 541.925	D	<b>514</b>
2441 LS	06.2008 →	OM 541.974	D	<b>532</b>	2544, L, LL	04.2003 →	OM 541.946	D	<b>514</b>
2441 LS	06.2008 →	OM 541.990	D	<b>536</b>	2544, L, LL	04.2003 →	OM 541.976	D	<b>532</b>
2444 LS	06.2008 →	OM 541.976	D	<b>532</b>	2544, L, LL	04.2003 →	OM 541.992	D	<b>537</b>
2444 LS	06.2008 →	OM 541.992	D	<b>537</b>	2546 LS	04.2003 → 12.2008	OM 541.948	D	<b>512</b>
2446 LS	06.2008 →	OM 541.980	D	<b>534</b>	2546 LS	04.2003 → 12.2008	OM 541.994	D	<b>537</b>
2446 LS	06.2008 →	OM 541.994	D	<b>537</b>	2546 LS	04.2003 →	OM 541.948	D	<b>512</b>
2448 LS	06.2008 → 12.2008	OM 541.978	D	<b>532</b>	2546 LS	04.2003 →	OM 541.980	D	<b>534</b>
2451 LS	06.2008 →	OM 542.960	D	<b>540</b>	2546 LS	02.2005 → 12.2008	OM 541.980	D	<b>534</b>
2455 LS	06.2008 →	OM 542.962	D	<b>539</b>	2546, L, LL	04.2003 →	OM 541.948	D	<b>512</b>
2460 LS	06.2008 →	OM 542.964	D	<b>539</b>	2546, L, LL	04.2003 →	OM 541.948	D	<b>512</b>
2532 LS	04.2003 →	OM 541.920	D	<b>523</b>	2546, L, LL	04.2003 →	OM 541.980	D	<b>534</b>
2532 LS	04.2003 →	OM 541.920	D	<b>523</b>	2546, L, LL	04.2003 →	OM 541.980	D	<b>534</b>
2532 LS	04.2003 →	OM 541.940	D	<b>514</b>	2546, L, LL	04.2003 →	OM 541.994	D	<b>537</b>
2532 LS	04.2003 →	OM 541.940	D	<b>514</b>	2546, L, LL	04.2003 →	OM 541.994	D	<b>537</b>
2532 LS	04.2003 →	OM 541.970	D	<b>531</b>	2548 L	04.2003 →	OM 542.921	D	<b>524</b>
2532 LS	04.2003 →	OM 541.970	D	<b>531</b>	2548 L	04.2003 →	OM 542.940	D	<b>519</b>
2532, L, LL	04.2003 → 12.2008	OM 541.920	D	<b>523</b>	2548 LS	04.2003 → 12.2008	OM 541.948	D	<b>512</b>
2532, L, LL	04.2003 → 12.2008	OM 541.940	D	<b>514</b>	2548 LS	04.2003 →	OM 541.948	D	<b>512</b>
2532, L, LL	04.2003 → 12.2008	OM 541.970	D	<b>531</b>	2548 LS	04.2003 →	OM 541.978	D	<b>532</b>
2532, L, LL	04.2003 → 12.2008	OM 541.996	D	<b>530</b>	2548 LS	02.2005 → 12.2008	OM 541.978	D	<b>532</b>
2532, L, LL	04.2003 →	OM 541.920	D	<b>523</b>	2548, L,LL	04.2003 → 12.2008	OM 541.948	D	<b>512</b>
2532, L, LL	04.2003 →	OM 541.940	D	<b>514</b>	2548, L,LL	04.2003 → 12.2008	OM 541.978	D	<b>532</b>
2532, L, LL	04.2003 →	OM 541.970	D	<b>531</b>	2548, L,LL	04.2003 →	OM 541.948	D	<b>512</b>
2532, L, LL	04.2003 →	OM 541.996	D	<b>530</b>	2548, L,LL	04.2003 →	OM 541.978	D	<b>532</b>
2536 LS	04.2003 →	OM 541.922	D	<b>514</b>	2550 LS	04.2003 →	OM 542.940	D	<b>519</b>
2536 LS	04.2003 →	OM 541.922	D	<b>514</b>	2550 LS	04.2003 →	OM 542.940	D	<b>519</b>
2536 LS	04.2003 →	OM 541.942	D	<b>514</b>	2550 LS	04.2003 → 12.2008	OM 542.940	D	<b>519</b>
2536 LS	04.2003 →	OM 541.942	D	<b>514</b>	2551 LS	05.2005 → 12.2008	OM 542.960	D	<b>540</b>
2536 LS	04.2003 →	OM 541.943	D	<b>514</b>	2551, L, LL	05.2005 →	OM 542.960	D	<b>540</b>
2536 LS	04.2003 →	OM 541.943	D	<b>514</b>	2551, L, LL	05.2005 →	OM 542.960	D	<b>540</b>
2536 LS	04.2003 →	OM 541.943	D	<b>514</b>	2553 L	04.2003 →	OM 542.920	D	<b>524</b>
2536 LS	04.2003 →	OM 541.972	D	<b>532</b>	2553 L	04.2003 →	OM 542.942	D	<b>519</b>
2536 LS	04.2003 →	OM 541.972	D	<b>532</b>	2554 LS	04.2003 →	OM 542.942	D	<b>519</b>
2536, L, LL	04.2003 → 12.2008	OM 541.922	D	<b>514</b>	2554, L	04.2003 → 12.2008	OM 542.942	D	<b>519</b>
2536, L, LL	04.2003 → 12.2008	OM 541.942	D	<b>514</b>	2555 LS	09.2005 → 12.2008	OM 542.962	D	<b>539</b>
2536, L, LL	04.2003 → 12.2008	OM 541.943	D	<b>514</b>	2555, L, LL	04.2003 →	OM 542.962	D	<b>539</b>
2536, L, LL	04.2003 → 12.2008	OM 541.972	D	<b>532</b>	2555, L, LL	04.2003 →	OM 542.962	D	<b>539</b>
2536, L, LL	04.2003 → 12.2008	OM 541.998	D	<b>530</b>	2558, L	04.2003 → 12.2008	OM 542.944	D	<b>519</b>
2536, L, LL	04.2003 →	OM 541.922	D	<b>514</b>	2560, L, LL	05.2005 → 12.2008	OM 542.964	D	<b>539</b>
2536, L, LL	04.2003 →	OM 541.942	D	<b>514</b>	2560, L, LL	05.2005 →	OM 542.964	D	<b>539</b>
2536, L, LL	04.2003 →	OM 541.943	D	<b>514</b>	2631 K, LK	04.2003 →	OM 541.920	D	<b>523</b>
2536, L, LL	04.2003 →	OM 541.972	D	<b>532</b>	2631 K, LK	04.2003 →	OM 541.940	D	<b>514</b>
2536, L, LL	04.2003 →	OM 541.998	D	<b>530</b>	2631 L	04.2003 →	OM 541.920	D	<b>523</b>
2541 LS	04.2003 →	OM 541.923	D	<b>514</b>	2631 L	04.2003 →	OM 541.940	D	<b>514</b>
2541 LS	04.2003 →	OM 541.923	D	<b>514</b>	2631 LS	10.2002 →	OM 541.920	D	<b>523</b>
2541 LS	04.2003 →	OM 541.944	D	<b>514</b>	2631 LS	10.2009 →	OM 541.920	D	<b>523</b>
2541 LS	04.2003 →	OM 541.944	D	<b>514</b>	2631 LS	10.2009 →	OM 541.940	D	<b>514</b>
2541 LS	04.2003 →	OM 541.990	D	<b>536</b>	2632 K, LK	04.2003 →	OM 541.940	D	<b>514</b>
2541 LS	06.2008 →	OM 541.974	D	<b>532</b>	2632 K, LK	04.2003 →	OM 541.970	D	<b>531</b>
2541, L, LL	04.2003 → 12.2008	OM 541.923	D	<b>514</b>	2632 K, LK	04.2003 →	OM 541.996	D	<b>530</b>
2541, L, LL	04.2003 → 12.2008	OM 541.944	D	<b>514</b>	2632 LS	04.2003 →	OM 541.940	D	<b>514</b>
2541, L, LL	04.2003 → 12.2008	OM 541.974	D	<b>532</b>	2632 LS	04.2003 →	OM 541.970	D	<b>531</b>
2541, L, LL	04.2003 → 12.2008	OM 541.990	D	<b>536</b>	2632 LS	04.2003 →	OM 541.996	D	<b>530</b>
2541, L, LL	04.2003 →	OM 541.923	D	<b>514</b>	2632 LS	10.2009 →	OM 541.970	D	<b>531</b>
2541, L, LL	04.2003 →	OM 541.944	D	<b>514</b>	2632 LS	10.2009 →	OM 541.996	D	<b>530</b>
2541, L, LL	04.2003 →	OM 541.974	D	<b>532</b>	2632, L, LL	04.2003 → 12.2008	OM 541.940	D	<b>514</b>
2541, L, LL	04.2003 →	OM 541.990	D	<b>536</b>	2632, L, LL	04.2003 → 12.2008	OM 541.970	D	<b>531</b>
2544 LS	04.2003 →	OM 541.925	D	<b>514</b>	2632, L, LL	04.2003 → 12.2008	OM 541.996	D	<b>530</b>
2544 LS	04.2003 →	OM 541.925	D	<b>514</b>	2635 K, LK	04.2003 →	OM 541.922	D	<b>514</b>
2544 LS	04.2003 →	OM 541.946	D	<b>514</b>	2635 K, LK	04.2003 →	OM 541.942	D	<b>514</b>
2544 LS	04.2003 →	OM 541.946	D	<b>514</b>	2635 L	04.2003 →	OM 541.922	D	<b>514</b>

M



# MERCEDES-BENZ

				Pos					Pos
2635 L	04.2003 →	OM 541.942	D	514	2648 LS	10.2002 →	OM 542.921	D	524
2635 LS	10.2002 →	OM 541.922	D	514	2648 LS	10.2009 →	OM 541.948	D	512
2635 LS	10.2002 →	OM 541.942	D	514	2648 S, LS	04.2003 →	OM 541.948	D	512
2635 LS	10.2009 →	OM 541.922	D	514	2648 S, LS	04.2003 →	OM 541.978	D	532
2635 LS	10.2009 →	OM 541.942	D	514	2648, L, LL	04.2003 →	OM 541.948	D	512
2636 K, LK	04.2003 →	OM 541.942	D	514	2648, L, LL	04.2003 →	OM 541.978	D	532
2636 K, LK	04.2003 →	OM 541.972	D	532	2650 K, 2651 K, LK	04.2003 → 12.2008	OM 542.940	D	519
2636 K, LK	04.2003 →	OM 541.998	D	530	2650 K, 2651 K, LK	05.2005 → 12.2008	OM 542.960	D	540
2636 LS	04.2003 → 12.2008	OM 541.942	D	514	2650 S, LS	04.2003 →	OM 542.940	D	519
2636 LS	04.2003 → 12.2008	OM 541.998	D	530	2650, L, 2651, L, LL	04.2003 → 12.2008	OM 542.940	D	519
2636 LS	02.2005 → 12.2008	OM 541.972	D	532	2651 L	05.2005 →	OM 542.960	D	540
2636 LS	10.2009 →	OM 541.972	D	532	2651 LS	10.2009 →	OM 542.960	D	540
2636 LS	10.2009 →	OM 541.998	D	530	2651 S, LS	05.2005 →	OM 542.960	D	540
2636, L, LL	04.2003 → 12.2008	OM 541.942	D	514	2653 K, LK	04.2003 →	OM 542.920	D	524
2636, L, LL	04.2003 → 12.2008	OM 541.972	D	532	2653 K, LK	04.2003 →	OM 542.942	D	519
2636, L, LL	04.2003 → 12.2008	OM 541.998	D	530	2653 L	04.2003 →	OM 542.920	D	524
2640 K, LK	04.2003 →	OM 541.923	D	514	2653 LS	10.2009 →	OM 542.920	D	524
2640 K, LK	04.2003 →	OM 541.944	D	514	2653 LS	10.2009 →	OM 542.942	D	519
2640 L	04.2003 →	OM 541.923	D	514	2654 K, LK, 2655 K, LK	04.2003 → 12.2008	OM 542.942	D	519
2640 L	04.2003 →	OM 541.944	D	514	2654 K, LK, 2655 K, LK	07.2005 → 12.2008	OM 542.962	D	539
2640 LS	10.2002 →	OM 541.944	D	514	2654 S, LS	04.2003 →	OM 542.920	D	524
2640 LS	10.2009 →	OM 541.923	D	514	2654 S, LS	04.2003 →	OM 542.942	D	519
2640 LS	10.2009 →	OM 541.944	D	514	2654, L, 2655, L, LL	04.2003 → 12.2008	OM 542.942	D	519
2641 K, LK	04.2003 →	OM 541.944	D	514	2654, L, 2655, L, LL	04.2003 → 12.2008	OM 542.962	D	539
2641 K, LK	04.2003 →	OM 541.974	D	532	2655 LS	10.2009 →	OM 542.962	D	539
2641 K, LK	04.2003 →	OM 541.990	D	536	2655 S, LS	04.2003 →	OM 542.962	D	539
2641 LS	10.2009 →	OM 541.974	D	532	2658 K, LK	04.2003 →	OM 542.944	D	519
2641 LS	10.2009 →	OM 541.990	D	536	2658 L	04.2003 → 12.2008	OM 542.944	D	519
2641 S, LS	04.2003 →	OM 541.944	D	514	2658 LS	04.2003 →	OM 542.944	D	519
2641 S, LS	04.2003 →	OM 541.974	D	532	2660 L, LL	05.2005 → 12.2008	OM 542.964	D	539
2641 S, LS	04.2003 →	OM 541.990	D	536	2660 LK	05.2005 →	OM 542.964	D	539
2641, L, LL	04.2003 → 12.2008	OM 541.974	D	532	2660 S, LS	06.2008 →	OM 542.964	D	539
2641, L, LL	04.2003 → 12.2008	OM 541.990	D	536	2665 LS	04.2003 →	OM 542.968	D	529
2641, L, LL	06.2003 → 12.2008	OM 541.944	D	514	2732 AE	06.2008 →	OM 541.941	D	514
2643 K, LK	04.2003 →	OM 541.925	D	514	2732 AE	06.2008 →	OM 541.997	D	530
2643 K, LK	04.2003 →	OM 541.946	D	514	2732 AKE	06.2008 →	OM 541.997	D	530
2643 L	04.2003 →	OM 541.925	D	514	2736 AE	06.2008 →	OM 541.943	D	514
2643 L	04.2003 →	OM 541.946	D	514	2736 AE	06.2008 →	OM 541.999	D	530
2643 LS	10.2009 →	OM 541.925	D	514	2736 AKE	06.2008 →	OM 541.943	D	514
2643 LS	10.2009 →	OM 541.946	D	514	2736 AKE	06.2008 →	OM 541.999	D	530
2643 LS	10.2009 →	OM 541.976	D	532	2741 AE	06.2008 →	OM 541.991	D	530
2643 LS	10.2009 →	OM 541.992	D	537	2741 AKE	06.2008 →	OM 541.991	D	530
2644 K, LK	04.2003 →	OM 541.946	D	514	2744 AE	06.2008 →	OM 541.947	D	514
2644 K, LK	04.2003 →	OM 541.976	D	532	2744 AE	06.2008 →	OM 541.993	D	537
2644 K, LK	04.2003 →	OM 541.992	D	537	2744 AKE	06.2008 →	OM 541.947	D	514
2644 S, LS	04.2003 →	OM 541.925	D	514	2744 AKE	06.2008 →	OM 541.993	D	537
2644 S, LS	04.2003 →	OM 541.946	D	514	2746 AE	06.2008 →	OM 541.949	D	512
2644 S, LS	04.2003 →	OM 541.976	D	532	2746 AE	06.2008 →	OM 541.995	D	538
2644 S, LS	04.2003 →	OM 541.992	D	537	2746 AKE	06.2008 →	OM 541.949	D	512
2644, L, LL	04.2003 → 12.2008	OM 541.976	D	532	2746 AKE	06.2008 →	OM 541.995	D	538
2644, L, LL	04.2003 → 12.2008	OM 541.992	D	537	2748 AE	06.2008 →	OM 541.949	D	512
2644, L, LL	06.2003 → 12.2008	OM 541.946	D	514	2748 AKE	06.2008 →	OM 541.949	D	512
2646 K, LK	04.2003 →	OM 541.948	D	512	3231 K, 3232 K	04.2003 → 12.2008	OM 541.920	D	523
2646 K, LK	04.2003 →	OM 541.980	D	534	3231 K, 3232 K	04.2003 → 12.2008	OM 541.940	D	514
2646 K, LK	04.2003 →	OM 541.994	D	537	3231 K, 3232 K	04.2003 → 12.2008	OM 541.970	D	531
2646 LS	10.2009 →	OM 541.948	D	512	3231 K, 3232 K	04.2003 → 12.2008	OM 541.996	D	530
2646 LS	10.2009 →	OM 541.994	D	537	3235 K	04.2003 →	OM 541.922	D	514
2646 S, LS	04.2003 →	OM 541.948	D	512	3235 K	04.2003 →	OM 541.942	D	514
2646 S, LS	04.2003 →	OM 541.980	D	534	3236 K	04.2003 → 12.2008	OM 541.972	D	532
2646 S, LS	04.2003 →	OM 541.994	D	537	3236 K	04.2003 → 12.2008	OM 541.998	D	530
2646, L, LL	04.2003 →	OM 541.948	D	512	3240	04.2003 →	OM 541.923	D	514
2646, L, LL	04.2003 →	OM 541.980	D	534	3240 K	04.2003 →	OM 541.923	D	514
2646, L, LL	04.2003 →	OM 541.994	D	537	3240 K	04.2003 →	OM 541.944	D	514
2648 K, LK	04.2003 → 12.2008	OM 541.948	D	512	3241	04.2003 → 12.2008	OM 541.944	D	514
2648 K, LK	04.2003 → 12.2008	OM 541.978	D	532	3241	04.2003 → 12.2008	OM 541.974	D	532
2648 K, LK	04.2003 →	OM 542.921	D	524	3241	04.2003 → 12.2008	OM 541.990	D	536
2648 K, LK	04.2003 →	OM 542.940	D	519	3241 K	04.2003 → 12.2008	OM 541.974	D	532
2648 L	04.2003 →	OM 542.921	D	524	3241 K	04.2003 → 12.2008	OM 541.990	D	536
2648 L	04.2003 →	OM 542.940	D	519	3241 L	06.2008 →	OM 541.944	D	514

M

			Pos				Pos		
3241 L	06.2008 →	OM 541.944	D	514	3339 AK	04.2003 →	OM 541.945	D	514
3243	10.2002 →	OM 541.925	D	514	3339 K	04.2003 →	OM 541.923	D	514
3243	10.2002 →	OM 541.946	D	514	3339 K	04.2003 →	OM 541.944	D	514
3243 K	04.2003 →	OM 541.925	D	514	3341	04.2003 → 12.2008	OM 541.944	D	514
3243 K	04.2003 →	OM 541.946	D	514	3341	04.2003 → 12.2008	OM 541.974	D	532
3244	04.2003 →	OM 541.976	D	532	3341	04.2003 → 12.2008	OM 541.990	D	536
3244	04.2003 →	OM 541.992	D	537	3341 A	04.2003 →	OM 541.991	D	530
3244 K	04.2003 →	OM 541.976	D	532	3341 AK	04.2003 →	OM 541.945	D	514
3244 K	04.2003 →	OM 541.992	D	537	3341 AK	04.2003 →	OM 541.975	D	533
3246	04.2003 → 12.2008	OM 541.948	D	512	3341 AK	04.2003 →	OM 541.991	D	530
3246	01.2040 → 12.2008	OM 541.980	D	534	3341 AKE	04.2003 →	OM 541.945	D	514
3246 K	04.2003 → 12.2003	OM 541.948	D	512	3341 AKE	04.2003 →	OM 541.991	D	530
3246 K	04.2003 → 12.2008	OM 541.980	D	534	3341 AS	04.2003 →	OM 541.944	D	514
3246 K	04.2003 → 12.2008	OM 541.994	D	537	3341 AS	04.2003 →	OM 541.945	D	514
3248 K	04.2003 →	OM 541.978	D	532	3341 AS	04.2003 →	OM 541.975	D	533
3248, L	04.2003 →	OM 541.978	D	532	3341 AS	04.2003 →	OM 541.991	D	530
3250	04.2003 →	OM 542.940	D	519	3341 K	04.2003 →	OM 541.974	D	532
3255 L	02.2009 →	OM 542.962	D	539	3341 K	04.2003 →	OM 541.990	D	536
3260 L	02.2009 →	OM 542.964	D	539	3341 S	04.2003 →	OM 541.923	D	514
3331 A, 3332 A	04.2003 →	OM 541.920	D	523	3341 S	04.2003 →	OM 541.944	D	514
3331 A, 3332 A	04.2003 →	OM 541.926	D	514	3341 S	04.2003 →	OM 541.974	D	532
3331 A, 3332 A	04.2003 →	OM 541.940	D	514	3341 S	04.2003 →	OM 541.990	D	536
3331 A, 3332 A	04.2003 →	OM 541.941	D	514	3343 AK	04.2003 →	OM 541.921	D	523
3331 A, 3332 A	04.2003 →	OM 541.971	D	532	3343 AK	04.2003 →	OM 541.947	D	514
3331 A, 3332 A	04.2003 →	OM 541.997	D	530	3343 K	04.2003 →	OM 541.925	D	514
3331 AK, 3332 AK	04.2003 →	OM 541.920	D	523	3343 K	04.2003 →	OM 541.946	D	514
3331 AK, 3332 AK	04.2003 →	OM 541.926	D	514	3344	04.2003 → 12.2008	OM 541.947	D	514
3331 AK, 3332 AK	04.2003 →	OM 541.940	D	514	3344	04.2003 → 12.2008	OM 541.992	D	537
3331 K	04.2003 →	OM 541.920	D	523	3344	06.2003 → 12.2008	OM 541.946	D	514
3331 K	04.2003 →	OM 541.940	D	514	3344 A	04.2003 →	OM 541.921	D	523
3331 S, 3332 S	04.2003 → 12.2008	OM 541.920	D	523	3344 A	04.2003 →	OM 541.946	D	514
3331 S, 3332 S	04.2003 → 12.2008	OM 541.940	D	514	3344 A	04.2003 →	OM 541.947	D	514
3331 S, 3332 S	02.2005 → 12.2008	OM 541.970	D	531	3344 A	04.2003 →	OM 541.977	D	533
3331, 3332	04.2003 →	OM 541.920	D	523	3344 A	04.2003 →	OM 541.993	D	537
3331, 3332	04.2003 →	OM 541.940	D	514	3344 AK	04.2003 →	OM 541.947	D	514
3332 AK	04.2003 →	OM 541.941	D	514	3344 AK	04.2003 →	OM 541.977	D	533
3332 AK	04.2003 →	OM 541.997	D	530	3344 AK	04.2003 →	OM 541.993	D	537
3332 AKE	04.2003 →	OM 541.997	D	530	3344 AKE	04.2003 →	OM 541.947	D	514
3332 AS	04.2003 →	OM 541.941	D	514	3344 AKE	04.2003 →	OM 541.993	D	537
3332 K	04.2003 → 12.2008	OM 541.920	D	523	3344 AS	04.2003 →	OM 541.947	D	514
3332 K	04.2003 → 12.2008	OM 541.940	D	514	3344 AS	04.2003 →	OM 541.977	D	533
3332 K	04.2003 → 12.2008	OM 541.970	D	531	3344 K	04.2003 →	OM 541.976	D	532
3332 K	04.2003 → 12.2008	OM 541.996	D	530	3344 K	04.2003 →	OM 541.992	D	537
3335 A	04.2003 →	OM 541.927	D	514	3344 S	04.2003 → 12.2008	OM 541.946	D	514
3335 A	04.2003 →	OM 541.943	D	514	3344 S	04.2003 → 12.2008	OM 541.992	D	537
3335 K	04.2003 →	OM 541.922	D	514	3344 S	02.2005 → 12.2008	OM 541.976	D	532
3336	04.2003 → 12.2008	OM 541.942	D	514	3346	04.2003 →	OM 541.948	D	512
3336	04.2003 → 12.2008	OM 541.972	D	532	3346 A	04.2003 →	OM 541.949	D	512
3336 A	04.2003 →	OM 541.942	D	514	3346 A	04.2003 →	OM 541.995	D	538
3336 A	04.2003 →	OM 541.943	D	514	3346 AK	04.2003 →	OM 541.949	D	512
3336 A	04.2003 →	OM 541.973	D	532	3346 AK	04.2003 →	OM 541.995	D	538
3336 A	04.2003 →	OM 541.999	D	530	3346 AKE	04.2003 →	OM 541.949	D	512
3336 AK	04.2003 →	OM 541.927	D	514	3346 AKE	04.2003 →	OM 541.995	D	538
3336 AK	04.2003 →	OM 541.943	D	514	3346 AS	04.2003 →	OM 541.949	D	512
3336 AK	04.2003 →	OM 541.973	D	532	3346 AS	04.2003 →	OM 541.981	D	535
3336 AK	04.2003 →	OM 541.999	D	530	3346 K	04.2003 →	OM 541.948	D	512
3336 AKE	04.2003 →	OM 541.927	D	514	3346 K	04.2003 →	OM 541.980	D	534
3336 AKE	04.2003 →	OM 541.943	D	514	3346 K	04.2003 →	OM 541.994	D	537
3336 AS	04.2003 →	OM 541.943	D	514	3346 S	04.2003 →	OM 541.948	D	512
3336 AS	04.2003 →	OM 541.973	D	532	3348	04.2003 →	OM 541.978	D	532
3336 K	04.2003 →	OM 541.942	D	514	3348	04.2003 →	OM 542.921	D	524
3336 K	04.2003 →	OM 541.942	D	514	3348 A	04.2003 →	OM 541.949	D	512
3336 K	04.2003 →	OM 541.972	D	532	3348 AK	04.2003 → 12.2008	OM 541.948	D	512
3336 K	04.2003 →	OM 541.998	D	530	3348 AK	04.2003 →	OM 542.925	D	525
3336 S	04.2003 →	OM 541.942	D	514	3348 AKE	04.2003 →	OM 541.949	D	512
3336 S	04.2003 →	OM 541.972	D	532	3348 AS	04.2003 →	OM 541.948	D	512
3339 A	04.2003 →	OM 541.924	D	514	3348 AS	04.2003 →	OM 542.925	D	525
3339 A	04.2003 →	OM 541.945	D	514	3348 K	04.2003 →	OM 541.978	D	532
3339 AK	04.2003 →	OM 541.924	D	514	3348 K	04.2003 →	OM 542.921	D	524



			Pos				Pos		
3348 S	04.2003 →	OM 541.948	D	512	4150 AK	04.2003 →	OM 542.941	D	519
3348 S	04.2003 →	OM 542.921	D	524	4150 K	04.2003 → 12.2008	OM 542.940	D	519
3350 S	06.2009 →	OM 542.940	D	519	4150 K	04.2003 →	OM 542.941	D	519
3350, 3351	04.2003 → 12.2008	OM 542.940	D	519	4151 AK	05.2005 →	OM 542.961	D	539
3350, 3351	05.2005 → 12.2008	OM 542.960	D	540	4151 K	05.2005 → 12.2008	OM 542.960	D	540
3351 A	06.2008 →	OM 542.961	D	539	4151 K	05.2005 →	OM 542.961	D	539
3351 AK	04.2003 → 12.2008	OM 542.941	D	519	4154 S	04.2003 →	OM 542.942	D	519
3351 AK	05.2005 → 12.2008	OM 542.961	D	539	4155 AK	04.2003 →	OM 542.963	D	528
3351 AS	04.2003 →	OM 542.941	D	519	4155 K	04.2003 →	OM 542.962	D	539
3351 AS	05.2005 →	OM 542.961	D	539	4160 AK	04.2003 →	OM 542.965	D	528
3351 K	04.2003 →	OM 542.940	D	519	4160 K	05.2005 →	OM 542.964	D	539
3351 K	05.2005 →	OM 542.960	D	540	4160 S	10.2002 →	OM 542.956	D	510
3351 S	04.2003 →	OM 542.940	D	519	4160 S	10.2002 →	OM 542.957	D	510
3351 S	05.2005 →	OM 542.960	D	540	4160 SLT	11.2002 →	OM 542.956	D	510
3354, 3355	04.2003 → 12.2008	OM 542.942	D	519	4165 AK	04.2003 →	OM 542.968	D	529
3354, 3355	04.2003 → 12.2008	OM 542.962	D	539	4165 AK	04.2003 →	OM 542.969	D	529
3355 A	04.2003 →	OM 542.963	D	528	4165 S	08.2008 →	OM 542.968	D	529
3355 AK	04.2003 →	OM 542.963	D	528	4165 S	08.2008 →	OM 542.969	D	529
3355 AS	04.2003 →	OM 542.963	D	528	4843 K	09.2015 →	OM 541.920	D	523
3355 S	04.2003 →	OM 542.962	D	539	4844 K	08.2009 →	OM 541.992	D	537
3358	04.2003 → 12.2008	OM 542.944	D	519	5041 AK	06.2008 →	OM 541.991	D	530
3360	05.2005 →	OM 542.964	D	539	5041 K	06.2008 →	OM 541.923	D	514
3360 A	04.2003 →	OM 542.965	D	528	5041 K	06.2008 →	OM 541.944	D	514
3360 AK	04.2003 →	OM 542.965	D	528	5041 K	06.2008 →	OM 541.974	D	532
3365 A	04.2003 →	OM 542.968	D	529	5041 K	06.2008 →	OM 541.990	D	536
3365 A	04.2003 →	OM 542.969	D	529	5044 AK	06.2008 →	OM 541.947	D	514
3550 S	06.2009 →	OM 542.940	D	519	5044 AK	06.2008 →	OM 541.993	D	537
4036 K	06.2009 →	OM 541.942	D	514	5044 K	06.2008 →	OM 541.946	D	514
4036 K	06.2009 →	OM 541.972	D	532	5044 K	06.2008 →	OM 541.976	D	532
4036 K	06.2009 →	OM 541.998	D	530	5044 K	06.2008 →	OM 541.992	D	537
4140 AK	04.2003 →	OM 541.923	D	514	5046 AK	06.2008 →	OM 541.949	D	512
4140 AK	04.2003 →	OM 541.924	D	514	5046 K	06.2008 →	OM 541.948	D	512
4140 AK	04.2003 →	OM 541.944	D	514	5046 K	06.2008 →	OM 541.980	D	534
4140 AK	04.2003 →	OM 541.945	D	514	5046 K	06.2008 →	OM 541.994	D	537
4140 K	04.2003 →	OM 541.923	D	514	5048 AK	06.2008 →	OM 541.949	D	512
4140 K	04.2003 →	OM 541.923	D	514	<b>ACTROS MP4 / MP5</b>				
4140 K	04.2003 →	OM 541.924	D	514	1824 L	07.2011 →	OM 936.912	D	316
4140 K	04.2003 →	OM 541.944	D	514	1824 L	05.2013 →	OM 936.912	D	316
4140 K	04.2003 →	OM 541.944	D	514	1824 LS	07.2011 →	OM 936.912	D	316
4140 K	04.2003 →	OM 541.945	D	514	1824 LS	05.2013 →	OM 936.912	D	316
4141	06.2008 →	OM 541.944	D	514	1827 L	07.2011 →	OM 936.912	D	316
4141 AK	04.2003 →	OM 541.991	D	530	1827 L	05.2013 →	OM 936.912	D	316
4141 K	04.2003 → 12.2008	OM 541.990	D	536	1827 LS	07.2011 →	OM 936.912	D	316
4141 K	04.2003 →	OM 541.991	D	530	1827 LS	05.2013 →	OM 936.912	D	316
4141 K	02.2005 → 12.2008	OM 541.974	D	532	1830 L	07.2011 →	OM 936.912	D	316
4143 AK	04.2003 →	OM 541.921	D	523	1830 L	05.2013 →	OM 936.912	D	316
4143 K	04.2003 →	OM 541.921	D	523	1830 LS	07.2011 →	OM 936.912	D	316
4143 K	04.2003 →	OM 541.947	D	514	1830 LS	05.2013 →	OM 936.912	D	316
4144 AK	04.2003 →	OM 541.947	D	514	1832 L	07.2011 →	OM 936.916	D	316
4144 AK	04.2003 →	OM 541.993	D	537	1832 L	05.2013 →	OM 936.916	D	316
4144 K	04.2003 → 12.2008	OM 541.925	D	514	1832 LS	07.2011 →	OM 936.916	D	316
4144 K	04.2003 → 12.2008	OM 541.976	D	532	1832 LS	05.2013 →	OM 936.916	D	316
4144 K	04.2003 →	OM 541.976	D	532	1833 L	07.2011 →	OM 470.906	D	341
4144 K	04.2003 →	OM 541.976	D	532	1833 L	05.2013 →	OM 470.906	D	341
4144 K	04.2003 →	OM 541.992	D	537	1833 L	05.2013 →	OM 470.910	D	341
4144 K	04.2003 →	OM 541.993	D	537	1833 L	05.2013 →	OM 470.913	D	341
4144 K	06.2003 → 12.2008	OM 541.946	D	514	1833 LS	07.2011 →	OM 470.906	D	341
4146 AK	04.2003 →	OM 541.949	D	512	1833 LS	05.2013 →	OM 470.906	D	341
4146 K	04.2003 →	OM 541.948	D	512	1833 LS	05.2013 →	OM 470.910	D	341
4146 K	04.2003 →	OM 541.949	D	512	1833 LS	05.2013 →	OM 470.913	D	341
4146 K	04.2003 →	OM 541.980	D	534	1835 L	07.2011 →	OM 936.916	D	316
4146 K	04.2003 →	OM 541.994	D	537	1835 L	05.2013 →	OM 936.916	D	316
4148 AK	04.2003 →	OM 541.948	D	512	1835 LS	07.2011 →	OM 936.916	D	316
4148 AK	04.2003 →	OM 542.925	D	525	1835 LS	05.2013 →	OM 936.916	D	316
4148 K	04.2003 → 12.2008	OM 541.948	D	512	1836 L	07.2011 →	OM 470.906	D	341
4148 K	04.2003 → 12.2008	OM 541.978	D	532	1836 L	05.2013 →	OM 470.906	D	341
4148 K	04.2003 →	OM 541.949	D	512	1836 L	05.2013 →	OM 470.910	D	341
4148 K	04.2003 →	OM 542.921	D	524	1836 L	05.2013 →	OM 470.913	D	341
4148 K	04.2003 →	OM 542.925	D	525	1836 LS	07.2011 →	OM 470.906	D	341

M

				Pos					Pos
1836 LS	05.2013 →	OM 470.906	D	341	1851 LS	05.2013 →	OM 471.922	D	557
1836 LS	05.2013 →	OM 470.910	D	341	1851 LS	05.2013 →	OM 471.926	D	558
1836 LS	05.2013 →	OM 470.913	D	341	1852 L	05.2013 →	OM 473.900	D	567
1840 L	07.2011 →	OM 470.906	D	341	1852 L	05.2013 →	OM 473.907	D	568
1840 L	05.2013 →	OM 470.906	D	341	1852 L	05.2013 →	OM 473.909	D	569
1840 L	05.2013 →	OM 470.910	D	341	1852 L	01.2014 →	OM 473.900	D	567
1840 L	05.2013 →	OM 470.913	D	341	1852 LS	05.2013 →	OM 473.900	D	567
1840 LS	07.2011 →	OM 470.906	D	341	1852 LS	05.2013 →	OM 473.907	D	568
1840 LS	05.2013 →	OM 470.906	D	341	1852 LS	05.2013 →	OM 473.909	D	569
1840 LS	05.2013 →	OM 470.910	D	341	1852 LS	05.2013 →	OM 473.915	D	568
1840 LS	05.2013 →	OM 470.913	D	341	1852 LS	01.2014 →	OM 473.900	D	567
1842 L	07.2011 →	OM 471.900	D	556	1853 L	07.2015 →	OM 471.922	D	557
1842 L	07.2011 →	OM 471.909	D	556	1853 L	07.2015 →	OM 471.922	D	557
1842 L	05.2013 →	OM 471.900	D	556	1853 L	07.2015 →	OM 471.926	D	558
1842 L	05.2013 →	OM 471.909	D	556	1853 L	07.2015 →	OM 471.926	D	558
1842 L	05.2013 →	OM 471.922	D	557	1853 LS	07.2015 →	OM 471.922	D	557
1842 L	05.2013 →	OM 471.926	D	558	1853 LS	07.2015 →	OM 471.922	D	557
1842 LS	07.2011 →	OM 471.900	D	556	1853 LS	07.2015 →	OM 471.926	D	558
1842 LS	07.2011 →	OM 471.909	D	556	1853 LS	07.2015 →	OM 471.926	D	558
1842 LS	05.2013 →	OM 471.900	D	556	1858 L	05.2013 →	OM 473.900	D	567
1842 LS	05.2013 →	OM 471.909	D	556	1858 L	05.2013 →	OM 473.907	D	568
1842 LS	05.2013 →	OM 471.922	D	557	1858 L	05.2013 →	OM 473.909	D	569
1842 LS	05.2013 →	OM 471.926	D	558	1858 L	01.2014 →	OM 473.905	D	567
1843 L	07.2011 →	OM 470.906	D	341	1858 LS	05.2013 →	OM 473.900	D	567
1843 L	05.2013 →	OM 470.906	D	341	1858 LS	05.2013 →	OM 473.907	D	568
1843 L	05.2013 →	OM 470.910	D	341	1858 LS	05.2013 →	OM 473.909	D	569
1843 L	05.2013 →	OM 470.913	D	341	1858 LS	05.2013 →	OM 473.915	D	568
1843 LS	07.2011 →	OM 470.906	D	341	1858 LS	01.2014 →	OM 473.905	D	567
1843 LS	05.2013 →	OM 470.906	D	341	1863 L	05.2013 →	OM 473.900	D	567
1843 LS	05.2013 →	OM 470.910	D	341	1863 L	05.2013 →	OM 473.907	D	568
1843 LS	05.2013 →	OM 470.913	D	341	1863 L	05.2013 →	OM 473.909	D	569
1845 L	07.2011 →	OM 471.900	D	556	1863 L	01.2014 →	OM 473.903	D	567
1845 L	07.2011 →	OM 471.909	D	556	1863 LS	05.2013 →	OM 473.900	D	567
1845 L	05.2013 →	OM 471.900	D	556	1863 LS	05.2013 →	OM 473.907	D	568
1845 L	05.2013 →	OM 471.909	D	556	1863 LS	05.2013 →	OM 473.909	D	569
1845 L	05.2013 →	OM 471.922	D	557	1863 LS	05.2013 →	OM 473.915	D	568
1845 L	05.2013 →	OM 471.926	D	558	1863 LS	01.2014 →	OM 473.903	D	567
1845 LS	07.2011 →	OM 471.900	D	556	2024 L	07.2011 →	OM 936.912	D	316
1845 LS	07.2011 →	OM 471.909	D	556	2024 L	05.2013 →	OM 936.912	D	316
1845 LS	05.2013 →	OM 471.900	D	556	2024 LS	07.2011 →	OM 936.912	D	316
1845 LS	05.2013 →	OM 471.909	D	556	2024 LS	05.2013 →	OM 936.912	D	316
1845 LS	05.2013 →	OM 471.922	D	557	2027 L	07.2011 →	OM 936.912	D	316
1845 LS	05.2013 →	OM 471.926	D	558	2027 L	05.2013 →	OM 936.912	D	316
1846 L	07.2015 →	OM 470.910	D	341	2027 LS	07.2011 →	OM 936.912	D	316
1846 L	07.2015 →	OM 470.910	D	341	2027 LS	05.2013 →	OM 936.912	D	316
1846 L	07.2015 →	OM 470.913	D	341	2030 L	07.2011 →	OM 936.912	D	316
1846 L	07.2015 →	OM 470.913	D	341	2030 L	05.2013 →	OM 936.912	D	316
1846 LS	07.2015 →	OM 470.910	D	341	2030 LS	07.2011 →	OM 936.912	D	316
1846 LS	07.2015 →	OM 470.910	D	341	2030 LS	05.2013 →	OM 936.912	D	316
1846 LS	07.2015 →	OM 470.913	D	341	2032 L	07.2011 →	OM 936.916	D	316
1846 LS	07.2015 →	OM 470.913	D	341	2032 L	05.2013 →	OM 936.916	D	316
1848 L	07.2011 →	OM 471.900	D	556	2032 LS	07.2011 →	OM 936.916	D	316
1848 L	05.2013 →	OM 471.900	D	556	2032 LS	05.2013 →	OM 936.916	D	316
1848 L	05.2013 →	OM 471.922	D	557	2033 L	07.2011 →	OM 470.906	D	341
1848 L	05.2013 →	OM 471.926	D	558	2033 L	05.2013 →	OM 470.906	D	341
1848 LS	07.2011 →	OM 471.900	D	556	2033 L	05.2013 →	OM 470.910	D	341
1848 LS	05.2013 →	OM 471.900	D	556	2033 L	05.2013 →	OM 470.913	D	341
1848 LS	05.2013 →	OM 471.922	D	557	2033 LS	07.2011 →	OM 470.906	D	341
1848 LS	05.2013 →	OM 471.926	D	558	2033 LS	05.2013 →	OM 470.906	D	341
1851 L	07.2011 →	OM 471.900	D	556	2033 LS	05.2013 →	OM 470.910	D	341
1851 L	07.2011 →	OM 471.909	D	556	2033 LS	05.2013 →	OM 470.913	D	341
1851 L	05.2013 →	OM 471.900	D	556	2035 L	07.2011 →	OM 936.916	D	316
1851 L	05.2013 →	OM 471.909	D	556	2035 L	05.2013 →	OM 936.916	D	316
1851 L	05.2013 →	OM 471.922	D	557	2035 LS	07.2011 →	OM 936.916	D	316
1851 L	05.2013 →	OM 471.926	D	558	2035 LS	05.2013 →	OM 936.916	D	316
1851 LS	07.2011 →	OM 471.900	D	556	2036 L	07.2011 →	OM 470.906	D	341
1851 LS	07.2011 →	OM 471.909	D	556	2036 L	05.2013 →	OM 470.906	D	341
1851 LS	05.2013 →	OM 471.900	D	556	2036 L	05.2013 →	OM 470.910	D	341
1851 LS	05.2013 →	OM 471.909	D	556	2036 L	05.2013 →	OM 470.913	D	341

M

				Pos					Pos
2036 LS	07.2011 →	OM 470.906	D	341	2051 LS	05.2013 →	OM 471.900	D	556
2036 LS	05.2013 →	OM 470.906	D	341	2051 LS	05.2013 →	OM 471.909	D	556
2036 LS	05.2013 →	OM 470.910	D	341	2051 LS	05.2013 →	OM 471.922	D	557
2036 LS	05.2013 →	OM 470.913	D	341	2051 LS	05.2013 →	OM 471.926	D	558
2040 L	07.2011 →	OM 470.906	D	341	2052 L	07.2011 →	OM 473.900	D	567
2040 L	05.2013 →	OM 470.906	D	341	2052 L	07.2011 →	OM 473.907	D	568
2040 L	05.2013 →	OM 470.910	D	341	2052 L	07.2011 →	OM 473.909	D	569
2040 L	05.2013 →	OM 470.913	D	341	2052 L	05.2013 →	OM 473.900	D	567
2040 LS	07.2011 →	OM 470.906	D	341	2052 L	05.2013 →	OM 473.907	D	568
2040 LS	05.2013 →	OM 470.906	D	341	2052 L	05.2013 →	OM 473.909	D	569
2040 LS	05.2013 →	OM 470.910	D	341	2052 LS	07.2011 →	OM 473.900	D	567
2040 LS	05.2013 →	OM 470.913	D	341	2052 LS	07.2011 →	OM 473.907	D	568
2042 L	07.2011 →	OM 471.900	D	556	2052 LS	07.2011 →	OM 473.909	D	569
2042 L	07.2011 →	OM 471.909	D	556	2052 LS	05.2013 →	OM 473.900	D	567
2042 L	05.2013 →	OM 471.900	D	556	2052 LS	05.2013 →	OM 473.907	D	568
2042 L	05.2013 →	OM 471.909	D	556	2052 LS	05.2013 →	OM 473.909	D	569
2042 L	05.2013 →	OM 471.922	D	557	2053 L	07.2015 →	OM 471.922	D	557
2042 L	05.2013 →	OM 471.926	D	558	2053 L	07.2015 →	OM 471.922	D	557
2042 LS	07.2011 →	OM 471.900	D	556	2053 L	07.2015 →	OM 471.926	D	558
2042 LS	07.2011 →	OM 471.909	D	556	2053 L	07.2015 →	OM 471.926	D	558
2042 LS	05.2013 →	OM 471.900	D	556	2053 LS	07.2015 →	OM 471.922	D	557
2042 LS	05.2013 →	OM 471.909	D	556	2053 LS	07.2015 →	OM 471.922	D	557
2042 LS	05.2013 →	OM 471.922	D	557	2053 LS	07.2015 →	OM 471.926	D	558
2042 LS	05.2013 →	OM 471.926	D	558	2053 LS	07.2015 →	OM 471.926	D	558
2043 L	07.2011 →	OM 470.906	D	341	2058 L	07.2011 →	OM 473.900	D	567
2043 L	05.2013 →	OM 470.906	D	341	2058 L	07.2011 →	OM 473.907	D	568
2043 L	05.2013 →	OM 470.910	D	341	2058 L	07.2011 →	OM 473.909	D	569
2043 L	05.2013 →	OM 470.913	D	341	2058 L	05.2013 →	OM 473.900	D	567
2043 LS	07.2011 →	OM 470.906	D	341	2058 L	05.2013 →	OM 473.907	D	568
2043 LS	05.2013 →	OM 470.906	D	341	2058 L	05.2013 →	OM 473.909	D	569
2043 LS	05.2013 →	OM 470.910	D	341	2058 LS	07.2011 →	OM 473.900	D	567
2043 LS	05.2013 →	OM 470.913	D	341	2058 LS	07.2011 →	OM 473.907	D	568
2045 L	07.2011 →	OM 471.900	D	556	2058 LS	07.2011 →	OM 473.909	D	569
2045 L	07.2011 →	OM 471.909	D	556	2058 LS	05.2013 →	OM 473.900	D	567
2045 L	05.2013 →	OM 471.900	D	556	2058 LS	05.2013 →	OM 473.907	D	568
2045 L	05.2013 →	OM 471.909	D	556	2058 LS	05.2013 →	OM 473.909	D	569
2045 L	05.2013 →	OM 471.922	D	557	2063 L	07.2011 →	OM 473.900	D	567
2045 L	05.2013 →	OM 471.926	D	558	2063 L	07.2011 →	OM 473.907	D	568
2045 LS	07.2011 →	OM 471.900	D	556	2063 L	07.2011 →	OM 473.909	D	569
2045 LS	07.2011 →	OM 471.909	D	556	2063 L	05.2013 →	OM 473.900	D	567
2045 LS	05.2013 →	OM 471.900	D	556	2063 L	05.2013 →	OM 473.907	D	568
2045 LS	05.2013 →	OM 471.909	D	556	2063 L	05.2013 →	OM 473.909	D	569
2045 LS	05.2013 →	OM 471.922	D	557	2063 LS	07.2011 →	OM 473.900	D	567
2045 LS	05.2013 →	OM 471.926	D	558	2063 LS	07.2011 →	OM 473.907	D	568
2045 LS	01.2019 →	OM 460.984	D	465	2063 LS	07.2011 →	OM 473.909	D	569
2046 L	07.2015 →	OM 470.910	D	341	2063 LS	05.2013 →	OM 473.900	D	567
2046 L	07.2015 →	OM 470.910	D	341	2063 LS	05.2013 →	OM 473.907	D	568
2046 L	07.2015 →	OM 470.913	D	341	2063 LS	05.2013 →	OM 473.909	D	569
2046 L	07.2015 →	OM 470.913	D	341	2424 LS	07.2011 →	OM 936.912	D	316
2046 LS	07.2015 →	OM 470.910	D	341	2427 LS	07.2011 →	OM 936.912	D	316
2046 LS	07.2015 →	OM 470.910	D	341	2427 LS	07.2011 →	OM 936.912	D	316
2046 LS	07.2015 →	OM 470.913	D	341	2430 LS	07.2011 →	OM 936.912	D	316
2046 LS	07.2015 →	OM 470.913	D	341	2430 LS	05.2013 →	OM 936.912	D	316
2048 L	07.2011 →	OM 471.900	D	556	2432 LS	07.2011 →	OM 936.916	D	316
2048 L	05.2013 →	OM 471.900	D	556	2432 LS	07.2011 →	OM 936.916	D	316
2048 L	05.2013 →	OM 471.922	D	557	2433 LS	07.2011 →	OM 470.906	D	341
2048 L	05.2013 →	OM 471.926	D	558	2433 LS	07.2011 →	OM 470.906	D	341
2048 LS	07.2011 →	OM 471.900	D	556	2435 LS	07.2011 →	OM 936.916	D	316
2048 LS	05.2013 →	OM 471.900	D	556	2435 LS	07.2011 →	OM 936.916	D	316
2048 LS	05.2013 →	OM 471.922	D	557	2436 LS	07.2011 →	OM 470.906	D	341
2048 LS	05.2013 →	OM 471.926	D	558	2436 LS	07.2011 →	OM 470.906	D	341
2051 L	07.2011 →	OM 471.900	D	556	2440 LS	07.2011 →	OM 470.906	D	341
2051 L	07.2011 →	OM 471.909	D	556	2440 LS	07.2011 →	OM 470.906	D	341
2051 L	05.2013 →	OM 471.900	D	556	2442 LS	07.2011 →	OM 471.900	D	556
2051 L	05.2013 →	OM 471.909	D	556	2442 LS	07.2011 →	OM 471.900	D	556
2051 L	05.2013 →	OM 471.922	D	557	2442 LS	07.2011 →	OM 471.909	D	556
2051 L	05.2013 →	OM 471.926	D	558	2442 LS	07.2011 →	OM 471.909	D	556
2051 LS	07.2011 →	OM 471.900	D	556	2443 LS	07.2011 →	OM 470.906	D	341
2051 LS	07.2011 →	OM 471.909	D	556	2443 LS	07.2011 →	OM 470.906	D	341

M











				Pos					Pos
2636 LS	07.2011 →	OM 470.906	D	341	2646 LS	07.2015 →	OM 470.913	D	341
2636 LS	07.2011 →	OM 470.906	D	341	2646 LS	07.2015 →	OM 470.913	D	341
2636 LS	05.2013 →	OM 470.906	D	341	2646 LS	07.2015 →	OM 470.913	D	341
2636 LS	05.2013 →	OM 470.910	D	341	2646 LS	07.2011 →	OM 471.900	D	556
2636 LS	05.2013 →	OM 470.913	D	341	2648 L	07.2011 →	OM 471.900	D	556
2640 L	07.2011 →	OM 470.906	D	341	2648 L	05.2013 →	OM 471.900	D	556
2640 L	07.2011 →	OM 470.906	D	341	2648 L	05.2013 →	OM 471.922	D	557
2640 L	05.2013 →	OM 470.906	D	341	2648 L	05.2013 →	OM 471.926	D	558
2640 L	05.2013 →	OM 470.910	D	341	2648 LS	07.2011 →	OM 471.900	D	556
2640 L	05.2013 →	OM 470.913	D	341	2648 LS	07.2011 →	OM 471.900	D	556
2640 LS	07.2011 →	OM 470.906	D	341	2648 LS	05.2013 →	OM 471.900	D	556
2640 LS	07.2011 →	OM 470.906	D	341	2648 LS	05.2013 →	OM 471.922	D	557
2640 LS	05.2013 →	OM 470.906	D	341	2648 LS	05.2013 →	OM 471.926	D	558
2640 LS	05.2013 →	OM 470.910	D	341	2651 L	07.2011 →	OM 471.900	D	556
2640 LS	05.2013 →	OM 470.913	D	341	2651 L	07.2011 →	OM 471.900	D	556
2642 L	07.2011 →	OM 471.900	D	556	2651 L	07.2011 →	OM 471.909	D	556
2642 L	07.2011 →	OM 471.900	D	556	2651 L	05.2013 →	OM 471.900	D	556
2642 L	07.2011 →	OM 471.909	D	556	2651 L	05.2013 →	OM 471.909	D	556
2642 L	07.2011 →	OM 471.909	D	556	2651 L	05.2013 →	OM 471.922	D	557
2642 L	05.2013 →	OM 471.900	D	556	2651 L	05.2013 →	OM 471.926	D	558
2642 L	05.2013 →	OM 471.909	D	556	2651 LS	07.2011 →	OM 471.900	D	556
2642 L	05.2013 →	OM 471.922	D	557	2651 LS	07.2011 →	OM 471.900	D	556
2642 L	05.2013 →	OM 471.926	D	558	2651 LS	07.2011 →	OM 471.909	D	556
2642 LS	07.2011 →	OM 471.900	D	556	2651 LS	07.2011 →	OM 471.909	D	556
2642 LS	07.2011 →	OM 471.900	D	556	2651 LS	05.2013 →	OM 471.900	D	556
2642 LS	07.2011 →	OM 471.909	D	556	2651 LS	05.2013 →	OM 471.909	D	556
2642 LS	07.2011 →	OM 471.909	D	556	2651 LS	05.2013 →	OM 471.922	D	557
2642 LS	05.2013 →	OM 471.900	D	556	2651 LS	05.2013 →	OM 471.926	D	558
2642 LS	05.2013 →	OM 471.909	D	556	2651 LS	04.2017 →	OM 460.953	D	465
2642 LS	05.2013 →	OM 471.922	D	557	2652 L	07.2011 →	OM 473.900	D	567
2642 LS	05.2013 →	OM 471.926	D	558	2652 L	07.2011 →	OM 473.900	D	567
2643 L	07.2011 →	OM 470.906	D	341	2652 L	07.2011 →	OM 473.907	D	568
2643 L	07.2011 →	OM 470.906	D	341	2652 L	07.2011 →	OM 473.907	D	568
2643 L	05.2013 →	OM 470.906	D	341	2652 L	07.2011 →	OM 473.909	D	569
2643 L	05.2013 →	OM 470.910	D	341	2652 L	07.2011 →	OM 473.909	D	569
2643 L	05.2013 →	OM 470.913	D	341	2652 L	05.2013 →	OM 473.900	D	567
2643 LS	07.2011 →	OM 470.906	D	341	2652 L	05.2013 →	OM 473.907	D	568
2643 LS	07.2011 →	OM 470.906	D	341	2652 L	05.2013 →	OM 473.909	D	569
2643 LS	05.2013 →	OM 470.906	D	341	2652 LS	07.2011 →	OM 473.900	D	567
2643 LS	05.2013 →	OM 470.910	D	341	2652 LS	07.2011 →	OM 473.900	D	567
2643 LS	05.2013 →	OM 470.913	D	341	2652 LS	07.2011 →	OM 473.907	D	568
2645 L	07.2011 →	OM 471.900	D	556	2652 LS	07.2011 →	OM 473.907	D	568
2645 L	07.2011 →	OM 471.900	D	556	2652 LS	07.2011 →	OM 473.909	D	569
2645 L	07.2011 →	OM 471.909	D	556	2652 LS	07.2011 →	OM 473.909	D	569
2645 L	07.2011 →	OM 471.909	D	556	2652 LS	05.2013 →	OM 473.900	D	567
2645 L	05.2013 →	OM 471.900	D	556	2652 LS	05.2013 →	OM 473.907	D	568
2645 L	05.2013 →	OM 471.909	D	556	2652 LS	05.2013 →	OM 473.909	D	569
2645 L	05.2013 →	OM 471.922	D	557	2653 L	07.2015 →	OM 471.922	D	557
2645 L	05.2013 →	OM 471.926	D	558	2653 L	07.2015 →	OM 471.922	D	557
2645 LS	07.2011 →	OM 471.900	D	556	2653 L	07.2015 →	OM 471.926	D	558
2645 LS	07.2011 →	OM 471.900	D	556	2653 L	07.2015 →	OM 471.926	D	558
2645 LS	07.2011 →	OM 471.909	D	556	2653 L	07.2015 →	OM 471.926	D	558
2645 LS	07.2011 →	OM 471.909	D	556	2653 L	07.2015 →	OM 471.926	D	558
2645 LS	05.2013 →	OM 471.900	D	556	2653 LS	07.2015 →	OM 471.922	D	557
2645 LS	05.2013 →	OM 471.909	D	556	2653 LS	07.2015 →	OM 471.922	D	557
2645 LS	05.2013 →	OM 471.922	D	557	2653 LS	07.2015 →	OM 471.922	D	557
2645 LS	05.2013 →	OM 471.926	D	558	2653 LS	07.2015 →	OM 471.926	D	558
2646 L	07.2015 →	OM 470.910	D	341	2653 LS	07.2015 →	OM 471.926	D	558
2646 L	07.2015 →	OM 470.910	D	341	2653 LS	07.2015 →	OM 471.926	D	558
2646 L	07.2015 →	OM 470.913	D	341	2653 S	01.2020 →	OM 471.922	D	557
2646 L	07.2015 →	OM 470.913	D	341	2658 L	07.2011 →	OM 473.900	D	567
2646 L	07.2015 →	OM 470.913	D	341	2658 L	07.2011 →	OM 473.900	D	567
2646 L	07.2015 →	OM 470.913	D	341	2658 L	07.2011 →	OM 473.907	D	568
2646 LS	01.2012 →	OM 460.953	D	465	2658 L	07.2011 →	OM 473.907	D	568
2646 LS	01.2012 →	OM 471.900	D	556	2658 L	07.2011 →	OM 473.907	D	568
2646 LS	01.2012 →	OM 471.909	D	556	2658 L	07.2011 →	OM 473.909	D	569
2646 LS	01.2012 →	OM 471.909	D	556	2658 L	07.2011 →	OM 473.909	D	569
2646 LS	07.2015 →	OM 470.910	D	341	2658 L	07.2011 →	OM 473.909	D	569
2646 LS	07.2015 →	OM 470.910	D	341	2658 L	05.2013 →	OM 473.900	D	567
2646 LS	07.2015 →	OM 470.910	D	341	2658 L	05.2013 →	OM 473.907	D	568
2646 LS	07.2015 →	OM 470.910	D	341	2658 L	05.2013 →	OM 473.907	D	568
2646 LS	07.2015 →	OM 470.910	D	341	2658 L	05.2013 →	OM 473.909	D	569

M

			Pos				Pos
2658 LS	07.2011 →	OM 473.900	D 567	3340 LS	07.2011 →	OM 470.906	D 341
2658 LS	07.2011 →	OM 473.900	D 567	3340 LS	05.2013 →	OM 470.906	D 341
2658 LS	07.2011 →	OM 473.907	D 568	3340 LS	05.2013 →	OM 470.910	D 341
2658 LS	07.2011 →	OM 473.907	D 568	3340 LS	05.2013 →	OM 470.913	D 341
2658 LS	07.2011 →	OM 473.909	D 569	3342 L	07.2011 →	OM 471.900	D 556
2658 LS	07.2011 →	OM 473.909	D 569	3342 L	07.2011 →	OM 471.909	D 556
2658 LS	05.2013 →	OM 473.900	D 567	3342 L	05.2013 →	OM 471.900	D 556
2658 LS	05.2013 →	OM 473.907	D 568	3342 L	05.2013 →	OM 471.909	D 556
2658 LS	05.2013 →	OM 473.909	D 569	3342 L	05.2013 →	OM 471.922	D 557
2663 L	07.2011 →	OM 473.900	D 567	3342 L	05.2013 →	OM 471.926	D 558
2663 L	07.2011 →	OM 473.900	D 567	3342 LS	07.2011 →	OM 471.900	D 556
2663 L	07.2011 →	OM 473.907	D 568	3342 LS	07.2011 →	OM 471.909	D 556
2663 L	07.2011 →	OM 473.907	D 568	3342 LS	05.2013 →	OM 471.900	D 556
2663 L	07.2011 →	OM 473.909	D 569	3342 LS	05.2013 →	OM 471.909	D 556
2663 L	07.2011 →	OM 473.909	D 569	3342 LS	05.2013 →	OM 471.922	D 557
2663 L	05.2013 →	OM 473.900	D 567	3342 LS	05.2013 →	OM 471.926	D 558
2663 L	05.2013 →	OM 473.907	D 568	3343 L	07.2011 →	OM 470.906	D 341
2663 L	05.2013 →	OM 473.909	D 569	3343 L	05.2013 →	OM 470.906	D 341
2663 LS	07.2011 →	OM 473.900	D 567	3343 L	05.2013 →	OM 470.910	D 341
2663 LS	07.2011 →	OM 473.900	D 567	3343 L	05.2013 →	OM 470.913	D 341
2663 LS	07.2011 →	OM 473.907	D 568	3343 LS	07.2011 →	OM 470.906	D 341
2663 LS	07.2011 →	OM 473.907	D 568	3343 LS	05.2013 →	OM 470.906	D 341
2663 LS	07.2011 →	OM 473.909	D 569	3343 LS	05.2013 →	OM 470.910	D 341
2663 LS	07.2011 →	OM 473.909	D 569	3343 LS	05.2013 →	OM 470.913	D 341
2663 LS	05.2013 →	OM 473.900	D 567	3345 L	07.2011 →	OM 471.900	D 556
2663 LS	05.2013 →	OM 473.907	D 568	3345 L	07.2011 →	OM 471.909	D 556
2663 LS	05.2013 →	OM 473.909	D 569	3345 L	05.2013 →	OM 471.900	D 556
3232 L	07.2011 →	OM 470.906	D 341	3345 L	05.2013 →	OM 471.909	D 556
3232 L	07.2011 →	OM 470.913	D 341	3345 L	05.2013 →	OM 471.922	D 557
3232 L	07.2011 →	OM 936.916	D 316	3345 L	05.2013 →	OM 471.926	D 558
3235 L	07.2011 →	OM 936.916	D 316	3345 LS	07.2011 →	OM 471.900	D 556
3236 L	07.2011 →	OM 470.906	D 341	3345 LS	07.2011 →	OM 471.909	D 556
3236 L	07.2011 →	OM 470.913	D 341	3345 LS	05.2013 →	OM 471.900	D 556
3240 L	07.2011 →	OM 470.906	D 341	3345 LS	05.2013 →	OM 471.909	D 556
3240 L	07.2011 →	OM 470.913	D 341	3345 LS	05.2013 →	OM 471.922	D 557
3242 L	07.2011 →	OM 471.900	D 556	3345 LS	05.2013 →	OM 471.926	D 558
3242 L	07.2011 →	OM 471.909	D 556	3346 L	07.2015 →	OM 470.910	D 341
3242 L	07.2011 →	OM 471.926	D 558	3346 L	07.2015 →	OM 470.910	D 341
3243 L	07.2011 →	OM 470.906	D 341	3346 L	07.2015 →	OM 470.913	D 341
3243 L	07.2011 →	OM 470.913	D 341	3346 L	07.2015 →	OM 470.913	D 341
3245 L	07.2011 →	OM 471.900	D 556	3346 LS	07.2015 →	OM 470.910	D 341
3245 L	07.2011 →	OM 471.909	D 556	3346 LS	07.2015 →	OM 470.910	D 341
3245 L	07.2011 →	OM 471.926	D 558	3346 LS	07.2015 →	OM 470.913	D 341
3246 L	07.2015 →	OM 470.913	D 341	3346 LS	07.2015 →	OM 470.913	D 341
3248 L	07.2011 →	OM 471.900	D 556	3348 L	07.2011 →	OM 471.900	D 556
3251 L	07.2011 →	OM 471.900	D 556	3348 L	05.2013 →	OM 471.900	D 556
3251 L	07.2011 →	OM 471.909	D 556	3348 L	05.2013 →	OM 471.922	D 557
3251 L	07.2011 →	OM 471.926	D 558	3348 L	05.2013 →	OM 471.926	D 558
3253 L	07.2015 →	OM 471.926	D 558	3348 LS	07.2011 →	OM 471.900	D 556
3333 L	07.2011 →	OM 470.906	D 341	3348 LS	05.2013 →	OM 471.900	D 556
3333 L	05.2013 →	OM 470.906	D 341	3348 LS	05.2013 →	OM 471.922	D 557
3333 L	05.2013 →	OM 470.910	D 341	3348 LS	05.2013 →	OM 471.926	D 558
3333 L	05.2013 →	OM 470.913	D 341	3351 L	07.2011 →	OM 471.900	D 556
3333 LS	07.2011 →	OM 470.906	D 341	3351 L	07.2011 →	OM 471.909	D 556
3333 LS	05.2013 →	OM 470.906	D 341	3351 L	05.2013 →	OM 471.900	D 556
3333 LS	05.2013 →	OM 470.910	D 341	3351 L	05.2013 →	OM 471.909	D 556
3333 LS	05.2013 →	OM 470.913	D 341	3351 L	05.2013 →	OM 471.922	D 557
3336 L	07.2011 →	OM 470.906	D 341	3351 L	05.2013 →	OM 471.926	D 558
3336 L	05.2013 →	OM 470.906	D 341	3351 LS	07.2011 →	OM 471.900	D 556
3336 L	05.2013 →	OM 470.910	D 341	3351 LS	07.2011 →	OM 471.909	D 556
3336 L	05.2013 →	OM 470.913	D 341	3351 LS	05.2013 →	OM 471.900	D 556
3336 LS	07.2011 →	OM 470.906	D 341	3351 LS	05.2013 →	OM 471.909	D 556
3336 LS	05.2013 →	OM 470.906	D 341	3351 LS	05.2013 →	OM 471.922	D 557
3336 LS	05.2013 →	OM 470.910	D 341	3351 LS	05.2013 →	OM 471.926	D 558
3336 LS	05.2013 →	OM 470.913	D 341	3352 L	07.2011 →	OM 473.900	D 567
3340 L	07.2011 →	OM 470.906	D 341	3352 L	07.2011 →	OM 473.907	D 568
3340 L	05.2013 →	OM 470.906	D 341	3352 L	07.2011 →	OM 473.909	D 569
3340 L	05.2013 →	OM 470.910	D 341	3352 L	05.2013 →	OM 473.900	D 567
3340 L	05.2013 →	OM 470.913	D 341	3352 L	05.2013 →	OM 473.907	D 568



				Pos					Pos
3352 L	05.2013 →	OM 473.909	D	569	LAK 1313	06.1986 → 12.1997	OM 352.912	D	129
3352 LS	07.2011 →	OM 473.900	D	567	LAK 1418	01.1989 → 12.1993	OM 376.962	D	186
3352 LS	07.2011 →	OM 473.907	D	568	LG 1213	01.1971 →	OM 352.912	D	129
3352 LS	07.2011 →	OM 473.909	D	569	LG 1819	08.1991 →	OM 345.946	D	363
3352 LS	05.2013 →	OM 473.900	D	567	LK 1113	01.1974 → 04.1987	OM 352.912	D	129
3352 LS	05.2013 →	OM 473.907	D	568	LK 1113	06.1987 → 06.1997	OM 352.912	D	129
3352 LS	05.2013 →	OM 473.909	D	569	LK 1313	01.1967 → 02.2001	OM 352.912	D	129
3352 SLT	12.2013 →	OM 473.900	D	567	LK 1316	01.1975 → 12.1987	OM 352.949	D	133
3353 L	07.2015 →	OM 471.922	D	557	LK 1513	10.1969 → 02.2001	OM 352.915	D	129
3353 L	07.2015 →	OM 471.922	D	557	LK 1516	01.1974 → 01.1999	OM 352.916	D	133
3353 L	07.2015 →	OM 471.926	D	558	LK 1517	06.1986 → 05.1989	OM 353.909	D	133
3353 L	07.2015 →	OM 471.926	D	558	LK 1519	01.1973 → 04.1987	OM 345.946	D	363
3353 LS	07.2015 →	OM 471.922	D	557	LK 2213	01.1972 → 07.1997	OM 352.912	D	129
3353 LS	07.2015 →	OM 471.922	D	557	LK 2216	01.1976 → 12.1987	OM 352.916	D	133
3353 LS	07.2015 →	OM 471.926	D	558	LK 2217	11.1985 → 11.1995	OM 353.909	D	133
3353 LS	07.2015 →	OM 471.926	D	558	LK 2219	01.1973 → 12.1980	OM 345.900	D	363
3358 L	07.2011 →	OM 473.900	D	567	LK 2220	05.1987 → 05.1997	OM 345.973	D	368
3358 L	07.2011 →	OM 473.907	D	568	LK 2318	05.1990 → 05.2000	OM 376.946	D	186
3358 L	07.2011 →	OM 473.909	D	569	LK 2318	05.1990 → 05.2000	OM 376.955	D	186
3358 L	05.2013 →	OM 473.900	D	567	LK 2325	05.1990 → 05.2005	OM 489.961	D	417
3358 L	05.2013 →	OM 473.907	D	568	LPO 1113	06.1974 → 06.1994	OM 352.901	D	129
3358 L	05.2013 →	OM 473.909	D	569	LS 1519	01.1973 → 04.1987	OM 345.946	D	363
3358 LS	07.2011 →	OM 473.900	D	567	LS 2635	09.1992 → 09.2002	OM 476.983	D	401
3358 LS	07.2011 →	OM 473.907	D	568	LS 2638	08.1998 → 12.2005	OM 457.920	D	453
3358 LS	07.2011 →	OM 473.909	D	569	<b>ALLEGRO</b>				
3358 LS	05.2013 →	OM 473.900	D	567	Allegro	01.2002 → 12.2013	OM 906.947	D	241
3358 LS	05.2013 →	OM 473.907	D	568	<b>ALLIADO</b>				
3358 LS	05.2013 →	OM 473.909	D	569	Alliado	01.2010 →	OM 926.950	D	282
3358 SLT	12.2013 →	OM 473.900	D	567	<b>ANTOS</b>				
3363 L	07.2011 →	OM 473.900	D	567	1824 L	07.2012 →	OM 936.912	D	316
3363 L	07.2011 →	OM 473.907	D	568	1824 L	05.2013 →	OM 936.912	D	316
3363 L	07.2011 →	OM 473.909	D	569	1824 LS	07.2012 →	OM 936.912	D	316
3363 L	05.2013 →	OM 473.900	D	567	1824 LS	05.2013 →	OM 936.912	D	316
3363 L	05.2013 →	OM 473.907	D	568	1827 L	07.2012 →	OM 936.912	D	316
3363 L	05.2013 →	OM 473.909	D	569	1827 L	05.2013 →	OM 936.912	D	316
3363 LS	07.2011 →	OM 473.900	D	567	1827 LS	07.2012 →	OM 936.912	D	316
3363 LS	07.2011 →	OM 473.907	D	568	1827 LS	05.2013 →	OM 936.912	D	316
3363 LS	07.2011 →	OM 473.909	D	569	1830 L	07.2012 →	OM 936.912	D	316
3363 LS	05.2013 →	OM 473.900	D	567	1830 L	05.2013 →	OM 936.912	D	316
3363 LS	05.2013 →	OM 473.907	D	568	1830 LS	07.2012 →	OM 936.912	D	316
3363 LS	05.2013 →	OM 473.909	D	569	1830 LS	05.2013 →	OM 936.912	D	316
3363 SLT	12.2013 →	OM 473.900	D	567	1832 L	07.2012 →	OM 936.916	D	316
4152 LS	01.2014 →	OM 473.900	D	567	1832 L	05.2013 →	OM 936.916	D	316
4158 SLT	12.2013 →	OM 473.900	D	567	1832 LS	07.2012 →	OM 936.916	D	316
4160 S	01.2014 →	OM 542.956	D	510	1832 LS	05.2013 →	OM 936.916	D	316
4160 S	01.2014 →	OM 542.957	D	510	1833 L	07.2012 →	OM 470.906	D	341
4160 S	01.2014 →	OM 942.990	D	519	1833 L	05.2013 →	OM 470.906	D	341
4163 SLT	12.2013 →	OM 473.900	D	567	1833 L	05.2013 →	OM 470.910	D	341
4844	07.2011 →	OM 541.993	D	537	1833 L	05.2013 →	OM 470.913	D	341
<b>AGL (RoundNose)</b>					1833 LS	07.2012 →	OM 470.906	D	341
L 1113	01.1967 → 06.1997	OM 352.912	D	129	1833 LS	05.2013 →	OM 470.906	D	341
L 1113	06.1987 → 06.1997	OM 352.912	D	129	1833 LS	05.2013 →	OM 470.910	D	341
L 1117	06.1987 → 06.1997	OM 353.909	D	133	1833 LS	05.2013 →	OM 470.913	D	341
L 1313	07.1987 → 07.1997	OM 352.912	D	129	1835 L	07.2012 →	OM 936.916	D	316
L 1316	03.1974 → 03.1998	OM 352.949	D	133	1835 L	05.2013 →	OM 936.916	D	316
L 1513	07.1987 → 02.2001	OM 352.915	D	129	1835 LS	07.2012 →	OM 936.916	D	316
L 1516	01.1974 → 01.1999	OM 352.916	D	133	1835 LS	05.2013 →	OM 936.916	D	316
L 1517	06.1986 → 05.1989	OM 353.909	D	133	1836 L	07.2012 →	OM 470.906	D	341
L 1518	06.1987 → 05.1997	OM 353.909	D	133	1836 L	05.2013 →	OM 470.906	D	341
L 1519	01.1973 → 12.1987	OM 345.946	D	363	1836 L	05.2013 →	OM 470.910	D	341
L 2013	01.1970 → 06.1997	OM 352.912	D	129	1836 L	05.2013 →	OM 470.913	D	341
L 2017	01.1990 → 12.1991	OM 353.909	D	133	1836 LS	07.2012 →	OM 470.906	D	341
L 2213	01.1970 → 03.1999	OM 352.912	D	129	1836 LS	05.2013 →	OM 470.906	D	341
L 2216	01.1974 → 03.1999	OM 352.968	D	133	1836 LS	05.2013 →	OM 470.910	D	341
L 2318	04.1989 → 07.1999	OM 376.946	D	186	1836 LS	05.2013 →	OM 470.913	D	341
L 2318	04.1989 → 07.1999	OM 376.955	D	186	1840 L	07.2012 →	OM 470.906	D	341
L 709	03.1984 → 12.1993	OM 364.950	D	210	1840 L	05.2013 →	OM 470.906	D	341
LA 1313	01.1974 → 04.1987	OM 352.912	D	129	1840 L	05.2013 →	OM 470.910	D	341
LA 1418	01.1989 → 12.1993	OM 376.962	D	186	1840 L	05.2013 →	OM 470.913	D	341

M

				Pos					Pos
1840 LS	07.2012 →	OM 470.906	D	341	1852 LS	05.2013 →	OM 473.907	D	568
1840 LS	05.2013 →	OM 470.906	D	341	1852 LS	05.2013 →	OM 473.909	D	569
1840 LS	05.2013 →	OM 470.910	D	341	1852 LS	05.2013 →	OM 473.915	D	568
1840 LS	05.2013 →	OM 470.913	D	341	1853 L	07.2015 →	OM 471.922	D	557
1842 L	07.2012 →	OM 471.900	D	556	1853 L	07.2015 →	OM 471.922	D	557
1842 L	05.2013 →	OM 471.900	D	556	1853 L	07.2015 →	OM 471.926	D	558
1842 L	05.2013 →	OM 471.909	D	556	1853 L	07.2015 →	OM 471.926	D	558
1842 L	05.2013 →	OM 471.922	D	557	1853 LS	07.2015 →	OM 471.922	D	557
1842 L	05.2013 →	OM 471.926	D	558	1853 LS	07.2015 →	OM 471.922	D	557
1842 LS	07.2012 →	OM 471.900	D	556	1853 LS	07.2015 →	OM 471.926	D	558
1842 LS	05.2013 →	OM 471.900	D	556	1853 LS	07.2015 →	OM 471.926	D	558
1842 LS	05.2013 →	OM 471.909	D	556	1858 L	09.2012 →	OM 473.900	D	567
1842 LS	05.2013 →	OM 471.922	D	557	1858 L	09.2012 →	OM 473.907	D	568
1842 LS	05.2013 →	OM 471.926	D	558	1858 L	09.2012 →	OM 473.909	D	569
1843 L	07.2012 →	OM 470.906	D	341	1858 L	05.2013 →	OM 473.900	D	567
1843 L	05.2013 →	OM 470.906	D	341	1858 L	05.2013 →	OM 473.907	D	568
1843 L	05.2013 →	OM 470.910	D	341	1858 L	05.2013 →	OM 473.909	D	569
1843 L	05.2013 →	OM 470.913	D	341	1858 LS	09.2012 →	OM 473.900	D	567
1843 LS	07.2012 →	OM 470.906	D	341	1858 LS	09.2012 →	OM 473.907	D	568
1843 LS	05.2013 →	OM 470.906	D	341	1858 LS	09.2012 →	OM 473.909	D	569
1843 LS	05.2013 →	OM 470.910	D	341	1858 LS	09.2012 →	OM 473.915	D	568
1843 LS	05.2013 →	OM 470.913	D	341	1858 LS	05.2013 →	OM 473.900	D	567
1845 L	07.2012 →	OM 471.900	D	556	1858 LS	05.2013 →	OM 473.907	D	568
1845 L	05.2013 →	OM 471.900	D	556	1858 LS	05.2013 →	OM 473.909	D	569
1845 L	05.2013 →	OM 471.909	D	556	1858 LS	05.2013 →	OM 473.915	D	568
1845 L	05.2013 →	OM 471.922	D	557	1863 L	09.2012 →	OM 473.900	D	567
1845 L	05.2013 →	OM 471.926	D	558	1863 L	09.2012 →	OM 473.907	D	568
1845 LS	07.2012 →	OM 471.900	D	556	1863 L	09.2012 →	OM 473.909	D	569
1845 LS	05.2013 →	OM 471.900	D	556	1863 L	05.2013 →	OM 473.900	D	567
1845 LS	05.2013 →	OM 471.909	D	556	1863 L	05.2013 →	OM 473.907	D	568
1845 LS	05.2013 →	OM 471.922	D	557	1863 L	05.2013 →	OM 473.909	D	569
1845 LS	05.2013 →	OM 471.926	D	558	1863 LS	09.2012 →	OM 473.900	D	567
1846 L	07.2015 →	OM 470.910	D	341	1863 LS	09.2012 →	OM 473.907	D	568
1846 L	07.2015 →	OM 470.910	D	341	1863 LS	09.2012 →	OM 473.909	D	569
1846 L	07.2015 →	OM 470.913	D	341	1863 LS	09.2012 →	OM 473.915	D	568
1846 L	07.2015 →	OM 470.913	D	341	1863 LS	05.2013 →	OM 473.900	D	567
1846 LS	07.2015 →	OM 470.910	D	341	1863 LS	05.2013 →	OM 473.907	D	568
1846 LS	07.2015 →	OM 470.910	D	341	1863 LS	05.2013 →	OM 473.909	D	569
1846 LS	07.2015 →	OM 470.913	D	341	1863 LS	05.2013 →	OM 473.915	D	568
1846 LS	07.2015 →	OM 470.913	D	341	2024 L	07.2012 →	OM 936.912	D	316
1848 L	07.2012 →	OM 471.900	D	556	2024 L	05.2013 →	OM 936.912	D	316
1848 L	05.2013 →	OM 471.900	D	556	2024 LS	07.2012 →	OM 936.912	D	316
1848 L	05.2013 →	OM 471.922	D	557	2024 LS	05.2013 →	OM 936.912	D	316
1848 L	05.2013 →	OM 471.926	D	558	2027 L	07.2012 →	OM 936.912	D	316
1848 LS	07.2012 →	OM 471.900	D	556	2027 L	05.2013 →	OM 936.912	D	316
1848 LS	05.2013 →	OM 471.900	D	556	2027 LS	07.2012 →	OM 936.912	D	316
1848 LS	05.2013 →	OM 471.922	D	557	2027 LS	05.2013 →	OM 936.912	D	316
1848 LS	05.2013 →	OM 471.926	D	558	2030 L	07.2012 →	OM 936.912	D	316
1851 L	07.2012 →	OM 471.900	D	556	2030 L	05.2013 →	OM 936.912	D	316
1851 L	05.2013 →	OM 471.900	D	556	2030 LS	07.2012 →	OM 936.912	D	316
1851 L	05.2013 →	OM 471.909	D	556	2030 LS	05.2013 →	OM 936.912	D	316
1851 L	05.2013 →	OM 471.922	D	557	2032 L	07.2012 →	OM 936.916	D	316
1851 L	05.2013 →	OM 471.926	D	558	2032 L	05.2013 →	OM 936.916	D	316
1851 LS	07.2012 →	OM 471.900	D	556	2032 LS	07.2012 →	OM 936.916	D	316
1851 LS	05.2013 →	OM 471.900	D	556	2032 LS	05.2013 →	OM 936.916	D	316
1851 LS	05.2013 →	OM 471.909	D	556	2033 L	07.2012 →	OM 470.906	D	341
1851 LS	05.2013 →	OM 471.922	D	557	2033 L	05.2013 →	OM 470.906	D	341
1851 LS	05.2013 →	OM 471.926	D	558	2033 L	05.2013 →	OM 470.910	D	341
1852 L	09.2012 →	OM 473.900	D	567	2033 L	05.2013 →	OM 470.913	D	341
1852 L	09.2012 →	OM 473.907	D	568	2033 LS	07.2012 →	OM 470.906	D	341
1852 L	09.2012 →	OM 473.909	D	569	2033 LS	05.2013 →	OM 470.906	D	341
1852 L	05.2013 →	OM 473.900	D	567	2033 LS	05.2013 →	OM 470.910	D	341
1852 L	05.2013 →	OM 473.907	D	568	2033 LS	05.2013 →	OM 470.913	D	341
1852 L	05.2013 →	OM 473.909	D	569	2035 L	07.2012 →	OM 936.916	D	316
1852 LS	09.2012 →	OM 473.900	D	567	2035 L	05.2013 →	OM 936.916	D	316
1852 LS	09.2012 →	OM 473.907	D	568	2035 LS	07.2012 →	OM 936.916	D	316
1852 LS	09.2012 →	OM 473.909	D	569	2035 LS	05.2013 →	OM 936.916	D	316
1852 LS	09.2012 →	OM 473.915	D	568	2036 L	07.2012 →	OM 470.906	D	341
1852 LS	05.2013 →	OM 473.900	D	567	2036 L	05.2013 →	OM 470.906	D	341



				Pos					Pos
2036 L	05.2013 →	OM 470.910	D	341	2052 L	09.2012 →	OM 473.907	D	568
2036 L	05.2013 →	OM 470.913	D	341	2052 L	09.2012 →	OM 473.909	D	569
2036 LS	07.2012 →	OM 470.906	D	341	2052 L	05.2013 →	OM 473.900	D	567
2036 LS	05.2013 →	OM 470.906	D	341	2052 L	05.2013 →	OM 473.907	D	568
2036 LS	05.2013 →	OM 470.910	D	341	2052 L	05.2013 →	OM 473.909	D	569
2036 LS	05.2013 →	OM 470.913	D	341	2052 LS	09.2012 →	OM 473.900	D	567
2040 L	07.2012 →	OM 470.906	D	341	2052 LS	09.2012 →	OM 473.907	D	568
2040 L	05.2013 →	OM 470.906	D	341	2052 LS	09.2012 →	OM 473.909	D	569
2040 L	05.2013 →	OM 470.910	D	341	2052 LS	05.2013 →	OM 473.900	D	567
2040 L	05.2013 →	OM 470.913	D	341	2052 LS	05.2013 →	OM 473.907	D	568
2040 LS	07.2012 →	OM 470.906	D	341	2052 LS	05.2013 →	OM 473.909	D	569
2040 LS	05.2013 →	OM 470.906	D	341	2053 L	07.2015 →	OM 471.922	D	557
2040 LS	05.2013 →	OM 470.910	D	341	2053 L	07.2015 →	OM 471.922	D	557
2040 LS	05.2013 →	OM 470.913	D	341	2053 L	07.2015 →	OM 471.926	D	558
2042 L	07.2012 →	OM 471.900	D	556	2053 L	07.2015 →	OM 471.926	D	558
2042 L	05.2013 →	OM 471.900	D	556	2053 LS	07.2015 →	OM 471.922	D	557
2042 L	05.2013 →	OM 471.909	D	556	2053 LS	07.2015 →	OM 471.922	D	557
2042 L	05.2013 →	OM 471.922	D	557	2053 LS	07.2015 →	OM 471.926	D	558
2042 L	05.2013 →	OM 471.926	D	558	2053 LS	07.2015 →	OM 471.926	D	558
2042 LS	07.2012 →	OM 471.900	D	556	2058 L	09.2012 →	OM 473.900	D	567
2042 LS	05.2013 →	OM 471.900	D	556	2058 L	09.2012 →	OM 473.907	D	568
2042 LS	05.2013 →	OM 471.909	D	556	2058 L	09.2012 →	OM 473.909	D	569
2042 LS	05.2013 →	OM 471.922	D	557	2058 L	05.2013 →	OM 473.900	D	567
2042 LS	05.2013 →	OM 471.926	D	558	2058 L	05.2013 →	OM 473.907	D	568
2043 L	07.2012 →	OM 470.906	D	341	2058 L	05.2013 →	OM 473.909	D	569
2043 L	05.2013 →	OM 470.906	D	341	2058 LS	09.2012 →	OM 473.900	D	567
2043 L	05.2013 →	OM 470.910	D	341	2058 LS	09.2012 →	OM 473.907	D	568
2043 L	05.2013 →	OM 470.913	D	341	2058 LS	09.2012 →	OM 473.909	D	569
2043 LS	07.2012 →	OM 470.906	D	341	2058 LS	05.2013 →	OM 473.900	D	567
2043 LS	05.2013 →	OM 470.906	D	341	2058 LS	05.2013 →	OM 473.907	D	568
2043 LS	05.2013 →	OM 470.910	D	341	2058 LS	05.2013 →	OM 473.909	D	569
2043 LS	05.2013 →	OM 470.913	D	341	2063 L	09.2012 →	OM 473.900	D	567
2045 L	07.2012 →	OM 471.900	D	556	2063 L	09.2012 →	OM 473.907	D	568
2045 L	05.2013 →	OM 471.900	D	556	2063 L	09.2012 →	OM 473.909	D	569
2045 L	05.2013 →	OM 471.909	D	556	2063 L	05.2013 →	OM 473.900	D	567
2045 L	05.2013 →	OM 471.922	D	557	2063 L	05.2013 →	OM 473.907	D	568
2045 L	05.2013 →	OM 471.926	D	558	2063 L	05.2013 →	OM 473.909	D	569
2045 LS	07.2012 →	OM 471.900	D	556	2063 LS	09.2012 →	OM 473.900	D	567
2045 LS	05.2013 →	OM 471.900	D	556	2063 LS	09.2012 →	OM 473.907	D	568
2045 LS	05.2013 →	OM 471.909	D	556	2063 LS	09.2012 →	OM 473.909	D	569
2045 LS	05.2013 →	OM 471.922	D	557	2063 LS	05.2013 →	OM 473.900	D	567
2045 LS	05.2013 →	OM 471.926	D	558	2063 LS	05.2013 →	OM 473.907	D	568
2046 L	07.2015 →	OM 470.910	D	341	2063 LS	05.2013 →	OM 473.909	D	569
2046 L	07.2015 →	OM 470.910	D	341	2424 LS	09.2012 →	OM 936.912	D	316
2046 L	07.2015 →	OM 470.913	D	341	2427 LS	07.2012 →	OM 936.912	D	316
2046 L	07.2015 →	OM 470.913	D	341	2430 LS	07.2012 →	OM 936.912	D	316
2046 LS	07.2015 →	OM 470.910	D	341	2432 LS	07.2012 →	OM 936.916	D	316
2046 LS	07.2015 →	OM 470.910	D	341	2433 LS	07.2012 →	OM 470.906	D	341
2046 LS	07.2015 →	OM 470.913	D	341	2435 LS	07.2012 →	OM 936.916	D	316
2046 LS	07.2015 →	OM 470.913	D	341	2436 LS	07.2012 →	OM 470.906	D	341
2048 L	07.2012 →	OM 471.900	D	556	2440 LS	07.2012 →	OM 470.906	D	341
2048 L	05.2013 →	OM 471.900	D	556	2442 LS	07.2012 →	OM 471.900	D	556
2048 L	05.2013 →	OM 471.922	D	557	2443 LS	07.2012 →	OM 470.906	D	341
2048 L	05.2013 →	OM 471.926	D	558	2445 LS	07.2012 →	OM 471.900	D	556
2048 LS	07.2012 →	OM 471.900	D	556	2446 LS	07.2015 →	OM 470.910	D	341
2048 LS	05.2013 →	OM 471.900	D	556	2446 LS	07.2015 →	OM 470.913	D	341
2048 LS	05.2013 →	OM 471.922	D	557	2448 LS	07.2012 →	OM 471.900	D	556
2048 LS	05.2013 →	OM 471.926	D	558	2451 LS	07.2012 →	OM 471.900	D	556
2051 L	07.2012 →	OM 471.900	D	556	2452 LS	09.2012 →	OM 473.900	D	567
2051 L	05.2013 →	OM 471.900	D	556	2452 LS	09.2012 →	OM 473.907	D	568
2051 L	05.2013 →	OM 471.909	D	556	2452 LS	09.2012 →	OM 473.909	D	569
2051 L	05.2013 →	OM 471.922	D	557	2453 LS	07.2015 →	OM 471.922	D	557
2051 L	05.2013 →	OM 471.926	D	558	2453 LS	07.2015 →	OM 471.926	D	558
2051 LS	07.2012 →	OM 471.900	D	556	2458 LS	09.2012 →	OM 473.900	D	567
2051 LS	05.2013 →	OM 471.900	D	556	2458 LS	09.2012 →	OM 473.907	D	568
2051 LS	05.2013 →	OM 471.909	D	556	2458 LS	09.2012 →	OM 473.909	D	569
2051 LS	05.2013 →	OM 471.922	D	557	2463 LS	09.2012 →	OM 473.900	D	567
2051 LS	05.2013 →	OM 471.926	D	558	2463 LS	09.2012 →	OM 473.907	D	568
2052 L	09.2012 →	OM 473.900	D	567	2463 LS	09.2012 →	OM 473.909	D	569

M









				Pos					Pos
2642 LS	05.2013 →	OM 471.922	D	557	2652 L	05.2013 →	OM 473.907	D	568
2642 LS	05.2013 →	OM 471.926	D	558	2652 L	05.2013 →	OM 473.909	D	569
2643 L	07.2012 →	OM 470.906	D	341	2652 LS	09.2012 →	OM 473.900	D	567
2643 L	07.2012 →	OM 470.906	D	341	2652 LS	09.2012 →	OM 473.900	D	567
2643 L	07.2012 →	OM 470.906	D	341	2652 LS	09.2012 →	OM 473.907	D	568
2643 L	05.2013 →	OM 470.906	D	341	2652 LS	09.2012 →	OM 473.907	D	568
2643 L	05.2013 →	OM 470.910	D	341	2652 LS	09.2012 →	OM 473.909	D	569
2643 L	05.2013 →	OM 470.913	D	341	2652 LS	09.2012 →	OM 473.909	D	569
2643 LS	07.2012 →	OM 470.906	D	341	2652 LS	05.2013 →	OM 473.900	D	567
2643 LS	07.2012 →	OM 470.906	D	341	2652 LS	05.2013 →	OM 473.907	D	568
2643 LS	05.2013 →	OM 470.906	D	341	2652 LS	05.2013 →	OM 473.909	D	569
2643 LS	05.2013 →	OM 470.910	D	341	2653 L	07.2015 →	OM 471.922	D	557
2643 LS	05.2013 →	OM 470.913	D	341	2653 L	07.2015 →	OM 471.922	D	557
2645	07.2012 →	OM 471.900	D	556	2653 L	07.2015 →	OM 471.922	D	557
2645 L	07.2012 →	OM 471.900	D	556	2653 L	07.2015 →	OM 471.926	D	558
2645 L	07.2012 →	OM 471.900	D	556	2653 L	07.2015 →	OM 471.926	D	558
2645 L	05.2013 →	OM 471.900	D	556	2653 L	07.2015 →	OM 471.926	D	558
2645 L	05.2013 →	OM 471.909	D	556	2653 LS	07.2015 →	OM 471.922	D	557
2645 L	05.2013 →	OM 471.922	D	557	2653 LS	07.2015 →	OM 471.922	D	557
2645 L	05.2013 →	OM 471.926	D	558	2653 LS	07.2015 →	OM 471.922	D	557
2645 LS	07.2012 →	OM 471.900	D	556	2653 LS	07.2015 →	OM 471.926	D	558
2645 LS	07.2012 →	OM 471.900	D	556	2653 LS	07.2015 →	OM 471.926	D	558
2645 LS	05.2013 →	OM 471.900	D	556	2653 LS	07.2015 →	OM 471.926	D	558
2645 LS	05.2013 →	OM 471.909	D	556	2658 L	09.2012 →	OM 473.900	D	567
2645 LS	05.2013 →	OM 471.922	D	557	2658 L	09.2012 →	OM 473.900	D	567
2645 LS	05.2013 →	OM 471.926	D	558	2658 L	09.2012 →	OM 473.907	D	568
2646 L	07.2015 →	OM 470.910	D	341	2658 L	09.2012 →	OM 473.907	D	568
2646 L	07.2015 →	OM 470.910	D	341	2658 L	09.2012 →	OM 473.909	D	569
2646 L	07.2015 →	OM 470.910	D	341	2658 L	09.2012 →	OM 473.909	D	569
2646 L	07.2015 →	OM 470.913	D	341	2658 L	05.2013 →	OM 473.900	D	567
2646 L	07.2015 →	OM 470.913	D	341	2658 L	05.2013 →	OM 473.907	D	568
2646 L	07.2015 →	OM 470.913	D	341	2658 L	05.2013 →	OM 473.909	D	569
2646 LS	07.2015 →	OM 470.910	D	341	2658 LS	09.2012 →	OM 473.900	D	567
2646 LS	07.2015 →	OM 470.910	D	341	2658 LS	09.2012 →	OM 473.900	D	567
2646 LS	07.2015 →	OM 470.910	D	341	2658 LS	09.2012 →	OM 473.907	D	568
2646 LS	07.2015 →	OM 470.913	D	341	2658 LS	09.2012 →	OM 473.907	D	568
2646 LS	07.2015 →	OM 470.913	D	341	2658 LS	09.2012 →	OM 473.909	D	569
2646 LS	07.2015 →	OM 470.913	D	341	2658 LS	09.2012 →	OM 473.909	D	569
2648 L	07.2012 →	OM 471.900	D	556	2658 LS	05.2013 →	OM 473.900	D	567
2648 L	07.2012 →	OM 471.900	D	556	2658 LS	05.2013 →	OM 473.907	D	568
2648 L	07.2012 →	OM 471.900	D	556	2658 LS	05.2013 →	OM 473.909	D	569
2648 L	05.2013 →	OM 471.900	D	556	2663 L	09.2012 →	OM 473.900	D	567
2648 L	05.2013 →	OM 471.922	D	557	2663 L	09.2012 →	OM 473.900	D	567
2648 L	05.2013 →	OM 471.926	D	558	2663 L	09.2012 →	OM 473.907	D	568
2648 LS	07.2012 →	OM 471.900	D	556	2663 L	09.2012 →	OM 473.907	D	568
2648 LS	07.2012 →	OM 471.900	D	556	2663 L	09.2012 →	OM 473.909	D	569
2648 LS	07.2012 →	OM 471.900	D	556	2663 L	09.2012 →	OM 473.909	D	569
2648 LS	05.2013 →	OM 471.900	D	556	2663 L	05.2013 →	OM 473.900	D	567
2648 LS	05.2013 →	OM 471.922	D	557	2663 L	05.2013 →	OM 473.907	D	568
2648 LS	05.2013 →	OM 471.926	D	558	2663 L	05.2013 →	OM 473.909	D	569
2651	07.2012 →	OM 471.900	D	556	2663 L	05.2013 →	OM 473.909	D	569
2651 L	07.2012 →	OM 471.900	D	556	2663 LS	09.2012 →	OM 473.900	D	567
2651 L	07.2012 →	OM 471.900	D	556	2663 LS	09.2012 →	OM 473.900	D	567
2651 L	05.2013 →	OM 471.900	D	556	2663 LS	09.2012 →	OM 473.907	D	568
2651 L	05.2013 →	OM 471.909	D	556	2663 LS	09.2012 →	OM 473.907	D	568
2651 L	05.2013 →	OM 471.922	D	557	2663 LS	09.2012 →	OM 473.909	D	569
2651 L	05.2013 →	OM 471.926	D	558	2663 LS	09.2012 →	OM 473.909	D	569
2651 LS	07.2012 →	OM 471.900	D	556	2663 LS	05.2013 →	OM 473.900	D	567
2651 LS	07.2012 →	OM 471.900	D	556	2663 LS	05.2013 →	OM 473.907	D	568
2651 LS	05.2013 →	OM 471.900	D	556	2663 LS	05.2013 →	OM 473.909	D	569
2651 LS	05.2013 →	OM 471.909	D	556	3232 L	09.2012 →	OM 936.916	D	316
2651 LS	05.2013 →	OM 471.922	D	557	3233 L	09.2012 →	OM 470.906	D	341
2651 LS	05.2013 →	OM 471.926	D	558	3233 L	09.2012 →	OM 470.913	D	341
2652 L	09.2012 →	OM 473.900	D	567	3235 L	09.2012 →	OM 936.916	D	316
2652 L	09.2012 →	OM 473.900	D	567	3236 L	09.2012 →	OM 470.906	D	341
2652 L	09.2012 →	OM 473.907	D	568	3236 L	09.2012 →	OM 470.913	D	341
2652 L	09.2012 →	OM 473.907	D	568	3240 L	09.2012 →	OM 470.906	D	341
2652 L	09.2012 →	OM 473.909	D	569	3240 L	09.2012 →	OM 470.913	D	341
2652 L	09.2012 →	OM 473.909	D	569	3242 L	09.2012 →	OM 471.900	D	556
2652 L	05.2013 →	OM 473.900	D	567	3242 L	09.2012 →	OM 471.909	D	556

M



		Pos			Pos		
3242 L	09.2012 →	OM 471.926 D	<b>558</b>	3346 LS	07.2015 →	OM 470.910 D	<b>341</b>
3243 L	09.2012 →	OM 470.906 D	<b>341</b>	3346 LS	07.2015 →	OM 470.910 D	<b>341</b>
3243 L	09.2012 →	OM 470.913 D	<b>341</b>	3346 LS	07.2015 →	OM 470.913 D	<b>341</b>
3245 L	09.2012 →	OM 471.900 D	<b>556</b>	3346 LS	07.2015 →	OM 470.913 D	<b>341</b>
3245 L	09.2012 →	OM 471.909 D	<b>556</b>	3348 L	07.2012 →	OM 471.900 D	<b>556</b>
3245 L	09.2012 →	OM 471.926 D	<b>558</b>	3348 L	05.2013 →	OM 471.900 D	<b>556</b>
3246 L	07.2015 →	OM 470.913 D	<b>341</b>	3348 L	05.2013 →	OM 471.922 D	<b>557</b>
3248 L	09.2012 →	OM 471.900 D	<b>556</b>	3348 L	05.2013 →	OM 471.926 D	<b>558</b>
3251 L	09.2012 →	OM 471.900 D	<b>556</b>	3348 LS	07.2012 →	OM 471.900 D	<b>556</b>
3251 L	09.2012 →	OM 471.909 D	<b>556</b>	3348 LS	05.2013 →	OM 471.900 D	<b>556</b>
3251 L	09.2012 →	OM 471.926 D	<b>558</b>	3348 LS	05.2013 →	OM 471.922 D	<b>557</b>
3253 L	07.2015 →	OM 471.926 D	<b>558</b>	3348 LS	05.2013 →	OM 471.926 D	<b>558</b>
3333 L	07.2012 →	OM 470.906 D	<b>341</b>	3351 L	07.2012 →	OM 471.900 D	<b>556</b>
3333 L	05.2013 →	OM 470.906 D	<b>341</b>	3351 L	05.2013 →	OM 471.900 D	<b>556</b>
3333 L	05.2013 →	OM 470.910 D	<b>341</b>	3351 L	05.2013 →	OM 471.909 D	<b>556</b>
3333 L	05.2013 →	OM 470.913 D	<b>341</b>	3351 L	05.2013 →	OM 471.922 D	<b>557</b>
3333 LS	07.2012 →	OM 470.906 D	<b>341</b>	3351 L	05.2013 →	OM 471.926 D	<b>558</b>
3333 LS	05.2013 →	OM 470.906 D	<b>341</b>	3351 LS	07.2012 →	OM 471.900 D	<b>556</b>
3333 LS	05.2013 →	OM 470.910 D	<b>341</b>	3351 LS	05.2013 →	OM 471.900 D	<b>556</b>
3333 LS	05.2013 →	OM 470.913 D	<b>341</b>	3351 LS	05.2013 →	OM 471.909 D	<b>556</b>
3336 L	07.2012 →	OM 470.906 D	<b>341</b>	3351 LS	05.2013 →	OM 471.922 D	<b>557</b>
3336 L	05.2013 →	OM 470.906 D	<b>341</b>	3351 LS	05.2013 →	OM 471.926 D	<b>558</b>
3336 L	05.2013 →	OM 470.910 D	<b>341</b>	3352 L	09.2012 →	OM 473.900 D	<b>567</b>
3336 L	05.2013 →	OM 470.913 D	<b>341</b>	3352 L	09.2012 →	OM 473.907 D	<b>568</b>
3336 LS	07.2012 →	OM 470.906 D	<b>341</b>	3352 L	09.2012 →	OM 473.909 D	<b>569</b>
3336 LS	07.2012 →	OM 470.906 D	<b>341</b>	3352 L	05.2013 →	OM 473.900 D	<b>567</b>
3336 LS	05.2013 →	OM 470.906 D	<b>341</b>	3352 L	05.2013 →	OM 473.907 D	<b>568</b>
3336 LS	05.2013 →	OM 470.910 D	<b>341</b>	3352 L	05.2013 →	OM 473.909 D	<b>569</b>
3336 LS	05.2013 →	OM 470.913 D	<b>341</b>	3352 LS	09.2012 →	OM 473.900 D	<b>567</b>
3340 L	07.2012 →	OM 470.906 D	<b>341</b>	3352 LS	09.2012 →	OM 473.907 D	<b>568</b>
3340 L	05.2013 →	OM 470.906 D	<b>341</b>	3352 LS	09.2012 →	OM 473.909 D	<b>569</b>
3340 L	05.2013 →	OM 470.910 D	<b>341</b>	3352 LS	05.2013 →	OM 473.900 D	<b>567</b>
3340 L	05.2013 →	OM 470.913 D	<b>341</b>	3352 LS	05.2013 →	OM 473.907 D	<b>568</b>
3340 LS	07.2012 →	OM 470.906 D	<b>341</b>	3352 LS	05.2013 →	OM 473.909 D	<b>569</b>
3340 LS	05.2013 →	OM 470.906 D	<b>341</b>	3353 L	07.2015 →	OM 471.922 D	<b>557</b>
3340 LS	05.2013 →	OM 470.910 D	<b>341</b>	3353 L	07.2015 →	OM 471.922 D	<b>557</b>
3340 LS	05.2013 →	OM 470.913 D	<b>341</b>	3353 L	07.2015 →	OM 471.926 D	<b>558</b>
3342 L	07.2012 →	OM 471.900 D	<b>556</b>	3353 L	07.2015 →	OM 471.926 D	<b>558</b>
3342 L	05.2013 →	OM 471.900 D	<b>556</b>	3353 LS	07.2015 →	OM 471.922 D	<b>557</b>
3342 L	05.2013 →	OM 471.909 D	<b>556</b>	3353 LS	07.2015 →	OM 471.922 D	<b>557</b>
3342 L	05.2013 →	OM 471.922 D	<b>557</b>	3353 LS	07.2015 →	OM 471.926 D	<b>558</b>
3342 L	05.2013 →	OM 471.926 D	<b>558</b>	3353 LS	07.2015 →	OM 471.926 D	<b>558</b>
3342 LS	07.2012 →	OM 471.900 D	<b>556</b>	3358 L	09.2012 →	OM 473.900 D	<b>567</b>
3342 LS	05.2013 →	OM 471.900 D	<b>556</b>	3358 L	09.2012 →	OM 473.907 D	<b>568</b>
3342 LS	05.2013 →	OM 471.909 D	<b>556</b>	3358 L	09.2012 →	OM 473.909 D	<b>569</b>
3342 LS	05.2013 →	OM 471.922 D	<b>557</b>	3358 L	05.2013 →	OM 473.900 D	<b>567</b>
3342 LS	05.2013 →	OM 471.926 D	<b>558</b>	3358 L	05.2013 →	OM 473.907 D	<b>568</b>
3343 L	07.2012 →	OM 470.906 D	<b>341</b>	3358 L	05.2013 →	OM 473.909 D	<b>569</b>
3343 L	05.2013 →	OM 470.906 D	<b>341</b>	3358 LS	09.2012 →	OM 473.900 D	<b>567</b>
3343 L	05.2013 →	OM 470.910 D	<b>341</b>	3358 LS	09.2012 →	OM 473.907 D	<b>568</b>
3343 L	05.2013 →	OM 470.913 D	<b>341</b>	3358 LS	09.2012 →	OM 473.909 D	<b>569</b>
3343 LS	07.2012 →	OM 470.906 D	<b>341</b>	3358 LS	05.2013 →	OM 473.900 D	<b>567</b>
3343 LS	05.2013 →	OM 470.906 D	<b>341</b>	3358 LS	05.2013 →	OM 473.907 D	<b>568</b>
3343 LS	05.2013 →	OM 470.910 D	<b>341</b>	3358 LS	05.2013 →	OM 473.909 D	<b>569</b>
3343 LS	05.2013 →	OM 470.913 D	<b>341</b>	3363 L	09.2012 →	OM 473.900 D	<b>567</b>
3345 L	07.2012 →	OM 471.900 D	<b>556</b>	3363 L	09.2012 →	OM 473.907 D	<b>568</b>
3345 L	05.2013 →	OM 471.900 D	<b>556</b>	3363 L	09.2012 →	OM 473.909 D	<b>569</b>
3345 L	05.2013 →	OM 471.909 D	<b>556</b>	3363 L	05.2013 →	OM 473.900 D	<b>567</b>
3345 L	05.2013 →	OM 471.922 D	<b>557</b>	3363 L	05.2013 →	OM 473.907 D	<b>568</b>
3345 L	05.2013 →	OM 471.926 D	<b>558</b>	3363 L	05.2013 →	OM 473.909 D	<b>569</b>
3345 LS	07.2012 →	OM 471.900 D	<b>556</b>	3363 LS	09.2012 →	OM 473.900 D	<b>567</b>
3345 LS	05.2013 →	OM 471.900 D	<b>556</b>	3363 LS	09.2012 →	OM 473.907 D	<b>568</b>
3345 LS	05.2013 →	OM 471.909 D	<b>556</b>	3363 LS	09.2012 →	OM 473.909 D	<b>569</b>
3345 LS	05.2013 →	OM 471.922 D	<b>557</b>	3363 LS	05.2013 →	OM 473.900 D	<b>567</b>
3345 LS	05.2013 →	OM 471.926 D	<b>558</b>	3363 LS	05.2013 →	OM 473.907 D	<b>568</b>
3346 L	07.2015 →	OM 470.910 D	<b>341</b>	3363 LS	05.2013 →	OM 473.909 D	<b>569</b>
3346 L	07.2015 →	OM 470.910 D	<b>341</b>	<b>AROCS</b>			
3346 L	07.2015 →	OM 470.913 D	<b>341</b>	1824	01.2013 →	OM 936.912 D	<b>316</b>
3346 L	07.2015 →	OM 470.913 D	<b>341</b>	1824 A	01.2013 →	OM 936.912 D	<b>316</b>

			Pos				Pos		
1824 AK	01.2013 →	OM 936.912	D	316	1836	01.2013 →	OM 470.906	D	341
1824 K	01.2013 →	OM 936.912	D	316	1836 A	01.2013 →	OM 470.908	D	341
1824 L	05.2013 →	OM 936.912	D	316	1836 A	01.2013 →	OM 470.910	D	341
1824 L	05.2013 →	OM 936.912	D	316	1836 A	01.2013 →	OM 470.913	D	341
1824 LK	05.2013 →	OM 936.912	D	316	1836 AK	01.2013 →	OM 470.908	D	341
1824 LK	05.2013 →	OM 936.912	D	316	1836 AK	01.2013 →	OM 470.910	D	341
1824 LS	01.2013 →	OM 936.912	D	316	1836 AK	01.2013 →	OM 470.913	D	341
1824 LS	05.2013 →	OM 936.912	D	316	1836 AS	01.2013 →	OM 470.903	D	341
1827	01.2013 →	OM 936.912	D	316	1836 AS	01.2013 →	OM 470.910	D	341
1827 A	01.2013 →	OM 936.912	D	316	1836 AS	01.2013 →	OM 470.913	D	341
1827 AK	01.2013 →	OM 936.912	D	316	1836 K	01.2013 →	OM 470.903	D	341
1827 K	01.2013 →	OM 936.912	D	316	1836 K	01.2013 →	OM 470.910	D	341
1827 L	05.2013 →	OM 936.912	D	316	1836 K	01.2013 →	OM 470.913	D	341
1827 L	05.2013 →	OM 936.912	D	316	1836 L	05.2013 →	OM 470.906	D	341
1827 LK	05.2013 →	OM 936.912	D	316	1836 L	05.2013 →	OM 470.906	D	341
1827 LK	05.2013 →	OM 936.912	D	316	1836 L	05.2013 →	OM 470.910	D	341
1827 LS	01.2013 →	OM 936.912	D	316	1836 L	05.2013 →	OM 470.910	D	341
1827 LS	05.2013 →	OM 936.912	D	316	1836 L	05.2013 →	OM 470.913	D	341
1830	01.2013 →	OM 936.912	D	316	1836 L	05.2013 →	OM 470.913	D	341
1830 A	01.2013 →	OM 936.912	D	316	1836 LK	05.2013 →	OM 470.906	D	341
1830 AK	01.2013 →	OM 936.912	D	316	1836 LK	05.2013 →	OM 470.906	D	341
1830 K	01.2013 →	OM 936.912	D	316	1836 LK	05.2013 →	OM 470.910	D	341
1830 L	05.2013 →	OM 936.912	D	316	1836 LK	05.2013 →	OM 470.910	D	341
1830 L	05.2013 →	OM 936.912	D	316	1836 LK	05.2013 →	OM 470.913	D	341
1830 LK	05.2013 →	OM 936.912	D	316	1836 LK	05.2013 →	OM 470.913	D	341
1830 LK	05.2013 →	OM 936.912	D	316	1836 LK	05.2013 →	OM 470.913	D	341
1830 LS	05.2013 →	OM 936.912	D	316	1836 LS	05.2013 →	OM 470.906	D	341
1830 S, 1830 LS	01.2013 →	OM 936.912	D	316	1836 LS	05.2013 →	OM 470.910	D	341
1832	01.2013 →	OM 936.916	D	316	1836 S, 1836 LS	01.2013 →	OM 470.903	D	341
1832 A	01.2013 →	OM 936.916	D	316	1836 S, 1836 LS	01.2013 →	OM 470.910	D	341
1832 AK	01.2013 →	OM 936.916	D	316	1836 S, 1836 LS	01.2013 →	OM 470.913	D	341
1832 K	01.2013 →	OM 936.916	D	316	1840	01.2013 →	OM 470.906	D	341
1832 L	05.2013 →	OM 936.916	D	316	1840 A	01.2013 →	OM 470.906	D	341
1832 L	05.2013 →	OM 936.916	D	316	1840 AK	01.2013 →	OM 470.906	D	341
1832 LK	05.2013 →	OM 936.916	D	316	1840 AS	01.2013 →	OM 470.906	D	341
1832 LK	05.2013 →	OM 936.916	D	316	1840 K	01.2013 →	OM 470.906	D	341
1832 LS	05.2013 →	OM 936.916	D	316	1840 L	05.2013 →	OM 470.906	D	341
1832 S, 1832 LS	01.2013 →	OM 936.916	D	316	1840 L	05.2013 →	OM 470.906	D	341
1833	01.2013 →	OM 470.906	D	341	1840 L	05.2013 →	OM 470.910	D	341
1833 A	01.2013 →	OM 470.906	D	341	1840 L	05.2013 →	OM 470.910	D	341
1833 AK	01.2013 →	OM 470.906	D	341	1840 L	05.2013 →	OM 470.913	D	341
1833 AS	01.2013 →	OM 470.906	D	341	1840 L	05.2013 →	OM 470.913	D	341
1833 K	01.2013 →	OM 470.906	D	341	1840 LK	05.2013 →	OM 470.906	D	341
1833 L	05.2013 →	OM 470.906	D	341	1840 LK	05.2013 →	OM 470.906	D	341
1833 L	05.2013 →	OM 470.906	D	341	1840 LK	05.2013 →	OM 470.910	D	341
1833 L	05.2013 →	OM 470.910	D	341	1840 LK	05.2013 →	OM 470.910	D	341
1833 L	05.2013 →	OM 470.910	D	341	1840 LK	05.2013 →	OM 470.913	D	341
1833 L	05.2013 →	OM 470.913	D	341	1840 LK	05.2013 →	OM 470.913	D	341
1833 L	05.2013 →	OM 470.913	D	341	1840 LS	01.2013 →	OM 470.906	D	341
1833 LK	05.2013 →	OM 470.906	D	341	1840 LS	05.2013 →	OM 470.906	D	341
1833 LK	05.2013 →	OM 470.906	D	341	1840 LS	05.2013 →	OM 470.910	D	341
1833 LK	05.2013 →	OM 470.910	D	341	1840 LS	05.2013 →	OM 470.913	D	341
1833 LK	05.2013 →	OM 470.913	D	341	1842	01.2013 →	OM 471.900	D	556
1833 LK	05.2013 →	OM 470.913	D	341	1842 A	01.2013 →	OM 471.900	D	556
1833 LK	05.2013 →	OM 470.913	D	341	1842 AK	01.2013 →	OM 471.900	D	556
1833 LS	01.2013 →	OM 470.906	D	341	1842 AS	01.2013 →	OM 471.900	D	556
1833 LS	05.2013 →	OM 470.906	D	341	1842 K	01.2013 →	OM 471.900	D	556
1833 LS	05.2013 →	OM 470.910	D	341	1842 L	05.2013 →	OM 471.900	D	556
1833 LS	05.2013 →	OM 470.913	D	341	1842 L	05.2013 →	OM 471.900	D	556
1835	01.2013 →	OM 936.916	D	316	1842 L	05.2013 →	OM 471.922	D	557
1835 A	01.2013 →	OM 936.916	D	316	1842 L	05.2013 →	OM 471.922	D	557
1835 AK	01.2013 →	OM 936.916	D	316	1842 L	05.2013 →	OM 471.926	D	558
1835 K	01.2013 →	OM 936.916	D	316	1842 L	05.2013 →	OM 471.926	D	558
1835 L	05.2013 →	OM 936.916	D	316	1842 LK	05.2013 →	OM 471.900	D	556
1835 L	05.2013 →	OM 936.916	D	316	1842 LK	05.2013 →	OM 471.900	D	556
1835 LK	05.2013 →	OM 936.916	D	316	1842 LK	05.2013 →	OM 471.922	D	557
1835 LK	05.2013 →	OM 936.916	D	316	1842 LK	05.2013 →	OM 471.922	D	557
1835 LS	05.2013 →	OM 936.916	D	316	1842 LK	05.2013 →	OM 471.926	D	558
1835 S, 1835 LS	01.2013 →	OM 936.916	D	316	1842 LK	05.2013 →	OM 471.926	D	558

M

				Pos					Pos
1842 LS	01.2013 →	OM 471.900	D	556	1846 LK	07.2015 →	OM 470.913	D	341
1842 LS	05.2013 →	OM 471.900	D	556	1846 LS	07.2015 →	OM 470.910	D	341
1842 LS	05.2013 →	OM 471.922	D	557	1846 LS	07.2015 →	OM 470.910	D	341
1842 LS	05.2013 →	OM 471.926	D	558	1846 LS	07.2015 →	OM 470.913	D	341
1843	01.2013 →	OM 470.906	D	341	1846 LS	07.2015 →	OM 470.913	D	341
1843 A	01.2013 →	OM 470.906	D	341	1848	01.2013 →	OM 471.900	D	556
1843 AK	01.2013 →	OM 470.906	D	341	1848	01.2013 →	OM 471.906	D	556
1843 AS	01.2013 →	OM 470.906	D	341	1848 A	01.2013 →	OM 471.906	D	556
1843 K	01.2013 →	OM 470.906	D	341	1848 AK	01.2013 →	OM 471.906	D	556
1843 L	05.2013 →	OM 470.906	D	341	1848 AS	01.2013 →	OM 471.906	D	556
1843 L	05.2013 →	OM 470.906	D	341	1848 K	01.2013 →	OM 471.900	D	556
1843 L	05.2013 →	OM 470.910	D	341	1848 K	01.2013 →	OM 471.906	D	556
1843 L	05.2013 →	OM 470.910	D	341	1848 L	05.2013 →	OM 471.900	D	556
1843 L	05.2013 →	OM 470.913	D	341	1848 L	05.2013 →	OM 471.900	D	556
1843 L	05.2013 →	OM 470.913	D	341	1848 L	05.2013 →	OM 471.922	D	557
1843 LK	05.2013 →	OM 470.906	D	341	1848 L	05.2013 →	OM 471.922	D	557
1843 LK	05.2013 →	OM 470.906	D	341	1848 L	05.2013 →	OM 471.926	D	558
1843 LK	05.2013 →	OM 470.910	D	341	1848 L	05.2013 →	OM 471.926	D	558
1843 LK	05.2013 →	OM 470.910	D	341	1848 LK	05.2013 →	OM 471.900	D	556
1843 LK	05.2013 →	OM 470.913	D	341	1848 LK	05.2013 →	OM 471.900	D	556
1843 LK	05.2013 →	OM 470.913	D	341	1848 LK	05.2013 →	OM 471.922	D	557
1843 LK	05.2013 →	OM 470.913	D	341	1848 LK	05.2013 →	OM 471.922	D	557
1843 LS	01.2013 →	OM 470.906	D	341	1848 LK	05.2013 →	OM 471.926	D	558
1843 LS	05.2013 →	OM 470.906	D	341	1848 LK	05.2013 →	OM 471.926	D	558
1843 LS	05.2013 →	OM 470.910	D	341	1848 LK	05.2013 →	OM 471.926	D	558
1843 LS	05.2013 →	OM 470.913	D	341	1848 LS	01.2013 →	OM 471.900	D	556
1845	01.2013 →	OM 471.900	D	556	1848 LS	01.2013 →	OM 471.906	D	556
1845	01.2013 →	OM 471.906	D	556	1848 LS	05.2013 →	OM 471.900	D	556
1845 A	01.2013 →	OM 471.906	D	556	1848 LS	05.2013 →	OM 471.922	D	557
1845 A	01.2013 →	OM 471.926	D	558	1848 LS	05.2013 →	OM 471.926	D	558
1845 AK	01.2013 →	OM 471.906	D	556	1851	01.2013 →	OM 471.909	D	556
1845 AK	01.2013 →	OM 471.926	D	558	1851 A	01.2013 →	OM 471.909	D	556
1845 AS	01.2013 →	OM 471.906	D	556	1851 AK	01.2013 →	OM 471.909	D	556
1845 AS	01.2013 →	OM 471.926	D	558	1851 AS	01.2013 →	OM 471.909	D	556
1845 K	01.2013 →	OM 471.900	D	556	1851 K	01.2013 →	OM 471.909	D	556
1845 K	01.2013 →	OM 471.906	D	556	1851 L	05.2013 →	OM 471.900	D	556
1845 L	05.2013 →	OM 471.900	D	556	1851 L	05.2013 →	OM 471.900	D	556
1845 L	05.2013 →	OM 471.900	D	556	1851 L	05.2013 →	OM 471.922	D	557
1845 L	05.2013 →	OM 471.922	D	557	1851 L	05.2013 →	OM 471.922	D	557
1845 L	05.2013 →	OM 471.922	D	557	1851 L	05.2013 →	OM 471.926	D	558
1845 L	05.2013 →	OM 471.926	D	558	1851 L	05.2013 →	OM 471.926	D	558
1845 L	05.2013 →	OM 471.926	D	558	1851 LK	05.2013 →	OM 471.900	D	556
1845 LK	05.2013 →	OM 471.900	D	556	1851 LK	05.2013 →	OM 471.900	D	556
1845 LK	05.2013 →	OM 471.900	D	556	1851 LK	05.2013 →	OM 471.922	D	557
1845 LK	05.2013 →	OM 471.922	D	557	1851 LK	05.2013 →	OM 471.922	D	557
1845 LK	05.2013 →	OM 471.922	D	557	1851 LK	05.2013 →	OM 471.926	D	558
1845 LK	05.2013 →	OM 471.926	D	558	1851 LK	05.2013 →	OM 471.926	D	558
1845 LK	05.2013 →	OM 471.926	D	558	1851 LS	01.2013 →	OM 471.909	D	556
1845 LS	01.2013 →	OM 471.900	D	556	1851 LS	05.2013 →	OM 471.900	D	556
1845 LS	01.2013 →	OM 471.906	D	556	1851 LS	05.2013 →	OM 471.922	D	557
1845 LS	05.2013 →	OM 471.900	D	556	1851 LS	05.2013 →	OM 471.926	D	558
1845 LS	05.2013 →	OM 471.922	D	557	1852	05.2013 →	OM 473.900	D	567
1845 LS	05.2013 →	OM 471.926	D	558	1852	05.2013 →	OM 473.907	D	568
1846	07.2015 →	OM 470.910	D	341	1852	05.2013 →	OM 473.909	D	569
1846	07.2015 →	OM 470.913	D	341	1852 L	05.2013 →	OM 473.900	D	567
1846 A	07.2015 →	OM 470.910	D	341	1852 L	05.2013 →	OM 473.900	D	567
1846 A	07.2015 →	OM 470.913	D	341	1852 L	05.2013 →	OM 473.907	D	568
1846 AK	07.2015 →	OM 470.910	D	341	1852 L	05.2013 →	OM 473.907	D	568
1846 AK	07.2015 →	OM 470.913	D	341	1852 L	05.2013 →	OM 473.909	D	569
1846 AS	07.2015 →	OM 470.910	D	341	1852 L	05.2013 →	OM 473.909	D	569
1846 AS	07.2015 →	OM 470.913	D	341	1852 LS	05.2013 →	OM 473.900	D	567
1846 K	07.2015 →	OM 470.910	D	341	1852 LS	05.2013 →	OM 473.900	D	567
1846 K	07.2015 →	OM 470.913	D	341	1852 LS	05.2013 →	OM 473.907	D	568
1846 L	07.2015 →	OM 470.910	D	341	1852 LS	05.2013 →	OM 473.907	D	568
1846 L	07.2015 →	OM 470.910	D	341	1852 LS	05.2013 →	OM 473.909	D	569
1846 L	07.2015 →	OM 470.913	D	341	1852 LS	05.2013 →	OM 473.909	D	569
1846 L	07.2015 →	OM 470.913	D	341	1853	07.2015 →	OM 471.922	D	557
1846 LK	07.2015 →	OM 470.910	D	341	1853	07.2015 →	OM 471.926	D	558
1846 LK	07.2015 →	OM 470.910	D	341	1853 A	07.2015 →	OM 471.926	D	558
1846 LK	07.2015 →	OM 470.913	D	341	1853 AK	07.2015 →	OM 471.922	D	557



				Pos					Pos
1853 AK	07.2015 →	OM 471.926	D	558	2030 LS	05.2013 →	OM 936.912	D	316
1853 AS	07.2015 →	OM 471.922	D	557	2030 S, 2030 LS	01.2013 →	OM 936.912	D	316
1853 AS	07.2015 →	OM 471.926	D	558	2032	01.2013 →	OM 936.916	D	316
1853 K	07.2015 →	OM 471.922	D	557	2032 K	01.2013 →	OM 936.916	D	316
1853 K	07.2015 →	OM 471.926	D	558	2032 L	05.2013 →	OM 936.916	D	316
1853 L	07.2015 →	OM 471.922	D	557	2032 L	05.2013 →	OM 936.916	D	316
1853 L	07.2015 →	OM 471.922	D	557	2032 LK	05.2013 →	OM 936.916	D	316
1853 L	07.2015 →	OM 471.926	D	558	2032 LK	05.2013 →	OM 936.916	D	316
1853 L	07.2015 →	OM 471.926	D	558	2032 LS	05.2013 →	OM 936.916	D	316
1853 LK	07.2015 →	OM 471.922	D	557	2032 S, 2032 LS	01.2013 →	OM 936.916	D	316
1853 LK	07.2015 →	OM 471.922	D	557	2033	01.2013 →	OM 470.906	D	341
1853 LK	07.2015 →	OM 471.926	D	558	2033 A	01.2013 →	OM 470.906	D	341
1853 LK	07.2015 →	OM 471.926	D	558	2033 AK	01.2013 →	OM 470.906	D	341
1853 LS	07.2015 →	OM 471.922	D	557	2033 AS	01.2013 →	OM 470.906	D	341
1853 LS	07.2015 →	OM 471.922	D	557	2033 K	01.2013 →	OM 470.906	D	341
1853 LS	07.2015 →	OM 471.926	D	558	2033 L	05.2013 →	OM 470.906	D	341
1853 LS	07.2015 →	OM 471.926	D	558	2033 L	05.2013 →	OM 470.906	D	341
1858	05.2013 →	OM 473.900	D	567	2033 L	05.2013 →	OM 470.910	D	341
1858	05.2013 →	OM 473.907	D	568	2033 L	05.2013 →	OM 470.910	D	341
1858	05.2013 →	OM 473.909	D	569	2033 L	05.2013 →	OM 470.913	D	341
1858 L	05.2013 →	OM 473.900	D	567	2033 L	05.2013 →	OM 470.913	D	341
1858 L	05.2013 →	OM 473.900	D	567	2033 LK	05.2013 →	OM 470.906	D	341
1858 L	05.2013 →	OM 473.907	D	568	2033 LK	05.2013 →	OM 470.906	D	341
1858 L	05.2013 →	OM 473.907	D	568	2033 LK	05.2013 →	OM 470.910	D	341
1858 L	05.2013 →	OM 473.909	D	569	2033 LK	05.2013 →	OM 470.910	D	341
1858 L	05.2013 →	OM 473.909	D	569	2033 LK	05.2013 →	OM 470.913	D	341
1858 L	05.2013 →	OM 473.909	D	569	2033 LK	05.2013 →	OM 470.913	D	341
1858 LS	05.2013 →	OM 473.900	D	567	2033 LK	05.2013 →	OM 470.913	D	341
1858 LS	05.2013 →	OM 473.900	D	567	2033 LS	05.2013 →	OM 470.906	D	341
1858 LS	05.2013 →	OM 473.907	D	568	2033 LS	05.2013 →	OM 470.910	D	341
1858 LS	05.2013 →	OM 473.907	D	568	2033 LS	05.2013 →	OM 470.913	D	341
1858 LS	05.2013 →	OM 473.909	D	569	2033 S, 2033 LS	01.2013 →	OM 470.906	D	341
1858 LS	05.2013 →	OM 473.909	D	569	2035	01.2013 →	OM 936.916	D	316
1863	05.2013 →	OM 473.900	D	567	2035 K	01.2013 →	OM 936.916	D	316
1863	05.2013 →	OM 473.907	D	568	2035 L	05.2013 →	OM 936.916	D	316
1863	05.2013 →	OM 473.909	D	569	2035 L	05.2013 →	OM 936.916	D	316
1863 L	05.2013 →	OM 473.900	D	567	2035 LK	05.2013 →	OM 936.916	D	316
1863 L	05.2013 →	OM 473.900	D	567	2035 LK	05.2013 →	OM 936.916	D	316
1863 L	05.2013 →	OM 473.907	D	568	2035 LS	05.2013 →	OM 936.916	D	316
1863 L	05.2013 →	OM 473.907	D	568	2035 S, 2035 LS	01.2013 →	OM 936.916	D	316
1863 L	05.2013 →	OM 473.909	D	569	2036	01.2013 →	OM 470.903	D	341
1863 L	05.2013 →	OM 473.909	D	569	2036	01.2013 →	OM 470.910	D	341
1863 L	05.2013 →	OM 473.909	D	569	2036	01.2013 →	OM 470.913	D	341
1863 LS	05.2013 →	OM 473.900	D	567	2036 A	01.2013 →	OM 470.903	D	341
1863 LS	05.2013 →	OM 473.900	D	567	2036 A	01.2013 →	OM 470.910	D	341
1863 LS	05.2013 →	OM 473.907	D	568	2036 A	01.2013 →	OM 470.913	D	341
1863 LS	05.2013 →	OM 473.907	D	568	2036 A	01.2013 →	OM 470.913	D	341
1863 LS	05.2013 →	OM 473.909	D	569	2036 AK	01.2013 →	OM 470.903	D	341
1863 LS	05.2013 →	OM 473.909	D	569	2036 AK	01.2013 →	OM 470.910	D	341
2024	01.2013 →	OM 936.912	D	316	2036 AK	01.2013 →	OM 470.913	D	341
2024 K	01.2013 →	OM 936.912	D	316	2036 AS	01.2013 →	OM 470.903	D	341
2024 L	05.2013 →	OM 936.912	D	316	2036 AS	01.2013 →	OM 470.910	D	341
2024 L	05.2013 →	OM 936.912	D	316	2036 AS	01.2013 →	OM 470.913	D	341
2024 LK	05.2013 →	OM 936.912	D	316	2036 K	01.2013 →	OM 470.903	D	341
2024 LK	05.2013 →	OM 936.912	D	316	2036 K	01.2013 →	OM 470.910	D	341
2024 LS	05.2013 →	OM 936.912	D	316	2036 K	01.2013 →	OM 470.913	D	341
2024 S, 2424 LS	01.2013 →	OM 936.912	D	316	2036 L	05.2013 →	OM 470.906	D	341
2027	01.2013 →	OM 936.912	D	316	2036 L	05.2013 →	OM 470.906	D	341
2027 K	01.2013 →	OM 936.912	D	316	2036 L	05.2013 →	OM 470.910	D	341
2027 L	05.2013 →	OM 936.912	D	316	2036 L	05.2013 →	OM 470.910	D	341
2027 L	05.2013 →	OM 936.912	D	316	2036 L	05.2013 →	OM 470.913	D	341
2027 LK	05.2013 →	OM 936.912	D	316	2036 L	05.2013 →	OM 470.913	D	341
2027 LK	05.2013 →	OM 936.912	D	316	2036 LK	05.2013 →	OM 470.906	D	341
2027 LS	05.2013 →	OM 936.912	D	316	2036 LK	05.2013 →	OM 470.906	D	341
2027 S, 2027 LS	01.2013 →	OM 936.912	D	316	2036 LK	05.2013 →	OM 470.910	D	341
2030	01.2013 →	OM 936.912	D	316	2036 LK	05.2013 →	OM 470.910	D	341
2030 K	01.2013 →	OM 936.912	D	316	2036 LK	05.2013 →	OM 470.913	D	341
2030 L	05.2013 →	OM 936.912	D	316	2036 LK	05.2013 →	OM 470.913	D	341
2030 L	05.2013 →	OM 936.912	D	316	2036 LS	05.2013 →	OM 470.906	D	341
2030 LK	05.2013 →	OM 936.912	D	316	2036 LS	05.2013 →	OM 470.910	D	341
2030 LK	05.2013 →	OM 936.912	D	316	2036 LS	05.2013 →	OM 470.913	D	341

M

# MERCEDES-BENZ

		Pos			Pos		
2036 S, 2036 LS	01.2013 →	OM 470.903 D	<b>341</b>	2045 A	01.2013 →	OM 471.926 D	<b>558</b>
2036 S, 2036 LS	01.2013 →	OM 470.910 D	<b>341</b>	2045 AK	01.2013 →	OM 471.906 D	<b>556</b>
2036 S, 2036 LS	01.2013 →	OM 470.913 D	<b>341</b>	2045 AK	01.2013 →	OM 471.926 D	<b>558</b>
2040	01.2013 →	OM 470.906 D	<b>341</b>	2045 AS	01.2013 →	OM 471.906 D	<b>556</b>
2040 A	01.2013 →	OM 470.906 D	<b>341</b>	2045 AS	01.2013 →	OM 471.926 D	<b>558</b>
2040 AK	01.2013 →	OM 470.906 D	<b>341</b>	2045 K	01.2013 →	OM 471.900 D	<b>556</b>
2040 AS	01.2013 →	OM 470.906 D	<b>341</b>	2045 K	01.2013 →	OM 471.906 D	<b>556</b>
2040 K	01.2013 →	OM 470.906 D	<b>341</b>	2045 L	05.2013 →	OM 471.900 D	<b>556</b>
2040 L	05.2013 →	OM 470.906 D	<b>341</b>	2045 L	05.2013 →	OM 471.900 D	<b>556</b>
2040 L	05.2013 →	OM 470.906 D	<b>341</b>	2045 L	05.2013 →	OM 471.922 D	<b>557</b>
2040 L	05.2013 →	OM 470.910 D	<b>341</b>	2045 L	05.2013 →	OM 471.922 D	<b>557</b>
2040 L	05.2013 →	OM 470.910 D	<b>341</b>	2045 L	05.2013 →	OM 471.926 D	<b>558</b>
2040 L	05.2013 →	OM 470.913 D	<b>341</b>	2045 L	05.2013 →	OM 471.926 D	<b>558</b>
2040 L	05.2013 →	OM 470.913 D	<b>341</b>	2045 LK	05.2013 →	OM 471.900 D	<b>556</b>
2040 LK	05.2013 →	OM 470.906 D	<b>341</b>	2045 LK	05.2013 →	OM 471.900 D	<b>556</b>
2040 LK	05.2013 →	OM 470.906 D	<b>341</b>	2045 LK	05.2013 →	OM 471.922 D	<b>557</b>
2040 LK	05.2013 →	OM 470.910 D	<b>341</b>	2045 LK	05.2013 →	OM 471.922 D	<b>557</b>
2040 LK	05.2013 →	OM 470.910 D	<b>341</b>	2045 LK	05.2013 →	OM 471.926 D	<b>558</b>
2040 LK	05.2013 →	OM 470.913 D	<b>341</b>	2045 LK	05.2013 →	OM 471.926 D	<b>558</b>
2040 LK	05.2013 →	OM 470.913 D	<b>341</b>	2045 LS	05.2013 →	OM 471.900 D	<b>556</b>
2040 LS	05.2013 →	OM 470.906 D	<b>341</b>	2045 LS	05.2013 →	OM 471.922 D	<b>557</b>
2040 LS	05.2013 →	OM 470.910 D	<b>341</b>	2045 LS	05.2013 →	OM 471.926 D	<b>558</b>
2040 LS	05.2013 →	OM 470.913 D	<b>341</b>	2045 S, 2045 LS	01.2013 →	OM 471.900 D	<b>556</b>
2040 S, 2040 LS	01.2013 →	OM 470.906 D	<b>341</b>	2045 S, 2045 LS	01.2013 →	OM 471.906 D	<b>556</b>
2042	01.2013 →	OM 471.900 D	<b>556</b>	2046	07.2015 →	OM 470.910 D	<b>341</b>
2042 A	01.2013 →	OM 471.900 D	<b>556</b>	2046	07.2015 →	OM 470.913 D	<b>341</b>
2042 AK	01.2013 →	OM 471.900 D	<b>556</b>	2046 A	07.2015 →	OM 470.910 D	<b>341</b>
2042 AS	01.2013 →	OM 471.900 D	<b>556</b>	2046 A	07.2015 →	OM 470.913 D	<b>341</b>
2042 K	01.2013 →	OM 471.900 D	<b>556</b>	2046 AK	07.2015 →	OM 470.910 D	<b>341</b>
2042 L	05.2013 →	OM 471.900 D	<b>556</b>	2046 AK	07.2015 →	OM 470.913 D	<b>341</b>
2042 L	05.2013 →	OM 471.900 D	<b>556</b>	2046 AS	07.2015 →	OM 470.910 D	<b>341</b>
2042 L	05.2013 →	OM 471.922 D	<b>557</b>	2046 AS	07.2015 →	OM 470.913 D	<b>341</b>
2042 L	05.2013 →	OM 471.922 D	<b>557</b>	2046 K	07.2015 →	OM 470.910 D	<b>341</b>
2042 L	05.2013 →	OM 471.926 D	<b>558</b>	2046 K	07.2015 →	OM 470.913 D	<b>341</b>
2042 L	05.2013 →	OM 471.926 D	<b>558</b>	2046 L	07.2015 →	OM 470.910 D	<b>341</b>
2042 LK	05.2013 →	OM 471.900 D	<b>556</b>	2046 L	07.2015 →	OM 470.910 D	<b>341</b>
2042 LK	05.2013 →	OM 471.900 D	<b>556</b>	2046 L	07.2015 →	OM 470.913 D	<b>341</b>
2042 LK	05.2013 →	OM 471.922 D	<b>557</b>	2046 L	07.2015 →	OM 470.913 D	<b>341</b>
2042 LK	05.2013 →	OM 471.922 D	<b>557</b>	2046 LK	07.2015 →	OM 470.910 D	<b>341</b>
2042 LK	05.2013 →	OM 471.926 D	<b>558</b>	2046 LK	07.2015 →	OM 470.910 D	<b>341</b>
2042 LK	05.2013 →	OM 471.926 D	<b>558</b>	2046 LK	07.2015 →	OM 470.913 D	<b>341</b>
2042 LS	05.2013 →	OM 471.900 D	<b>556</b>	2046 LK	07.2015 →	OM 470.913 D	<b>341</b>
2042 LS	05.2013 →	OM 471.922 D	<b>557</b>	2046 LS	07.2015 →	OM 470.910 D	<b>341</b>
2042 LS	05.2013 →	OM 471.926 D	<b>558</b>	2046 LS	07.2015 →	OM 470.910 D	<b>341</b>
2042 S, 2042 LS	01.2013 →	OM 471.900 D	<b>556</b>	2046 LS	07.2015 →	OM 470.913 D	<b>341</b>
2043	01.2013 →	OM 470.906 D	<b>341</b>	2046 S	07.2015 →	OM 470.910 D	<b>341</b>
2043 A	01.2013 →	OM 470.906 D	<b>341</b>	2046 S	07.2015 →	OM 470.913 D	<b>341</b>
2043 AK	01.2013 →	OM 470.906 D	<b>341</b>	2048	01.2013 →	OM 471.900 D	<b>556</b>
2043 AS	01.2013 →	OM 470.906 D	<b>341</b>	2048	01.2013 →	OM 471.926 D	<b>558</b>
2043 K	01.2013 →	OM 470.906 D	<b>341</b>	2048 A	01.2013 →	OM 471.906 D	<b>556</b>
2043 L	05.2013 →	OM 470.906 D	<b>341</b>	2048 A	01.2013 →	OM 471.926 D	<b>558</b>
2043 L	05.2013 →	OM 470.906 D	<b>341</b>	2048 AK	01.2013 →	OM 471.906 D	<b>556</b>
2043 L	05.2013 →	OM 470.910 D	<b>341</b>	2048 AK	01.2013 →	OM 471.926 D	<b>558</b>
2043 L	05.2013 →	OM 470.910 D	<b>341</b>	2048 AS	01.2013 →	OM 471.906 D	<b>556</b>
2043 L	05.2013 →	OM 470.913 D	<b>341</b>	2048 AS	01.2013 →	OM 471.926 D	<b>558</b>
2043 L	05.2013 →	OM 470.913 D	<b>341</b>	2048 K	01.2013 →	OM 471.900 D	<b>556</b>
2043 LK	05.2013 →	OM 470.906 D	<b>341</b>	2048 K	01.2013 →	OM 471.906 D	<b>556</b>
2043 LK	05.2013 →	OM 470.906 D	<b>341</b>	2048 L	05.2013 →	OM 471.900 D	<b>556</b>
2043 LK	05.2013 →	OM 470.910 D	<b>341</b>	2048 L	05.2013 →	OM 471.900 D	<b>556</b>
2043 LK	05.2013 →	OM 470.910 D	<b>341</b>	2048 L	05.2013 →	OM 471.922 D	<b>557</b>
2043 LK	05.2013 →	OM 470.913 D	<b>341</b>	2048 L	05.2013 →	OM 471.922 D	<b>557</b>
2043 LK	05.2013 →	OM 470.913 D	<b>341</b>	2048 L	05.2013 →	OM 471.926 D	<b>558</b>
2043 LS	05.2013 →	OM 470.906 D	<b>341</b>	2048 L	05.2013 →	OM 471.926 D	<b>558</b>
2043 LS	05.2013 →	OM 470.910 D	<b>341</b>	2048 L	05.2013 →	OM 471.926 D	<b>558</b>
2043 LS	05.2013 →	OM 470.913 D	<b>341</b>	2048 LK	05.2013 →	OM 471.900 D	<b>556</b>
2043 S, 2043 LS	01.2013 →	OM 470.906 D	<b>341</b>	2048 LK	05.2013 →	OM 471.900 D	<b>556</b>
2045	01.2013 →	OM 471.900 D	<b>556</b>	2048 LK	05.2013 →	OM 471.922 D	<b>557</b>
2045	01.2013 →	OM 471.906 D	<b>556</b>	2048 LK	05.2013 →	OM 471.922 D	<b>557</b>
2045 A	01.2013 →	OM 471.906 D	<b>556</b>	2048 LK	05.2013 →	OM 471.926 D	<b>558</b>

M



			Pos				Pos		
2048 LK	05.2013 →	OM 471.926	D	558	2058	05.2013 →	OM 473.900	D	567
2048 LS	05.2013 →	OM 471.900	D	556	2058	05.2013 →	OM 473.907	D	568
2048 LS	05.2013 →	OM 471.922	D	557	2058	05.2013 →	OM 473.909	D	569
2048 LS	05.2013 →	OM 471.926	D	558	2058 L	05.2013 →	OM 473.908	D	567
2048 S, 2048 LS	01.2013 →	OM 471.900	D	556	2058 L	05.2013 →	OM 473.900	D	567
2048 S, 2048 LS	01.2013 →	OM 471.926	D	558	2058 L	05.2013 →	OM 473.907	D	568
2051	01.2013 →	OM 471.909	D	556	2058 L	05.2013 →	OM 473.907	D	568
2051 A	01.2013 →	OM 471.909	D	556	2058 L	05.2013 →	OM 473.909	D	569
2051 AK	01.2013 →	OM 471.909	D	556	2058 L	05.2013 →	OM 473.909	D	569
2051 AS	01.2013 →	OM 471.909	D	556	2058 LS	05.2013 →	OM 473.900	D	567
2051 K	01.2013 →	OM 471.909	D	556	2058 LS	05.2013 →	OM 473.900	D	567
2051 L	05.2013 →	OM 471.900	D	556	2058 LS	05.2013 →	OM 473.907	D	568
2051 L	05.2013 →	OM 471.900	D	556	2058 LS	05.2013 →	OM 473.907	D	568
2051 L	05.2013 →	OM 471.922	D	557	2058 LS	05.2013 →	OM 473.909	D	569
2051 L	05.2013 →	OM 471.922	D	557	2058 LS	05.2013 →	OM 473.909	D	569
2051 L	05.2013 →	OM 471.926	D	558	2058 S	05.2013 →	OM 473.900	D	567
2051 L	05.2013 →	OM 471.926	D	558	2058 S	05.2013 →	OM 473.907	D	568
2051 LK	05.2013 →	OM 471.900	D	556	2058 S	05.2013 →	OM 473.909	D	569
2051 LK	05.2013 →	OM 471.900	D	556	2063	05.2013 →	OM 473.900	D	567
2051 LK	05.2013 →	OM 471.922	D	557	2063	05.2013 →	OM 473.907	D	568
2051 LK	05.2013 →	OM 471.922	D	557	2063	05.2013 →	OM 473.909	D	569
2051 LK	05.2013 →	OM 471.926	D	558	2063 L	05.2013 →	OM 473.900	D	567
2051 LK	05.2013 →	OM 471.926	D	558	2063 L	05.2013 →	OM 473.900	D	567
2051 LS	05.2013 →	OM 471.900	D	556	2063 L	05.2013 →	OM 473.907	D	568
2051 LS	05.2013 →	OM 471.922	D	557	2063 L	05.2013 →	OM 473.907	D	568
2051 LS	05.2013 →	OM 471.926	D	558	2063 L	05.2013 →	OM 473.909	D	569
2051 S, 2051 LS	01.2013 →	OM 471.909	D	556	2063 L	05.2013 →	OM 473.909	D	569
2052	05.2013 →	OM 473.900	D	567	2063 LS	05.2013 →	OM 473.900	D	567
2052	05.2013 →	OM 473.907	D	568	2063 LS	05.2013 →	OM 473.900	D	567
2052	05.2013 →	OM 473.909	D	569	2063 LS	05.2013 →	OM 473.907	D	568
2052 L	05.2013 →	OM 473.900	D	567	2063 LS	05.2013 →	OM 473.907	D	568
2052 L	05.2013 →	OM 473.900	D	567	2063 LS	05.2013 →	OM 473.909	D	569
2052 L	05.2013 →	OM 473.907	D	568	2063 LS	05.2013 →	OM 473.909	D	569
2052 L	05.2013 →	OM 473.907	D	568	2063 S	05.2013 →	OM 473.900	D	567
2052 L	05.2013 →	OM 473.909	D	569	2063 S	05.2013 →	OM 473.907	D	568
2052 L	05.2013 →	OM 473.909	D	569	2063 S	05.2013 →	OM 473.909	D	569
2052 LS	05.2013 →	OM 473.900	D	567	2524 L	05.2013 →	OM 936.912	D	316
2052 LS	05.2013 →	OM 473.900	D	567	2524 L	05.2013 →	OM 936.912	D	316
2052 LS	05.2013 →	OM 473.907	D	568	2524 L	05.2013 →	OM 936.912	D	316
2052 LS	05.2013 →	OM 473.907	D	568	2524 LS	05.2013 →	OM 936.912	D	316
2052 LS	05.2013 →	OM 473.909	D	569	2524 LS	05.2013 →	OM 936.912	D	316
2052 LS	05.2013 →	OM 473.909	D	569	2527 L	01.2013 →	OM 936.912	D	316
2052 S	05.2013 →	OM 473.900	D	567	2527 L	01.2013 →	OM 936.912	D	316
2052 S	05.2013 →	OM 473.907	D	568	2527 L	01.2013 →	OM 936.912	D	316
2052 S	05.2013 →	OM 473.909	D	569	2527 L	05.2013 →	OM 936.912	D	316
2053	07.2015 →	OM 471.922	D	557	2527 L	05.2013 →	OM 936.912	D	316
2053	07.2015 →	OM 471.926	D	558	2527 LS	01.2013 →	OM 936.912	D	316
2053 A	07.2015 →	OM 471.922	D	557	2527 LS	05.2013 →	OM 936.912	D	316
2053 A	07.2015 →	OM 471.926	D	558	2530 L	01.2013 →	OM 936.912	D	316
2053 AK	07.2015 →	OM 471.922	D	557	2530 L	01.2013 →	OM 936.912	D	316
2053 AK	07.2015 →	OM 471.926	D	558	2530 L	05.2013 →	OM 936.912	D	316
2053 AS	07.2015 →	OM 471.922	D	557	2530 L	05.2013 →	OM 936.912	D	316
2053 AS	07.2015 →	OM 471.926	D	558	2530 LS	01.2013 →	OM 936.912	D	316
2053 K	07.2015 →	OM 471.922	D	557	2530 LS	05.2013 →	OM 936.912	D	316
2053 K	07.2015 →	OM 471.926	D	558	2532 K	09.2019 →	OM 936.916	D	316
2053 L	07.2015 →	OM 471.922	D	557	2532 L	01.2013 →	OM 936.916	D	316
2053 L	07.2015 →	OM 471.922	D	557	2532 L	01.2013 →	OM 936.916	D	316
2053 L	07.2015 →	OM 471.926	D	558	2532 L	05.2013 →	OM 936.916	D	316
2053 L	07.2015 →	OM 471.926	D	558	2532 L	05.2013 →	OM 936.916	D	316
2053 LK	07.2015 →	OM 471.922	D	557	2532 LS	01.2013 →	OM 936.916	D	316
2053 LK	07.2015 →	OM 471.922	D	557	2532 LS	05.2013 →	OM 936.916	D	316
2053 LK	07.2015 →	OM 471.926	D	558	2533 L	01.2013 →	OM 470.906	D	341
2053 LK	07.2015 →	OM 471.926	D	558	2533 L	01.2013 →	OM 470.906	D	341
2053 LS	07.2015 →	OM 471.922	D	557	2533 L	05.2013 →	OM 470.906	D	341
2053 LS	07.2015 →	OM 471.922	D	557	2533 L	05.2013 →	OM 470.906	D	341
2053 LS	07.2015 →	OM 471.926	D	558	2533 L	05.2013 →	OM 470.906	D	341
2053 LS	07.2015 →	OM 471.926	D	558	2533 L	05.2013 →	OM 470.910	D	341
2053 S	07.2015 →	OM 471.922	D	557	2533 L	05.2013 →	OM 470.910	D	341
2053 S	07.2015 →	OM 471.926	D	558	2533 L	05.2013 →	OM 470.913	D	341
2053 S	07.2015 →	OM 471.926	D	558	2533 L	05.2013 →	OM 470.913	D	341

M



			Pos				Pos		
2551 LS	01.2013 →	OM 471.909	D	556	2627 K, 2627 LK	01.2013 →	OM 936.912	D	316
2551 LS	05.2013 →	OM 471.900	D	556	2627 L	01.2013 →	OM 936.912	D	316
2551 LS	05.2013 →	OM 471.922	D	557	2627 L	05.2013 →	OM 936.912	D	316
2551 LS	05.2013 →	OM 471.926	D	558	2627 LK	05.2013 →	OM 936.912	D	316
2552 L	05.2013 →	OM 473.900	D	567	2627 LS	01.2013 →	OM 936.912	D	316
2552 L	05.2013 →	OM 473.900	D	567	2627 LS	05.2013 →	OM 936.912	D	316
2552 L	05.2013 →	OM 473.900	D	567	2627 S, 2627 LS	01.2013 →	OM 936.912	D	316
2552 L	05.2013 →	OM 473.907	D	568	2627, 2627 L	01.2013 →	OM 936.912	D	316
2552 L	05.2013 →	OM 473.907	D	568	2630 K, 2630 LK	01.2013 →	OM 936.912	D	316
2552 L	05.2013 →	OM 473.907	D	568	2630 L	01.2013 →	OM 936.912	D	316
2552 L	05.2013 →	OM 473.909	D	569	2630 L	05.2013 →	OM 936.912	D	316
2552 L	05.2013 →	OM 473.909	D	569	2630 LK	05.2013 →	OM 936.912	D	316
2552 L	05.2013 →	OM 473.909	D	569	2630 LS	01.2013 →	OM 936.912	D	316
2552 L	01.2014 →	OM 473.900	D	567	2630 LS	05.2013 →	OM 936.912	D	316
2552 L	01.2014 →	OM 473.907	D	568	2630 S, 2630 LS	01.2013 →	OM 936.912	D	316
2552 L	01.2014 →	OM 473.909	D	569	2630, 2630 L	01.2013 →	OM 936.912	D	316
2552 LS	05.2013 →	OM 473.900	D	567	2632 K, 2632 LK	01.2013 →	OM 936.916	D	316
2552 LS	05.2013 →	OM 473.900	D	567	2632 L	01.2013 →	OM 936.916	D	316
2553 L	07.2015 →	OM 471.922	D	557	2632 L	05.2013 →	OM 936.916	D	316
2553 L	07.2015 →	OM 471.922	D	557	2632 LK	05.2013 →	OM 936.916	D	316
2553 L	07.2015 →	OM 471.922	D	557	2632 LS	01.2013 →	OM 936.916	D	316
2553 L	07.2015 →	OM 471.922	D	557	2632 LS	05.2013 →	OM 936.916	D	316
2553 L	07.2015 →	OM 471.926	D	558	2632 S, 2632 LS	01.2013 →	OM 936.916	D	316
2553 L	07.2015 →	OM 471.926	D	558	2632, 2632 L	01.2013 →	OM 936.916	D	316
2553 L	07.2015 →	OM 471.926	D	558	2633 K, 2633 LK	01.2013 →	OM 470.906	D	341
2553 L	07.2015 →	OM 471.926	D	558	2633 L	01.2013 →	OM 470.906	D	341
2553 LS	07.2015 →	OM 471.922	D	557	2633 L	05.2013 →	OM 470.906	D	341
2553 LS	07.2015 →	OM 471.922	D	557	2633 L	05.2013 →	OM 470.910	D	341
2553 LS	07.2015 →	OM 471.922	D	557	2633 L	05.2013 →	OM 470.913	D	341
2553 LS	07.2015 →	OM 471.926	D	558	2633 LK	05.2013 →	OM 470.906	D	341
2553 LS	07.2015 →	OM 471.926	D	558	2633 LK	05.2013 →	OM 470.906	D	341
2553 LS	07.2015 →	OM 471.926	D	558	2633 LK	05.2013 →	OM 470.910	D	341
2553 LS	07.2015 →	OM 471.926	D	558	2633 LK	05.2013 →	OM 470.913	D	341
2558 L	05.2013 →	OM 473.900	D	567	2633 LS	01.2013 →	OM 470.906	D	341
2558 L	05.2013 →	OM 473.900	D	567	2633 LS	05.2013 →	OM 470.906	D	341
2558 L	05.2013 →	OM 473.900	D	567	2633 LS	05.2013 →	OM 470.910	D	341
2558 L	05.2013 →	OM 473.907	D	568	2633 LS	05.2013 →	OM 470.913	D	341
2558 L	05.2013 →	OM 473.907	D	568	2633 S, 2633 LS	01.2013 →	OM 470.906	D	341
2558 L	05.2013 →	OM 473.907	D	568	2633, 2633 L	01.2013 →	OM 470.906	D	341
2558 L	05.2013 →	OM 473.909	D	569	2635 K, 2635 LK	01.2013 →	OM 936.916	D	316
2558 L	05.2013 →	OM 473.909	D	569	2635 L	01.2013 →	OM 936.916	D	316
2558 L	05.2013 →	OM 473.909	D	569	2635 L	05.2013 →	OM 936.916	D	316
2558 L	01.2014 →	OM 473.900	D	567	2635 LK	05.2013 →	OM 936.916	D	316
2558 L	01.2014 →	OM 473.907	D	568	2635 LS	01.2013 →	OM 936.916	D	316
2558 LS	05.2013 →	OM 473.900	D	567	2635 LS	05.2013 →	OM 936.916	D	316
2558 LS	05.2013 →	OM 473.900	D	567	2635 S, 2635 LS	01.2013 →	OM 936.916	D	316
2563 L	05.2013 →	OM 473.900	D	567	2635, 2635 L	01.2013 →	OM 936.916	D	316
2563 L	05.2013 →	OM 473.900	D	567	2636 K, 2636 LK	01.2013 →	OM 470.906	D	341
2563 L	05.2013 →	OM 473.900	D	567	2636 L	01.2013 →	OM 470.906	D	341
2563 L	05.2013 →	OM 473.907	D	568	2636 L	05.2013 →	OM 470.906	D	341
2563 L	05.2013 →	OM 473.907	D	568	2636 L	05.2013 →	OM 470.910	D	341
2563 L	05.2013 →	OM 473.907	D	568	2636 L	05.2013 →	OM 470.913	D	341
2563 L	05.2013 →	OM 473.909	D	569	2636 LK	05.2013 →	OM 470.906	D	341
2563 L	05.2013 →	OM 473.909	D	569	2636 LK	05.2013 →	OM 470.910	D	341
2563 L	05.2013 →	OM 473.909	D	569	2636 LK	05.2013 →	OM 470.913	D	341
2563 L	01.2014 →	OM 473.900	D	567	2636 LS	01.2013 →	OM 470.906	D	341
2563 L	01.2014 →	OM 473.907	D	568	2636 LS	05.2013 →	OM 470.906	D	341
2563 LS	05.2013 →	OM 473.900	D	567	2636 LS	05.2013 →	OM 470.910	D	341
2563 LS	05.2013 →	OM 473.900	D	567	2636 LS	05.2013 →	OM 470.913	D	341
2624	05.2013 →	OM 936.912	D	316	2636 S, 2636 LS	01.2013 →	OM 470.906	D	341
2624 K	05.2013 →	OM 936.912	D	316	2636, 2636 L	01.2013 →	OM 470.906	D	341
2624 L	05.2013 →	OM 936.912	D	316	2640 K, 2640 LK	01.2013 →	OM 470.906	D	341
2624 L	05.2013 →	OM 936.912	D	316	2640 L	01.2013 →	OM 470.906	D	341
2624 L	05.2013 →	OM 936.912	D	316	2640 L	05.2013 →	OM 470.906	D	341
2624 LK	05.2013 →	OM 936.912	D	316	2640 L	05.2013 →	OM 470.910	D	341
2624 LK	05.2013 →	OM 936.912	D	316	2640 L	05.2013 →	OM 470.913	D	341
2624 LS	05.2013 →	OM 936.912	D	316	2640 LK	05.2013 →	OM 470.906	D	341
2624 LS	05.2013 →	OM 936.912	D	316	2640 LK	05.2013 →	OM 470.910	D	341
2624 LS	05.2013 →	OM 936.912	D	316	2640 LK	05.2013 →	OM 470.913	D	341
2624 S	05.2013 →	OM 936.912	D	316	2640 LS	01.2013 →	OM 470.906	D	341

M



		Pos			Pos				
2640 LS	05.2013 →	OM 470.906	D	<b>341</b>	2646 LS	07.2015 →	OM 470.913	D	<b>341</b>
2640 LS	05.2013 →	OM 470.910	D	<b>341</b>	2646 S	07.2015 →	OM 470.910	D	<b>341</b>
2640 LS	05.2013 →	OM 470.913	D	<b>341</b>	2646 S	07.2015 →	OM 470.913	D	<b>341</b>
2640 S, 2640 LS	01.2013 →	OM 470.906	D	<b>341</b>	2648 K, 2648 LK	01.2013 →	OM 471.900	D	<b>556</b>
2640, 2640 L	01.2013 →	OM 470.906	D	<b>341</b>	2648 K, 2648 LK	01.2013 →	OM 471.926	D	<b>558</b>
2642	01.2013 →	OM 471.900	D	<b>556</b>	2648 L	01.2013 →	OM 471.900	D	<b>556</b>
2642 K, 2642 LK	01.2013 →	OM 471.900	D	<b>556</b>	2648 L	01.2013 →	OM 471.926	D	<b>558</b>
2642 L	01.2013 →	OM 471.900	D	<b>556</b>	2648 L	05.2013 →	OM 471.900	D	<b>556</b>
2642 L	05.2013 →	OM 471.900	D	<b>556</b>	2648 L	05.2013 →	OM 471.922	D	<b>557</b>
2642 L	05.2013 →	OM 471.922	D	<b>557</b>	2648 L	05.2013 →	OM 471.926	D	<b>558</b>
2642 L	05.2013 →	OM 471.926	D	<b>558</b>	2648 LK	05.2013 →	OM 471.900	D	<b>556</b>
2642 LK	05.2013 →	OM 471.900	D	<b>556</b>	2648 LK	05.2013 →	OM 471.922	D	<b>557</b>
2642 LK	05.2013 →	OM 471.922	D	<b>557</b>	2648 LK	05.2013 →	OM 471.926	D	<b>558</b>
2642 LK	05.2013 →	OM 471.926	D	<b>558</b>	2648 LS	01.2013 →	OM 471.900	D	<b>556</b>
2642 LS	01.2013 →	OM 471.900	D	<b>556</b>	2648 LS	01.2013 →	OM 471.900	D	<b>556</b>
2642 LS	05.2013 →	OM 471.900	D	<b>556</b>	2648 LS	01.2013 →	OM 471.926	D	<b>558</b>
2642 LS	05.2013 →	OM 471.922	D	<b>557</b>	2648 LS	05.2013 →	OM 471.900	D	<b>556</b>
2642 LS	05.2013 →	OM 471.926	D	<b>558</b>	2648 LS	05.2013 →	OM 471.922	D	<b>557</b>
2642 S, 2642 LS	01.2013 →	OM 471.900	D	<b>556</b>	2648 LS	05.2013 →	OM 471.926	D	<b>558</b>
2642, 2642 L	01.2013 →	OM 471.900	D	<b>556</b>	2648 S, 2648 LS	01.2013 →	OM 471.900	D	<b>556</b>
2643 K, 2643 LK	01.2013 →	OM 470.906	D	<b>341</b>	2648 S, 2648 LS	01.2013 →	OM 471.926	D	<b>558</b>
2643 L	01.2013 →	OM 470.906	D	<b>341</b>	2648, 2648 L	01.2013 →	OM 471.900	D	<b>556</b>
2643 L	05.2013 →	OM 470.906	D	<b>341</b>	2648, 2648 L	01.2013 →	OM 471.926	D	<b>558</b>
2643 L	05.2013 →	OM 470.910	D	<b>341</b>	2651 K, 2651 LK	01.2013 →	OM 471.909	D	<b>556</b>
2643 L	05.2013 →	OM 470.913	D	<b>341</b>	2651 L	01.2013 →	OM 471.909	D	<b>556</b>
2643 LK	05.2013 →	OM 470.906	D	<b>341</b>	2651 L	05.2013 →	OM 471.900	D	<b>556</b>
2643 LK	05.2013 →	OM 470.910	D	<b>341</b>	2651 L	05.2013 →	OM 471.922	D	<b>557</b>
2643 LK	05.2013 →	OM 470.913	D	<b>341</b>	2651 L	05.2013 →	OM 471.926	D	<b>558</b>
2643 LS	01.2013 →	OM 470.906	D	<b>341</b>	2651 LK	05.2013 →	OM 471.900	D	<b>556</b>
2643 LS	05.2013 →	OM 470.906	D	<b>341</b>	2651 LK	05.2013 →	OM 471.922	D	<b>557</b>
2643 LS	05.2013 →	OM 470.910	D	<b>341</b>	2651 LK	05.2013 →	OM 471.926	D	<b>558</b>
2643 LS	05.2013 →	OM 470.913	D	<b>341</b>	2651 LS	01.2013 →	OM 471.909	D	<b>556</b>
2643 S, 2643 LS	01.2013 →	OM 470.906	D	<b>341</b>	2651 LS	05.2013 →	OM 471.900	D	<b>556</b>
2643, 2643 L	01.2013 →	OM 470.906	D	<b>341</b>	2651 LS	05.2013 →	OM 471.922	D	<b>557</b>
2645 K, 2645 LK	01.2013 →	OM 471.900	D	<b>556</b>	2651 LS	05.2013 →	OM 471.926	D	<b>558</b>
2645 L	01.2013 →	OM 471.900	D	<b>556</b>	2651 S, 2651 LS	01.2013 →	OM 471.909	D	<b>556</b>
2645 L	05.2013 →	OM 471.900	D	<b>556</b>	2651, 2651 L	01.2013 →	OM 471.909	D	<b>556</b>
2645 L	05.2013 →	OM 471.922	D	<b>557</b>	2652	05.2013 →	OM 473.900	D	<b>567</b>
2645 L	05.2013 →	OM 471.926	D	<b>558</b>	2652	05.2013 →	OM 473.907	D	<b>568</b>
2645 LK	05.2013 →	OM 471.900	D	<b>556</b>	2652	05.2013 →	OM 473.909	D	<b>569</b>
2645 LK	05.2013 →	OM 471.922	D	<b>557</b>	2652 K	05.2013 →	OM 473.900	D	<b>567</b>
2645 LK	05.2013 →	OM 471.926	D	<b>558</b>	2652 K	05.2013 →	OM 473.907	D	<b>568</b>
2645 LS	01.2013 →	OM 471.900	D	<b>556</b>	2652 K	05.2013 →	OM 473.909	D	<b>569</b>
2645 LS	05.2013 →	OM 471.900	D	<b>556</b>	2652 L	05.2013 →	OM 473.900	D	<b>567</b>
2645 LS	05.2013 →	OM 471.922	D	<b>557</b>	2652 L	05.2013 →	OM 473.900	D	<b>567</b>
2645 LS	05.2013 →	OM 471.926	D	<b>558</b>	2652 L	05.2013 →	OM 473.907	D	<b>568</b>
2645 S, 2645 LS	01.2013 →	OM 471.900	D	<b>556</b>	2652 L	05.2013 →	OM 473.907	D	<b>568</b>
2645 S, 2645 LS	01.2013 →	OM 471.906	D	<b>556</b>	2652 L	05.2013 →	OM 473.907	D	<b>568</b>
2645, 2645 L	01.2013 →	OM 471.900	D	<b>556</b>	2652 L	05.2013 →	OM 473.907	D	<b>568</b>
2645, 2645 L	01.2013 →	OM 471.906	D	<b>556</b>	2652 L	05.2013 →	OM 473.909	D	<b>569</b>
2646	07.2015 →	OM 470.910	D	<b>341</b>	2652 L	05.2013 →	OM 473.909	D	<b>569</b>
2646	07.2015 →	OM 470.913	D	<b>341</b>	2652 L	05.2013 →	OM 473.909	D	<b>569</b>
2646 K	07.2015 →	OM 470.910	D	<b>341</b>	2652 LK	05.2013 →	OM 473.900	D	<b>567</b>
2646 K	07.2015 →	OM 470.913	D	<b>341</b>	2652 LK	05.2013 →	OM 473.900	D	<b>567</b>
2646 L	07.2015 →	OM 470.910	D	<b>341</b>	2652 LK	05.2013 →	OM 473.907	D	<b>568</b>
2646 L	07.2015 →	OM 470.910	D	<b>341</b>	2652 LK	05.2013 →	OM 473.907	D	<b>568</b>
2646 L	07.2015 →	OM 470.910	D	<b>341</b>	2652 LK	05.2013 →	OM 473.909	D	<b>569</b>
2646 L	07.2015 →	OM 470.913	D	<b>341</b>	2652 LK	05.2013 →	OM 473.909	D	<b>569</b>
2646 L	07.2015 →	OM 470.913	D	<b>341</b>	2652 LS	05.2013 →	OM 473.900	D	<b>567</b>
2646 L	07.2015 →	OM 470.913	D	<b>341</b>	2652 LS	05.2013 →	OM 473.900	D	<b>567</b>
2646 LK	07.2015 →	OM 470.910	D	<b>341</b>	2652 LS	05.2013 →	OM 473.900	D	<b>567</b>
2646 LK	07.2015 →	OM 470.910	D	<b>341</b>	2652 LS	05.2013 →	OM 473.907	D	<b>568</b>
2646 LK	07.2015 →	OM 470.913	D	<b>341</b>	2652 LS	05.2013 →	OM 473.907	D	<b>568</b>
2646 LK	07.2015 →	OM 470.913	D	<b>341</b>	2652 LS	05.2013 →	OM 473.909	D	<b>569</b>
2646 LS	07.2015 →	OM 470.910	D	<b>341</b>	2652 LS	05.2013 →	OM 473.909	D	<b>569</b>
2646 LS	07.2015 →	OM 470.910	D	<b>341</b>	2652 S	05.2013 →	OM 473.900	D	<b>567</b>
2646 LS	07.2015 →	OM 470.910	D	<b>341</b>	2652 S	05.2013 →	OM 473.907	D	<b>568</b>
2646 LS	07.2015 →	OM 470.913	D	<b>341</b>	2652 S	05.2013 →	OM 473.909	D	<b>569</b>
2646 LS	07.2015 →	OM 470.913	D	<b>341</b>	2653	07.2015 →	OM 471.922	D	<b>557</b>

				Pos					Pos
2653	07.2015 →	OM 471.926	D	<b>558</b>	2663 LK	05.2013 →	OM 473.907	D	<b>568</b>
2653 K	07.2015 →	OM 471.922	D	<b>557</b>	2663 LK	05.2013 →	OM 473.907	D	<b>568</b>
2653 K	07.2015 →	OM 471.926	D	<b>558</b>	2663 LK	05.2013 →	OM 473.909	D	<b>569</b>
2653 L	07.2015 →	OM 471.922	D	<b>557</b>	2663 LK	05.2013 →	OM 473.909	D	<b>569</b>
2653 L	07.2015 →	OM 471.922	D	<b>557</b>	2663 LS	05.2013 →	OM 473.900	D	<b>567</b>
2653 L	07.2015 →	OM 471.922	D	<b>557</b>	2663 LS	05.2013 →	OM 473.900	D	<b>567</b>
2653 L	07.2015 →	OM 471.926	D	<b>558</b>	2663 LS	05.2013 →	OM 473.900	D	<b>567</b>
2653 L	07.2015 →	OM 471.926	D	<b>558</b>	2663 LS	05.2013 →	OM 473.907	D	<b>568</b>
2653 L	07.2015 →	OM 471.926	D	<b>558</b>	2663 LS	05.2013 →	OM 473.907	D	<b>568</b>
2653 LK	07.2015 →	OM 471.922	D	<b>557</b>	2663 LS	05.2013 →	OM 473.909	D	<b>569</b>
2653 LK	07.2015 →	OM 471.922	D	<b>557</b>	2663 LS	05.2013 →	OM 473.909	D	<b>569</b>
2653 LK	07.2015 →	OM 471.926	D	<b>558</b>	2663 S	05.2013 →	OM 473.900	D	<b>567</b>
2653 LK	07.2015 →	OM 471.926	D	<b>558</b>	2663 S	05.2013 →	OM 473.907	D	<b>568</b>
2653 LS	07.2015 →	OM 471.922	D	<b>557</b>	2663 S	05.2013 →	OM 473.909	D	<b>569</b>
2653 LS	07.2015 →	OM 471.922	D	<b>557</b>	3224	05.2013 →	OM 936.912	D	<b>316</b>
2653 LS	07.2015 →	OM 471.922	D	<b>557</b>	3224 K	05.2013 →	OM 936.912	D	<b>316</b>
2653 LS	07.2015 →	OM 471.926	D	<b>558</b>	3224 L	05.2013 →	OM 936.912	D	<b>316</b>
2653 LS	07.2015 →	OM 471.926	D	<b>558</b>	3224 LK	05.2013 →	OM 936.912	D	<b>316</b>
2653 LS	07.2015 →	OM 471.926	D	<b>558</b>	3227 K	05.2013 →	OM 936.912	D	<b>316</b>
2653 S	07.2015 →	OM 471.922	D	<b>557</b>	3227 K, 3227 LK	01.2013 →	OM 936.912	D	<b>316</b>
2653 S	07.2015 →	OM 471.926	D	<b>558</b>	3227 L	01.2013 →	OM 936.912	D	<b>316</b>
2658	05.2013 →	OM 473.900	D	<b>567</b>	3227 LK	01.2013 →	OM 936.912	D	<b>316</b>
2658	05.2013 →	OM 473.907	D	<b>568</b>	3227, 3227 L	01.2013 →	OM 936.912	D	<b>316</b>
2658	05.2013 →	OM 473.909	D	<b>569</b>	3230 K, 3230 LK	01.2013 →	OM 936.912	D	<b>316</b>
2658 K	05.2013 →	OM 473.900	D	<b>567</b>	3230 L	01.2013 →	OM 936.912	D	<b>316</b>
2658 K	05.2013 →	OM 473.907	D	<b>568</b>	3230 LK	01.2013 →	OM 936.912	D	<b>316</b>
2658 K	05.2013 →	OM 473.909	D	<b>569</b>	3230, 3230 L	01.2013 →	OM 936.912	D	<b>316</b>
2658 L	05.2013 →	OM 473.900	D	<b>567</b>	3232 K, 3232 LK	01.2013 →	OM 936.912	D	<b>316</b>
2658 L	05.2013 →	OM 473.900	D	<b>567</b>	3232 L	01.2013 →	OM 936.916	D	<b>316</b>
2658 L	05.2013 →	OM 473.900	D	<b>567</b>	3232 L	03.2016 →	OM 936.916	D	<b>316</b>
2658 L	05.2013 →	OM 473.907	D	<b>568</b>	3232 LK	01.2013 →	OM 936.916	D	<b>316</b>
2658 L	05.2013 →	OM 473.907	D	<b>568</b>	3232, 3232 L	01.2013 →	OM 936.916	D	<b>316</b>
2658 L	05.2013 →	OM 473.907	D	<b>568</b>	3233 K, 3233 LK	01.2013 →	OM 470.906	D	<b>341</b>
2658 L	05.2013 →	OM 473.909	D	<b>569</b>	3233 L	01.2013 →	OM 470.906	D	<b>341</b>
2658 L	05.2013 →	OM 473.909	D	<b>569</b>	3233 L	03.2016 →	OM 470.906	D	<b>341</b>
2658 L	05.2013 →	OM 473.909	D	<b>569</b>	3233 L	03.2016 →	OM 470.913	D	<b>341</b>
2658 LK	05.2013 →	OM 473.900	D	<b>567</b>	3233 LK	01.2013 →	OM 470.906	D	<b>341</b>
2658 LK	05.2013 →	OM 473.900	D	<b>567</b>	3233, 3233 L	01.2013 →	OM 470.906	D	<b>341</b>
2658 LK	05.2013 →	OM 473.907	D	<b>568</b>	3235 K, 3235 LK	01.2013 →	OM 936.916	D	<b>316</b>
2658 LK	05.2013 →	OM 473.907	D	<b>568</b>	3235 L	01.2013 →	OM 936.916	D	<b>316</b>
2658 LK	05.2013 →	OM 473.909	D	<b>569</b>	3235 L	03.2016 →	OM 936.916	D	<b>316</b>
2658 LK	05.2013 →	OM 473.909	D	<b>569</b>	3235 LK	01.2013 →	OM 936.916	D	<b>316</b>
2658 LS	05.2013 →	OM 473.900	D	<b>567</b>	3235, 3235 L	01.2013 →	OM 936.916	D	<b>316</b>
2658 LS	05.2013 →	OM 473.900	D	<b>567</b>	3236 K, 3236 LK	01.2013 →	OM 470.906	D	<b>341</b>
2658 LS	05.2013 →	OM 473.900	D	<b>567</b>	3236 L	01.2013 →	OM 470.906	D	<b>341</b>
2658 LS	05.2013 →	OM 473.907	D	<b>568</b>	3236 L	03.2016 →	OM 470.906	D	<b>341</b>
2658 LS	05.2013 →	OM 473.907	D	<b>568</b>	3236 L	03.2016 →	OM 470.913	D	<b>341</b>
2658 LS	05.2013 →	OM 473.909	D	<b>569</b>	3236 LK	01.2013 →	OM 470.906	D	<b>341</b>
2658 LS	05.2013 →	OM 473.909	D	<b>569</b>	3236, 3236 L	01.2013 →	OM 470.906	D	<b>341</b>
2658 S	05.2013 →	OM 473.900	D	<b>567</b>	3240 K, 3240 LK	01.2013 →	OM 470.906	D	<b>341</b>
2658 S	05.2013 →	OM 473.907	D	<b>568</b>	3240 L	01.2013 →	OM 470.906	D	<b>341</b>
2658 S	05.2013 →	OM 473.909	D	<b>569</b>	3240 L	03.2016 →	OM 470.906	D	<b>341</b>
2663	05.2013 →	OM 473.900	D	<b>567</b>	3240 L	03.2016 →	OM 470.913	D	<b>341</b>
2663	05.2013 →	OM 473.907	D	<b>568</b>	3240 LK	01.2013 →	OM 470.906	D	<b>341</b>
2663	05.2013 →	OM 473.909	D	<b>569</b>	3240, 3240 L	01.2013 →	OM 470.906	D	<b>341</b>
2663 K	05.2013 →	OM 473.900	D	<b>567</b>	3242 K, 3242 LK	01.2013 →	OM 471.900	D	<b>556</b>
2663 K	05.2013 →	OM 473.907	D	<b>568</b>	3242 L	01.2013 →	OM 471.900	D	<b>556</b>
2663 K	05.2013 →	OM 473.909	D	<b>569</b>	3242 L	03.2016 →	OM 471.900	D	<b>556</b>
2663 L	05.2013 →	OM 473.900	D	<b>567</b>	3242 L	03.2016 →	OM 471.926	D	<b>558</b>
2663 L	05.2013 →	OM 473.900	D	<b>567</b>	3242 LK	01.2013 →	OM 471.900	D	<b>556</b>
2663 L	05.2013 →	OM 473.900	D	<b>567</b>	3242, 3242 L	01.2013 →	OM 471.900	D	<b>556</b>
2663 L	05.2013 →	OM 473.907	D	<b>568</b>	3243 K, 3243 LK	01.2013 →	OM 470.906	D	<b>341</b>
2663 L	05.2013 →	OM 473.907	D	<b>568</b>	3243 L	01.2013 →	OM 470.906	D	<b>341</b>
2663 L	05.2013 →	OM 473.907	D	<b>568</b>	3243 L	03.2016 →	OM 470.906	D	<b>341</b>
2663 L	05.2013 →	OM 473.909	D	<b>569</b>	3243 L	03.2016 →	OM 470.913	D	<b>341</b>
2663 L	05.2013 →	OM 473.909	D	<b>569</b>	3243 LK	01.2013 →	OM 470.906	D	<b>341</b>
2663 L	05.2013 →	OM 473.909	D	<b>569</b>	3243, 3243 L	01.2013 →	OM 470.906	D	<b>341</b>
2663 LK	05.2013 →	OM 473.900	D	<b>567</b>	3245 K, 3245 LK	01.2013 →	OM 471.900	D	<b>556</b>
2663 LK	05.2013 →	OM 473.900	D	<b>567</b>	3245 L	01.2013 →	OM 471.900	D	<b>556</b>

M



		Pos			Pos		
3245 L	03.2016 →	OM 471.900 D	<b>556</b>	3263 L	05.2013 →	OM 473.907 D	<b>568</b>
3245 L	03.2016 →	OM 471.926 D	<b>558</b>	3263 L	05.2013 →	OM 473.909 D	<b>569</b>
3245 LK	01.2013 →	OM 471.900 D	<b>556</b>	3263 LK	05.2013 →	OM 473.900 D	<b>567</b>
3245, 3245 L	01.2013 →	OM 471.900 D	<b>556</b>	3263 LK	05.2013 →	OM 473.907 D	<b>568</b>
3246	07.2015 →	OM 470.910 D	<b>341</b>	3263 LK	05.2013 →	OM 473.909 D	<b>569</b>
3246	07.2015 →	OM 470.913 D	<b>341</b>	3332 K	05.2013 →	OM 936.916 D	<b>316</b>
3246 K	07.2015 →	OM 470.910 D	<b>341</b>	3333 A	01.2013 →	OM 470.906 D	<b>341</b>
3246 K	07.2015 →	OM 470.913 D	<b>341</b>	3333 AK	01.2013 →	OM 470.906 D	<b>341</b>
3246 L	07.2015 →	OM 470.910 D	<b>341</b>	3333 AS	01.2013 →	OM 470.906 D	<b>341</b>
3246 L	07.2015 →	OM 470.913 D	<b>341</b>	3333 K, 3333 LK	01.2013 →	OM 470.906 D	<b>341</b>
3246 L	03.2016 →	OM 470.913 D	<b>341</b>	3333 L	05.2013 →	OM 470.906 D	<b>341</b>
3246 LK	07.2015 →	OM 470.910 D	<b>341</b>	3333 L	05.2013 →	OM 470.910 D	<b>341</b>
3246 LK	07.2015 →	OM 470.913 D	<b>341</b>	3333 L	05.2013 →	OM 470.913 D	<b>341</b>
3248 K, 3248 LK	01.2013 →	OM 471.900 D	<b>556</b>	3333 LK	05.2013 →	OM 470.906 D	<b>341</b>
3248 K, 3248 LK	01.2013 →	OM 471.926 D	<b>558</b>	3333 LK	05.2013 →	OM 470.910 D	<b>341</b>
3248 L	01.2013 →	OM 471.900 D	<b>556</b>	3333 LK	05.2013 →	OM 470.913 D	<b>341</b>
3248 L	01.2013 →	OM 471.926 D	<b>558</b>	3333 LS	05.2013 →	OM 470.906 D	<b>341</b>
3248 L	03.2016 →	OM 471.900 D	<b>556</b>	3333 LS	05.2013 →	OM 470.910 D	<b>341</b>
3248 L	03.2016 →	OM 471.926 D	<b>558</b>	3333 LS	05.2013 →	OM 470.913 D	<b>341</b>
3248 LK	01.2013 →	OM 471.900 D	<b>556</b>	3333 S, 3333 LS	01.2013 →	OM 470.906 D	<b>341</b>
3248 LK	01.2013 →	OM 471.926 D	<b>558</b>	3333, 3333 L	01.2013 →	OM 470.906 D	<b>341</b>
3248, 3248 L	01.2013 →	OM 471.900 D	<b>556</b>	3335 K	05.2013 →	OM 936.916 D	<b>316</b>
3248, 3248 L	01.2013 →	OM 471.926 D	<b>558</b>	3336 A	01.2013 →	OM 470.903 D	<b>341</b>
3251 K, 3251 LK	01.2013 →	OM 471.909 D	<b>556</b>	3336 AK	01.2013 →	OM 470.903 D	<b>341</b>
3251 L	01.2013 →	OM 471.909 D	<b>556</b>	3336 AS	01.2013 →	OM 470.903 D	<b>341</b>
3251 L	03.2016 →	OM 471.900 D	<b>556</b>	3336 K, 3336 LK	01.2013 →	OM 470.906 D	<b>341</b>
3251 L	03.2016 →	OM 471.926 D	<b>558</b>	3336 L	05.2013 →	OM 470.906 D	<b>341</b>
3251 LK	01.2013 →	OM 471.909 D	<b>556</b>	3336 L	05.2013 →	OM 470.910 D	<b>341</b>
3251, 3251 L	01.2013 →	OM 471.909 D	<b>556</b>	3336 L	05.2013 →	OM 470.913 D	<b>341</b>
3252	05.2013 →	OM 473.900 D	<b>567</b>	3336 LK	05.2013 →	OM 470.906 D	<b>341</b>
3252	05.2013 →	OM 473.907 D	<b>568</b>	3336 LK	05.2013 →	OM 470.910 D	<b>341</b>
3252	05.2013 →	OM 473.909 D	<b>569</b>	3336 LK	05.2013 →	OM 470.913 D	<b>341</b>
3252 K	05.2013 →	OM 473.900 D	<b>567</b>	3336 LS	05.2013 →	OM 470.906 D	<b>341</b>
3252 K	05.2013 →	OM 473.907 D	<b>568</b>	3336 LS	05.2013 →	OM 470.910 D	<b>341</b>
3252 K	05.2013 →	OM 473.909 D	<b>569</b>	3336 LS	05.2013 →	OM 470.913 D	<b>341</b>
3252 L	05.2013 →	OM 473.900 D	<b>567</b>	3336 S, 3336 LS	01.2013 →	OM 470.906 D	<b>341</b>
3252 L	05.2013 →	OM 473.907 D	<b>568</b>	3336, 3336 L	01.2013 →	OM 470.906 D	<b>341</b>
3252 L	05.2013 →	OM 473.909 D	<b>569</b>	3340 A	01.2013 →	OM 470.906 D	<b>341</b>
3252 LK	05.2013 →	OM 473.900 D	<b>567</b>	3340 AK	01.2013 →	OM 470.906 D	<b>341</b>
3252 LK	05.2013 →	OM 473.907 D	<b>568</b>	3340 AS	01.2013 →	OM 470.906 D	<b>341</b>
3252 LK	05.2013 →	OM 473.909 D	<b>569</b>	3340 K, 3340 LK	01.2013 →	OM 470.906 D	<b>341</b>
3253	07.2015 →	OM 471.922 D	<b>557</b>	3340 L	05.2013 →	OM 470.906 D	<b>341</b>
3253	07.2015 →	OM 471.926 D	<b>558</b>	3340 L	05.2013 →	OM 470.910 D	<b>341</b>
3253 K	07.2015 →	OM 471.922 D	<b>557</b>	3340 L	05.2013 →	OM 470.913 D	<b>341</b>
3253 K	07.2015 →	OM 471.926 D	<b>558</b>	3340 LK	05.2013 →	OM 470.906 D	<b>341</b>
3253 L	07.2015 →	OM 471.922 D	<b>557</b>	3340 LK	05.2013 →	OM 470.910 D	<b>341</b>
3253 L	07.2015 →	OM 471.926 D	<b>558</b>	3340 LK	05.2013 →	OM 470.913 D	<b>341</b>
3253 L	03.2016 →	OM 471.926 D	<b>558</b>	3340 LS	05.2013 →	OM 470.906 D	<b>341</b>
3253 LK	07.2015 →	OM 471.922 D	<b>557</b>	3340 LS	05.2013 →	OM 470.910 D	<b>341</b>
3253 LK	07.2015 →	OM 471.926 D	<b>558</b>	3340 LS	05.2013 →	OM 470.913 D	<b>341</b>
3258	05.2013 →	OM 473.900 D	<b>567</b>	3340 S, 3340 LS	01.2013 →	OM 470.906 D	<b>341</b>
3258	05.2013 →	OM 473.907 D	<b>568</b>	3340, 3340 L	01.2013 →	OM 470.906 D	<b>341</b>
3258	05.2013 →	OM 473.909 D	<b>569</b>	3342 A	01.2013 →	OM 471.900 D	<b>556</b>
3258 K	05.2013 →	OM 473.900 D	<b>567</b>	3342 AK	01.2013 →	OM 471.900 D	<b>556</b>
3258 K	05.2013 →	OM 473.907 D	<b>568</b>	3342 AS	01.2013 →	OM 471.900 D	<b>556</b>
3258 K	05.2013 →	OM 473.909 D	<b>569</b>	3342 K, 3342 LK	01.2013 →	OM 471.900 D	<b>556</b>
3258 L	05.2013 →	OM 473.900 D	<b>567</b>	3342 L	05.2013 →	OM 471.900 D	<b>556</b>
3258 L	05.2013 →	OM 473.907 D	<b>568</b>	3342 L	05.2013 →	OM 471.922 D	<b>557</b>
3258 L	05.2013 →	OM 473.909 D	<b>569</b>	3342 L	05.2013 →	OM 471.926 D	<b>558</b>
3258 LK	05.2013 →	OM 473.900 D	<b>567</b>	3342 LK	05.2013 →	OM 471.900 D	<b>556</b>
3258 LK	05.2013 →	OM 473.907 D	<b>568</b>	3342 LK	05.2013 →	OM 471.922 D	<b>557</b>
3258 LK	05.2013 →	OM 473.909 D	<b>569</b>	3342 LK	05.2013 →	OM 471.926 D	<b>558</b>
3263	05.2013 →	OM 473.900 D	<b>567</b>	3342 LS	05.2013 →	OM 471.900 D	<b>556</b>
3263	05.2013 →	OM 473.907 D	<b>568</b>	3342 LS	05.2013 →	OM 471.922 D	<b>557</b>
3263	05.2013 →	OM 473.909 D	<b>569</b>	3342 LS	05.2013 →	OM 471.926 D	<b>558</b>
3263 K	05.2013 →	OM 473.900 D	<b>567</b>	3342 S, 3342 LS	01.2013 →	OM 471.900 D	<b>556</b>
3263 K	05.2013 →	OM 473.907 D	<b>568</b>	3342, 3342 L	01.2013 →	OM 471.900 D	<b>556</b>
3263 K	05.2013 →	OM 473.909 D	<b>569</b>	3343 A	01.2013 →	OM 470.906 D	<b>341</b>
3263 L	05.2013 →	OM 473.900 D	<b>567</b>	3343 AK	01.2013 →	OM 470.906 D	<b>341</b>

			Pos				Pos
3343 AS	01.2013 →	OM 470.906	D 341	3348 S, 3348 LS	01.2013 →	OM 471.900	D 556
3343 K, 3343 LK	01.2013 →	OM 470.906	D 341	3348, 3348 L	01.2013 →	OM 471.900	D 556
3343 L	05.2013 →	OM 470.906	D 341	3351 A	01.2013 →	OM 471.909	D 556
3343 L	05.2013 →	OM 470.910	D 341	3351 AK	01.2013 →	OM 471.909	D 556
3343 L	05.2013 →	OM 470.913	D 341	3351 AS	01.2013 →	OM 471.909	D 556
3343 LK	05.2013 →	OM 470.906	D 341	3351 K, 3351 LK	01.2013 →	OM 471.909	D 556
3343 LK	05.2013 →	OM 470.910	D 341	3351 L	05.2013 →	OM 471.900	D 556
3343 LK	05.2013 →	OM 470.913	D 341	3351 L	05.2013 →	OM 471.922	D 557
3343 LS	05.2013 →	OM 470.906	D 341	3351 L	05.2013 →	OM 471.926	D 558
3343 LS	05.2013 →	OM 470.910	D 341	3351 LK	05.2013 →	OM 471.900	D 556
3343 LS	05.2013 →	OM 470.913	D 341	3351 LK	05.2013 →	OM 471.922	D 557
3343 S, 3343 LS	01.2013 →	OM 470.906	D 341	3351 LK	05.2013 →	OM 471.926	D 558
3343, 3343 L	01.2013 →	OM 470.906	D 341	3351 LS	05.2013 →	OM 471.900	D 556
3345 A	01.2013 →	OM 471.906	D 556	3351 LS	05.2013 →	OM 471.922	D 557
3345 A	01.2013 →	OM 471.926	D 558	3351 LS	05.2013 →	OM 471.926	D 558
3345 AK	01.2013 →	OM 471.906	D 556	3351 S, 3351 LS	01.2013 →	OM 471.909	D 556
3345 AK	01.2013 →	OM 471.926	D 558	3351, 3351 L	01.2013 →	OM 471.909	D 556
3345 AS	01.2013 →	OM 471.906	D 556	3352	05.2013 →	OM 473.900	D 567
3345 AS	01.2013 →	OM 471.926	D 558	3352	05.2013 →	OM 473.907	D 568
3345 L	05.2013 →	OM 471.900	D 556	3352	05.2013 →	OM 473.909	D 569
3345 L	05.2013 →	OM 471.922	D 557	3352 A	05.2013 →	OM 473.903	D 567
3345 L	05.2013 →	OM 471.926	D 558	3352 A	05.2013 →	OM 473.907	D 568
3345 LK	05.2013 →	OM 471.900	D 556	3352 A	05.2013 →	OM 473.909	D 569
3345 LK	05.2013 →	OM 471.922	D 557	3352 AK	05.2013 →	OM 473.903	D 567
3345 LK	05.2013 →	OM 471.926	D 558	3352 AK	05.2013 →	OM 473.907	D 568
3345 LS	05.2013 →	OM 471.900	D 556	3352 AK	05.2013 →	OM 473.909	D 569
3345 LS	05.2013 →	OM 471.922	D 557	3352 AS	05.2013 →	OM 473.903	D 567
3345 LS	05.2013 →	OM 471.926	D 558	3352 AS	05.2013 →	OM 473.907	D 568
3345, 3345 L	01.2013 →	OM 471.900	D 556	3352 AS	05.2013 →	OM 473.909	D 569
3345K, 3345 LK	01.2013 →	OM 471.900	D 556	3352 K	05.2013 →	OM 473.900	D 567
3345S, 3345 LS	01.2013 →	OM 471.900	D 556	3352 K	05.2013 →	OM 473.907	D 568
3346	07.2015 →	OM 470.910	D 341	3352 K	05.2013 →	OM 473.909	D 569
3346	07.2015 →	OM 470.913	D 341	3352 L	05.2013 →	OM 473.900	D 567
3346 A	07.2015 →	OM 470.910	D 341	3352 L	05.2013 →	OM 473.900	D 567
3346 A	07.2015 →	OM 470.913	D 341	3352 L	05.2013 →	OM 473.907	D 568
3346 AK	07.2015 →	OM 470.910	D 341	3352 L	05.2013 →	OM 473.907	D 568
3346 AK	07.2015 →	OM 470.913	D 341	3352 L	05.2013 →	OM 473.909	D 569
3346 AS	07.2015 →	OM 470.910	D 341	3352 L	05.2013 →	OM 473.909	D 569
3346 AS	07.2015 →	OM 470.913	D 341	3352 LK	05.2013 →	OM 473.900	D 567
3346 K	07.2015 →	OM 470.910	D 341	3352 LK	05.2013 →	OM 473.900	D 567
3346 K	07.2015 →	OM 470.913	D 341	3352 LK	05.2013 →	OM 473.907	D 568
3346 L	07.2015 →	OM 470.910	D 341	3352 LK	05.2013 →	OM 473.907	D 568
3346 L	07.2015 →	OM 470.910	D 341	3352 LK	05.2013 →	OM 473.909	D 569
3346 L	07.2015 →	OM 470.913	D 341	3352 LK	05.2013 →	OM 473.909	D 569
3346 L	07.2015 →	OM 470.913	D 341	3352 LS	05.2013 →	OM 473.900	D 567
3346 LK	07.2015 →	OM 470.910	D 341	3352 LS	05.2013 →	OM 473.900	D 567
3346 LK	07.2015 →	OM 470.910	D 341	3352 LS	05.2013 →	OM 473.907	D 568
3346 LK	07.2015 →	OM 470.913	D 341	3352 LS	05.2013 →	OM 473.907	D 568
3346 LK	07.2015 →	OM 470.913	D 341	3352 LS	05.2013 →	OM 473.909	D 569
3346 LS	07.2015 →	OM 470.910	D 341	3352 LS	05.2013 →	OM 473.909	D 569
3346 LS	07.2015 →	OM 470.910	D 341	3352 S	05.2013 →	OM 473.900	D 567
3346 LS	07.2015 →	OM 470.913	D 341	3352 S	05.2013 →	OM 473.907	D 568
3346 LS	07.2015 →	OM 470.913	D 341	3352 S	05.2013 →	OM 473.909	D 569
3346 S	07.2015 →	OM 470.910	D 341	3352 SLT	12.2013 →	OM 473.900	D 567
3346 S	07.2015 →	OM 470.913	D 341	3352 SLT	04.2014 →	OM 473.903	D 567
3348 A	01.2013 →	OM 471.906	D 556	3353	07.2015 →	OM 471.922	D 557
3348 A	01.2013 →	OM 471.926	D 558	3353	07.2015 →	OM 471.926	D 558
3348 AK	01.2013 →	OM 471.906	D 556	3353 A	07.2015 →	OM 471.922	D 557
3348 AS	01.2013 →	OM 471.906	D 556	3353 A	07.2015 →	OM 471.926	D 558
3348 K, 3348 LK	01.2013 →	OM 471.900	D 556	3353 AK	07.2015 →	OM 471.922	D 557
3348 L	05.2013 →	OM 471.900	D 556	3353 AK	07.2015 →	OM 471.926	D 558
3348 L	05.2013 →	OM 471.922	D 557	3353 AS	07.2015 →	OM 471.922	D 557
3348 L	05.2013 →	OM 471.926	D 558	3353 AS	07.2015 →	OM 471.926	D 558
3348 LK	05.2013 →	OM 471.900	D 556	3353 K	07.2015 →	OM 471.922	D 557
3348 LK	05.2013 →	OM 471.922	D 557	3353 K	07.2015 →	OM 471.926	D 558
3348 LK	05.2013 →	OM 471.926	D 558	3353 L	07.2015 →	OM 471.922	D 557
3348 LS	05.2013 →	OM 471.900	D 556	3353 L	07.2015 →	OM 471.922	D 557
3348 LS	05.2013 →	OM 471.922	D 557	3353 L	07.2015 →	OM 471.926	D 558
3348 LS	05.2013 →	OM 471.926	D 558	3353 L	07.2015 →	OM 471.926	D 558

M

		Pos			Pos
3353 LK 07.2015 →	OM 471.922 D	557	3363 LK 05.2013 →	OM 473.900 D	567
3353 LK 07.2015 →	OM 471.922 D	557	3363 LK 05.2013 →	OM 473.900 D	567
3353 LK 07.2015 →	OM 471.926 D	558	3363 LK 05.2013 →	OM 473.907 D	568
3353 LK 07.2015 →	OM 471.926 D	558	3363 LK 05.2013 →	OM 473.907 D	568
3353 LS 07.2015 →	OM 471.922 D	557	3363 LK 05.2013 →	OM 473.909 D	569
3353 LS 07.2015 →	OM 471.922 D	557	3363 LK 05.2013 →	OM 473.909 D	569
3353 LS 07.2015 →	OM 471.926 D	558	3363 LS 05.2013 →	OM 473.900 D	567
3353 LS 07.2015 →	OM 471.926 D	558	3363 LS 05.2013 →	OM 473.900 D	567
3353 S 07.2015 →	OM 471.922 D	557	3363 LS 05.2013 →	OM 473.907 D	568
3353 S 07.2015 →	OM 471.926 D	558	3363 LS 05.2013 →	OM 473.907 D	568
3358 05.2013 →	OM 473.900 D	567	3363 LS 05.2013 →	OM 473.909 D	569
3358 05.2013 →	OM 473.907 D	568	3363 LS 05.2013 →	OM 473.909 D	569
3358 05.2013 →	OM 473.909 D	569	3363 S 05.2013 →	OM 473.900 D	567
3358 A 05.2013 →	OM 473.903 D	567	3363 S 05.2013 →	OM 473.907 D	568
3358 A 05.2013 →	OM 473.907 D	568	3363 S 05.2013 →	OM 473.909 D	569
3358 A 05.2013 →	OM 473.909 D	569	3363 SLT 12.2013 →	OM 473.900 D	567
3358 AK 05.2013 →	OM 473.903 D	567	3363 SLT 04.2014 →	OM 473.903 D	567
3358 AK 05.2013 →	OM 473.907 D	568	4052 SLT 12.2013 →	OM 473.900 D	567
3358 AK 05.2013 →	OM 473.909 D	569	4052 SLT 04.2014 →	OM 473.903 D	567
3358 AS 05.2013 →	OM 473.903 D	567	4058 SLT 12.2013 →	OM 473.900 D	567
3358 AS 05.2013 →	OM 473.907 D	568	4058 SLT 04.2014 →	OM 473.903 D	567
3358 AS 05.2013 →	OM 473.909 D	569	4063 SLT 12.2013 →	OM 473.900 D	567
3358 K 05.2013 →	OM 473.900 D	567	4063 SLT 04.2014 →	OM 473.903 D	567
3358 K 05.2013 →	OM 473.907 D	568	4133 01.2013 →	OM 470.906 D	341
3358 K 05.2013 →	OM 473.909 D	569	4133 AK 01.2013 →	OM 470.903 D	341
3358 L 05.2013 →	OM 473.900 D	567	4133 AK 01.2013 →	OM 470.903 D	341
3358 L 05.2013 →	OM 473.900 D	567	4133 K 01.2013 →	OM 470.906 D	341
3358 L 05.2013 →	OM 473.907 D	568	4136 01.2013 →	OM 470.906 D	341
3358 L 05.2013 →	OM 473.907 D	568	4136 AK 01.2013 →	OM 470.903 D	341
3358 L 05.2013 →	OM 473.909 D	569	4136 AK 01.2013 →	OM 470.903 D	341
3358 L 05.2013 →	OM 473.909 D	569	4140 01.2013 →	OM 470.906 D	341
3358 LK 05.2013 →	OM 473.900 D	567	4140 AK 01.2013 →	OM 470.903 D	341
3358 LK 05.2013 →	OM 473.900 D	567	4140 AK 01.2013 →	OM 470.903 D	341
3358 LK 05.2013 →	OM 473.907 D	568	4140 K 01.2013 →	OM 470.906 D	341
3358 LK 05.2013 →	OM 473.907 D	568	4142 01.2013 →	OM 471.900 D	556
3358 LK 05.2013 →	OM 473.909 D	569	4142 AK 01.2013 →	OM 471.906 D	556
3358 LK 05.2013 →	OM 473.909 D	569	4142 AK 01.2013 →	OM 471.906 D	556
3358 LS 05.2013 →	OM 473.900 D	567	4142 K 01.2013 →	OM 471.900 D	556
3358 LS 05.2013 →	OM 473.900 D	567	4143 01.2013 →	OM 470.906 D	341
3358 LS 05.2013 →	OM 473.907 D	568	4143 AK 01.2013 →	OM 470.903 D	341
3358 LS 05.2013 →	OM 473.907 D	568	4143 AK 01.2013 →	OM 470.903 D	341
3358 LS 05.2013 →	OM 473.909 D	569	4143 K 01.2013 →	OM 470.906 D	341
3358 LS 05.2013 →	OM 473.909 D	569	4145 01.2013 →	OM 471.900 D	556
3358 S 05.2013 →	OM 473.900 D	567	4145 AK 01.2013 →	OM 471.906 D	556
3358 S 05.2013 →	OM 473.907 D	568	4145 AK 01.2013 →	OM 471.906 D	556
3358 S 05.2013 →	OM 473.909 D	569	4145 K 01.2013 →	OM 471.900 D	556
3358 SLT 12.2013 →	OM 473.900 D	567	4146 07.2015 →	OM 470.910 D	341
3358 SLT 04.2014 →	OM 473.903 D	567	4146 07.2015 →	OM 470.913 D	341
3363 05.2013 →	OM 473.900 D	567	4146 AK 07.2015 →	OM 470.910 D	341
3363 05.2013 →	OM 473.907 D	568	4146 AK 07.2015 →	OM 470.910 D	341
3363 05.2013 →	OM 473.909 D	569	4146 AK 07.2015 →	OM 470.913 D	341
3363 A 05.2013 →	OM 473.903 D	567	4146 AK 07.2015 →	OM 470.913 D	341
3363 A 05.2013 →	OM 473.907 D	568	4146 K 07.2015 →	OM 470.910 D	341
3363 A 05.2013 →	OM 473.909 D	569	4146 K 07.2015 →	OM 470.913 D	341
3363 AK 05.2013 →	OM 473.903 D	567	4148 01.2013 →	OM 471.900 D	556
3363 AK 05.2013 →	OM 473.907 D	568	4148 AK 01.2013 →	OM 471.906 D	556
3363 AK 05.2013 →	OM 473.909 D	569	4148 AK 01.2013 →	OM 471.906 D	556
3363 AS 05.2013 →	OM 473.903 D	567	4148 K 01.2013 →	OM 471.900 D	556
3363 AS 05.2013 →	OM 473.907 D	568	4151 01.2013 →	OM 471.909 D	556
3363 AS 05.2013 →	OM 473.909 D	569	4151 AK 01.2013 →	OM 471.906 D	556
3363 K 05.2013 →	OM 473.900 D	567	4151 AK 01.2013 →	OM 471.906 D	556
3363 K 05.2013 →	OM 473.907 D	568	4151 K 01.2013 →	OM 471.909 D	556
3363 K 05.2013 →	OM 473.909 D	569	4152 05.2013 →	OM 473.900 D	567
3363 L 05.2013 →	OM 473.900 D	567	4152 05.2013 →	OM 473.907 D	568
3363 L 05.2013 →	OM 473.900 D	567	4152 05.2013 →	OM 473.909 D	569
3363 L 05.2013 →	OM 473.907 D	568	4152 AK 05.2013 →	OM 473.903 D	567
3363 L 05.2013 →	OM 473.907 D	568	4152 AK 05.2013 →	OM 473.907 D	568
3363 L 05.2013 →	OM 473.909 D	569	4152 AK 05.2013 →	OM 473.909 D	569
3363 L 05.2013 →	OM 473.909 D	569	4152 AK 07.2015 →	OM 473.907 D	568



				Pos					Pos
4152 AK	07.2015 →	OM 473.909	D	569	1214 K	01.1998 → 10.2004	OM 904.910	D	242
4152 K	05.2013 →	OM 473.900	D	567	1214 K	01.1998 → 10.2004	OM 904.916	D	242
4152 K	05.2013 →	OM 473.907	D	568	1214, 1214 L	01.1998 → 09.2004	OM 904.910	D	242
4152 K	05.2013 →	OM 473.909	D	569	1214, 1214 L	01.1998 → 10.2004	OM 904.916	D	242
4152 SLT	12.2013 →	OM 473.900	D	567	1215 K	01.1998 → 10.2004	OM 904.922	D	244
4152 SLT	04.2014 →	OM 473.903	D	567	1215, 1215 L	01.1998 → 09.2004	OM 904.922	D	244
4152 SLT	04.2014 →	OM 473.903	D	567	1217 K	01.1998 → 10.2004	OM 904.911	D	242
4153	07.2015 →	OM 471.922	D	557	1217 K	01.1998 → 10.2004	OM 904.917	D	242
4153	07.2015 →	OM 471.926	D	558	1217, 1217 L	01.1998 → 10.2004	OM 904.911	D	242
4153 AK	07.2015 →	OM 471.922	D	557	1217, 1217 L	01.1998 → 10.2004	OM 904.917	D	242
4153 AK	07.2015 →	OM 471.922	D	557	1218		OM 904.976	D	242
4153 AK	07.2015 →	OM 471.926	D	558	1218		OM 904.978	D	273
4153 AK	07.2015 →	OM 471.926	D	558	1222 Blue Tec	06.2006 →	OM 924.922	D	290
4153 K	07.2015 →	OM 471.922	D	557	1223 K	01.1998 → 09.2004	OM 906.910	D	253
4153 K	07.2015 →	OM 471.926	D	558	1223 K	01.1998 → 09.2004	OM 906.915	D	245
4158	05.2013 →	OM 473.900	D	567	1223, 1223 L	01.1998 → 10.2004	OM 906.910	D	253
4158	05.2013 →	OM 473.907	D	568	1223, 1223 L	01.1998 → 10.2004	OM 906.915	D	245
4158	05.2013 →	OM 473.909	D	569	1228, 1228 L	01.1998 → 10.2004	OM 906.911	D	252
4158 AK	05.2013 →	OM 473.903	D	567	1228, 1228 L	01.1998 → 10.2004	OM 906.916	D	245
4158 AK	05.2013 →	OM 473.907	D	568	1317 A	01.1998 → 10.2004	OM 904.911	D	242
4158 AK	05.2013 →	OM 473.909	D	569	1317 A	01.1998 → 10.2004	OM 904.917	D	242
4158 AK	07.2015 →	OM 473.907	D	568	1317 AK	01.1998 → 10.2004	OM 900.913	D	249
4158 AK	07.2015 →	OM 473.909	D	569	1317 AK	01.1998 → 10.2004	OM 904.911	D	242
4158 K	05.2013 →	OM 473.900	D	567	1317 AK	01.1998 → 10.2004	OM 904.917	D	242
4158 K	05.2013 →	OM 473.907	D	568	1317 K	01.1998 → 10.2004	OM 904.911	D	242
4158 K	05.2013 →	OM 473.909	D	569	1317 K	01.1998 → 10.2004	OM 904.917	D	242
4158 SLT	12.2013 →	OM 473.900	D	567	1317, 1317 L	01.1998 → 09.2004	OM 904.911	D	242
4158 SLT	04.2014 →	OM 473.903	D	567	1317, 1317 L	01.1998 → 10.2004	OM 904.917	D	242
4158 SLT	04.2014 →	OM 473.903	D	567	1318		OM 904.911	D	242
4163	05.2013 →	OM 473.900	D	567	1318		OM 904.967	D	242
4163	05.2013 →	OM 473.907	D	568	1318		OM 904.972	D	242
4163	05.2013 →	OM 473.909	D	569	1318		OM 904.973	D	242
4163 AK	05.2013 →	OM 473.903	D	567	1318		OM 904.976	D	242
4163 AK	05.2013 →	OM 473.907	D	568	1318		OM 904.980	D	242
4163 AK	05.2013 →	OM 473.909	D	569	1322 Blue Tec	06.2006 →	OM 924.922	D	290
4163 AK	07.2015 →	OM 473.907	D	568	1323 AK	01.1998 → 09.2004	OM 906.910	D	253
4163 AK	07.2015 →	OM 473.909	D	569	1323 AK	01.1998 → 09.2004	OM 906.915	D	245
4163 K	05.2013 →	OM 473.900	D	567	1323 K	01.1998 → 09.2004	OM 906.910	D	253
4163 K	05.2013 →	OM 473.907	D	568	1323 K	01.1998 → 09.2004	OM 906.915	D	245
4163 K	05.2013 →	OM 473.909	D	569	1323 LS	01.1998 → 10.2004	OM 906.910	D	253
4163 SLT	12.2013 →	OM 473.900	D	567	1323, 1323 L	01.1998 → 10.2004	OM 906.910	D	253
4163 SLT	04.2014 →	OM 473.903	D	567	1323, 1323 L	01.1998 → 10.2004	OM 906.915	D	245
4163 SLT	04.2014 →	OM 473.903	D	567	1328 LS	01.1998 → 10.2004	OM 906.911	D	252
4452 SLT	04.2014 →	OM 473.903	D	567	1328, 1328 L	01.1998 → 10.2004	OM 906.911	D	252
4458 SLT	04.2014 →	OM 473.903	D	567	1328, 1328 L	01.1998 → 10.2004	OM 906.916	D	245
4463 SLT	04.2014 →	OM 473.903	D	567	1517 A	01.1998 → 10.2004	OM 904.911	D	242
4845 K	01.2018 →	OM 471.900	D	556	1517 A	01.1998 → 10.2004	OM 904.917	D	242
4852 SLT	04.2014 →	OM 473.903	D	567	1517 AK	01.1998 → 10.2004	OM 904.911	D	242
4858 SLT	04.2014 →	OM 473.903	D	567	1517 AK	01.1998 → 10.2004	OM 904.917	D	242
4863 SLT	04.2014 →	OM 473.903	D	567	1517 K	01.1998 → 10.2004	OM 904.911	D	242
<b>ATEGO</b>					1517, 1517 L	01.1998 → 09.2004	OM 904.911	D	242
1014 K	01.1998 → 10.2004	OM 904.916	D	242	1517, 1517 L	01.1998 → 10.2004	OM 904.917	D	242
1014, 1014 L	01.1998 → 10.2004	OM 904.916	D	242	1518	01.1998 →	OM 904.911	D	242
1017 A	01.1998 → 10.2004	OM 904.911	D	242	1518	01.1998 →	OM 904.967	D	242
1017 A	01.1998 → 10.2004	OM 904.917	D	242	1518	01.1998 →	OM 904.972	D	242
1017 AK	01.1998 → 10.2004	OM 904.911	D	242	1518	01.1998 →	OM 904.973	D	242
1017 K	01.1998 → 10.2004	OM 904.911	D	242	1518	01.1998 →	OM 904.976	D	242
1017 K	01.1998 → 10.2004	OM 904.917	D	242	1518	01.1998 →	OM 904.980	D	242
1017, 1017 L	01.1998 → 09.2004	OM 904.911	D	242	1522 Blue Tec	06.2006 →	OM 924.922	D	290
1017, 1017 L	01.1998 → 10.2004	OM 904.917	D	242	1523 A	01.1998 → 10.2004	OM 906.910	D	253
1022 BlueTec	06.2006 →	OM 924.922	D	290	1523 A	01.1998 → 10.2004	OM 906.915	D	245
1022 BlueTec	06.2006 →	OM 924.930	D	294	1523 AK	01.1998 → 10.2004	OM 906.910	D	253
1023 AK	01.1998 → 10.2004	OM 906.910	D	253	1523 AK	01.1998 → 10.2004	OM 906.915	D	245
1023 AK	01.1998 → 10.2004	OM 906.915	D	245	1523 K	01.1998 → 10.2004	OM 906.910	D	253
1023 K	01.1998 → 10.2004	OM 906.910	D	253	1523 K	01.1998 → 10.2004	OM 906.915	D	245
1023 K	01.1998 → 10.2004	OM 906.915	D	245	1523, 1523 L	01.1998 → 10.2004	OM 906.910	D	253
1023, 1023 L	01.1998 → 10.2004	OM 906.910	D	253	1523, 1523 L	01.1998 → 10.2004	OM 906.915	D	245
1115		OM 904.977	D	273	1528 AK	01.1998 → 09.2004	OM 906.911	D	252
1115		OM 904.978	D	273	1528 AK	01.1998 → 09.2004	OM 906.916	D	245

M

			Pos				Pos
1528 K	01.1998 → 09.2004	OM 906.911	D 252	814 K	01.1998 → 10.2004	OM 904.916	D 242
1528 K	01.1998 → 09.2004	OM 906.916	D 245	814, 814 L	01.1998 → 09.2004	OM 904.910	D 242
1528, 1528 L	01.1998 → 10.2004	OM 906.911	D 252	814, 814 L	01.1998 → 10.2004	OM 904.916	D 242
1528, 1528 L	01.1998 → 10.2004	OM 906.916	D 245	814, 814 L	01.1998 → 10.2004	OM 904.930	D 244
1634		OM 457.914	D 441	815 K	01.1998 → 10.2004	OM 904.922	D 244
1718		OM 904.911	D 242	815 K	01.1998 → 10.2004	OM 904.922	D 244
1718		OM 904.967	D 242	815, 815 L	01.1998 → 10.2004	OM 904.922	D 244
1718		OM 904.972	D 242	815,815 L	01.1998 → 09.2004	OM 904.922	D 244
1718		OM 904.973	D 242	817 K	01.1998 → 10.2004	OM 904.911	D 242
1718		OM 904.976	D 242	817 K	01.1998 → 10.2004	OM 904.911	D 242
1718		OM 904.980	D 242	817 K	01.1998 → 10.2004	OM 904.917	D 242
1723		OM 924.924	D 293	817, 817 L	01.1998 → 09.2004	OM 904.911	D 242
1725	01.2000 →	OM 906.983	D 259	817, 817 L	01.1998 → 10.2004	OM 904.911	D 242
1725	01.2000 →	OM 906.985	D 241	817, 817 L	01.1998 → 10.2004	OM 904.917	D 242
1726		OM 906.985	D 241	817, 817 L	01.1998 → 10.2004	OM 904.917	D 242
1728	01.1998 →	OM 906.918	D 241	822 Blue Tec	06.2006 →	OM 924.922	D 290
1728	01.1998 →	OM 906.953	D 241	823 K	01.1998 → 10.2004	OM 906.910	D 253
1728	01.1998 →	OM 906.956	D 251	823 K	01.1998 → 10.2004	OM 906.915	D 245
1823 AK	04.1998 → 10.2004	OM 906.922	D 245	823, 823 L	01.1998 → 10.2004	OM 906.910	D 253
1823 K	04.1998 → 10.2004	OM 906.920	D 245	823, 823 L	01.1998 → 10.2004	OM 906.915	D 245
1823 LS	04.1998 → 10.2004	OM 906.920	D 245	914 K	01.1998 → 10.2004	OM 904.916	D 242
1823, 1823 L	01.1998 → 10.2004	OM 906.920	D 245	914, 914 L	01.1998 → 10.2004	OM 904.916	D 242
1823, 1823 L	01.1998 → 10.2004	OM 906.925	D 245	916 Blue Tec	02.2006 →	OM 900.912	D 249
1826		OM 902.914	D 251	916 Blue Tec	01.2010 →	OM 934.911	D 317
1828 A	04.1998 → 10.2004	OM 906.923	D 245	917 K	01.1998 → 10.2004	OM 904.911	D 242
1828 AK	04.1998 → 10.2004	OM 906.923	D 245	917 K	01.1998 → 10.2004	OM 904.917	D 242
1828 K	04.1998 → 10.2004	OM 906.921	D 245	917, 917 L	01.1998 → 09.2004	OM 904.911	D 242
1828 LS	04.1998 → 10.2004	OM 906.921	D 245	917, 917 L	01.1998 → 10.2004	OM 904.917	D 242
1828, 1828 L	04.1998 → 10.2004	OM 906.921	D 245	922 Blue Tec	06.2006 →	OM 924.922	D 290
1828, 1828 L	04.1998 → 10.2004	OM 906.926	D 245	923 K	01.1998 → 10.2004	OM 906.910	D 253
1923 L	04.1998 → 10.2004	OM 906.910	D 253	923 K	01.1998 → 10.2004	OM 906.915	D 245
1923 L	04.1998 → 10.2004	OM 906.915	D 245	923, 923 L	01.1998 → 10.2004	OM 906.910	D 253
1928 L	04.1998 → 10.2004	OM 906.911	D 252	<b>ATEGO 2</b>			
1928 L	04.1998 → 10.2004	OM 906.916	D 245	1015 K	10.2004 →	OM 904.916	D 242
2124 Blue Tec	02.2006 →	OM 902.916	D 251	1015 K, 1016 K	10.2004 →	OM 900.912	D 249
2223 L	04.1998 → 10.2004	OM 906.910	D 253	1015 K, 1016 K	10.2004 →	OM 900.918	D 249
2223 L	04.1998 → 10.2004	OM 906.915	D 245	1015 K, 1016 K	10.2004 →	OM 904.922	D 244
2228 L	04.1998 → 10.2004	OM 906.911	D 252	1015, 1015 L	10.2004 →	OM 904.922	D 244
2228 L	04.1998 → 10.2004	OM 906.916	D 245	1016, 1016 L	10.2004 →	OM 900.918	D 249
2423		OM 906.924	D 241	1016, 1016 L	10.2004 →	OM 924.935	D 284
2523 L	04.1998 → 10.2004	OM 906.920	D 245	1016, 1016 L	02.2006 →	OM 900.912	D 249
2528 L	04.1998 → 10.2004	OM 906.921	D 245	1017 AK	10.2004 →	OM 904.917	D 242
2528 L	04.1998 → 10.2004	OM 906.921	D 245	1017 K, 1018 K	10.2004 →	OM 900.913	D 249
2528 L	04.1998 → 10.2004	OM 906.926	D 245	1017 K, 1018 K	10.2004 →	OM 900.919	D 249
2528 L	04.1998 → 10.2004	OM 906.926	D 245	1017 K, 1018 K	10.2004 →	OM 904.911	D 242
2529		OM 902.914	D 251	1018 A	10.2004 →	OM 900.913	D 249
2623	01.1998 →	OM 906.925	D 245	1018 A	10.2004 →	OM 900.919	D 249
2623	05.1998 →	OM 906.920	D 245	1018 AK	10.2004 →	OM 900.913	D 249
2628	04.1998 → 10.2004	OM 906.921	D 245	1018, 1018 L	10.2004 →	OM 900.919	D 249
2628 K	04.1998 → 10.2004	OM 906.921	D 245	1018, 1018 L	02.2006 →	OM 900.913	D 249
3028	01.1998 →	OM 906.926	D 245	1022 A	10.2004 →	OM 924.922	D 290
3028	05.1998 →	OM 906.921	D 245	1022 AK	10.2004 →	OM 924.922	D 290
3228	01.1998 →	OM 906.926	D 245	1022 K	10.2004 →	OM 924.920	D 290
3228	05.1998 →	OM 906.921	D 245	1022 K	10.2004 →	OM 924.922	D 290
712	01.1998 → 09.2004	OM 904.909	D 242	1022, 1022 L	10.2004 →	OM 924.920	D 290
714 K	01.1998 → 10.2004	OM 904.910	D 242	1022, 1022 L	10.2004 →	OM 924.922	D 290
714 K	01.1998 → 10.2004	OM 904.916	D 242	1022, 1022 L	10.2004 →	OM 924.930	D 294
714, 714 L	01.1998 → 09.2004	OM 904.910	D 242	1023 A, 1024 A	10.2004 →	OM 902.916	D 251
714, 714 L	01.1998 → 10.2004	OM 904.916	D 242	1023 A, 1024 A	10.2004 →	OM 906.910	D 253
715,715 L	01.1998 → 09.2004	OM 904.922	D 244	1023 A, 1024 A	10.2004 →	OM 906.915	D 245
717 K	01.1998 → 10.2004	OM 904.911	D 242	1023, 1023 L, 1024, 1024 L	10.2004 →	OM 902.916	D 251
717 K	01.1998 → 10.2004	OM 904.917	D 242	L			
717, 717 L	01.1998 → 09.2004	OM 904.911	D 242	1023, 1023 L, 1024, 1024 L	10.2004 →	OM 906.910	D 253
717, 717 L	01.1998 → 10.2004	OM 904.917	D 242	L			
722 BlueTec	06.2006 →	OM 924.930	D 294	1023, 1023 L, 1024, 1024 L	10.2004 →	OM 906.915	D 245
812	01.1998 → 09.2004	OM 904.909	D 242	L			
814 K	01.1998 → 10.2004	OM 904.910	D 242	1024 AK	10.2004 →	OM 902.916	D 251
814 K	01.1998 → 10.2004	OM 904.910	D 242	1024 K	10.2004 →	OM 902.916	D 251
814 K	01.1998 → 10.2004	OM 904.916	D 242	1024, 1024 L	10.2004 →	OM 925.920	D 284



		Pos			Pos
1026, 1026 L 10.2004 →	OM 925.920 D	284	1328 LS, 1329 LS 10.2004 →	OM 906.916 D	245
1029, 1029 L 10.2004 →	OM 925.920 D	284	1328, 1328 L, 1329, 1329 L 10.2004 →	OM 902.918 D	252
1215, 1215 L, 1216, 1216 L 10.2004 →	OM 904.922 D	244	1328, 1328 L, 1329, 1329 L 10.2004 →	OM 906.911 D	252
1215, 1215 L, 1216, 1216 L 02.2006 →	OM 900.912 D	249	1328, 1328 L, 1329, 1329 L 10.2004 →	OM 906.916 D	245
1216 K 10.2004 →	OM 900.912 D	249	1329, 1329 L 10.2004 →	OM 925.920 D	284
1216, 1216 L 10.2004 →	OM 924.935 D	284	1418 10.2004 →	OM 904.967 D	242
1218 K 10.2004 →	OM 900.913 D	249	1418 01.2011 →	OM 900.913 D	249
1218, 1218 L 02.2006 →	OM 900.913 D	249	1418 K 01.2011 →	OM 904.962 D	240
1222 K 10.2004 →	OM 924.920 D	290	1418 K 01.2011 →	OM 904.967 D	242
1222 K 10.2004 →	OM 924.922 D	290	1418 K 01.2011 →	OM 904.968 D	240
1222, 1222 L 10.2004 →	OM 924.920 D	290	1418 K 01.2011 →	OM 904.972 D	242
1222, 1222 L 10.2004 →	OM 924.922 D	290	1418 K 01.2011 →	OM 904.973 D	242
1222, 1222 L 06.2006 →	OM 924.930 D	294	1418 K 01.2011 →	OM 904.976 D	242
1223, 1223 L, 1224, 1224 L 10.2004 →	OM 902.916 D	251	1419 10.2004 →	OM 924.989 D	287
1223, 1223 L, 1224, 1224 L 10.2004 →	OM 906.910 D	253	1518 A 10.2004 →	OM 900.913 D	249
1223, 1223 L, 1224, 1224 L 10.2004 →	OM 906.915 D	245	1518 AK 10.2004 →	OM 900.913 D	249
1224 K 10.2004 →	OM 902.916 D	251	1518 K 10.2004 →	OM 900.913 D	249
1224, 1224 L 10.2004 →	OM 925.920 D	284	1518, 1518 L 10.2004 →	OM 904.962 D	240
1226, 1226 L 10.2004 → 12.2014	OM 925.920 D	284	1518, 1518 L 10.2004 →	OM 904.967 D	242
1226, 1226 L 10.2004 →	OM 902.917 D	252	1518, 1518 L 10.2004 →	OM 904.968 D	240
1228, 1228 L, 1229, 1229 L 10.2004 →	OM 902.918 D	252	1518, 1518 L 10.2004 →	OM 904.972 D	242
1228, 1228 L, 1229, 1229 L 10.2004 →	OM 906.911 D	252	1518, 1518 L 10.2004 →	OM 904.976 D	242
1228, 1228 L, 1229, 1229 L 10.2004 →	OM 906.916 D	245	1518, 1518 L 02.2006 →	OM 900.913 D	249
1229, 1229 L 10.2004 →	OM 925.920 D	284	1522 A 10.2004 →	OM 924.922 D	290
1315 10.2004 →	OM 904.957 D	240	1522 AK 10.2004 →	OM 924.922 D	290
1315 10.2004 →	OM 904.965 D	264	1522 K 10.2004 →	OM 924.920 D	290
1315 10.2004 →	OM 904.966 D	240	1522 K 10.2004 →	OM 924.922 D	290
1315 10.2004 →	OM 904.970 D	240	1522, 1522 L 10.2004 →	OM 924.920 D	290
1318 A 10.2004 →	OM 900.913 D	249	1522, 1522 L 06.2006 →	OM 924.930 D	294
1318 A 10.2004 →	OM 904.949 D	244	1523 A, 1524 A 10.2004 →	OM 902.916 D	251
1318 AK 10.2004 →	OM 900.913 D	249	1523 A, 1524 A 10.2004 →	OM 906.910 D	253
1318 K 10.2004 →	OM 900.913 D	249	1523 A, 1524 A 10.2004 →	OM 906.915 D	245
1318, 1318 L 02.2006 →	OM 900.913 D	249	1523 K, 1524 K 10.2004 →	OM 902.916 D	251
1322 A 10.2004 →	OM 924.922 D	290	1523, 1523 L, 1524, 1524 L 10.2004 →	OM 902.916 D	251
1322 AK 10.2004 →	OM 924.922 D	290	1523, 1523 L, 1524, 1524 L 10.2004 →	OM 906.910 D	253
1322 K 10.2004 →	OM 924.920 D	290	1523, 1523 L, 1524, 1524 L 10.2004 →	OM 906.915 D	245
1322 K 10.2004 →	OM 924.922 D	290	1524 AK 10.2004 →	OM 902.916 D	251
1322 LS 10.2004 →	OM 924.920 D	290	1524, 1524 L 10.2004 →	OM 925.920 D	284
1322 LS 10.2004 →	OM 924.922 D	290	1526 AK 10.2004 →	OM 902.917 D	252
1322, 1322 L 10.2004 →	OM 924.920 D	290	1526 K 10.2004 →	OM 902.917 D	252
1322, 1322 L 10.2004 →	OM 924.922 D	290	1526, 1526 L 10.2004 →	OM 902.917 D	252
1322, 1322 L 06.2006 →	OM 924.930 D	294	1526, 1526 L 10.2004 →	OM 925.920 D	284
1323 A, 1324 A 10.2004 →	OM 902.916 D	251	1528, 1528 L, 1529, 1529 L 10.2004 →	OM 902.918 D	252
1323 A, 1324 A 10.2004 →	OM 906.910 D	253	1528, 1528 L, 1529, 1529 L 10.2004 →	OM 906.911 D	252
1323 A, 1324 A 10.2004 →	OM 906.915 D	245	1528, 1528 L, 1529, 1529 L 10.2004 →	OM 906.916 D	245
1323 LS, 1324 LS 10.2004 →	OM 902.916 D	251	1529 AK 10.2004 →	OM 902.918 D	252
1323 LS, 1324 LS 10.2004 →	OM 906.910 D	253	1529 K 10.2004 →	OM 902.918 D	252
1323 LS, 1324 LS 10.2004 →	OM 906.915 D	245	1529, 1529 L 10.2004 →	OM 925.920 D	284
1323, 1323 L, 1324, 1324 L 10.2004 →	OM 902.916 D	251	1618 10.2004 →	OM 900.913 D	249
1323, 1323 L, 1324, 1324 L 10.2004 →	OM 906.910 D	253	1618 K 10.2004 →	OM 900.913 D	249
1323, 1323 L, 1324, 1324 L 10.2004 →	OM 906.915 D	245	1622 10.2004 →	OM 924.920 D	290
1324 AK 10.2004 →	OM 902.916 D	251	1622 10.2004 →	OM 924.922 D	290
1324 K 10.2004 →	OM 902.916 D	251	1622 10.2004 →	OM 924.930 D	294
1324, 1324 L 10.2004 →	OM 925.920 D	284	1622 K 10.2004 →	OM 924.920 D	290
1326 LS 10.2004 →	OM 902.917 D	252	1622 K 10.2004 →	OM 924.922 D	290
1326, 1326 L 10.2004 →	OM 902.917 D	252	1622 K 10.2004 →	OM 924.930 D	294
1326, 1326 L 10.2004 →	OM 925.920 D	284	1624 10.2004 →	OM 902.916 D	251
1328 LS, 1329 LS 10.2004 →	OM 902.918 D	252	1624 K 10.2004 →	OM 902.916 D	251
1328 LS, 1329 LS 10.2004 →	OM 906.911 D	252	1629 10.2004 →	OM 902.918 D	252
			1718 10.2004 →	OM 904.962 D	240

M

				Pos					Pos
1718	10.2004 →	OM 904.967	D	242	816, 816 L	10.2004 →	OM 900.912	D	249
1718	10.2004 →	OM 904.968	D	240	816, 816 L	10.2004 →	OM 924.935	D	284
1718	10.2004 →	OM 904.972	D	242	818 K	02.2006 →	OM 900.913	D	249
1718	10.2004 →	OM 904.973	D	242	818 K	02.2006 →	OM 900.913	D	249
1718	10.2004 →	OM 904.976	D	242	818 K	02.2006 →	OM 900.919	D	249
1718	01.2011 →	OM 900.913	D	249	818 K	02.2006 →	OM 900.919	D	249
1718 K	01.2011 →	OM 904.962	D	240	818, 818 L	02.2006 →	OM 900.913	D	249
1718 K	01.2011 →	OM 904.967	D	242	818, 818 L	02.2006 →	OM 900.913	D	249
1718 K	01.2011 →	OM 904.968	D	240	818, 818 L	02.2006 →	OM 900.919	D	249
1718 K	01.2011 →	OM 904.972	D	242	818, 818 L	02.2006 →	OM 900.919	D	249
1718 K	01.2011 →	OM 904.973	D	242	822 K	10.2004 →	OM 924.920	D	290
1718 K	01.2011 →	OM 904.976	D	242	822 K	10.2004 →	OM 924.920	D	290
1719	10.2004 →	OM 924.989	D	287	822 K	10.2004 →	OM 924.922	D	290
1722	10.2004 →	OM 924.924	D	293	822, 822 L	10.2004 →	OM 924.920	D	290
1725	10.2004 →	OM 906.985	D	241	822, 822 L	10.2004 →	OM 924.920	D	290
1725	01.2011 →	OM 906.919	D	245	822, 822 L	10.2004 →	OM 924.922	D	290
1725	01.2011 →	OM 906.983	D	259	822, 822 L	10.2004 →	OM 924.922	D	290
1725	01.2011 →	OM 906.988	D	241	822, 822 L	10.2004 →	OM 924.930	D	294
1725	01.2011 →	OM 906.990	D	266	822, 822 L	06.2006 →	OM 924.930	D	294
1725 A	10.2006 →	OM 906.985	D	241	823, 823 L, 824, 824 L	10.2004 →	OM 902.916	D	251
1725 A	01.2011 →	OM 906.919	D	245	823, 823 L, 824, 824 L	10.2004 →	OM 906.910	D	253
1725 A	01.2011 →	OM 906.983	D	259	823, 823 L, 824, 824 L	10.2004 →	OM 906.915	D	245
1725 A	01.2011 →	OM 906.988	D	241	824 K	10.2004 →	OM 902.916	D	251
1725 A	01.2011 →	OM 906.990	D	266	824, 824 L	10.2004 →	OM 925.920	D	284
1725 S	01.2007 →	OM 906.985	D	241	826, 826 L	10.2004 →	OM 925.920	D	284
1728 S	01.2007 →	OM 906.986	D	265	829, 829 L	10.2004 →	OM 925.920	D	284
1728 S	01.2007 →	OM 926.941	D	282	915 K	10.2004 →	OM 904.922	D	244
1924 L	10.2004 →	OM 902.916	D	251	915, 915 L, 916, 916 L	10.2004 →	OM 904.922	D	244
1924 L	10.2004 →	OM 902.916	D	251	915, 915 L, 916, 916 L	02.2006 →	OM 900.912	D	249
1926 L	10.2004 →	OM 902.917	D	252	915, 915 L, 916, 916 L	02.2006 →	OM 900.918	D	249
1926 L	10.2004 →	OM 902.917	D	252	916 K	02.2006 →	OM 900.912	D	249
1929 L	10.2004 →	OM 902.918	D	252	916 K	02.2006 →	OM 900.918	D	249
1929 L	10.2004 →	OM 902.918	D	252	916, 916 L	10.2004 →	OM 924.935	D	284
2224 L	10.2004 →	OM 902.916	D	251	918 K	10.2004 →	OM 900.913	D	249
2224 L	10.2004 →	OM 902.916	D	251	918 K	02.2006 →	OM 900.919	D	249
2226 L	10.2004 →	OM 902.917	D	252	918, 918 L	02.2006 →	OM 900.913	D	249
2226 L	10.2004 →	OM 902.917	D	252	918, 918 L	02.2006 →	OM 900.919	D	249
2229 L	10.2004 →	OM 902.918	D	252	922 K	10.2004 →	OM 924.920	D	290
2229 L	10.2004 →	OM 902.918	D	252	922 K	10.2004 →	OM 924.922	D	290
2422	10.2004 →	OM 924.924	D	293	922, 922 L	10.2004 →	OM 924.920	D	290
2425	10.2004 →	OM 906.985	D	241	922, 922 L	10.2004 →	OM 924.922	D	290
2425	01.2011 →	OM 906.919	D	245	922, 922 L	06.2006 →	OM 924.930	D	294
2425	01.2011 →	OM 906.983	D	259	923, 923 L, 924, 924 L	10.2004 →	OM 902.916	D	251
2425	01.2011 →	OM 906.988	D	241	923, 923 L, 924, 924 L	10.2004 →	OM 906.910	D	253
2425	01.2011 →	OM 906.990	D	266	923, 923 L, 924, 924 L	10.2004 →	OM 906.915	D	245
2428	10.2004 →	OM 906.986	D	265	924 K	10.2004 →	OM 902.916	D	251
2428	10.2004 →	OM 926.941	D	282	924, 924 L	10.2004 →	OM 925.920	D	284
2428	01.2011 →	OM 906.921	D	245	926, 926 L	10.2004 →	OM 925.920	D	284
2529 L	10.2004 →	OM 902.915	D	251	929, 929 L	10.2004 →	OM 925.920	D	284
712, 713	10.2004 →	OM 900.911	D	249	<b>ATEGO 3</b>				
712, 713	10.2004 →	OM 904.909	D	242	1016 A	05.2013 →	OM 934.911	D	317
712, 713	10.2004 →	OM 904.915	D	242	1016 AK	05.2013 →	OM 934.911	D	317
712, 713	02.2006 →	OM 900.917	D	249	1016 K	04.2013 →	OM 934.911	D	317
715, 715 L, 716, 716 L	10.2004 →	OM 904.922	D	244	1016, 1016 L	04.2013 →	OM 934.911	D	317
715, 715 L, 716, 716 L	02.2006 →	OM 900.912	D	249	1018 A	04.2013 →	OM 934.911	D	317
715, 715 L, 716, 716 L	02.2006 →	OM 900.918	D	249	1018 AK	04.2013 →	OM 934.911	D	317
812 K	10.2004 →	OM 904.909	D	242	1018 K	04.2013 →	OM 934.911	D	317
812, 813	10.2004 →	OM 904.909	D	242	1018, 1018 L	04.2013 →	OM 934.911	D	317
812, 813	02.2006 →	OM 900.911	D	249	1021 A	04.2013 →	OM 934.913	D	317
812, 813	02.2006 →	OM 900.917	D	249	1021 AK	04.2013 →	OM 934.913	D	317
815 K, 816 K	10.2004 →	OM 904.922	D	244	1021 K	04.2013 →	OM 934.913	D	317
815 K, 816 K	10.2004 →	OM 904.922	D	244	1021, 1021 L	04.2013 →	OM 934.913	D	317
815 K, 816 K	02.2006 →	OM 900.912	D	249	1023 A	04.2013 →	OM 934.913	D	317
815 K, 816 K	02.2006 →	OM 900.912	D	249	1023 AK	04.2013 →	OM 934.913	D	317
815 K, 816 K	02.2006 →	OM 900.918	D	249	1023 K	04.2013 →	OM 934.913	D	317
815 K, 816 K	02.2006 →	OM 900.918	D	249	1023, 1023 L	04.2013 →	OM 934.913	D	317
815, 815 L, 816, 816 L	10.2004 →	OM 904.922	D	244	1024 A	04.2013 →	OM 936.910	D	316
815, 815 L, 816, 816 L	02.2006 →	OM 900.912	D	249	1024 AK	04.2013 →	OM 936.910	D	316
815, 815 L, 816, 816 L	02.2006 →	OM 900.918	D	249	1024 K	04.2013 →	OM 936.910	D	316

		Pos			Pos		
1024, 1024 L	04.2013 →	OM 936.910 D	<b>316</b>	1516 K	05.2013 →	OM 934.911 D	<b>317</b>
1027	05.2013 →	OM 936.910 D	<b>316</b>	1518 A	04.2013 →	OM 934.911 D	<b>317</b>
1027 A	05.2013 →	OM 936.910 D	<b>316</b>	1518 K	04.2013 →	OM 934.911 D	<b>317</b>
1027 AK	05.2013 →	OM 936.910 D	<b>316</b>	1518, 1518 L	04.2013 →	OM 934.911 D	<b>317</b>
1027 K	05.2013 →	OM 936.910 D	<b>316</b>	1521 A	04.2013 →	OM 934.913 D	<b>317</b>
1027 L	05.2013 →	OM 936.910 D	<b>316</b>	1521 AK	04.2013 →	OM 934.913 D	<b>317</b>
1030	05.2013 →	OM 936.910 D	<b>316</b>	1521 K	04.2013 →	OM 934.913 D	<b>317</b>
1030 A	05.2013 →	OM 936.910 D	<b>316</b>	1521, 1521 L	04.2013 →	OM 934.913 D	<b>317</b>
1030 AK	05.2013 →	OM 936.910 D	<b>316</b>	1523 A	04.2013 →	OM 934.913 D	<b>317</b>
1030 K	05.2013 →	OM 936.910 D	<b>316</b>	1523 AK	04.2013 →	OM 934.913 D	<b>317</b>
1030 L	05.2013 →	OM 936.910 D	<b>316</b>	1523 K	04.2013 →	OM 934.913 D	<b>317</b>
1216 K	04.2013 →	OM 934.911 D	<b>317</b>	1523, 1523 L	04.2013 →	OM 934.913 D	<b>317</b>
1216, 1216 L	04.2013 →	OM 934.911 D	<b>317</b>	1524 A	04.2013 →	OM 936.910 D	<b>316</b>
1216, 1216 L	04.2013 →	OM 934.911 D	<b>317</b>	1524 AK	04.2013 →	OM 936.910 D	<b>316</b>
1218 K	04.2013 →	OM 934.911 D	<b>317</b>	1524 K	04.2013 →	OM 936.910 D	<b>316</b>
1218, 1218 L	04.2013 →	OM 934.911 D	<b>317</b>	1524, 1524 L	04.2013 →	OM 936.910 D	<b>316</b>
1218, 1218 L	04.2013 →	OM 934.911 D	<b>317</b>	1527 A	05.2013 →	OM 936.910 D	<b>316</b>
1221 K	04.2013 →	OM 934.913 D	<b>317</b>	1527 AK	04.2013 →	OM 936.910 D	<b>316</b>
1221, 1221 L	04.2013 →	OM 934.913 D	<b>317</b>	1527 K	04.2013 →	OM 936.910 D	<b>316</b>
1221, 1221 L	04.2013 →	OM 934.913 D	<b>317</b>	1527, 1527 L	04.2013 →	OM 936.910 D	<b>316</b>
1223 K	04.2013 →	OM 934.913 D	<b>317</b>	1530 A	05.2013 →	OM 936.910 D	<b>316</b>
1223, 1223 L	04.2013 →	OM 934.913 D	<b>317</b>	1530 AK	04.2013 →	OM 936.910 D	<b>316</b>
1223, 1223 L	04.2013 →	OM 934.913 D	<b>317</b>	1530 K	04.2013 →	OM 936.910 D	<b>316</b>
1224 K	04.2013 →	OM 936.910 D	<b>316</b>	1530, 1530 L	04.2013 →	OM 936.910 D	<b>316</b>
1224, 1224 L	04.2013 →	OM 936.910 D	<b>316</b>	1720	08.2016 → 03.2019	OM 924.930 D	<b>294</b>
1224, 1224 L	04.2013 →	OM 936.910 D	<b>316</b>	2124	04.2017 →	OM 936.910 D	<b>316</b>
1227 K	04.2013 →	OM 936.910 D	<b>316</b>	2127	04.2017 →	OM 936.910 D	<b>316</b>
1227, 1227 L	04.2013 →	OM 936.910 D	<b>316</b>	2130	04.2017 →	OM 936.910 D	<b>316</b>
1227, 1227 L	04.2013 →	OM 936.910 D	<b>316</b>	716 K	04.2013 →	OM 934.911 D	<b>317</b>
1230 K	04.2013 →	OM 936.910 D	<b>316</b>	716, 716 L	04.2013 →	OM 934.911 D	<b>317</b>
1230, 1230 L	04.2013 →	OM 936.910 D	<b>316</b>	716, 716 L	04.2013 →	OM 934.911 D	<b>317</b>
1230, 1230 L	04.2013 →	OM 936.910 D	<b>316</b>	718 K	04.2013 →	OM 934.911 D	<b>317</b>
1316	05.2013 →	OM 934.911 D	<b>317</b>	718, 718 L	04.2013 →	OM 934.911 D	<b>317</b>
1316 A	05.2013 →	OM 934.911 D	<b>317</b>	721 K	04.2013 →	OM 934.913 D	<b>317</b>
1316 AK	05.2013 →	OM 934.911 D	<b>317</b>	721, 721 L	04.2013 →	OM 934.913 D	<b>317</b>
1316 K	05.2013 →	OM 934.911 D	<b>317</b>	723 K	04.2013 →	OM 934.913 D	<b>317</b>
1316 L	05.2013 →	OM 934.911 D	<b>317</b>	723, 723 L	04.2013 →	OM 934.913 D	<b>317</b>
1318 A	04.2013 →	OM 934.911 D	<b>317</b>	816 K	04.2013 →	OM 934.911 D	<b>317</b>
1318 AK	04.2013 →	OM 934.911 D	<b>317</b>	816 K	04.2013 →	OM 934.911 D	<b>317</b>
1318 K	04.2013 →	OM 934.911 D	<b>317</b>	816, 816 L	04.2013 →	OM 934.911 D	<b>317</b>
1318, 1318 L	04.2013 →	OM 934.911 D	<b>317</b>	816, 816 L	04.2013 →	OM 934.911 D	<b>317</b>
1321 A	04.2013 →	OM 934.913 D	<b>317</b>	818 K	04.2013 →	OM 934.911 D	<b>317</b>
1321 AK	04.2013 →	OM 934.913 D	<b>317</b>	818 K	04.2013 →	OM 934.911 D	<b>317</b>
1321 K	04.2013 →	OM 934.913 D	<b>317</b>	818, 818 L	04.2013 →	OM 934.911 D	<b>317</b>
1321 LS	04.2013 →	OM 934.913 D	<b>317</b>	818, 818 L	04.2013 →	OM 934.911 D	<b>317</b>
1321, 1321 L	04.2013 →	OM 934.913 D	<b>317</b>	821 K	04.2013 →	OM 934.913 D	<b>317</b>
1323 A	04.2013 →	OM 934.913 D	<b>317</b>	821 K	04.2013 →	OM 934.913 D	<b>317</b>
1323 AK	04.2013 →	OM 934.913 D	<b>317</b>	821, 821 L	04.2013 →	OM 934.913 D	<b>317</b>
1323 K	04.2013 →	OM 934.913 D	<b>317</b>	821, 821 L	04.2013 →	OM 934.913 D	<b>317</b>
1323 LS	04.2013 →	OM 934.913 D	<b>317</b>	823 K	04.2013 →	OM 934.913 D	<b>317</b>
1323, 1323 L	04.2013 →	OM 934.913 D	<b>317</b>	823 K	04.2013 →	OM 934.913 D	<b>317</b>
1324 A	04.2013 →	OM 936.910 D	<b>316</b>	823, 823 L	04.2013 →	OM 934.913 D	<b>317</b>
1324 AK	04.2013 →	OM 936.910 D	<b>316</b>	823, 823 L	04.2013 →	OM 934.913 D	<b>317</b>
1324 K	04.2013 →	OM 936.910 D	<b>316</b>	824 K	04.2013 →	OM 936.910 D	<b>316</b>
1324 LS	04.2013 →	OM 936.910 D	<b>316</b>	824, 824 L	04.2013 →	OM 936.910 D	<b>316</b>
1324, 1324 L	04.2013 →	OM 936.910 D	<b>316</b>	827	05.2013 →	OM 936.910 D	<b>316</b>
1327 A	05.2013 →	OM 936.910 D	<b>316</b>	827 K	05.2013 →	OM 936.910 D	<b>316</b>
1327 AK	04.2013 →	OM 936.910 D	<b>316</b>	827 L	05.2013 →	OM 936.910 D	<b>316</b>
1327 K	04.2013 →	OM 936.910 D	<b>316</b>	830	05.2013 →	OM 936.910 D	<b>316</b>
1327 LS	04.2013 →	OM 936.910 D	<b>316</b>	830 K	05.2013 →	OM 936.910 D	<b>316</b>
1327, 1327 L	04.2013 →	OM 936.910 D	<b>316</b>	830 L	05.2013 →	OM 936.910 D	<b>316</b>
1330 A	05.2013 →	OM 936.910 D	<b>316</b>	916 K	04.2013 →	OM 934.911 D	<b>317</b>
1330 AK	04.2013 →	OM 936.910 D	<b>316</b>	916, 916 L	04.2013 →	OM 934.911 D	<b>317</b>
1330 K	04.2013 →	OM 936.910 D	<b>316</b>	918 K	04.2013 →	OM 934.911 D	<b>317</b>
1330 LS	04.2013 →	OM 936.910 D	<b>316</b>	918, 918 L	04.2013 →	OM 934.911 D	<b>317</b>
1330, 1330 L	04.2013 →	OM 936.910 D	<b>316</b>	921 K	04.2013 →	OM 934.913 D	<b>317</b>
1515 L	05.2013 →	OM 934.911 D	<b>317</b>	921, 921 L	04.2013 →	OM 934.913 D	<b>317</b>
1516	05.2013 →	OM 934.911 D	<b>317</b>	923 K	04.2013 →	OM 934.913 D	<b>317</b>
1516 A	05.2013 →	OM 934.911 D	<b>317</b>	923, 923 L	04.2013 →	OM 934.913 D	<b>317</b>

M



		Pos			Pos
924 K 04.2013 →	OM 936.910 D	316	1823 K, 1823 KL, 1824 K 10.2004 →	OM 906.920 D	245
924, 924 L 04.2013 →	OM 936.910 D	316	1823 K, 1823 KL, 1824 K 10.2004 →	OM 906.925 D	245
927 05.2013 →	OM 936.910 D	316	1823 LS, 1824 LS 10.2004 →	OM 902.913 D	251
927 K 05.2013 →	OM 936.910 D	316	1823 LS, 1824 LS 10.2004 →	OM 906.920 D	245
927 L 05.2013 →	OM 936.910 D	316	1823, 1823 L, 1824, 1824 10.2004 →	OM 902.913 D	251
930 05.2013 →	OM 936.910 D	316	L, LL		
930 K 05.2013 →	OM 936.910 D	316	1823, 1823 L, 1824, 1824 10.2004 →	OM 906.920 D	245
930 L 05.2013 →	OM 936.910 D	316	L, LL		
<b>ATRON</b>			1826 AK 10.2004 →	OM 902.914 D	251
1635 S 01.2012 →	OM 457.914 D	441	1826 AK 10.2004 →	OM 902.931 D	252
1720 01.2012 → 07.2016	OM 904.932 D	242	1826 K 10.2004 →	OM 902.914 D	251
<b>AXOR</b>			1826 LS 10.2004 →	OM 902.914 D	251
1728	OM 926.941 D	282	1826, 1826 L, LL 10.2004 →	OM 902.914 D	251
1733	OM 926.935 D	288	1828 A, 1829 A 10.2004 →	OM 902.932 D	252
1733	OM 926.947 D	301	1828 A, 1829 A 10.2004 →	OM 906.923 D	245
1823 01.2002 → 10.2004	OM 906.920 D	245	1828 A, 1829 A 10.2004 →	OM 906.928 D	254
1823 K 01.2002 → 10.2004	OM 906.920 D	245	1828 AK, 1829 AK 10.2004 →	OM 902.932 D	252
1828 01.1998 →	OM 906.956 D	251	1828 AK, 1829 AK 10.2004 →	OM 906.923 D	245
1828 01.2002 →	OM 906.921 D	245	1828 AK, 1829 AK 10.2004 →	OM 906.928 D	254
1831	OM 457.955 D	446	1828 K, 1828 KL, 1829 K 10.2004 →	OM 902.915 D	251
1831	OM 457.956 D	454	1828 K, 1828 KL, 1829 K 10.2004 →	OM 906.921 D	245
1831 01.2002 →	OM 457.937 D	454	1828 K, 1828 KL, 1829 K 10.2004 →	OM 906.926 D	245
1833 Blue Tec	OM 926.934 D	292	1828 LS 10.2004 →	OM 906.921 D	245
1835 LS 01.2002 → 10.2004	OM 457.937 D	454	1828, 1828 L, 1829, 1829 10.2004 →	OM 902.915 D	251
1840 LS 01.2002 → 10.2004	OM 457.937 D	454	L, LL		
1843 LS 01.2002 → 10.2004	OM 457.937 D	454	1828, 1828 L, 1829, 1829 10.2004 →	OM 906.921 D	245
1923 01.1998 →	OM 906.910 D	253	L, LL		
1935	OM 457.956 D	454	1828, 1828 L, 1829, 1829 10.2004 →	OM 906.926 D	245
1935 01.2002 →	OM 457.937 D	454	L, LL		
1938 10.1999 →	OM 457.920 D	453	1829 LS 10.2004 →	OM 902.915 D	251
1938 10.1999 →	OM 457.923 D	453	1833 A 10.2004 →	OM 926.913 D	282
1938 10.1999 →	OM 457.928 D	440	1833 AK 10.2004 →	OM 926.913 D	282
1938 10.1999 →	OM 457.931 D	440	1833 AK 10.2004 →	OM 926.917 D	291
1944 10.1999 →	OM 457.919 D	453	1833 AK 10.2004 →	OM 926.937 D	286
1944 10.1999 →	OM 457.922 D	460	1833 K 10.2004 →	OM 926.913 D	282
2223 01.1998 →	OM 906.910 D	253	1833 K 10.2004 →	OM 926.945 D	295
2428	OM 906.953 D	241	1833 LS 10.2004 →	OM 926.913 D	282
2428	OM 926.941 D	282	1833, 1833 L, LL 10.2004 →	OM 926.913 D	282
2523 01.2002 → 10.2004	OM 906.920 D	245	1835 LS 01.2011 →	OM 457.937 D	454
2523 K 01.2002 → 10.2004	OM 906.920 D	245	1836 LS, LLS 10.2004 →	OM 457.937 D	454
2528 01.2002 → 10.2004	OM 906.921 D	245	1836 LS, LLS 10.2004 →	OM 457.948 D	448
2535 LS 01.2002 → 10.2004	OM 457.937 D	454	1836 LS, LLS 10.2004 →	OM 457.980 D	470
2535 LS 01.2002 → 10.2004	OM 457.948 D	448	1840 LS, LLS 10.2004 →	OM 457.937 D	454
2540 LS 01.2002 → 10.2004	OM 457.937 D	454	1840 LS, LLS 10.2004 →	OM 457.948 D	448
2540 LS 01.2002 → 10.2004	OM 457.948 D	448	1840 LS, LLS 10.2004 →	OM 457.955 D	446
2543 LS 01.2002 → 10.2004	OM 457.937 D	454	1840 LS, LLS 10.2004 →	OM 457.980 D	470
2543 LS 01.2002 → 10.2004	OM 457.948 D	448	1843 LS, LLS 10.2004 →	OM 457.937 D	454
2623 L 01.2002 → 10.2004	OM 906.920 D	245	1843 LS, LLS 10.2004 →	OM 457.948 D	448
2625	OM 906.990 D	266	1843 LS, LLS 10.2004 →	OM 457.980 D	470
2628 K 01.2002 → 10.2004	OM 906.921 D	245	1933 10.2004 →	OM 926.921 D	291
2628 L 01.2002 → 10.2004	OM 906.921 D	245	1933 10.2004 →	OM 926.990 D	296
2633 Blue Tec	OM 926.934 D	292	1933 S 01.2011 →	OM 926.921 D	291
2633 Blue Tec	OM 926.947 D	301	1933 S 01.2011 →	OM 926.990 D	296
2638 10.1999 →	OM 457.923 D	453	2035 S, 2036 S, LS 01.2011 →	OM 457.917 D	468
2638 10.1999 →	OM 457.924 D	440	2035 S, 2036 S, LS 01.2011 →	OM 457.918 D	469
2638 10.1999 →	OM 457.931 D	440	2040 S, 2041 S, 2041 S, 01.2011 →	OM 457.917 D	468
2825	OM 906.990 D	266	2041 LS		
3228 C 01.2002 → 10.2004	OM 906.921 D	245	2040 S, 2041 S, 2041 S, 01.2011 →	OM 457.918 D	469
3233	OM 926.934 D	292	2041 LS		
3331	OM 457.955 D	446	2044 S 01.2011 →	OM 457.917 D	468
3331	OM 457.956 D	454	2044 S 01.2011 →	OM 457.918 D	469
3331	OM 457.957 D	448	2436 LS, 2536 LS 10.2007 →	OM 457.948 D	448
3331 01.2002 →	OM 457.937 D	454	2436 LS, 2536 LS 10.2007 →	OM 457.980 D	470
<b>AXOR 2</b>			2440 LS, 2540 LS 10.2007 →	OM 457.948 D	448
1823 AK, 1824 AK 10.2004 →	OM 902.913 D	251	2440 LS, 2540 LS 10.2007 →	OM 457.981 D	450
1823 AK, 1824 AK 10.2004 →	OM 902.930 D	252	2443 LS, 2543 LS 10.2007 →	OM 457.948 D	448
1823 AK, 1824 AK 10.2004 →	OM 906.922 D	245	2443 LS, 2543 LS 10.2007 →	OM 457.980 D	470
1823 AK, 1824 AK 10.2004 →	OM 906.927 D	245	2523 01.2011 →	OM 906.920 D	245
1823 K, 1823 KL, 1824 K 10.2004 →	OM 902.913 D	251	2528 K, 2528 KL 01.2011 →	OM 906.921 D	245
			2528 L, 2529 L 10.2004 →	OM 902.915 D	251

		Pos			Pos		
2528 L, 2529 L	10.2004 →	OM 902.915 D	<b>251</b>	2831	01.2011 →	OM 926.930 D	<b>289</b>
2528 L, 2529 L	10.2004 →	OM 906.921 D	<b>245</b>	2831	01.2011 →	OM 926.932 D	<b>291</b>
2528 L, 2529 L	10.2004 →	OM 906.921 D	<b>245</b>	2831 K	01.2011 →	OM 926.930 D	<b>289</b>
2528 L, 2529 L	10.2004 →	OM 906.926 D	<b>245</b>	3028 K	01.2011 →	OM 906.921 D	<b>245</b>
2528 L, 2529 L	10.2004 →	OM 906.926 D	<b>245</b>	3131	01.2011 →	OM 926.999 D	<b>285</b>
2533, 2533 L	10.2004 →	OM 926.913 D	<b>282</b>	3131 K	01.2011 →	OM 926.999 D	<b>285</b>
2533, 2533 L	10.2004 →	OM 926.913 D	<b>282</b>	3228	01.2011 →	OM 906.921 D	<b>245</b>
2533, 2533 L	10.2004 →	OM 926.921 D	<b>291</b>	3235	10.2004 →	OM 457.937 D	<b>454</b>
2533, 2533 L	10.2004 →	OM 926.921 D	<b>291</b>	3235	10.2004 →	OM 457.948 D	<b>448</b>
2533, 2533 L	10.2004 →	OM 926.990 D	<b>296</b>	3236 K	10.2004 →	OM 457.956 D	<b>454</b>
2533, 2533 L	10.2004 →	OM 926.990 D	<b>296</b>	3236 K	10.2004 →	OM 457.957 D	<b>448</b>
2533, 2533 L	10.2008 →	OM 926.919 D	<b>292</b>	3236 K	10.2005 →	OM 457.980 D	<b>470</b>
2533, 2533 L	10.2008 →	OM 926.919 D	<b>292</b>	3236 K	10.2005 →	OM 457.981 D	<b>450</b>
2533, 2533 L	10.2008 →	OM 926.945 D	<b>295</b>	3240	03.2005 →	OM 457.937 D	<b>454</b>
2533, 2533 L	10.2008 →	OM 926.945 D	<b>295</b>	3240	03.2005 →	OM 457.948 D	<b>448</b>
2535 L, 2536 L, 2536 LL	10.2004 → 12.2004	OM 457.937 D	<b>454</b>	3240 K	10.2004 →	OM 457.956 D	<b>454</b>
2535 L, 2536 L, 2536 LL	10.2004 →	OM 457.948 D	<b>448</b>	3240 K	10.2004 →	OM 457.957 D	<b>448</b>
2535 L, 2536 L, 2536 LL	10.2004 →	OM 457.980 D	<b>470</b>	3243	10.2004 →	OM 457.937 D	<b>454</b>
2535 S, 2535 LS	10.2004 →	OM 457.918 D	<b>469</b>	3243	10.2004 →	OM 457.948 D	<b>448</b>
2535 S, 2535 LS	10.2007 →	OM 457.981 D	<b>450</b>	3243 K	10.2004 →	OM 457.956 D	<b>454</b>
2536	01.2012 →	OM 457.969 D	<b>449</b>	3243 K	10.2004 →	OM 457.957 D	<b>448</b>
2540 L, LL	10.2004 → 12.2004	OM 457.937 D	<b>454</b>	3243 K	10.2005 →	OM 457.980 D	<b>470</b>
2540 L, LL	10.2004 →	OM 457.948 D	<b>448</b>	3243 K	10.2005 →	OM 457.981 D	<b>450</b>
2540 L, LL	10.2004 →	OM 457.980 D	<b>470</b>	3335	10.2004 →	OM 457.937 D	<b>454</b>
2540 S, 2541 S, LS	10.2004 →	OM 457.918 D	<b>469</b>	3335 K	06.2009 →	OM 457.956 D	<b>454</b>
2540 S, 2541 S, LS	10.2007 →	OM 457.980 D	<b>470</b>	3335 K	06.2009 →	OM 457.957 D	<b>448</b>
2543 L, LL	10.2004 → 12.2004	OM 457.937 D	<b>454</b>	3335 S	09.2008 →	OM 457.962 D	<b>455</b>
2543 L, LL	10.2004 →	OM 457.948 D	<b>448</b>	3340 K, 3341 K	10.2004 →	OM 457.917 D	<b>468</b>
2543 L, LL	10.2004 →	OM 457.980 D	<b>470</b>	3340 K, 3341 K	10.2004 →	OM 457.918 D	<b>469</b>
2543 S, 2543 LS	10.2007 →	OM 457.980 D	<b>470</b>	3340 K, 3341 K	10.2004 →	OM 457.937 D	<b>454</b>
2544 S, 2544 LS	10.2004 →	OM 457.922 D	<b>460</b>	3340 K, 3341 K	10.2004 →	OM 457.956 D	<b>454</b>
2628 K, 2629 K	10.2004 →	OM 902.915 D	<b>251</b>	3340 K, 3341 K	10.2004 →	OM 457.957 D	<b>448</b>
2628 K, 2629 K	10.2004 →	OM 906.921 D	<b>245</b>	3340 S, 3341 S	06.2009 →	OM 457.917 D	<b>468</b>
2628 K, 2629 K	10.2004 →	OM 906.926 D	<b>245</b>	3340 S, 3341 S	06.2009 →	OM 457.918 D	<b>469</b>
2628, 2629	10.2004 →	OM 902.915 D	<b>251</b>	3340 S, 3341 S	06.2009 →	OM 457.962 D	<b>455</b>
2628, 2629	10.2004 →	OM 906.921 D	<b>245</b>	3340, 3341	10.2004 →	OM 457.917 D	<b>468</b>
2628, 2629	10.2004 →	OM 906.926 D	<b>245</b>	3340, 3341	10.2004 →	OM 457.918 D	<b>469</b>
2628, 2629	10.2004 →	OM 906.995 D	<b>266</b>	3340, 3341	10.2004 →	OM 457.937 D	<b>454</b>
2633	10.2004 →	OM 926.913 D	<b>282</b>	3343	10.2004 →	OM 457.937 D	<b>454</b>
2633	10.2004 →	OM 926.919 D	<b>292</b>	3343 K	01.2011 →	OM 457.917 D	<b>468</b>
2633	10.2004 →	OM 926.945 D	<b>295</b>	3343 K	01.2011 →	OM 457.918 D	<b>469</b>
2633 K	10.2004 →	OM 926.913 D	<b>282</b>	3343 S	01.2011 →	OM 457.917 D	<b>468</b>
2633 K	10.2004 →	OM 926.919 D	<b>292</b>	3343 S	01.2011 →	OM 457.918 D	<b>469</b>
2633 K	10.2004 →	OM 926.945 D	<b>295</b>	3344	10.2004 →	OM 457.961 D	<b>449</b>
2636	10.2004 →	OM 457.937 D	<b>454</b>	3344 K	10.2004 →	OM 457.961 D	<b>449</b>
2636 K	10.2004 →	OM 457.937 D	<b>454</b>	3344 K	01.2011 →	OM 457.917 D	<b>468</b>
2636 K	10.2004 →	OM 457.948 D	<b>448</b>	3344 K	01.2011 →	OM 457.918 D	<b>469</b>
2636 K	10.2005 →	OM 457.956 D	<b>454</b>	3344 K	01.2011 →	OM 457.956 D	<b>454</b>
2636 K	10.2005 →	OM 457.957 D	<b>448</b>	3344 K	01.2011 →	OM 457.957 D	<b>448</b>
2636 K	10.2005 →	OM 457.980 D	<b>470</b>	3344 S	10.2004 →	OM 457.961 D	<b>449</b>
2636 K	10.2005 →	OM 457.981 D	<b>450</b>	3535 K	06.2009 →	OM 457.937 D	<b>454</b>
2640	10.2004 →	OM 457.937 D	<b>454</b>	4135 K	06.2009 →	OM 457.956 D	<b>454</b>
2640 K	10.2004 →	OM 457.956 D	<b>454</b>	4135 K	06.2009 →	OM 457.957 D	<b>448</b>
2640 K	10.2004 →	OM 457.957 D	<b>448</b>	4140	01.2011 →	OM 457.917 D	<b>468</b>
2640 K	10.2005 →	OM 457.980 D	<b>470</b>	4140	01.2011 →	OM 457.918 D	<b>469</b>
2640 K	10.2005 →	OM 457.981 D	<b>450</b>	4140 K	06.2009 →	OM 457.956 D	<b>454</b>
2640 S, 2641 S, LS	10.2004 →	OM 457.918 D	<b>469</b>	4140 K	06.2009 →	OM 457.957 D	<b>448</b>
2643	10.2004 →	OM 457.937 D	<b>454</b>	4143 K	06.2009 →	OM 457.956 D	<b>454</b>
2643 K	10.2004 →	OM 457.956 D	<b>454</b>	4143 K	06.2009 →	OM 457.957 D	<b>448</b>
2643 K	10.2004 →	OM 457.957 D	<b>448</b>	4143 K	01.2011 →	OM 457.956 D	<b>454</b>
2643 K	10.2005 →	OM 457.980 D	<b>470</b>	4143 K	01.2011 →	OM 457.957 D	<b>448</b>
2643 K	10.2005 →	OM 457.981 D	<b>450</b>	4144	01.2006 → 12.2011	OM 457.917 D	<b>468</b>
2644 S, LS	01.2011 →	OM 457.918 D	<b>469</b>	4144	01.2006 → 12.2011	OM 457.918 D	<b>469</b>
2644 S, LS	01.2011 →	OM 457.922 D	<b>460</b>	4144	01.2011 →	OM 457.917 D	<b>468</b>
2644 S, LS	01.2011 →	OM 457.937 D	<b>454</b>	4144	01.2011 →	OM 457.918 D	<b>469</b>
2644 S, LS	01.2011 →	OM 457.948 D	<b>448</b>	4144 K	10.2004 →	OM 457.961 D	<b>449</b>
2826	12.2011 →	OM 906.990 D	<b>266</b>	<b>BOXER</b>			
2828 K	10.2004 →	OM 906.930 D	<b>246</b>	40	01.2002 → 12.2013	OM 904.932 D	<b>242</b>
2831	01.2011 →	OM 926.926 D	<b>282</b>	40	01.2002 → 12.2013	OM 904.956 D	<b>242</b>

M



			Pos				Pos			
40	01.2002 →	OM 924.915	D	290	Citaro N, Citaro MUE	01.1998 →	OM 457.942	D	446	
40	01.2002 →	OM 924.917	D	290	Citaro N, Citaro MUE	01.1998 →	OM 457.942	D	446	
40	01.2002 →	OM 924.933	D	281	Citaro N, Citaro MUE	01.1998 →	OM 457.949	D	447	
50	01.2002 → 12.2013	OM 904.932	D	242	Citaro N, Citaro MUE	01.1998 →	OM 457.950	D	449	
50	01.2002 → 12.2013	OM 904.956	D	242	Citaro N, Citaro MUE	01.1998 →	OM 457.950	D	449	
50	01.2002 →	OM 924.915	D	290	Citaro N, Citaro MUE	01.1998 →	OM 457.951	D	449	
50	01.2002 →	OM 924.917	D	290	Citaro N, Citaro MUE	01.1998 →	OM 457.957	D	448	
50	01.2002 →	OM 924.933	D	281	Citaro N, Citaro MUE	01.1998 →	OM 457.959	D	449	
60	01.2002 → 12.2013	OM 904.932	D	242	Citaro N, Citaro MUE	01.1998 →	OM 457.959	D	449	
60	01.2002 → 12.2013	OM 904.956	D	242	Citaro N, Citaro MUE	01.1998 →	OM 457.973	D	450	
60	01.2002 →	OM 924.915	D	290	Citaro N, Citaro MUE	01.1998 →	OM 457.973	D	450	
60	01.2002 →	OM 924.917	D	290	Citaro NG	04.2000 →	M 476.930	G	356	
60	01.2002 →	OM 924.933	D	281	Citaro NG	04.2000 →	M 476.933	G	356	
<b>CAPACITY</b>										
CapaCity	04.2007 →	OM 457.950	D	449	Citaro NG	04.2000 →	M 476.934	G	356	
CapaCity	04.2007 →	OM 457.959	D	449	Citaro NG	06.2000 →	M 476.932	G	356	
CapaCity	04.2007 →	OM 457.973	D	450	Citaro NG	06.2000 →	M 476.933	G	356	
CapaCity	01.2015 →	OM 470.904	D	341	Citaro NG	06.2000 →	M 476.934	G	356	
CapaCity	01.2015 →	OM 470.904	D	341	Citaro, Citaro MUE	01.1998 →	OM 902.926	D	252	
CapaCity	01.2015 →	OM 470.914	D	341	Citaro, Citaro MUE	01.1998 →	OM 902.934	D	252	
CapaCity	01.2015 →	OM 470.914	D	341	<b>CITO (O 520)</b>					
						130 kW	06.1999 →	OM 904.942	D	244
<b>CITARO (628)</b>						<b>CONECTO (O 345)</b>				
12M	05.2012 →	OM 936.910	D	316	CONECTO 12M	11.2001 →	OM 447.949	D	464	
12M	05.2012 →	OM 936.912	D	316	CONECTO 12M	11.2001 →	OM 457.951	D	449	
12M	05.2012 →	OM 936.915	D	316	CONECTO 12M	11.2001 →	OM 457.967	D	449	
12M	05.2012 →	OM 936.916	D	316	CONECTO 12M	11.2001 →	OM 902.925	D	251	
12M	05.2012 →	OM 936.919	D	318	CONECTO 12M	11.2001 →	OM 906.961	D	254	
12M	05.2012 →	OM 936.972	D	316	CONECTO 12M	11.2001 →	OM 926.939	D	286	
12M	05.2012 →	OM 936.973	D	316	CONECTO 18M	11.2001 →	OM 447.947	D	463	
12M	05.2012 →	OM 936.980	D	318	CONECTO 18M	11.2001 →	OM 447.948	D	464	
18M	05.2012 →	OM 470 LA	D	342	CONECTO 18M	11.2001 →	OM 457.943	D	446	
18M	05.2012 →	OM 470.903	D	341	CONECTO 18M	11.2001 →	OM 457.943	D	446	
18M	05.2012 →	OM 470.904	D	341	CONECTO 18M	11.2001 →	OM 457.951	D	449	
18M	05.2012 →	OM 470.906	D	341	CONECTO 18M	11.2001 →	OM 457.975	D	465	
18M	05.2012 →	OM 470.907	D	341	CONECTO C, H, M, UE	11.2001 →	OM 447.949	D	464	
18M	05.2012 →	OM 470.908	D	341	CONECTO C, H, M, UE	11.2001 →	OM 457.942	D	446	
<b>CITARO (O 530)</b>										
Citaro G	01.1999 →	OM 906.930	D	246	CONECTO C, H, M, UE	11.2001 →	OM 457.942	D	446	
Citaro G	01.1999 →	OM 906.960	D	245	CONECTO C, H, M, UE	11.2001 →	OM 457.942	D	446	
Citaro G	01.1999 →	OM 906.961	D	254	CONECTO C, H, M, UE	11.2001 →	OM 457.942	D	446	
Citaro G	01.1999 →	OM 909.901	D	256	CONECTO C, H, M, UE	11.2001 →	OM 457.942	D	446	
Citaro G	01.1999 →	OM 909.921	D	245	CONECTO C, H, M, UE	11.2001 →	OM 904.960	D	262	
Citaro G, Citaro GN3, Citaro LÜ	01.1998 →	OM 457.943	D	446	CONECTO C, H, UE	11.2001 →	OM 906.960	D	245	
Citaro G, Citaro GN3, Citaro LÜ	01.1998 →	OM 457.950	D	449	<b>ECONIC</b>					
Citaro G, Citaro GN3, Citaro LÜ	01.1998 →	OM 457.959	D	449	1828 LS	10.2004 →	M 902.903	G	277	
Citaro G, Citaro GN3, Citaro LÜ	01.1998 →	OM 457.973	D	450	1829 LS	10.2007 →	OM 902.927	D	252	
Citaro G, Citaro GN3, Citaro LÜ	01.1998 →	OM 457.973	D	450	1833 LS	10.2007 →	OM 926.934	D	292	
Citaro G, Citaro GN3, Citaro LÜ	01.1998 →	OM 457.973	D	450	2628 L	10.2000 →	M 906.900	G	279	
Citaro G, Citaro GN3, Citaro LÜ	01.1998 →	OM 457.973	D	450	<b>ECONIC 2</b>					
Citaro G, Citaro LÜ	01.1998 →	OM 457.950	D	449	1830 LL	04.2013 →	OM 936.912	D	316	
Citaro G, Citaro LÜ	01.1998 →	OM 457.959	D	449	1830 LL	04.2013 →	OM 936.972	D	316	
Citaro G, Citaro LÜ	01.1998 →	OM 457.973	D	450	1830 LL	04.2013 →	OM 936.973	D	316	
Citaro G, Citaro LÜ	01.1998 →	OM 457.973	D	450	1835 LL	04.2013 →	OM 936.972	D	316	
Citaro GNG	04.2000 →	M 476.930	G	356	2630 LL	04.2013 →	OM 936.912	D	316	
Citaro N	01.1998 →	OM 457.942	D	446	2630 LL	04.2013 →	OM 936.912	D	316	
Citaro N	01.1998 →	OM 906.930	D	246	2635 LL	04.2013 →	OM 936.912	D	316	
Citaro N	01.1998 →	OM 906.931	D	255	2635 LL	04.2013 →	OM 936.972	D	316	
Citaro N	01.1998 →	OM 906.960	D	245	<b>FPN (FlatNose)</b>					
Citaro N	01.1998 →	OM 906.961	D	254	1418	04.1989 → 04.1999	OM 372.961	D	190	
Citaro N	01.1998 →	OM 909.900	D	256	1418	04.1989 → 04.1999	OM 376.956	D	186	
Citaro N	01.1998 →	OM 909.901	D	256	L 1319	12.1985 → 12.2001	OM 376.981	D	219	
Citaro N	01.1998 →	OM 909.921	D	245	L 1319	12.1985 → 12.2001	OM 376.988	D	219	
Citaro N	01.1999 → 09.2004	OM 909.911	D	245	L 1319	12.1985 → 12.2001	OM 376.989	D	219	
Citaro N	01.1999 →	OM 906.930	D	246	L 1418 EL	07.2001 → 12.2005	OM 904.907	D	240	
Citaro N	01.1999 →	OM 906.960	D	245	LK 1414	04.1989 → 04.1999	OM 376.907	D	185	
Citaro N	01.1999 →	OM 909.901	D	256	LK 1418	01.1989 → 12.1993	OM 376.945	D	186	
Citaro N	01.1999 →	OM 909.921	D	245	LK 1418	01.1989 → 12.1993	OM 376.956	D	186	
Citaro N	04.1999 →	OM 906.962	D	254	LP 1514	07.1987 → 07.1997	OM 352.912	D	129	
Citaro N	04.1999 →	OM 906.963	D	257	LPK 1313	07.1987 → 07.1997	OM 352.912	D	129	
Citaro N, Citaro MUE	01.1998 →	OM 457.934	D	437						

					Pos						Pos
<b>FREIGHTLINER (USA)</b>						LS 1929	04.1983 → 04.1998	OM 345.913	D		377
Freightliner (USA)	07.1987 →	OM 376.911-505	D	<b>225</b>	LS 1935	05.1990 → 05.2000	OM 476.973	D		<b>401</b>	
Freightliner (USA)	07.1987 →	OM 376.911-506	D	<b>225</b>	LS 1935	05.1990 → 05.2000	OM 476.979	D		<b>401</b>	
Freightliner (USA)	07.1987 →	OM 376.911-507	D	<b>225</b>	LS 1935	05.1990 → 05.2000	OM 476.980	D		<b>401</b>	
Freightliner (USA)	07.1987 →	OM 376.911-508	D	<b>225</b>	LS 1935	05.1990 → 05.2000	OM 476.983	D		<b>401</b>	
Freightliner (USA)	07.1987 →	OM 442.969-502	D	<b>405</b>	LS 1938	10.1998 → 12.2005	OM 457.920	D		<b>453</b>	
		(USA)			LS 1938	10.1998 → 12.2005	OM 457.923	D		<b>453</b>	
Freightliner (USA)	07.1987 →	OM 442.969-503	D	<b>405</b>	LS 1938	10.1998 → 12.2005	OM 457.931	D		<b>440</b>	
		(USA)			LS 1938	01.2000 → 12.2005	OM 457.920	D		<b>453</b>	
Freightliner (USA)	07.1987 →	OM 442.969-504	D	<b>405</b>	LS 1944	11.2001 → 12.2005	OM 457.922	D		<b>460</b>	
		(USA)			LS 2635	09.1992 → 09.2002	OM 457.933	D		<b>437</b>	
Freightliner (USA)	07.1987 →	OM 447.969-501	D	<b>406</b>	<b>INTEGRO (O 550)</b>						
		(USA)			Integro	08.1998 →	OM 457.952	D		<b>449</b>	
Freightliner (USA)	07.1987 →	OM 447.969-502	D	<b>406</b>	Integro	08.1998 →	OM 457.965	D		<b>449</b>	
		(USA)			Integro	08.1998 →	OM 457.974	D		<b>457</b>	
Freightliner (USA)	07.1987 →	OM 447.969-503	D	<b>406</b>	Integro	08.1998 →	OM 926.939	D		<b>286</b>	
		(USA)			Integro	02.2013 →	OM 936.915	D		<b>316</b>	
Freightliner (USA)	07.1987 →	OM 904.926	D	<b>243</b>	Integro	02.2013 →	OM 936.915	D		<b>316</b>	
					Integro	02.2013 →	OM 936.919	D		<b>318</b>	
<b>HPN (LongNose)</b>					Integro	02.2013 →	OM 936.919	D		<b>318</b>	
1717	01.2000 → 12.2002	OM 366.957	D	<b>195</b>	Integro	02.2013 →	OM 936.923	D		<b>319</b>	
1718	07.1990 → 07.2000	OM 372.956	D	<b>190</b>	Integro	02.2013 →	OM 936.923	D		<b>319</b>	
1718	07.1990 → 07.2000	OM 372.961	D	<b>190</b>	Integro L	01.2006 →	OM 457.952	D		<b>449</b>	
1720	02.1998 → 12.2005	OM 366.984	D	<b>190</b>	Integro L	01.2006 →	OM 457.952	D		<b>449</b>	
2038	11.1991 → 08.1996	OM 440.989	D	<b>432</b>	Integro L	01.2006 →	OM 457.952	D		<b>449</b>	
2423 K	05.1999 → 01.2006	OM 906.982	D	<b>258</b>	Integro L	01.2006 →	OM 457.952	D		<b>449</b>	
2428	03.2001 → 01.2006	OM 906.926	D	<b>245</b>	Integro L	01.2006 →	OM 457.965	D		<b>449</b>	
2638 S	09.1995 → 12.1999	OM 440.989	D	<b>432</b>	Integro L	01.2006 →	OM 457.965	D		<b>449</b>	
2726	01.2008 → 12.2011	OM 906.998	D	<b>266</b>	Integro L	01.2006 →	OM 926.939	D		<b>286</b>	
L 1214	04.1989 → 04.1999	OM 366.913	D	<b>208</b>	Integro, Integro M	01.2006 →	OM 457.952	D		<b>449</b>	
L 1215	06.1990 → 06.1996	OM 366.984	D	<b>190</b>	Integro, Integro M	01.2006 →	OM 457.952	D		<b>449</b>	
L 1218 EL	07.2001 → 12.2005	OM 904.911	D	<b>242</b>	Integro, Integro M	01.2006 →	OM 457.964	D		<b>449</b>	
L 1618	04.1989 → 04.1999	OM 376.945	D	<b>186</b>	Integro, Integro M	01.2006 →	OM 457.965	D		<b>449</b>	
L 1618	04.1989 → 04.1999	OM 376.955	D	<b>186</b>	Integro, Integro M	01.2006 →	OM 926.939	D		<b>286</b>	
L 1620	12.1996 → 12.2005	OM 377.964	D	<b>187</b>	<b>INTOURO</b>						
L 1620	12.1996 → 12.2005	OM 377.983	D	<b>187</b>	Intouro	11.2013 →	OM 936.915	D		<b>316</b>	
L 1620	06.2000 → 12.2005	OM 366.984	D	<b>190</b>	Intouro	11.2013 →	OM 936.915	D		<b>316</b>	
L 1621	08.1989 → 08.1999	OM 376.986	D	<b>220</b>	Intouro	11.2013 →	OM 936.919	D		<b>318</b>	
L 1622	07.2001 → 12.2005	OM 924.910	D	<b>290</b>	Intouro	11.2013 →	OM 936.919	D		<b>318</b>	
L 1622	07.2001 → 12.2005	OM 924.910	D	<b>290</b>	Intouro	11.2013 →	OM 936.923	D		<b>319</b>	
L 1623	01.2006 → 11.2011	OM 906.982	D	<b>258</b>	Intouro	11.2013 →	OM 936.923	D		<b>319</b>	
L 1625	05.1990 → 05.2000	OM 475.950	D	<b>401</b>	Intouro, Intouro E,	01.2005 →	OM 457.965	D		<b>449</b>	
L 1625	05.1990 → 05.2000	OM 475.950	D	<b>401</b>	Intouro M, Intouro ME						
L 1714	12.1991 → 02.2001	OM 366.913	D	<b>208</b>	Intouro, Intouro E,	01.2005 →	OM 457.965	D		<b>449</b>	
L 1714	12.1991 → 02.2001	OM 376.930	D	<b>185</b>	Intouro M, Intouro ME						
L 1721	12.1992 → 12.2004	OM 376.986	D	<b>220</b>	Intouro, Intouro E,	01.2005 →	OM 457.965	D		<b>449</b>	
L 2215	01.1983 → 12.1988	OM 352.916	D	<b>133</b>	Intouro M, Intouro ME						
L 2219	01.1976 → 04.1987	OM 345.900	D	<b>363</b>	Intouro, Intouro E,	01.2005 →	OM 926.939	D		<b>286</b>	
L 2220	05.1987 → 05.1997	OM 345.973	D	<b>368</b>	Intouro M, Intouro ME						
L 2225	01.1989 → 12.1991	OM 345.949	D	<b>368</b>	<b>LK/LN2</b>						
L 2314	09.1989 → 09.1999	OM 366.913	D	<b>208</b>	1114 A	02.1987 → 12.1998	OM 356.916	D		<b>208</b>	
L 2318	04.1989 → 07.1999	OM 376.946	D	<b>186</b>	1114 A	02.1987 → 12.1998	OM 366.931	D		<b>208</b>	
L 2318	04.1989 → 07.1999	OM 376.955	D	<b>186</b>	1114 A	02.1987 → 12.1998	OM 366.935	D		<b>208</b>	
L 2325	05.1990 → 05.2000	OM 475.950	D	<b>401</b>	1114 AK	02.1987 → 02.1993	OM 366.918	D		<b>208</b>	
L 2418	03.1991 → 03.2001	OM 376.946	D	<b>186</b>	1114 AK	02.1987 → 02.1993	OM 366.931	D		<b>208</b>	
L 2418	03.1991 → 03.2001	OM 376.955	D	<b>186</b>	1114 AK	02.1992 → 12.1998	OM 356.903	D		<b>208</b>	
L 2635	09.1992 → 09.2002	OM 457.933	D	<b>437</b>	1114 K	03.1984 → 02.1993	OM 366.907	D		<b>208</b>	
L 2638	08.1998 → 12.2005	OM 440.989	D	<b>432</b>	1114 K	03.1984 → 02.1993	OM 366.914	D		<b>208</b>	
LK 1214	04.1989 → 04.1999	OM 366.913	D	<b>208</b>	1114 K	02.1992 → 12.1998	OM 356.904	D		<b>208</b>	
LK 1618	04.1989 → 04.1999	OM 376.945	D	<b>186</b>	1114 S	03.1984 → 02.1993	OM 366.907	D		<b>208</b>	
LK 1618	04.1989 → 04.1999	OM 376.955	D	<b>186</b>	1114 S	03.1984 → 02.1993	OM 366.914	D		<b>208</b>	
LK 1620, LK 1621	08.1989 → 08.1999	OM 376.986	D	<b>220</b>	1114 S	02.1992 → 12.1998	OM 356.904	D		<b>208</b>	
LK 2325	01.1996 →	OM 475.950	D	<b>401</b>	1114 S	02.1992 → 12.1998	OM 356.904	D		<b>208</b>	
LK 2635	01.1996 →	OM 457.933	D	<b>437</b>	1114,1114 L	01.1984 → 12.1998	M 372.927	G		<b>184</b>	
LS 1418 E	01.2000 → 12.2002	OM 376.955	D	<b>186</b>	1114,1114 L	01.1984 → 12.1998	OM 344.920	D		<b>163</b>	
LS 1625	05.1990 → 05.2000	OM 475.950	D	<b>401</b>	1114,1114 L	01.1984 → 12.1998	OM 344.991	D		<b>134</b>	
LS 1630	05.1990 → 05.2000	OM 475.982	D	<b>417</b>	1114,1114 L	01.1984 → 12.1998	OM 374.980	D		<b>207</b>	
LS 1632	01.1999 → 12.2002	OM 475.978	D	<b>417</b>	1114,1114 L	01.1984 → 12.1998	OM 374.984	D		<b>207</b>	
LS 1632	01.1999 → 12.2002	OM 475.979	D	<b>458</b>	1114,1114 L	01.1984 → 12.1998	OM 390.900-006	D		<b>189</b>	
LS 1636	10.2003 → 12.2005	OM 457.915	D	<b>461</b>			(AMS)				
LS 1924	01.1976 → 12.1983	OM 355.984	D	<b>367</b>	1114,1114 L	01.1984 → 12.1998	OM 390.900-007	D		<b>189</b>	
					1114,1114 L	03.1984 → 02.1993	OM 366.907	D		<b>208</b>	
					1114,1114 L	03.1984 → 02.1993	OM 366.914	D		<b>208</b>	

M

		Pos			Pos
1114,1114 L 08.1984 → 12.1998	OM 306.900-016 (ZA) D	206	1314 AK 12.1992 → 12.1998	OM 356.909 D	208
1114,1114 L 07.1986 → 02.1993	OM 366.930 D	208	1314 K 07.1984 → 02.1993	OM 366.907 D	208
1114,1114 L 02.1992 → 12.1998	OM 356.904 D	208	1314 K 07.1984 → 02.1993	OM 366.914 D	208
1117 A 06.1987 → 02.1993	OM 366.966 D	195	1314 K 12.1992 → 12.1998	OM 356.909 D	208
1117 A 06.1987 → 12.1998	OM 356.959 D	190	1317 AK 08.1984 → 02.1993	OM 366.944 D	195
1117 A 09.1988 → 02.1993	OM 366.975 D	200	1317 AK 02.1987 → 02.1993	OM 366.966 D	195
1117 A 09.1988 → 02.1993	OM 366.976 D	195	1317 AK 12.1992 → 12.1998	OM 356.945 D	190
1117 A 02.1992 → 12.1998	OM 356.947 D	190	1317 AK 03.1994 → 12.1998	OM 357.907 D	190
1117 A 03.1994 → 12.1998	OM 357.906 D	190	1317 K 07.1984 → 12.1998	OM 357.961 D	190
1117 AK 03.1994 → 12.1998	OM 357.902 D	190	1317 K 08.1984 → 02.1993	OM 366.962 D	195
1117 AK 03.1994 → 12.1998	OM 357.906 D	190	1317 K 03.1994 → 12.1998	OM 357.902 D	190
1117 AK 03.1994 → 12.1998	OM 357.907 D	190	1317 K 03.1996 → 12.1998	OM 904.907 D	240
1117 K 04.1984 → 02.1993	OM 366.953 D	195	1317 LS 03.1996 → 12.1998	OM 904.907 D	240
1117 K 08.1984 → 02.1993	OM 366.962 D	195	1317 S,1317 LS 01.1984 → 12.1998	OM 357.961 D	190
1117 K 02.1992 → 12.1998	OM 366.941 D	190	1317 S,1317 LS 08.1984 → 02.1993	OM 366.946 D	195
1117 K 03.1994 → 12.1998	OM 357.901 D	190	1317 S,1317 LS 08.1984 → 02.1993	OM 366.953 D	195
1117 K 03.1996 → 12.1998	OM 904.907 D	240	1317 S,1317 LS 08.1984 → 02.1993	OM 366.962 D	195
1117 LO 03.1996 → 12.1998	OM 904.907 D	240	1317 S,1317 LS 12.1992 → 12.1998	OM 356.944 D	230
1117 O,1117 LO 03.1984 → 12.1998	OM 366.971 D	195	1317 S,1317 LS 03.1994 → 12.1998	OM 357.902 D	190
1117 O,1117 LO 03.1993 → 12.1998	OM 356.949 D	190	1317,1317 L 01.1984 → 12.1998	OM 344.950 (USA) D	146
1117 O,1117 LO 03.1994 → 12.1998	OM 357.919 D	190	1317,1317 L 01.1984 → 12.1998	OM 344.954 D	144
1117 S 03.1996 → 12.1998	OM 904.907 D	240	1317,1317 L 01.1984 → 12.1998	OM 352.900-016 D	135
1117 S,1117 LS 04.1984 → 02.1993	OM 366.953 D	195	1317,1317 L 01.1984 → 12.1998	OM 390.900-405 D	189
1117 S,1117 LS 08.1984 → 02.1993	OM 366.962 D	195	(AMS)		
1117 S,1117 LS 02.1992 → 12.1998	OM 366.941 D	190	1317,1317 L 01.1984 → 12.1998	OM 390.900-407 D	189
1117 S,1117 LS 03.1994 → 12.1998	OM 357.901 D	190	1317,1317 L 08.1984 → 02.1993	OM 366.946 D	195
1117 S,1117 LS 03.1994 → 12.1998	OM 357.918 D	190	1317,1317 L 08.1984 → 02.1993	OM 366.953 D	195
1117,1117 L 01.1984 → 12.1998	OM 344.950 (USA) D	146	1317,1317 L 08.1984 → 02.1993	OM 366.962 D	195
1117,1117 L 04.1984 → 02.1993	OM 366.953 D	195	1317,1317 L 12.1992 → 12.1993	OM 356.944 D	230
1117,1117 L 08.1984 → 02.1993	OM 366.962 D	195	1317,1317 L 03.1994 → 12.1998	OM 357.902 D	190
1117,1117 L 07.1986 → 02.1993	OM 366.970 D	195	1317,1317 L 03.1994 → 12.1998	OM 357.961 D	190
1117,1117 L 02.1992 → 12.1998	OM 366.941 D	190	1317,1317 L 03.1996 → 12.1998	OM 904.907 D	240
1117,1117 L 03.1994 → 12.1998	OM 357.901 D	190	1320 AK 12.1992 → 12.1998	OM 356.995 D	190
1117,1117 L 03.1994 → 12.1998	OM 357.918 D	190	1320 S,1320 LS 10.1984 → 02.1993	OM 366.980 D	190
1117,1117 L 03.1996 → 12.1998	OM 904.907 D	240	1320 S,1320 LS 10.1984 → 02.1993	OM 366.988 D	190
1120 O,1120 LO 02.1992 → 12.1998	OM 356.993 D	190	1320 S,1320 LS 10.1984 → 02.1993	OM 366.992 D	190
1120 O,1120 LO 02.1992 → 12.1998	OM 366.993 D	190	1320 S,1320 LS 01.1991 → 12.1998	OM 366.997 D	190
1120 O,1120 LO 06.1994 → 12.1998	OM 357.929 D	190	1320 S,1320 LS 12.1992 → 12.1998	OM 356.992 D	190
1120 S,1120 LS 10.1984 → 02.1993	OM 366.988 D	190	1320 S,1320 LS 03.1994 → 12.1998	OM 357.921 D	190
1120 S,1120 LS 02.1992 → 12.1998	OM 356.986 D	190	1320 S,1320 LS 03.1994 → 12.1998	OM 357.932 D	190
1120 S,1120 LS 03.1994 → 12.1998	OM 357.932 D	190	1320,1320 L 01.1984 → 12.1998	M 376.923 G	182
1120 S,1120 LS 06.1994 → 12.1998	OM 357.920 D	190	1320,1320 L 01.1984 → 12.1998	M 376.924 G	182
1120 S,1120 LS 06.1994 → 12.1998	OM 357.927 D	190	1320,1320 L 10.1984 → 02.1993	OM 366.980 D	190
1120,1120 L 10.1984 → 02.1993	OM 366.988 D	190	1320,1320 L 10.1984 → 02.1993	OM 366.988 D	190
1120,1120 L 02.1992 → 08.1993	OM 356.986 D	190	1320,1320 L 10.1984 → 02.1993	OM 366.992 D	190
1120,1120 L 12.1992 → 12.1998	OM 356.992 D	190	1320,1320 L 10.1984 → 02.1993	OM 366.997 D	190
1120,1120 L 03.1994 → 12.1998	OM 357.932 D	190	1320,1320 L 12.1992 → 12.1998	OM 356.992 D	190
1120,1120 L 06.1994 → 12.1998	OM 357.920 D	190	1320,1320 L 03.1994 → 12.1998	OM 357.921 D	190
1120,1120 L 06.1994 → 12.1998	OM 357.927 D	190	1320,1320 L 03.1994 → 12.1998	OM 357.932 D	190
1214 A 01.1984 → 12.1998	M 372.927 G	184	1324 S,1324 LS 01.1991 → 12.1998	OM 356.983 D	190
1214 A 01.1984 → 12.1998	OM 306.900-016 (ZA) D	206	1324 S,1324 LS 01.1991 → 12.1998	OM 366.999 D	190
1214 A 01.1984 → 12.1998	OM 374.985 D	207	1324 S,1324 LS 03.1994 → 12.1998	OM 357.940 D	190
1214 A 03.1984 → 12.1998	OM 366.913 D	208	1324 S,1324 LS 03.1994 → 12.1998	OM 357.948 D	190
1214 K 06.1997 → 12.2005	OM 354.920 D	212	1324,1324 L 01.1991 → 12.1998	OM 356.983 D	190
1214 L 06.1997 → 12.2005	OM 354.920 D	212	1324,1324 L 01.1991 → 12.1998	OM 366.999 D	190
1314 07.1984 → 02.1993	OM 366.907 D	208	1324,1324 L 03.1994 → 12.1998	OM 357.940 D	190
1314 07.1984 → 02.1993	OM 366.914 D	208	1514 K 03.1994 → 12.1998	OM 357.948 D	190
1314 07.1984 → 12.1998	OM 306.900-016 (ZA) D	206	1514 K 01.1989 → 02.1993	OM 366.936 D	208
1314 07.1984 → 12.1998	OM 344.991 D	134	1514 K 12.1992 → 12.1998	OM 356.908 D	208
1314 07.1984 → 12.1998	OM 344.997 D	134	1514,1514 L 01.1984 → 12.1998	OM 352.900-016 D	135
1314 07.1984 → 12.1998	OM 352.900-016 D	135	1514,1514 L 01.1984 → 12.1998	OM 390.900-006 D	189
1314 07.1984 → 12.1998	OM 390.900-006 (AMS) D	189	(AMS)		
1314 07.1984 → 12.1998	OM 390.900-007 D	189	1514,1514 L 01.1989 → 02.1993	OM 366.936 D	208
1314 12.1992 → 12.1993	OM 356.910 D	208	1514,1514 L 12.1992 → 12.1998	OM 356.908 D	208
1314 AK 06.1987 → 02.1993	OM 366.918 D	208	1517 K 01.1989 → 12.1992	OM 366.979 D	195
1314 AK 06.1987 → 02.1993	OM 366.937 D	208	1517 K 01.1989 → 02.1993	OM 366.945 D	195
			1517 K 01.1989 → 12.1998	OM 356.946 D	190
			1517 K 01.1989 → 12.1998	OM 357.963 D	190
			1517 K 12.1992 → 12.1998	OM 356.953 D	190



				Pos					Pos
1517 K	03.1994 → 12.1998	OM 357.903	D	190	814 S	02.1992 → 12.1998	OM 356.902	D	208
1517 K	03.1996 → 12.1998	OM 904.907	D	240	814 S	03.1994 → 12.1998	OM 354.920	D	212
1517,1517 L	01.1984 → 12.1998	OM 344.955	D	144	814 S	03.1996 → 12.1998	OM 904.906	D	240
1517,1517 L	01.1984 → 12.1998	OM 352.900-016	D	135	814,814 L	03.1994 → 12.1998	OM 354.920	D	212
1517,1517 L	01.1984 → 12.1998	OM 390.900-405	D	189	814,814L	03.1984 → 02.1993	OM 366.905	D	208
		(AMS)			814,814L	03.1984 → 02.1993	OM 366.907	D	208
1517,1517 L	01.1984 → 12.1998	OM 390.900-407	D	189	814,814L	04.1984 → 02.1993	OM 366.906	D	208
1517,1517 L	01.1984 → 12.1998	OM 396.900-407	D	165	814,814L	06.1984 → 02.1993	OM 366.910	D	208
1517,1517 L	10.1988 → 12.1992	OM 366.979	D	195	814,814L	02.1992 → 12.1998	OM 356.901	D	208
1517,1517 L	10.1988 → 02.1993	OM 366.945	D	195	814,814L	02.1992 → 12.1998	OM 356.902	D	208
1517,1517 L	12.1992 → 12.1998	OM 356.946	D	190	814,814L	03.1996 → 12.1998	OM 904.906	D	240
1517,1517 L	12.1992 → 12.1998	OM 356.953	D	190	817 K	01.1986 → 02.1993	OM 366.967	D	195
1517,1517 L	03.1994 → 12.1998	OM 357.903	D	190	817 K	02.1992 → 12.1998	OM 366.943	D	190
1517,1517 L	03.1994 → 12.1998	OM 357.962	D	190	817 K	03.1994 → 12.1998	OM 357.900	D	190
1517,1517 L	03.1994 → 12.1998	OM 357.963	D	190	817 K	03.1996 → 12.1998	OM 904.907	D	240
1517,1517 L	03.1996 → 12.1998	OM 904.907	D	240	817 LO	03.1996 → 12.1998	OM 904.907	D	240
1520,1520 L	01.1989 → 12.1992	OM 366.995	D	190	817 O, 817 LO	06.1986 → 02.1993	OM 366.969	D	195
1520,1520 L	12.1992 → 12.1998	OM 356.990	D	190	817 O, 817 LO	02.1992 → 12.1998	OM 356.948	D	190
1520,1520 L	03.1994 → 12.1998	OM 357.922	D	190	817 O, 817 LO	03.1994 → 12.1998	OM 357.917	D	190
1520,1520 L	03.1994 → 12.1998	OM 357.930	D	190	817 S,817 LS	01.1986 → 02.1993	OM 366.967	D	195
1524,1524 L	01.1984 → 12.1998	OM 345.970 (BRA)	D	368	817 S,817 LS	01.1986 → 02.1993	OM 366.968	D	195
1524,1524 L	02.1991 → 08.1994	OM 356.999	D	197	817 S,817 LS	02.1992 → 12.1998	OM 366.942	D	190
1524,1524 L	02.1991 → 12.1998	OM 366.999	D	190	817 S,817 LS	02.1992 → 12.1998	OM 366.943	D	190
1524,1524 L	03.1994 → 12.1998	OM 357.941	D	190	817 S,817 LS	03.1994 → 12.1998	OM 357.900	D	190
1524,1524 L	03.1994 → 12.1998	OM 357.947	D	190	817 S,817 LS	03.1996 → 12.1998	OM 904.907	D	240
1720	01.1984 → 12.1998	OM 357.922	D	190	817,817 L	01.1984 → 12.1998	M 376.923	G	182
1720	01.1984 → 12.1998	OM 366.995	D	190	817,817 L	01.1984 → 12.1998	M 376.924	G	182
1723, 1724	01.1984 → 12.1998	OM 466.900-005	D	388	817,817 L	01.1986 → 02.1993	OM 366.967	D	195
		(AFS)			817,817 L	01.1986 → 02.1993	OM 366.968	D	195
1723, 1724	06.1988 → 12.1998	OM 366.999	D	190	817,817 L	02.1992 → 12.1998	OM 366.942	D	190
2020 L	02.1984 → 02.1993	OM 366.992	D	190	817,817 L	02.1992 → 12.1998	OM 366.943	D	190
2020 L	10.1984 → 02.1993	OM 366.988	D	190	817,817 L	03.1994 → 12.1998	OM 357.900	D	190
2020 L	01.1989 → 12.1992	OM 366.995	D	190	817,817 L	03.1994 → 12.1998	OM 357.916	D	190
2020 L	01.1991 → 12.1998	OM 366.997	D	190	817,817 L	03.1996 → 12.1998	OM 904.907	D	240
2024 L	12.1988 → 12.1998	OM 356.999	D	197	914	03.1984 → 02.1993	OM 366.905	D	208
2024 L	03.1994 → 12.1998	OM 357.941	D	190	914	03.1984 → 02.1993	OM 366.907	D	208
2024 L	03.1994 → 12.1998	OM 357.947	D	190	914	03.1984 → 12.1998	OM 374.980	D	207
709	03.1984 → 02.1993	OM 364.907	D	209	914	03.1984 → 12.1998	OM 374.981	D	191
709	02.1992 → 12.1998	OM 364.918	D	223	914	03.1984 → 12.1998	OM 374.984	D	207
709 K	03.1984 → 10.1990	OM 364.907	D	209	914	07.1986 → 02.1993	OM 366.930	D	208
709 K	02.1992 → 10.1990	OM 364.918	D	223	914	02.1992 → 12.1998	OM 356.901	D	208
710	09.1995 → 12.2005	OM 364.907	D	209	914	10.1994 → 12.1998	OM 374.982	D	191
711	03.1994 → 12.1998	OM 354.900	D	212	914 AK	02.1987 → 02.1993	OM 366.918	D	208
711	03.1996 → 12.1998	OM 904.905	D	240	914 AK	02.1987 → 02.1993	OM 366.944	D	195
712	07.2001 → 12.2011	OM 364.979	D	226	914 AK	02.1987 → 02.1993	OM 366.945	D	195
809	03.1984 → 02.1993	OM 364.907	D	209	914 AK	02.1992 → 12.1998	OM 356.903	D	208
809	02.1992 → 12.1998	OM 364.918	D	223	914 K	03.1984 → 02.1993	OM 366.905	D	208
809 K	03.1984 → 02.1993	OM 364.907	D	209	914 K	03.1984 → 02.1993	OM 366.907	D	208
809 K	02.1992 → 12.1998	OM 364.918	D	223	914 K	02.1992 → 12.1998	OM 356.901	D	208
811	03.1994 → 12.1998	OM 354.900	D	212	917	03.1994 → 12.1998	OM 357.900	D	190
811	03.1996 → 12.1998	OM 904.905	D	240	917	03.1996 → 12.1998	OM 904.907	D	240
811 K	03.1994 → 12.1998	OM 354.900	D	212	917 AK	03.1994 → 12.1998	OM 357.906	D	190
811 K	03.1996 → 12.1998	OM 904.905	D	240	917 K	03.1994 → 12.1998	OM 357.900	D	190
814 K	03.1984 → 02.1993	OM 366.905	D	208	917 K	03.1996 → 12.1998	OM 904.907	D	240
814 K	03.1984 → 02.1993	OM 366.907	D	208	O 1114 ,O 1114 L	12.1985 → 02.1993	OM 366.933	D	208
814 K	04.1984 → 02.1993	OM 366.906	D	208	O 1114 ,O 1114 L	02.1992 → 12.1998	OM 356.907	D	208
814 K	06.1984 → 02.1993	OM 366.910	D	208	O 814 , O 814 L	03.1994 → 12.1998	OM 354.921	D	213
814 K	02.1992 → 12.1998	OM 356.901	D	208	LO				
814 K	02.1992 → 12.1998	OM 356.902	D	208	LO 608D	09.1973 → 01.1987	OM 314.910	D	131
814 K	03.1994 → 12.1998	OM 354.920	D	212	LO 812	03.1988 → 12.2005	OM 364.979	D	226
814 K	03.1996 → 12.1998	OM 904.906	D	240	LO 812	01.1990 → 03.2004	OM 904.906	D	240
814 LO	03.1996 → 12.1998	OM 904.906	D	240	LO 813	01.1990 → 03.2004	OM 904.906	D	240
814 O, 814 LO	12.1986 → 02.1993	OM 366.932	D	208	LO 914	01.1990 → 06.2004	OM 904.928	D	244
814 O, 814 LO	02.1992 → 12.1998	OM 356.906	D	208	LO 915	01.1990 → 06.2006	OM 904.928	D	244
814 S	03.1984 → 02.1993	OM 366.905	D	208	LP				
814 S	03.1984 → 02.1993	OM 366.907	D	208	L 608 D	09.1973 → 01.1987	OM 314.915	D	131
814 S	04.1984 → 02.1993	OM 366.906	D	208	LP 1013	11.1976 → 12.1984	OM 353.914	D	141
814 S	06.1984 → 02.1993	OM 366.910	D	208	LP 1013, LPL 1013	11.1976 → 12.1984	OM 353.904	D	130
814 S	02.1992 → 12.1998	OM 356.901	D	208	LP 1013, LPL 1013	11.1976 → 12.1984	OM 353.981	D	139

M

# MERCEDES-BENZ

		Pos			Pos		
LP 1013, LPL 1013	11.1976 → 12.1984	OM 353.982 D	<b>139</b>	LPK 913	03.1973 → 12.1984	OM 353.981 D	<b>139</b>
LP 1013, LPL 1013	04.1979 → 12.1984	OM 353.965 D	<b>130</b>	LPK 913	04.1976 → 12.1984	OM 353.982 D	<b>139</b>
LP 1113, LPL 1113	01.1980 → 12.1984	M 352.924 B	<b>126</b>	LPK 913	04.1979 → 12.1984	OM 353.965 D	<b>130</b>
LP 1113, LPL 1113	01.1980 → 12.1984	OM 344.920 D	<b>163</b>	LPK 913	10.1969 → 10.1977	OM 314.910 D	<b>131</b>
LP 1113, LPL 1113	01.1980 → 12.1984	OM 344.964 (USA) D	<b>157</b>	LPO 608	10.1969 → 10.1977	OM 314.944 D	<b>131</b>
LP 1113, LPL 1113	01.1980 → 12.1984	OM 344.991 D	<b>134</b>	LPO 709	11.1977 → 12.1984	OM 314.910 D	<b>131</b>
LP 1113, LPL 1113	01.1980 → 12.1984	OM 352.900-016 D	<b>135</b>	LPO 709	11.1977 → 12.1984	OM 314.944 D	<b>131</b>
LP 1113, LPL 1113	01.1980 → 12.1984	OM 353.904 D	<b>130</b>	LPO 808, LPO 809	10.1969 → 10.1977	OM 314.910 D	<b>131</b>
LP 1113, LPL 1113	01.1980 → 12.1984	OM 353.965 D	<b>130</b>	LPO 808, LPO 809	10.1969 → 10.1977	OM 314.944 D	<b>131</b>
LP 1113, LPL 1113	01.1980 → 12.1984	OM 353.982 D	<b>139</b>	LPO 811	10.1969 → 02.1973	OM 353.915 D	<b>129</b>
LP 1113, LPL 1113	01.1980 → 12.1984	OM 396.900-005 D	<b>148</b>	LPO 813	10.1969 → 12.1984	OM 353.941 D	<b>130</b>
LP 1113, LPL 1113	01.1980 → 12.1984	OM 396.900-012 D	<b>148</b>	LPO 813	12.1969 → 12.1984	OM 353.904 D	<b>130</b>
LP 608, LPL 608	09.1964 → 12.1984	OM 314.964 D	<b>131</b>	LPO 813	04.1979 → 12.1984	OM 353.965 D	<b>130</b>
LP 608, LPL 608	09.1964 → 12.1984	OM 314.965 D	<b>131</b>	LPS 608, LPLS 608	09.1964 → 12.1984	OM 314.964 D	<b>131</b>
LP 608, LPL 608	10.1969 → 10.1977	OM 314.910 D	<b>131</b>	LPS 608, LPLS 608	09.1964 → 12.1984	OM 314.965 D	<b>131</b>
LP 608, LPL 608	10.1969 → 10.1977	OM 314.944 D	<b>131</b>	LPS 608, LPLS 608	10.1969 → 10.1977	OM 314.910 D	<b>131</b>
LP 709, LPL 709	09.1964 → 12.1984	OM 314.964 D	<b>131</b>	LPS 608, LPLS 608	10.1969 → 10.1977	OM 314.944 D	<b>131</b>
LP 709, LPL 709	09.1964 → 12.1984	OM 314.965 D	<b>131</b>	LPS 709, LPLS 709	09.1964 → 12.1984	OM 314.964 D	<b>131</b>
LP 709, LPL 709	11.1977 → 12.1984	OM 314.910 D	<b>131</b>	LPS 709, LPLS 709	09.1964 → 12.1984	OM 314.965 D	<b>131</b>
LP 709, LPL 709	11.1977 → 12.1984	OM 314.944 D	<b>131</b>	LPS 709, LPLS 709	11.1977 → 12.1984	OM 314.910 D	<b>131</b>
LP 808, LPL 808	10.1969 → 10.1977	OM 314.910 D	<b>131</b>	LPS 709, LPLS 709	11.1977 → 12.1984	OM 314.944 D	<b>131</b>
LP 808, LPL 808	10.1969 → 10.1977	OM 314.944 D	<b>131</b>	LPS 811	10.1969 → 02.1973	OM 353.903 D	<b>129</b>
LP 808, LPL 808	10.1969 → 12.1984	OM 314.964 D	<b>131</b>	LPS 813, LPLS 813	03.1973 → 12.1984	OM 353.904 D	<b>130</b>
LP 808, LPL 808	10.1969 → 12.1984	OM 314.965 D	<b>131</b>	LPS 813, LPLS 813	03.1973 → 12.1984	OM 353.981 D	<b>139</b>
LP 809, LPL 808, LPL 809	09.1964 → 12.1984	OM 314.964 D	<b>131</b>	LPS 813, LPLS 813	04.1979 → 12.1984	OM 353.965 D	<b>130</b>
LP 809, LPL 808, LPL 809	09.1964 → 12.1984	OM 314.965 D	<b>131</b>	LPS 911 B	01.1967 → 03.1977	OM 352.907 D	<b>129</b>
LP 809, LPL 808, LPL 809	11.1977 → 12.1984	OM 314.910 D	<b>131</b>	LPS 911 B	01.1967 → 03.1977	OM 352.986 D	<b>129</b>
LP 809, LPL 808, LPL 809	11.1977 → 12.1984	OM 314.944 D	<b>131</b>	LPS 913	12.1969 → 12.1984	OM 353.904 D	<b>130</b>
LP 811	10.1969 → 02.1973	OM 353.903 D	<b>129</b>	LPS 913	04.1979 → 12.1984	OM 353.965 D	<b>130</b>
LP 813, LPL 813	03.1973 → 12.1984	OM 353.904 D	<b>130</b>	<b>MK</b>			
LP 813, LPL 813	03.1973 → 12.1984	OM 353.981 D	<b>139</b>	1222	07.1989 → 09.1993	OM 441.913 D	<b>503</b>
LP 813, LPL 813	04.1976 → 12.1984	OM 353.982 D	<b>139</b>	1222	07.1989 → 07.1994	OM 441.925 D	<b>503</b>
LP 813, LPL 813	04.1979 → 12.1984	OM 353.965 D	<b>130</b>	1222	07.1989 → 08.1994	OM 441.905 D	<b>503</b>
LP 911 B	01.1967 → 03.1977	OM 352.907 D	<b>129</b>	1222	07.1989 → 08.1994	OM 441.923 D	<b>503</b>
LP 911 B	01.1967 → 03.1977	OM 352.986 D	<b>129</b>	1222 A, 1222 LA	09.1989 → 07.1994	OM 441.914 D	<b>503</b>
LP 913, LPL 913	12.1969 → 02.1977	OM 353.904 D	<b>130</b>	1222 A, 1222 LA	09.1989 → 07.1994	OM 441.926 D	<b>503</b>
LP 913, LPL 913	03.1973 → 12.1984	OM 353.981 D	<b>139</b>	1222 S, 1222 LS	07.1989 → 09.1993	OM 441.913 D	<b>503</b>
LP 913, LPL 913	04.1979 → 12.1984	OM 353.965 D	<b>130</b>	1222 S, 1222 LS	07.1989 → 07.1994	OM 441.925 D	<b>503</b>
LP 913, LPL 913	04.1979 → 12.1984	OM 353.982 D	<b>139</b>	1222 S, 1222 LS	07.1989 → 08.1994	OM 441.905 D	<b>503</b>
LP 913, LPL 913	06.1985 → 12.1984	OM 374.950 D	<b>214</b>	1222 S, 1222 LS	07.1989 → 08.1994	OM 441.923 D	<b>503</b>
LPK 1013	11.1976 → 12.1984	OM 353.904 D	<b>130</b>	1227 A	01.1992 → 07.1992	OM 401.973 D	<b>336</b>
LPK 1013	11.1976 → 12.1984	OM 353.981 D	<b>139</b>	1227 A	01.1992 → 07.1992	OM 401.989 D	<b>336</b>
LPK 1013	11.1976 → 12.1984	OM 353.982 D	<b>139</b>	1417	07.1989 → 08.1994	OM 366.952 D	<b>195</b>
LPK 1013	04.1979 → 12.1984	OM 353.965 D	<b>130</b>	1417	07.1989 → 09.1996	OM 356.940 D	<b>190</b>
LPK 1113	01.1981 → 12.1984	OM 353.904 D	<b>130</b>	1417	07.1992 → 09.1996	OM 356.943 D	<b>190</b>
LPK 1113	01.1981 → 12.1984	OM 353.965 D	<b>130</b>	1417	01.1994 → 09.1996	OM 357.915 D	<b>190</b>
LPK 1113	01.1981 → 12.1984	OM 353.982 D	<b>139</b>	1417 A	09.1989 → 08.1994	OM 366.952 D	<b>195</b>
LPK 608	10.1969 → 10.1977	OM 314.910 D	<b>131</b>	1417 A	07.1992 → 09.1996	OM 356.943 D	<b>190</b>
LPK 608	10.1969 → 10.1977	OM 314.944 D	<b>131</b>	1417 A	01.1994 → 09.1996	OM 357.915 D	<b>190</b>
LPK 608	10.1969 → 10.1977	OM 314.964 D	<b>131</b>	1417 AK	09.1989 → 08.1994	OM 366.952 D	<b>195</b>
LPK 608	10.1969 → 10.1977	OM 314.965 D	<b>131</b>	1417 AK	09.1989 → 09.1996	OM 356.940 D	<b>190</b>
LPK 709	11.1977 → 12.1984	OM 314.910 D	<b>131</b>	1417 AK	07.1992 → 09.1996	OM 356.943 D	<b>190</b>
LPK 709	11.1977 → 12.1984	OM 314.944 D	<b>131</b>	1417 AK	01.1994 → 09.1996	OM 357.915 D	<b>190</b>
LPK 709	11.1977 → 12.1984	OM 314.964 D	<b>131</b>	1417 K	07.1989 → 08.1994	OM 366.952 D	<b>195</b>
LPK 709	11.1977 → 12.1984	OM 314.965 D	<b>131</b>	1417 K	07.1992 → 09.1996	OM 356.943 D	<b>190</b>
LPK 808	10.1969 → 10.1977	OM 314.910 D	<b>131</b>	1417 K	01.1994 → 09.1996	OM 357.915 D	<b>190</b>
LPK 808	10.1969 → 10.1977	OM 314.946 D	<b>131</b>	1420 AK	05.1992 → 09.1996	OM 356.987 D	<b>190</b>
LPK 808	10.1969 → 10.1977	OM 314.964 D	<b>131</b>	1420 LS	02.1990 → 09.1996	OM 356.984 D	<b>190</b>
LPK 808	10.1969 → 10.1977	OM 314.965 D	<b>131</b>	1420 LS	05.1992 → 09.1996	OM 356.987 D	<b>190</b>
LPK 809	11.1977 → 12.1984	OM 314.910 D	<b>131</b>	1420,1420 L	02.1990 → 09.1996	OM 356.984 D	<b>190</b>
LPK 809	11.1977 → 12.1984	OM 314.944 D	<b>131</b>	1420,1420 L	05.1992 → 09.1996	OM 356.987 D	<b>190</b>
LPK 809	11.1977 → 12.1984	OM 314.964 D	<b>131</b>	1422	02.1993 → 08.1994	OM 401.979 D	<b>336</b>
LPK 809	11.1977 → 12.1984	OM 314.965 D	<b>131</b>	1422 S,1422 LS	06.1989 → 08.1994	OM 441.905 D	<b>503</b>
LPK 811	03.1973 → 12.1984	OM 353.903 D	<b>129</b>	1422 S,1422 LS	06.1989 → 08.1994	OM 441.923 D	<b>503</b>
LPK 813	03.1973 → 12.1984	OM 353.904 D	<b>130</b>	1422,1422 L	06.1989 → 08.1994	OM 441.905 D	<b>503</b>
LPK 813	03.1973 → 12.1984	OM 353.981 D	<b>139</b>	1422,1422 L	06.1989 → 08.1994	OM 441.923 D	<b>503</b>
LPK 813	04.1976 → 12.1984	OM 353.982 D	<b>139</b>	1424	01.1994 → 09.1996	OM 357.946 D	<b>197</b>
LPK 813	04.1979 → 12.1984	OM 353.965 D	<b>130</b>	1424 S,1424 LS	12.1987 → 09.1996	OM 401.994 D	<b>336</b>
LPK 913	12.1969 → 12.1984	OM 353.904 D	<b>130</b>	1424 S,1424 LS	07.1992 → 08.1994	OM 401.977 D	<b>336</b>



			Pos				Pos		
1424 S,1424 LS	02.1993 → 09.1996	OM 401.973	D	336	1726,1726 L, 1726 LL	12.1988 → 08.1994	OM 442.914	D	504
1424 S,1424 LS	02.1993 → 09.1996	OM 401.975	D	336	1726,1726 L, 1726 LL	12.1988 → 08.1994	OM 442.923	D	504
1424 S,1424 LS	01.1995 → 09.1996	OM 445.924	D	372	1726,1726 L, 1726 LL	12.1988 → 08.1994	OM 442.932	D	504
1424 S,1424 LS	01.1995 → 09.1996	OM 445.926	D	372	1726,1726 L, 1726 LL	06.1989 → 08.1994	OM 442.922	D	504
1424 S,1424 LS	01.1995 → 09.1996	OM 445.938	D	372	1727 L	02.1990 → 08.1994	OM 401.973	D	336
1424,1424 L	12.1987 → 09.1996	OM 401.994	D	336	1727 L	07.1992 → 08.1994	OM 401.978	D	336
1424,1424 L	02.1993 → 09.1996	OM 401.973	D	336	1729	07.1988 → 08.1994	OM 442.906	D	504
1424,1424 L	02.1993 → 09.1996	OM 401.975	D	336	1729	07.1988 → 08.1994	OM 442.907	D	504
1424,1424 L	01.1995 → 09.1996	OM 445.924	D	372	1729	07.1988 → 08.1994	OM 442.923	D	504
1424,1424 L	01.1995 → 09.1996	OM 445.926	D	372	1729 LS	07.1988 → 08.1994	OM 442.907	D	504
1424,1424 L	01.1995 → 09.1996	OM 445.938	D	372	1733 S,1733 LS	01.1989 → 07.1992	OM 441.960	D	404
1426 S,1426 LS	06.1989 → 09.1993	OM 442.914	D	504	1733 S,1733 LS	01.1989 → 07.1992	OM 441.962	D	404
1426 S,1426 LS	06.1989 → 09.1993	OM 442.932	D	504	1733 S,1733 LS	01.1989 → 07.1992	OM 441.983	D	404
1427	02.1993 → 09.1996	OM 401.973	D	336	1733 S,1733 LS	05.1989 → 07.1992	OM 441.981	D	404
1427 L	02.1990 → 09.1996	OM 401.973	D	336	1733,1733 L, 1734 L	01.1989 → 07.1992	OM 441.960	D	404
1427 LS	01.1994 → 09.1996	OM 445.926	D	372	1733,1733 L, 1734 L	01.1989 → 07.1992	OM 441.962	D	404
1427 S, 1427 LS	02.1993 → 09.1996	OM 401.973	D	336	1733,1733 L, 1734 L	01.1989 → 07.1992	OM 441.983	D	404
1431	07.1988 → 08.1994	OM 401.979	D	336	1733,1733 L, 1734 L	05.1989 → 07.1992	OM 441.981	D	404
1431	07.1988 → 08.1994	OM 442.907	D	504	1733,1733 L, 1734 L	01.1991 → 09.1996	OM 441.986	D	418
1624 S	06.1992 → 09.1996	OM 401.975	D	336	1733,1733 L, 1734 L	01.1991 → 09.1996	OM 441.989	D	418
1624 S	01.1994 → 09.1996	OM 445.924	D	372	1733,1733 L, 1734 L	01.1994 → 09.1996	OM 445.920	D	372
1717 AK	09.1989 → 08.1994	OM 356.940	D	190	1733,1733 L, 1734 L	01.1994 → 09.1996	OM 445.939	D	372
1717 AK	09.1989 → 08.1994	OM 366.952	D	195	1820 AK	07.1993 → 09.1996	OM 356.987	D	190
1717 K	09.1989 → 08.1994	OM 356.940	D	190	1820 AK	01.1994 → 09.1996	OM 357.925	D	190
1717 K	09.1989 → 08.1994	OM 366.952	D	195	1820 K	05.1992 → 09.1996	OM 356.987	D	190
1717,1717 L	09.1989 → 08.1993	OM 356.940	D	190	1820 K	01.1994 → 09.1996	OM 357.925	D	190
1717,1717 L	09.1989 → 08.1994	OM 366.952	D	195	1820,1820 L	12.1987 → 09.1996	M 376.923	G	182
1720 L	12.1988 → 08.1994	OM 441.916	D	503	1820,1820 L	12.1987 → 09.1996	M 376.924	G	182
1720 L	12.1988 → 08.1994	OM 441.932	D	503	1820,1820 L	01.1991 → 09.1996	OM 356.984	D	190
1720 L	09.1989 → 08.1994	OM 441.920	D	503	1820,1820 L	05.1992 → 09.1996	OM 356.987	D	190
1720 S	02.1990 → 08.1994	OM 356.984	D	190	1820,1820 L	01.1994 → 09.1996	OM 357.925	D	190
1720,1720 L	12.1987 → 03.1991	OM 366.983	D	190	1824	12.1988 → 08.1994	OM 442.907	D	504
1720,1720 L	12.1987 → 09.1996	M 376.923	G	182	1824	08.1992 → 09.1996	OM 401.975	D	336
1720,1720 L	02.1990 → 08.1994	OM 356.984	D	190	1824	01.1994 → 09.1996	OM 445.924	D	372
1720,1720 L	01.1991 → 09.1996	OM 356.985	D	190	1824	01.1994 → 09.1996	OM 445.938	D	372
1722	09.1989 → 08.1994	OM 441.920	D	503	1824 AK	08.1992 → 09.1996	OM 356.999	D	197
1722 AK	12.1988 → 08.1994	OM 356.999	D	197	1824 AK	08.1992 → 09.1996	OM 401.984	D	336
1722 AK	12.1988 → 08.1994	OM 441.933	D	503	1824 AK	08.1992 → 09.1996	OM 401.990	D	336
1722 AK	08.1989 → 08.1994	OM 441.914	D	503	1824 AK	01.1994 → 09.1996	OM 445.925	D	372
1722 AK	08.1989 → 08.1994	OM 441.926	D	503	1824 AK	01.1994 → 09.1996	OM 445.930	D	372
1722 K	12.1988 → 08.1994	OM 401.979	D	336	1824 K	08.1992 → 09.1996	OM 401.975	D	336
1722 K	12.1988 → 08.1994	OM 441.905	D	503	1824 K	01.1994 → 09.1996	OM 445.924	D	372
1722 K	12.1988 → 08.1994	OM 441.916	D	503	1824 K	01.1994 → 09.1996	OM 445.938	D	372
1722 K	12.1988 → 08.1994	OM 441.923	D	503	1824,1824 L	01.1994 → 09.1996	OM 445.924	D	372
1722 K	07.1989 → 09.1993	OM 441.913	D	503	1824,1824 L	01.1994 → 09.1996	OM 445.938	D	372
1722 K	08.1989 → 08.1994	OM 441.914	D	503	1824,1824 L	01.1994 → 09.1996	OM 445.941	D	372
1722 K	09.1989 → 08.1994	OM 441.920	D	503	1827 AK	08.1992 → 09.1996	OM 401.973	D	336
1722,1722 L, 1722 LL	12.1988 → 08.1994	OM 441.905	D	503	1827 AK	08.1992 → 09.1996	OM 401.989	D	336
1722,1722 L, 1722 LL	12.1988 → 08.1994	OM 441.916	D	503	1827 AK	08.1992 → 09.1996	OM 445.933	D	372
1722,1722 L, 1722 LL	12.1988 → 08.1994	OM 441.923	D	503	1827 K	01.1994 → 09.1996	OM 445.926	D	372
1722,1722 L, 1722 LL	12.1988 → 08.1994	OM 441.932	D	503	1827 S,1827 LS	12.1990 → 09.1996	OM 401.973	D	336
1722,1722 L, 1722 LL	07.1989 → 09.1993	OM 441.913	D	503	1827 S,1827 LS	07.1992 → 08.1994	OM 401.977	D	336
1722,1722 L, 1722 LL	08.1989 → 08.1994	OM 441.914	D	503	1827 S,1827 LS	02.1993 → 09.1996	OM 401.991	D	336
1722,1722 L, 1722 LL	09.1989 → 08.1994	OM 441.920	D	503	1827 S,1827 LS	01.1994 → 09.1996	OM 445.926	D	372
1726 AK	06.1989 → 08.1994	OM 442.922	D	504	1827 S,1827 LS	01.1994 → 09.1996	OM 445.936	D	372
1726 AK	06.1989 → 08.1994	OM 442.935	D	504	1827,1827 L	12.1990 → 09.1996	OM 401.973	D	336
1726 K	12.1988 → 08.1994	OM 440.909	D	504	1827,1827 L	07.1992 → 08.1994	OM 401.977	D	336
1726 K	12.1988 → 08.1994	OM 442.914	D	504	1827,1827 L	02.1993 → 09.1996	OM 401.991	D	336
1726 K	12.1988 → 08.1994	OM 442.932	D	504	1827,1827 L	01.1994 → 09.1996	OM 445.926	D	372
1726 K	06.1989 → 08.1994	OM 442.922	D	504	1827,1827 L	01.1994 → 09.1996	OM 445.936	D	372
1726 LL	02.1990 → 09.1996	OM 401.973	D	336	1831 K	12.1988 → 08.1994	OM 401.979	D	336
1726 LL	07.1992 → 09.1996	OM 401.978	D	336	1831 K	10.1990 → 08.1994	OM 402.987	D	338
1726 S,1726 LS	12.1988 → 08.1994	OM 442.907	D	504	1831 S,1831 LS	12.1987 → 09.1996	OM 401.993	D	336
1726 S,1726 LS	12.1988 → 08.1994	OM 442.914	D	504	1831 S,1831 LS	12.1990 → 09.1996	OM 401.972	D	336
1726 S,1726 LS	12.1988 → 08.1994	OM 442.932	D	504	1831 S,1831 LS	12.1990 → 09.1996	OM 401.979	D	336
1726 S,1726 LS	06.1989 → 08.1994	OM 442.922	D	504	1831 S,1831 LS	01.1994 → 09.1996	OM 445.929	D	372
1726,1726 L, 1726 LL	12.1988 → 08.1994	OM 442.906	D	504	1831 S,1831 LS	01.1994 → 09.1996	OM 445.937	D	372
1726,1726 L, 1726 LL	12.1988 → 08.1994	OM 442.907	D	504	1831,1831 L	12.1990 → 09.1996	OM 401.972	D	336
1726,1726 L, 1726 LL	12.1988 → 08.1994	OM 442.909	D	504	1831,1831 L	12.1990 → 09.1996	OM 401.979	D	336

M

		Pos			Pos		
1831,1831 L	12.1990 → 09.1996	OM 401.993 D	<b>336</b>	2429	07.1988 → 08.1994	OM 442.909 D	<b>504</b>
1831,1831 L	01.1994 → 09.1996	OM 445.929 D	<b>372</b>	2429	07.1988 → 08.1994	OM 442.909 D	<b>504</b>
1831,1831 L	01.1994 → 09.1996	OM 445.937 D	<b>372</b>	2429	07.1988 → 08.1994	OM 442.923 D	<b>504</b>
1834 S,1834 LS	01.1991 → 09.1996	OM 441.986 D	<b>418</b>	2429	07.1988 → 08.1994	OM 442.923 D	<b>504</b>
1834 S,1834 LS	01.1991 → 09.1996	OM 441.989 D	<b>418</b>	2431	12.1987 → 09.1996	OM 401.993 D	<b>336</b>
1834 S,1834 LS	01.1994 → 09.1996	OM 445.920 D	<b>372</b>	2431	12.1987 → 09.1996	OM 401.993 D	<b>336</b>
1834 S,1834 LS	01.1994 → 09.1996	OM 445.939 D	<b>372</b>	2431	12.1987 → 09.1996	OM 401.993 D	<b>336</b>
1834,1834 L	01.1991 → 09.1996	OM 441.986 D	<b>418</b>	2431	07.1988 → 09.1996	OM 401.979 D	<b>336</b>
1834,1834 L	01.1991 → 09.1996	OM 441.989 D	<b>418</b>	2431	07.1988 → 09.1996	OM 401.979 D	<b>336</b>
1834,1834 L	03.1991 → 09.1996	OM 441.987 D	<b>418</b>	2431	07.1988 → 09.1996	OM 401.979 D	<b>336</b>
1834,1834 L	03.1991 → 09.1996	OM 441.991 D	<b>418</b>	2431	12.1990 → 09.1996	OM 401.972 D	<b>336</b>
1834,1834 L	01.1994 → 09.1996	OM 445.920 D	<b>372</b>	2431	12.1990 → 09.1996	OM 401.972 D	<b>336</b>
1834,1834 L	01.1994 → 09.1996	OM 445.921 D	<b>372</b>	2431	12.1990 → 09.1996	OM 401.972 D	<b>336</b>
1834,1834 L	01.1994 → 09.1996	OM 445.939 D	<b>372</b>	2431	01.1994 → 09.1996	OM 445.929 D	<b>372</b>
1926	12.1988 → 08.1994	OM 442.914 D	<b>504</b>	2431	01.1994 → 09.1996	OM 445.937 D	<b>372</b>
1926	12.1988 → 08.1994	OM 442.932 D	<b>504</b>	2433 K	09.1989 → 07.1992	OM 441.960 D	<b>404</b>
1926	06.1989 → 08.1994	OM 442.922 D	<b>504</b>	2433 K	09.1989 → 07.1992	OM 441.981 D	<b>404</b>
2320 L	02.1990 → 08.1994	OM 356.984 D	<b>190</b>	2433 L	07.1988 → 09.1996	OM 401.979 D	<b>336</b>
2320 L	05.1992 → 09.1996	OM 356.987 D	<b>190</b>	2433 L	12.1988 → 08.1994	OM 441.960 D	<b>404</b>
2327 L	02.1990 → 09.1996	OM 401.973 D	<b>336</b>	2433 S	12.1988 → 08.1994	OM 441.960 D	<b>404</b>
2327 L	01.1994 → 09.1996	OM 445.926 D	<b>372</b>	2433 S	05.1989 → 07.1992	OM 441.981 D	<b>404</b>
2420,2420 L	02.1990 → 03.1991	OM 366.983 D	<b>190</b>	2433 S	01.1991 → 09.1996	OM 441.986 D	<b>418</b>
2420,2420 L	02.1990 → 03.1991	OM 366.983 D	<b>190</b>	2433 S	01.1991 → 09.1996	OM 441.989 D	<b>418</b>
2420,2420 L	02.1990 → 08.1994	OM 356.984 D	<b>190</b>	2433 S,2433 LS	05.1989 → 07.1992	OM 441.960 D	<b>404</b>
2420,2420 L	02.1990 → 09.1996	OM 356.984 D	<b>190</b>	2433 S,2433 LS	05.1989 → 07.1992	OM 441.962 D	<b>404</b>
2422	09.1989 → 08.1994	OM 441.923 D	<b>503</b>	2433 S,2433 LS	05.1989 → 07.1992	OM 441.981 D	<b>404</b>
2422 K	09.1989 → 08.1994	OM 441.905 D	<b>503</b>	2433 S,2433 LS	05.1989 → 07.1992	OM 441.983 D	<b>404</b>
2422 K	09.1989 → 08.1994	OM 441.912 D	<b>503</b>	2433,2433 L, 2434 L	05.1989 → 07.1992	OM 441.960 D	<b>404</b>
2422 K	09.1989 → 08.1994	OM 441.923 D	<b>503</b>	2433,2433 L, 2434 L	05.1989 → 07.1992	OM 441.962 D	<b>404</b>
2422 K	09.1989 → 08.1994	OM 441.924 D	<b>503</b>	2433,2433 L, 2434 L	05.1989 → 07.1992	OM 441.981 D	<b>404</b>
2422 L	12.1988 → 08.1994	OM 441.905 D	<b>503</b>	2433,2433 L, 2434 L	05.1989 → 07.1992	OM 441.983 D	<b>404</b>
2422 L	12.1988 → 08.1994	OM 441.923 D	<b>503</b>	2433,2433 L, 2434 L	01.1991 → 09.1996	OM 441.986 D	<b>418</b>
2422 L	09.1989 → 08.1994	OM 441.920 D	<b>503</b>	2433,2433 L, 2434 L	01.1991 → 09.1996	OM 441.989 D	<b>418</b>
2422, 2422 L	09.1989 → 08.1994	OM 441.916 D	<b>503</b>	2433,2433 L, 2434 L	01.1994 → 09.1996	OM 445.920 D	<b>372</b>
2422, 2422 L	09.1989 → 08.1994	OM 441.920 D	<b>503</b>	2433,2433 L, 2434 L	01.1994 → 09.1996	OM 445.939 D	<b>372</b>
2422, 2422 L	09.1989 → 08.1994	OM 441.932 D	<b>503</b>	2522 L	12.1988 → 08.1994	OM 441.905 D	<b>503</b>
2422, 2422 L	09.1989 → 08.1994	OM 441.905 D	<b>503</b>	2522 L	09.1989 → 08.1994	OM 441.920 D	<b>503</b>
2422, 2422 L	09.1989 → 08.1994	OM 441.905 D	<b>503</b>	2524	06.1992 → 09.1996	OM 401.975 D	<b>336</b>
2422, 2422 L	09.1989 → 08.1994	OM 441.920 D	<b>503</b>	2524	01.1994 → 09.1996	OM 445.924 D	<b>372</b>
2422, 2422 L	09.1989 → 08.1994	OM 441.920 D	<b>503</b>	2524 K	06.1992 → 09.1996	OM 401.975 D	<b>336</b>
2422, 2422 L	09.1989 → 08.1994	OM 441.923 D	<b>503</b>	2524 K	01.1994 → 09.1996	OM 445.924 D	<b>372</b>
2422, 2422 L	09.1989 → 08.1994	OM 441.923 D	<b>503</b>	2524 L	06.1992 → 09.1996	OM 401.975 D	<b>336</b>
2422, 2422 L	09.1989 → 08.1994	OM 441.924 D	<b>503</b>	2524 L	01.1994 → 09.1996	OM 445.924 D	<b>372</b>
2422, 2422 L	09.1989 → 08.1994	OM 441.924 D	<b>503</b>	2524 L	01.1994 → 09.1996	OM 445.938 D	<b>372</b>
2426	12.1988 → 08.1994	OM 442.914 D	<b>504</b>	2524 L	01.1994 → 09.1996	OM 445.941 D	<b>372</b>
2426	12.1988 → 08.1994	OM 442.932 D	<b>504</b>	2524,2524 L	12.1987 → 09.1996	OM 355.975-005 D	<b>408</b>
2426	06.1989 → 08.1994	OM 442.922 D	<b>504</b>			(AFS)	
2426	01.1990 → 08.1994	OM 442.914 D	<b>504</b>	2524,2524 L	12.1987 → 09.1996	OM 355.975-006 D	<b>408</b>
2426	01.1990 → 08.1994	OM 442.921 D	<b>504</b>			(AFS)	
2426	01.1990 → 08.1994	OM 442.932 D	<b>504</b>	2524,2524 L	12.1987 → 09.1996	OM 355.976-001 D	<b>376</b>
2426	01.1990 → 08.1994	OM 442.934 D	<b>504</b>			(AFS)	
2426	01.1990 → 08.1994	OM 462.900-011 D	<b>508</b>	2524,2524 L	12.1987 → 09.1996	OM 355.976-002 D	<b>376</b>
		(AFS)				(AFS)	
2426	01.1990 → 08.1994	OM 462.900-013 D	<b>508</b>	2524,2524 L	12.1987 → 09.1996	OM 355.976-003 D	<b>376</b>
		(AFS)				(AFS)	
2426 L	12.1988 → 08.1994	OM 442.914 D	<b>504</b>	2524,2524 L	12.1987 → 09.1996	OM 355.976-004 D	<b>376</b>
2426 L	12.1988 → 08.1994	OM 442.932 D	<b>504</b>			(AFS)	
2426 L	02.1990 → 08.1994	OM 401.973 D	<b>336</b>	2524,2524 L	12.1987 → 09.1996	OM 355.976-007 D	<b>376</b>
2426 L	02.1990 → 08.1994	OM 401.979 D	<b>336</b>			(AFS)	
2426 L	02.1990 → 08.1994	OM 441.960 D	<b>404</b>	2524,2524 L	12.1987 → 09.1996	OM 496.900-001 D	<b>323</b>
2426 L	02.1990 → 08.1994	OM 442.914 D	<b>504</b>			(AFS)	
2426, 2426 L	02.1990 → 08.1994	OM 442.922 D	<b>504</b>	2524,2524 L	12.1987 → 09.1996	OM 496.900-003 D	<b>323</b>
2426, 2426 L	02.1990 → 08.1994	OM 442.932 D	<b>504</b>			(AFS)	
2426, 2426 L	02.1990 → 08.1994	OM 442.932 D	<b>504</b>	2524,2524 L	12.1987 → 09.1996	OM 496.900-026 D	<b>323</b>
2427 L	02.1990 → 09.1996	OM 401.973 D	<b>336</b>			(AFS)	
2427 L	07.1992 → 08.1994	OM 401.977 D	<b>336</b>	2524,2524 L	12.1987 → 09.1996	OM 496.900-027 D	<b>323</b>
2429	07.1988 → 08.1994	OM 442.906 D	<b>504</b>			(AFS)	
2429	07.1988 → 08.1994	OM 442.906 D	<b>504</b>	2524,2524 L	06.1992 → 09.1996	OM 401.973 D	<b>336</b>
2429	07.1988 → 08.1994	OM 442.907 D	<b>504</b>	2524,2524 L	06.1992 → 09.1996	OM 401.973 D	<b>336</b>
2429	07.1988 → 08.1994	OM 442.907 D	<b>504</b>	2524,2524 L	06.1992 → 09.1996	OM 401.975 D	<b>336</b>

				Pos					Pos
2524,2524 L	06.1992 → 09.1996	OM 401.975	D	<b>336</b>	1013 K	02.1976 → 12.1984	OM 353.943	D	<b>130</b>
2524,2524 L	01.1994 → 09.1996	OM 445.924	D	<b>372</b>	1013 K	02.1976 → 12.1984	OM 353.945	D	<b>130</b>
2524,2524 L	01.1994 → 09.1996	OM 445.924	D	<b>372</b>	1013 K	02.1976 → 12.1984	OM 353.946	D	<b>130</b>
2527	10.1993 → 09.1996	OM 401.973	D	<b>336</b>	1013 S	02.1976 → 12.1984	OM 353.942	D	<b>130</b>
2527	01.1994 → 09.1996	OM 445.926	D	<b>372</b>	1013 S	02.1976 → 12.1984	OM 353.943	D	<b>130</b>
2527 K	10.1993 → 09.1996	OM 401.973	D	<b>336</b>	1013 S	02.1976 → 12.1984	OM 353.946	D	<b>130</b>
2527 K	01.1994 → 09.1996	OM 445.926	D	<b>372</b>	1017	11.1975 → 02.1991	OM 352.900-016	D	<b>135</b>
2527 L	02.1990 → 09.1996	OM 401.973	D	<b>336</b>	1017	11.1975 → 02.1991	OM 353.950	D	<b>141</b>
2527 L	03.1991 → 08.1994	OM 442.914	D	<b>504</b>	1017	11.1975 → 02.1991	OM 353.952	D	<b>141</b>
2527 L	07.1992 → 08.1994	OM 401.977	D	<b>336</b>	1017	11.1975 → 02.1991	OM 353.953	D	<b>141</b>
2527 L	09.1992 → 08.1994	OM 401.977	D	<b>336</b>	1017	11.1975 → 02.1991	OM 353.975	D	<b>156</b>
2527 L	09.1992 → 09.1996	OM 401.973	D	<b>336</b>	1017	11.1975 → 02.1991	OM 390.900-513	D	<b>189</b>
2527 L	09.1992 → 09.1996	OM 401.979	D	<b>336</b>	1017	11.1975 → 02.1991	OM 390.900-519	D	<b>189</b>
2527 L	02.1993 → 09.1996	OM 401.991	D	<b>336</b>	1017 A	11.1975 → 02.1991	OM 353.950	D	<b>141</b>
2527 L	01.1994 → 09.1996	OM 445.926	D	<b>372</b>	1017 A	11.1975 → 02.1991	OM 353.952	D	<b>141</b>
2527 L	01.1994 → 09.1996	OM 445.926	D	<b>372</b>	1017 A	11.1975 → 02.1991	OM 353.953	D	<b>141</b>
2527 L	01.1994 → 09.1996	OM 445.929	D	<b>372</b>	1017 AK	02.1976 → 12.1984	OM 353.950	D	<b>141</b>
2527 L	01.1994 → 09.1996	OM 445.936	D	<b>372</b>	1017 AS	04.1977 → 09.1985	OM 353.950	D	<b>141</b>
2527 L	01.1994 → 09.1996	OM 445.936	D	<b>372</b>	1017 K	02.1976 → 12.1984	OM 353.950	D	<b>141</b>
2527 L	01.1994 → 09.1996	OM 445.940	D	<b>372</b>	1017 S,1017 LS	10.1976 → 12.1984	OM 353.970	D	<b>141</b>
2531 L	12.1987 → 09.1996	OM 401.993	D	<b>336</b>	1017 S,1017 LS	02.1977 → 12.1984	OM 353.971	D	<b>141</b>
2531 L	07.1988 → 09.1996	OM 401.979	D	<b>336</b>	1019 AF	01.1979 → 12.1982	OM 401.919	D	<b>325</b>
2531 L	07.1988 → 09.1996	OM 401.979	D	<b>336</b>	1019 AF	01.1979 → 12.1982	OM 401.922	D	<b>325</b>
2531 L	12.1990 → 09.1996	OM 401.972	D	<b>336</b>	1019 AF	01.1979 → 12.1982	OM 401.924	D	<b>325</b>
2531 L	01.1994 → 09.1996	OM 445.920	D	<b>372</b>	1019 F	01.1979 → 12.1982	OM 401.919	D	<b>325</b>
2531 L	01.1994 → 09.1996	OM 445.929	D	<b>372</b>	1019 F	01.1979 → 12.1982	OM 401.922	D	<b>325</b>
2531 L	01.1994 → 09.1996	OM 445.937	D	<b>372</b>	1213	09.1975 → 05.1986	OM 353.943	D	<b>130</b>
2531,2531 L	12.1987 → 09.1996	OM 401.993	D	<b>336</b>	1213	09.1975 → 05.1986	OM 353.944	D	<b>130</b>
2531,2531 L	12.1990 → 09.1996	OM 401.972	D	<b>336</b>	1213	09.1975 → 05.1986	OM 396.900-008	D	<b>148</b>
2531,2531 L	12.1990 → 09.1996	OM 401.972	D	<b>336</b>	1213	09.1975 → 05.1986	(AFS)		
2531,2531 L	12.1990 → 09.1996	OM 401.979	D	<b>336</b>	1213	09.1975 → 05.1986	OM 396.900-020	D	<b>148</b>
2531,2531 L	12.1990 → 09.1996	OM 401.979	D	<b>336</b>	1213	09.1975 → 05.1986	(AFS)		
2531,2531 L	12.1990 → 09.1996	OM 401.993	D	<b>336</b>	1213	09.1975 → 05.1986	OM 396.900-022	D	<b>154</b>
2531,2531 L	01.1994 → 09.1996	OM 445.929	D	<b>372</b>	1213	02.1976 → 12.1984	(AFS)		
2531,2531 L	01.1994 → 09.1996	OM 445.929	D	<b>372</b>	1213	02.1976 → 12.1984	OM 353.945	D	<b>130</b>
2531,2531 L	01.1994 → 09.1996	OM 445.937	D	<b>372</b>	1213	02.1976 → 12.1984	OM 353.946	D	<b>130</b>
2531,2531 L	01.1994 → 09.1996	OM 445.937	D	<b>372</b>	1213 A	09.1975 → 05.1986	OM 353.943	D	<b>130</b>
2534 K	01.1991 → 09.1996	OM 441.986	D	<b>418</b>	1213 A	09.1975 → 05.1986	OM 353.944	D	<b>130</b>
2534 K	01.1991 → 09.1996	OM 441.989	D	<b>418</b>	1213 A	02.1976 → 12.1984	OM 353.945	D	<b>130</b>
2534 K	01.1994 → 09.1996	OM 445.920	D	<b>372</b>	1213 A	02.1976 → 12.1984	OM 353.946	D	<b>130</b>
2534 L	07.1988 → 09.1996	OM 401.979	D	<b>336</b>	1213 AK	09.1975 → 05.1986	OM 353.943	D	<b>130</b>
2534 L	01.1994 → 09.1996	OM 445.920	D	<b>372</b>	1213 AK	09.1975 → 05.1986	OM 353.944	D	<b>130</b>
2534 S,2534 LS	01.1991 → 09.1996	OM 441.986	D	<b>418</b>	1213 AK	02.1976 → 12.1984	OM 353.945	D	<b>130</b>
2534 S,2534 LS	03.1991 → 09.1996	OM 441.987	D	<b>418</b>	1213 AK	02.1976 → 12.1984	OM 353.946	D	<b>130</b>
2534 S,2534 LS	01.1994 → 09.1996	OM 445.920	D	<b>372</b>	1213 AS	09.1975 → 05.1986	OM 353.943	D	<b>130</b>
2534 S,2534 LS	01.1994 → 09.1996	OM 445.921	D	<b>372</b>	1213 AS	09.1975 → 05.1986	OM 353.944	D	<b>130</b>
2534 S,2534 LS	01.1994 → 09.1996	OM 445.922	D	<b>372</b>	1213 AS	02.1976 → 12.1984	OM 353.945	D	<b>130</b>
2534,2534 L	01.1991 → 09.1996	OM 441.986	D	<b>418</b>	1213 AS	02.1976 → 12.1984	OM 353.946	D	<b>130</b>
2534,2534 L	01.1991 → 09.1996	OM 441.989	D	<b>418</b>	1213 K	09.1975 → 05.1986	OM 353.943	D	<b>130</b>
2534,2534 L	03.1991 → 09.1996	OM 441.987	D	<b>418</b>	1213 K	09.1975 → 05.1986	OM 353.944	D	<b>130</b>
2534,2534 L	03.1991 → 09.1996	OM 441.991	D	<b>418</b>	1213 K	02.1976 → 12.1984	OM 353.945	D	<b>130</b>
2534,2534 L	01.1994 → 09.1996	OM 445.920	D	<b>372</b>	1213 K	02.1976 → 12.1984	OM 353.946	D	<b>130</b>
2534,2534 L	01.1994 → 09.1996	OM 445.921	D	<b>372</b>	1213 S	09.1975 → 05.1986	OM 353.943	D	<b>130</b>
2534,2534 L	01.1994 → 09.1996	OM 445.922	D	<b>372</b>	1213 S	09.1975 → 05.1986	OM 353.944	D	<b>130</b>
3231 L	07.1988 → 09.1996	OM 401.979	D	<b>336</b>	1213 S	02.1976 → 12.1984	OM 353.945	D	<b>130</b>
3231 L	12.1990 → 09.1996	OM 401.972	D	<b>336</b>	1213 S	02.1976 → 12.1984	OM 353.946	D	<b>130</b>
3231 L	06.1992 → 09.1996	OM 401.993	D	<b>336</b>	1217 A	09.1975 → 07.1985	OM 353.951	D	<b>141</b>
3231 L	01.1994 → 09.1996	OM 445.929	D	<b>372</b>	1217 A	09.1975 → 09.1985	OM 353.950	D	<b>141</b>
NG					1217 A	09.1975 → 09.1985	OM 353.953	D	<b>141</b>
1013	02.1976 → 12.1984	OM 344.964 (USA)	D	<b>157</b>	1217 A	11.1975 → 09.1985	OM 353.952	D	<b>141</b>
1013	02.1976 → 12.1984	OM 353.942	D	<b>130</b>	1217 AK	09.1975 → 07.1985	OM 353.951	D	<b>141</b>
1013	02.1976 → 12.1984	OM 353.943	D	<b>130</b>	1217 AK	09.1975 → 09.1985	OM 353.950	D	<b>141</b>
1013 A	02.1976 → 12.1984	OM 353.942	D	<b>130</b>	1217 AS	09.1975 → 07.1985	OM 353.951	D	<b>141</b>
1013 A	02.1976 → 05.1986	OM 353.943	D	<b>130</b>	1217 AS	09.1975 → 09.1985	OM 353.950	D	<b>141</b>
1013 AK	02.1976 → 12.1984	OM 353.942	D	<b>130</b>	1217 AS	09.1975 → 09.1985	OM 353.953	D	<b>141</b>
1013 AK	02.1976 → 12.1984	OM 353.943	D	<b>130</b>	1217 AS	11.1975 → 09.1985	OM 353.952	D	<b>141</b>
1013 AK	02.1976 → 12.1984	OM 353.945	D	<b>130</b>	1217 CA	05.1982 → 10.1990	OM 366.960	D	<b>200</b>
1013 AK	02.1976 → 12.1984	OM 353.946	D	<b>130</b>	1217 K	09.1975 → 12.1984	OM 353.950	D	<b>141</b>
1013 K	02.1976 → 12.1984	OM 353.942	D	<b>130</b>	1217 K	09.1975 → 12.1984	OM 353.951	D	<b>141</b>

M



		Pos			Pos		
1217 S,1217 LS	09.1975 → 07.1985	OM 353.951 D	141	1417 CA	04.1984 → 03.1991	OM 366.951 D	195
1217 S,1217 LS	09.1975 → 09.1985	OM 353.950 D	141	1417 CA	06.1984 → 03.1991	OM 366.952 D	195
1217 S,1217 LS	09.1975 → 09.1985	OM 353.953 D	141	1417 CAK	04.1984 → 03.1991	OM 366.951 D	195
1217 S,1217 LS	11.1975 → 09.1985	OM 353.952 D	141	1417 CAK	06.1984 → 03.1991	OM 366.952 D	195
1217,1217 L	08.1973 → 09.1996	OM 352.900-016 D	135	1417 CK	04.1984 → 03.1991	OM 366.951 D	195
1217,1217 L	08.1973 → 09.1996	OM 390.900-510 D	189	1417 CK	06.1984 → 03.1991	OM 366.952 D	195
1217,1217 L	08.1973 → 09.1996	OM 390.900-513 D	189	1417 K	05.1975 → 12.1984	OM 353.951 D	141
1217,1217 L	08.1973 → 09.1996	OM 390.900-516 D	189	1417 K	02.1977 → 12.1984	OM 353.971 D	141
1217,1217 L	08.1973 → 09.1996	OM 390.900-522 D	189	1419 AK	05.1975 → 12.1984	OM 401.905 D	325
1217,1217 L	09.1975 → 07.1985	OM 353.951 D	141	1419 AS	05.1975 → 12.1982	OM 401.914 D	325
1217,1217 L	09.1975 → 09.1985	OM 353.950 D	141	1419 C,1419 CL	05.1983 → 06.1985	OM 362.906 D	170
1217,1217 L	09.1975 → 09.1985	OM 353.953 D	141	1419 C,1419 CL	05.1983 → 06.1985	OM 362.909 D	170
1217,1217 L	11.1975 → 09.1985	OM 353.952 D	141	1419 K	05.1975 → 12.1982	OM 401.905 D	325
1217,1217 L	10.1976 → 09.1985	OM 353.970 D	141	1419 S,1419 LS	05.1975 → 12.1982	OM 401.905 D	325
1217,1217 L	02.1977 → 07.1985	OM 353.971 D	141	1419,1419 L	08.1973 → 09.1996	OM 390.900-511 D	189
1219	09.1975 → 09.1984	OM 401.914 D	325	1419,1419 L	08.1973 → 09.1996	OM 390.900-517 D	189
1219	09.1975 → 09.1984	OM 401.915 D	325	1419,1419 L	08.1973 → 09.1996	OM 495.900-001 D	323
1219 A	09.1975 → 12.1982	OM 401.905 D	325			(AFS)	
1219 A	09.1975 → 12.1982	OM 401.906 D	325	1419,1419 L	08.1973 → 09.1996	OM 495.900-002 D	323
1219 AK	09.1975 → 12.1984	OM 401.905 D	325			(AFS)	
1219 K	09.1975 → 09.1984	OM 401.905 D	325	1419,1419 L	08.1973 → 09.1996	OM 495.900-009 D	323
1219 K	09.1975 → 09.1984	OM 401.906 D	325			(AFS)	
1219 S	09.1975 → 09.1984	OM 401.914 D	325	1419,1419 L	08.1973 → 09.1996	OM 495.900-010 D	323
1219 S	09.1975 → 09.1984	OM 401.915 D	325			(AFS)	
1222	07.1982 → 02.1990	OM 421.905 D	382	1419,1419 L	05.1975 → 12.1982	OM 401.914 D	325
1222	07.1982 → 02.1990	OM 421.909 D	373	1420 LS	07.1985 → 03.1991	OM 366.983 D	190
1222 A	05.1982 → 10.1990	OM 421.905 D	382	1420,1420 L	07.1985 → 03.1991	OM 366.983 D	190
1222 A	05.1982 → 10.1990	OM 421.909 D	373	1422 S, 1422 LS	10.1981 → 02.1993	OM 421.905 D	382
1222 S	07.1982 → 02.1990	OM 421.905 D	382	1422,1422 L	05.1982 → 10.1990	OM 421.905 D	382
1413	09.1975 → 12.1984	OM 353.944 D	130	1424 K	07.1975 → 01.1987	OM 402.910 D	327
1413	09.1975 → 12.1984	OM 396.900-008 D	148	1424 K	07.1975 → 01.1987	OM 402.911 D	327
		(AFS)		1424 S,1424 LS	05.1982 → 01.1987	OM 402.910 D	327
1413	09.1975 → 12.1984	OM 396.900-016 D	148	1424 S,1424 LS	05.1982 → 01.1987	OM 402.911 D	327
		(AFS)		1424,1424 L	07.1975 → 01.1987	OM 402.910 D	327
1413	02.1976 → 12.1984	OM 353.946 D	130	1424,1424 L	07.1975 → 01.1987	OM 402.911 D	327
1413 A	09.1975 → 12.1984	OM 353.944 D	130	1425 S,1425 LS	11.1982 → 03.1991	OM 422.909 D	370
1413 A	02.1976 → 12.1984	OM 353.946 D	130	1613 K	09.1975 → 12.1984	OM 353.944 D	130
1413 A	02.1977 → 12.1984	OM 353.964 D	130	1613 K	02.1976 → 12.1984	OM 353.946 D	130
1413 AK	09.1975 → 12.1984	OM 353.944 D	130	1613,1613 L	09.1975 → 12.1984	OM 353.944 D	130
1413 AK	02.1976 → 12.1984	OM 353.946 D	130	1613,1613 L	02.1976 → 12.1984	OM 353.946 D	130
1413 AK	02.1977 → 12.1984	OM 353.964 D	130	1614	04.1984 → 03.1991	OM 366.906 D	208
1413 K	09.1975 → 12.1984	OM 353.944 D	130	1614 K	04.1984 → 03.1991	OM 366.909 D	208
1413 K	02.1976 → 12.1984	OM 353.946 D	130	1617 AK	01.1975 → 07.1985	OM 353.951 D	141
1413 K	02.1977 → 12.1984	OM 353.964 D	130	1617 AK	01.1975 → 07.1985	OM 353.953 D	141
1414	04.1984 → 03.1991	OM 306.900-017 D	206	1617 AK	02.1977 → 07.1985	OM 353.971 D	141
		(ZA)		1617 C,1617 CL	04.1984 → 03.1991	OM 366.951 D	195
1414	04.1984 → 03.1991	OM 366.906 D	208	1617 C,1617 CL	06.1984 → 03.1991	OM 366.952 D	195
1414	04.1984 → 03.1991	OM 366.909 D	208	1617 CAK	04.1984 → 03.1991	OM 366.951 D	195
1414 K	04.1984 → 03.1991	OM 366.906 D	208	1617 CAK	06.1984 → 03.1991	OM 366.952 D	195
1414 K	04.1984 → 03.1991	OM 366.909 D	208	1617 CK	04.1984 → 03.1991	OM 366.951 D	195
1417	05.1975 → 12.1984	OM 352.900-016 D	135	1617 CS	04.1984 → 03.1991	OM 366.951 D	195
1417	05.1975 → 12.1984	OM 353.951 D	141	1617 K	01.1975 → 07.1985	OM 353.951 D	141
1417	05.1975 → 12.1984	OM 390.900-510 D	189	1617 K	01.1975 → 07.1985	OM 353.953 D	141
1417	05.1975 → 12.1984	OM 390.900-513 D	189	1617 K	02.1977 → 07.1985	OM 353.971 D	141
1417	05.1975 → 12.1984	OM 390.900-516 D	189	1617 S	01.1975 → 07.1985	OM 353.951 D	141
1417	05.1975 → 12.1984	OM 390.900-519 D	189	1617 S	01.1975 → 07.1985	OM 353.953 D	141
1417	05.1975 → 12.1984	OM 390.900-522 D	189	1617,1617 L	08.1973 → 09.1996	OM 352.900-016 D	135
1417	02.1977 → 12.1984	OM 353.971 D	141	1617,1617 L	08.1973 → 09.1996	OM 390.900-510 D	189
1417	01.1980 → 12.1984	OM 396.900-405 D	165	1617,1617 L	08.1973 → 09.1996	OM 390.900-516 D	189
		(AFS)		1617,1617 L	01.1975 → 07.1985	OM 353.951 D	141
1417	05.1988 → 12.1984	OM 306.900-413 D	227	1617,1617 L	01.1975 → 07.1985	OM 353.953 D	141
		(ZA)		1617,1617 L	05.1988 → 09.1996	OM 306.900-416 D	227
1417	03.1992 → 12.1984	OM 306.900-416 D	227			(ZA)	
		(ZA)		1617,1617 L	03.1992 → 09.1996	OM 306.900-413 D	227
1417 A	05.1975 → 12.1984	OM 353.951 D	141			(ZA)	
1417 A	02.1977 → 12.1984	OM 353.971 D	141	1619 AK	05.1975 → 12.1982	OM 401.905 D	325
1417 AK	05.1975 → 12.1984	OM 353.951 D	141	1619 C,1619 CL	06.1983 → 06.1985	OM 362.906 D	170
1417 AK	02.1977 → 12.1984	OM 353.971 D	141	1619 C,1619 CL	06.1983 → 06.1985	OM 362.909 D	170
1417 C	04.1984 → 03.1991	OM 366.951 D	195	1619 K	05.1975 → 12.1982	OM 401.905 D	325
1417 C	06.1984 → 03.1991	OM 366.952 D	195	1619 S	11.1974 → 12.1984	OM 401.914 D	325

			Pos				Pos
1619 S	05.1975 → 12.1984	OM 401.905 D	325	1635,1635 L	02.1986 → 07.1989	OM 442.952 D	390
1619,1619 L	08.1973 → 09.1996	OM 390.900-511 D	189	1636 S,1636 LS	12.1983 → 03.1991	OM 423.905 D	382
1619,1619 L	08.1973 → 09.1996	OM 390.900-517 D	189	1636 S,1636 LS	12.1983 → 03.1991	OM 423.908 D	382
1619,1619 L	08.1973 → 09.1996	OM 495.900-002 D	323	1636 S,1636 L	12.1983 → 03.1991	OM 423.905 D	382
		(AFS)		1636,1636 L	12.1983 → 03.1991	OM 423.908 D	382
1619,1619 L	11.1974 → 05.1987	OM 401.914 D	325	1638	11.1980 → 12.1986	OM 422.953 D	381
1619,1619 L	05.1975 → 12.1984	OM 401.905 D	325	1638	11.1980 → 12.1986	OM 422.955 D	381
1620,1620 L	07.1985 → 03.1991	OM 366.983 D	190	1638	11.1980 → 12.1986	OM 422.959 D	381
1622 AK	05.1982 → 10.1989	OM 421.905 D	382	1638 S,1638 LS	11.1980 → 12.1986	OM 422.953 D	381
1622 K	05.1982 → 10.1989	OM 421.905 D	382	1638 S,1638 LS	11.1980 → 12.1986	OM 422.955 D	381
1622 S	05.1982 → 03.1991	OM 421.905 D	382	1638 S,1638 LS	11.1980 → 12.1986	OM 422.959 D	381
1622,1622 L	05.1982 → 03.1991	OM 421.905 D	382	1644	06.1986 → 08.1989	OM 442.951 D	390
1624 K	07.1975 → 08.1982	OM 402.910 D	327	1644	06.1986 → 08.1989	OM 442.953 D	390
1624 S,1624 LS	07.1975 → 12.1982	OM 402.911 D	327	1644	06.1986 → 08.1989	OM 442.980 D	391
1624,1624 L	08.1973 → 09.1996	OM 496.900-002 D	323	1644 S,1644 LS	06.1986 → 08.1989	OM 442.951 D	390
		(AFS)		1644 S,1644 LS	06.1986 → 08.1989	OM 442.953 D	390
1624,1624 L	08.1973 → 09.1996	OM 496.900-023 D	323	1644 S,1644 LS	06.1986 → 08.1989	OM 442.980 D	391
		(AFS)		1719	09.1973 → 08.1982	OM 401.909 D	325
1624,1624 L	08.1973 → 09.1996	OM 496.900-034 D	323	1719	09.1973 → 08.1982	OM 401.916 D	325
		(AFS)		1719 AK	09.1973 → 08.1982	OM 401.909 D	325
1624,1624 L	08.1973 → 09.1996	OM 496.900-035 D	323	1719 K	09.1973 → 08.1982	OM 401.909 D	325
		(AFS)		1719 S	09.1973 → 08.1982	OM 401.909 D	325
1624,1624 L	07.1975 → 12.1982	OM 402.911 D	327	1719 S	09.1973 → 08.1982	OM 401.916 D	325
1624,1624 L	02.1977 → 12.1982	OM 402.923 D	327	1814	04.1984 → 03.1991	OM 366.906 D	208
1625 AK	10.1980 → 11.1989	OM 422.909 D	370	1919	05.1974 → 08.1982	OM 401.909 D	325
1625 K	05.1980 → 11.1989	OM 422.909 D	370	1919	05.1974 → 08.1982	OM 401.916 D	325
1625 S,1625 LS	05.1980 → 10.1989	OM 422.909 D	370	1919 AK	05.1974 → 08.1982	OM 401.909 D	325
1625,1625 L	05.1980 → 10.1989	OM 422.909 D	370	1919 K	05.1974 → 08.1982	OM 401.909 D	325
1626 AK	08.1973 → 12.1980	OM 402.906 D	331	1919 S	05.1974 → 08.1982	OM 401.909 D	325
1626 AS	05.1974 → 12.1980	OM 402.906 D	331	1919 S	05.1974 → 08.1982	OM 401.916 D	325
1626 AS	05.1974 → 12.1980	OM 402.912 D	327	1922	10.1981 → 10.1990	OM 421.905 D	382
1626 K	08.1973 → 12.1980	OM 402.906 D	331	1922 AK	10.1981 → 03.1991	OM 421.905 D	382
1626 S,1626 LS	05.1974 → 12.1980	OM 402.906 D	331	1922 K	10.1981 → 03.1991	OM 421.905 D	382
1626 S,1626 LS	05.1974 → 12.1980	OM 402.912 D	327	1922 S	10.1981 → 03.1991	OM 421.905 D	382
1626 S,1626 LS	06.1975 → 12.1980	OM 402.916 D	327	1926	05.1974 → 12.1980	OM 402.906 D	331
1626,1626 L	05.1974 → 12.1980	OM 402.912 D	327	1926	05.1974 → 12.1980	OM 402.912 D	327
1628 A	01.1980 → 05.1989	OM 422.905 D	370	1926 A	05.1974 → 12.1980	OM 402.906 D	331
1628 A	01.1980 → 05.1989	OM 422.906 D	370	1926 A	05.1974 → 12.1980	OM 402.912 D	327
1628 A	01.1980 → 05.1989	OM 422.911 D	370	1926 AK	08.1973 → 12.1980	OM 402.906 D	331
1628 S,1628 LS	01.1980 → 05.1989	OM 422.905 D	370	1926 AK	08.1973 → 12.1980	OM 402.912 D	327
1628 S,1628 LS	01.1980 → 05.1989	OM 422.906 D	370	1926 AS	05.1974 → 12.1980	OM 402.906 D	331
1628 S,1628 LS	01.1980 → 05.1989	OM 422.911 D	370	1926 AS	05.1974 → 12.1980	OM 402.912 D	327
1628,1628 L	01.1980 → 05.1989	OM 422.905 D	370	1926 K	08.1973 → 12.1980	OM 402.906 D	331
1628,1628 L	01.1980 → 05.1989	OM 422.906 D	370	1926 K	08.1973 → 12.1980	OM 402.912 D	327
1628,1628 L	01.1980 → 05.1989	OM 422.911 D	370	1926 S,1926 LS	05.1974 → 12.1980	OM 402.906 D	331
1628,1628 L	02.1980 → 03.1991	OM 422.913 D	370	1926 S,1926 LS	05.1974 → 12.1980	OM 402.912 D	327
1632 AK	05.1974 → 08.1982	OM 403.916 D	330	1926 S,1926 LS	06.1975 → 12.1980	OM 402.916 D	327
1632 AS	05.1974 → 09.1983	OM 403.916 D	330	1928 A	01.1980 → 05.1989	OM 422.911 D	370
1632 AS	05.1974 → 09.1983	OM 403.931 D	330	1928 A	01.1980 → 03.1991	OM 422.905 D	370
1632 K	05.1974 → 08.1982	OM 403.916 D	330	1928 A	01.1980 → 03.1991	OM 422.907 D	370
1632 S,1632 LS	05.1974 → 09.1983	OM 403.916 D	330	1928 A	02.1980 → 03.1991	OM 422.913 D	370
1632 S,1632 LS	05.1974 → 09.1983	OM 403.931 D	330	1928 AK	01.1980 → 05.1989	OM 422.911 D	370
1632 S,1632 LS	05.1974 → 09.1983	OM 403.932 D	330	1928 AK	01.1980 → 03.1991	OM 422.905 D	370
1632,1632 L	05.1974 → 12.1982	OM 403.931 D	330	1928 AK	01.1980 → 03.1991	OM 422.907 D	370
1632,1632 L	05.1974 → 12.1982	OM 403.932 D	330	1928 AK	02.1980 → 03.1991	OM 422.913 D	370
1633 S,1633 LS	10.1980 → 05.1987	OM 422.954 D	381	1928 AS	02.1980 → 03.1991	OM 422.913 D	370
1633 S,1633 LS	11.1980 → 05.1987	OM 422.952 D	381	1928 K	01.1980 → 05.1989	OM 422.911 D	370
1633 S,1633 LS	11.1980 → 05.1987	OM 422.957 D	381	1928 K	01.1980 → 03.1991	OM 422.905 D	370
1633 S,1633 LS	11.1980 → 05.1987	OM 422.958 D	381	1928 K	01.1980 → 03.1991	OM 422.907 D	370
1633 S,1633 LS	11.1983 → 05.1987	OM 422.956 D	381	1928 K	02.1980 → 03.1991	OM 422.913 D	370
1633,1633 L	10.1980 → 05.1987	OM 422.954 D	381	1928 S,1928 LS	01.1980 → 05.1989	OM 422.911 D	370
1633,1633 L	11.1980 → 05.1987	OM 422.952 D	381	1928 S,1928 LS	01.1980 → 03.1991	OM 422.906 D	370
1633,1633 L	11.1980 → 05.1987	OM 422.957 D	381	1928,1928 L	08.1973 → 09.1996	OM 492.900-002 D	375
1633,1633 L	11.1980 → 05.1987	OM 422.958 D	381		(AFS)		
1633,1633 L	11.1983 → 05.1987	OM 422.956 D	381	1928,1928 L	08.1973 → 09.1996	OM 496.900-401 D	332
1635 K	02.1986 → 07.1989	OM 442.950 D	390		(AFS)		
1635 K	02.1986 → 07.1989	OM 442.952 D	390	1928,1928 L	08.1973 → 09.1996	OM 496.900-426 D	332
1635 S,1635 LS	02.1986 → 07.1989	OM 442.950 D	390		(AFS)		
1635 S,1635 LS	02.1986 → 07.1989	OM 442.952 D	390	1928,1928 L	08.1973 → 09.1996	OM 496.900-430 D	332
1635,1635 L	02.1986 → 07.1989	OM 442.950 D	390		(AFS)		

M



# MERCEDES-BENZ

			Pos				Pos
1928,1928 L	01.1980 → 05.1989	OM 422.905	D 370	2033 LS	11.1983 → 05.1987	OM 422.956	D 381
1928,1928 L	01.1980 → 05.1989	OM 422.906	D 370	2035 S,2035 LS	06.1986 → 07.1989	OM 442.950	D 390
1928,1928 L	01.1980 → 05.1989	OM 422.907	D 370	2035 S,2035 LS	06.1986 → 07.1989	OM 442.952	D 390
1928,1928 L	01.1980 → 05.1989	OM 422.911	D 370	2035 S,2035 LS	06.1986 → 07.1989	OM 442.958	D 390
1928,1928 L	02.1980 → 05.1989	OM 422.913	D 370	2036 A	02.1986 → 06.1989	OM 442.950	D 390
1932	05.1974 → 03.1983	OM 345.950 (BRA)	D 368	2036 A	09.1987 → 06.1989	OM 442.962	D 391
1932	05.1974 → 03.1983	OM 403.916	D 330	2036 LS	03.1984 → 03.1991	OM 423.905	D 382
1932	05.1974 → 03.1983	OM 403.931	D 330	2036 LS	03.1984 → 03.1991	OM 423.908	D 382
1932 A	05.1974 → 03.1983	OM 403.916	D 330	2219	06.1976 → 01.1987	OM 401.926	D 325
1932 A	05.1974 → 03.1983	OM 403.931	D 330	2219 C,2219 CL	02.1983 → 09.1985	OM 362.906	D 170
1932 AK	08.1973 → 09.1983	OM 403.931	D 330	2219 C,2219 CL	02.1983 → 09.1985	OM 362.906	D 170
1932 AK	05.1974 → 09.1983	OM 403.916	D 330	2219 C,2219 CL	05.1983 → 06.1985	OM 362.909	D 170
1932 AS	05.1974 → 12.1982	OM 403.916	D 330	2219 C,2219 CL	05.1983 → 06.1985	OM 362.909	D 170
1932 AS	05.1974 → 12.1982	OM 403.931	D 330	2219 K	06.1976 → 01.1987	OM 401.925	D 325
1932 K	08.1973 → 08.1982	OM 403.931	D 330	2219,2219 L	08.1973 → 09.1996	OM 495.900-001	D 323
1932 K	05.1974 → 08.1982	OM 403.916	D 330			(AFS)	
1932 S,1932 LS	05.1974 → 12.1982	OM 403.916	D 330	2219,2219 L	08.1973 → 09.1996	OM 495.900-003	D 323
1932 S,1932 LS	05.1974 → 12.1982	OM 403.931	D 330			(AFS)	
1933	11.1980 → 03.1991	OM 345.950 (BRA)	D 368	2219,2219 L	08.1973 → 09.1996	OM 495.900-009	D 323
1933	11.1980 → 03.1991	OM 422.952	D 381			(AFS)	
1933	11.1980 → 03.1991	OM 422.954	D 381	2219,2219 L	08.1973 → 09.1996	OM 495.900-010	D 323
1933	11.1980 → 03.1991	OM 422.957	D 381			(AFS)	
1933	11.1980 → 03.1991	OM 422.958	D 381	2219,2219 L	04.1976 → 01.1987	OM 401.926	D 325
1933	11.1983 → 05.1987	OM 422.956	D 381	2219,2219 L	04.1976 → 01.1987	OM 401.927	D 325
1933	10.1984 → 03.1991	OM 492.900-409	D 383	2219,2219 L	09.1976 → 01.1987	OM 401.923	D 325
		(AFS)		2220,2220 L	08.1973 → 09.1996	OM 345.970 (BRA)	D 368
1933 S,1933 LS	11.1980 → 03.1991	OM 422.952	D 381	2220,2220 L	07.1985 → 03.1991	OM 366.983	D 190
1933 S,1933 LS	11.1980 → 03.1991	OM 422.954	D 381	2220,2220 L	07.1985 → 03.1991	OM 366.983	D 190
1933 S,1933 LS	11.1980 → 03.1991	OM 422.957	D 381	2222	05.1982 → 03.1991	OM 421.905	D 382
1933 S,1933 LS	11.1980 → 03.1991	OM 422.958	D 381	2222 K	05.1982 → 10.1989	OM 421.905	D 382
1933 S,1933 LS	11.1983 → 05.1987	OM 422.956	D 381	2222 K	05.1982 → 03.1991	OM 421.905	D 382
1935	02.1986 → 09.1989	OM 442.950	D 390	2222 L	08.1973 → 09.1996	OM 441.905	D 503
1935	02.1986 → 09.1989	OM 442.952	D 390	2222 L	08.1973 → 09.1996	OM 441.917	D 503
1935 AK	09.1987 → 03.1991	OM 442.962	D 391	2222 L	08.1973 → 09.1996	OM 441.919	D 503
1935 AS	09.1987 → 03.1991	OM 442.962	D 391	2222 L	10.1981 → 02.1993	OM 421.905	D 382
1935 S,1935 LS	02.1986 → 09.1989	OM 442.950	D 390	2222 L	08.1989 → 08.1994	OM 441.914	D 503
1935 S,1935 LS	02.1986 → 09.1989	OM 442.952	D 390	2222,2222 L	05.1982 → 03.1991	OM 421.905	D 382
1936	10.1981 → 03.1991	OM 423.905	D 382	2222,2222 L	05.1982 → 03.1991	OM 421.905	D 382
1936	10.1981 → 03.1991	OM 423.906	D 382	2224	04.1976 → 12.1982	OM 402.911	D 327
1936	10.1981 → 03.1991	OM 423.908	D 382	2224	04.1976 → 12.1982	OM 402.911	D 327
1936 AK	10.1981 → 03.1991	OM 423.905	D 382	2224	04.1976 → 12.1982	OM 402.928	D 327
1936 AK	10.1981 → 03.1991	OM 423.906	D 382	2224	04.1976 → 12.1982	OM 402.928	D 327
1936 AK	10.1981 → 03.1991	OM 423.907	D 382	2224 K	04.1976 → 12.1982	OM 402.910	D 327
1936 AS	10.1981 → 03.1991	OM 423.905	D 382	2224 K	04.1976 → 12.1982	OM 402.927	D 327
1936 AS	10.1981 → 03.1991	OM 423.906	D 382	2224 S	07.1976 → 12.1982	OM 402.911	D 327
1936 AS	10.1981 → 03.1991	OM 423.907	D 382	2224 S	07.1976 → 12.1982	OM 402.928	D 327
1936 K	10.1981 → 03.1991	OM 423.905	D 382	2225	04.1985 → 03.1991	OM 345.970 (BRA)	D 368
1936 S,1936 LS	10.1981 → 03.1991	OM 423.908	D 382	2225	04.1985 → 03.1991	OM 422.909	D 370
1938	11.1980 → 12.1986	OM 422.959	D 381	2225	04.1985 → 03.1991	OM 492.900-001	D 375
1938	11.1980 → 06.1990	OM 422.953	D 381			(AFS)	
1938 S,1938 LS	11.1980 → 12.1986	OM 422.959	D 381	2225 L	05.1980 → 03.1993	OM 422.909	D 370
1938 S,1938 LS	11.1980 → 06.1990	OM 422.953	D 381	2226	09.1975 → 12.1980	OM 402.912	D 327
1938 S,1938 LS	11.1980 → 06.1990	OM 422.955	D 381	2226	09.1975 → 12.1980	OM 402.916	D 327
1944	10.1985 → 12.1989	OM 442.951	D 390	2226	09.1975 → 12.1980	OM 402.924	D 327
1944 S,1944 LS	10.1985 → 12.1989	OM 442.951	D 390	2226 S,2226 LS	06.1975 → 12.1980	OM 402.912	D 327
2025 S	08.1983 → 03.1991	OM 422.909	D 370	2226 S,2226 LS	06.1975 → 12.1980	OM 402.916	D 327
2026 S	10.1976 → 10.1980	OM 402.912	D 327	2226 S,2226 LS	06.1975 → 12.1980	OM 402.924	D 327
2026 S	10.1976 → 10.1980	OM 402.916	D 327	2226,2226 L	09.1975 → 12.1980	OM 402.912	D 327
2028 A	01.1980 → 05.1989	OM 422.911	D 370	2226,2226 L	09.1975 → 12.1980	OM 402.916	D 327
2028 A	01.1980 → 06.1989	OM 422.907	D 370	2226,2226 L	09.1975 → 12.1980	OM 402.924	D 327
2028 A	01.1980 → 06.1989	OM 422.916	D 370	2228	12.1979 → 03.1991	OM 422.905	D 370
2028 A	02.1980 → 06.1989	OM 422.913	D 370	2228	01.1980 → 05.1989	OM 422.911	D 370
2028 LS	01.1980 → 05.1989	OM 422.911	D 370	2228 S	12.1979 → 03.1991	OM 422.905	D 370
2028 LS	01.1980 → 06.1989	OM 422.905	D 370	2228 S	01.1980 → 05.1989	OM 422.911	D 370
2028 LS	01.1980 → 06.1989	OM 422.906	D 370	2228,2228 L	12.1979 → 03.1991	OM 422.905	D 370
2028 LS	01.1980 → 06.1989	OM 422.910	D 370	2228,2228 L	12.1979 → 03.1991	OM 422.906	D 370
2032 S	08.1975 → 09.1983	OM 403.931	D 330	2228,2228 L	01.1980 → 05.1989	OM 422.911	D 370
2032 S	08.1975 → 09.1983	OM 403.932	D 330	2232	05.1974 → 09.1983	OM 403.931	D 330
2033 LS	12.1981 → 05.1987	OM 422.952	D 381	2232	05.1974 → 09.1983	OM 403.932	D 330
				2232 S,2232 LS	05.1974 → 09.1983	OM 403.931	D 330

			Pos				Pos
2232 S,2232 LS	05.1974 → 09.1983	OM 403.932	D 330	2536 AK	02.1986 → 03.1991	OM 442.952	D 390
2232,2232 L	05.1975 → 09.1983	OM 403.931	D 330	2536 AK	09.1987 → 03.1991	OM 442.962	D 391
2232,2232 L	05.1975 → 09.1983	OM 403.932	D 330	2626	06.1975 → 12.1980	OM 402.906	D 331
2233	11.1980 → 05.1987	OM 422.952	D 381	2626	06.1975 → 03.1981	OM 402.916	D 327
2233	11.1980 → 05.1987	OM 422.954	D 381	2626 A	06.1975 → 12.1980	OM 402.906	D 331
2233	11.1980 → 05.1987	OM 422.957	D 381	2626 A	06.1975 → 03.1981	OM 402.916	D 327
2233 S	11.1980 → 05.1987	OM 422.957	D 381	2626 AK	08.1973 → 12.1980	OM 402.906	D 331
2233 S	11.1980 → 05.1987	OM 422.958	D 381	2626 AK	08.1973 → 12.1980	OM 402.912	D 327
2233,2233 L	11.1980 → 05.1987	OM 422.952	D 381	2626 AS	06.1975 → 12.1980	OM 402.906	D 331
2233,2233 L	11.1980 → 05.1987	OM 422.954	D 381	2626 AS	06.1975 → 03.1981	OM 402.916	D 327
2233,2233 L	11.1980 → 05.1987	OM 422.957	D 381	2626 K	08.1973 → 12.1980	OM 402.906	D 331
2233,2233 L	11.1980 → 05.1987	OM 422.958	D 381	2626 K	08.1973 → 12.1980	OM 402.912	D 327
2233,2233 L	10.1984 → 09.1996	OM 492.900-405 (AFS)	D 383	2626 S	06.1975 → 12.1980	OM 402.906	D 331
2235 K	03.1986 → 07.1989	OM 442.950	D 390	2626 S	06.1975 → 03.1981	OM 402.916	D 327
2235 S, 2235 LS	03.1986 → 07.1989	OM 442.950	D 390	2628	02.1980 → 05.1989	OM 422.911	D 370
2235,2235 L	03.1986 → 07.1989	OM 442.950	D 390	2628	02.1980 → 03.1991	OM 422.905	D 370
2236	09.1982 → 03.1991	OM 423.905	D 382	2628	02.1980 → 03.1991	OM 492.900-002 (AFS)	D 375
2236	09.1982 → 03.1991	OM 423.908	D 382	2628	02.1980 → 03.1991	OM 496.900-401 (AFS)	D 332
2236 S	12.1984 → 03.1991	OM 423.905	D 382	2628	02.1980 → 03.1991	OM 496.900-402 (AFS)	D 332
2236 S	12.1984 → 03.1991	OM 423.908	D 382	2628	02.1980 → 03.1991	OM 496.900-426 (AFS)	D 332
2238 S	01.1981 → 12.1986	OM 422.953	D 381	2628 A	02.1980 → 03.1991	OM 422.907	D 370
2238 S	01.1981 → 12.1986	OM 422.955	D 381	2628 A	02.1980 → 03.1991	OM 422.913	D 370
2238 S	01.1981 → 12.1986	OM 422.959	D 381	2628 A	02.1980 → 03.1991	OM 422.916	D 370
2238,2238 L	01.1981 → 12.1986	OM 422.953	D 381	2628 A	01.1990 → 03.1991	OM 443.940	D 404
2238,2238 L	01.1981 → 12.1986	OM 422.955	D 381	2628 AK	02.1980 → 03.1991	OM 422.913	D 370
2238,2238 L	01.1981 → 12.1986	OM 422.959	D 381	2628 AS	02.1980 → 03.1991	OM 422.907	D 370
2244 S	10.1985 → 07.1989	OM 442.951	D 390	2628 AS	02.1980 → 03.1991	OM 422.913	D 370
2244,2244 L	10.1985 → 07.1989	OM 442.951	D 390	2628 AS	02.1980 → 03.1991	OM 422.913	D 370
2244,2244 L	10.1985 → 03.1992	OM 442.980	D 391	2628 K	02.1980 → 05.1989	OM 422.911	D 370
2244,2244 L	06.1986 → 03.1992	OM 442.953	D 390	2628 K	02.1980 → 03.1991	OM 422.905	D 370
2422	08.1973 → 09.1996	OM 441.919	D 503	2628 S	02.1980 → 05.1989	OM 422.911	D 370
2422	10.1981 → 10.1990	OM 421.905	D 382	2628 S	02.1980 → 03.1991	OM 422.905	D 370
2422	08.1989 → 08.1994	OM 441.914	D 503	2632	05.1974 → 09.1983	OM 403.916	D 330
2422 K	10.1981 → 03.1991	OM 421.905	D 382	2632	05.1974 → 09.1983	OM 403.932	D 330
2425	04.1985 → 03.1991	OM 422.909	D 370	2632	05.1974 → 09.1983	OM 496.900-501 (AFS)	D 332
2428	01.1980 → 05.1989	OM 422.905	D 370	2632 A	05.1974 → 09.1983	OM 403.916	D 330
2428	01.1980 → 05.1989	OM 422.911	D 370	2632 A	05.1974 → 09.1983	OM 403.932	D 330
2428	01.1980 → 06.1989	OM 422.916	D 370	2632 AK	08.1973 → 09.1983	OM 403.931	D 330
2428	02.1980 → 05.1989	OM 422.913	D 370	2632 AK	08.1973 → 09.1983	OM 403.935	D 330
2433	10.1980 → 03.1991	OM 422.954	D 381	2632 AK	05.1974 → 09.1983	OM 403.916	D 330
2433	11.1980 → 03.1991	OM 422.954	D 381	2632 AS	05.1974 → 09.1983	OM 403.916	D 330
2433	11.1980 → 03.1991	OM 422.957	D 381	2632 AS	05.1974 → 09.1983	OM 403.931	D 330
2433	11.1980 → 03.1991	OM 422.957	D 381	2632 AS	05.1974 → 09.1983	OM 403.932	D 330
2438	11.1980 → 12.1986	OM 422.959	D 381	2632 K	08.1973 → 09.1983	OM 403.931	D 330
2438	11.1980 → 06.1990	OM 422.953	D 381	2632 K	08.1973 → 09.1983	OM 403.935	D 330
2438	11.1980 → 06.1990	OM 422.955	D 381	2632 K	08.1973 → 09.1983	OM 403.916	D 330
2438 L	11.1980 → 12.1986	OM 422.959	D 381	2632 K	05.1974 → 09.1983	OM 403.916	D 330
2438 L	11.1980 → 06.1990	OM 422.955	D 381	2632 S	05.1974 → 09.1983	OM 403.916	D 330
2444 LS	08.1973 → 09.1996	OM 462.900-510 (AFS)	D 374	2632 S	05.1974 → 09.1983	OM 403.931	D 330
2444 LS	10.1985 → 12.1989	OM 442.951	D 390	2632 S	05.1974 → 09.1983	OM 403.932	D 330
2444 LS	10.1985 → 12.1989	OM 442.951	D 390	2633	05.1982 → 05.1987	OM 422.952	D 381
2444 LS	10.1985 → 03.1992	OM 442.980	D 391	2633	05.1982 → 05.1987	OM 422.954	D 381
2444 LS	10.1985 → 03.1992	OM 442.980	D 391	2633	05.1982 → 05.1987	OM 422.957	D 381
2444 LS	06.1986 → 03.1992	OM 442.953	D 390	2633	10.1984 → 05.1987	OM 492.900-406 (AFS)	D 383
2444 LS	06.1986 → 03.1992	OM 442.953	D 390	2633 S	05.1982 → 05.1987	OM 422.952	D 381
2444 LS	07.1987 → 09.1996	OM 462.900-511 (AFS)	D 407	2633 S	05.1982 → 05.1987	OM 422.954	D 381
2528 A	01.1980 → 05.1989	OM 422.911	D 370	2633 S	11.1983 → 05.1987	OM 422.956	D 381
2528 A	01.1980 → 06.1989	OM 422.916	D 370	2635	04.1986 → 03.1991	OM 442.950	D 390
2528 A	01.1980 → 03.1991	OM 422.907	D 370	2635	04.1986 → 03.1991	OM 442.952	D 390
2528 AK	01.1980 → 05.1989	OM 422.911	D 370	2635 A	09.1987 → 03.1991	OM 442.962	D 391
2528 AK	01.1980 → 03.1991	OM 422.907	D 370	2635 AK	09.1987 → 03.1991	OM 442.962	D 391
2528 AK	01.1980 → 03.1991	OM 422.916	D 370	2635 AS	09.1987 → 03.1991	OM 442.962	D 391
2528 AK	02.1980 → 03.1991	OM 422.913	D 370	2635 S	04.1986 → 03.1991	OM 442.950	D 390
2536 AK	10.1981 → 03.1991	OM 423.905	D 382	2635 S	04.1986 → 03.1991	OM 442.952	D 390
2536 AK	10.1981 → 03.1991	OM 423.907	D 382	2636	11.1981 → 03.1991	OM 423.905	D 382
2536 AK	02.1986 → 03.1991	OM 442.950	D 390				

M

			Pos				Pos
2636	11.1981 → 03.1991	OM 493.900-001 (AFS)	D 383	3544 S	10.1985 → 12.1989	OM 442.951	D 390
2636 A	11.1981 → 03.1991	OM 423.907	D 382	3544 S	10.1985 → 03.1992	OM 442.980	D 391
2636 AK	11.1981 → 03.1991	OM 423.907	D 382	3836 AK	11.1981 → 03.1991	OM 423.907	D 382
2636 AS	11.1981 → 03.1991	OM 423.907	D 382	3850 A	09.1985 → 08.1994	OM 423.950	D 387
2636 K	11.1981 → 03.1991	OM 423.905	D 382	<b>O 100</b>			
2636 S	11.1981 → 03.1991	OM 423.905	D 382	140		OM 341.915	D 137
2638	01.1981 → 12.1986	OM 422.953	D 381	140		OM 341.995	D 137
2638	01.1981 → 12.1986	OM 422.955	D 381	170	06.1973 →	OM 341.943	D 143
2638	01.1981 → 12.1986	OM 422.959	D 381	170	06.1973 →	OM 341.996	D 142
2638 S	01.1981 → 12.1986	OM 422.953	D 381	City	01.1994 →	OM 602.940	D 82
2638 S	01.1981 → 12.1986	OM 422.955	D 381	<b>O 301</b>			
2638 S	10.1984 → 12.1986	OM 492.900-501 (AFS)	D 383	O 301	02.1986 → 05.1987	OM 366.965	D 195
				O 301	06.1986 → 05.1987	OM 366.917	D 208
				<b>O 302</b>			
2644	10.1985 → 12.1989	OM 442.951	D 390	O 302	11.1964 → 11.1969	OM 352.980	D 130
2644	10.1985 → 03.1992	OM 442.980	D 391	O 302	11.1964 → 12.1974	OM 352.993	D 130
2644	06.1986 → 03.1992	OM 442.953	D 390	O 302	11.1964 → 12.1975	OM 481.904	D 362
2644 S	10.1985 → 02.1990	OM 442.980	D 391	O 302	05.1969 → 12.1974	OM 360.916	D 321
2644 S	06.1986 → 02.1990	OM 442.953	D 390	O 302	05.1969 → 12.1974	OM 360.979	D 321
2644 S	07.1987 → 02.1990	OM 462.900-511 (AFS)	D 407	O 302	05.1969 → 12.1974	OM 360.980	D 321
				O 302	05.1969 → 12.1974	OM 360.981	D 321
3025 K	04.1985 → 03.1991	OM 422.909	D 370	O 302	05.1969 → 12.1974	OM 360.984	D 321
3025 K	12.1985 → 07.1987	OM 422.920	D 370	O 302	05.1969 → 12.1974	OM 360.985	D 321
3028	02.1980 → 05.1989	OM 422.911	D 370	O 302	05.1969 → 12.1974	OM 360.986	D 321
3028	02.1980 → 03.1991	OM 422.905	D 370	O 302	04.1973 → 12.1975	OM 421.908	D 373
3028 K	12.1985 → 07.1987	OM 422.919	D 370	<b>O 303</b>			
3033	05.1982 → 05.1987	OM 422.954	D 381	O 303	10.1974 → 06.1983	OM 401.907	D 325
3033	05.1982 → 05.1987	OM 422.957	D 381	O 303	10.1974 → 06.1983	OM 401.908	D 325
3036	11.1981 → 03.1991	OM 423.905	D 382	O 303	10.1974 → 06.1983	OM 401.912	D 330
3036	11.1981 → 03.1991	OM 423.908	D 382	O 303	10.1974 → 06.1983	OM 401.912	D 330
3038	01.1981 → 12.1986	OM 422.953	D 381	O 303	10.1974 → 06.1983	OM 401.912	D 330
3038	01.1981 → 12.1986	OM 422.955	D 381	O 303	03.1975 → 06.1983	OM 402.907	D 327
3038	01.1981 → 12.1986	OM 422.959	D 381	O 303	07.1975 → 06.1983	OM 403.918	D 330
3228 K	07.1987 → 07.1987	OM 422.919	D 370	O 303	01.1980 → 07.1977	OM 421.908	D 373
3228 K	07.1987 → 03.1991	OM 422.921	D 370	O 303	01.1980 → 07.1977	OM 421.908	D 373
3235	07.1988 → 08.1994	OM 442.944	D 390	O 303	01.1980 → 07.1977	OM 421.908	D 373
3250 A	09.1985 → 08.1994	OM 423.950	D 387	O 303	01.1980 → 07.1977	OM 421.908	D 373
3328	02.1980 → 05.1989	OM 422.911	D 370	O 303	01.1980 → 09.1987	OM 422.908	D 370
3328	02.1980 → 03.1991	OM 422.905	D 370	O 303	01.1980 → 09.1987	OM 422.908	D 370
3328	02.1980 → 03.1991	OM 422.913	D 370	O 303	01.1980 → 09.1987	OM 422.917	D 370
3328 K	07.1982 → 07.1987	OM 422.914	D 370	O 303	01.1980 → 09.1987	OM 422.917	D 370
3328 K	07.1982 → 07.1987	OM 422.919	D 370	O 303	08.1980 → 09.1987	OM 422.951	D 381
3333	12.1982 → 03.1991	OM 422.954	D 381	O 303	08.1980 → 09.1987	OM 422.963	D 381
3333 K	12.1982 → 03.1991	OM 422.954	D 381	O 303	11.1985 → 04.1989	OM 421.951	D 397
3335	04.1986 → 03.1991	OM 442.952	D 390	O 303	11.1985 → 04.1989	OM 441.950	D 398
3335	05.1986 → 03.1991	OM 442.950	D 390	O 303	09.1987 → 09.1992	OM 442.910	D 504
3335 A	09.1987 → 03.1991	OM 442.962	D 391	O 303	09.1987 → 09.1992	OM 442.911	D 504
3336	12.1982 → 03.1991	OM 423.905	D 382	O 303	09.1987 → 09.1992	OM 442.918	D 504
3336	12.1982 → 03.1991	OM 423.907	D 382	O 303	09.1987 → 09.1992	OM 442.939	D 504
3336 A	11.1981 → 03.1991	OM 423.905	D 382	O 303	09.1987 → 09.1992	OM 442.954	D 390
3336 A	11.1981 → 03.1991	OM 423.907	D 382	O 303	09.1987 → 09.1992	OM 442.955	D 390
3336 A	02.1986 → 03.1991	OM 442.950	D 390	O 303	09.1987 → 09.1992	OM 442.960	D 391
3336 A	02.1986 → 03.1991	OM 442.952	D 390	O 303	09.1987 → 09.1992	OM 442.961	D 391
3336 AK	09.1986 → 03.1991	OM 423.907	D 382	O 303	12.1987 → 09.1992	OM 441.908	D 503
3336 K	12.1982 → 03.1991	OM 423.905	D 382	O 303	12.1987 → 09.1992	OM 441.909	D 503
3336 S	12.1982 → 03.1991	OM 423.905	D 382	O 303	12.1987 → 09.1992	OM 441.911	D 503
3338	1985 → 12.1986	OM 442.950	D 390	O 303	12.1987 → 09.1992	OM 441.918	D 503
3528	07.1982 → 07.1987	OM 422.905	D 370	O 303	12.1987 → 09.1992	OM 441.950	D 398
3528	07.1982 → 07.1987	OM 422.919	D 370	O 303	12.1987 → 09.1992	OM 441.953	D 398
3528 K	07.1982 → 07.1987	OM 422.919	D 370	<b>O 304</b>			
3528 K	07.1987 → 07.1987	OM 422.919	D 370	O304	08.1992 →	OM 402.984	D 338
3535 AK	09.1987 → 02.1990	OM 442.950	D 390	O304	07.1995 →	OM 441.994	D 428
3535 AK	09.1987 → 02.1990	OM 442.952	D 390	<b>O 305</b>			
3535 K	09.1987 → 01.1989	OM 442.950	D 390	O 305 G	02.1978 → 05.1987	OM 407.919	D 330
3535 K	09.1987 → 01.1989	OM 442.959	D 390	O 305 G	02.1979 → 05.1987	OM 407.951	D 334
3536 K	12.1982 → 03.1991	OM 423.907	D 382	O 305 G	02.1979 → 05.1987	OM 407.955	D 334
3544	10.1985 → 12.1989	OM 442.951	D 390	O 305 ST	04.1973 → 07.1977	OM 407.905	D 330
3544	10.1985 → 03.1992	OM 442.980	D 391	O 305 ST	04.1973 → 07.1977	OM 407.908	D 330
3544	06.1986 → 03.1992	OM 442.953	D 390	O 305 ST	04.1973 → 07.1977	OM 407.909	D 330



				Pos					Pos	
O 305 ST	04.1973 → 07.1977	OM 407.910	D	330	322	01.1968 → 12.1982	OM 352.908	D	130	
O 305 ST	04.1973 → 07.1977	OM 407.911	D	330	322	01.1968 → 12.1982	OM 352.953	D	129	
O 305 ST	11.1976 → 05.1987	OM 407.913	D	330	322	01.1968 → 12.1982	OM 352.955	D	129	
O 305 ST	11.1976 → 05.1987	OM 407.914	D	330	322	01.1968 → 12.1982	OM 352.987	D	129	
O 305 ST	11.1976 → 05.1987	OM 407.917	D	330	322	01.1968 → 12.1982	OM 352.991	D	129	
O 305 ST	02.1979 → 05.1987	OM 407.951	D	334	322	1971 → 1982	OM 352.918	D	133	
O 305 ST	02.1979 → 05.1987	OM 407.955	D	334	<b>O 326</b>					
<b>O 307</b>					326		OM 345.933	D	376	
O 307	04.1973 → 07.1977	OM 407.905	D	330	<b>O 330</b>					
O 307	04.1973 → 07.1977	OM 407.907	D	330	O 330	01.1990 → 09.1992	OM 442.939	D	504	
O 307	04.1973 → 07.1977	OM 407.911	D	330	O 330	01.1990 →	OM 442.955	D	390	
O 307	11.1976 → 07.1977	OM 407.916	D	330	O 330	01.1990 →	OM 442.961	D	391	
O 307	11.1976 → 07.1977	OM 407.918	D	330	<b>O 340</b>					
O 307	11.1976 → 07.1987	OM 407.915	D	330	O 340	08.1992 → 08.1995	OM 402.984	D	338	
O 307	02.1979 → 05.1987	OM 407.955	D	334	O 340	07.1995 → 06.1995	OM 441.994	D	428	
<b>O 309</b>					O 340	07.1995 → 06.1995	OM 441.995	D	428	
D 2.4	01.1975 → 08.1982	OM 616.910	D	106	Tourismo	08.1992 → 08.1995	OM 402.984	D	338	
D 2.4	12.1980 → 06.1989	OM 616.960	D	102	Tourismo	08.1992 → 08.1995	OM 402.995	D	338	
D 2.4	09.1982 → 02.1989	OM 616.937	D	102	<b>O 355</b>					
D 2.4	09.1982 → 02.1989	OM 616.939	D	102	355	05.1974 → 05.1979	OM 345.932	D	376	
D 5.7	05.1977 → 02.1989	OM 352.904	D	129	<b>O 362</b>					
D 5.7	05.1977 → 02.1989	OM 352.908	D	130	362	01.1975 → 10.1994	OM 344.933	D	137	
D 5.7	05.1977 → 02.1989	OM 352.953	D	129	362	01.1975 → 10.1994	OM 344.934	D	144	
D 5.7	05.1977 → 02.1989	OM 352.955	D	129	<b>O 364</b>					
D 5.7	05.1977 → 02.1989	OM 352.987	D	129	364	06.1976 →	OM 344.945	D	159	
D 5.7	05.1977 → 02.1989	OM 352.991	D	129	364	06.1976 →	OM 345.946	D	363	
D 5.7	05.1977 → 02.1989	OM 353.963	D	130	364	06.1976 →	OM 352.916	D	133	
D 5.7	05.1977 → 02.1989	OM 353.966	D	130	364	07.1979 →	OM 345.936	D	376	
D 5.7	05.1977 → 02.1989	OM 353.968	D	130	364	01.1980 →	OM 344.944	D	137	
D 5.7	05.1977 → 02.1989	OM 353.969	D	130	364	01.1980 →	OM 345.945	D	363	
O 309 B	01.1968 → 02.1968	M 121.943	B	58	<b>O 364 13R</b>		01.1985 →	OM 345.936	D	376
O 309 B	01.1968 → 02.1989	M 102.943	B	118	<b>O 365</b>					
O 309 B	08.1972 → 12.1974	M 115.921	B	58	365	10.1987 →	OM 344.944	D	137	
O 309 B	01.1975 → 08.1982	M 115.952	B	117	365	10.1987 →	OM 344.945	D	159	
O 309 D	01.1968 → 12.1969	OM 621.932	D	59	365	10.1987 →	OM 345.945	D	363	
O 309 D	01.1968 → 12.1974	OM 615.910	D	59	365	10.1987 →	OM 352.916	D	133	
O 309 D	01.1970 → 12.1988	OM 314.946	D	131	<b>O 370</b>					
O 309 D	01.1970 → 02.1989	OM 314.948	D	131	370	03.1986 → 06.1987	OM 345.949	D	368	
O 309 D	01.1970 → 02.1989	OM 314.959	D	131	370	03.1986 → 06.1987	OM 345.972	D	368	
O 309 D	01.1970 → 02.1989	OM 314.962	D	131	370	03.1986 → 06.1987	OM 345.974 (BR)	D	368	
O 309 D	01.1970 → 02.1989	OM 314.963	D	131	370	03.1986 → 06.1987	OM 345.975	D	368	
O 309 D	01.1975 → 12.1988	OM 616.910	D	106	370	03.1986 →	OM 376.905	D	185	
O 309 D	05.1977 → 12.1988	OM 353.963	D	130	370	10.1990 →	OM 345.937	D	376	
O 309 D	05.1977 → 02.1989	OM 353.966	D	130	370	10.1990 →	OM 345.952 (BRA)	D	368	
O 309 D	05.1977 → 02.1989	OM 353.968	D	130	370	10.1990 →	OM 345.960	D	377	
O 309 D	05.1977 → 02.1989	OM 353.969	D	130	<b>O 371</b>					
<b>O 317</b>					371	03.1986 →	OM 345.937	D	376	
O 317	01.1966 → 01.1976	OM 346.911	D	361	371	03.1986 →	OM 345.949	D	368	
O 317	01.1966 → 01.1976	OM 346.918	D	361	371	03.1986 →	OM 345.952 (BRA)	D	368	
O 317	01.1966 → 01.1976	OM 346.946	D	361	371	03.1986 →	OM 345.960	D	377	
<b>O 319</b>					371	03.1986 →	OM 345.972	D	368	
1.9	01.1955 → 1961	M 121.922	B	51	371	03.1986 →	OM 345.974 (BR)	D	368	
1.9	06.1961 → 08.1965	M 121.926	B	51	371	03.1986 →	OM 345.975	D	368	
1.9	06.1961 → 08.1965	M 121.929	B	51	371	03.1986 →	OM 345.977 (BRA)	D	368	
2.0	08.1965 → 02.1968	M 121.941	B	58	371	03.1986 →	OM 345.978 (BRA)	D	368	
2.0	08.1965 → 02.1968	M 121.942	B	58	371	03.1986 →	OM 366.941	D	190	
D	01.1951 → 1961	OM 636.919	D	5	371	03.1986 →	OM 366.942	D	190	
<b>O 321</b>					371	03.1986 →	OM 366.943	D	190	
321	01.1964 → 1970	OM 352.915	D	129	371	03.1986 →	OM 366.999	D	190	
321	01.1964 → 1981	OM 352.914	D	129	371	03.1986 →	OM 376.905	D	185	
321	01.1964 → 12.1982	OM 352.904	D	129	371	03.1986 →	OM 376.906	D	185	
321	01.1964 → 12.1982	OM 352.908	D	130	371	03.1986 →	OM 376.994	D	220	
321	01.1964 → 12.1982	OM 352.953	D	129	371	03.1986 →	OM 377.967	D	187	
321	01.1964 → 12.1982	OM 352.955	D	129	371	03.1986 →	OM 377.969	D	187	
321	01.1964 → 12.1982	OM 352.991	D	129	371	03.1986 →	OM 475.950	D	401	
321	1971 → 1982	OM 352.916	D	133	371	03.1986 →	OM 475.952	D	401	
<b>O 322</b>					371	03.1986 →	OM 476.981	D	401	
322	01.1968 → 1970	OM 352.917	D	129	371	03.1986 →	OM 476.982	D	401	
322	01.1968 → 12.1982	OM 352.904	D	129	371	05.1988 →	OM 376.961	D	186	

M

		Pos			Pos		
O 371	01.1991 → 12.2002	OM 376.961 D	186	O 404	09.1991 → 10.1999	OM 401.970 D	336
O 371	01.1991 → 12.2002	OM 475.952 D	401	O 404	09.1991 → 10.1999	OM 401.970 D	336
O 371	01.1991 → 12.2002	OM 475.984 D	417	O 404	09.1991 → 10.1999	OM 401.970 D	336
O 371	01.1991 → 12.2002	OM 475.998 D	417	O 404	09.1991 → 10.1999	OM 401.974 D	336
O 371	01.1991 → 12.2002	OM 476.977 D	401	O 404	09.1991 → 10.1999	OM 401.974 D	336
O 371	01.1991 → 12.2002	OM 476.977 D	401	O 404	09.1991 → 10.1999	OM 402.970 D	338
O 371	01.1991 → 12.2002	OM 476.981 D	401	O 404	09.1991 → 10.1999	OM 402.970 D	338
O 371	01.1991 → 12.2002	OM 476.981 D	401	O 404	09.1991 → 10.1999	OM 402.974 D	338
O 371	01.1991 → 12.2002	OM 476.985 D	417	O 404	09.1991 → 10.1999	OM 441.980 D	428
O 371	01.1991 → 12.2002	OM 476.985 D	417	O 404	09.1991 → 10.1999	OM 441.980 D	428
O 371 R	03.1986 → 12.1990	OM 345.973 D	368	O 404	09.1994 → 10.1999	OM 445.934 D	372
O 371 RS	03.1986 → 03.1996	OM 345.960 D	377	O 404	09.1994 → 10.1999	OM 445.934 D	372
<b>O 373</b>				O 404	09.1994 → 10.1999	OM 445.935 D	372
373		OM 345.952 (BRA) D	368	O 404	09.1994 → 10.1999	OM 445.935 D	372
373		OM 345.960 D	377	O 404	09.1994 → 10.1999	OM 445.935 D	372
<b>O 374</b>				O 404	09.1994 → 10.1999	OM 446.934 D	439
374	11.1995 →	OM 476.977 D	401	O 404	09.1994 → 10.1999	OM 446.938 D	439
374	11.1995 →	OM 476.981 D	401	O 404	09.1994 → 10.1999	OM 446.938 D	439
<b>O 400</b>				O 404	09.1994 → 10.1999	OM 446.938 D	439
400	10.1995 →	OM 457.914 D	441	<b>O 405</b>			
400	10.1995 →	OM 457.925 D	440	GTZ	11.1986 → 02.2001	OM 602.990 D	61
400	10.1995 →	OM 457.926 D	442	GTZ	11.1986 → 02.2001	OM 602.994 D	82
400	10.1995 →	OM 457.929 D	443	O 405 G,O 405 GN,O	11.1985 →	OM 427.911 D	382
400	10.1995 →	OM 475.953 D	401	405 GTD			
400	10.1995 →	OM 475.984 D	417	O 405 G,O 405 GN,O	11.1986 →	OM 447.907 D	402
400	10.1995 →	OM 475.991 D	417	405 GTD			
400	10.1995 →	OM 475.997 D	417	O 405 G,O 405 GN,O	09.1991 →	OM 447.959 D	404
400	10.1995 →	OM 475.998 D	417	405 GTD			
400	10.1995 →	OM 476.981 D	401	O 405 G,O 405 GN,O	11.1991 →	OM 447.955 D	404
400	10.1995 →	OM 476.982 D	401	405 GTD			
400	10.1995 →	OM 476.985 D	417	O 405 G,O 405 GN,O	11.1991 →	OM 447.976 D	430
400	10.1995 →	OM 476.992 D	401	405 GTD			
400	11.1995 →	OM 476.972 D	401	O 405 G,O 405 GN,O	11.1991 →	OM 447.978 D	430
400	11.1995 →	OM 476.977 D	401	405 GTD			
400	05.1997 →	OM 475.977 D	445	O 405 G,O 405 GN,O	09.1991 →	OM 447.977 D	430
400	10.1998 →	OM 475.978 D	417	405 GTD,O 405 GNTD,O			
O 400	01.2002 → 12.2006	OM 457.925 D	440	405 GNDE			
O 400	01.2002 → 12.2006	OM 457.926 D	442	O 405 G,O 405 GN,O	09.1991 →	OM 447.984 D	404
O 400	01.2002 → 12.2006	OM 457.929 D	443	405 GTD,O 405 GNTD,O			
O 400	01.2002 → 12.2006	OM 475.953 D	401	405 GNDE			
O 400	01.2002 → 12.2006	OM 475.991 D	417	O 405 G,O 405 GN,O	09.1991 →	OM 447.998 D	430
O 400	01.2002 → 12.2006	OM 475.997 D	417	405 GTD,O 405 GNTD,O			
O 400	01.2002 → 12.2006	OM 476.972 D	401	405 GNDE			
O 400	01.2002 → 12.2006	OM 476.972 D	401	O 405 G,O 405 GN,O	09.1991 →	OM 447.999 D	431
O 400	01.2002 → 12.2006	OM 476.977 D	401	405 GTD,O 405 GNTD,O			
O 400	01.2002 → 12.2006	OM 476.977 D	401	405 GNDE			
O 400	01.2002 → 12.2006	OM 476.977 D	401	O 405 G,O 405 GN,O	11.1991 →	OM 447.979 D	430
O 400	01.2002 → 12.2006	OM 476.978 D	401	405 GTD,O 405 GNTD,O			
O 400	01.2002 → 12.2006	OM 476.981 D	401	405 GNDE			
O 400	01.2002 → 12.2006	OM 476.981 D	401	O 405 G,O 405 GN,O	11.1991 →	OM 447.980 D	404
O 400	01.2002 → 12.2006	OM 476.985 D	417	405 GTD,O 405 GNTD,O			
O 400	01.2002 → 12.2006	OM 476.985 D	417	405 GNDE			
O 400 RSD	01.1994 → 12.2003	OM 457.925 D	440	O 405 G,O 405 GTD	01.1986 → 12.1986	OM 427.950 D	399
O 400 RSE	01.1994 → 12.2003	OM 457.925 D	440	O 405 G,O 405 GTD	11.1986 →	OM 447.950 D	403
<b>O 402</b>				O 405 GN	11.1985 →	M 476.925 G	355
O 402	02.1986 → 12.1991	OM 366.917 D	208	O 405 GT	09.1991 →	OM 447.968 D	429
O 402	02.1986 → 12.1991	OM 366.965 D	195	O 405 GT	11.1991 →	OM 447.913 D	402
<b>O 403</b>				O 405 GTZ	01.1984 →	OM 602.990 D	61
O 403 RHD	01.2003 →	OM 446.938 D	439	O 405 GTZ	01.1984 →	OM 602.994 D	82
O 403 RHD	09.2003 →	OM 402.970 D	338	O 405 N, O 405 NH	11.1985 →	M 476.925 G	355
O 403 SHD	01.2003 →	OM 441.980 D	428	O 405 ST	11.1985 → 12.1986	OM 427.950 D	399
O 403 SHD	01.2003 →	OM 445.934 D	372	O 405 ST	11.1986 →	OM 447.950 D	403
O 403 SHD	09.2003 →	OM 457.944 D	454	O 405 ST	11.1986 →	OM 447.951 D	403
O 403 SHD	09.2003 →	OM 457.944 D	454	O 405 ST,O 405 N	12.1984 → 12.1986	OM 427.905 D	382
<b>O 404</b>				O 405 ST,O 405 N	12.1984 →	M 447.925 G	354
O 404	01.1991 → 12.1999	OM 442.996 D	371	O 405 ST,O 405 N	11.1985 →	OM 427.910 D	382
O 404	09.1991 → 01.1992	OM 441.921 D	503	O 405 ST,O 405 N	11.1985 →	OM 427.911 D	382
O 404	09.1991 → 01.1992	OM 441.922 D	503	O 405 ST,O 405 N	11.1985 →	OM 447.996 D	400
O 404	09.1991 → 01.1992	OM 442.930 D	504	O 405 ST,O 405 N	11.1986 → 12.1991	OM 447.905 D	402
O 404	09.1991 → 01.1992	OM 442.931 D	503	O 405 ST,O 405 N	11.1986 →	OM 447.907 D	402
				O 405 ST,O 405 N	11.1986 →	OM 447.908 D	402



				Pos					Pos
O 405 ST,O 405 N	03.1987 →	OM 447.906	D	402	1621	01.1983 →	OM 360.982	D	321
O 405 ST,O 405 N	10.1989 →	OM 447.910	D	402	1721	01.1998 → 03.2002	OM 366.984	D	190
O 405 ST,O 405 N	10.1989 →	OM 447.911	D	402	1722	08.2016 →	OM 924.911	D	290
O 405 ST,O 405 N	11.1991 → 05.1998	OM 447.913	D	402	1724	01.2012 → 03.2019	OM 926.973	D	284
O 405 ST,O 405 N	11.1991 → 05.1998	OM 447.914	D	402	8000	01.2001 →	OM 904.941	D	244
O 405 ST,O 405 N	11.1991 →	OM 447.956	D	404	OH				
O 405 ST,O 405 N	11.1991 →	OM 447.957	D	404	1113	01.1970 →	OM 344.948	D	140
O 405 ST,O 405 N	11.1991 →	OM 447.970	D	430	1314	01.1987 → 01.1997	OM 352.930	D	129
O 405 ST,O 405 N	11.1991 →	OM 447.971	D	430	1316	01.1970 →	OM 344.948	D	140
O 405 ST,O 405 N	11.1991 →	OM 447.972	D	430	1416	01.1970 →	OM 356.958	D	190
O 405 ST,O 405 N	11.1991 →	OM 447.973	D	430	1417	01.1970 →	OM 366.957	D	195
O 405 ST,O 405 N	11.1991 →	OM 447.974	D	430	1418	01.1970 →	OM 904.945	D	240
O 405 ST,O 405 N	11.1991 →	OM 447.975	D	430	1418	01.1970 →	OM 904.962	D	240
O 405 ST,O 405 N	11.1991 →	OM 447.980	D	404	1518	01.1970 →	OM 386.951	D	196
O 405 ST,O 405 N	11.1991 →	OM 447.981	D	404	1518	01.1970 →	OM 904.973	D	242
O 405 ST,O 405 N	11.1991 →	OM 447.986	D	404	1518, 1519	05.1999 →	OM 924.988	D	287
<b>O 407</b>					1520	01.1970 →	OM 386.981	D	196
O 407	03.1987 → 02.2001	OM 447.906	D	402	1521	01.1970 →	OM 386.981	D	196
O 407	03.1987 → 02.2001	OM 447.908	D	402	1521	05.2007 →	OM 924.913	D	300
O 407	09.1991 → 11.2001	OM 447.954	D	404	1525	01.1970 →	OM 906.918	D	241
O 407	11.1991 → 11.2001	OM 447.985	D	404	1526	05.2007 →	OM 926.996	D	285
O 407	11.1991 → 11.2001	OM 447.991	D	430	1618	05.1995 →	OM 904.973	D	242
O 407	1994 → 02.2001	OM 447.990	D	430	1621	05.2007 →	OM 924.913	D	300
<b>O 408</b>					1622, 1622 L	01.1970 →	OM 421.910	D	369
O 408	01.1991 → 12.1998	OM 447.908	D	402	1622, 1622 L	01.2008 → 12.2012	OM 924.913	D	300
O 408	01.1991 → 12.1998	OM 447.912	D	402	1625, 1625 L	01.1970 →	OM 422.915	D	370
O 408	11.1991 → 12.1998	OM 447.992	D	430	1626, 1626 L	05.2007 →	OM 926.996	D	285
O 408	08.1992 → 12.1998	OM 447.958	D	404	1627 L	01.1970 →	OM 440.907	D	503
O 408	08.1992 → 12.1998	OM 447.987	D	404	1628, 1628 L	01.1970 →	OM 422.918	D	370
O 408	08.1992 → 12.1998	OM 447.993	D	430	1634 L	01.1970 →	OM 440.945	D	371
<b>O 530</b>					1634 L	01.1970 →	OM 445.934	D	372
530	08.1998 →	OM 457.941	D	454	1718	05.1995 →	OM 904.973	D	242
530	08.1998 →	OM 457.943	D	446	1719LE	05.2007 →	OM 924.988	D	287
530	08.1998 →	OM 457.950	D	449	1721	05.2007 →	OM 924.913	D	300
530	08.1998 →	OM 457.951	D	449	1829L	09.1994 →	OM 445.935	D	372
530	08.1998 →	OM 457.952	D	449	<b>OMC</b>				
530	08.1998 →	OM 457.959	D	449	OMC 1419	02.2006 →	OM 904.932	D	242
530	08.1998 →	OM 457.964	D	449	OMC 1423	02.2006 →	OM 906.913	D	245
530	08.1998 →	OM 457.965	D	449	OMC 1623	02.2006 →	OM 906.913	D	245
530	08.1998 →	OM 902.925	D	251	<b>SHD</b>				
530	08.1998 →	OM 902.926	D	252	2436	12.2015 → 06.2018	OM 457.944	D	454
530	08.1998 →	OM 902.934	D	252	2441	06.2018 →	OM 457.936	D	437
530	08.1998 →	OM 926.939	D	286	<b>SK</b>				
530	04.2000 →	OM 906.961	D	254	1728, 1729, 1729 L	07.1988 → 08.1994	OM 442.906	D	504
530	04.2000 →	OM 906.962	D	254	1728, 1729, 1729 L	07.1988 → 08.1994	OM 442.907	D	504
530	04.2000 →	OM 906.963	D	257	1728, 1729, 1729 L	07.1988 → 08.1994	OM 442.908	D	504
530	05.2001 →	OM 906.960	D	245	1728, 1729, 1729 L	07.1988 → 08.1994	OM 442.923	D	504
<b>O 550</b>					1728, 1729, 1729 L	07.1988 → 08.1994	OM 442.925	D	504
Integro O 550	09.1999 → 09.2006	OM 447.903	D	459	1729 AK	07.1988 → 09.1993	OM 442.907	D	504
<b>OF</b>					1729 AK	07.1988 → 09.1993	OM 442.926	D	504
1113	01.1983 → 12.1992	OM 352.997	D	130	1729 K	07.1988 → 08.1994	OM 442.906	D	504
1113	01.1983 → 12.1992	OM 352.998	D	130	1729 K	07.1988 → 08.1994	OM 442.907	D	504
1113	01.1983 →	OM 344.949	D	169	1729 K	07.1988 → 08.1994	OM 442.925	D	504
1113	01.1983 →	OM 384.906	D	201	1729 S, 1729 LS	07.1988 → 08.1994	OM 442.906	D	504
1117	01.1983 →	OM 386.952	D	196	1729 S, 1729 LS	07.1988 → 08.1994	OM 442.907	D	504
1313, 1314	01.1983 → 12.1991	OM 352.997	D	130	1729 S, 1729 LS	07.1988 → 08.1994	OM 442.923	D	504
1317	01.1983 →	OM 327.919	D	321	1729 S, 1729 LS	07.1988 → 08.1994	OM 442.925	D	504
1317	01.1983 →	OM 360.937	D	321	1735 AK	08.1989 → 08.1994	OM 442.942	D	390
1317	01.1983 →	OM 360.951	D	321	1735 AK	08.1989 → 08.1994	OM 442.966	D	391
1413	01.1983 → 12.1991	OM 352.997	D	130	1735 K	07.1988 → 08.1994	OM 442.944	D	390
1417	01.1983 →	OM 327.940	D	321	1735 K	07.1988 → 08.1994	OM 442.963	D	391
1417	01.1983 →	OM 360.938	D	321	1735 K	07.1988 → 08.1994	OM 442.964	D	391
1417	01.1983 →	OM 360.952	D	321	1735 K	07.1988 → 08.1994	OM 442.976	D	391
1417	05.2001 → 08.2007	OM 904.920	D	242	1735 K	07.1991 → 08.1994	OM 440.940	D	412
1418	01.1988 → 05.1994	OM 904.928	D	244	1735 S, 1735 LS	07.1988 → 08.1994	OM 442.944	D	390
1519	09.2005 → 12.2011	OM 924.934	D	297	1735 S, 1735 LS	07.1988 → 08.1994	OM 442.963	D	391
1617	01.1983 →	OM 360.938	D	321	1735 S, 1735 LS	07.1988 → 08.1994	OM 442.964	D	391
1617	01.1983 →	OM 360.962	D	321	1735 S, 1735 LS	07.1988 → 08.1994	OM 442.976	D	391
1617	01.1983 →	OM 360.983	D	321	1735, 1735 L	07.1988 → 08.1994	OM 442.944	D	390

M

		Pos			Pos		
1735,1735 L	07.1988 → 08.1994	OM 442.963 D	<b>391</b>	1850 LAS	01.1991 → 09.1996	OM 440.973 D	<b>412</b>
1735,1735 L	07.1988 → 08.1994	OM 442.964 D	<b>391</b>	1850 S,1850 LS	12.1990 → 09.1996	OM 442.985 D	<b>411</b>
1735,1735 L	07.1988 → 08.1994	OM 442.976 D	<b>391</b>	1850 S,1850 LS	12.1990 → 09.1996	OM 442.989 D	<b>391</b>
1735,1735 L	12.1991 → 09.1996	OM 462.900-410 D	<b>374</b>	1850 S,1850 LS	12.1990 → 09.1996	OM 442.992 D	<b>391</b>
		(AFS)		1850 S,1850 LS	12.1990 → 09.1996	OM 442.997 D	<b>412</b>
1748 S,1748 LS	07.1988 → 09.1996	OM 442.985 D	<b>411</b>	1850 S,1850 LS	01.1991 → 09.1996	OM 440.973 D	<b>412</b>
1748 S,1748 LS	07.1988 → 09.1996	OM 442.989 D	<b>391</b>	1850,1850 L	12.1990 → 02.1991	OM 442.989 D	<b>391</b>
1748,1748 L	07.1988 → 07.1992	OM 442.989 D	<b>391</b>	1850,1850 L	12.1990 → 09.1996	OM 442.985 D	<b>411</b>
1748,1748 L	07.1988 → 09.1996	OM 442.985 D	<b>411</b>	1850,1850 L	12.1990 → 09.1996	OM 442.992 D	<b>391</b>
1831 AK	05.1991 → 09.1996	OM 401.986 D	<b>336</b>	1850,1850 L	12.1990 → 09.1996	OM 442.997 D	<b>412</b>
1831 AK	01.1994 → 09.1996	OM 445.930 D	<b>372</b>	1850,1850 L	01.1991 → 09.1996	OM 440.973 D	<b>412</b>
1831 K	07.1992 → 09.1996	OM 401.972 D	<b>336</b>	1853 AK	01.1996 → 09.1996	OM 446.920 D	<b>439</b>
1831 K	07.1992 → 09.1996	OM 401.979 D	<b>336</b>	1853 AK	01.1996 → 09.1996	OM 446.946 D	<b>436</b>
1831 K	07.1992 → 09.1996	OM 401.993 D	<b>336</b>	1853 S,1853 LS	01.1996 → 09.1996	OM 446.920 D	<b>439</b>
1831 K	07.1992 → 09.1996	OM 441.986 D	<b>418</b>	1853,1853 L	01.1996 → 09.1996	OM 446.920 D	<b>439</b>
1831 K	07.1992 → 09.1996	OM 441.993 D	<b>418</b>	1922	05.1989 → 08.1994	OM 441.905 D	<b>503</b>
1831 K	01.1994 → 09.1996	OM 445.929 D	<b>372</b>	1922	05.1989 → 08.1994	OM 441.923 D	<b>503</b>
1831 K	01.1994 → 09.1996	OM 445.937 D	<b>372</b>	1922	08.1989 → 08.1994	OM 441.914 D	<b>503</b>
1831 S,1831 LS	07.1987 → 09.1996	OM 401.993 D	<b>336</b>	1922 AK	08.1989 → 08.1994	OM 441.914 D	<b>503</b>
1831 S,1831 LS	07.1992 → 09.1996	OM 401.972 D	<b>336</b>	1922 AK	08.1989 → 08.1994	OM 441.926 D	<b>503</b>
1831 S,1831 LS	07.1992 → 09.1996	OM 401.979 D	<b>336</b>	1922 K	05.1989 → 08.1994	OM 441.905 D	<b>503</b>
1831 S,1831 LS	01.1994 → 09.1996	OM 445.929 D	<b>372</b>	1922 K	05.1989 → 08.1994	OM 441.923 D	<b>503</b>
1831 S,1831 LS	01.1994 → 09.1996	OM 445.937 D	<b>372</b>	1922 K	08.1989 → 08.1994	OM 441.914 D	<b>503</b>
1831,1831 L	07.1987 → 09.1996	OM 401.993 D	<b>336</b>	1922 S	05.1989 → 08.1994	OM 441.905 D	<b>503</b>
1831,1831 L	07.1992 → 09.1996	OM 401.972 D	<b>336</b>	1922 S	05.1989 → 08.1994	OM 441.923 D	<b>503</b>
1831,1831 L	07.1992 → 09.1996	OM 401.979 D	<b>336</b>	1922 S	08.1989 → 08.1994	OM 441.914 D	<b>503</b>
1831,1831 L	01.1994 → 09.1996	OM 445.929 D	<b>372</b>	1929 A	07.1988 → 08.1994	OM 442.906 D	<b>504</b>
1831,1831 L	01.1994 → 09.1996	OM 445.937 D	<b>372</b>	1929 A	07.1988 → 08.1994	OM 442.907 D	<b>504</b>
1834 AK	01.1991 → 09.1993	OM 441.989 D	<b>418</b>	1929 A	07.1988 → 08.1994	OM 442.909 D	<b>504</b>
1834 S,1834 LS	10.1993 → 09.1996	OM 441.986 D	<b>418</b>	1929 A	07.1988 → 08.1994	OM 442.924 D	<b>504</b>
1834 S,1834 LS	10.1993 → 09.1996	OM 441.996 D	<b>418</b>	1929 A	07.1988 → 08.1994	OM 443.940 D	<b>404</b>
1834 S,1834 LS	01.1994 → 09.1996	OM 445.920 D	<b>372</b>	1929 AK	07.1988 → 08.1994	OM 442.906 D	<b>504</b>
1834 S,1834 LS	01.1994 → 09.1996	OM 445.939 D	<b>372</b>	1929 AK	07.1988 → 08.1994	OM 442.907 D	<b>504</b>
1834,1834 L	10.1993 → 09.1996	OM 441.986 D	<b>418</b>	1929 AK	07.1988 → 08.1994	OM 442.909 D	<b>504</b>
1834,1834 L	10.1993 → 09.1996	OM 441.996 D	<b>418</b>	1929 AK	07.1988 → 08.1994	OM 442.924 D	<b>504</b>
1834,1834 L	01.1994 → 09.1996	OM 445.920 D	<b>372</b>	1929 AS	07.1988 → 08.1994	OM 442.906 D	<b>504</b>
1834,1834 L	01.1994 → 09.1996	OM 445.939 D	<b>372</b>	1929 AS	07.1988 → 08.1994	OM 442.907 D	<b>504</b>
1838 AK	12.1992 → 09.1996	OM 402.978 D	<b>338</b>	1929 AS	07.1988 → 08.1994	OM 442.926 D	<b>504</b>
1838 AK	12.1992 → 09.1996	OM 402.996 D	<b>338</b>	1929 AS	07.1988 → 08.1994	OM 442.929 D	<b>504</b>
1838 AK	01.1994 → 09.1996	OM 446.927 D	<b>439</b>	1929 K	07.1988 → 08.1994	OM 442.906 D	<b>504</b>
1838 K	12.1990 → 09.1996	OM 402.971 D	<b>338</b>	1929 K	07.1988 → 08.1994	OM 442.907 D	<b>504</b>
1838 K	01.1991 → 09.1996	OM 402.975 D	<b>338</b>	1929 K	07.1988 → 08.1994	OM 442.908 D	<b>504</b>
1838 K	03.1991 → 09.1996	OM 402.985 D	<b>338</b>	1929 K	07.1988 → 08.1994	OM 442.923 D	<b>504</b>
1838 K	06.1995 → 09.1996	OM 446.924 D	<b>439</b>	1929 K	07.1988 → 08.1994	OM 442.925 D	<b>504</b>
1838 S,1838 LS	12.1990 → 09.1996	OM 402.971 D	<b>338</b>	1929 K	08.1989 → 08.1994	OM 442.916 D	<b>504</b>
1838 S,1838 LS	12.1990 → 09.1996	OM 402.972 D	<b>338</b>	1929 S	07.1988 → 08.1994	OM 442.906 D	<b>504</b>
1838 S,1838 LS	12.1990 → 09.1996	OM 402.986 D	<b>338</b>	1929 S	07.1988 → 08.1994	OM 442.907 D	<b>504</b>
1838 S,1838 LS	01.1991 → 09.1996	OM 402.975 D	<b>338</b>	1929 S	07.1988 → 08.1994	OM 442.908 D	<b>504</b>
1838 S,1838 LS	03.1991 → 09.1996	OM 402.985 D	<b>338</b>	1929 S	07.1988 → 08.1994	OM 442.923 D	<b>504</b>
1838 S,1838 LS	06.1995 → 09.1996	OM 446.924 D	<b>439</b>	1929 S	07.1988 → 08.1994	OM 442.925 D	<b>504</b>
1838 S,1838 LS	06.1995 → 09.1996	OM 446.925 D	<b>439</b>	1929 S	08.1989 → 08.1994	OM 442.916 D	<b>504</b>
1838,1838 L	07.1987 → 09.1996	OM 402.988 D	<b>337</b>	1929,1929 L	07.1988 → 08.1994	OM 442.906 D	<b>504</b>
1838,1838 L	12.1990 → 09.1996	OM 402.971 D	<b>338</b>	1929,1929 L	07.1988 → 08.1994	OM 442.907 D	<b>504</b>
1838,1838 L	12.1990 → 09.1996	OM 402.972 D	<b>338</b>	1929,1929 L	07.1988 → 08.1994	OM 442.908 D	<b>504</b>
1838,1838 L	12.1990 → 09.1996	OM 402.986 D	<b>338</b>	1929,1929 L	07.1988 → 08.1994	OM 442.923 D	<b>504</b>
1838,1838 L	01.1991 → 09.1996	OM 402.975 D	<b>338</b>	1929,1929 L	07.1988 → 08.1994	OM 442.925 D	<b>504</b>
1838,1838 L	03.1991 → 09.1996	OM 402.985 D	<b>338</b>	1929,1929 L	08.1989 → 08.1994	OM 442.916 D	<b>504</b>
1838,1838 L	06.1995 → 09.1996	OM 446.924 D	<b>439</b>	1935	05.1989 → 10.1993	OM 442.971 D	<b>391</b>
1838,1838 L	06.1995 → 09.1996	OM 446.925 D	<b>439</b>	1935	05.1989 → 08.1994	OM 442.943 D	<b>390</b>
1840 LS	07.1991 → 07.1992	OM 402.971 D	<b>338</b>	1935	05.1989 → 08.1994	OM 442.944 D	<b>390</b>
1844 S,1844 LS	12.1990 → 09.1996	OM 440.978 D	<b>412</b>	1935	05.1989 → 08.1994	OM 442.963 D	<b>391</b>
1844 S,1844 LS	11.1991 → 09.1996	OM 440.970 D	<b>412</b>	1935	05.1989 → 08.1994	OM 442.966 D	<b>391</b>
1844 S,1844 LS	01.1994 → 09.1996	OM 446.922 D	<b>439</b>	1935	05.1989 → 08.1994	OM 442.976 D	<b>391</b>
1844,1844 L	12.1990 → 09.1996	OM 440.978 D	<b>412</b>	1935 AK	05.1989 → 10.1993	OM 442.971 D	<b>391</b>
1844,1844 L	11.1991 → 09.1996	OM 440.970 D	<b>412</b>	1935 AK	05.1989 → 10.1993	OM 442.972 D	<b>391</b>
1844,1844 L	01.1994 → 09.1996	OM 446.922 D	<b>439</b>	1935 AK	05.1989 → 08.1994	OM 442.942 D	<b>390</b>
1850 K	07.1988 → 08.1994	OM 442.997 D	<b>412</b>	1935 AK	05.1989 → 08.1994	OM 442.966 D	<b>391</b>
1850 LAS	07.1988 → 09.1996	OM 442.985 D	<b>411</b>	1935 AK	05.1989 → 08.1994	OM 442.978 D	<b>412</b>
1850 LAS	12.1988 → 09.1996	OM 442.992 D	<b>391</b>	1935 AS	05.1989 → 08.1994	OM 442.942 D	<b>390</b>

			Pos				Pos
1935 AS	05.1989 → 08.1994	OM 442.966	D 391	2050 S	01.1991 → 09.1996	OM 442.997	D 412
1935 AS	05.1989 → 08.1994	OM 442.978	D 412	2050 S	01.1994 → 09.1996	OM 446.920	D 439
1935 K	05.1989 → 08.1994	OM 442.943	D 390	2429	07.1987 → 09.1996	OM 422.916	D 370
1935 K	05.1989 → 08.1994	OM 442.944	D 390	2429	07.1988 → 08.1994	OM 442.906	D 504
1935 K	05.1989 → 08.1994	OM 442.963	D 391	2429	07.1988 → 08.1994	OM 442.907	D 504
1935 K	05.1989 → 08.1994	OM 442.964	D 391	2429	07.1988 → 08.1994	OM 442.923	D 504
1935 K	07.1991 → 08.1994	OM 440.940	D 412	2429	07.1988 → 08.1994	OM 442.925	D 504
1935 K	07.1991 → 08.1994	OM 442.977	D 412	2429 K	07.1988 → 08.1994	OM 442.906	D 504
1935 S	05.1989 → 08.1994	OM 442.943	D 390	2429 K	07.1988 → 08.1994	OM 442.907	D 504
1935 S	05.1989 → 08.1994	OM 442.944	D 390	2429 K	07.1988 → 08.1994	OM 442.923	D 504
1935 S	05.1989 → 08.1994	OM 442.963	D 391	2429 K	07.1988 → 08.1994	OM 442.925	D 504
1935 S	05.1989 → 08.1994	OM 442.976	D 391	2429 S	07.1988 → 08.1994	OM 442.906	D 504
1945 AK	07.1988 → 08.1994	OM 443.940	D 404	2429 S	07.1988 → 08.1994	OM 442.907	D 504
1948	09.1988 → 07.1992	OM 442.982	D 391	2429 S	07.1988 → 08.1994	OM 442.925	D 504
1948	09.1988 → 07.1992	OM 442.984	D 391	2429 S,2429 LS	07.1988 → 08.1994	OM 442.906	D 504
1948	09.1988 → 07.1992	OM 442.985	D 411	2429 S,2429 LS	07.1988 → 08.1994	OM 442.907	D 504
1948	09.1988 → 07.1992	OM 442.989	D 391	2429 S,2429 LS	07.1988 → 08.1994	OM 442.925	D 504
2024	02.1993 → 09.1996	OM 401.975	D 336	2429, 2429 L	07.1987 → 08.1994	OM 442.908	D 504
2024	01.1994 → 09.1996	OM 445.924	D 372	2429, 2429 L	07.1988 → 08.1994	OM 442.906	D 504
2024 AK	02.1993 → 09.1996	OM 401.984	D 336	2429, 2429 L	07.1988 → 08.1994	OM 442.907	D 504
2024 AK	01.1994 → 09.1996	OM 445.925	D 372	2429, 2429 L	07.1988 → 08.1994	OM 442.923	D 504
2024 K	02.1993 → 09.1996	OM 401.975	D 336	2429, 2429 L	07.1988 → 08.1994	OM 442.925	D 504
2024 K	01.1994 → 09.1996	OM 445.924	D 372	2429, 2429 L	08.1989 → 08.1994	OM 442.916	D 504
2027 AK	02.1993 → 07.1992	OM 401.989	D 336	2429,2429 L	07.1988 → 08.1994	OM 442.906	D 504
2027 AK	02.1993 → 09.1996	OM 445.933	D 372	2429,2429 L	07.1988 → 08.1994	OM 442.907	D 504
2031	03.1992 → 09.1996	OM 401.972	D 336	2429,2429 L	07.1988 → 08.1994	OM 442.925	D 504
2031	03.1992 → 09.1996	OM 401.979	D 336	2434 L	01.1991 → 09.1996	OM 441.986	D 418
2031	03.1992 → 09.1996	OM 401.993	D 336	2434 L	01.1991 → 09.1996	OM 441.989	D 418
2031 A	03.1992 → 09.1996	OM 401.986	D 336	2435	09.1987 → 03.1991	OM 442.962	D 391
2031 A	03.1992 → 09.1996	OM 402.978	D 338	2435	07.1988 → 08.1994	OM 442.942	D 390
2031 A	03.1992 → 09.1996	OM 402.996	D 338	2435	07.1988 → 08.1994	OM 442.943	D 390
2031 A	03.1992 → 09.1996	OM 440.979	D 412	2435	07.1988 → 08.1994	OM 442.944	D 390
2031 A	01.1994 → 09.1996	OM 445.930	D 372	2435	07.1988 → 08.1994	OM 442.944	D 390
2031 A	01.1994 → 09.1996	OM 446.927	D 439	2435	07.1988 → 08.1994	OM 442.963	D 391
2031 AS	03.1992 → 09.1996	OM 401.986	D 336	2435	07.1988 → 08.1994	OM 442.963	D 391
2031 K	03.1992 → 09.1996	OM 401.972	D 336	2435	07.1988 → 08.1994	OM 442.964	D 391
2031 K	03.1992 → 09.1996	OM 401.979	D 336	2435	07.1988 → 08.1994	OM 442.965	D 391
2031 K	03.1992 → 09.1996	OM 401.993	D 336	2435	07.1988 → 08.1994	OM 442.966	D 391
2031 K	01.1994 → 09.1996	OM 445.929	D 372	2435	07.1988 → 08.1994	OM 442.976	D 391
2031 S	03.1992 → 09.1996	OM 401.972	D 336	2435	07.1988 → 08.1994	OM 442.976	D 391
2031 S	03.1992 → 09.1996	OM 401.979	D 336	2435	05.1989 → 08.1994	OM 442.978	D 412
2031 S	03.1992 → 09.1996	OM 401.993	D 336	2435	12.1991 → 08.1994	OM 440.941	D 412
2038	11.1991 → 09.1996	OM 402.971	D 338	2435	12.1991 → 08.1994	OM 440.942	D 412
2038	11.1991 → 09.1996	OM 402.972	D 338	2435 K	07.1988 → 08.1994	OM 442.943	D 390
2038	11.1991 → 09.1996	OM 402.985	D 338	2435 K	07.1988 → 08.1994	OM 442.944	D 390
2038	11.1991 → 09.1996	OM 402.986	D 338	2435 K	07.1988 → 08.1994	OM 442.963	D 391
2038	03.1992 → 09.1996	OM 402.996	D 338	2435 K	07.1988 → 08.1994	OM 442.964	D 391
2038	01.1994 → 09.1996	OM 446.925	D 439	2435 K	07.1988 → 08.1994	OM 442.965	D 391
2038	01.1994 → 09.1996	OM 446.927	D 439	2435 K	07.1991 → 08.1994	OM 440.940	D 412
2038 AS	12.1992 → 09.1996	OM 402.978	D 338	2435 LS	07.1988 → 08.1994	OM 442.944	D 390
2038 AS	01.1994 → 09.1996	OM 446.927	D 439	2435 LS	07.1988 → 08.1994	OM 442.963	D 391
2038 S	11.1991 → 09.1996	OM 402.971	D 338	2435 LS	07.1988 → 08.1994	OM 442.976	D 391
2038 S	11.1991 → 09.1996	OM 402.985	D 338	2435 S	07.1988 → 08.1994	OM 442.943	D 390
2044	01.1992 → 09.1996	OM 440.970	D 412	2435 S	07.1988 → 08.1994	OM 442.944	D 390
2044	01.1992 → 09.1996	OM 440.978	D 412	2435 S	07.1988 → 08.1994	OM 442.963	D 391
2044	01.1994 → 09.1996	OM 446.922	D 439	2435 S	07.1988 → 08.1994	OM 442.964	D 391
2044 AS	01.1994 → 09.1996	OM 440.970	D 412	2435 S	07.1988 → 08.1994	OM 442.965	D 391
2044 AS	01.1994 → 09.1996	OM 440.979	D 412	2435 S	07.1988 → 08.1994	OM 442.976	D 391
2044 S	01.1992 → 09.1996	OM 440.970	D 412	2435 S	07.1991 → 08.1994	OM 440.940	D 412
2044 S	01.1994 → 09.1996	OM 446.922	D 439	2435 S,2435 LS	07.1988 → 08.1994	OM 442.943	D 390
2050	01.1991 → 02.1991	OM 442.989	D 391	2435 S,2435 LS	07.1988 → 08.1994	OM 442.943	D 390
2050	01.1991 → 09.1996	OM 442.985	D 411	2435 S,2435 LS	07.1988 → 08.1994	OM 442.944	D 390
2050	01.1991 → 09.1996	OM 442.992	D 391	2435 S,2435 LS	07.1988 → 08.1994	OM 442.944	D 390
2050	01.1991 → 09.1996	OM 442.997	D 412	2435 S,2435 LS	07.1988 → 08.1994	OM 442.963	D 391
2050	01.1994 → 09.1996	OM 446.920	D 439	2435 S,2435 LS	07.1988 → 08.1994	OM 442.963	D 391
2050 S	01.1991 → 09.1996	OM 440.976	D 413	2435 S,2435 LS	07.1988 → 08.1994	OM 442.964	D 391
2050 S	01.1991 → 09.1996	OM 442.985	D 411	2435 S,2435 LS	07.1988 → 08.1994	OM 442.964	D 391
2050 S	01.1991 → 09.1996	OM 442.989	D 391	2435 S,2435 LS	07.1988 → 08.1994	OM 442.965	D 391
2050 S	01.1991 → 09.1996	OM 442.992	D 391	2435 S,2435 LS	07.1988 → 08.1994	OM 442.965	D 391

M



		Pos			Pos		
2435 S,2435 LS	07.1988 → 08.1994	OM 442.968 D	<b>391</b>	2538,2538 L	03.1991 → 09.1996	OM 402.972 D	<b>338</b>
2435 S,2435 LS	07.1988 → 08.1994	OM 442.968 D	<b>391</b>	2538,2538 L	03.1991 → 09.1996	OM 402.975 D	<b>338</b>
2435 S,2435 LS	07.1988 → 08.1994	OM 442.976 D	<b>391</b>	2538,2538 L	03.1991 → 09.1996	OM 402.985 D	<b>338</b>
2435 S,2435 LS	07.1988 → 08.1994	OM 442.976 D	<b>391</b>	2538,2538 L	03.1991 → 09.1996	OM 402.986 D	<b>338</b>
2435,2435 L	07.1988 → 08.1994	OM 442.943 D	<b>390</b>	2538,2538 L	02.1992 → 09.1996	OM 402.989 D	<b>338</b>
2435,2435 L	07.1988 → 08.1994	OM 442.944 D	<b>390</b>	2538,2538 L	01.1994 → 09.1996	OM 446.924 D	<b>439</b>
2435,2435 L	07.1988 → 08.1994	OM 442.963 D	<b>391</b>	2538,2538 L	01.1994 → 09.1996	OM 446.925 D	<b>439</b>
2435,2435 L	07.1988 → 08.1994	OM 442.964 D	<b>391</b>	2544	01.1994 → 09.1996	OM 440.970 D	<b>412</b>
2435,2435 L	07.1988 → 08.1994	OM 442.965 D	<b>391</b>	2544	01.1994 → 09.1996	OM 440.978 D	<b>412</b>
2435,2435 L	07.1988 → 08.1994	OM 442.968 D	<b>391</b>	2544 LS	01.1992 → 09.1996	OM 440.970 D	<b>412</b>
2435,2435 L	07.1988 → 08.1994	OM 442.976 D	<b>391</b>	2544 LS	01.1992 → 09.1996	OM 440.978 D	<b>412</b>
2435,2435 L	12.1991 → 09.1996	OM 462.900-410 (AFS)	<b>374</b>	2544 LS	01.1994 → 09.1996	OM 446.942 D	<b>436</b>
2435,2435 L	12.1991 → 09.1996	OM 462.900-411 (AFS)	<b>407</b>	2544 S	07.1988 → 08.1994	OM 440.970 D	<b>412</b>
2448	07.1988 → 07.1992	OM 442.985 D	<b>411</b>	2544, 2544 L	01.1992 → 09.1996	OM 440.970 D	<b>412</b>
2448	12.1988 → 07.1992	OM 442.992 D	<b>391</b>	2544, 2544 L	01.1992 → 09.1996	OM 440.978 D	<b>412</b>
2448 LS	07.1988 → 07.1992	OM 442.984 D	<b>391</b>	2544,2544 L	12.1990 → 09.1996	OM 446.922 D	<b>439</b>
2448 LS	07.1988 → 07.1992	OM 442.985 D	<b>411</b>	2544,2544 L	01.1992 → 09.1996	OM 440.978 D	<b>412</b>
2448 LS	07.1988 → 07.1992	OM 442.989 D	<b>391</b>	2544,2544 L	01.1994 → 09.1996	OM 440.970 D	<b>412</b>
2448 S	07.1988 → 07.1992	OM 442.985 D	<b>411</b>	2550	07.1988 → 09.1996	OM 446.922 D	<b>439</b>
2448 S	07.1988 → 07.1992	OM 442.989 D	<b>391</b>	2550	07.1988 → 09.1996	OM 442.989 D	<b>391</b>
2448 S	12.1988 → 07.1992	OM 442.992 D	<b>391</b>	2550	07.1988 → 09.1996	OM 442.997 D	<b>412</b>
2448,2448 L	07.1988 → 07.1992	OM 442.984 D	<b>391</b>	2550	01.1991 → 09.1996	OM 440.971 D	<b>413</b>
2448,2448 L	07.1988 → 07.1992	OM 442.989 D	<b>391</b>	2550	01.1991 → 09.1996	OM 440.973 D	<b>412</b>
2448,2448 L	07.1988 → 09.1996	OM 442.985 D	<b>411</b>	2550 K	07.1988 → 09.1996	OM 440.971 D	<b>413</b>
2531	05.1991 → 09.1996	OM 401.986 D	<b>336</b>	2550 K	07.1988 → 09.1996	OM 442.989 D	<b>391</b>
2531	01.1994 → 09.1996	OM 445.930 D	<b>372</b>	2550 K	07.1988 → 09.1996	OM 442.997 D	<b>412</b>
2531, 2531 L	07.1987 → 09.1996	OM 401.993 D	<b>336</b>	2550 K	09.1991 → 09.1996	OM 440.981 D	<b>412</b>
2531, 2531 L	07.1988 → 09.1996	OM 401.979 D	<b>336</b>	2550 S, 2550 LS	01.1991 → 09.1996	OM 440.971 D	<b>413</b>
2531, 2531 L	05.1991 → 09.1996	OM 401.986 D	<b>336</b>	2550 S, 2550 LS	01.1991 → 09.1996	OM 440.973 D	<b>412</b>
2531, 2531 L	01.1994 → 09.1996	OM 445.929 D	<b>372</b>	2550 S, 2550 LS	01.1991 → 09.1996	OM 442.997 D	<b>412</b>
2531, 2531 L	01.1994 → 09.1996	OM 445.930 D	<b>372</b>	2550 S, 2550 LS	07.1991 → 09.1996	OM 442.998 D	<b>412</b>
2531, 2531 L	01.1994 → 09.1996	OM 445.937 D	<b>372</b>	2550 S, 2550 LS	01.1994 → 09.1996	OM 446.920 D	<b>439</b>
2534, 2534 L	01.1991 → 09.1996	OM 441.986 D	<b>418</b>	2550,2550 L	01.1991 → 09.1996	OM 440.971 D	<b>413</b>
2534, 2534 L	10.1993 → 09.1996	OM 441.996 D	<b>418</b>	2550,2550 L	01.1991 → 09.1996	OM 440.973 D	<b>412</b>
2534, 2534 L	01.1994 → 09.1996	OM 445.920 D	<b>372</b>	2550,2550 L	01.1991 → 09.1996	OM 442.997 D	<b>412</b>
2534, 2534 L	01.1994 → 09.1996	OM 445.939 D	<b>372</b>	2550,2550 L	07.1991 → 09.1996	OM 442.998 D	<b>412</b>
2538	03.1991 → 09.1996	OM 402.971 D	<b>338</b>	2550,2550 L	01.1994 → 09.1996	OM 446.920 D	<b>439</b>
2538	03.1991 → 09.1996	OM 402.972 D	<b>338</b>	2553 S, 2553 LS	01.1996 → 09.1996	OM 446.920 D	<b>439</b>
2538	03.1991 → 09.1996	OM 402.975 D	<b>338</b>	2553,2553 L	01.1996 → 09.1996	OM 446.920 D	<b>439</b>
2538	03.1991 → 09.1996	OM 402.985 D	<b>338</b>	2629	07.1988 → 08.1994	OM 442.906 D	<b>504</b>
2538	03.1991 → 09.1996	OM 402.986 D	<b>338</b>	2629	07.1988 → 08.1994	OM 442.907 D	<b>504</b>
2538	03.1991 → 09.1996	OM 402.986 D	<b>338</b>	2629	07.1988 → 08.1994	OM 442.917 D	<b>504</b>
2538	03.1991 → 09.1996	OM 402.986 D	<b>338</b>	2629	07.1988 → 08.1994	OM 442.925 D	<b>504</b>
2538	03.1991 → 09.1996	OM 440.970 D	<b>412</b>	2629	07.1988 → 08.1994	OM 442.926 D	<b>504</b>
2538	03.1991 → 09.1996	OM 440.978 D	<b>412</b>	2629	07.1988 → 08.1994	OM 442.926 D	<b>504</b>
2538	03.1991 → 09.1996	OM 440.980 D	<b>424</b>	2629	07.1988 → 08.1994	OM 442.929 D	<b>504</b>
2538	02.1992 → 09.1996	OM 402.989 D	<b>338</b>	2629	07.1988 → 08.1994	OM 442.959 D	<b>390</b>
2538	01.1994 → 09.1996	OM 446.924 D	<b>439</b>	2629	07.1988 → 08.1994	OM 442.959 D	<b>390</b>
2538	01.1994 → 09.1996	OM 446.925 D	<b>439</b>	2629	07.1988 → 08.1994	OM 462.900-011 (AFS)	<b>508</b>
2538 K, 2538 LK	03.1991 → 09.1996	OM 402.971 D	<b>338</b>	2629 A	07.1988 → 08.1994	OM 440.970 D	<b>412</b>
2538 K, 2538 LK	03.1991 → 09.1996	OM 402.972 D	<b>338</b>	2629 A	07.1988 → 08.1994	OM 440.971 D	<b>413</b>
2538 K, 2538 LK	03.1991 → 09.1996	OM 402.975 D	<b>338</b>	2629 A	07.1988 → 08.1994	OM 442.907 D	<b>504</b>
2538 K, 2538 LK	03.1991 → 09.1996	OM 402.985 D	<b>338</b>	2629 A	07.1988 → 08.1994	OM 442.926 D	<b>504</b>
2538 K, 2538 LK	03.1991 → 09.1996	OM 402.986 D	<b>338</b>	2629 A	07.1988 → 08.1994	OM 442.942 D	<b>390</b>
2538 K, 2538 LK	03.1991 → 09.1996	OM 402.986 D	<b>338</b>	2629 A	07.1988 → 08.1994	OM 442.959 D	<b>390</b>
2538 K, 2538 LK	02.1992 → 09.1996	OM 402.989 D	<b>338</b>	2629 A	07.1988 → 08.1994	OM 442.966 D	<b>391</b>
2538 K, 2538 LK	01.1994 → 09.1996	OM 446.924 D	<b>439</b>	2629 A	07.1988 → 08.1994	OM 442.966 D	<b>391</b>
2538 K, 2538 LK	01.1994 → 09.1996	OM 446.925 D	<b>439</b>	2629 A	07.1988 → 08.1994	OM 442.989 D	<b>391</b>
2538 S,2538 LS	03.1991 → 09.1996	OM 402.971 D	<b>338</b>	2629 A	07.1988 → 08.1994	OM 442.997 D	<b>412</b>
2538 S,2538 LS	03.1991 → 09.1996	OM 402.972 D	<b>338</b>	2629 A	07.1988 → 08.1994	OM 443.940 D	<b>404</b>
2538 S,2538 LS	03.1991 → 09.1996	OM 402.975 D	<b>338</b>	2629 A	03.1991 → 08.1994	OM 402.982 D	<b>338</b>
2538 S,2538 LS	03.1991 → 09.1996	OM 402.985 D	<b>338</b>	2629 AK	07.1988 → 08.1994	OM 440.970 D	<b>412</b>
2538 S,2538 LS	03.1991 → 09.1996	OM 402.986 D	<b>338</b>	2629 AK	07.1988 → 08.1994	OM 440.971 D	<b>413</b>
2538 S,2538 LS	03.1991 → 09.1996	OM 402.986 D	<b>338</b>	2629 AK	07.1988 → 08.1994	OM 442.907 D	<b>504</b>
2538 S,2538 LS	02.1992 → 09.1996	OM 402.989 D	<b>338</b>	2629 AK	07.1988 → 08.1994	OM 442.926 D	<b>504</b>
2538 S,2538 LS	02.1992 → 09.1996	OM 402.990 D	<b>338</b>	2629 AK	07.1988 → 08.1994	OM 442.942 D	<b>390</b>
2538 S,2538 LS	01.1994 → 09.1996	OM 446.924 D	<b>439</b>	2629 AK	07.1988 → 08.1994	OM 442.942 D	<b>390</b>
2538 S,2538 LS	01.1994 → 09.1996	OM 446.925 D	<b>439</b>	2629 AK	07.1988 → 08.1994	OM 442.959 D	<b>390</b>
2538 S,2538 LS	01.1994 → 09.1996	OM 446.928 D	<b>439</b>	2629 AK	07.1988 → 08.1994	OM 442.966 D	<b>391</b>
2538 S,2538 LS	01.1994 → 09.1996	OM 446.929 D	<b>439</b>	2629 AK	07.1988 → 08.1994	OM 442.966 D	<b>391</b>
2538,2538 L	03.1991 → 09.1996	OM 402.971 D	<b>338</b>	2629 AK	07.1988 → 08.1994	OM 442.989 D	<b>391</b>
				2629 AS	07.1988 → 08.1994	OM 442.997 D	<b>412</b>
						OM 442.907 D	<b>504</b>

			Pos				Pos
2629 AS	07.1988 → 08.1994	OM 442.926	D 504	2635 AS	02.1992 → 10.1993	OM 442.972	D 391
2629 AS	07.1988 → 08.1994	OM 442.989	D 391	2635 AS	02.1992 → 08.1994	OM 440.941	D 412
2629 AS	07.1988 → 08.1994	OM 442.997	D 412	2635 AS	02.1992 → 08.1994	OM 440.942	D 412
2629 K	07.1988 → 08.1994	OM 401.979	D 336	2635 AS	02.1992 → 08.1994	OM 442.942	D 390
2629 K	07.1988 → 08.1994	OM 442.906	D 504	2635 AS	02.1992 → 08.1994	OM 442.966	D 391
2629 K	07.1988 → 08.1994	OM 442.907	D 504	2635 K	07.1988 → 08.1994	OM 442.944	D 390
2629 K	07.1988 → 08.1994	OM 442.917	D 504	2635 K	07.1988 → 08.1994	OM 442.964	D 391
2629 K	07.1988 → 08.1994	OM 442.925	D 504	2635 K	07.1988 → 08.1994	OM 442.966	D 391
2629 K	07.1988 → 08.1994	OM 442.926	D 504	2635 K	07.1988 → 08.1994	OM 442.989	D 391
2629 K	07.1988 → 08.1994	OM 442.929	D 504	2635 K	07.1988 → 08.1994	OM 442.994	D 414
2629 K	07.1988 → 08.1994	OM 442.989	D 391	2635 K	07.1988 → 08.1994	OM 442.997	D 412
2629 S	07.1988 → 08.1994	OM 442.906	D 504	2635 K	01.1991 → 08.1994	OM 402.971	D 338
2629 S	07.1988 → 08.1994	OM 442.907	D 504	2635 K	07.1991 → 08.1994	OM 440.940	D 412
2629 S	07.1988 → 08.1994	OM 442.917	D 504	2635 K	07.1991 → 08.1994	OM 440.970	D 412
2629 S	07.1988 → 08.1994	OM 442.925	D 504	2635 S	07.1988 → 08.1994	OM 442.944	D 390
2629 S	07.1988 → 08.1994	OM 442.926	D 504	2635 S	07.1988 → 08.1994	OM 442.964	D 391
2629 S	07.1988 → 08.1994	OM 442.929	D 504	2635 S	07.1988 → 08.1994	OM 442.966	D 391
2631	06.1992 → 09.1996	OM 401.972	D 336	2635 S	07.1988 → 08.1994	OM 442.989	D 391
2631	06.1992 → 09.1996	OM 401.979	D 336	2635 S	07.1988 → 08.1994	OM 442.994	D 414
2631	06.1992 → 09.1996	OM 401.981	D 336	2635 S	07.1988 → 08.1994	OM 442.997	D 412
2631	06.1992 → 09.1996	OM 401.987	D 336	2635 S	07.1991 → 08.1994	OM 440.940	D 412
2631	06.1992 → 09.1996	OM 401.993	D 336	2638 A, LA	09.1991 → 09.1996	OM 402.975	D 338
2631	06.1992 → 09.1996	OM 441.998	D 418	2638 A, LA	09.1991 → 09.1996	OM 440.970	D 412
2631	01.1994 → 09.1996	OM 445.920	D 372	2638 A, LA	03.1992 → 09.1996	OM 402.978	D 338
2631	01.1994 → 09.1996	OM 445.929	D 372	2638 A, LA	03.1992 → 09.1996	OM 402.996	D 338
2631	01.1994 → 09.1996	OM 445.930	D 372	2638 A, LA	03.1992 → 09.1996	OM 440.979	D 412
2631	01.1994 → 09.1996	OM 445.931	D 372	2638 A, LA	01.1994 → 09.1996	OM 446.927	D 439
2631 A	06.1992 → 09.1996	OM 401.986	D 336	2638 AK	07.1992 → 09.1996	OM 402.975	D 338
2631 A	01.1994 → 09.1996	OM 445.930	D 372	2638 AK	07.1992 → 09.1996	OM 402.978	D 338
2631 AK, 2634 AK	06.1992 → 09.1996	OM 401.986	D 336	2638 AK	07.1992 → 09.1996	OM 402.996	D 338
2631 AK, 2634 AK	01.1994 → 09.1996	OM 445.930	D 372	2638 AK	01.1994 → 09.1996	OM 446.927	D 439
2631 AS	06.1992 → 09.1996	OM 401.986	D 336	2638 AS	07.1992 → 09.1996	OM 402.975	D 338
2631 K	07.1988 → 08.1994	OM 401.979	D 336	2638 AS	07.1992 → 09.1996	OM 402.978	D 338
2631 K	07.1988 → 08.1994	OM 401.993	D 336	2638 AS	07.1992 → 09.1996	OM 402.996	D 338
2631 K	12.1990 → 08.1994	OM 401.972	D 336	2638 AS	01.1994 → 09.1996	OM 446.927	D 439
2631 K	02.1992 → 08.1994	OM 441.998	D 418	2638 K	09.1991 → 09.1996	OM 402.971	D 338
2631 K	01.1994 → 08.1994	OM 445.929	D 372	2638 K	09.1991 → 09.1996	OM 402.972	D 338
2631 S	06.1992 → 09.1996	OM 401.972	D 336	2638 K	09.1991 → 09.1996	OM 402.975	D 338
2631 S	06.1992 → 09.1996	OM 401.979	D 336	2638 K	09.1991 → 09.1996	OM 402.985	D 338
2631 S	06.1992 → 09.1996	OM 401.981	D 336	2638 K	09.1991 → 09.1996	OM 402.986	D 338
2631 S	06.1992 → 09.1996	OM 401.987	D 336	2638 K	09.1991 → 09.1996	OM 440.990	D 424
2631 S	06.1992 → 09.1996	OM 401.993	D 336	2638 K	01.1994 → 09.1996	OM 446.924	D 439
2631 S	06.1992 → 09.1996	OM 441.998	D 418	2638 K	01.1994 → 09.1996	OM 446.925	D 439
2631 S	01.1994 → 09.1996	OM 445.929	D 372	2638 K	01.1994 → 09.1996	OM 446.926	D 439
2631 S	01.1994 → 09.1996	OM 445.930	D 372	2638, 2638 L	09.1991 → 09.1996	OM 402.971	D 338
2631 S	01.1994 → 09.1996	OM 445.931	D 372	2638, 2638 L	09.1991 → 09.1996	OM 402.972	D 338
2634	01.1994 → 09.1996	OM 445.920	D 372	2638, 2638 L	09.1991 → 09.1996	OM 402.975	D 338
2634 S	06.1992 → 09.1996	OM 441.986	D 418	2638, 2638 L	09.1991 → 09.1996	OM 402.985	D 338
2635	07.1988 → 08.1994	OM 442.909	D 504	2638, 2638 L	09.1991 → 09.1996	OM 402.986	D 338
2635	07.1988 → 08.1994	OM 442.923	D 504	2638, 2638 L	09.1991 → 09.1996	OM 440.990	D 424
2635	07.1988 → 08.1994	OM 442.944	D 390	2638, 2638 L	01.1994 → 09.1996	OM 446.924	D 439
2635	07.1988 → 08.1994	OM 442.964	D 391	2638, 2638 L	01.1994 → 09.1996	OM 446.925	D 439
2635	07.1988 → 08.1994	OM 442.966	D 391	2638, 2638 L	01.1994 → 09.1996	OM 446.926	D 439
2635	07.1988 → 08.1994	OM 442.976	D 391	2644 A	01.1992 → 09.1996	OM 440.970	D 412
2635	01.1991 → 08.1994	OM 442.997	D 412	2644 A	03.1992 → 09.1996	OM 440.979	D 412
2635 A	02.1990 → 10.1993	OM 442.972	D 391	2644 A	01.1994 → 09.1996	OM 446.936	D 439
2635 A	02.1990 → 08.1994	OM 442.942	D 390	2644 S	01.1992 → 09.1996	OM 440.970	D 412
2635 A	02.1990 → 08.1994	OM 442.966	D 391	2644 S	01.1994 → 09.1996	OM 446.922	D 439
2635 A	12.1991 → 08.1994	OM 440.970	D 412	2644, 2644 L	01.1992 → 09.1996	OM 440.970	D 412
2635 AK	02.1990 → 10.1993	OM 442.972	D 391	2644, 2644 L	01.1994 → 09.1996	OM 440.978	D 412
2635 AK	02.1990 → 08.1994	OM 440.971	D 413	2644, 2644 L	01.1994 → 09.1996	OM 446.922	D 439
2635 AK	02.1990 → 08.1994	OM 442.942	D 390	2645 AS	02.1990 → 09.1996	OM 442.989	D 391
2635 AK	02.1990 → 08.1994	OM 442.966	D 391	2648 AK	02.1990 → 08.1994	OM 442.989	D 391
2635 AK	02.1990 → 08.1994	OM 442.989	D 391	2648 AK	01.1991 → 08.1994	OM 440.973	D 412
2635 AK	02.1990 → 08.1994	OM 442.997	D 412	2648 AS	07.1988 → 08.1994	OM 442.989	D 391
2635 AK	01.1991 → 08.1994	OM 440.973	D 412	2648 AS	07.1988 → 08.1994	OM 442.997	D 412
2635 AK	12.1991 → 08.1994	OM 440.941	D 412	2648 S	12.1988 → 07.1992	OM 442.983	D 391
2635 AK	12.1991 → 08.1994	OM 440.942	D 412	2648 S	12.1988 → 07.1992	OM 442.985	D 411
2635 AS	02.1990 → 09.1996	OM 442.989	D 391	2648 S	12.1988 → 07.1992	OM 442.989	D 391

M



			Pos				Pos
2648 S	12.1988 → 07.1992	OM 442.992	D 391	3238, 3238 L	01.1994 → 09.1996	OM 446.926	D 439
2648 S	12.1988 → 07.1992	OM 442.994	D 414	3244	01.1994 → 09.1996	OM 440.970	D 412
2650 A	07.1992 → 09.1996	OM 440.982	D 412	3244	01.1994 → 09.1996	OM 440.980	D 424
2650 AK	07.1988 → 08.1994	OM 440.971	D 413	3244	01.1994 → 09.1996	OM 446.939	D 439
2650 AK	07.1988 → 08.1994	OM 442.989	D 391	3244 L	07.1988 → 09.1996	OM 440.970	D 412
2650 AK	07.1988 → 08.1994	OM 442.997	D 412	3244 L	01.1994 → 09.1996	OM 446.922	D 439
2650 AS	01.1994 → 09.1996	OM 440.971	D 413	3248	07.1988 → 07.1992	OM 442.984	D 391
2650 AS	01.1994 → 09.1996	OM 440.982	D 412	3248	07.1988 → 09.1996	OM 442.985	D 411
2650 AS	01.1994 → 09.1996	OM 442.989	D 391	3250 L	07.1988 → 09.1996	OM 440.971	D 413
2650 AS	01.1994 → 09.1996	OM 442.997	D 412	3250 L	07.1988 → 09.1996	OM 442.997	D 412
2650 K	07.1988 → 08.1994	OM 442.989	D 391	3250 L	01.1991 → 09.1996	OM 440.973	D 412
2650 K	07.1988 → 08.1994	OM 442.994	D 414	3250 L	03.1991 → 09.1996	OM 440.975	D 413
2650 K	07.1988 → 08.1994	OM 442.997	D 412	3253, 3253 L	01.1996 → 09.1996	OM 446.920	D 439
2650 S	07.1992 → 09.1996	OM 440.971	D 413	3253, 3253 L	01.1996 → 09.1996	OM 446.933	D 372
2650 S	07.1992 → 09.1996	OM 440.973	D 412	3253, 3253 L	01.1996 → 09.1996	OM 446.945	D 436
2650 S	07.1992 → 09.1996	OM 442.997	D 412	3529	07.1988 → 08.1994	OM 442.906	D 504
2650, 2650 L	07.1992 → 02.1991	OM 442.989	D 391	3529	07.1988 → 08.1994	OM 442.907	D 504
2650, 2650 L	07.1992 → 06.1995	OM 440.981	D 412	3529	07.1988 → 08.1994	OM 442.925	D 504
2650, 2650 L	07.1992 → 09.1996	OM 440.973	D 412	3534 K	10.1993 → 09.1996	OM 441.988	D 418
2650, 2650 L	07.1992 → 09.1996	OM 442.997	D 412	3534 K	01.1994 → 09.1996	OM 445.922	D 372
2653, 2653 L	09.1995 → 09.1996	OM 446.920	D 439	3535	07.1988 → 08.1994	OM 442.942	D 390
2653 AK	07.1992 → 09.1996	OM 446.946	D 436	3535	07.1988 → 08.1994	OM 442.944	D 390
3050	01.1994 → 09.1996	OM 446.933	D 372	3535	07.1988 → 08.1994	OM 442.959	D 390
3053 S	12.1993 → 09.1996	OM 440.976	D 413	3535	07.1988 → 08.1994	OM 442.964	D 391
3229	09.1989 → 08.1994	OM 442.915	D 504	3535	07.1988 → 08.1994	OM 442.966	D 391
3229	09.1989 → 08.1994	OM 442.916	D 504	3535 AK	02.1990 → 08.1994	OM 442.946	D 390
3229	09.1989 → 08.1994	OM 442.927	D 504	3535 AK	02.1990 → 08.1994	OM 442.957	D 390
3229	09.1989 → 08.1994	OM 442.928	D 504	3535 AK	03.1991 → 08.1994	OM 402.982	D 338
3229 K	09.1989 → 01.1992	OM 442.915	D 504	3535 AK	03.1991 → 08.1994	OM 402.983	D 338
3229 K	09.1989 → 01.1992	OM 442.916	D 504	3535 K	07.1988 → 08.1994	OM 442.942	D 390
3229 K	09.1989 → 01.1992	OM 442.923	D 504	3535 K	07.1988 → 08.1994	OM 442.966	D 391
3229 K	09.1989 → 01.1992	OM 442.927	D 504	3535 K	10.1988 → 08.1994	OM 442.945	D 390
3229 K	09.1989 → 01.1992	OM 442.928	D 504	3535 K	10.1988 → 08.1994	OM 442.959	D 390
3233 K	10.1990 → 07.1992	OM 441.982	D 404	3535 K	10.1988 → 08.1994	OM 442.989	D 391
3234 K	02.1992 → 09.1996	OM 441.988	D 418	3535 K	03.1991 → 08.1994	OM 402.982	D 338
3234 K	02.1992 → 09.1996	OM 441.990	D 418	3535 K	03.1991 → 08.1994	OM 402.983	D 338
3234 K	02.1992 → 09.1996	OM 441.992	D 418	3535 S	07.1988 → 08.1994	OM 442.944	D 390
3234 K	01.1994 → 09.1996	OM 445.922	D 372	3535 S	07.1988 → 08.1994	OM 442.964	D 391
3235	07.1988 → 08.1994	OM 442.944	D 390	3535 S	07.1991 → 08.1994	OM 440.940	D 412
3235	07.1988 → 08.1994	OM 442.963	D 391	3538	03.1991 → 09.1996	OM 402.973	D 338
3235	07.1988 → 08.1994	OM 442.976	D 391	3538	03.1991 → 09.1996	OM 402.987	D 338
3235	10.1988 → 07.1992	OM 442.944	D 390	3538	03.1991 → 09.1996	OM 440.987	D 424
3235	10.1988 → 07.1992	OM 442.959	D 390	3538	09.1991 → 09.1996	OM 402.971	D 338
3235	10.1988 → 07.1992	OM 442.963	D 391	3538	09.1991 → 09.1996	OM 402.972	D 338
3235	10.1988 → 07.1992	OM 442.976	D 391	3538	09.1991 → 09.1996	OM 402.973	D 338
3235 K	07.1987 → 03.1991	OM 442.950	D 390	3538	09.1991 → 09.1996	OM 402.974	D 338
3235 K	07.1987 → 03.1991	OM 442.952	D 390	3538	09.1991 → 09.1996	OM 402.975	D 338
3235 K	09.1987 → 07.1992	OM 442.959	D 390	3538	09.1991 → 09.1996	OM 402.977	D 338
3235 L	07.1988 → 08.1994	OM 442.944	D 390	3538	09.1991 → 09.1996	OM 402.978	D 338
3235 L	07.1988 → 08.1994	OM 442.963	D 391	3538	09.1991 → 09.1996	OM 402.982	D 338
3235 L	07.1988 → 08.1994	OM 442.976	D 391	3538	09.1991 → 09.1996	OM 402.983	D 338
3236 A	07.1987 → 09.1996	OM 423.909	D 382	3538	09.1991 → 09.1996	OM 402.984	D 338
3238	10.1990 → 09.1996	OM 402.971	D 338	3538	09.1991 → 09.1996	OM 402.985	D 338
3238	10.1990 → 09.1996	OM 402.973	D 338	3538	09.1991 → 09.1996	OM 440.990	D 424
3238	10.1990 → 09.1996	OM 402.977	D 338	3538	03.1992 → 09.1996	OM 402.978	D 338
3238	10.1990 → 09.1996	OM 402.987	D 338	3538	01.1994 → 09.1996	OM 446.924	D 439
3238	03.1991 → 09.1996	OM 402.971	D 338	3538	01.1994 → 09.1996	OM 446.926	D 439
3238	03.1991 → 09.1996	OM 402.975	D 338	3538	01.1994 → 09.1996	OM 446.926	D 439
3238	03.1991 → 09.1996	OM 402.982	D 338	3538 AK	03.1991 → 09.1996	OM 402.973	D 338
3238	03.1991 → 09.1996	OM 402.985	D 338	3538 AK	03.1991 → 09.1996	OM 402.982	D 338
3238	03.1991 → 09.1996	OM 423.905	D 382	3538 AK	03.1991 → 09.1996	OM 402.983	D 338
3238	03.1991 → 09.1996	OM 423.907	D 382	3538 AK	03.1991 → 09.1996	OM 402.987	D 338
3238	01.1994 → 09.1996	OM 446.924	D 439	3538 AK	03.1992 → 09.1996	OM 402.978	D 338
3238 L	10.1990 → 09.1996	OM 402.972	D 338	3538 AK	01.1994 → 09.1996	OM 446.926	D 439
3238 L	12.1990 → 09.1996	OM 402.986	D 338	3538 AK	01.1994 → 09.1996	OM 446.930	D 439
3238 L	03.1991 → 09.1996	OM 402.985	D 338	3538 AK	01.1994 → 09.1996	OM 446.931	D 439
3238 L	01.1994 → 09.1996	OM 446.924	D 439	3538 K	03.1991 → 09.1996	OM 402.973	D 338
3238 L	01.1994 → 09.1996	OM 446.925	D 439	3538 K	03.1991 → 09.1996	OM 402.982	D 338
3238 L	01.1994 → 09.1996	OM 446.927	D 439	3538 K	03.1991 → 09.1996	OM 402.983	D 338

				Pos					Pos
3538 K	03.1991 → 09.1996	OM 402.987	D	<b>338</b>	LS 2624	01.1978 → 01.1995	OM 355.983	D	<b>367</b>
3538 K	03.1992 → 09.1996	OM 402.978	D	<b>338</b>	LS 2624	01.1978 → 01.1995	OM 355.984	D	<b>367</b>
3538 K	01.1994 → 09.1996	OM 446.926	D	<b>439</b>	LS 2628	11.1978 → 01.1995	OM 355.969	D	<b>366</b>
3538 K	01.1994 → 09.1996	OM 446.930	D	<b>439</b>	LS 911	01.1968 → 07.1995	OM 352.911	D	<b>129</b>
3544	01.1992 → 09.1996	OM 440.970	D	<b>412</b>	<b>T2/LN1 Cab with engine</b>				
3544	01.1992 → 09.1996	OM 440.978	D	<b>412</b>	809 DT (670.199)	04.1986 → 12.1994	OM 364.911	D	<b>209</b>
3544	01.1994 → 09.1996	OM 446.922	D	<b>439</b>	809 DT (670.199)	04.1986 → 12.1994	OM 364.911	D	<b>209</b>
3544 AK	03.1991 → 09.1996	OM 440.970	D	<b>412</b>	<b>TORINO</b>				
3544 AK	03.1991 → 09.1996	OM 440.980	D	<b>424</b>	OH	01.2009 →	OM 906.999	D	<b>239</b>
3544 AK	05.1992 → 09.1996	OM 440.985	D	<b>424</b>	OH	01.2009 →	OM 906.999	D	<b>239</b>
3544 K	03.1991 → 09.1996	OM 440.970	D	<b>412</b>	OH	01.2009 →	OM 924.925	D	<b>281</b>
3548	05.1992 → 09.1996	OM 440.975	D	<b>413</b>	<b>TOURINO (O 510)</b>				
3548	05.1992 → 09.1996	OM 442.993	D	<b>414</b>	TOURINO	10.2003 →	OM 906.961	D	<b>254</b>
3550	05.1992 → 09.1996	OM 440.975	D	<b>413</b>	TOURINO	10.2003 →	OM 906.962	D	<b>254</b>
3550	05.1992 → 09.1996	OM 440.976	D	<b>413</b>	TOURINO	10.2003 →	OM 926.939	D	<b>286</b>
3550	05.1992 → 09.1996	OM 442.993	D	<b>414</b>	<b>TOURISMO (O 350)</b>				
3550	05.1992 → 09.1996	OM 442.997	D	<b>412</b>	15	08.1998 →	OM 457.941	D	<b>454</b>
3550 K	03.1991 → 09.1996	OM 440.975	D	<b>413</b>	15	08.1998 →	OM 457.952	D	<b>449</b>
3550 K	03.1991 → 09.1996	OM 442.997	D	<b>412</b>	15	08.1998 →	OM 457.965	D	<b>449</b>
3550 K	07.1992 → 09.1996	OM 440.982	D	<b>412</b>	15	08.1998 →	OM 457.974	D	<b>457</b>
3550 S, 3553 S	05.1992 → 07.1992	OM 442.993	D	<b>414</b>	16	08.1998 →	OM 457.952	D	<b>449</b>
3550 S, 3553 S	05.1992 → 09.1996	OM 440.975	D	<b>413</b>	16	08.1998 →	OM 457.953	D	<b>449</b>
3550 S, 3553 S	05.1992 → 09.1996	OM 442.997	D	<b>412</b>	16	08.1998 →	OM 457.961	D	<b>449</b>
3553 S	01.1994 → 09.1996	OM 446.933	D	<b>372</b>	16	08.1998 →	OM 457.965	D	<b>449</b>
3553, 3553 L	01.1994 → 09.1996	OM 446.920	D	<b>439</b>	16	08.1998 →	OM 457.974	D	<b>457</b>
4050 A	07.1987 → 09.1996	OM 423.950	D	<b>387</b>	16	08.1998 →	OM 457.976	D	<b>457</b>
4050 A	03.1991 → 09.1996	OM 440.975	D	<b>413</b>	16	10.1999 →	OM 457.944	D	<b>454</b>
4844	12.1991 → 08.1994	OM 440.970	D	<b>412</b>	17	08.1998 →	OM 457.953	D	<b>449</b>
4844	03.1992 → 08.1994	OM 440.979	D	<b>412</b>	17	08.1998 →	OM 457.961	D	<b>449</b>
4844 K	03.1991 → 09.1996	OM 440.984	D	<b>424</b>	17	08.1998 →	OM 457.976	D	<b>457</b>
4844 K	01.1994 → 09.1996	OM 446.940	D	<b>436</b>	17	10.1999 →	OM 457.944	D	<b>454</b>
4850 A	07.1987 → 09.1996	OM 423.950	D	<b>387</b>	350	10.1995 →	OM 401.970	D	<b>336</b>
<b>T2/L</b>					350	10.1995 →	OM 402.970	D	<b>338</b>
L 2624	01.1959 → 01.1995	OM 355.976	D	<b>359</b>	350	10.1995 →	OM 441.980	D	<b>428</b>
L 2624	01.1959 → 01.1995	OM 355.982	D	<b>359</b>	350	10.1995 →	OM 445.934	D	<b>372</b>
L 2624	01.1978 → 01.1995	OM 355.983	D	<b>367</b>	350	10.1995 →	OM 446.938	D	<b>439</b>
L 2628	11.1978 → 01.1995	OM 355.969	D	<b>366</b>	350	10.1999 →	OM 457.944	D	<b>454</b>
L 911	01.1968 → 07.1995	OM 352.911	D	<b>129</b>	530	10.1999 →	OM 457.944	D	<b>454</b>
L 911	01.1972 → 07.1983	OM 353.911	D	<b>141</b>	Tourismo	08.1995 →	OM 402.970	D	<b>338</b>
LA 2624	01.1968 → 01.1995	OM 355.981	D	<b>359</b>	Tourismo	08.1995 →	OM 446.938	D	<b>439</b>
LA 2624	01.1968 → 01.1995	OM 355.982	D	<b>359</b>	Tourismo 15 RHD	01.2003 →	OM 457.941	D	<b>454</b>
LA 2624	09.1969 → 05.1977	OM 355.960	D	<b>359</b>	Tourismo 15 RHD	01.2003 →	OM 457.941	D	<b>454</b>
LA 2624	09.1969 → 05.1977	OM 355.963	D	<b>359</b>	Tourismo 15 RHD	01.2003 →	OM 457.941	D	<b>454</b>
LA 2624	09.1969 → 05.1977	OM 355.975	D	<b>359</b>	Tourismo 15 RHD	01.2003 →	OM 457.952	D	<b>449</b>
LA 2624	09.1969 → 05.1977	OM 355.976	D	<b>359</b>	Tourismo 15 RHD	01.2003 →	OM 457.952	D	<b>449</b>
LA 2624	01.1978 → 01.1995	OM 355.983	D	<b>367</b>	Tourismo 15 RHD	01.2003 →	OM 457.953	D	<b>449</b>
LA 911	01.1972 → 03.1977	OM 353.911	D	<b>141</b>	Tourismo 15 RHD	01.2003 →	OM 457.961	D	<b>449</b>
LA 911	01.1972 → 08.1983	OM 352.990	D	<b>130</b>	Tourismo 15 RHD	01.2003 →	OM 457.961	D	<b>449</b>
LA 911	01.1972 → 12.1995	OM 352.908	D	<b>130</b>	Tourismo 15 RHD	01.2003 →	OM 457.965	D	<b>449</b>
LAK 2624	01.1968 → 01.1995	OM 355.982	D	<b>359</b>	Tourismo 15 RHD	01.2003 →	OM 457.965	D	<b>449</b>
LAK 2624	09.1969 → 05.1977	OM 355.963	D	<b>359</b>	Tourismo 15 RHD	01.2003 →	OM 457.965	D	<b>449</b>
LAK 2624	09.1969 → 05.1977	OM 355.976	D	<b>359</b>	Tourismo 15 SHD	01.2003 →	OM 457.944	D	<b>454</b>
LAK 2624	01.1978 → 01.1995	OM 355.983	D	<b>367</b>	Tourismo 15 SHD	01.2003 →	OM 457.944	D	<b>454</b>
LAS 2624	01.1968 → 01.1995	OM 355.982	D	<b>359</b>	Tourismo 15 SHD	01.2003 →	OM 457.953	D	<b>449</b>
LAS 2624	09.1969 → 05.1977	OM 355.963	D	<b>359</b>	Tourismo 16 RHD	01.2003 →	OM 457.944	D	<b>454</b>
LAS 2624	09.1969 → 05.1977	OM 355.976	D	<b>359</b>	Tourismo 16 RHD	01.2003 →	OM 457.944	D	<b>454</b>
LAS 2624	01.1978 → 01.1995	OM 355.983	D	<b>367</b>	Tourismo 16 RHD	01.2003 →	OM 457.944	D	<b>454</b>
LK 2624	01.1968 → 01.1995	OM 355.981	D	<b>359</b>	Tourismo 16 RHD	01.2003 →	OM 457.952	D	<b>449</b>
LK 2624	09.1969 → 05.1977	OM 355.963	D	<b>359</b>	Tourismo 16 RHD	01.2003 →	OM 457.952	D	<b>449</b>
LK 2624	09.1969 → 05.1977	OM 355.975	D	<b>359</b>	Tourismo 16 RHD	01.2003 →	OM 457.953	D	<b>449</b>
LK 2624	09.1969 → 05.1977	OM 355.976	D	<b>359</b>	Tourismo 16 RHD	01.2003 →	OM 457.953	D	<b>449</b>
LK 2624	01.1978 → 01.1995	OM 355.983	D	<b>367</b>	Tourismo 16 RHD	01.2003 →	OM 457.953	D	<b>449</b>
LK 2624	01.1978 → 01.1995	OM 355.984	D	<b>367</b>	Tourismo 16 RHD	01.2003 →	OM 457.961	D	<b>449</b>
LK 2628	11.1978 → 01.1995	OM 355.969	D	<b>366</b>	Tourismo 16 RHD	01.2003 →	OM 457.961	D	<b>449</b>
LK 911	01.1968 → 07.1995	OM 352.911	D	<b>129</b>	Tourismo 16 RHD	01.2003 →	OM 457.961	D	<b>449</b>
LS 2624	01.1959 → 05.1977	OM 355.976	D	<b>359</b>	Tourismo 16 RHD	01.2003 →	OM 457.961	D	<b>449</b>
LS 2624	01.1968 → 01.1995	OM 355.981	D	<b>359</b>	Tourismo 16 RHD	01.2003 →	OM 457.965	D	<b>449</b>
LS 2624	09.1969 → 05.1977	OM 355.960	D	<b>359</b>	Tourismo 16 RHD	01.2003 →	OM 457.965	D	<b>449</b>
LS 2624	09.1969 → 05.1977	OM 355.975	D	<b>359</b>	Tourismo 16 RHD	01.2003 →	OM 542.966	D	<b>528</b>

M

				Pos					Pos
Tourismo 16 RHD	01.2003 →	OM 542.966	D	528	O 580-15 RHD	10.1999 →	OM 457.961	D	449
Tourismo 17 RHD	01.2003 →	OM 457.944	D	454	O 580-15 SHD	10.1999 →	OM 457.944	D	454
Tourismo 17 RHD	01.2003 →	OM 457.944	D	454	O 580-15 SHD	10.1999 →	OM 457.953	D	449
Tourismo 17 RHD	01.2003 →	OM 457.953	D	449	O 580-15 SHD	10.1999 →	OM 457.961	D	449
Tourismo 17 RHD	01.2003 →	OM 457.953	D	449	O 580-16 RHD	10.1999 →	OM 457.961	D	449
Tourismo 17 RHD	01.2003 →	OM 457.961	D	449	O 580-16 RHD	10.1999 →	OM 542.948	D	519
Tourismo 17 RHD	01.2003 →	OM 457.961	D	449	O 580-16 RHD	10.1999 →	OM 542.966	D	528
Tourismo 17 RHD	01.2003 →	OM 457.961	D	449	O 580-16 RHD	01.2003 →	OM 457.944	D	454
Tourismo 17 RHD	01.2003 →	OM 542.948	D	519	O 580-16 RHD	01.2003 →	OM 457.953	D	449
Tourismo 17 RHD	01.2003 →	OM 542.948	D	519	O 580-16 RHD	01.2003 →	OM 457.961	D	449
Tourismo 17 RHD	01.2003 →	OM 542.948	D	519	O 580-16 RHD	01.2003 →	OM 542.966	D	528
Tourismo 17 RHD	01.2003 →	OM 542.966	D	528	O 580-16 RHD, O 580-17	10.1999 →	OM 457.944	D	454
Tourismo 17 RHD	01.2003 →	OM 542.966	D	528	RHD				
Tourismo RHD, SHD	08.1995 →	OM 441.980	D	428	O 580-17 RHD	10.1999 →	OM 457.944	D	454
Tourismo RHD, SHD	09.1995 →	OM 445.934	D	372	O 580-17 RHD	10.1999 →	OM 457.953	D	449
Tourismo RHD, SHD	09.2003 →	OM 457.944	D	454	O 580-17 RHD	10.1999 →	OM 457.961	D	449
Tourismo RHD, SHD	09.2003 →	OM 457.944	D	454	O 580-17 RHD	10.1999 →	OM 542.948	D	519
<b>TOURO (O 500)</b>					O 580-17 RHD	10.1999 →	OM 542.948	D	519
1830	09.2008 →	OM 926.926	D	282	O 580-17 RHD	10.1999 →	OM 542.966	D	528
1830	09.2008 →	OM 926.930	D	289	O 580-17 SHD	10.1999 →	OM 542.948	D	519
1830	09.2008 →	OM 926.932	D	291	O 580-17 SHD	10.1999 →	OM 542.966	D	528
2436	01.2010 →	OM 457.915	D	461	RHD	08.1998 →	OM 457.961	D	449
2436	01.2010 →	OM 457.916	D	461	RHD	08.1998 →	OM 457.976	D	457
2436	01.2010 →	OM 457.925	D	440	<b>UNIMOG</b>				
2436	01.2010 →	OM 457.926	D	442	U 100, U 110, U 1100L	01.1977 → 12.1982	OM 353.980	D	130
2436	01.2010 →	OM 457.929	D	443	U 100, U 110, U 1100L	01.1977 → 05.1988	OM 353.901	D	130
2436	01.2010 →	OM 457.932	D	462	U 100, U 110, U 1100L	01.1977 → 05.1988	OM 353.940	D	130
O 500 GL, GLE	01.2001 →	OM 457.915	D	461	U 1000	01.1977 → 05.1988	OM 353.962	D	130
O 500 M	01.1996 →	OM 926.976	D	284	U 1000	01.1988 → 12.1992	OM 366.915	D	208
O 500 M	01.1996 →	OM 926.996	D	285	U 1000	01.1988 →	OM 352.900-016	D	135
O 500 M	01.2001 →	OM 906.918	D	241	U 1000	09.1991 → 12.1992	OM 356.914	D	208
O 500 M	01.2001 →	OM 906.933	D	241	U 100L	11.1992 →	OM 602.948	D	82
O 500 M	01.2001 →	OM 906.975	D	261	U 100L	07.1996 →	OM 602.981	D	85
O 500 M	01.2001 →	OM 906.983	D	259	U 100L	07.1996 →	OM 602.989	D	85
O 500 M	01.2001 →	OM 906.988	D	241	U 110, U 110L	02.1992 →	OM 364.958	D	212
O 500 R	01.2001 →	OM 926.910	D	288	U 110, U 110L	07.1992 →	OM 364.955	D	213
O 500 R	01.2001 →	OM 926.926	D	282	U 1150, U 1150L	05.1988 → 02.2001	OM 353.940	D	130
O 500 RSD	01.2001 →	OM 457.916	D	461	U 1150, U 1150L	05.1988 →	OM 353.940	D	130
O 500 RSD	01.2001 →	OM 457.927	D	461	U 1150L	05.1988 →	OM 353.907	D	161
O 500 RSD	01.2001 →	OM 457.932	D	462	U 1200	02.1982 → 12.1984	OM 353.973	D	130
O 500 U	01.2001 →	OM 906.918	D	241	U 1200	02.1982 → 05.1988	OM 353.995	D	168
O 500 U	01.2001 →	OM 906.988	D	241	U 1200	01.1988 → 02.2001	OM 366.949	D	190
O 500 U	01.2001 →	OM 926.926	D	282	U 1200	01.1988 →	OM 352.900-016	D	135
O 500 U	01.2001 →	OM 926.996	D	285	U 1200	09.1991 →	OM 356.954	D	190
Touro	10.2001 →	OM 457.944	D	454	U 1200	01.1992 →	OM 356.950	D	190
Touro	10.2001 →	OM 457.944	D	454	U 125, U 1100L	01.1977 → 01.1988	OM 353.907	D	161
Touro	2004 →	OM 460.952	D	466	U 1250	12.1984 → 12.1984	OM 353.973	D	130
<b>TRAVEGO (O 580)</b>					U 1250	12.1984 → 05.1988	OM 353.995	D	168
15	08.1998 →	OM 457.953	D	449	U 1250, U 1250L	01.1988 → 02.2001	OM 366.949	D	190
15	08.1998 →	OM 457.961	D	449	U 1250, U 1250L	01.1988 →	OM 352.900-016	D	135
15	10.1999 →	OM 457.944	D	454	U 1250, U 1250L	09.1991 →	OM 356.954	D	190
16	08.1998 →	OM 457.953	D	449	U 1250, U 1250L	01.1992 →	OM 356.950	D	190
16	08.1998 →	OM 457.961	D	449	U 1250L	05.1988 →	OM 366.955	D	190
16	08.1998 →	OM 542.966	D	528	U 130, U 140	07.1992 →	OM 364.982	D	213
17	08.1998 →	OM 457.953	D	449	U 130, U 140	05.1993 →	OM 364.985	D	213
17	08.1998 →	OM 457.961	D	449	U 1300	01.1977 → 12.1984	OM 353.973	D	130
17	08.1998 →	OM 542.966	D	528	U 1300	02.1982 → 12.1984	OM 353.995	D	168
O 580-15 RH	10.1999 →	OM 457.941	D	454	U 1300 L	01.1977 → 05.1988	OM 382.917	D	199
O 580-15 RH	10.1999 →	OM 542.948	D	519	U 1300, U 1300L	01.1977 → 12.1984	OM 353.973	D	130
O 580-15 RH	10.1999 →	OM 942.900	D	521	U 1300, U 1300L	01.1977 → 05.1988	OM 352.900-016	D	135
O 580-15 RH	10.1999 →	OM 942.911	D	521	U 1300, U 1300L	01.1977 → 05.1988	OM 353.961	D	130
O 580-15 RH/RHD	10.1999 → 02.2006	OM 457.938	D	437	U 1350L	05.1988 → 02.2001	OM 366.955	D	190
O 580-15 RH/RHD	10.1999 →	OM 457.936	D	437	U 1400	01.1988 → 04.2000	OM 366.947	D	190
O 580-15 RH/RHD	10.1999 →	OM 457.940	D	437	U 1400	01.1988 → 04.2000	OM 366.948	D	190
O 580-15 RH/RHD	10.1999 →	OM 457.944	D	454	U 1400	01.1988 → 04.2000	OM 366.955	D	190
O 580-15 RH/RHD	10.1999 →	OM 457.953	D	449	U 1400	01.1988 → 04.2000	OM 366.956	D	190
O 580-15 RH/RHD	10.1999 →	OM 457.961	D	449	U 1400	07.1994 → 04.2000	OM 357.912	D	197
O 580-15 RHD	10.1999 →	OM 457.944	D	454	U 140L	05.1993 →	OM 364.985	D	213
O 580-15 RHD	10.1999 →	OM 457.953	D	449	U 1450, U 1450L	01.1988 → 04.2000	OM 366.947	D	190



			Pos				Pos
U 1450,U 1450L	01.1988 → 04.2000	OM 366.948	D 190	U 2450L	07.1994 → 08.2002	OM 357.945	D 197
U 1450,U 1450L	01.1988 → 04.2000	OM 366.955	D 190	U 300	03.2000 →	OM 904.927	D 244
U 1450,U 1450L	01.1988 → 04.2000	OM 366.956	D 190	U 300	03.2000 →	OM 904.928	D 244
U 1450,U 1450L	07.1994 → 04.2000	OM 357.912	D 197	U 3000	09.2002 →	OM 900.920	D 249
U 1500	01.1977 → 05.1988	OM 352.900-016	D 135	U 3000	09.2002 →	OM 904.952	D 244
U 1500	01.1977 → 05.1988	OM 353.958	D 158	U 3000	09.2002 →	OM 904.953	D 244
U 1550	01.1986 → 05.1988	OM 353.958	D 158	U 318	05.2013 →	OM 934.971	D 317
U 1550 L	02.1986 → 05.1988	OM 353.961	D 130	U 40	01.1966 → 12.1971	OM 621.931	D 59
U 1550 L	02.1986 → 05.1988	OM 353.995	D 168	U 400	03.2000 →	OM 904.928	D 244
U 1550L	05.1988 →	OM 366.955	D 190	U 400	03.2000 →	OM 906.935	D 254
U 1550L	05.1988 →	OM 366.956	D 190	U 4000	09.2002 →	OM 900.920	D 249
U 1550L	09.1988 →	OM 366.984	D 190	U 4000	09.2002 →	OM 904.952	D 244
U 1550L	05.1991 → 04.2000	OM 356.980	D 190	U 4000	09.2002 →	OM 904.953	D 244
U 1550L	09.1991 →	OM 356.956	D 190	U 4000	09.2002 →	OM 924.916	D 290
U 1550L	01.1992 →	OM 356.955	D 190	U 4000	09.2002 →	OM 924.923	D 290
U 1550L	01.1992 →	OM 356.956	D 190	U 4023	05.2013 →	OM 934.974	D 317
U 1550L	01.1992 →	OM 356.997	D 190	U 423	05.2013 →	OM 934.972	D 317
U 1550L	01.1992 →	OM 366.963	D 190	U 423 L	05.2013 →	OM 934.972	D 317
U 1550L	07.1994 → 04.2000	OM 357.945	D 197	U 427, U 427 L	05.2013 →	OM 936.971	D 316
U 1550L	07.1994 →	OM 357.924	D 197	U 430, U 430 L	05.2013 →	OM 936.971	D 316
U 1600	01.1988 →	OM 366.949	D 190	U 45	01.1968 → 04.1971	OM 615.911	D 59
U 1600	09.1989 →	OM 366.984	D 190	U 500, UGN NA	10.2000 →	OM 906.935	D 254
U 1600	05.1991 → 02.2001	OM 356.980	D 190	U 500, UGN NA	10.2000 →	OM 906.955	D 254
U 1600	09.1991 →	OM 356.956	D 190	U 500, UGN NA	10.2000 →	OM 906.967	D 260
U 1600	01.1992 →	OM 356.997	D 190	U 5000	09.2002 →	OM 924.916	D 290
U 1600	07.1994 → 02.2001	OM 357.945	D 197	U 5000	09.2002 →	OM 924.923	D 290
U 1600	07.1994 →	OM 357.924	D 197	U 5000	11.2002 →	OM 906.935	D 254
U 1650,U 1650L	01.1988 →	OM 366.948	D 190	U 5000	01.2012 →	OM 924.923	D 290
U 1650,U 1650L	01.1988 →	OM 366.949	D 190	U 5023	05.2013 →	OM 934.974	D 317
U 1650,U 1650L	09.1989 →	OM 366.984	D 190	U 52, U 60, U 600,U 600L	01.1977 → 12.1976	OM 616.915	D 103
U 1650,U 1650L	05.1991 → 02.2001	OM 356.980	D 190	U 52, U 60, U 600,U 600L	01.1977 → 05.1988	OM 616.911	D 106
U 1650,U 1650L	09.1991 →	OM 356.956	D 190	U 52, U 60, U 600,U 600L	01.1977 → 05.1988	OM 616.931	D 103
U 1650,U 1650L	01.1992 →	OM 356.997	D 190	U 52, U 60, U 600,U 600L	01.1977 → 05.1988	OM 616.932	D 106
U 1650,U 1650L	07.1994 → 02.2001	OM 357.945	D 197	U 527, U 527 L	05.2013 →	OM 936.971	D 316
U 1650,U 1650L	07.1994 →	OM 357.924	D 197	U 530, U 530 L	05.2013 →	OM 936.971	D 316
U 1700, U 1700 L	09.1988 →	OM 366.963	D 190	U 54	04.1966 → 03.1972	OM 314.916	D 136
U 1700, U 1700 L	09.1988 →	OM 382.950	D 199	U 600	05.1988 → 02.2001	OM 616.942	D 106
U 1700, U 1700 L	01.1992 →	OM 356.957	D 190	U 600	05.1988 → 02.2001	OM 616.943	D 106
U 1700,U 1700L	05.1978 → 09.1988	OM 353.959	D 162	U 600	05.1988 →	OM 616.942	D 106
U 1700L	05.1978 → 09.1988	OM 353.959	D 162	U 600	05.1988 →	OM 616.943	D 106
U 1750,U 1750L	09.1988 → 02.2001	OM 366.963	D 190	U 65, U 70	01.1965 → 04.1966	OM 352.919	D 136
U 1750,U 1750L	09.1988 →	OM 366.963	D 190	U 650,U 650L	05.1988 → 02.2001	OM 616.942	D 106
U 1750,U 1750L	05.1991 →	OM 356.981	D 190	U 650,U 650L	05.1988 → 02.2001	OM 616.943	D 106
U 1750,U 1750L	05.1991 →	OM 356.981	D 190	U 650,U 650L	05.1988 →	OM 616.942	D 106
U 1750,U 1750L	01.1992 →	OM 356.957	D 190	U 650,U 650L	05.1988 →	OM 616.943	D 106
U 1750,U 1750L	01.1992 →	OM 356.957	D 190	U 66, U 72	03.1969 → 01.1988	OM 314.917	D 131
U 1800	04.1992 →	OM 356.998	D 190	U 72 ,U 80	01.1969 → 01.1977	OM 314.917	D 131
U 1850,U 1850L	04.1992 →	OM 356.998	D 190	U 80, U 84, U 90	05.1969 → 12.1976	OM 352.903	D 130
U 20	09.2006 →	OM 900.915	D 249	U 80, U 84, U 90	05.1969 → 01.1988	OM 353.902	D 130
U 20	09.2006 →	OM 900.915	D 249	U 800	01.1977 → 12.1988	OM 314.917	D 131
U 20	09.2006 →	OM 900.915	D 249	U 800	05.1988 → 12.1988	OM 314.917	D 131
U 2100	09.1989 →	OM 366.984	D 190	U 800L	01.1977 → 12.1988	OM 314.917	D 131
U 2100	01.1992 →	OM 356.997	D 190	U 90	11.1992 →	OM 602.941	D 82
U 2150	09.1989 →	OM 366.984	D 190	U 90	07.1996 →	OM 602.981	D 85
U 2150	01.1992 →	OM 356.997	D 190	U 90	07.1996 →	OM 602.989	D 85
U 2150,U 2150L	09.1989 →	OM 366.984	D 190	U 900	01.1977 → 01.1988	OM 353.940	D 130
U 2150,U 2150L	05.1991 →	OM 356.980	D 190	U 900	01.1977 → 02.2001	OM 353.902	D 130
U 2150,U 2150L	01.1992 →	OM 356.997	D 190	U 900	05.1988 →	OM 353.902	D 130
U 2150,U 2150L	07.1994 →	OM 357.924	D 197	U 900	11.1988 →	OM 356.912	D 208
U 2150,U 2150L	07.1994 →	OM 357.945	D 197	U 900	11.1988 →	OM 366.939	D 208
U 216	05.2013 →	OM 934.971	D 317	U S 404	1956 → 1965	M 180.952	B 9
U 218	05.2013 →	OM 934.971	D 317	U S 404	1956 → 1965	M 180.953	B 9
U 2400	05.1991 →	OM 356.980	D 190	U S 404	01.1968 → 12.1971	OM 615.911	D 59
U 2400	07.1994 →	OM 357.945	D 197	UX 100H,UX 100M	09.1996 →	OM 602.981	D 85
U 2400TG	07.1993 →	OM 356.980	D 190	UX 100H,UX 100M	09.1996 →	OM 602.989	D 85
U 2400TG	07.1994 →	OM 357.945	D 197	<b>UNIMOG 405 HEAVY</b>			
U 2450,U 2450L	05.1991 →	OM 356.980	D 190	U400	05.2013 →	OM 934.976	D 317
U 2450,U 2450L	07.1994 →	OM 357.945	D 197	U400	05.2013 →	OM 934.976	D 317
U 2450L	07.1993 →	OM 356.980	D 190	U400	05.2013 →	OM 934.978	D 317

M

		Pos			Pos		
U400	05.2013 →	OM 934.978 D	317	2641 B	04.2003 →	OM 541.944 D	514
U400	05.2013 →	OM 934.978 D	317	2641 B	04.2003 →	OM 541.974 D	532
U400	05.2013 →	OM 934.978 D	317	2641 B	04.2003 →	OM 541.990 D	536
<b>VARIO Cab with engine</b>				2643 B	04.2003 →	OM 541.925 D	514
613 D, 614 D (669.599, 669.899)	01.2006 →	OM 900.917 D	249	2643 B	04.2003 →	OM 541.946 D	514
615 D, 616 D (669.599, 669.899)	01.2006 →	OM 900.918 D	249	2644 B	04.2003 →	OM 541.946 D	514
618 D (669.599, 669.899)	09.2006 →	OM 900.919 D	249	2644 B	04.2003 →	OM 541.976 D	532
810 DT (670.398)	09.1996 → 12.2010	OM 904.904 D	242	2644 B	04.2003 →	OM 541.992 D	537
812 DT (670.398)	09.1996 → 12.2010	OM 904.961 D	244	2646 B	04.2003 →	OM 541.948 D	512
814 DT (670.398)	09.1996 →	OM 904.908 D	242	2646 B	04.2003 →	OM 541.980 D	534
816 DT (670.398)	09.1996 →	OM 904.923 D	242	2646 B	04.2003 →	OM 541.994 D	537
<b>ZETROS</b>				2648 B	04.2003 →	OM 541.948 D	512
1733 A	09.2008 →	OM 926.935 D	288	2648 B	04.2003 →	OM 541.978 D	532
1733 A	09.2008 →	OM 926.947 D	301	3231 B	04.2003 →	OM 541.920 D	523
1833 A	09.2008 →	OM 926.935 D	288	3231 B	04.2003 →	OM 541.940 D	514
1833 A	09.2008 →	OM 926.947 D	301	3232 B	10.2009 → 12.2008	OM 541.970 D	531
2633 A	09.2008 →	OM 926.935 D	288	3232 B	10.2009 → 12.2008	OM 541.996 D	530
2633 A	09.2008 →	OM 926.947 D	301	3235 B	04.2003 →	OM 541.922 D	514
2643 AS	05.2015 →	OM 457.970 D	472	3235 B	04.2003 →	OM 541.942 D	514
2733 A	09.2008 →	OM 926.935 D	288	3236 B	04.2003 →	OM 541.998 D	530
2733 A	09.2008 →	OM 926.947 D	301	3236 B	10.2009 →	OM 541.972 D	532
3343 AS	06.2017 →	OM 457.970 D	472	3240 B	04.2003 →	OM 541.923 D	514
<b>ACTROS</b>				3240 B	04.2003 →	OM 541.944 D	514
2631 B	04.1997 → 10.2002	OM 541.920 D	523	3241 B	10.2009 →	OM 541.974 D	532
2631 B	10.1997 → 10.2002	OM 541.940 D	514	3241 B	10.2009 →	OM 541.990 D	536
2635 B	04.1997 → 10.2002	OM 541.922 D	514	3243 B	04.2003 →	OM 541.925 D	514
2635 B	10.1997 → 10.2002	OM 541.942 D	514	3243 B	04.2003 →	OM 541.946 D	514
2640 B	04.1997 → 10.2002	OM 541.923 D	514	3244 B	10.2009 →	OM 541.976 D	532
2640 B	10.1997 → 10.2002	OM 541.944 D	514	3244 B	10.2009 →	OM 541.992 D	537
2643 B	04.1997 → 10.2002	OM 541.925 D	514	3246 B	04.2003 →	OM 541.948 D	512
2643 B	10.1997 → 10.2002	OM 541.946 D	514	3246 B	10.2009 →	OM 541.980 D	534
2646 B	10.1997 → 10.2002	OM 541.948 D	512	3246 B	10.2009 →	OM 541.994 D	537
3231 B	04.1997 → 10.2002	OM 541.920 D	523	3248 B	10.2009 → 12.2008	OM 541.978 D	532
3231 B	10.1997 → 10.2002	OM 541.940 D	514	3331 B	04.2003 →	OM 541.920 D	523
3235 B	04.1997 → 10.2002	OM 541.922 D	514	3331 B	04.2003 →	OM 541.940 D	514
3235 B	10.1997 → 10.2002	OM 541.942 D	514	3332 B	04.2003 →	OM 541.940 D	514
3240 B	04.1997 → 10.2002	OM 541.923 D	514	3332 B	04.2003 →	OM 541.970 D	531
3240 B	10.1997 → 10.2002	OM 541.944 D	514	3332 B	04.2003 →	OM 541.996 D	530
3243 B	04.1997 → 10.2002	OM 541.925 D	514	3335 B	04.2003 →	OM 541.922 D	514
3243 B	10.1997 → 10.2002	OM 541.946 D	514	3335 B	04.2003 →	OM 541.942 D	514
3246 B	10.1997 → 10.2002	OM 541.948 D	512	3336 B	04.2003 →	OM 541.942 D	514
3331 B	04.1997 → 10.2002	OM 541.920 D	523	3336 B	04.2003 →	OM 541.972 D	532
3331 B	10.1997 → 10.2002	OM 541.940 D	514	3336 B	04.2003 →	OM 541.998 D	530
3335 B	04.1997 → 10.2002	OM 541.922 D	514	3339 B	04.2003 →	OM 541.923 D	514
3335 B	10.1997 → 10.2002	OM 541.942 D	514	3339 B	04.2003 →	OM 541.944 D	514
3340 B	04.1997 → 10.2002	OM 541.923 D	514	3341 B	04.2003 → 12.2008	OM 541.944 D	514
3340 B	04.1997 → 10.2002	OM 541.923 D	514	3341 B	04.2003 → 12.2008	OM 541.990 D	536
3340 B	04.1997 → 10.2002	OM 541.944 D	514	3341 B	02.2005 → 12.2008	OM 541.974 D	532
3343 B	04.1997 → 10.2002	OM 541.925 D	514	3343 B	04.2003 →	OM 541.925 D	514
4140 B	04.1997 → 10.2002	OM 541.923 D	514	3343 B	04.2003 →	OM 541.946 D	514
4140 B	10.1997 → 10.2002	OM 541.944 D	514	3344 B	04.2003 →	OM 541.976 D	532
<b>ACTROS MP2 / MP3</b>				3344 B	04.2003 →	OM 541.992 D	537
2631 B	04.2003 →	OM 541.920 D	523	3346 B	04.2003 → 12.2008	OM 541.948 D	512
2631 B	04.2003 →	OM 541.940 D	514	3346 B	04.2003 → 12.2008	OM 541.994 D	537
2632 B	04.2003 →	OM 541.940 D	514	3346 B	02.2005 → 12.2008	OM 541.980 D	534
2632 B	04.2003 →	OM 541.970 D	531	3348 B	04.2003 → 12.2008	OM 541.948 D	512
2632 B	04.2003 →	OM 541.996 D	530	3348 B	02.2005 → 12.2008	OM 541.978 D	532
2635 B	04.2003 →	OM 541.922 D	514	4140 B	04.2003 →	OM 541.923 D	514
2635 B	04.2003 →	OM 541.942 D	514	4140 B	04.2003 →	OM 541.944 D	514
2636 B	04.2003 →	OM 541.942 D	514	4141 B	04.2003 →	OM 541.974 D	532
2636 B	04.2003 →	OM 541.972 D	532	4141 B	04.2003 →	OM 541.990 D	536
2636 B	04.2003 →	OM 541.998 D	530	4143 B	04.2003 →	OM 541.925 D	514
2640 B	04.2003 →	OM 541.923 D	514	4143 B	04.2003 →	OM 541.946 D	514
2640 B	04.2003 →	OM 541.944 D	514	4144 B	04.2003 →	OM 541.946 D	514
				4144 B	04.2003 →	OM 541.976 D	532
				4144 B	04.2003 →	OM 541.992 D	537
				4146 B	04.2003 → 12.2008	OM 541.948 D	512
				4146 B	04.2003 → 12.2008	OM 541.994 D	537
				4146 B	02.2005 → 12.2008	OM 541.980 D	534

M



				Pos					Pos
4148 B	02.2005 → 12.2008	OM 541.978	D	532	2651 LB	05.2013 →	OM 471.926	D	558
5041 B	06.2008 →	OM 541.923	D	514	2653 B	07.2015 →	OM 471.922	D	557
5041 B	06.2008 →	OM 541.944	D	514	2653 B	07.2015 →	OM 471.926	D	558
5041 B	06.2008 →	OM 541.974	D	532	2653 LB	07.2015 →	OM 471.922	D	557
5041 B	06.2008 →	OM 541.990	D	536	2653 LB	07.2015 →	OM 471.922	D	557
5044 B	06.2008 →	OM 541.946	D	514	2653 LB	07.2015 →	OM 471.926	D	558
5044 B	06.2008 →	OM 541.976	D	532	2653 LB	07.2015 →	OM 471.926	D	558
5044 B	06.2008 →	OM 541.992	D	537	3224 B	05.2013 →	OM 936.912	D	316
5046 B	06.2008 →	OM 541.948	D	512	3224 LB	05.2013 →	OM 936.912	D	316
5046 B	06.2008 →	OM 541.980	D	534	3227 B, 3227 LB	01.2013 →	OM 936.912	D	316
5046 B	06.2008 →	OM 541.994	D	537	3227 LB	01.2013 →	OM 936.912	D	316
<b>AGL (RoundNose)</b>					3230 B, 3230 LB	01.2013 →	OM 936.912	D	316
LB 2213	01.1972 → 12.1997	OM 352.912	D	129	3230 LB	01.2013 →	OM 936.912	D	316
LB 2216	01.1976 → 12.1987	OM 352.916	D	133	3232 B, 3232 LB	01.2013 →	OM 936.916	D	316
LB 2217	11.1985 → 11.1995	OM 353.909	D	133	3232 LB	01.2013 →	OM 936.916	D	316
LB 2219	01.1973 → 12.1980	OM 345.900	D	363	3233 B, 3233 LB	01.2013 →	OM 470.906	D	341
LB 2220	05.1987 → 05.1997	OM 345.973	D	368	3233 LB	01.2013 →	OM 470.906	D	341
LB 2318	05.1990 → 05.2000	OM 376.958	D	186	3235 B, 3235 LB	01.2013 →	OM 936.916	D	316
LB 2325	05.1990 → 05.2000	OM 489.961	D	417	3235 LB	01.2013 →	OM 936.916	D	316
<b>AROCS</b>					3236 B, 3236 LB	01.2013 →	OM 470.906	D	341
2624 B	05.2013 →	OM 936.912	D	316	3236 LB	01.2013 →	OM 470.906	D	341
2624 LB	05.2013 →	OM 936.912	D	316	3240 B, 3240 LB	01.2013 →	OM 470.906	D	341
2624 LB	05.2013 →	OM 936.912	D	316	3240 LB	01.2013 →	OM 470.906	D	341
2627 B, 2627 LB	01.2013 →	OM 936.912	D	316	3242 B, 3242 LB	01.2013 →	OM 471.900	D	556
2627 LB	05.2013 →	OM 936.912	D	316	3242 LB	01.2013 →	OM 471.900	D	556
2630 B, 2630 LB	01.2013 →	OM 936.912	D	316	3243 B, 3243 LB	01.2013 →	OM 470.906	D	341
2630 LB	05.2013 →	OM 936.912	D	316	3243 LB	01.2013 →	OM 470.906	D	341
2632 B, 2632 LB	01.2013 →	OM 936.916	D	316	3245 B, 3245 LB	01.2013 →	OM 471.900	D	556
2632 LB	05.2013 →	OM 936.916	D	316	3245 B, 3245 LB	01.2013 →	OM 471.926	D	558
2633 B, 2633 LB	01.2013 →	OM 470.906	D	341	3245 LB	01.2013 →	OM 471.900	D	556
2633 LB	05.2013 →	OM 470.906	D	341	3246 B	07.2015 →	OM 470.910	D	341
2633 LB	05.2013 →	OM 470.910	D	341	3246 B	07.2015 →	OM 470.913	D	341
2633 LB	05.2013 →	OM 470.913	D	341	3246 LB	07.2015 →	OM 470.910	D	341
2635 B, 2635 LB	01.2013 →	OM 936.916	D	316	3246 LB	07.2015 →	OM 470.913	D	341
2635 LB	05.2013 →	OM 936.916	D	316	3248 B, 3248 LB	01.2013 →	OM 471.900	D	556
2636 B, 2636 LB	01.2013 →	OM 470.906	D	341	3248 B, 3248 LB	01.2013 →	OM 471.926	D	558
2636 LB	05.2013 →	OM 470.906	D	341	3248 LB	01.2013 →	OM 471.906	D	556
2636 LB	05.2013 →	OM 470.910	D	341	3248 LB	01.2013 →	OM 471.926	D	558
2636 LB	05.2013 →	OM 470.913	D	341	3251 B, 3251 LB	01.2013 →	OM 471.909	D	556
2640 B, 2640 LB	01.2013 →	OM 470.906	D	341	3251 LB	01.2013 →	OM 471.909	D	556
2640 LB	05.2013 →	OM 470.906	D	341	3253 B	07.2015 →	OM 471.922	D	557
2640 LB	05.2013 →	OM 470.910	D	341	3253 B	07.2015 →	OM 471.926	D	558
2640 LB	05.2013 →	OM 470.913	D	341	3253 LB	07.2015 →	OM 471.922	D	557
2642 B, 2642 LB	01.2013 →	OM 471.900	D	556	3253 LB	07.2015 →	OM 471.926	D	558
2642 LB	05.2013 →	OM 471.900	D	556	3324 B	05.2013 →	OM 936.912	D	316
2642 LB	05.2013 →	OM 471.922	D	557	3327 B	05.2013 →	OM 936.912	D	316
2642 LB	05.2013 →	OM 471.926	D	558	3330 B	05.2013 →	OM 936.912	D	316
2643 B, 2643 LB	01.2013 →	OM 470.906	D	341	3332 B	05.2013 →	OM 936.916	D	316
2643 LB	05.2013 →	OM 470.906	D	341	3333 B, 3333 LB	01.2013 →	OM 470.906	D	341
2643 LB	05.2013 →	OM 470.910	D	341	3333 LB	05.2013 →	OM 470.906	D	341
2643 LB	05.2013 →	OM 470.913	D	341	3333 LB	05.2013 →	OM 470.910	D	341
2645 B, 2645 LB	01.2013 →	OM 471.900	D	556	3333 LB	05.2013 →	OM 470.913	D	341
2645 LB	05.2013 →	OM 471.900	D	556	3335 B	05.2013 →	OM 936.916	D	316
2645 LB	05.2013 →	OM 471.922	D	557	3336 B, 3336 LB	01.2013 →	OM 470.906	D	341
2645 LB	05.2013 →	OM 471.926	D	558	3336 LB	05.2013 →	OM 470.906	D	341
2646 B	07.2015 →	OM 470.910	D	341	3336 LB	05.2013 →	OM 470.910	D	341
2646 B	07.2015 →	OM 470.913	D	341	3336 LB	05.2013 →	OM 470.913	D	341
2646 LB	07.2015 →	OM 470.910	D	341	3340 B, 3340 LB	01.2013 →	OM 470.906	D	341
2646 LB	07.2015 →	OM 470.910	D	341	3340 LB	05.2013 →	OM 470.906	D	341
2646 LB	07.2015 →	OM 470.913	D	341	3340 LB	05.2013 →	OM 470.910	D	341
2646 LB	07.2015 →	OM 470.913	D	341	3340 LB	05.2013 →	OM 470.913	D	341
2648 B, 2648 LB	01.2013 →	OM 471.900	D	556	3342 B, 3342 LB	01.2013 →	OM 471.900	D	556
2648 B, 2648 LB	01.2013 →	OM 471.926	D	558	3342 LB	05.2013 →	OM 471.900	D	556
2648 LB	05.2013 →	OM 471.900	D	556	3342 LB	05.2013 →	OM 471.922	D	557
2648 LB	05.2013 →	OM 471.922	D	557	3342 LB	05.2013 →	OM 471.926	D	558
2648 LB	05.2013 →	OM 471.926	D	558	3343 B, 3343 LB	01.2013 →	OM 470.906	D	341
2651 B, 2651 LB	01.2013 →	OM 471.909	D	556	3343 LB	05.2013 →	OM 470.906	D	341
2651 LB	05.2013 →	OM 471.900	D	556	3343 LB	05.2013 →	OM 470.910	D	341
2651 LB	05.2013 →	OM 471.922	D	557	3343 LB	05.2013 →	OM 470.913	D	341

M

				Pos					Pos
3345 LB	05.2013 →	OM 471.900	D	556	815 F	01.1998 → 10.2004	OM 900.912	D	249
3345 LB	05.2013 →	OM 471.922	D	557	815 F	01.1998 → 10.2004	OM 904.922	D	244
3345 LB	05.2013 →	OM 471.926	D	558	917 AF	01.1998 → 10.2004	OM 904.911	D	242
3345B, 3345 LB	01.2013 →	OM 471.900	D	556	917 AF	01.1998 → 10.2004	OM 904.917	D	242
3346 B	07.2015 →	OM 470.910	D	341	917 AF	01.1998 → 10.2004	OM 904.949	D	244
3346 B	07.2015 →	OM 470.913	D	341	917 KO	01.1998 → 10.2004	OM 904.911	D	242
3346 LB	07.2015 →	OM 470.910	D	341	925 AF	01.1998 → 10.2004	OM 906.919	D	245
3346 LB	07.2015 →	OM 470.910	D	341	925 AF	01.1998 → 10.2004	OM 906.939	D	254
3346 LB	07.2015 →	OM 470.913	D	341	<b>ATEGO 2</b>				
3346 LB	07.2015 →	OM 470.913	D	341	1022 KO	10.2004 →	OM 924.922	D	290
3348 B, 3348 LB	01.2013 →	OM 471.900	D	556	1118 AF	01.2011 →	OM 900.913	D	249
3348 LB	05.2013 →	OM 471.900	D	556	1222 AF	10.2004 →	OM 924.922	D	290
3348 LB	05.2013 →	OM 471.922	D	557	1222 F	10.2004 →	OM 924.922	D	290
3348 LB	05.2013 →	OM 471.926	D	558	1226 AF	10.2004 →	OM 902.917	D	252
3351 B, 3351 LB	01.2013 →	OM 471.909	D	556	1226 F	10.2004 →	OM 902.917	D	252
3351 LB	05.2013 →	OM 471.900	D	556	1322 AF	10.2004 →	OM 924.922	D	290
3351 LB	05.2013 →	OM 471.922	D	557	1322 F	10.2004 →	OM 924.922	D	290
3351 LB	05.2013 →	OM 471.926	D	558	1322 LKO	10.2004 →	OM 924.922	D	290
3353 B	07.2015 →	OM 471.922	D	557	1324 LKO	10.2004 →	OM 902.916	D	251
3353 B	07.2015 →	OM 471.926	D	558	1326 AF	10.2004 →	OM 902.917	D	252
3353 LB	07.2015 →	OM 471.922	D	557	1326 F	10.2004 →	OM 902.917	D	252
3353 LB	07.2015 →	OM 471.922	D	557	1329 AF	10.2004 →	OM 902.918	D	252
3353 LB	07.2015 →	OM 471.926	D	558	1329 F	10.2004 →	OM 902.918	D	252
3353 LB	07.2015 →	OM 471.926	D	558	1522 AF	10.2004 →	OM 924.922	D	290
4133 B	01.2013 →	OM 470.906	D	341	1522 F	10.2004 →	OM 924.922	D	290
4136 B	01.2013 →	OM 470.906	D	341	1526 AF	10.2004 →	OM 902.917	D	252
4140 B	01.2013 →	OM 470.906	D	341	1529 AF	10.2004 →	OM 902.918	D	252
4142 B	01.2013 →	OM 471.900	D	556	1529 F	10.2004 →	OM 902.918	D	252
4143 B	01.2013 →	OM 470.906	D	341	815 F	10.2004 →	OM 904.916	D	242
4145 B	01.2013 →	OM 471.900	D	556	822 F	10.2004 →	OM 924.922	D	290
4146 B	07.2015 →	OM 470.910	D	341	918 AF	10.2004 →	OM 900.913	D	249
4146 B	07.2015 →	OM 470.913	D	341	922 AF	10.2004 →	OM 924.922	D	290
4148 B	01.2013 →	OM 471.900	D	556	926 AF	10.2004 →	OM 902.917	D	252
4151 B	01.2013 →	OM 471.909	D	556	<b>ATEGO 3</b>				
4153 B	07.2015 →	OM 471.922	D	557	1016 KO	05.2013 →	OM 934.911	D	317
4153 B	07.2015 →	OM 471.926	D	558	1018 KO	04.2013 →	OM 934.911	D	317
<b>ATEGO</b>					1021 KO	04.2013 →	OM 934.913	D	317
1017 KO, 1018 KO	01.1998 → 10.2004	OM 900.913	D	249	1023 KO	04.2013 →	OM 934.913	D	317
1017 KO, 1018 KO	01.1998 → 10.2004	OM 904.911	D	242	1221 AF	05.2013 →	OM 934.913	D	317
1017 KO, 1018 KO	01.1998 → 10.2004	OM 904.917	D	242	1221 F	05.2013 →	OM 934.913	D	317
1217 KO	01.1998 → 10.2004	OM 904.911	D	242	1223 AF	04.2013 →	OM 934.913	D	317
1225 AF	01.1998 → 10.2004	OM 906.919	D	245	1223 F	04.2013 →	OM 934.913	D	317
1225 AF	01.1998 → 10.2004	OM 906.939	D	254	1224 AF	05.2013 →	OM 936.910	D	316
1225 F	01.1998 → 10.2004	OM 906.919	D	245	1224 F	05.2013 →	OM 936.910	D	316
1225 F	01.1998 → 10.2004	OM 906.939	D	254	1227 AF	04.2013 →	OM 936.910	D	316
1317 KO, 1317 LKO, 1318 KO, 1318 LKO	01.1998 → 10.2004	OM 900.913	D	249	1227 F	04.2013 →	OM 936.910	D	316
1317 KO, 1317 LKO, 1318 KO, 1318 LKO	01.1998 → 10.2004	OM 904.911	D	242	1230 AF	04.2013 →	OM 936.910	D	316
1317 KO, 1317 LKO, 1318 KO, 1318 LKO	01.1998 → 10.2004	OM 904.917	D	242	1230 F	04.2013 →	OM 936.910	D	316
1323 KO, 1323 LKO	01.1998 → 10.2004	OM 906.910	D	253	1316 LKO	05.2013 →	OM 934.911	D	317
1323 KO, 1323 LKO	01.1998 → 10.2004	OM 906.915	D	245	1318 LKO	04.2013 →	OM 934.911	D	317
1325 AF	01.1998 → 10.2004	OM 906.919	D	245	1321 AF	05.2013 →	OM 934.913	D	317
1325 AF	01.1998 → 10.2004	OM 906.939	D	254	1321 F	05.2013 →	OM 934.913	D	317
1325 F	01.1998 → 10.2004	OM 906.919	D	245	1321 LKO	04.2013 →	OM 934.913	D	317
1325 F	01.1998 → 10.2004	OM 906.939	D	254	1323 AF	04.2013 →	OM 934.913	D	317
1328 AF	01.1998 → 10.2004	OM 906.911	D	252	1323 F	04.2013 →	OM 934.913	D	317
1328 AF	01.1998 → 10.2004	OM 906.916	D	245	1323 LKO	04.2013 →	OM 934.913	D	317
1328 F	01.1998 → 10.2004	OM 906.911	D	252	1324 AF	05.2013 →	OM 936.910	D	316
1328 F	01.1998 → 10.2004	OM 906.916	D	245	1324 F	05.2013 →	OM 936.910	D	316
1523 KO	01.1998 → 10.2004	OM 906.910	D	253	1324 LKO	04.2013 →	OM 936.910	D	316
1525 AF	01.1998 → 10.2004	OM 906.919	D	245	1327 AF	04.2013 →	OM 936.910	D	316
1525 AF	01.1998 → 10.2004	OM 906.939	D	254	1327 F	04.2013 →	OM 936.910	D	316
1528 AF	01.1998 → 10.2004	OM 906.911	D	252	1327 LKO	05.2013 →	OM 936.910	D	316
1528 AF	01.1998 → 10.2004	OM 906.916	D	245	1330 AF	04.2013 →	OM 936.910	D	316
1528 F	01.1998 → 10.2004	OM 906.911	D	252	1330 F	04.2013 →	OM 936.910	D	316
1528 F	01.1998 → 10.2004	OM 906.916	D	245	1330 LKO	05.2013 →	OM 936.910	D	316
2628 B	04.1998 → 10.2004	OM 906.921	D	245	1524 AF	05.2013 →	OM 936.910	D	316
					1524 F	05.2013 →	OM 936.910	D	316
					1527 AF	04.2013 →	OM 936.910	D	316
					1527 F	04.2013 →	OM 936.910	D	316

			Pos				Pos		
1530 AF	04.2013 →	OM 936.910	D	<b>316</b>	1823 L, 1823 LL	03.1998 → 03.2001	OM 906.940	D	<b>245</b>
1530 F	04.2013 →	OM 936.910	D	<b>316</b>	1823 L, 1823 LL	03.1998 → 09.2006	OM 906.951	D	<b>254</b>
916 AF	05.2013 →	OM 934.911	D	<b>317</b>	1823 L, 1823 LL	03.1998 →	OM 906.924	D	<b>241</b>
916 F	05.2013 →	OM 934.911	D	<b>317</b>	1824 L, 1824 LL	10.2006 →	OM 902.933	D	<b>252</b>
918 AF	04.2013 →	OM 934.911	D	<b>317</b>	1828 L	10.2000 →	M 906.900	G	<b>279</b>
918 F	04.2013 →	OM 934.911	D	<b>317</b>	1828 L, 1828 LL	03.1998 → 03.2001	OM 906.941	D	<b>247</b>
921 AF	05.2013 →	OM 934.913	D	<b>317</b>	1828 L, 1828 LL	03.1998 → 09.2006	OM 906.952	D	<b>254</b>
921 F	05.2013 →	OM 934.913	D	<b>317</b>	1828 L, 1828 LL	10.2006 →	M 902.900	G	<b>277</b>
923 AF	04.2013 →	OM 934.913	D	<b>317</b>	1828 L, 1828 LL	10.2006 →	M 902.903	G	<b>277</b>
923 F	04.2013 →	OM 934.913	D	<b>317</b>	1829 L, 1829 LL	10.2006 →	OM 902.927	D	<b>252</b>
924 AF	05.2013 →	OM 936.910	D	<b>316</b>	1833 L, 1833 LL	10.2006 →	OM 926.924	D	<b>291</b>
924 F	05.2013 →	OM 936.910	D	<b>316</b>	1833 L, 1833 LL	10.2006 →	OM 926.934	D	<b>292</b>
927 AF	04.2013 →	OM 936.910	D	<b>316</b>	2624 L	03.1998 →	OM 902.933	D	<b>252</b>
927 F	04.2013 →	OM 936.910	D	<b>316</b>	2628 L	10.2000 →	M 902.900	G	<b>277</b>
930 AF	05.2013 →	OM 936.910	D	<b>316</b>	2628 L	10.2000 →	M 902.903	G	<b>277</b>
930 F	05.2013 →	OM 936.910	D	<b>316</b>	2628 L	10.2001 →	M 906.900	G	<b>279</b>
<b>AXOR</b>					2628 LL	01.1998 →	OM 906.941	D	<b>247</b>
2628 B	01.2002 → 10.2004	OM 906.921	D	<b>245</b>	2628 LL	01.1998 →	OM 906.952	D	<b>254</b>
<b>AXOR 2</b>					2628 LL	03.1998 → 03.2001	OM 906.941	D	<b>247</b>
2628 B, 2629 B	10.2004 →	OM 902.915	D	<b>251</b>	2628 LL	03.1998 → 09.2006	OM 906.952	D	<b>254</b>
2628 B, 2629 B	10.2004 →	OM 906.921	D	<b>245</b>	2629 L, 2629 LL	10.2001 →	OM 902.927	D	<b>252</b>
2628 B, 2629 B	10.2004 →	OM 906.926	D	<b>245</b>	2629 L, 2629 LL	10.2001 →	OM 902.927	D	<b>252</b>
2633 B	10.2004 →	OM 926.913	D	<b>282</b>	2633 L	10.2001 →	OM 926.921	D	<b>291</b>
2633 B	10.2004 →	OM 926.919	D	<b>292</b>	2633 L	10.2001 →	OM 926.934	D	<b>292</b>
2633 B	10.2004 →	OM 926.945	D	<b>295</b>	2633 L, 2633 LL	10.2007 →	OM 926.924	D	<b>291</b>
2635 B	10.2005 →	OM 457.956	D	<b>454</b>	2633 L, 2633 LL	10.2007 →	OM 926.934	D	<b>292</b>
2635 B	10.2005 →	OM 457.957	D	<b>448</b>	3233 L, 3233 LL	10.2007 →	OM 926.934	D	<b>292</b>
2635 B	10.2005 →	OM 457.980	D	<b>470</b>	<b>HPN (LongNose)</b>				
2635 B	10.2005 →	OM 457.981	D	<b>450</b>	LB 2325	01.1996 →	OM 475.950	D	<b>401</b>
2636 B	10.2004 →	OM 457.937	D	<b>454</b>	<b>LK/LN2</b>				
2636 B	10.2004 →	OM 457.948	D	<b>448</b>	1120 AF	02.1987 → 12.1992	OM 366.994	D	<b>190</b>
2640 B	10.2004 →	OM 457.956	D	<b>454</b>	1120 AF	02.1987 → 02.1993	OM 366.992	D	<b>190</b>
2640 B	10.2004 →	OM 457.957	D	<b>448</b>	1120 AF	10.1992 → 12.1998	OM 356.994	D	<b>190</b>
2640 B	10.2005 →	OM 457.980	D	<b>470</b>	1120 AF	12.1992 → 12.1998	OM 356.995	D	<b>190</b>
2640 B	10.2005 →	OM 457.981	D	<b>450</b>	1120 F	02.1990 → 02.1993	OM 366.992	D	<b>190</b>
2643 B	10.2004 →	OM 457.956	D	<b>454</b>	1120 F	10.1992 → 12.1998	OM 356.996	D	<b>190</b>
2643 B	10.2004 →	OM 457.957	D	<b>448</b>	1124 AF	03.1992 → 08.1993	OM 356.983	D	<b>190</b>
2643 B	10.2005 →	OM 457.980	D	<b>470</b>	1124 AF	03.1992 → 08.1993	OM 356.989	D	<b>190</b>
2643 B	10.2005 →	OM 457.981	D	<b>450</b>	1124 AF	03.1992 → 08.1993	OM 356.991	D	<b>190</b>
2831 B	01.2012 →	OM 926.926	D	<b>282</b>	1124 AF	06.1994 → 12.1998	OM 357.943	D	<b>190</b>
2831 B	01.2012 →	OM 926.930	D	<b>289</b>	1124 AF	06.1994 → 12.1998	OM 357.944	D	<b>190</b>
2831 B	01.2012 →	OM 926.932	D	<b>291</b>	1124 F	03.1992 → 12.1998	OM 356.979	D	<b>190</b>
3028 B	01.2011 →	OM 906.921	D	<b>245</b>	1124 F	03.1992 → 12.1998	OM 356.983	D	<b>190</b>
3131 B	01.2011 →	OM 926.999	D	<b>285</b>	1124 F	06.1994 → 12.1998	OM 357.933	D	<b>190</b>
3236 B	10.2004 →	OM 457.956	D	<b>454</b>	1124 F	06.1994 → 12.1998	OM 357.942	D	<b>190</b>
3236 B	10.2004 →	OM 457.957	D	<b>448</b>	1314 KO	07.1984 → 02.1993	OM 366.936	D	<b>208</b>
3236 B	10.2005 →	OM 457.980	D	<b>470</b>	1314 KO	12.1992 → 12.1998	OM 356.908	D	<b>208</b>
3236 B	10.2005 →	OM 457.981	D	<b>450</b>	1317 KO	03.1994 → 12.1998	OM 357.903	D	<b>190</b>
3240 B	10.2004 →	OM 457.956	D	<b>454</b>	1317 KO	03.1994 → 12.1998	OM 357.962	D	<b>190</b>
3240 B	10.2004 →	OM 457.957	D	<b>448</b>	1317 KO	12.1994 → 12.1998	OM 356.944	D	<b>230</b>
3240 B	10.2005 →	OM 457.980	D	<b>470</b>	1317 KO	03.1996 → 12.1998	OM 904.907	D	<b>240</b>
3240 B	10.2005 →	OM 457.981	D	<b>450</b>	814 F	05.1986 → 02.1993	OM 366.905	D	<b>208</b>
3243 B	10.2004 →	OM 457.956	D	<b>454</b>	814 F	02.1992 → 12.1998	OM 356.905	D	<b>208</b>
3243 B	10.2004 →	OM 457.957	D	<b>448</b>	814 F	02.1992 → 12.1998	OM 356.911	D	<b>208</b>
3243 B	10.2005 →	OM 457.980	D	<b>470</b>	814 F	03.1994 → 12.1998	OM 354.922	D	<b>213</b>
3243 B	10.2005 →	OM 457.981	D	<b>450</b>	814 F	03.1996 → 12.1998	OM 904.906	D	<b>240</b>
3335 B	10.2004 → 10.2005	OM 457.956	D	<b>454</b>	817 F	03.1984 → 02.1993	OM 366.967	D	<b>195</b>
3335 B	10.2004 → 10.2005	OM 457.957	D	<b>448</b>	817 F	03.1984 → 02.1993	OM 366.973	D	<b>195</b>
3340 B	10.2004 → 10.2005	OM 457.956	D	<b>454</b>	817 F	12.1992 → 12.1998	OM 356.951	D	<b>190</b>
3340 B	10.2004 → 10.2005	OM 457.957	D	<b>448</b>	817 F	03.1994 → 12.1998	OM 357.908	D	<b>190</b>
3343 B	10.2004 →	OM 457.956	D	<b>454</b>	817 F	03.1996 → 12.1998	OM 904.907	D	<b>240</b>
3343 B	10.2004 →	OM 457.957	D	<b>448</b>	914 KO	01.1987 → 02.1993	OM 366.905	D	<b>208</b>
4135 B	10.2005 →	OM 457.956	D	<b>454</b>	914 KO	08.1989 → 08.1994	OM 366.940	D	<b>208</b>
4135 B	10.2005 →	OM 457.957	D	<b>448</b>	914 KO	02.1992 → 12.1998	OM 356.901	D	<b>208</b>
4140 B	01.2011 →	OM 457.956	D	<b>454</b>	914 KO	02.1992 → 12.1998	OM 356.911	D	<b>208</b>
4140 B	01.2011 →	OM 457.957	D	<b>448</b>	917 AF	02.1987 → 02.1993	OM 366.966	D	<b>195</b>
4143 B	01.2011 →	OM 457.956	D	<b>454</b>	917 AF	02.1987 → 02.1993	OM 366.974	D	<b>195</b>
4143 B	01.2011 →	OM 457.957	D	<b>448</b>	917 AF	02.1987 → 02.1993	OM 366.978	D	<b>195</b>
<b>ECONIC</b>					917 AF	12.1992 → 12.1998	OM 356.941	D	<b>190</b>

M



				Pos					Pos
917 AF	03.1994 → 12.1998	OM 357.909	D	190	1224 AF	02.1993 → 09.1996	OM 356.999	D	197
917 AF	03.1994 → 12.1998	OM 357.910	D	190	1224 AF	02.1993 → 09.1996	OM 366.999	D	190
917 KO	03.1994 → 12.1998	OM 357.901	D	190	1224 AF	02.1993 → 09.1996	OM 401.984	D	336
917 KO	03.1994 → 12.1998	OM 357.918	D	190	1224 AF	01.1994 → 09.1996	OM 357.946	D	197
917 KO	03.1996 → 12.1998	OM 904.907	D	240	1224 F	07.1989 → 08.1994	OM 356.999	D	197
<b>LP</b>					1226 AF	02.1990 → 09.1993	OM 442.907	D	504
LPKF 608	10.1969 → 10.1977	OM 314.910	D	131	1226 AF	02.1990 → 09.1993	OM 442.914	D	504
LPKF 608	10.1969 → 10.1977	OM 314.944	D	131	1226 AF	02.1990 → 09.1993	OM 442.920	D	504
LPKF 709	11.1977 → 12.1984	OM 314.910	D	131	1226 AF	02.1990 → 09.1993	OM 442.926	D	504
LPKF 709	11.1977 → 12.1984	OM 314.944	D	131	1226 AF	02.1990 → 09.1993	OM 442.932	D	504
LPKF 808, LPKF 809	10.1969 → 10.1977	OM 314.910	D	131	1226 AF	02.1990 → 09.1993	OM 442.933	D	504
LPKF 808, LPKF 809	10.1969 → 10.1977	OM 314.944	D	131	1226 AF	02.1993 → 09.1996	OM 401.973	D	336
LPKO 608	10.1969 → 07.1977	OM 314.910	D	131	1226 AF	02.1993 → 09.1996	OM 401.978	D	336
LPKO 608	10.1969 → 07.1977	OM 314.944	D	131	1226 AF	02.1993 → 09.1996	OM 401.984	D	336
LPKO 709	10.1969 → 07.1977	OM 314.910	D	131	1226 AF	02.1993 → 09.1996	OM 401.989	D	336
LPKO 709	10.1969 → 07.1977	OM 314.944	D	131	1227 AF, 1227 LAF	01.1992 → 07.1992	OM 445.933	D	372
<b>MB-TRAC</b>					1231 AF	01.1992 → 09.1996	OM 401.986	D	336
100	12.1980 → 08.1991	OM 615.963	D	59	1234 AF	01.1992 → 09.1996	OM 441.989	D	418
100	05.1986 → 06.1989	OM 615.970	D	59	1234 AF	01.1992 → 09.1996	OM 441.993	D	418
100	09.1987 → 12.1994	OM 616.963	D	102	1234 AF	01.1994 → 09.1996	OM 445.923	D	438
1000	12.1982 → 12.1987	OM 353.985	D	153	1422 F	07.1989 → 09.1993	OM 441.913	D	503
1000, 1100	02.1987 → 12.1991	OM 366.908	D	208	1422 F	07.1989 → 09.1993	OM 441.925	D	503
1000, 1100	02.1987 → 12.1991	OM 366.912	D	208	1422 F	03.1993 → 08.1994	OM 356.999	D	197
1100	03.1979 → 03.1987	OM 353.949	D	139	1427 F	02.1993 → 09.1996	OM 401.985	D	336
1100	03.1979 → 08.1987	OM 352.900-016	D	135	1427 F	02.1993 → 09.1996	OM 401.991	D	336
120	01.1987 → 12.1990	OM 616.963	D	102	1427 F	01.1994 → 09.1996	OM 445.936	D	372
130	12.1980 → 09.1983	OM 616.961	D	106	1429 AF	01.1992 → 08.1994	OM 442.926	D	504
1300	03.1976 → 08.1987	OM 352.900-016	D	135	1431 F	07.1988 → 08.1996	OM 401.979	D	336
1300	10.1976 → 03.1987	OM 353.957	D	160	1627 AF	01.1992 → 09.1993	OM 442.920	D	504
1300 Turbo, 1400 Turbo	02.1982 → 12.1991	OM 366.977	D	190	1627 AF	01.1992 → 09.1993	OM 442.933	D	504
1300 Turbo, 1400 Turbo	03.1987 → 12.1991	OM 366.958	D	190	1627 AF	01.1992 → 08.1994	OM 442.914	D	504
1300 turbo	01.1977 → 05.1988	OM 352.937	D	133	1627 AF	01.1992 → 08.1994	OM 442.932	D	504
1300 turbo	03.1987 → 12.1992	OM 366.977	D	190	2422 B	09.1989 → 08.1994	OM 441.912	D	503
140	10.1983 → 12.1986	OM 616.961	D	106	2422 B	09.1989 → 08.1994	OM 441.924	D	503
140	10.1983 → 06.1990	OM 616.963	D	102	2426 B	02.1990 → 08.1994	OM 442.921	D	504
150	12.1980 → 09.1983	OM 616.963	D	102	2427 B	02.1990 → 08.1994	OM 442.923	D	504
1500	07.1980 → 03.1987	OM 353.976	D	166	2427 B	07.1992 → 08.1994	OM 401.977	D	336
160	01.1987 → 06.1990	OM 616.963	D	102	2427 B	07.1992 → 08.1994	OM 401.978	D	336
1600 Turbo	06.1990 → 12.1991	OM 366.954	D	190	2527 B	03.1991 → 09.1996	OM 401.973	D	336
170	12.1980 → 09.1983	OM 616.961	D	106	2527 B	03.1991 → 09.1996	OM 401.980	D	336
180	10.1983 → 12.1986	OM 616.961	D	106	2527 B	07.1992 → 09.1996	OM 401.978	D	336
180	10.1983 → 12.1986	OM 616.963	D	102	2527 B	01.1994 → 09.1996	OM 445.927	D	372
1800	06.1990 → 12.1991	OM 366.954	D	190	2531 B	12.1987 → 09.1996	OM 401.979	D	336
65/70, 700, 800	07.1973 → 12.1975	OM 314.956	D	147	<b>NG</b>				
65/70, 700, 800	07.1973 → 12.1991	OM 314.957	D	147	1013 KO	02.1976 → 12.1984	OM 353.943	D	130
65/70, 700, 800	07.1973 → 12.1991	OM 394.900-006	D	148	1013 KO	02.1976 → 12.1984	OM 353.945	D	130
		(AFS)			1013 KO	02.1976 → 12.1984	OM 353.946	D	130
65/70, 700, 800	07.1973 → 12.1991	OM 394.900-007	D	148	1017 AF	11.1975 → 09.1985	OM 353.954	D	155
		(AFS)			1017 KO,1017 F	11.1975 → 09.1985	OM 353.952	D	141
700, 800	02.1987 → 12.1991	OM 364.908	D	222	1017 KO,1017 F	11.1975 → 09.1985	OM 353.953	D	141
700, 800	02.1987 → 12.1991	OM 364.909	D	222	1017 KO,1017 F	11.1975 → 09.1985	OM 353.954	D	155
800 turbo	06.1985 →	OM 380.940	D	216	1213 AKO	09.1975 → 05.1986	OM 353.944	D	130
800 turbo	06.1985 →	OM 380.942	D	216	1213 AKO	02.1976 → 12.1984	OM 353.946	D	130
800 turbo	12.1993 →	OM 380.943	D	212	1213 KO	09.1975 → 05.1986	OM 353.944	D	130
90	03.1985 → 12.1986	OM 615.963	D	59	1213 KO	02.1976 → 12.1984	OM 353.946	D	130
90	05.1986 → 12.1986	OM 615.970	D	59	1217 KO	09.1975 → 07.1985	OM 353.951	D	141
900		OM 394.900-009	D	148	1217 KO	09.1975 → 09.1985	OM 353.950	D	141
		(AFS)			1217 KO	09.1975 → 09.1985	OM 353.953	D	141
900	09.1981 → 12.1982	OM 314.970	D	167	1219 AF	09.1975 → 12.1982	OM 401.919	D	325
900	03.1987 → 12.1991	OM 364.951	D	223	1219 F	09.1975 → 09.1984	OM 401.918	D	325
Forst-Trac	04.1991 →	OM 364.959	D	213	1222 AF	05.1982 → 12.1991	OM 421.906	D	369
<b>MK</b>					1222 F	05.1982 → 12.1991	OM 421.906	D	369
1222 AF	09.1989 → 09.1993	OM 441.915	D	503	1225 AF	05.1982 → 12.1991	OM 422.913	D	370
1222 AF	09.1989 → 09.1993	OM 441.917	D	503	1225 AF	05.1982 → 12.1991	OM 422.923	D	370
1222 AF	09.1989 → 09.1993	OM 441.923	D	503	1225 AF	07.1988 → 12.1991	OM 442.907	D	504
1222 F	07.1989 → 09.1993	OM 441.913	D	503	1228 AF	05.1982 → 03.1991	OM 422.913	D	370
1222 F	07.1989 → 07.1994	OM 441.925	D	503	1413 AKO	09.1975 → 12.1984	OM 353.944	D	130
1222 F	07.1989 → 08.1994	OM 441.905	D	503	1413 AKO	02.1976 → 12.1984	OM 353.946	D	130
1222 F	07.1989 → 08.1994	OM 441.923	D	503	1413 AKO	02.1977 → 12.1984	OM 353.964	D	130

				Pos					Pos
1413 KO	09.1975 → 12.1984	OM 353.944	D	130	3229 B	09.1989 → 07.1992	OM 442.928	D	504
1413 KO	02.1976 → 12.1984	OM 353.946	D	130	3233 B	10.1990 → 07.1992	OM 441.982	D	404
1413 KO	02.1977 → 12.1984	OM 353.964	D	130	3233 B	10.1990 → 07.1992	OM 441.985	D	404
1417 AKO	05.1975 → 12.1984	OM 353.953	D	141	3234 B	02.1992 → 09.1996	OM 441.988	D	418
1417 KO	05.1975 → 12.1984	OM 353.951	D	141	3234 B	02.1992 → 09.1996	OM 441.990	D	418
1417 KO	02.1977 → 12.1984	OM 353.971	D	141	3234 B	02.1992 → 09.1996	OM 441.992	D	418
1419 F	05.1975 → 12.1982	OM 401.914	D	325	3234 B	01.1994 → 09.1996	OM 445.922	D	372
1419 F	05.1975 → 12.1982	OM 401.919	D	325	3535 B	10.1988 → 08.1994	OM 442.945	D	390
1422 F	05.1982 → 10.1990	OM 421.906	D	369	3535 B	10.1988 → 08.1994	OM 442.959	D	390
1424 F	07.1975 → 01.1987	OM 402.919	D	327	3535 B	10.1988 → 08.1994	OM 442.989	D	391
1425 AF	05.1980 → 03.1993	OM 422.909	D	370	<b>T2/L</b>				
1428 AF	02.1980 → 03.1991	OM 422.913	D	370	LAB 2624	09.1969 → 05.1977	OM 355.963	D	359
1428 F	05.1982 → 12.1991	OM 422.907	D	370	LAB 2624	09.1969 → 05.1977	OM 355.976	D	359
1428 F	05.1982 → 12.1991	OM 422.913	D	370	LAB 2624	01.1978 → 01.1995	OM 355.983	D	367
1429 AF	07.1988 → 08.1994	OM 442.907	D	504	LB 2624	09.1969 → 05.1977	OM 355.960	D	359
1613 KO	09.1975 → 12.1984	OM 353.944	D	130	LB 2624	09.1969 → 05.1977	OM 355.975	D	359
1613 KO	02.1976 → 12.1984	OM 353.946	D	130	LB 2624	09.1969 → 05.1977	OM 355.976	D	359
1617 KO	01.1975 → 07.1985	OM 353.951	D	141	LB 2624	01.1978 → 01.1995	OM 355.983	D	367
1617 KO	01.1975 → 07.1985	OM 353.953	D	141	LKO 911	01.1968 → 07.1995	OM 352.911	D	129
1619 KO	11.1974 → 01.1987	OM 401.914	D	325	<b>T2/L Municipal Vehicle</b>				
1619 KO	05.1975 → 12.1984	OM 401.905	D	325	LF 408 G (309.050,	08.1972 → 12.1974	M 115.927	B	58
2219 KO	06.1976 → 01.1987	OM 401.914	D	325	309.051, 309.052,				
2219 KO	06.1976 → 01.1987	OM 401.926	D	325	309.053, 309.054,...				
2222 B	05.1982 → 03.1991	OM 421.905	D	382	LF 408 G (309.050,	08.1972 → 12.1974	M 115.929	B	58
2222 B	05.1982 → 03.1991	OM 421.907	D	384	309.051, 309.052,				
2224 B	05.1975 → 03.1984	OM 402.914	D	327	309.053, 309.054,...				
2225 B	08.1983 → 03.1991	OM 422.912	D	370	LF 409 G (309.050,	01.1975 → 08.1982	M 115.952	B	117
2626 AB	05.1974 → 12.1980	OM 402.906	D	331	309.051, 309.052,				
2626 AB	05.1974 → 12.1980	OM 402.912	D	327	309.053, 309.054,...				
2626 AB	05.1974 → 12.1980	OM 402.926	D	327	LF 409 G (309.050,	01.1975 → 08.1982	M 115.970	B	117
2626 B	05.1974 → 12.1980	OM 402.906	D	331	309.051, 309.052,				
2626 B	05.1974 → 12.1980	OM 402.912	D	327	309.053, 309.054,...				
2626 B	05.1974 → 12.1980	OM 402.926	D	327	LF 409 G (309.050,	01.1975 → 08.1982	M 115.971	B	117
2628 B	02.1980 → 05.1989	OM 422.911	D	370	309.051, 309.052,				
2628 B	02.1980 → 08.1989	OM 422.905	D	370	309.053, 309.054,...				
3025 B	08.1983 → 03.1991	OM 422.909	D	370	LKO 508 DG (309.430,	06.1972 → 02.1977	OM 314.946	D	131
3025 B	08.1983 → 03.1991	OM 422.912	D	370	309.431, 309.432,				
3025 B	12.1985 → 07.1987	OM 422.919	D	370	309.433, 309.435)				
3025 B	12.1985 → 07.1987	OM 422.920	D	370	LKO 508 DG (309.430,	06.1972 → 02.1977	OM 314.948	D	131
3025 B	12.1985 → 07.1987	OM 422.920	D	370	309.431, 309.432,				
3028 B	12.1985 → 07.1987	OM 422.919	D	370	309.433, 309.435)				
3228 B	07.1987 → 07.1987	OM 422.919	D	370	<b>UNIMOG</b>				
3228 B	07.1987 → 03.1991	OM 422.921	D	370	120	01.1976 → 12.1976	OM 352.904	D	129
3250 AF	09.1985 → 08.1994	OM 423.950	D	387	120	01.1976 → 12.1976	OM 352.908	D	130
3328 B	02.1980 → 05.1989	OM 422.911	D	370	120	01.1976 → 12.1976	OM 352.953	D	129
3328 B	02.1980 → 03.1991	OM 422.905	D	370	120	01.1976 → 12.1976	OM 352.955	D	129
3328 B	02.1980 → 03.1991	OM 422.907	D	370	120	01.1976 → 12.1976	OM 352.987	D	129
3328 B	02.1980 → 03.1991	OM 422.913	D	370	120	01.1976 → 12.1976	OM 352.991	D	129
3328 B	02.1980 → 03.1991	OM 422.916	D	370	120	01.1976 → 12.1976	OM 353.960	D	130
3328 B	07.1982 → 07.1987	OM 422.914	D	370	120	07.1976 → 12.1976	OM 353.973	D	130
3328 B	07.1982 → 07.1987	OM 422.919	D	370	150	02.1976 → 12.1976	OM 353.958	D	158
3333 B	12.1982 → 03.1991	OM 422.954	D	381	1800	04.1992 →	OM 356.997	D	190
3336 B	12.1982 → 03.1991	OM 423.907	D	382	1800	04.1992 →	OM 356.998	D	190
3528 B	07.1987 → 07.1987	OM 422.919	D	370	1800	04.1992 →	OM 357.924	D	197
<b>SK</b>					20		OM 900.915	D	249
2055 AF	01.1992 → 09.1996	OM 442.997	D	412	30	01.1949 →	OM 636.915	D	3
2629 B	07.1988 → 08.1994	OM 442.906	D	504	30	01.1949 →	OM 636.916	D	5
2629 B	07.1988 → 08.1994	OM 442.907	D	504	30	01.1949 →	OM 636.918	D	5
2629 B	07.1988 → 08.1994	OM 442.917	D	504	30	01.1949 →	OM 636.931	D	5
2629 B	07.1988 → 08.1994	OM 442.925	D	504	34	01.1949 → 09.1975	OM 636.915	D	3
2629 B	07.1988 → 08.1994	OM 442.926	D	504	34	01.1949 → 09.1975	OM 636.916	D	5
2629 B	07.1988 → 08.1994	OM 442.929	D	504	34	01.1949 → 09.1975	OM 636.918	D	5
2631 B	06.1992 → 09.1996	OM 401.972	D	336	34	01.1949 → 09.1975	OM 636.931	D	5
2631 B	06.1992 → 09.1996	OM 401.979	D	336	34	01.1965 → 09.1975	OM 636.914	D	5
2631 B	06.1992 → 09.1996	OM 401.981	D	336	406		OM 341.934	D	142
2631 B	06.1992 → 09.1996	OM 401.987	D	336	411	01.1949 →	OM 636.915	D	3
2631 B	06.1992 → 09.1996	OM 401.993	D	336	411	01.1949 →	OM 636.916	D	5
3229 B	09.1989 → 07.1992	OM 442.915	D	504	411	01.1949 →	OM 636.918	D	5
3229 B	09.1989 → 07.1992	OM 442.916	D	504	411	01.1949 →	OM 636.931	D	5
3229 B	09.1989 → 07.1992	OM 442.927	D	504	416	05.1966 → 04.1969	OM 352.984	D	130

M



			Pos				Pos
416	05.1969 → 12.1976	OM 353.901	D	<b>130</b>			
416	10.1969 → 12.1985	OM 353.905	D	<b>130</b>			
421		OM 615.935	D	<b>59</b>			
421		OM 616	D	<b>102</b>			
421		OM 616.910	D	<b>106</b>			
421		OM 616.911	D	<b>106</b>			
421		OM 616.912	D	<b>102</b>			
421		OM 616.916	D	<b>106</b>			
421		OM 616.919	D	<b>102</b>			
425	02.1976 → 12.1976	OM 353.958	D	<b>158</b>			
425	07.1976 → 12.1976	OM 353.973	D	<b>130</b>			
426		OM 341.918	D	<b>138</b>			
435	01.1971 →	OM 353.977	D	<b>141</b>			
55	01.1966 → 12.1967	OM 621.916	D	<b>59</b>			
55	01.1966 → 12.1967	OM 621.931	D	<b>59</b>			
55	01.1968 → 12.1971	OM 615.914	D	<b>59</b>			
90	05.1969 → 12.1976	OM 341.918	D	<b>138</b>			
90	05.1969 → 12.1976	OM 341.938	D	<b>137</b>			
90	05.1969 → 12.1976	OM 352.903	D	<b>130</b>			
90	05.1969 → 12.1976	OM 352.904	D	<b>129</b>			
90	05.1969 → 12.1976	OM 352.908	D	<b>130</b>			
90	05.1969 → 12.1976	OM 352.953	D	<b>129</b>			
90	05.1969 → 12.1976	OM 352.955	D	<b>129</b>			
90	05.1969 → 12.1976	OM 352.987	D	<b>129</b>			
90	05.1969 → 12.1976	OM 352.991	D	<b>129</b>			
90	05.1969 → 12.1976	OM 353.901	D	<b>130</b>			
90	05.1969 → 12.1976	OM 353.902	D	<b>130</b>			
90	11.1992 → 12.1976	OM 602.941	D	<b>82</b>			
95	10.1976 → 12.1976	OM 352.904	D	<b>129</b>			
95	10.1976 → 12.1976	OM 352.908	D	<b>130</b>			
95	10.1976 → 12.1976	OM 352.953	D	<b>129</b>			
95	10.1976 → 12.1976	OM 352.955	D	<b>129</b>			
95	10.1976 → 12.1976	OM 352.987	D	<b>129</b>			
95	10.1976 → 12.1976	OM 352.991	D	<b>129</b>			
95	10.1976 → 12.1976	OM 353.962	D	<b>130</b>			
U 100, U 110T, U 1100T	01.1977 → 12.1982	OM 353.980	D	<b>130</b>			
U 100, U 110T, U 1100T	01.1977 → 02.2001	OM 353.901	D	<b>130</b>			
U 100, U 110T, U 1100T	01.1977 → 02.2001	OM 353.940	D	<b>130</b>			
U 1000T	01.1977 → 12.1982	OM 353.940	D	<b>130</b>			
U 1000T	01.1977 → 12.1982	OM 353.980	D	<b>130</b>			
U 1200T	01.1983 → 12.1984	OM 353.973	D	<b>130</b>			
U 1200T	01.1983 → 05.1988	OM 353.995	D	<b>168</b>			
U 1200T	01.1988 →	OM 366.949	D	<b>190</b>			
U 1200T	09.1991 →	OM 356.954	D	<b>190</b>			
U 140T	07.1992 →	OM 364.982	D	<b>213</b>			
U 1500T	01.1977 → 05.1988	OM 353.958	D	<b>158</b>			
U 1700T	09.1988 → 02.2001	OM 366.963	D	<b>190</b>			
U 1700T	09.1988 →	OM 352.900-016	D	<b>135</b>			
U 1700T	01.1992 →	OM 356.957	D	<b>190</b>			
U 1800T	04.1992 →	OM 356.998	D	<b>190</b>			
U 2100T	09.1989 →	OM 366.984	D	<b>190</b>			
U 2100T	01.1992 →	OM 356.997	D	<b>190</b>			
U 60T, U 600T	01.1977 → 12.1976	OM 616.915	D	<b>103</b>			
U 60T, U 600T	01.1977 → 05.1988	OM 616.911	D	<b>106</b>			
U 60T, U 600T	01.1977 → 05.1988	OM 616.931	D	<b>103</b>			
U 60T, U 600T	01.1977 → 05.1988	OM 616.932	D	<b>106</b>			
U 65 T, U 70 T	01.1965 → 04.1966	OM 352.919	D	<b>136</b>			
U 80 T, U 90 T	05.1966 →	OM 352.984	D	<b>130</b>			
U 80 T, U 90 T	05.1969 →	OM 352.903	D	<b>130</b>			
<b>UX</b>							
Series 100	08.1996 →	OM 602.989	D	<b>85</b>			

M

					Reference	Item No.	
<b>1</b>	<b>72,2</b>						
<b>M 200</b>	<b>711</b>						
	06.2013 →	B (LA)	4	1197 cm <sup>3</sup> 4V	84 kW (114 PS)	73,10 mm	
	[4] M 30 x 28				A 200 054 00 00	50 007 814	
	[4] M 30 x 28					50 007 815	
	[4] M 30 x 28				A 200 050 08 00	50 007 816	
	[4] M 30 x 28					50 007 818	
	[4] M 30 x 28					50 007 819	
	[4] M 30 x 28					50 007 820	
	[4] M 30 x 28					50 007 821	
	[4] M 30 x 28				A 200 054 01 00	50 007 822	
	[4] M 30 x 28				A 200 054 02 00	50 007 823	
	[4] M 30 x 28				A 200 054 03 00	50 007 824	
	[4] M 30 x 28				A 200 054 14 00	50 007 825	
	[4] M 30 x 28				A 200 054 15 00	50 007 826	
	[4] M 30 x 28				A 200 054 16 00	50 007 827	
	[4] M 30 x 28				A 200 054 17 00	50 007 828	
	[4] M 30 x 28				A 200 054 18 00	50 007 830	
	[4] M 30 x 28				A 200 054 19 00	50 007 831	
	[4] M 30 x 28				A 200 054 20 00	50 007 832	
	[4] M 30 x 28				A 200 054 21 00	50 007 833	
	[4] M 30 x 28				A 200 054 22 00	50 007 834	
	[4] M 30 x 28				A 200 054 23 00	50 007 835	
	[4] M 30 x 28				A 200 054 04 00	50 007 836	
	[4] M 30 x 28				A 200 054 05 00	50 007 838	
	[4] M 30 x 28				A 200 054 06 00	50 007 839	
	[4] M 30 x 28				A 200 054 07 00	50 007 840	
	[4] M 30 x 28				A 200 054 08 00	50 007 841	
	[4] M 30 x 28				A 200 054 09 00	50 007 842	
	[4] M 30 x 28				A 200 054 10 00	50 007 843	
	[4] M 30 x 28				A 200 054 11 00	50 007 844	
	[4] M 30 x 28				A 200 054 24 00	50 007 845	
	[4] M 30 x 28				A 200 054 12 00	50 007 846	
	[4] M 30 x 28				A 200 054 13 00	50 007 847	
<b>2</b>	<b>73,5</b>						
<b>M 136</b>	<b>920</b>						
	06.1946 → 05.1950	B (NA)	4	1697 cm <sup>3</sup> 2V	33 kW (45 PS) 6,7	100,00 mm	
	IN [2] 35,2 x 8,8 x 122,0	S - -		- 45° - -	13 - III	A 181 053 00 01	2660
<b>3</b>	<b>73,5</b>						
<b>OM 636</b>	<b>915</b>						
	01.1949 →	D (NA)	4	1697 cm <sup>3</sup> 2V	29 kW (39 PS) 19	100,00 mm	
	IN [2] 32,0 x 9 x 135,8	S - -		- 45° - -	13 - III	A 636 053 01 01	2664
	IN [2] 32,0 x 9 x 136,5	S - Cr -		- 45° - -	13 - III	A 636 053 03 01	2691
	EX [2] 29,0 x 9 x 135,0	A/S - Cr -		- 45° - -	13 - III	A 636 050 00 27	2656
	IN [4] 14,00 x 9 x 59,5	G2				A 636 053 20 30	81-1662
	IN [4] 14,00 x 9 x 60,0	G2				A 636 053 12 29	81-2658
	IN [4] 14,00 x 9 x 68,0	G2				A 636 053 03 30	81-2612
	EX [4] 14,00 x 9 x 56,0	G2				A 646 053 01 82	81-1660
	EX [4] 14,00 x 9 x 63,0	G2				A 636 053 03 29	81-2624

M

					Reference	Item No.
<b>4</b>						
<b>M 120</b>	<b>000 - 002, 010 - 011</b>	B	4	1767 cm <sup>3</sup> 2V	38 kW (52 PS) 6,7:1	100,00 mm
<b>M 136</b>	<b>040, 042 - 044, 047 - 055, 060, 071 - 073, 921, 923, 926</b>	B	4	1767 cm <sup>3</sup> 2V	33-38 kW (45-52 PS)	100,00 mm
<b>M 136</b>	<b>922</b>					
	07.1953 → 09.1955	B (NA)	4	1767 cm <sup>3</sup> 2V	38 kW (52 PS) 6,7	100,00 mm
<b>M 191</b>	<b>010, 018</b>					
	01.1953 → 1957	B	4	1767 cm <sup>3</sup> 2V	33-38 kW (45-52 PS) 6,5/6,7:1	100,00 mm
	IN [2]	35,2 x 8,8 x 122,0	S - -	- 45° - -	13 - III	A 181 053 00 01 <b>2660</b>
<b>5</b>						
<b>OM 636</b>	<b>900, 916 - 919, 932 - 941, 944, 946 - 947, 955 - 957, 959 - 960</b>	D	4	1767 cm <sup>3</sup> 2V	15-32 kW (21-43 PS)	100,00 mm
	1949 →					
<b>OM 636</b>	<b>914, 930 - 931</b>	D (NA)	4	1767 cm <sup>3</sup> 2V	25-32 kW (34-44 PS)	100,00 mm
	01.1949 →					
	90 278 6..					
	IN [2]	32,0 x 9 x 135,8	S - -	- 45° - -	13 - III	A 636 053 01 01 <b>2664</b>
	IN [2]	32,0 x 9 x 136,5	S - Cr -	- 45° - -	13 - III	A 636 053 03 01 <b>2691</b>
	EX [2]	29,0 x 9 x 135,0	A/S - Cr -	- 45° - -	13 - III	A 636 050 00 27 <b>2656</b>
	IN [4]	14,00 x 9 x 59,5	G2			A 636 053 20 30 <b>81-1662</b>
	IN [4]	14,00 x 9 x 60,0	G2			A 636 053 12 29 <b>81-2658</b>
	IN [4]	14,00 x 9 x 68,0	G2			A 636 053 03 30 <b>81-2612</b>
	EX [4]	14,00 x 9 x 56,0	G2			A 646 053 01 82 <b>81-1660</b>
	EX [4]	14,00 x 9 x 63,0	G2			A 636 053 03 29 <b>81-2624</b>
<b>6</b>						
<b>OM 607 Euro 5</b>	<b>951</b>	D (A)	4	1461 cm <sup>3</sup> 2V	55-81 kW (75-110 PS)	80,50 mm
	06.2012 →					
	IN [2]	33,4 x 6 x 101,0	S - -	- 45° - -	22 - III	A 607 053 12 00 <b>539018</b>
	EX [2]	28,9 x 6 x 100,8	RA/S- -	- 45° - -	22 - III	A 607 053 13 00 <b>539017</b>
						A 626 050 09 00
	[50]	∅ 6 mm				A 000 053 11 26 <b>MK-6H</b>
	IN/EX [4]	11,05 x 6 x 40,5	B1			<b>81-51000</b> <small>NEW</small>
	IN/EX [4]	11,25/8.8 x 6 x 40,5	B1			<b>81-51001</b> <small>NEW</small>
						A 607 050 00 00 <b>50 007 076</b> <small>NEW</small> (1)
	(1) (ST)					
<b>7</b>						
<b>OM 608</b>	<b>915</b>	D (A)	4	1461 cm <sup>3</sup> 2V	59-85 kW (80-116 PS)	80,50 mm
	03.2018 →					
						A 607 050 00 00 <b>50 007 076</b> <small>NEW</small> (1)
	(1) (ST)					
<b>8</b>						
<b>OM 654</b>	<b>916</b>	D (A)	4	1598 cm <sup>3</sup> 4V	90-118 kW (122-160 PS)	83,60 mm
	05.2018 →					
	IN [2]	26,8 x 6 x 106,8	S - Cr -	- 45° - -	22 - III	A 654 053 03 00 <b>269000</b> <small>NEW</small>
	EX [2]	23,3 x 6 x 106,3	A/S - Cr -	- 45° - -	22 - III	A 654 050 40 00 <b>269001</b> <small>NEW</small>
Fortsetzung nächste Seite / continued on next page / suite page suivante / continuación página próxima / Продолжение на следующей странице						

					Reference	Item No.	
[50]	Ø 6 mm				A 000 053 11 26	<b>MK-6H</b>	
<b>9</b>	<b>80</b>						
<b>M 127</b>	<b>980, 982, 984</b>	01.1958 → 12.1965	B (NA) 6	2V	88 kW (120 PS)	72,80 mm	
<b>M 127</b>	<b>983</b>		B 6	2196 cm <sup>3</sup> 2V	85 kW (115 PS) 8,7:1	72,80 mm	
<b>M 180</b>	<b>922, 926 - 929, 940 - 943, 952 - 953</b>	1956 →	B (NA) 6	2195 cm <sup>3</sup> 2V	60-81 kW (82-110 PS)	72,80 mm	
<b>M 180</b>	<b>958</b>	01.1968 → 11.1976	B (NA) 6	2196 cm <sup>3</sup> 4V	60 kW (82 PS) 8,7:1	72,80 mm	
	IN [2]	39,2 x 9 x 128,0	S - -	- 45° - -	5 - III	A 180 053 02 01 A 180 053 04 01	<b>2666</b>
	EX [2]	35,1 x 10 x 112,7	A/S - -	- 45° - VS -	5 - III	A 180 053 11 05 A 180 053 15 05	<b>261119</b>
	IN [4]	14,00 x 9 x 65,5	B1			A 180 050 00 24 A 180 050 02 24	<b>81-2643</b>
	IN [4]	14,10 x 9 x 65,5	B1			A 180 050 03 24	<b>81-2691</b>
	IN [4]	14,10 x 9 x 67,0	B1			A 121 050 06 24	<b>81-2629</b>
	IN [4]	14,20 x 9 x 67,0	B1			A 121 050 02 24	<b>81-2640</b>
	EX [4]	14,00 x 10 x 57,0	B1			A 121 050 16 24	<b>81-2628</b>
	EX [4]	14,10 x 10 x 57,0	B1			A 121 050 21 24	<b>81-2630</b>
	EX [4]	14,20 x 10 x 57,0	B1			A 121 050 22 24	<b>81-2639</b>
<b>10</b>	<b>80</b>						
<b>M 166</b>	<b>940</b>	09.1997 → 08.2004	B (NA) 4	1397 cm <sup>3</sup> 2V	60 kW (82 PS) 11	69,50 mm	
	IN [2]	40,0 x 6 x 103,0	S - Ni -	- 45° - -	1 - III	A 166 053 01 01	<b>261036</b>
	EX [2]	34,0 x 7 x 102,7	A - Ni -	- 45° - VS -	1 -	A 166 050 03 27	<b>261037</b>
	IN/EX [4]	12,56 x 7.02 x 37,5	G1			A 111 053 10 29	<b>81-26172</b>
	IN/EX [4]	12,70 x 7.02 x 37,5	G1			A 111 053 11 29	<b>81-26173</b>
	IN [4]	12,50 x 6 x 37,5	G1			A 606 053 12 29	<b>81-26175</b>
						A 166 050 07 01	<b>50 007 591</b> (1)
	(1) Schalenhartguss/chilled cast iron/pièce moulée trempée en surface/fundición en coquilla/Отливка с отбелсным поверхностным слоем						
<b>11</b>	<b>80</b>						
<b>M 166</b>	<b>960 - 961</b>	09.1997 → 07.2005	B (NA) 4	1598 cm <sup>3</sup> 2V	60-75 kW (82-102 PS) 11	79,50 mm	
	IN [2]	40,0 x 6 x 103,0	S - Ni -	- 45° - -	1 - III	A 166 053 01 01	<b>261036</b>
	EX [2]	34,0 x 7 x 102,7	A - Ni -	- 45° - VS -	1 -	A 166 050 03 27	<b>261037</b>
	IN/EX [4]	12,56 x 7.02 x 37,5	G1			A 111 053 10 29	<b>81-26172</b>
	IN/EX [4]	12,70 x 7.02 x 37,5	G1			A 111 053 11 29	<b>81-26173</b>
	IN [4]	12,50 x 6 x 37,5	G1			A 606 053 12 29	<b>81-26175</b>
		AS				A 166 050 06 01	<b>50 007 590</b> (1)
	(1) Schalenhartguss/chilled cast iron/pièce moulée trempée en surface/fundición en coquilla/Отливка с отбелсным поверхностным слоем						
<b>12</b>	<b>80</b>						
<b>OM 668</b>	<b>914, 941</b>	07.1998 → 07.2005	D (A) 4	1689 cm <sup>3</sup> 4V	44-67 kW (60-91 PS) 19,5	84,00 mm	
<b>OM 668</b>	<b>940, 942</b>	09.1998 → 08.2004	D (LA) 4	1689 cm <sup>3</sup> 4V	55-70 kW (75-95 PS)	84,00 mm	

Fortsetzung nächste Seite / continued on next page / suite page suivante / continuación página próxima / Продолжение на следующей странице

					Reference	Item No.	
	IN [4] EX [4]	11,55 x 6 x 47,5 11,55 x 7 x 47,5	G1 G1		A 668 053 02 29 A 668 053 02 30	<b>81-16108</b> <b>81-16109</b>	
<b>13</b>		<b>80</b>					
<b>OM 622</b>	<b>951</b>	10.2014 →	D (A) 4	1598 cm <sup>3</sup> 4V	65-84 kW (88-114 PS) 15,4	79,50 mm	
<b>OM 626 Euro 6</b>	<b>951</b>	05.2014 → 05.2018	D (LA) 4	1598 cm <sup>3</sup> 4V	85-100 kW (116-136 PS) 15,4	79,50 mm	
40 892 6..							
	IN [2] EX [2]	23,5 x 6 x 104,2 23,4 x 6 x 104,1	S - - RA/S- -	- 45° - - - 45° - -	22 - III 22 - III	A 626 050 05 00 A 626 050 08 00	<b>539044</b> <b>539045</b>
	[50]	∅ 6 mm				A 000 053 11 26	<b>MK-6H</b>
	[4]					A 626 050 04 00	<b>50 007 711</b>
<b>14</b>		<b>80,4</b>					
<b>M 264 Euro 6</b>	<b>915</b>	04.2018 →	B (A) 4	1497 cm <sup>3</sup> 4V	95-145 kW (129-197 PS)	73,70 mm	
	IN [2] EX [2]	31,5 x 6 x 115,8 24,5 x 6 x 107,0	S - Cr - RA/S- Ni - Na	- 45° - - - 45° - -	22 - III 22 - III	A 264 053 01 00 A 270 053 00 01 A 264 053 02 00	<b>261148</b> <b>261154</b>
	[50]	∅ 6 mm				A 000 053 11 26	<b>MK-6H</b>
<b>15</b>		<b>81</b>					
<b>M 104</b>	<b>900</b>	08.1997 → 07.2003	B (NA) 6	2792 cm <sup>3</sup> 2V	128 kW (174 PS) 10,1	90,30 mm	
91 033 6..							
	IN [2] EX [2]	39,0 x 7 x 106,0 34,0 x 7 x 107,0	S - - RA/S- -	- 45° - VS - - 45° - VS -	22 - III 22 - III		<b>39372</b> <b>39300</b>
	[50]	∅ 7 mm					<b>MK-7H</b>
	IN/EX [4]	12,08/15 x 7 x 38,0	B1			A 000 012 00 14	<b>81-33100</b>
<b>16</b>		<b>81,5</b>					
<b>M 180</b>	<b>950</b>	07.1965 → 01.1968	B 6	2281 cm <sup>3</sup> 2V	88 kW (120 PS) 9	73,00 mm	
<b>M 180</b>	<b>945, 947, 949</b>	07.1965 → 02.1968	B (NA) 6	2281 cm <sup>3</sup> 2V	77-88 kW (105-120 PS) 9	73,00 mm	
	IN [2] EX [1]	41,0 x 9 x 128,0 37,1 x 11 x 113,2	S - Cr - A/S - Cr -	- 45° - - - 45° - -	9 - 9 - III	A 123 053 00 01 A 123 053 01 01 A 115 050 00 27 A 115 050 01 27 A 129 053 00 05 A 129 053 01 05 A 130 053 01 05 A 290 053 01 05	<b>2619</b> <b>261106</b>
	[50]	∅ 9 mm				A 115 053 00 26	<b>RK-9H</b>
	IN [4] IN [4] EX [4] EX [4]	14,04 x 9 x 55,0 14,24 x 9 x 55,0 15,04 x 11 x 45,0 15,24 x 11 x 45,0	B1 B1 B1 B1			A 130 050 01 24 A 130 050 02 24 A 108 050 05 24 A 108 050 07 24	<b>81-2667</b> <b>81-2668</b> <b>81-2659</b> <b>81-2660</b>

M



					Reference	Item No.		
<b>17</b>								
<b>M 271</b>	<b>951</b>							
41 725 6.., 41 811 6..	09.2008 →	BG (NA)	4	1796 cm <sup>3</sup>	4V	115 kW (156 PS) 9,5	85,00 mm	
	IN [2]	30,5 x 6 x 105,3	S - Cr -	- 45° -	-	22 - III	A 271 053 05 01 A 271 053 06 01	<b>261128</b>
	EX [2]	27,0 x 6 x 109,3	A/S - Cr -	- 45° -	VS -	22 - III	A 271 050 06 27	<b>261129</b>
	[50]	∅ 6 mm					A 000 053 11 26	<b>MK-6H</b>
	IN/EX [6]	12,53 x 6 x 43,5	B1					<b>81-11112</b>
	ES AS						A 271 051 18 01 A 271 051 21 01	<b>50 007 592</b> (1) <b>50 007 593</b> (1)
	(1)	Schalenhartguss/chilled cast iron/pièce moulée trempée en surface/fundición en coquilla/Отливка с отбеленным поверхностным слоем						
	[8]	H 12 x 34,6 x 34,6					A 160 050 01 80 A 642 050 00 80 A 642 050 01 80	<b>50 006 432</b>
<b>18</b>								
<b>M 271</b>	<b>958</b>							
41 725 6.., 41 811 6..	03.2011 → 12.2015	BG (K)	4	1796 cm <sup>3</sup>	4V	120-135 kW (163-184 PS) 9,5	85,00 mm	
	IN [2]	30,5 x 6 x 105,3	S - Cr -	- 45° -	-	22 - III	A 271 053 05 01 A 271 053 06 01	<b>261128</b>
	EX [2]	27,0 x 6 x 109,3	A/S - Cr -	- 45° -	VS -	22 - III	A 271 050 06 27	<b>261129</b>
	[50]	∅ 6 mm					A 000 053 11 26	<b>MK-6H</b>
	IN/EX [6]	12,53 x 6 x 43,5	B1					<b>81-11112</b>
	[8]	H 12 x 34,6 x 34,6					A 160 050 01 80 A 642 050 00 80 A 642 050 01 80	<b>50 006 432</b>
<b>19</b>								
<b>M 127</b>	<b>981</b>							
	01.1963 → 01.1967	B (NA)	6	2306 cm <sup>3</sup>	2V	110 kW (150 PS) 9,3	72,80 mm	
	IN [2]	39,2 x 9 x 128,0	S - -	- 45° -	-	5 - III	A 180 053 02 01 A 180 053 04 01	<b>2666</b>
	EX [2]	35,1 x 10 x 112,7	A/S - -	- 45° -	VS -	5 - III	A 180 053 11 05 A 180 053 15 05	<b>261119</b>
	IN [4]	14,04 x 9 x 55,0	B1				A 130 050 01 24	<b>81-2667</b>
	IN [4]	14,24 x 9 x 55,0	B1				A 130 050 02 24	<b>81-2668</b>
	EX [6]	14,00 x 10 x 50,0	B1				A 127 050 11 24	<b>81-2652</b>

M

						Reference	Item No.	
<b>20</b>	<b>82</b>							
<b>M 108</b>	<b>920, 924</b> 01.1966 →	B (NA) 6	2496 cm <sup>3</sup>	2V	85-96 kW	(116-131 PS)	78,80 mm	
<b>M 111/1A</b>		B 6	2294 cm <sup>3</sup>	2V	77 kW	(105 PS) 9:1	72,40 mm	
<b>M 114</b>	<b>923, 981</b>	B 6	2496 cm <sup>3</sup>	2V	85-110 kW	(116-150 PS)	78,80 mm	
<b>M 114</b>	<b>920, 980</b> 01.1968 → 08.1972	B (NA) 6	2496 cm <sup>3</sup>	2V	85-110 kW	(116-150 PS)	78,80 mm	
<b>M 127</b>	<b>945, 949</b>	B 6	2307 cm <sup>3</sup>	2V	110-111 kW	(150 PS) 9,3:1	72,80 mm	
<b>M 129</b>	<b>980 - 982</b> 01.1965 → 01.1968	B (NA) 6	2496 cm <sup>3</sup>	2V	110 kW	(150 PS) 9,3	78,80 mm	
<b>M 180</b>	<b>954 - 955</b> 01.1968 →	B (NA) 6	2292 cm <sup>3</sup>	2V	88 kW	(120 PS)	72,40 mm	
<b>M 180</b>	<b>951</b>	B (NA) 6	2306 cm <sup>3</sup>	2V	79 kW	(107 PS) 9:1	72,80 mm	
	IN [2] EX [1]	41,0 x 9 x 128,0 37,1 x 11 x 113,2	S - Cr - A/S - Cr -	- 45° - - 45° -	- -	9 - 9 - III	A 123 053 00 01 A 123 053 01 01 A 115 050 00 27 A 115 050 01 27 A 129 053 00 05 A 129 053 01 05 A 130 053 01 05 A 290 053 01 05	<b>2619</b> <b>261106</b>
	[50]	∅ 9 mm					A 115 053 00 26	<b>RK-9H</b>
	IN [4] IN [4] EX [4] EX [4]	14,04 x 9 x 55,0 14,24 x 9 x 55,0 15,04 x 11 x 45,0 15,24 x 11 x 45,0	B1 B1 B1 B1				A 130 050 01 24 A 130 050 02 24 A 108 050 05 24 A 108 050 07 24	<b>81-2667</b> <b>81-2668</b> <b>81-2659</b> <b>81-2660</b>
<b>21</b>	<b>82</b>							
<b>M 271</b>	<b>921, 940 - 942, 944, 946, 948, 956</b> 05.2002 → 06.2011	B (K) 4		4V	90-141 kW	(122-192 PS)	85,00 mm	
41 724 6.., 41 725 6.., 41 811 6..								
	IN [2] IN [2] EX [2] EX [2]	30,5 x 6 x 105,3 30,5 x 7 x 105,4 27,0 x 6 x 109,3 27,0 x 7 x 109,2	S - Cr - S - Cr - A/S - Cr - RA/S- Cr -	- 45° - - 45° - - 45° - VS - - 45° - VS -	- - - -	22 - III 1 - III 22 - III 1 - III	A 271 053 05 01 A 271 053 06 01 A 271 053 00 01 A 271 050 06 27 A 271 050 00 27 A 271 050 04 27	<b>261128</b> <b>261122</b> <b>261129</b> <b>261123</b>
	[50] [50]	∅ 7 mm ∅ 6 mm					A 000 053 11 26	<b>LK-2607</b> <b>MK-6H</b>
	IN/EX [4]	12,52 x 7 x 40,0	G2				A 137 053 02 30	<b>81-26184</b>
		ES AS					A 271 051 18 01 A 271 051 21 01	<b>50 007 592</b> (1) <b>50 007 593</b> (1)
(1) Schalenhartguss/chilled cast iron/pièce moulée trempée en surface/fundición en coquilla/Отливка с отбелсным поверхностным слоем								
	[8]	H 12 x 34,6 x 34,6					A 160 050 01 80 A 642 050 00 80 A 642 050 01 80	<b>50 006 432</b>
<b>22</b>	<b>82</b>							
<b>M 271</b>	<b>955</b> 10.2006 → 03.2010	B (K) 4	1796 cm <sup>3</sup>	4V	135 kW	(184 PS) 9,3	85,00 mm	
41 725 6.., 41 811 6..								
Fortsetzung nächste Seite / continued on next page / suite page suivante / continuación página próxima / Продолжение на следующей странице								

					Reference	Item No.
	IN [2] 30,5 x 6 x 105,3	S - Cr -	- 45° - -	22 - III	A 271 053 05 01 A 271 053 06 01	<b>261128</b>
	IN [2] 30,5 x 7 x 105,4	S - Cr -	- 45° - -	1 - III	A 271 053 00 01	<b>261122</b>
	EX [2] 27,0 x 6 x 109,3	A/S - Cr -	- 45° - VS -	22 - III	A 271 050 06 27	<b>261129</b>
	EX [2] 27,0 x 7 x 109,2	RA/S- Cr -	- 45° - VS -	1 - III	A 271 050 00 27 A 271 050 04 27	<b>261123</b>
	[50] Ø 6 mm				A 000 053 11 26	<b>MK-6H</b>
	IN/EX [4] 12,52 x 7 x 40,0	G2			A 137 053 02 30	<b>81-26184</b>
	ES AS				A 271 051 18 01 A 271 051 21 01	<b>50 007 592</b> (1) <b>50 007 593</b> (1)
	(1) Schalenhartguss/chilled cast iron/pièce moulée trempée en surface/fundición en coquilla/Отливка с отбелсным поверхностным слоем					
	[8] H 12 x 34,6 x 34,6				A 160 050 01 80 A 642 050 00 80 A 642 050 01 80	<b>50 006 432</b>

**23**

**82**

<b>M 271</b>	<b>910</b>								
	01.2008 → 08.2014	B (K)	4	1597 cm <sup>3</sup>	4V	105-115 kW	(143-156 PS)	10	75,60 mm
<b>M 271</b>	<b>950, 952, 954</b>								
	01.2007 → 08.2014	B (K)	4	1796 cm <sup>3</sup>	4V	115-135 kW	(156-184 PS)	9,5	85,00 mm

41 725 6.., 41 766 6.., 41 811 6..

	IN [2] 30,5 x 6 x 105,3	S - Cr -	- 45° - -	22 - III	A 271 053 05 01 A 271 053 06 01	<b>261128</b>
	EX [2] 27,0 x 6 x 109,3	A/S - Cr -	- 45° - VS -	22 - III	A 271 050 06 27	<b>261129</b>
	[50] Ø 6 mm				A 000 053 11 26	<b>MK-6H</b>
	IN/EX [4] 12,52 x 7 x 40,0	G2			A 137 053 02 30	<b>81-26184</b>
	ES AS				A 271 051 18 01 A 271 051 21 01	<b>50 007 592</b> (1) <b>50 007 593</b> (1)
	(1) Schalenhartguss/chilled cast iron/pièce moulée trempée en surface/fundición en coquilla/Отливка с отбелсным поверхностным слоем					
	[8] H 12 x 34,6 x 34,6				A 160 050 01 80 A 642 050 00 80 A 642 050 01 80	<b>50 006 432</b>

**24**

**82**

<b>M 271</b>	<b>861</b>								
	02.2011 →	B (LA)	4	1796 cm <sup>3</sup>	4V	135-150 kW	(184-204 PS)	9,3	85,00 mm
<b>M 271</b>	<b>820, 860</b>								
	01.2007 →	B (A)	4	1796 cm <sup>3</sup>	4V	115-150 kW	(156-204 PS)	9,3	85,00 mm

41 726 6.., 41 727 6..

	IN [2] 32,0 x 6 x 105,5	S - Cr -	- 45° - -	22 - III	A 271 053 10 01	<b>261142</b> <small>NEW</small>
	EX [2] 28,0 x 6 x 109,2	RA/S- Cr -	- 45° - VS -	22 - III	A 271 050 11 27	<b>261155</b> <small>NEW</small> (1)
	EX [2] 28,0 x 6 x 109,3	RA/S- Cr - Na	- 45° - VS -	22 - III		<b>261143</b> <small>NEW</small> (2)
	(1) IAM specification					
	(2) OES specification					
	[50] Ø 6 mm				A 000 053 11 26	<b>MK-6H</b>

Fortsetzung nächste Seite / continued on next page / suite page suivante / continuación página próxima / Продолжение на следующей странице

					Reference	Item No.
	IN/EX [6]	12,53 x 6 x 43,5	B1			<b>81-11112</b>
	[8]	H 12 x 34,6 x 34,6			A 160 050 01 80 A 642 050 00 80 A 642 050 01 80	<b>50 006 432</b>
<b>25</b>		<b>82</b>				
<b>M 271</b>	<b>911</b>					
	02.2009 → 06.2011	B (NA)	4	1597 cm <sup>3</sup>	4V	95 kW (129 PS) 10 75,60 mm
<b>M 271</b>	<b>957</b>					
	05.2008 → 06.2011	B (K)	4	1796 cm <sup>3</sup>	4V	120-135 kW (163-184 PS) 9,3 85,00 mm
41 725 6.., 41 766 6.., 41 811 6..						
	IN [2]	30,5 x 6 x 105,3	S - Cr -	- 45° -	- 22 - III	A 271 053 05 01 A 271 053 06 01 <b>261128</b>
	EX [2]	27,0 x 6 x 109,3	A/S - Cr -	- 45° - VS -	22 - III	A 271 050 06 27 <b>261129</b>
	[50]	∅ 6 mm				A 000 053 11 26 <b>MK-6H</b>
	IN/EX [6]	12,53 x 6 x 43,5	B1			<b>81-11112</b>
		ES AS				A 271 051 18 01 A 271 051 21 01 <b>50 007 592</b> (1) <b>50 007 593</b> (1)
	(1)	Schalenhartguss/chilled cast iron/pièce moulée trempée en surface/fundición en coquilla/Отливка с отбеленным поверхностным слоем				
	[8]	H 12 x 34,6 x 34,6				A 160 050 01 80 A 642 050 00 80 A 642 050 01 80 <b>50 006 432</b>
<b>26</b>		<b>82</b>				
<b>M 272</b>	<b>923</b>					
		B	6	2496 cm <sup>3</sup>	4V	78,80 mm
	IN [2]	37,0 x 6 x 109,4	S - Cr -	- 45° -	- 22 - III	A 272 053 02 01 A 272 053 08 01 <b>261130</b>
	EX [2]	28,0 x 6 x 107,4	A/S - Cr -	- 45° - VS -	22 - III	A 272 050 02 27 A 272 050 09 27 <b>261131</b>
<b>27</b>		<b>82</b>				
<b>OM 654</b>	<b>920</b>					
	01.2016 →	D (A)	4	1950 cm <sup>3</sup>	4V	84-235 kW (114-320 PS) 92,30 mm
<b>OM 656</b>	<b>929</b>					
	05.2017 →	D (LA)	6	2925 cm <sup>3</sup>	4V	183-250 kW (249-340 PS) 15,5 92,30 mm
41 829 6..						
	IN [2]	28,5 x 6 x 106,8	S - Cr -	- 45° -	- 22 - III	A 654 053 02 00 <b>261152</b> <small>NEW</small>
	EX [2]	24,6 x 6 x 106,2	ID/S - Cr -	- 45° -	- 22 - III	A 654 050 10 00 <b>261153</b> <small>NEW</small>
	[50]	∅ 6 mm				A 000 053 11 26 <b>MK-6H</b>
<b>28</b>		<b>82,9</b>				
<b>M 103</b>	<b>941</b>					
	09.1985 → 06.1991	B (NA)	6	2599 cm <sup>3</sup>	2V	118-122 kW (160-166 PS) 9,2 80,25 mm
<b>M 103</b>	<b>940, 942 - 943</b>					
	10.1982 → 08.1993	B (NA)	6	2597 cm <sup>3</sup>	2V	118-122 kW (160-166 PS) 80,30 mm
93 827 6..						
	IN [2]	40,0 x 8 x 110,2	S - Cr -	- 45° -	- 9 - III	A 103 053 21 01 A 103 053 23 01 <b>26107</b>
	EX [2]	35,0 x 9 x 110,9	A/S - Cr -	- 45° - VS -	9 - III	A 103 050 13 27 <b>261112</b> (1)
Fortsetzung nächste Seite / continued on next page / suite page suivante / continuación página próxima / Продолжение на следующей странице						

					Reference	Item No.	
(1)	Kegelstückfixierung/cotter fixation/fixation de clavettes/fijación de chavetas/Крепление конического сухаря Ø 8 mm						
[50]	Ø 8 mm				A 102 053 00 26	<b>RK-8H</b>	
IN [6] EX [6]	14,00 x 8 x 42,0 14,00 x 9 x 48,0	B1 B1			A 103 050 22 24 A 103 050 27 24	<b>81-26151</b> <b>81-26154</b>	
					A 103 050 64 01	<b>50 006 223</b> (2)	
(2)	Schalenhartguss/chilled cast iron/pièce moulée trempée en surface/fundición en coquilla/Отливка с отбеленным поверхностным слоем						
[8]	H 14 x 30				A 103 050 00 80	<b>50 006 454</b>	

## 29

### 83

<b>M 270</b>	<b>920</b>	05.2012 →	BG (A)	4	1991 cm <sup>3</sup>	4V	115-160 kW	(156-218 PS)	10,3:1	92,00 mm
<b>M 274</b>	<b>920</b>	11.2012 →	BG (LA)	4	1991 cm <sup>3</sup>	4V	115-245 kW	(156-333 PS)	9,8	92,00 mm

40 859 6..., 40 862 6..

IN [2]	31,5 x 6 x 115,8	S - Cr -	- 45° -	-	22 - III	A 264 053 01 00 A 270 053 00 01	<b>261148</b>
EX [2]	25,0 x 6 x 107,1	RA/S- Cr - Na	- 45° -	VS -	22 - III	A 270 050 01 00	<b>261149</b>
[50]	Ø 6 mm					A 000 053 11 26	<b>MK-6H</b>
[8]	H 12 x 34,6 x 34,6					A 160 050 01 80 A 642 050 00 80 A 642 050 01 80	<b>50 006 432</b>

## 30

### 83

<b>M 266</b>	<b>920</b>	09.2004 → 06.2012	B (NA)	4	1498 cm <sup>3</sup>	2V	70 kW	(95 PS)	11	69,20 mm
<b>M 266</b>	<b>940</b>	09.2004 → 06.2012	B (NA)	4	1699 cm <sup>3</sup>	2V	85 kW	(116 PS)	11	78,50 mm
<b>M 266</b>	<b>960</b>	09.2004 → 06.2012	B (NA)	4	2034 cm <sup>3</sup>	2V	85-100 kW	(116-136 PS)	11	94,00 mm
<b>M 266</b>	<b>980</b>	03.2005 → 06.2012	B (A)	4	2034 cm <sup>3</sup>	2V	142 kW	(193 PS)	11	94,00 mm

99 882 6..

IN [2]	43,0 x 6 x 103,0	S - Ni -	- 45° -	-	1 -	A 166 053 02 01	<b>261038</b>
EX [2]	35,0 x 7 x 102,7	A - Ni -	- 45° -	VS -	1 -	A 266 050 00 27 A 266 053 01 05	<b>261135</b>
[50]							<b>KK-6H</b>
IN/EX [4]	12,56 x 7.02 x 37,5	G1				A 111 053 10 29	<b>81-26172</b>
IN/EX [4]	12,70 x 7.02 x 37,5	G1				A 111 053 11 29	<b>81-26173</b>
IN [4]	12,50 x 6 x 37,5	G1				A 606 053 12 29	<b>81-26175</b>

## 31

### 83

<b>M 270</b>	<b>910</b>	11.2011 →	B (A)	4	1595 cm <sup>3</sup>	4V	75-115 kW	(102-156 PS)	10,3	73,70 mm
<b>M 274</b>	<b>910</b>	01.2008 →	B (A)	4	1595 cm <sup>3</sup>	4V	95-115 kW	(129-156 PS)	10,3	73,70 mm

40 853 6..., 40 856 6..

IN [2]	31,5 x 6 x 115,8	S - Cr -	- 45° -	-	22 - III	A 264 053 01 00 A 270 053 00 01	<b>261148</b>
EX [2]	25,0 x 6 x 107,1	RA/S- Cr - Na	- 45° -	VS -	22 - III	A 270 050 01 00	<b>261149</b>

Fortsetzung nächste Seite / continued on next page / suite page suivante / continuación página próxima / Продолжение на следующей странице



					Reference	Item No.
[50]	Ø 6 mm				A 000 053 11 26	<b>MK-6H</b>
[8]	H 12 x 34,6 x 34,6				A 160 050 01 80 A 642 050 00 80 A 642 050 01 80	<b>50 006 432</b>
[8]					A 270 050 01 33	<b>50 007 643</b>
<b>32</b>	<b>83</b>					
<b>M 260</b>	<b>920</b> 03.2018→	B (A)	4	1991 cm <sup>3</sup> 4V	140-225 kW (190-306 PS)	92,00 mm
<b>M 264 Euro 6</b>	<b>920</b> 10.2017→	B (LA)	4	1991 cm <sup>3</sup> 4V	145-220 kW (197-299 PS) 10	92,00 mm
IN [2]	31,5 x 6 x 115,8	S - Cr -	- 45° -	- 22 - III	A 264 053 01 00 A 270 053 00 01	<b>261148</b> <small>NEW</small>
EX [2]	24,5 x 6 x 107,0	RA/S- Ni - Na	- 45° -	- 22 - III	A 264 053 02 00	<b>261154</b> <small>NEW</small>
[50]	Ø 6 mm				A 000 053 11 26	<b>MK-6H</b>
<b>33</b>	<b>83</b>					
<b>OM 640</b>	<b>941</b> 09.2004→06.2012	D (LA)	4	1991 cm <sup>3</sup> 4V	100-103 kW (136-140 PS) 18	92,00 mm
<b>OM 640</b>	<b>940, 942</b> 09.2004→06.2012	D (A)	4	1991 cm <sup>3</sup> 4V	60-80 kW (82-109 PS) 18	92,00 mm
99 941 6..						
IN [2]	28,5 x 6 x 102,3	S - Cr -	- 45° -	- 22 - III	A 642 053 04 01	<b>261126</b>
EX [2]	25,4 x 6 x 102,3	RA/S- Cr -	- 45° -	- 22 - III	A 642 050 05 27 A 642 050 07 27 A 642 050 08 27	<b>261127</b>
[50]	Ø 6 mm				A 000 053 11 26	<b>MK-6H</b>
IN/EX [1]	11,55 x 6 x 34,5	G2				<b>81-26186</b> <small>NEW</small>
[8]	H 12 x 34,6 x 34,6				A 160 050 01 80 A 642 050 00 80 A 642 050 01 80	<b>50 006 432</b>
<b>34</b>	<b>83</b>					
<b>OM 642</b>	<b>820, 822, 826, 830, 832, 834 - 835, 870, 872, 884, 886, 890, 896, 898 - 899, 910, 920 - 921, 930, 932, 940, 950, 960 - 961, 970, 975, 990, 992 - 993</b> 01.2005→	D (LA)	6	2987 cm <sup>3</sup> 4V	135-200 kW (184-272 PS)	92,00 mm
<b>OM 642</b>	<b>836, 850, 856, 861 - 862, 868</b> 01.2009→	D (A)	6	2987 cm <sup>3</sup> 4V	150-190 kW (204-258 PS)	92,00 mm
40 095 6..., 40 096 6..., 41 713 6..., 41 714 6..						
IN [2]	28,5 x 6 x 102,3	S - Cr -	- 45° -	- 22 - III	A 642 053 04 01	<b>261126</b>
EX [2]	25,4 x 6 x 102,3	RA/S- Cr -	- 45° -	- 22 - III	A 642 050 05 27 A 642 050 07 27 A 642 050 08 27	<b>261127</b>
[50]	Ø 6 mm				A 000 053 11 26	<b>MK-6H</b>
IN/EX [1]	11,55 x 6 x 34,5	G2				<b>81-26186</b> <small>NEW</small>
	ES AS AS				A 642 050 28 01 A 642 050 46 01 A 642 050 35 01	<b>50 007 693</b> (1) <b>50 007 694</b> (2) <b>50 007 695</b> (1)
Fortsetzung nächste Seite / continued on next page / suite page suivante / continuación página próxima / Продолжение на следующей странице						

					Reference	Item No.
(1)	Schalenhartguss/chilled cast iron/pièce moulée trempée en surface/fundición en coquilla/Отливка с отбеленным поверхностным слоем links left gauche izquierda слева					
(2)	Schalenhartguss/chilled cast iron/pièce moulée trempée en surface/fundición en coquilla/Отливка с отбеленным поверхностным слоем rechts right à droite derecha справа					
[8]	H 12 x 34,6 x 34,6				A 160 050 01 80 A 642 050 00 80 A 642 050 01 80	<b>50 006 432</b>

<b>35</b>		<b>83</b>
<b>OM 642</b>	<b>864</b>	
	06.2011 → 02.2015	D (A) 6 2987 cm <sup>3</sup> 4V 190 kW (258 PS) 15,5 92,00 mm
<b>OM 642</b>	<b>986</b>	
	06.2006 →	D (LA) 6 2987 cm <sup>3</sup> 4V 135-140 kW (184-190 PS) 16,5:1 92,00 mm

	ES				A 642 050 28 01	<b>50 007 693</b> (1)
	AS				A 642 050 46 01	<b>50 007 694</b> (2)
	AS				A 642 050 35 01	<b>50 007 695</b> (1)
(1)	Schalenhartguss/chilled cast iron/pièce moulée trempée en surface/fundición en coquilla/Отливка с отбеленным поверхностным слоем links left gauche izquierda слева					
(2)	Schalenhartguss/chilled cast iron/pièce moulée trempée en surface/fundición en coquilla/Отливка с отбеленным поверхностным слоем rechts right à droite derecha справа					

<b>36</b>		<b>83</b>
<b>OM 651</b>	<b>911 - 912, 916, 924 - 925, 940, 960 - 961, 980</b>	
	02.2008 →	D (A) 4 2143 cm <sup>3</sup> 4V 70-152 kW (95-207 PS) 16,2 99,00 mm
<b>OM 651</b>	<b>913, 956 - 957</b>	
	06.2006 →	D (LA) 4 2143 cm <sup>3</sup> 4V 70-120 kW (95-163 PS) 16,2 99,00 mm
<b>OM 651 Filter</b>	<b>955</b>	
	06.2006 →	D (A) 4 2143 cm <sup>3</sup> 4V 70-120 kW (95-163 PS) 16,2 99,00 mm
40 776 6..., 40 809 6..., 41 711 6..., 41 712 6..., 41 716 6...		

	IN [2] EX [2]	28,5 x 6 x 108,8 24,6 x 6 x 109,2	S - Cr - A/S - Cr -	- 45° - - - 45° - -	22 - III 22 - III	A 651 053 01 01 A 651 050 01 27	<b>261140</b> <b>261141</b>
	[50]	∅ 6 mm				A 000 053 11 26	<b>MK-6H</b>
	IN/EX [1]	11,04 x 6 x 41,0	G2				<b>81-26187</b>
	ES					A 651 050 02 00 A 651 050 10 01	<b>50 007 671</b> (1)
	AS					A 651 050 03 00 A 651 050 09 01	<b>50 007 672</b> (2)

Fortsetzung nächste Seite / continued on next page / suite page suivante / continuación página próxima / Продолжение на следующей странице

					Reference	Item No.
(1) Motornummer/engine number/numéro de moteur/número de motor/номера двигателя: 31393897 Schraube M11 x 1,5 x 52 screw M11 x 1,5 x 52 la vis M11 x 1,5 x 52 el tornillo M11 x 1,5 x 52 болт M11 x 1,5 x 52	(2) Schraube M11 x 1,5 x 52 screw M11 x 1,5 x 52 la vis M11 x 1,5 x 52 el tornillo M11 x 1,5 x 52 болт M11 x 1,5 x 52					
[8]	H 12				A 651 050 00 80	<b>50 007 640</b>
[4]					A 651 050 00 33	<b>50 007 641</b>
	- - G - S -	- SB - -			A 651 010 11 20 A 651 010 27 20 A 651 010 84 18	<b>50 003 126</b>
				20 Nm 60 Nm 90° 90°		

**M**
**37** **83**

<b>OM 642</b>	<b>838, 852 - 853, 858</b>	11.2009 → 12.2017	D (A)	6	2987 cm <sup>3</sup>	4V	170-195 kW	(231-265 PS)	15,5	92,00 mm
<b>OM 642</b>	<b>854, 887</b>	09.2011 →	D (LA)	6	2987 cm <sup>3</sup>	4V	180-195 kW	(245-265 PS)		92,00 mm

41 079 6..., 41 080 6..

IN [2] EX [2]	28,5 x 6 x 102,3 25,4 x 6 x 102,3	S - Cr - RA/S- Cr -	- 45° - - - 45° - -	22 - III 22 - III	A 642 053 04 01 A 642 050 05 27 A 642 050 07 27 A 642 050 08 27	<b>261126</b> <b>261127</b>
[50]	∅ 6 mm				A 000 053 11 26	<b>MK-6H</b>
IN/EX [1]	11,55 x 6 x 34,5	G2				<b>81-26186</b>
	ES AS				A 642 050 28 01 A 642 050 35 01	<b>50 007 693</b> (1) <b>50 007 695</b> (1)
(1) Schalenhartguss/chilled cast iron/pièce moulée trempée en surface/fundición en coquilla/Отливка с отбелсным поверхностным слоем links left gauche izquierda слева						
[8]	H 12 x 34,6 x 34,6				A 160 050 01 80 A 642 050 00 80 A 642 050 01 80	<b>50 006 432</b>

**38** **83**

<b>OM 651</b>	<b>901</b>	11.2011 → 10.2014	D (LA)	4	1796 cm <sup>3</sup>	4V	80-100 kW	(109-136 PS)	16,2	83,00 mm
---------------	------------	-------------------	--------	---	----------------------	----	-----------	--------------	------	----------

41 641 6..

IN [2] EX [2]	28,5 x 6 x 108,8 24,6 x 6 x 109,2	S - Cr - A/S - Cr -	- 45° - - - 45° - -	22 - III 22 - III	A 651 053 01 01 A 651 050 01 27	<b>261140</b> <b>261141</b>
------------------	--------------------------------------	------------------------	------------------------	----------------------	------------------------------------	--------------------------------

Fortsetzung nächste Seite / continued on next page / suite page suivante / continuación página próxima / Продолжение на следующей странице

					Reference	Item No.
[50]	Ø 6 mm				A 000 053 11 26	<b>MK-6H</b>
IN/EX [1]	11,04 x 6 x 41,0	G2				<b>81-26187</b>
	ES AS				A 651 050 06 00 A 651 050 13 01	<b>50 007 696</b> (1) <b>50 007 697</b> (1)
	(1) Schalenhartguss/chilled cast iron/pièce moulée trempée en surface/fundición en coquilla/Отливка с отбеленным поверхностным слоем					
[8]	H 12				A 651 050 00 80	<b>50 007 640</b>
[4]					A 651 050 00 33	<b>50 007 641</b>

**39**

**83**
**OM 651**
**930**

11.2011 →

D (LA)

4

 2143 cm<sup>3</sup> 4V

80-130 kW

(109-177 PS)

16,2

99,00 mm

**OM 651**
**921**

02.2014 → 04.2019

D (A)

4

 2143 cm<sup>3</sup> 4V

100-150 kW

(136-204 PS)

99,00 mm

40 809 6.., 41 711 6.., 41 712 6.., 41 716 6..

IN [2] EX [2]	28,5 x 6 x 108,8 24,6 x 6 x 109,2	S - Cr - A/S - Cr -	- 45° - - 45° -	- -	22 - III 22 - III	A 651 053 01 01 A 651 050 01 27	<b>261140</b> <b>261141</b>
[50]	Ø 6 mm					A 000 053 11 26	<b>MK-6H</b>
IN/EX [1]	11,04 x 6 x 41,0	G2					<b>81-26187</b>
	ES AS					A 651 050 02 00 A 651 050 10 01 A 651 050 03 00 A 651 050 09 01	<b>50 007 671</b> (1) <b>50 007 672</b> (2)
	(1) Motornummer/engine number/numéro de moteur/número de motor/номера двигателя: 31393897 Schraube M11 x 1,5 x 52 screw M11 x 1,5 x 52 la vis M11 x 1,5 x 52 el tornillo M11 x 1,5 x 52 болт M11 x 1,5 x 52						
	(2) Schraube M11 x 1,5 x 52 screw M11 x 1,5 x 52 la vis M11 x 1,5 x 52 el tornillo M11 x 1,5 x 52 болт M11 x 1,5 x 52						
[8]	H 12					A 651 050 00 80	<b>50 007 640</b>
[4]						A 651 050 00 33	<b>50 007 641</b>

**40**

**83**
**OM 642**
**867**

02.2014 → 05.2017

D (A)

6

 2987 cm<sup>3</sup> 4V

185-190 kW

(252-258 PS)

92,00 mm

IN [2] EX [2]	28,5 x 6 x 102,3 25,4 x 6 x 102,3	S - Cr - RA/S- Cr -	- 45° - - 45° -	- -	22 - III 22 - III	A 642 053 04 01 A 642 050 05 27 A 642 050 07 27 A 642 050 08 27	<b>261126</b> <b>261127</b>
------------------	--------------------------------------	------------------------	--------------------	--------	----------------------	--	--------------------------------

Fortsetzung nächste Seite / continued on next page / suite page suivante / continuación página próxima / Продолжение на следующей странице

					Reference	Item No.
[50]	Ø 6 mm				A 000 053 11 26	<b>MK-6H</b>
	ES AS AS				A 642 050 28 01 A 642 050 46 01 A 642 050 35 01	<b>50 007 693</b> (1) <b>50 007 694</b> (2) <b>50 007 695</b> (1)
	(1) Schalenhartguss/chilled cast iron/pièce moulée trempée en surface/fundición en coquilla/Отливка с отбеленным поверхностным слоем links left gauche izquierda слева					
	(2) Schalenhartguss/chilled cast iron/pièce moulée trempée en surface/fundición en coquilla/Отливка с отбеленным поверхностным слоем rechts right à droite derecha справа					
[8]	H 12 x 34,6 x 34,6				A 160 050 01 80 A 642 050 00 80 A 642 050 01 80	<b>50 006 432</b>

**M**
**41** **83**
**OM 651**
**950**

03.2014 →

D (A)

4

 2143 cm<sup>3</sup> 4V

84-140 kW

(114-190 PS) 16,2

99,00 mm

40 809 6.., 41 712 6..

IN/EX [1]	11,04 x 6 x 41,0	G2				<b>81-26187</b>
	ES AS				A 651 050 02 00 A 651 050 10 01 A 651 050 03 00 A 651 050 09 01	<b>50 007 671</b> (1) <b>50 007 672</b> (2)
	(1) Motornummer/engine number/numéro de moteur/número de motor/номера двигателя: 31393897 Schraube M11 x 1,5 x 52 screw M11 x 1,5 x 52 la vis M11 x 1,5 x 52 el tornillo M11 x 1,5 x 52 болт M11 x 1,5 x 52					
	(2) Schraube M11 x 1,5 x 52 screw M11 x 1,5 x 52 la vis M11 x 1,5 x 52 el tornillo M11 x 1,5 x 52 болт M11 x 1,5 x 52					
[8]	H 12				A 651 050 00 80	<b>50 007 640</b>
[4]					A 651 050 00 33	<b>50 007 641</b>

**42** **83**
**OM 642**
**824**

03.2015 → 10.2019

D (LA)

6

 2987 cm<sup>3</sup> 4V

190 kW

(258 PS) 18

92,00 mm

	AS AS				A 642 050 46 01 A 642 050 35 01	<b>50 007 694</b> (1) <b>50 007 695</b> (2)
--	----------	--	--	--	------------------------------------	--

Fortsetzung nächste Seite / continued on next page / suite page suivante / continuación página próxima / Продолжение на следующей странице



					Reference	Item No.
(1)	Schalenhartguss/chilled cast iron/pièce moulée trempée en surface/fundición en coquilla/Отливка с отбеленным поверхностным слоем rechts right à droite derecha справа					
(2)	Schalenhartguss/chilled cast iron/pièce moulée trempée en surface/fundición en coquilla/Отливка с отбеленным поверхностным слоем links left gauche izquierda слева					

<b>43</b>		<b>83</b>
<b>OM 642</b>	<b>855</b>	
41 079 6.., 41 080 6..	01.2016 →	D (A) 6 2987 cm <sup>3</sup> 4V 190 kW (258 PS) 92,00 mm

	IN [2] EX [2]	28,5 x 6 x 102,3 25,4 x 6 x 102,3	S - Cr - RA/S- Cr -	- 45° - - - 45° - -	22 - III 22 - III	A 642 053 04 01 A 642 050 05 27 A 642 050 07 27 A 642 050 08 27	<b>261126</b> <b>261127</b>
	[50]	Ø 6 mm				A 000 053 11 26	<b>MK-6H</b>
	IN/EX [1]	11,55 x 6 x 34,5	G2				<b>81-26186</b>
	ES					A 642 050 28 01	<b>50 007 693</b> (1)
(1)	Schalenhartguss/chilled cast iron/pièce moulée trempée en surface/fundición en coquilla/Отливка с отбеленным поверхностным слоем links left gauche izquierda слева						
	[8]	H 12 x 34,6 x 34,6				A 160 050 01 80 A 642 050 00 80 A 642 050 01 80	<b>50 006 432</b>

<b>44</b>		<b>83</b>
<b>OM 642</b>	<b>873</b>	
41 079 6.., 41 080 6..	10.2016 →	D (LA) 6 2987 cm <sup>3</sup> 4V 190 kW (258 PS) 92,00 mm

	IN/EX [1]	11,55 x 6 x 34,5	G2				<b>81-26186</b>
--	-----------	------------------	----	--	--	--	-----------------

<b>45</b>		<b>83</b>
<b>OM 651</b>	<b>958</b>	
	02.2018 →	D (LA) 4 2143 cm <sup>3</sup> 4V 84-120 kW (114-163 PS) 16,2 99,00 mm

	IN [2] EX [2]	28,5 x 6 x 108,8 24,6 x 6 x 109,2	S - Cr - A/S - Cr -	- 45° - - - 45° - -	22 - III 22 - III	A 651 053 01 01 A 651 050 01 27	<b>261140</b> <b>261141</b>
	[50]	Ø 6 mm				A 000 053 11 26	<b>MK-6H</b>
	ES					A 651 050 02 00 A 651 050 10 01	<b>50 007 671</b> (1)
	AS					A 651 050 03 00 A 651 050 09 01	<b>50 007 672</b> (2)

Fortsetzung nächste Seite / continued on next page / suite page suivante / continuación página próxima / Продолжение на следующей странице

					Reference	Item No.
(1)	Motornummer/engine number/numéro de moteur/número de motor/номера двигателя: 31393897 Schraube M11 x 1,5 x 52 screw M11 x 1,5 x 52 la vis M11 x 1,5 x 52 el tornillo M11 x 1,5 x 52 болт M11 x 1,5 x 52					
(2)	Schraube M11 x 1,5 x 52 screw M11 x 1,5 x 52 la vis M11 x 1,5 x 52 el tornillo M11 x 1,5 x 52 болт M11 x 1,5 x 52					
[8]	H 12				A 651 050 00 80	<b>50 007 640</b>
[4]					A 651 050 00 33	<b>50 007 641</b>

**46**
**83**
**OM 642**
**889**

 07.2018 → 05.2020 D (A) 6 2987 cm<sup>3</sup> 4V 190 kW (258 PS) 92,00 mm

	ES AS				A 642 050 28 01 A 642 050 46 01	<b>50 007 693</b> (1) <b>50 007 694</b> (2)
(1)	Schalenhartguss/chilled cast iron/pièce moulée trempée en surface/fundición en coquilla/Отливка с отбелсным поверхностным слоем links left gauche izquierda слева					
(2)	Schalenhartguss/chilled cast iron/pièce moulée trempée en surface/fundición en coquilla/Отливка с отбелсным поверхностным слоем rechts right à droite derecha справа					

**47**
**83,2**
**M 112**
**910 - 911**

 06.1997 → 03.2003 B (NA) 6 2398 cm<sup>3</sup> 3V 125 kW (170 PS) 73,50 mm

	IN [2] EX [2]	30,0 x 7 x 120,6 34,0 x 7 x 121,6	S - Ni - A - Ni -	- 45° - - 45° - VS -	1 - 1 -	A 113 053 00 01 A 113 050 01 27	<b>261030</b> <b>261031</b>
[50]		Ø 7 mm					<b>LK-2607</b>
	IN/EX [4]	12,74 x 7 x 50,0	G1			A 113 053 03 29	<b>81-26183</b>
	IN [4] IN [4] EX [4]					A 113 050 01 33 A 113 050 00 33 A 113 050 00 34 A 113 050 05 34	<b>50 006 495</b> (1) <b>50 006 497</b> (2) <b>50 006 499</b>
(1)	Einlassventil/intake valve/soupape d'admission/válvula de admisión/впускной клапан No.2						
(2)	Einlassventil/intake valve/soupape d'admission/válvula de admisión/впускной клапан No.1						

**48**
**84**
**M 166**
**990 - 991**

 03.1999 → 07.2005 B (NA) 4 1898 cm<sup>3</sup> 2V 92 kW (125 PS) 10,8 85,60 mm

**M 166**
**995**

 12.2001 → 08.2004 B (NA) 4 2084 cm<sup>3</sup> 2V 103 kW (140 PS) 11 94,00 mm

Fortsetzung nächste Seite / continued on next page / suite page suivante / continuación página próxima / Продолжение на следующей странице

					Reference	Item No.	
	IN [2] EX [2]	43,0 x 6 x 103,0 36,0 x 7 x 102,7	S - Ni - A - Ni -	- 45° - - - 45° - -	1 - 1 -	A 166 053 02 01 A 166 050 04 27	<b>261038</b> <b>261039</b>
	IN/EX [4] IN/EX [4] IN [4]	12,56 x 7.02 x 37,5 12,70 x 7.02 x 37,5 12,50 x 6 x 37,5	G1 G1 G1			A 111 053 10 29 A 111 053 11 29 A 606 053 12 29	<b>81-26172</b> <b>81-26173</b> <b>81-26175</b>
<b>49</b>		<b>84,5</b>					
<b>M 136</b>		<b>925</b>					
		07.1953 → 12.1962	B (NA) 4	1884 cm <sup>3</sup> 2V	48 kW	(65 PS) 6,7	84,00 mm
	IN [2]	35,2 x 8,8 x 122,0	S - -	- 45° - -	13 - III	A 181 053 00 01	<b>2660</b>
<b>50</b>		<b>84,5</b>					
<b>M 121</b>		<b>924</b>					
		04.1961 → 08.1965	B (NA) 4	1884 cm <sup>3</sup> 2V	59 kW	(80 PS) 8,8	84,00 mm
	IN [2] EX [2]	44,0 x 9 x 128,0 37,0 x 10 x 112,7	S - - RA/S- Cr -	- 45° - - - 45° - VS -	5 - III 5 - III	A 121 053 00 01 A 121 053 15 05	<b>2675</b> <b>261121</b>
	IN [4] IN [4] EX [4] EX [4] EX [4]	14,10 x 9 x 67,0 14,20 x 9 x 67,0 14,00 x 10 x 57,0 14,10 x 10 x 57,0 14,20 x 10 x 57,0	B1 B1 B1 B1 B1			A 121 050 06 24 A 121 050 02 24 A 121 050 16 24 A 121 050 21 24 A 121 050 22 24	<b>81-2629</b> <b>81-2640</b> <b>81-2628</b> <b>81-2630</b> <b>81-2639</b>
<b>51</b>		<b>85</b>					
<b>M 121</b>		<b>926, 929</b>					
		06.1961 → 08.1965	B (NA) 4	1897 cm <sup>3</sup> 2V	50-59 kW	(68-80 PS) 8,8:1	83,60 mm
<b>M 121</b>		<b>922</b>					
		01.1955 → 1961	B 4	1897 cm <sup>3</sup> 2V	48 kW	(65 PS) 8,5:1	83,60 mm
	IN [2] EX [2]	44,0 x 9 x 128,0 37,0 x 10 x 112,7	S - - RA/S- Cr -	- 45° - - - 45° - VS -	5 - III 5 - III	A 121 053 00 01 A 121 053 15 05	<b>2675</b> <b>261121</b>
	IN [4] IN [4] EX [4] EX [4] EX [4]	14,10 x 9 x 67,0 14,20 x 9 x 67,0 14,00 x 10 x 57,0 14,10 x 10 x 57,0 14,20 x 10 x 57,0	B1 B1 B1 B1 B1			A 121 050 06 24 A 121 050 02 24 A 121 050 16 24 A 121 050 21 24 A 121 050 22 24	<b>81-2629</b> <b>81-2640</b> <b>81-2628</b> <b>81-2630</b> <b>81-2639</b>
<b>52</b>		<b>85,3</b>					
<b>M 111</b>		<b>920 - 921</b>					
		03.1993 → 09.2000	B (NA) 4	1799 cm <sup>3</sup> 4V	89-90 kW	(121-122 PS)	78,70 mm
	[50]	∅ 7 mm					<b>MK-7H</b>
	IN/EX [4] IN/EX [4]	12,56 x 7.02 x 37,5 12,70 x 7.02 x 37,5	G1 G1			A 111 053 10 29 A 111 053 11 29	<b>81-26172</b> <b>81-26173</b>
	[8]	H 35 x 24 x 24				A 104 050 12 25	<b>50 006 421</b>
<b>53</b>		<b>86</b>					
<b>M 110</b>		<b>921 - 923, 931 - 932, 981 - 986, 991 - 992</b>					
		06.1972 →	B (NA) 6	2746 cm <sup>3</sup> 2V	101-136 kW	(137-185 PS)	78,80 mm
93 582 6..							
Fortsetzung nächste Seite / continued on next page / suite page suivante / continuación página próxima / Продолжение на следующей странице							

M

					Reference	Item No.
	IN [2] 45,0 x 9 x 115,0	S - Cr -	- 45° - VS -	9 - III	A 110 050 07 26 A 110 053 05 01 A 110 053 06 01	<b>2635</b> (1)
	IN [2] EX [2] 45,0 x 9 x 115,1 39,1 x 9 x 118,2	S - Cr - A/S - Cr -	- 45° - - - 45° - VS -	9 - 9 - III	A 117 050 00 27 A 117 050 01 27	<b>261110</b> <b>261111</b> (2)
	EX [1] (1) OES specification (2) IAM specification (3) Kegelstückfixierung/cotter fixation/fixation de clavettes/fijación de chavetas/Крепление конического сухаря Ø 9 mm	A/S - Cr -	- 45° - -	9 - III	A 110 050 00 27	<b>261108</b> (3)
	[50] Ø 9 mm				A 115 053 00 26	<b>RK-9H</b>
	IN [6] EX [4] 14,04 x 9 x 51,5 15,04 x 11 x 54,0	B1 B1			A 110 050 26 24 A 110 050 54 24 A 110 050 65 24	<b>81-2679</b> <b>81-26136</b>
<b>54</b>	<b>86</b>	<b>M 110</b> <b>924, 926, 987 - 990, 994</b> 08.1974 → 05.1993 B (NA) 6 2746 cm <sup>3</sup> 2V 110-136 kW (150-185 PS) 78,80 mm				
93 582 6..						
	IN [2] 45,0 x 9 x 115,0	S - Cr -	- 45° - VS -	9 - III	A 110 050 07 26 A 110 053 05 01 A 110 053 06 01	<b>2635</b> (1)
	IN [2] EX [2] 45,0 x 9 x 115,1 39,1 x 9 x 118,2	S - Cr - A/S - Cr -	- 45° - - - 45° - VS -	9 - 9 - III	A 117 050 00 27 A 117 050 01 27	<b>261110</b> <b>261111</b> (2)
	(1) OES specification (2) IAM specification					
	[50] Ø 9 mm				A 115 053 00 26	<b>RK-9H</b>
	IN [6] EX [6] EX [6] 14,04 x 9 x 51,5 15,04 x 9 x 54,0 15,04 x 9 x 54,0	B1 B1 B1			A 110 050 26 24 A 110 050 54 24 A 110 050 58 24 A 110 050 41 24	<b>81-2679</b> <b>81-26124</b> <b>81-2696</b>
<b>55</b>	<b>86</b>	<b>M 123</b> <b>920 - 921</b> 02.1976 → B (NA) 6 2525 cm <sup>3</sup> 2V 95-103 kW (129-140 PS) 72,50 mm				
	IN [2] EX [1] 41,0 x 9 x 128,0 37,1 x 11 x 113,2	S - Cr - A/S - Cr -	- 45° - - - 45° - -	9 - 9 - III	A 123 053 00 01 A 123 053 01 01 A 115 050 00 27 A 115 050 01 27 A 129 053 00 05 A 129 053 01 05 A 130 053 01 05 A 290 053 01 05	<b>2619</b> <b>261106</b>
	[50] Ø 9 mm				A 115 053 00 26	<b>RK-9H</b>
	IN [4] IN [4] EX [4] EX [4] 14,04 x 9 x 55,0 14,24 x 9 x 55,0 15,04 x 11 x 45,0 15,24 x 11 x 45,0	B1 B1 B1 B1			A 130 050 01 24 A 130 050 02 24 A 108 050 05 24 A 108 050 07 24	<b>81-2667</b> <b>81-2668</b> <b>81-2659</b> <b>81-2660</b>

					Reference	Item No.
<b>56</b>	<b>86</b>					
<b>OM 628</b>	<b>960 - 963</b> 06.2000 →	D (LA)	8	3996 cm <sup>3</sup>	4V 184-191 kW (250-260 PS) 18,5	86,00 mm
<b>OM 629</b>	<b>910 - 912</b> 01.2006 → 12.2013	D (LA)	8	3996 cm <sup>3</sup>	4V 225-235 kW (306-320 PS)	86,00 mm
	IN [2] 28,7 x 7 x 104,1 EX [2] 26,2 x 7 x 104,5 (1) Kegelstückfixierung/cotter fixation/fijación de chavetas/fijación de chavetas/Крепление конического сухаря Ø 6 mm	S - Ni - RA/S- Ni -	- 45° - - - 45° - -	1 - 1 -	A 628 053 00 01 A 646 053 00 01 A 628 053 00 05	<b>261124</b> (1) <b>261125</b> (1)
	[50] Ø 6 mm				A 000 053 10 26	<b>LK-6H</b>
	IN/EX [4] 12,57 x 7 x 37,5 IN/EX [4] 12,76 x 7 x 37,5	G2 G2			A 611 053 03 29	<b>81-26182</b> <b>81-26185</b>
	[8] H 33 x 24,2 x 24,2				A 611 050 00 25 A 611 050 02 25	<b>50 006 424</b>
<b>57</b>	<b>86,5</b>					
<b>M 130</b>	<b>920, 922 - 923, 980 - 981, 983 - 984</b> 01.1967 → 11.1976	B (NA)	6		2V 96-125 kW (130-170 PS)	78,80 mm
<b>M 130</b>	<b>921, 924 - 925, 933</b> 11.1967 →	B	6	2778 cm <sup>3</sup>	2V 81-92 kW (110-125 PS)	78,80 mm
	IN [2] 41,0 x 9 x 128,0 EX [1] 37,1 x 11 x 113,2	S - Cr - A/S - Cr -	- 45° - - - 45° - -	9 - 9 - III	A 123 053 00 01 A 123 053 01 01 A 115 050 00 27 A 115 050 01 27 A 129 053 00 05 A 129 053 01 05 A 130 053 01 05 A 290 053 01 05	<b>2619</b> <b>261106</b>
	[50] Ø 9 mm				A 115 053 00 26	<b>RK-9H</b>
	IN [4] 14,04 x 9 x 55,0 IN [4] 14,24 x 9 x 55,0 EX [4] 15,04 x 11 x 45,0 EX [4] 15,24 x 11 x 45,0	B1 B1 B1 B1			A 130 050 01 24 A 130 050 02 24 A 108 050 05 24 A 108 050 07 24	<b>81-2667</b> <b>81-2668</b> <b>81-2659</b> <b>81-2660</b>
<b>58</b>	<b>87</b>					
<b>M 115</b>	<b>I, II</b> 01.1968 → 12.1972	B	4	1990 cm <sup>3</sup>	2V 55-63 kW (75-85 PS) 9	83,60 mm
<b>M 115</b>	<b>923, 926, 938 - 939</b> 07.1965 → 08.1980	B (NA)	4	1988 cm <sup>3</sup>	2V 62-70 kW (84-95 PS) 9	83,60 mm
<b>M 115</b>	<b>900, 920 - 921, 924, 927 - 929</b> 01.1968 → 12.1974	B (NA)	4	2197 cm <sup>3</sup>	2V 40-77 kW (54-105 PS)	92,40 mm
<b>M 115</b>	<b>922, 932 - 935</b> 01.1968 →	B	4	2197 cm <sup>3</sup>	2V 48-62 kW (65-85 PS) 9:1	92,40 mm
<b>M 121</b>	<b>941 - 942, 944</b> 08.1965 → 02.1968	B	4	1988 cm <sup>3</sup>	2V 50-59 kW (68-80 PS) 9:1	83,60 mm
<b>M 121</b>	<b>940, 943</b> 07.1965 → 02.1968	B (NA)	4	1988 cm <sup>3</sup>	2V 59-61 kW (80-83 PS)	83,60 mm
91 430 6..						
	IN [2] 44,0 x 9 x 128,0 EX [1] 37,1 x 11 x 113,2	S - - A/S - Cr -	- 45° - - - 45° - -	9 - 9 - III	A 121 053 04 01 A 115 050 00 27 A 115 050 01 27 A 129 053 00 05 A 129 053 01 05 A 130 053 01 05 A 290 053 01 05	<b>2620</b> <b>261106</b>
Fortsetzung nächste Seite / continued on next page / suite page suivante / continuación página próxima / Продолжение на следующей странице						



					Reference	Item No.		
[50]	Ø 9 mm				A 115 053 00 26	<b>RK-9H</b>		
IN [4]	14,04 x 9 x 55,0	B1			A 130 050 01 24	<b>81-2667</b>		
IN [4]	14,24 x 9 x 55,0	B1			A 130 050 02 24	<b>81-2668</b>		
EX [4]	15,04 x 11 x 45,0	B1			A 108 050 05 24	<b>81-2659</b>		
EX [4]	15,24 x 11 x 45,0	B1			A 108 050 07 24	<b>81-2660</b>		
<b>59</b>		<b>87</b>						
<b>OM 615</b>	<b>962 (ESP)</b>	D	4	1988 cm <sup>3</sup>	2V	83,60 mm		
<b>OM 615</b>	<b>913, 915, 940, 942 - 944, 960 - 961, 963 - 970</b>	D (NA)	4	1988 cm <sup>3</sup>	2V	40-46 kW (54-62 PS)	83,60 mm	
<b>OM 615</b>	<b>935</b>	D	4	2197 cm <sup>3</sup>	2V	44 kW (60 PS) 21:1	92,40 mm	
<b>OM 615</b>	01.1972 → 12.1980	D (NA)	4	2197 cm <sup>3</sup>	2V	40-44 kW (55-60 PS) 21	92,40 mm	
<b>OM 615</b>	<b>910 - 912, 914, 917 - 919, 930, 932, 936 - 939, 941</b>	D (NA)	4	2197 cm <sup>3</sup>	2V	33-49 kW (45-67 PS)	92,40 mm	
<b>OM 621</b>	<b>912 - 913, 915 - 916, 918 - 919, 930 - 932</b>	D (NA)	4	1988 cm <sup>3</sup>	2V	25-40 kW (34-55 PS)	83,60 mm	
IN [2]	39,0 x 10 x 131,5	S - Cr -	-	30°	-	25 -	A 615 053 00 01 A 615 053 01 01 A 615 053 05 01 A 651 053 00 01	<b>2641</b>
EX [2]	33,2 x 10 x 131,0	A/S - Cr -	-	30°	-	25 - III	A 615 053 04 05 A 615 053 07 05	<b>261118</b>
IN [4]	14,00 x 10 x 60,0	G1					A 611 053 15 29 A 616 053 03 29	<b>81-2602</b>
EX [4]	14,00 x 10 x 48,5	G1					A 616 053 03 30 A 621 053 36 30	<b>81-2604</b>
<b>60</b>		<b>87</b>						
<b>OM 601</b>	<b>911 - 912</b>	D (NA)	4	1997 cm <sup>3</sup>	2V	53-55 kW (72-75 PS) 22	84,00 mm	
<b>OM 601</b>	<b>921</b>	D (NA)	4	2197 cm <sup>3</sup>	2V	54 kW (72 PS) 22	92,40 mm	
94 330 6..								
IN [2]	38,0 x 8 x 106,4	S - Cr -	-	45°	-	9 - III	A 601 053 04 01 A 601 053 12 01 A 601 053 15 01 A 601 053 17 01	<b>26024</b>
EX [2]	35,0 x 9 x 106,4	A/S - Cr -	-	45°	VS -	9 - III	A 601 050 02 27 A 601 050 05 27 A 601 050 12 27 A 601 050 21 27 A 601 050 25 27 A 601 050 30 27	<b>26032</b>
[50]	Ø 8 mm						A 102 053 00 26	<b>RK-8H</b>
IN [4]	14,02 x 8 x 39,5	G1 CC					A 601 050 06 24	<b>81-1682</b>
IN [4]	14,20 x 8 x 39,5	G1 CC					A 601 050 07 24	<b>81-1683</b>
IN [4]	14,40 x 8 x 39,5	G1 CC					A 601 050 08 24	<b>81-1684</b>
EX [4]	14,02 x 9 x 37,3	G1 CC					A 601 050 09 24	<b>81-1685</b>
EX [4]	14,20 x 9 x 37,3	G1 CC					A 601 050 10 24	<b>81-1686</b>
IN [1]	40,09 x 33,5 x 7,0	G1 45°					A 601 053 03 31	<b>92-16120</b>
IN [1]	40,58 x 33,5 x 7,3	G1					A 601 053 02 31	<b>92-16121</b>
EX [2]	37,59 x 30,5 x 7,3	G1					A 601 053 02 32	<b>92-16125</b>
EX [1]	37,08 x 30,56 x 7,0	G1 30°					A 601 053 03 32	<b>92-16124</b>
Fortsetzung nächste Seite / continued on next page / suite page suivante / continuación página próxima / Продолжение на следующей странице								

					Reference	Item No.	
					A 601 050 08 01	<b>50 006 282</b> (1)	
	(1) Schalenhartguss/chilled cast iron/pièce moulée trempée en surface/fundición en coquilla/Отливка с отбелсным поверхностным слоем						
	[8]	H 40 x 36 x 36			A 040 507 08 25 A 601 050 00 80 A 601 050 03 25 A 601 050 03 80 A 601 050 04 25 A 601 050 05 25 A 601 050 06 25 A 601 050 07 25 A 601 050 08 25	<b>50 006 456</b>	
<b>61</b>		<b>87</b>					
<b>OM 602</b>	<b>911 - 912, 930 - 931, 938 - 939, 990, 993</b>						
	01.1984 → D (NA) 5 2497 cm <sup>3</sup> 2V 62-93 kW (84-126 PS) 84,00 mm						
<b>OM 602</b>	<b>961 - 962</b>						
	02.1988 → 06.1996 D (A) 5 2497 cm <sup>3</sup> 2V 90-93 kW (122-126 PS) 22 84,00 mm						
90 016 6.., 94 330 6..							
	IN [2]	38,0 x 8 x 106,4	S - Cr -	- 45° - -	9 - III	A 601 053 04 01 A 601 053 12 01 A 601 053 15 01 A 601 053 17 01	<b>26024</b>
	EX [2]	35,0 x 9 x 106,4	A/S - Cr -	- 45° - VS -	9 - III	A 601 050 02 27 A 601 050 05 27 A 601 050 12 27 A 601 050 21 27 A 601 050 25 27 A 601 050 30 27	<b>26032</b>
	[50]	Ø 8 mm				A 102 053 00 26	<b>RK-8H</b>
	IN [4]	14,02 x 8 x 39,5	G1 CC			A 601 050 06 24	<b>81-1682</b>
	IN [4]	14,20 x 8 x 39,5	G1 CC			A 601 050 07 24	<b>81-1683</b>
	IN [4]	14,40 x 8 x 39,5	G1 CC			A 601 050 08 24	<b>81-1684</b>
	EX [4]	14,02 x 9 x 37,3	G1 CC			A 601 050 09 24	<b>81-1685</b>
	EX [4]	14,20 x 9 x 37,3	G1 CC			A 601 050 10 24	<b>81-1686</b>
	IN [1]	40,09 x 33.5 x 7,0	G1 45°			A 601 053 03 31	<b>92-16120</b>
	IN [1]	40,58 x 33.5 x 7,3	G1			A 601 053 02 31	<b>92-16121</b>
	EX [2]	37,59 x 30.5 x 7,3	G1			A 601 053 02 32	<b>92-16125</b>
	EX [1]	37,08 x 30.56 x 7,0	G1 30°			A 601 053 03 32	<b>92-16124</b>
						A 602 050 08 01	<b>50 006 284</b> (1)
	(1) Schalenhartguss/chilled cast iron/pièce moulée trempée en surface/fundición en coquilla/Отливка с отбелсным поверхностным слоем						
	[8]	H 40 x 36 x 36				A 040 507 08 25 A 601 050 00 80 A 601 050 03 25 A 601 050 03 80 A 601 050 04 25 A 601 050 05 25 A 601 050 06 25 A 601 050 07 25 A 601 050 08 25	<b>50 006 456</b>

M

					Reference	Item No.	
<b>62</b>		<b>87</b>					
<b>OM 603</b>	<b>960 - 963</b>	09.1985 →	D (A)	6	2996 cm <sup>3</sup> 2V	100-110 kW (136-148 PS)	84,00 mm
<b>OM 603</b>	<b>912 - 913, 931</b>	12.1984 → 06.1996	D (NA)	6	2996 cm <sup>3</sup> 2V	80-83 kW (109-113 PS) 22	84,00 mm
90 016 6.., 94 330 6..							
	IN [2]	38,0 x 8 x 106,4	S - Cr -	- 45° -	-	9 - III	A 601 053 04 01 A 601 053 12 01 A 601 053 15 01 A 601 053 17 01 <b>26024</b>
	EX [2]	35,0 x 9 x 106,4	A/S - Cr -	- 45° - VS -		9 - III	A 601 050 02 27 A 601 050 05 27 A 601 050 12 27 A 601 050 21 27 A 601 050 25 27 A 601 050 30 27 <b>26032</b>
	[50]	∅ 8 mm					A 102 053 00 26 <b>RK-8H</b>
	IN [4]	14,02 x 8 x 39,5	G1 CC				A 601 050 06 24 <b>81-1682</b>
	IN [4]	14,20 x 8 x 39,5	G1 CC				A 601 050 07 24 <b>81-1683</b>
	IN [4]	14,40 x 8 x 39,5	G1 CC				A 601 050 08 24 <b>81-1684</b>
	EX [4]	14,02 x 9 x 37,3	G1 CC				A 601 050 09 24 <b>81-1685</b>
	EX [4]	14,20 x 9 x 37,3	G1 CC				A 601 050 10 24 <b>81-1686</b>
	IN [1]	40,09 x 33.5 x 7,0	G1 45°				A 601 053 03 31 <b>92-16120</b>
	IN [1]	40,58 x 33.5 x 7,3	G1				A 601 053 02 31 <b>92-16121</b>
	EX [2]	37,59 x 30.5 x 7,3	G1				A 601 053 02 32 <b>92-16125</b>
	EX [1]	37,08 x 30.56 x 7,0	G1 30°				A 601 053 03 32 <b>92-16124</b>
							A 603 050 07 01 <b>50 006 287</b>
	[8]	H 40 x 36 x 36					A 040 507 08 25 A 601 050 00 80 A 601 050 03 25 A 601 050 03 80 A 601 050 04 25 A 601 050 05 25 A 601 050 06 25 A 601 050 07 25 A 601 050 08 25 <b>50 006 456</b>
<b>63</b>		<b>87</b>					
<b>OM 603</b>	<b>950</b>	10.1988 →	D (A)	6	2996 cm <sup>3</sup> 2V	100-105 kW (136-143 PS) 22:1	84,00 mm
90 016 6..							
	IN [2]	38,0 x 8 x 106,4	S - Cr -	- 45° -	-	9 - III	A 601 053 04 01 A 601 053 12 01 A 601 053 15 01 A 601 053 17 01 <b>26024</b>
	EX [2]	35,0 x 9 x 106,4	A/S - Cr -	- 45° - VS -		9 - III	A 601 050 02 27 A 601 050 05 27 A 601 050 12 27 A 601 050 21 27 A 601 050 25 27 A 601 050 30 27 <b>26032</b>
	[50]	∅ 8 mm					A 102 053 00 26 <b>RK-8H</b>
Fortsetzung nächste Seite / continued on next page / suite page suivante / continuación página próxima / Продолжение на следующей странице							

					Reference	Item No.
	IN [4] IN [4] IN [4] EX [4] EX [4]	14,02 x 8 x 39,5 14,20 x 8 x 39,5 14,40 x 8 x 39,5 14,02 x 9 x 37,3 14,20 x 9 x 37,3	G1 CC G1 CC G1 CC G1 CC G1 CC		A 601 050 06 24 A 601 050 07 24 A 601 050 08 24 A 601 050 09 24 A 601 050 10 24	<b>81-1682</b> <b>81-1683</b> <b>81-1684</b> <b>81-1685</b> <b>81-1686</b>
	IN [1] IN [1] EX [2] EX [1]	40,09 x 33.5 x 7,0 40,58 x 33.5 x 7,3 37,59 x 30.5 x 7,3 37,08 x 30.56 x 7,0	G1 45° G1 G1 G1 30°		A 601 053 03 31 A 601 053 02 31 A 601 053 02 32 A 601 053 03 32	<b>92-16120</b> <b>92-16121</b> <b>92-16125</b> <b>92-16124</b>

**64**
**87**
**OM 601**
**913**

 03.1993 → 05.2000 D (NA) 4 1997 cm<sup>3</sup> 2V 55 kW (75 PS) 22 84,00 mm

94 330 6..

	IN [2]  EX [2]	38,0 x 8 x 106,4  35,0 x 9 x 106,4	S - Cr -  A/S - Cr -	- 45° - -  - 45° - VS -	9 - III  9 - III	A 601 053 04 01 A 601 053 12 01 A 601 053 15 01 A 601 053 17 01 A 601 050 02 27 A 601 050 05 27 A 601 050 12 27 A 601 050 21 27 A 601 050 25 27 A 601 050 30 27	<b>26024</b>  <b>26032</b>
	[50]	∅ 8 mm				A 102 053 00 26	<b>RK-8H</b>
	IN [4] IN [4] IN [4] EX [4] EX [4]	14,02 x 8 x 39,5 14,20 x 8 x 39,5 14,40 x 8 x 39,5 14,02 x 9 x 37,3 14,20 x 9 x 37,3	G1 CC G1 CC G1 CC G1 CC G1 CC			A 601 050 06 24 A 601 050 07 24 A 601 050 08 24 A 601 050 09 24 A 601 050 10 24	<b>81-1682</b> <b>81-1683</b> <b>81-1684</b> <b>81-1685</b> <b>81-1686</b>
	IN [1] IN [1] EX [2] EX [1]	40,09 x 33.5 x 7,0 40,58 x 33.5 x 7,3 37,59 x 30.5 x 7,3 37,08 x 30.56 x 7,0	G1 45° G1 G1 G1 30°			A 601 053 03 31 A 601 053 02 31 A 601 053 02 32 A 601 053 03 32	<b>92-16120</b> <b>92-16121</b> <b>92-16125</b> <b>92-16124</b>
	[8]	H 40 x 36 x 36				A 040 507 08 25 A 601 050 00 80 A 601 050 03 25 A 601 050 03 80 A 601 050 04 25 A 601 050 05 25 A 601 050 06 25 A 601 050 07 25 A 601 050 08 25	<b>50 006 456</b>

**65**
**87**
**OM 604**
**915, 917**

 01.1996 → 03.2002 D (NA) 4 1997 cm<sup>3</sup> 4V 65-85 kW (88-116 PS) 22 84,00 mm

**OM 605**
**960, 962**

 10.1995 → 03.2001 D (LA) 5 2497 cm<sup>3</sup> 4V 110 kW (150 PS) 22 84,00 mm

**OM 605**
**910 - 912**

 05.1993 → 05.2000 D (NA) 5 2497 cm<sup>3</sup> 4V 83 kW (113 PS) 22 84,00 mm

**OM 606**
**961**

 05.1996 → 10.1998 D (LA) 6 2996 cm<sup>3</sup> 4V 130 kW (177 PS) 22 84,00 mm

**OM 606**
**910, 912**

 06.1993 → 06.1997 D (NA) 6 2996 cm<sup>3</sup> 4V 100 kW (136 PS) 22 84,00 mm

**OM 606**
**962, 964**

 09.1996 → 07.2000 D (A) 6 2996 cm<sup>3</sup> 4V 130 kW (177 PS) 22 84,00 mm

94 819 7.., 94 820 7..

Fortsetzung nächste Seite / continued on next page / suite page suivante / continuación página próxima / Продолжение на следующей странице

					Reference	Item No.
IN [2]	29,0 x 6 x 105,4	S - Cr -	- 45° - -	22 - III	A 606 053 05 01 A 606 053 06 01 A 606 053 07 01	<b>26264</b>
IN [2]	29,0 x 6 x 105,4	S - Ni -	- 45° - -	9 -	A 606 053 11 01	<b>26045</b>
EX [2]	26,0 x 6 x 105,7	A - Cr -	- 45° - -	9 -	A 606 053 06 05 A 606 053 07 05	<b>26046</b>
EX [2]	26,0 x 7 x 105,5	A/S - Cr -	- 45° - -	9 - III	A 606 050 11 27 A 606 050 14 27	<b>26047</b>
[50]	∅ 6 mm				A 000 053 10 26	<b>LK-6H</b>
[50]	∅ 7 mm					<b>LK-7H</b>
IN [4]	12,50 x 6 x 37,5	G1			A 606 053 12 29	<b>81-26175</b>
EX [4]	12,50 x 7 x 37,5	G2			A 606 053 02 30	<b>81-26178</b>

## 66

<b>M 116</b>	<b>961 (SUI), 961 (USA)</b>	B	8	3818 cm <sup>3</sup>	2V	120-145 kW	(163-197 PS)	8,3:1	78,90 mm
<b>M 116</b>	<b>962 - 963</b>	B (NA)	8	3839 cm <sup>3</sup>	2V	116-150 kW	(158-204 PS)	9,4	78,90 mm
	09.1980 → 03.1986								

IN [2]	39,1 x 9 x 117,0	S - -	- 45° - VS -	9 - III	A 116 050 04 26	<b>26052</b>
EX [2]	37,1 x 9 x 118,2	A/S - Cr -	- 45° - -	9 - III	A 116 050 00 27	<b>261109</b>
[50]	∅ 9 mm				A 115 053 00 26	<b>RK-9H</b>
IN [6]	14,24 x 9 x 47,5	B1			A 116 050 49 24	<b>81-26119</b>
IN [4]	14,04 x 9 x 47,5	B1			A 116 050 47 24	<b>81-26118</b>
IN [4]	14,04 x 9 x 47,5	B1			A 116 050 36 24	<b>81-2685</b>
EX [4]	15,04 x 9 x 50,5	B1			A 116 050 53 24	<b>81-26121</b>
EX [4]	15,24 x 9 x 50,5	B1			A 116 050 55 24	<b>81-26122</b>

## 67

<b>M 272</b>	<b>911, 920 - 922</b>	B (NA)	6	2496 cm <sup>3</sup>	4V	150 kW	(204 PS)	11,2	68,40 mm
<b>M 272</b>	<b>940 - 949, 952</b>	B (NA)	6	2996 cm <sup>3</sup>	4V	161-180 kW	(219-245 PS)		82,10 mm
	01.2005 → 08.2014								
	01.2005 → 12.2015								

IN [2]	37,0 x 6 x 109,4	S - Cr -	- 45° - -	22 - III	A 272 053 02 01 A 272 053 08 01	<b>261130</b>
EX [2]	28,0 x 6 x 107,4	A/S - Cr -	- 45° - VS -	22 - III	A 272 050 02 27 A 272 050 09 27	<b>261131</b>
[8]	H 12 x 34,6 x 34,6				A 160 050 01 80 A 642 050 00 80 A 642 050 01 80	<b>50 006 432</b>

## 68

<b>OM 611</b>	<b>961 - 962</b>	D (LA)	4	2148 cm <sup>3</sup>	4V	75-105 kW	(102-143 PS)	18	88,30 mm
<b>OM 611</b>	<b>960</b>	D (LA)	4	2151 cm <sup>3</sup>	4V	75-92 kW	(102-125 PS)	19	88,40 mm
<b>OM 611A (60 KW CDI)</b>		D (A)	4	2148 cm <sup>3</sup>	4V	60 kW	(82 PS)	19:1	88,40 mm
<b>OM 611LA (75 KW CDI)</b>		D (A)	4	2148 cm <sup>3</sup>	4V	75 kW	(102 PS)	19:1	88,40 mm
	06.1998 → 08.2007								
	09.1997 → 03.2001								
	03.1999 → 07.2003								
	03.1999 → 07.2003								

IN [2]	30,1 x 7 x 104,0	S - Ni -	- 45° - -	1 -	A 611 053 01 01 A 611 053 04 01	<b>261102</b>
EX [2]	28,4 x 7 x 104,4	A/S - Cr -	- 45° - -	1 - III	A 611 050 01 27 A 611 053 01 05	<b>261103</b>

Fortsetzung nächste Seite / continued on next page / suite page suivante / continuación página próxima / Продолжение на следующей странице



					Reference	Item No.	
	IN/EX [4] 12,57 x 7 x 37,5 IN/EX [4] 12,76 x 7 x 37,5	G2 G2			A 611 053 03 29	<b>81-26182</b> <b>81-26185</b>	
	423 mm  ES  (1) Schalenhartguss/chilled cast iron/pièce moulée trempée en surface/fundición en coquilla/Отливка с отбеленным поверхностным слоем				A 611 050 01 01 A 611 050 18 01 A 611 050 00 01 A 611 050 08 01	<b>20 1003 61100</b>  <b>50 006 375</b> (1)	
	[8] H 33 x 24,2 x 24,2				A 611 050 00 25 A 611 050 02 25	<b>50 006 424</b>	
<b>69</b>	<b>88</b>						
<b>OM 611</b>	<b>980</b> 03.1999 → 07.2003 D (A) 4 2148 cm <sup>3</sup> 4V 60-90 kW (82-122 PS) 18 88,30 mm						
<b>OM 611 Euro 3</b>	<b>981, 987</b> 04.2000 → 05.2006 D (A) 4 2148 cm <sup>3</sup> 4V 60-95 kW (82-129 PS) 18 88,30 mm						
<b>OM 611 Euro 3</b>	<b>983</b> D (A) 4 2151 cm <sup>3</sup> 4V 80-95 kW (109-129 PS) 18:1 88,40 mm						
41 014 6.., 97 409 6..							
	IN [2] 30,1 x 7 x 104,0 EX [2] 28,4 x 7 x 104,4	S - Ni - A/S - Cr -	- 45° - - 45° -	- -	1 - 1 - III	A 611 053 01 01 A 611 053 04 01 A 611 050 01 27 A 611 053 01 05	<b>261102</b>  <b>261103</b>
	IN/EX [4] 12,57 x 7 x 37,5 IN/EX [4] 12,76 x 7 x 37,5	G2 G2			A 611 053 03 29	<b>81-26182</b> <b>81-26185</b>	
	423 mm  ES  (1) Schalenhartguss/chilled cast iron/pièce moulée trempée en surface/fundición en coquilla/Отливка с отбеленным поверхностным слоем				A 611 050 01 01 A 611 050 18 01 A 611 050 00 01 A 611 050 08 01	<b>20 1003 61100</b>  <b>50 006 375</b> (1)	
	[8] H 33 x 24,2 x 24,2				A 611 050 00 25 A 611 050 02 25	<b>50 006 424</b>	
	- - G - S -   - V - G - S -	- SB -  - SB -				A 611 010 23 20 A 611 010 44 20 A 611 010 66 20 A 611 010 67 20	<b>50 003 119</b> (2)
					20 Nm 60 Nm 90° 90°  partially assembled	A 611 010 23 20 A 611 010 44 20 A 611 010 54 20 A 611 010 66 20 A 611 010 67 20 A 611 010 68 20	<b>50 003 419</b> (2)
	(2) ACHTUNG: Bitte Beiblatt zur Wasserbohrung Ø 8 mm beachten! (SI0013) ATTENTION: Check information to water channel hole Ø 8 mm! (SI0013) ATTENTION: Vérifier l'information de la passage d'eau Ø 8 mm! (SI0013) ATENCIÓN: Compruebe la información el paso de agua Ø 8 mm! (SI0013) „ВНИМАНИЕ: Пожалуйста, учтите листок к водяному сверлению Ø 8 мм!“ (SI0013)						

M

					Reference	Item No.	
<b>70</b>		<b>88</b>					
<b>OM 612</b>	<b>961 - 963, 965 - 967</b>	07.1999 →	D (LA) 5	2685 cm <sup>3</sup> 4V	115-125 kW (156-170 PS)	88,30 mm	
<b>OM 612 Euro 3</b>	<b>983</b>	05.2003 →	D (A) 5	2685 cm <sup>3</sup> 4V	115 kW (156 PS) 18:1	88,30 mm	
<b>OM 612</b>	<b>990</b>	09.2002 → 05.2008	D (LA) 5	2950 cm <sup>3</sup> 4V	170 kW (231 PS) 16,5	97,00 mm	
<b>OM 613</b>	<b>960 - 961</b>	07.1999 → 03.2003	D (LA) 6	4V	145 kW (197 PS) 18	88,30 mm	
41 014 6..., 97 409 6..							
	IN [2]	30,1 x 7 x 104,0	S - Ni -	- 45° - -	1 -	A 611 053 01 01 A 611 053 04 01 A 611 050 01 27 A 611 053 01 05	<b>261102</b>
	EX [2]	28,4 x 7 x 104,4	A/S - Cr -	- 45° - -	1 - III		<b>261103</b>
	IN/EX [4]	12,57 x 7 x 37,5	G2			A 611 053 03 29	<b>81-26182</b>
	IN/EX [4]	12,76 x 7 x 37,5	G2				<b>81-26185</b>
	[8]	H 33 x 24,2 x 24,2				A 611 050 00 25 A 611 050 02 25	<b>50 006 424</b>
<b>71</b>		<b>88</b>					
<b>OM 612 Euro 3</b>	<b>981</b>	04.2000 →	D (A) 5	2685 cm <sup>3</sup> 4V	110-115 kW (150-156 PS) 18	88,30 mm	
41 014 6..., 97 409 6..							
	IN [2]	30,1 x 7 x 104,0	S - Ni -	- 45° - -	1 -	A 611 053 01 01 A 611 053 04 01 A 611 050 01 27 A 611 053 01 05	<b>261102</b>
	EX [2]	28,4 x 7 x 104,4	A/S - Cr -	- 45° - -	1 - III		<b>261103</b>
	IN/EX [4]	12,57 x 7 x 37,5	G2			A 611 053 03 29	<b>81-26182</b>
	IN/EX [4]	12,76 x 7 x 37,5	G2				<b>81-26185</b>
	[8]	H 33 x 24,2 x 24,2				A 611 050 00 25 A 611 050 02 25	<b>50 006 424</b>
	- - G - S -		- SB - -			A 612 010 10 20 A 612 010 14 20 A 612 010 20 20 A 612 010 32 20 A 612 010 35 20	<b>50 003 125</b> (1)
	- V - G - S -		- SB - -				<b>50 003 425</b> (1)
<p>partially assembled</p>							
<p>(1) Ansaugseite-Wasserstopfen-montiert-Ø 19 mm          Manifoldside-water plug-fitted-Ø 19 mm          Còdè d'aspiración-bouchon d'aquacole-monté-Ø 19 mm          Lado de aspiración-tarón de agua-montado-Ø 19 mm          Сторона впуска-водяная пробка-смонтирована-Ø 19 мм</p>							

					Reference	Item No.
<b>72</b>		<b>88</b>				
<b>OM 646</b>	<b>701</b>					
	09.2013 →	D (A)	4	2148 cm <sup>3</sup>	4V 80-100 kW (109-136 PS)	88,30 mm
<b>OM 646</b>	<b>811 - 812, 820 - 821, 980 - 981, 984 - 985, 989 - 990, 992</b>					
	03.2003 →	D (LA)	4	2148 cm <sup>3</sup>	4V 65-125 kW (88-170 PS)	88,30 mm
<b>OM 646 Euro 4</b>	<b>986</b>					
	06.2006 →	D (LA)	4	2148 cm <sup>3</sup>	4V 95-110 kW (129-150 PS) 18	88,30 mm
<b>OM 647</b>	<b>961, 981</b>					
	04.2000 → 07.2009	D (LA)	5	2685 cm <sup>3</sup>	4V 60-130 kW (82-177 PS)	88,30 mm
<b>OM 648</b>	<b>960 - 961</b>					
	09.2002 → 07.2009	D (LA)	6	3222 cm <sup>3</sup>	4V 130-150 kW (177-204 PS)	88,30 mm
41 882 6..., 97 482 6..						
	IN [2]	28,7 x 7 x 104,1	S - Ni -	- 45° - -	1 -	A 628 053 00 01 A 646 053 00 01 <b>261124</b> (1)
	EX [2]	26,2 x 7 x 104,5	RA/S- Ni -	- 45° - -	1 -	A 628 053 00 05 <b>261125</b> (1)
	(1)	Kegelstückfixierung/cotter fixation/fijación de chavetas/fijación de chavetas/Крепление конического сухаря Ø 6 mm				
	[50]	Ø 6 mm				A 000 053 10 26 <b>LK-6H</b>
	IN/EX [4]	12,57 x 7 x 37,5	G2			A 611 053 03 29 <b>81-26182</b>
	IN/EX [4]	12,76 x 7 x 37,5	G2			<b>81-26185</b>
	[8]	H 33 x 24,2 x 24,2				A 611 050 00 25 A 611 050 02 25 <b>50 006 424</b>
<b>73</b>		<b>88</b>				
<b>OM 646</b>	<b>951</b>					
	07.2002 → 12.2008	D (NA)	4	2148 cm <sup>3</sup>	4V 75-90 kW (102-122 PS) 18	88,30 mm
<b>OM 646</b>	<b>961 - 963</b>					
	05.2000 → 06.2011	D (LA)	4	2148 cm <sup>3</sup>	4V 75-110 kW (102-150 PS) 18	88,30 mm
97 482 6..						
	IN [2]	28,7 x 7 x 104,1	S - Ni -	- 45° - -	1 -	A 628 053 00 01 A 646 053 00 01 <b>261124</b> (1)
	EX [2]	26,2 x 7 x 104,5	RA/S- Ni -	- 45° - -	1 -	A 628 053 00 05 <b>261125</b> (1)
	(1)	Kegelstückfixierung/cotter fixation/fijación de chavetas/fijación de chavetas/Крепление конического сухаря Ø 6 mm				
	[50]	Ø 6 mm				A 000 053 10 26 <b>LK-6H</b>
	IN/EX [4]	12,57 x 7 x 37,5	G2			A 611 053 03 29 <b>81-26182</b>
	IN/EX [4]	12,76 x 7 x 37,5	G2			<b>81-26185</b>
		423 mm				A 611 050 01 01 A 611 050 18 01 <b>20 1003 61100</b>
	[8]	H 33 x 24,2 x 24,2				A 611 050 00 25 A 611 050 02 25 <b>50 006 424</b>
		- - G - S -	- SB - -			A 611 010 50 20 A 646 010 06 20 A 646 010 10 20 A 646 010 14 20 <b>50 003 122</b> (2)
					20 Nm 60 Nm 90° 90°	
Fortsetzung nächste Seite / continued on next page / suite page suivante / continuación página próxima / Продолжение на следующей странице						

					Reference	Item No.
(2)	ACHTUNG: Bitte Beiblatt zur Wasserbohrung $\varnothing$ 8 mm beachten! (SI0013) ATTENTION: Check information to water channel hole $\varnothing$ 8 mm! (SI0013) ATTENTION: Vérifier l'information de la passage d'eau $\varnothing$ 8 mm! (SI0013) ATENCIÓN: Compruebe la información el paso de agua $\varnothing$ 8 mm! (SI0013) „ВНИМАНИЕ: Пожалуйста, учтите листок к водяному сверлению $\varnothing$ 8 мм!“ (SI0013)					

## 74 88

<b>OM 646</b>	<b>983</b>	09.2003 →	D (LA)	4	2148 cm <sup>3</sup>	4V	65-80 kW	(88-109 PS)	18,1	88,30 mm
<b>OM 646 Euro 4</b>	<b>982</b>	09.2003 →	D (LA)	4	2148 cm <sup>3</sup>	4V	80-110 kW	(109-150 PS)	18	88,30 mm

97 482 6..

	IN [2]	28,7 x 7 x 104,1	S - Ni -	- 45° -	-	1 -	A 628 053 00 01 A 646 053 00 01	<b>261124</b>	(1)	
	EX [2]	26,2 x 7 x 104,5	RA/S- Ni -	- 45° -	-	1 -	A 628 053 00 05	<b>261125</b>	(1)	
	(1)	Kegelstückfixierung/cotter fixation/fijación de chavetas/fijación de chavetas/Крепление конического сухаря $\varnothing$ 6 mm								
	[50]	$\varnothing$ 6 mm					A 000 053 10 26	<b>LK-6H</b>		
	IN/EX [4]	12,57 x 7 x 37,5	G2				A 611 053 03 29	<b>81-26182</b>		
	IN/EX [4]	12,76 x 7 x 37,5	G2					<b>81-26185</b>		
		423 mm					A 611 050 01 01 A 611 050 18 01	<b>20 1003 61100</b>		
	[8]	H 33 x 24,2 x 24,2					A 611 050 00 25 A 611 050 02 25	<b>50 006 424</b>		

## 75 88

<b>OM 646</b>	<b>966</b>	01.2005 → 05.2009	D (LA)	4	2148 cm <sup>3</sup>	4V	100-110 kW	(136-150 PS)	18	88,30 mm
---------------	------------	-------------------	--------	---	----------------------	----	------------	--------------	----	----------

97 482 6..

	IN [2]	28,7 x 7 x 104,1	S - Ni -	- 45° -	-	1 -	A 628 053 00 01 A 646 053 00 01	<b>261124</b>	(1)	
	EX [2]	26,2 x 7 x 104,5	RA/S- Ni -	- 45° -	-	1 -	A 628 053 00 05	<b>261125</b>	(1)	
	(1)	Kegelstückfixierung/cotter fixation/fijación de chavetas/fijación de chavetas/Крепление конического сухаря $\varnothing$ 6 mm								
	[50]	$\varnothing$ 6 mm					A 000 053 10 26	<b>LK-6H</b>		
	IN/EX [4]	12,57 x 7 x 37,5	G2				A 611 053 03 29	<b>81-26182</b>		
	IN/EX [4]	12,76 x 7 x 37,5	G2					<b>81-26185</b>		
	[8]	H 33 x 24,2 x 24,2					A 611 050 00 25 A 611 050 02 25	<b>50 006 424</b>		
		- - G - S -	- SB -	-			A 611 010 50 20 A 646 010 06 20 A 646 010 10 20 A 646 010 14 20	<b>50 003 122</b>	(2)	
							20 Nm 60 Nm 90° 90°			
	(2)	ACHTUNG: Bitte Beiblatt zur Wasserbohrung $\varnothing$ 8 mm beachten! (SI0013) ATTENTION: Check information to water channel hole $\varnothing$ 8 mm! (SI0013) ATTENTION: Vérifier l'information de la passage d'eau $\varnothing$ 8 mm! (SI0013) ATENCIÓN: Compruebe la información el paso de agua $\varnothing$ 8 mm! (SI0013) „ВНИМАНИЕ: Пожалуйста, учтите листок к водяному сверлению $\varnothing$ 8 мм!“ (SI0013)								

					Reference	Item No.		
<b>76</b>	<b>88,5</b>							
<b>M 103</b>	<b>980 - 985, 987</b>							
	01.1985 → 09.1997	B (NA)	6	2960 cm <sup>3</sup>	2V	125-140 kW (170-190 PS)	80,25 mm	
	IN [2]	43,0 x 8 x 110,2	S - Cr -	- 45° -	-	1 - III	A 103 053 04 01 A 103 053 13 01 A 103 053 20 01	<b>26109</b>
	EX [2]	39,0 x 9 x 110,9	A/S - Cr -	- 45° -	VS -	1 - III	A 103 050 05 27 A 103 050 17 27	<b>261113</b> (1)
	(1)	Kegelstückfixierung/cotter fixation/fixation de clavettes/fijación de chavetas/Крепление конического сухаря Ø 8 mm						
	[50]	Ø 8 mm					A 102 053 00 26	<b>RK-8H</b>
	IN [6]	14,00 x 8 x 42,0	B1				A 103 050 22 24	<b>81-26151</b>
	EX [6]	14,00 x 9 x 48,0	B1				A 103 050 27 24	<b>81-26154</b>
							A 103 050 64 01	<b>50 006 223</b> (2)
	(2)	Schalenhartguss/chilled cast iron/pièce moulée trempée en surface/fundición en coquilla/Отливка с отбеленным поверхностным слоем						
	[8]	H 14 x 30					A 103 050 00 80	<b>50 006 454</b>
<b>77</b>	<b>88,5</b>							
<b>M 104</b>	<b>980 - 981</b>							
	09.1988 → 07.1993	B (NA)	6	2960 cm <sup>3</sup>	4V	162-170 kW (220-231 PS)	10 80,20 mm (1)	
	(1)	with or without KAT						
	IN [2]	35,0 x 7 x 101,5	S - Cr -	- 45° -	-	22 - III	A 111 053 01 01 A 111 053 02 01	<b>26208</b>
	IN [2]	35,0 x 7 x 101,5	S - Ni -	- 45° -	-	9 -	A 104 053 12 01 A 104 053 14 01 A 111 053 11 01 A 111 053 21 01 A 111 053 23 01 A 111 053 24 01	<b>26048</b>
	IN [2]	35,0 x 8 x 101,5	S - Cr -	- 45° -	-	9 - III	A 104 053 08 01 A 104 053 10 01	<b>26139</b>
	EX [2]	31,0 x 7 x 103,5	A/S - Cr -	- 45° -	VS -	22 - III	A 111 050 05 27	<b>261114</b>
	[50]	Ø 7 mm						<b>MK-7H</b>
	[50]	Ø 7 mm						<b>RK-7H</b>
	[50]	Ø 8 mm						<b>RK-8</b>
	[50]	Ø 8 mm					A 102 053 00 26	<b>RK-8H</b>
	IN/EX [4]	12,56 x 7.02 x 37,5	G1				A 111 053 10 29	<b>81-26172</b>
	IN/EX [4]	12,70 x 7.02 x 37,5	G1				A 111 053 11 29	<b>81-26173</b>
	IN [6]	13,50 x 7 x 35,5	B1				A 104 050 52 24	<b>81-26163</b>
	EX [6]	13,50 x 8 x 38,0	B1				A 104 050 47 24	<b>81-26166</b>
		ES					A 104 050 74 01	<b>50 006 226</b> (2)
	(2)	Schalenhartguss/chilled cast iron/pièce moulée trempée en surface/fundición en coquilla/Отливка с отбеленным поверхностным слоем						
	[8]	H 35 x 24 x 24					A 104 050 12 25	<b>50 006 421</b>

**M**



					Reference	Item No.		
<b>78</b>		<b>89</b>						
<b>M 102</b>	<b>939</b>							
	06.1980 → 11.1985	B (NA)	4	1997 cm <sup>3</sup>	2V	74-80 kW (100-109 PS) 8	80,25 mm	
<b>M 102</b>	<b>920, 961</b>							
	06.1980 → 06.1993	B (NA)	4		2V	74-93 kW (100-126 PS)	80,30 mm	
93 677 6..								
	IN [2]	43,0 x 8 x 114,9	S - Cr -	- 45° -	-	1 - III	A 102 053 13 01 A 102 053 16 01 A 102 053 18 01	<b>26160</b>
	IN [2]	46,0 x 8 x 114,9	S - Cr -	- 45° -	-	1 - III	A 102 053 15 01 A 102 053 17 01	<b>26135</b>
	EX [2]	39,0 x 9 x 115,9	A/S - Cr -	- 45° -	-	1 - III		<b>261107</b> (1)
	(1) IAM specification / Kegelstückfixierung/cotter fixation/fixation de clavettes/fijación de chavetas/ Крепление конического сухаря Ø 8 mm							
	[50]	Ø 8 mm					A 102 053 00 26	<b>RK-8H</b>
	IN [4]	14,03 x 8 x 46,0	B1				A 102 050 09 24 A 102 050 17 24	<b>81-2631</b>
	IN [4]	14,04 x 8 x 46,0	B1				A 102 050 89 24	<b>81-26145</b>
	IN [4]	14,23 x 8 x 46,0	B1				A 102 050 10 24	<b>81-2632</b>
	EX [4]	14,03 x 9 x 51,0	B1				A 102 050 12 24 A 102 050 18 24	<b>81-2634</b>
	EX [4]	14,04 x 9 x 51,0	B1				A 102 050 05 62	<b>81-26148</b>
	EX [4]	14,23 x 9 x 51,0	B1				A 102 050 04 62 A 102 050 13 24	<b>81-2635</b>
							A 102 050 02 01	<b>50 006 212</b> (2)
	(2) Schalenhartguss/chilled cast iron/pièce moulée trempée en surface/fundición en coquilla/Отливка с отбеленным поверхностным слоем							
<b>79</b>		<b>89</b>						
<b>M 102</b>	<b>910, 919</b>							
	04.1990 →	B (NA)	4	1797 cm <sup>3</sup>	2V	77-80 kW (105-109 PS)	72,20 mm	
<b>M 102</b>	<b>963</b>							
	09.1988 → 08.1993	B (NA)	4	1996 cm <sup>3</sup>	2V	87-90 kW (118-122 PS) 9,1	80,20 mm	
<b>M 102</b>	<b>922, 924, 965</b>							
	08.1983 → 07.1993	B (NA)	4	1996 cm <sup>3</sup>	2V	75-85 kW (102-116 PS)	80,25 mm	
<b>M 102</b>	<b>962, 964</b>							
	07.1982 → 08.1993	B (NA)	4		2V	80-90 kW (109-122 PS) 9,1	80,30 mm	
93 677 6..								
	IN [2]	43,0 x 8 x 114,9	S - Cr -	- 45° -	-	1 - III	A 102 053 13 01 A 102 053 16 01 A 102 053 18 01	<b>26160</b>
	EX [2]	39,0 x 9 x 115,9	A/S - Cr -	- 45° -	-	1 - III		<b>261107</b> (1)
	(1) IAM specification / Kegelstückfixierung/cotter fixation/fixation de clavettes/fijación de chavetas/ Крепление конического сухаря Ø 8 mm							
	[50]	Ø 8 mm					A 102 053 00 26	<b>RK-8H</b>
	IN [4]	14,03 x 8 x 46,0	B1				A 102 050 09 24 A 102 050 17 24	<b>81-2631</b>
	IN [4]	14,04 x 8 x 46,0	B1				A 102 050 89 24	<b>81-26145</b>
	IN [4]	14,23 x 8 x 46,0	B1				A 102 050 10 24	<b>81-2632</b>
	EX [4]	14,03 x 9 x 51,0	B1				A 102 050 12 24 A 102 050 18 24	<b>81-2634</b>
	EX [4]	14,04 x 9 x 51,0	B1				A 102 050 05 62	<b>81-26148</b>
	EX [4]	14,23 x 9 x 51,0	B1				A 102 050 04 62 A 102 050 13 24	<b>81-2635</b>
Fortsetzung nächste Seite / continued on next page / suite page suivante / continuación página próxima / Продолжение на следующей странице								

					Reference	Item No.	
					A 102 050 55 01	<b>50 006 222</b> (2)	
	(2) Schalenhartguss/chilled cast iron/pièce moulée trempée en surface/fundición en coquilla/Отливка с отбеленным поверхностным слоем						
	[8]	H 14 x 30			A 103 050 00 80	<b>50 006 454</b>	
<b>80</b>		<b>89</b>					
<b>M 102</b>	<b>938</b>		B (NA) 4	1997 cm <sup>3</sup> 2V	63 kW (86 PS) 8:1	80,25 mm	
<b>M 102</b>	<b>921</b>	10.1982 → 10.1984	B (NA) 4	1996 cm <sup>3</sup> 2V	63-77 kW (86-105 PS) 9:1	80,30 mm	
	IN [2]	43,0 x 8 x 114,9	S - Cr -	- 45° - -	1 - III	A 102 053 13 01 A 102 053 16 01 A 102 053 18 01	<b>26160</b>
	EX [2]	39,0 x 9 x 115,9	A/S - Cr -	- 45° - -	1 - III		<b>261107</b> (1)
	(1) IAM specification / Kegelstückfixierung/cotter fixation/fixation de clavettes/fijación de chavetas/ Крепление конического сухаря Ø 8 mm						
	[50]	Ø 8 mm				A 102 053 00 26	<b>RK-8H</b>
	IN [4]	14,03 x 8 x 46,0	B1			A 102 050 09 24 A 102 050 17 24	<b>81-2631</b>
	IN [4]	14,04 x 8 x 46,0	B1			A 102 050 89 24	<b>81-26145</b>
	IN [4]	14,23 x 8 x 46,0	B1			A 102 050 10 24	<b>81-2632</b>
	EX [4]	14,03 x 9 x 51,0	B1			A 102 050 12 24 A 102 050 18 24	<b>81-2634</b>
	EX [4]	14,04 x 9 x 51,0	B1			A 102 050 05 62	<b>81-26148</b>
	EX [4]	14,23 x 9 x 51,0	B1			A 102 050 04 62 A 102 050 13 24	<b>81-2635</b>
<b>81</b>		<b>89</b>					
<b>M 120</b>	<b>980 - 983</b>		B (NA) 12	5987 cm <sup>3</sup> 4V	270-300 kW (381-408 PS)	80,20 mm	
	92 221 6..						
	IN [2]	35,0 x 7 x 101,5	S - Cr -	- 45° - -	22 - III	A 111 053 01 01 A 111 053 02 01	<b>26208</b>
	IN [2]	35,0 x 7 x 101,5	S - Ni -	- 45° - -	9 -	A 104 053 12 01 A 104 053 14 01 A 111 053 11 01 A 111 053 21 01 A 111 053 23 01 A 111 053 24 01	<b>26048</b>
	EX [2]	31,0 x 7 x 103,5	A/S - Cr -	- 45° - VS -	22 - III	A 111 050 05 27	<b>261114</b>
	EX [2]	31,0 x 7 x 103,5	RA - Ni -	- 45° - -	9 -	A 111 050 12 27	<b>260490</b>
	[50]	Ø 7 mm				A 102 053 02 26	<b>MK-7H</b>
	[50]	Ø 7 mm					<b>RK-7</b>
	[50]	Ø 7 mm					<b>RK-7H</b>
	IN/EX [4]	12,56 x 7.02 x 37,5	G1			A 111 053 10 29	<b>81-26172</b>
	IN/EX [4]	12,70 x 7.02 x 37,5	G1			A 111 053 11 29	<b>81-26173</b>
	IN [6]	13,50 x 7 x 35,5	B1			A 104 050 52 24	<b>81-26163</b>
	[8]	H 35 x 24 x 24				A 104 050 12 25	<b>50 006 421</b>

M

					Reference	Item No.	
<b>82</b>	<b>89</b>	<b>OM 602 940 - 942, 946 - 948, 991, 994</b> D (NA) 5 2874 cm <sup>3</sup> 2V 65-72 kW (88-98 PS) 92,40 mm					
<b>OM 602</b>	<b>900/-000</b> 07.1989→	D	5	2874 cm <sup>3</sup>	2V	65-72 kW (88-98 PS)	92,40 mm
91 372 6..., 94 675 6..							
	IN [2]	38,0 x 8 x 106,4	S - Cr -	- 45° -	-	9 - III	A 601 053 04 01 A 601 053 12 01 A 601 053 15 01 A 601 053 17 01 <b>26024</b>
	EX [2]	35,0 x 9 x 106,4	A/S - Cr -	- 45° - VS -		9 - III	A 601 050 02 27 A 601 050 05 27 A 601 050 12 27 A 601 050 21 27 A 601 050 25 27 A 601 050 30 27 <b>26032</b>
	[50]	Ø 8 mm					A 102 053 00 26 <b>RK-8H</b>
	IN [4]	14,02 x 8 x 39,5	G1 CC				A 601 050 06 24 <b>81-1682</b>
	IN [4]	14,20 x 8 x 39,5	G1 CC				A 601 050 07 24 <b>81-1683</b>
	IN [4]	14,40 x 8 x 39,5	G1 CC				A 601 050 08 24 <b>81-1684</b>
	EX [4]	14,02 x 9 x 37,3	G1 CC				A 601 050 09 24 <b>81-1685</b>
	EX [4]	14,20 x 9 x 37,3	G1 CC				A 601 050 10 24 <b>81-1686</b>
	IN [1]	40,09 x 33.5 x 7,0	G1 45°				A 601 053 03 31 <b>92-16120</b>
	IN [1]	40,58 x 33.5 x 7,3	G1				A 601 053 02 31 <b>92-16121</b>
	EX [2]	37,59 x 30.5 x 7,3	G1				A 601 053 02 32 <b>92-16125</b>
	EX [1]	37,08 x 30.56 x 7,0	G1 30°				A 601 053 03 32 <b>92-16124</b>
							A 602 050 08 01 <b>50 006 284</b> (1)
	(1) Schalenhartguss/chilled cast iron/pièce moulée trempée en surface/fundición en coquilla/Отливка с отбелнным поверхностным слоем						
	[8]	H 40 x 36 x 36					A 040 507 08 25 A 601 050 00 80 A 601 050 03 25 A 601 050 03 80 A 601 050 04 25 A 601 050 05 25 A 601 050 06 25 A 601 050 07 25 A 601 050 08 25 <b>50 006 456</b>
<b>83</b>	<b>89</b>	<b>OM 601 Euro 2 900</b> 07.1989→ D (NA) 4 2300 cm <sup>3</sup> 2V 62 kW (85 PS) 92,40 mm					
<b>OM 601</b>	<b>940 - 943</b> 10.1988→05.2006	D (NA)	4	2300 cm <sup>3</sup>	2V	62 kW (85 PS)	92,40 mm
91 372 6..., 94 675 6..							
	IN [2]	38,0 x 8 x 106,4	S - Cr -	- 45° -	-	9 - III	A 601 053 04 01 A 601 053 12 01 A 601 053 15 01 A 601 053 17 01 <b>26024</b>
	EX [2]	35,0 x 9 x 106,4	A/S - Cr -	- 45° - VS -		9 - III	A 601 050 02 27 A 601 050 05 27 A 601 050 12 27 A 601 050 21 27 A 601 050 25 27 A 601 050 30 27 <b>26032</b>
Fortsetzung nächste Seite / continued on next page / suite page suivante / continuación página próxima / Продолжение на следующей странице							

					Reference	Item No.
[50]	Ø 8 mm				A 102 053 00 26	<b>RK-8H</b>
IN [4]	14,02 x 8 x 39,5	G1 CC			A 601 050 06 24	<b>81-1682</b>
IN [4]	14,20 x 8 x 39,5	G1 CC			A 601 050 07 24	<b>81-1683</b>
IN [4]	14,40 x 8 x 39,5	G1 CC			A 601 050 08 24	<b>81-1684</b>
EX [4]	14,02 x 9 x 37,3	G1 CC			A 601 050 09 24	<b>81-1685</b>
EX [4]	14,20 x 9 x 37,3	G1 CC			A 601 050 10 24	<b>81-1686</b>
IN [1]	40,09 x 33.5 x 7,0	G1 45°			A 601 053 03 31	<b>92-16120</b>
IN [1]	40,58 x 33.5 x 7,3	G1			A 601 053 02 31	<b>92-16121</b>
EX [2]	37,59 x 30.5 x 7,3	G1			A 601 053 02 32	<b>92-16125</b>
EX [1]	37,08 x 30.56 x 7,0	G1 30°			A 601 053 03 32	<b>92-16124</b>
					A 601 050 08 01	<b>50 006 282</b> (1)
	(1) Schalenhartguss/chilled cast iron/pièce moulée trempée en surface/fundición en coquilla/Отливка с отбеленным поверхностным слоем					
[8]	H 40 x 36 x 36				A 040 507 08 25 A 601 050 00 80 A 601 050 03 25 A 601 050 03 80 A 601 050 04 25 A 601 050 05 25 A 601 050 06 25 A 601 050 07 25 A 601 050 08 25	<b>50 006 456</b>

<b>84</b>		<b>89</b>
<b>OM 603</b>	<b>970 - 972</b>	
	03.1990 → 08.1999	D (A) 6 3449 cm <sup>3</sup> 2V 100-110 kW (136-150 PS) 92,40 mm

IN [2]	38,0 x 8 x 106,4	S - Cr -	- 45° - -	9 - III	A 601 053 04 01 A 601 053 12 01 A 601 053 15 01 A 601 053 17 01	<b>26024</b>
EX [2]	35,0 x 9 x 106,4	A/S - Cr -	- 45° - VS -	9 - III	A 601 050 02 27 A 601 050 05 27 A 601 050 12 27 A 601 050 21 27 A 601 050 25 27 A 601 050 30 27	<b>26032</b>
[50]	Ø 8 mm				A 102 053 00 26	<b>RK-8H</b>
IN [4]	14,02 x 8 x 39,5	G1 CC			A 601 050 06 24	<b>81-1682</b>
IN [4]	14,20 x 8 x 39,5	G1 CC			A 601 050 07 24	<b>81-1683</b>
IN [4]	14,40 x 8 x 39,5	G1 CC			A 601 050 08 24	<b>81-1684</b>
EX [4]	14,02 x 9 x 37,3	G1 CC			A 601 050 09 24	<b>81-1685</b>
EX [4]	14,20 x 9 x 37,3	G1 CC			A 601 050 10 24	<b>81-1686</b>
IN [1]	40,09 x 33.5 x 7,0	G1 45°			A 601 053 03 31	<b>92-16120</b>
IN [1]	40,58 x 33.5 x 7,3	G1			A 601 053 02 31	<b>92-16121</b>
EX [2]	37,59 x 30.5 x 7,3	G1			A 601 053 02 32	<b>92-16125</b>
EX [1]	37,08 x 30.56 x 7,0	G1 30°			A 601 053 03 32	<b>92-16124</b>
					A 603 050 07 01	<b>50 006 287</b>

Fortsetzung nächste Seite / continued on next page / suite page suivante / continuación página próxima / Продолжение на следующей странице

					Reference	Item No.
[8]	H 40 x 36 x 36				A 040 507 08 25 A 601 050 00 80 A 601 050 03 25 A 601 050 03 80 A 601 050 04 25 A 601 050 05 25 A 601 050 06 25 A 601 050 07 25 A 601 050 08 25	<b>50 006 456</b>

## 85 89

<b>OM 602 Euro 2</b>	<b>980 - 981, 984 - 985, 989</b>							
	02.1995 →	D (LA)	5	2874 cm <sup>3</sup>	2V	75-90 kW	(102-122 PS)	92,40 mm
<b>OM 602</b>	<b>983, 986</b>							
	04.1992 →	D (A)	5	2874 cm <sup>3</sup>	2V	75-90 kW	(102-122 PS)	92,40 mm
<b>OM 602</b>	<b>982</b>							
	03.1996 → 07.1999	D (LA)	5	2874 cm <sup>3</sup>	2V	95 kW	(129 PS)	19,5 92,40 mm

94 823 7..

IN [2]	38,0 x 8 x 106,4	S - Cr -	- 45° -	-	9 - III	A 601 053 04 01 A 601 053 12 01 A 601 053 15 01 A 601 053 17 01	<b>26024</b>
EX [2]	35,0 x 9 x 106,4	A/S - Cr -	- 45° -	VS -	9 - III	A 601 050 02 27 A 601 050 05 27 A 601 050 12 27 A 601 050 21 27 A 601 050 25 27 A 601 050 30 27	<b>26032</b>
[50]	∅ 8 mm					A 102 053 00 26	<b>RK-8H</b>
IN [4]	14,02 x 8 x 39,5	G1 CC				A 601 050 06 24	<b>81-1682</b>
IN [4]	14,20 x 8 x 39,5	G1 CC				A 601 050 07 24	<b>81-1683</b>
IN [4]	14,40 x 8 x 39,5	G1 CC				A 601 050 08 24	<b>81-1684</b>
EX [4]	14,02 x 9 x 37,3	G1 CC				A 601 050 09 24	<b>81-1685</b>
EX [4]	14,20 x 9 x 37,3	G1 CC				A 601 050 10 24	<b>81-1686</b>

						A 602 050 13 01	<b>50 006 337</b> (1)
	(1) Schalenhartguss/chilled cast iron/pièce moulée trempée en surface/fundición en coquilla/Отливка с отбеленным поверхностным слоем						

[8]	H 40 x 36 x 36					A 040 507 08 25 A 601 050 00 80 A 601 050 03 25 A 601 050 03 80 A 601 050 04 25 A 601 050 05 25 A 601 050 06 25 A 601 050 07 25 A 601 050 08 25	<b>50 006 456</b>
-----	----------------	--	--	--	--	---	-------------------

## 86 89

<b>OM 604</b>	<b>910, 912</b>							
	08.1993 → 03.2002	D (NA)	4	2155 cm <sup>3</sup>	4V	55-70 kW	(75-95 PS)	22 86,60 mm

IN [2]	29,0 x 6 x 105,4	S - Cr -	- 45° -	-	22 - III	A 606 053 05 01 A 606 053 06 01 A 606 053 07 01	<b>26264</b>
IN [2]	29,0 x 6 x 105,4	S - Ni -	- 45° -	-	9 -	A 606 053 11 01	<b>26045</b>
EX [2]	26,0 x 6 x 105,7	A - Cr -	- 45° -	-	9 -	A 606 053 06 05 A 606 053 07 05	<b>26046</b>
EX [2]	26,0 x 7 x 105,5	A/S - Cr -	- 45° -	-	9 - III	A 606 050 11 27 A 606 050 14 27	<b>26047</b>

Fortsetzung nächste Seite / continued on next page / suite page suivante / continuación página próxima / Продолжение на следующей странице



					Reference	Item No.
[50] [50]	∅ 6 mm ∅ 7 mm				A 000 053 10 26	LK-6H LK-7H
IN [4] EX [4]	12,50 x 6 x 37,5 12,50 x 7 x 37,5	G1 G2			A 606 053 12 29 A 606 053 02 30	81-26175 81-26178

<b>87</b>		<b>89</b>
<b>OM 601</b>	<b>970</b>	
	02.1996 → 07.2003	D (LA) 4 2299 cm <sup>3</sup> 2V 72 kW (98 PS) 19,5 92,40 mm
<b>OM 661</b>	<b>911</b>	
	01.1996 →	D (NA) 4 2299 cm <sup>3</sup> 2V 57-58 kW (77-79 PS) 21 92,40 mm
91 372 6.., 94 675 6..		

IN [2]	38,0 x 8 x 106,4	S - Cr -	- 45° - -	9 - III	A 601 053 04 01 A 601 053 12 01 A 601 053 15 01 A 601 053 17 01	26024
EX [2]	35,0 x 9 x 106,4	A/S - Cr -	- 45° - VS -	9 - III	A 601 050 02 27 A 601 050 05 27 A 601 050 12 27 A 601 050 21 27 A 601 050 25 27 A 601 050 30 27	26032
[50]	∅ 8 mm				A 102 053 00 26	RK-8H
IN [4] IN [4] IN [4] EX [4] EX [4]	14,02 x 8 x 39,5 14,20 x 8 x 39,5 14,40 x 8 x 39,5 14,02 x 9 x 37,3 14,20 x 9 x 37,3	G1 CC G1 CC G1 CC G1 CC G1 CC			A 601 050 06 24 A 601 050 07 24 A 601 050 08 24 A 601 050 09 24 A 601 050 10 24	81-1682 81-1683 81-1684 81-1685 81-1686
					A 601 050 08 01	50 006 282 (1)
	(1) Schalenhartguss/chilled cast iron/pièce moulée trempée en surface/fundición en coquilla/Отливка с отбеленным поверхностным слоем					
[8]	H 40 x 36 x 36				A 040 507 08 25 A 601 050 00 80 A 601 050 03 25 A 601 050 03 80 A 601 050 04 25 A 601 050 05 25 A 601 050 06 25 A 601 050 07 25 A 601 050 08 25	50 006 456

<b>88</b>		<b>89</b>
<b>OM 662</b>	<b>911</b>	
	01.1996 →	D (NA) 5 2874 cm <sup>3</sup> 2V 70 kW (95 PS) 21 92,40 mm
91 372 6.., 94 675 6..		

IN [2]	38,0 x 8 x 106,4	S - Cr -	- 45° - -	9 - III	A 601 053 04 01 A 601 053 12 01 A 601 053 15 01 A 601 053 17 01	26024
EX [2]	35,0 x 9 x 106,4	A/S - Cr -	- 45° - VS -	9 - III	A 601 050 02 27 A 601 050 05 27 A 601 050 12 27 A 601 050 21 27 A 601 050 25 27 A 601 050 30 27	26032
[50]	∅ 8 mm				A 102 053 00 26	RK-8H

Fortsetzung nächste Seite / continued on next page / suite page suivante / continuación página próxima / Продолжение на следующей странице

					Reference	Item No.
	IN [4]	14,02 x 8 x 39,5	G1 CC		A 601 050 06 24	<b>81-1682</b>
	IN [4]	14,20 x 8 x 39,5	G1 CC		A 601 050 07 24	<b>81-1683</b>
	IN [4]	14,40 x 8 x 39,5	G1 CC		A 601 050 08 24	<b>81-1684</b>
	EX [4]	14,02 x 9 x 37,3	G1 CC		A 601 050 09 24	<b>81-1685</b>
	EX [4]	14,20 x 9 x 37,3	G1 CC		A 601 050 10 24	<b>81-1686</b>
					A 602 050 08 01	<b>50 006 284</b> (1)
	(1) Schalenhartguss/chilled cast iron/pièce moulée trempée en surface/fundición en coquilla/Отливка с отбеленным поверхностным слоем					
	[8]	H 40 x 36 x 36			A 040 507 08 25 A 601 050 00 80 A 601 050 03 25 A 601 050 03 80 A 601 050 04 25 A 601 050 05 25 A 601 050 06 25 A 601 050 07 25 A 601 050 08 25	<b>50 006 456</b>

## 89 89,9

**M 111**
**940 - 941**

 05.1986 → 03.2002 B (NA) 4 1998 cm<sup>3</sup> 4V 100 kW (136 PS) 78,70 mm

	IN [2]	35,0 x 7 x 101,5	S - Cr -	- 45° - -	22 - III	A 111 053 01 01 A 111 053 02 01	<b>26208</b>
	IN [2]	35,0 x 7 x 101,5	S - Ni -	- 45° - -	9 -	A 104 053 12 01 A 104 053 14 01 A 111 053 11 01 A 111 053 21 01 A 111 053 23 01 A 111 053 24 01	<b>26048</b>
	EX [2]	31,0 x 7 x 103,5	A/S - Cr -	- 45° - VS -	22 - III	A 111 050 05 27	<b>261114</b>
	EX [2]	31,0 x 7 x 103,5	RA - Ni -	- 45° - -	9 -	A 111 050 12 27	<b>260490</b>
	[50]	Ø 7 mm					<b>MK-7H</b>
	[50]	Ø 7 mm					<b>RK-7H</b>
	IN/EX [4]	12,56 x 7.02 x 37,5	G1			A 111 053 10 29	<b>81-26172</b>
	IN/EX [4]	12,70 x 7.02 x 37,5	G1			A 111 053 11 29	<b>81-26173</b>
	[8]	H 35 x 24 x 24				A 104 050 12 25	<b>50 006 421</b>

## 90 89,9

**M 104**
**990**

 03.1991 → 10.1998 B (NA) 6 3199 cm<sup>3</sup> 4V 162-170 kW (220-231 PS) 10 84,00 mm

	IN [2]	35,0 x 7 x 101,5	S - Cr -	- 45° - -	22 - III	A 111 053 01 01 A 111 053 02 01	<b>26208</b>
	IN [2]	35,0 x 7 x 101,5	S - Ni -	- 45° - -	9 -	A 104 053 12 01 A 104 053 14 01 A 111 053 11 01 A 111 053 21 01 A 111 053 23 01 A 111 053 24 01	<b>26048</b>
	EX [2]	31,0 x 7 x 103,5	A/S - Cr -	- 45° - VS -	22 - III	A 111 050 05 27	<b>261114</b>
	EX [2]	31,0 x 7 x 103,5	RA - Ni -	- 45° - -	9 -	A 111 050 12 27	<b>260490</b>
	[50]	Ø 7 mm					<b>MK-7H</b>
	[50]	Ø 7 mm					<b>RK-7H</b>

Fortsetzung nächste Seite / continued on next page / suite page suivante / continuación página próxima / Продолжение на следующей странице

					Reference	Item No.
	IN/EX [4] 12,56 x 7.02 x 37,5 IN/EX [4] 12,70 x 7.02 x 37,5 IN [6] 13,50 x 7 x 35,5 EX [6] 13,50 x 8 x 38,0	G1 G1 B1 B1			A 111 053 10 29 A 111 053 11 29 A 104 050 52 24 A 104 050 47 24	<b>81-26172</b> <b>81-26173</b> <b>81-26163</b> <b>81-26166</b>
	ES				A 104 050 74 01	<b>50 006 226</b> (1)
(1) Schalenhartguss/chilled cast iron/pièce moulée trempée en surface/fundición en coquilla/Отливка с отбеленным поверхностным слоем						

<b>91</b>		<b>89,9</b>
<b>M 104</b>	<b>941 - 945</b>	
	09.1992 → 10.2001 B (NA) 6 2799 cm <sup>3</sup> 4V 142-150 kW (193-204 PS) 10 73,50 mm	
<b>M 104</b>	<b>991 - 992, 994 - 996</b>	
	03.1991 → 10.2001 B (NA) 6 3199 cm <sup>3</sup> 4V 155-170 kW (211-231 PS) 10 84,00 mm	

	IN [2] 35,0 x 7 x 101,5 IN [2] 35,0 x 7 x 101,5	S - Cr - S - Ni -	- 45° - - 45° -	- -	22 - III 9 -	A 111 053 01 01 A 111 053 02 01 A 104 053 12 01 A 104 053 14 01 A 111 053 11 01 A 111 053 21 01 A 111 053 23 01 A 111 053 24 01	<b>26208</b> <b>26048</b>
	EX [2] 31,0 x 7 x 103,5 EX [2] 31,0 x 7 x 103,5	A/S - Cr - RA - Ni -	- 45° - VS - - 45° -	- -	22 - III 9 -	A 111 050 05 27 A 111 050 12 27	<b>261114</b> <b>260490</b>
	[50] Ø 7 mm [50] Ø 7 mm						<b>MK-7H</b> <b>RK-7H</b>
	IN/EX [4] 12,56 x 7.02 x 37,5 IN/EX [4] 12,70 x 7.02 x 37,5	G1 G1				A 111 053 10 29 A 111 053 11 29	<b>81-26172</b> <b>81-26173</b>
	ES					A 104 050 74 01	<b>50 006 226</b> (1)
(1) Schalenhartguss/chilled cast iron/pièce moulée trempée en surface/fundición en coquilla/Отливка с отбеленным поверхностным слоем							
	[8] H 35 x 24 x 24					A 104 050 12 25	<b>50 006 421</b>

<b>92</b>		<b>89,9</b>
<b>M 111</b>	<b>960 - 961</b>	
	10.1992 → 05.2000 B (NA) 4 2199 cm <sup>3</sup> 4V 110 kW (150 PS) 86,60 mm	

	IN [2] 35,0 x 7 x 101,5 IN [2] 35,0 x 7 x 101,5	S - Cr - S - Ni -	- 45° - - 45° -	- -	22 - III 9 -	A 111 053 01 01 A 111 053 02 01 A 104 053 12 01 A 104 053 14 01 A 111 053 11 01 A 111 053 21 01 A 111 053 23 01 A 111 053 24 01	<b>26208</b> <b>26048</b>
	EX [2] 31,0 x 7 x 103,5 EX [2] 31,0 x 7 x 103,5	A/S - Cr - RA - Ni -	- 45° - VS - - 45° -	- -	22 - III 9 -	A 111 050 05 27 A 111 050 12 27	<b>261114</b> <b>260490</b>
	[50] Ø 7 mm [50] Ø 7 mm						<b>MK-7H</b> <b>RK-7H</b>
	IN/EX [4] 12,56 x 7.02 x 37,5 IN/EX [4] 12,70 x 7.02 x 37,5	G1 G1				A 111 053 10 29 A 111 053 11 29	<b>81-26172</b> <b>81-26173</b>
	ES					A 111 050 21 01	<b>50 006 376</b> (1)

Fortsetzung nächste Seite / continued on next page / suite page suivante / continuación página próxima / Продолжение на следующей странице

					Reference	Item No.	
(1) Schalenhartguss/chilled cast iron/pièce moulée trempée en surface/fundición en coquilla/Отливка с отбелнным поверхностным слоем							
	[8]	H 35 x 24 x 24			A 104 050 12 25	50 006 421	
<b>93</b>		<b>89,9</b>					
<b>M 111</b>	<b>942, 945 - 946, 948, 950</b>						
	01.1994 → 07.2003		B (NA) 4	1998 cm <sup>3</sup> 4V	95-100 kW (129-136 PS)	78,70 mm	
	IN [2]	35,0 x 7 x 101,5	S - Ni -	- 45° - -	9 -	A 104 053 12 01 A 104 053 14 01 A 111 053 11 01 A 111 053 21 01 A 111 053 23 01 A 111 053 24 01	<b>26048</b>
	EX [2]	31,0 x 7 x 103,5	RA - Ni -	- 45° - -	9 -	A 111 050 12 27	<b>260490</b>
	[50]	∅ 7 mm					<b>RK-7H</b>
	IN/EX [4]	12,56 x 7.02 x 37,5	G1			A 111 053 10 29	<b>81-26172</b>
	IN/EX [4]	12,70 x 7.02 x 37,5	G1			A 111 053 11 29	<b>81-26173</b>
	[8]	H 35 x 24 x 24				A 104 050 12 25	50 006 421
<b>94</b>		<b>89,9</b>					
<b>M 111</b>	<b>943 - 944, 947</b>						
	10.1995 → 03.2003		B (K) 4	1998 cm <sup>3</sup> 4V	132-141 kW (180-192 PS)	78,70 mm (1)	
(1) <b>M 111.943, M 111.944:</b> charged by compressor							
	IN [2]	35,0 x 7 x 101,5	S - Ni -	- 45° - -	9 -	A 104 053 12 01 A 104 053 14 01 A 111 053 11 01 A 111 053 21 01 A 111 053 23 01 A 111 053 24 01	<b>26048</b>
	EX [2]	31,0 x 7 x 103,5	RA - Ni -	- 45° - -	9 -	A 111 050 12 27	<b>260490</b>
	[50]	∅ 7 mm					<b>RK-7H</b>
	IN/EX [4]	12,56 x 7.02 x 37,5	G1			A 111 053 10 29	<b>81-26172</b>
	IN/EX [4]	12,70 x 7.02 x 37,5	G1			A 111 053 11 29	<b>81-26173</b>
		ES				A 111 050 21 01	<b>50 006 376</b> (2)
(2) Schalenhartguss/chilled cast iron/pièce moulée trempée en surface/fundición en coquilla/Отливка с отбелнным поверхностным слоем							
	[8]	H 35 x 24 x 24				A 104 050 12 25	50 006 421
<b>95</b>		<b>89,9</b>					
<b>M 112</b>	<b>912 - 917</b>						
	05.2000 → 03.2010		B (NA) 6	2597 cm <sup>3</sup> 3V	120-130 kW (163-177 PS)	68,20 mm	
<b>M 112</b>	<b>920 - 923</b>						
	12.1996 → 08.2005		B (NA) 6	2799 cm <sup>3</sup> 3V	145-150 kW (197-204 PS) 10	73,50 mm	
<b>M 112</b>	<b>960 - 961</b>						
	02.2001 → 05.2008		B (K) 6	3199 cm <sup>3</sup> 3V	260 kW (354 PS)	84,00 mm	
<b>M 112</b>	<b>940 - 947, 949, 951, 953 - 955</b>						
	12.1996 →		B (NA) 6	3199 cm <sup>3</sup> 3V	140-165 kW (190-224 PS) 10	84,00 mm	
<b>M 113</b>	<b>940 - 944, 948</b>						
	06.1997 → 08.2005		B (NA) 8	4266 cm <sup>3</sup> 3V	199-225 kW (271-306 PS) 10	84,00 mm	
Fortsetzung nächste Seite / continued on next page / suite page suivante / continuación página próxima / Продолжение на следующей странице							

					Reference	Item No.
IN [2]	36,0 x 7 x 119,4	S - Ni -	- 45° - -	1 -	A 113 053 01 01 A 113 053 05 01	<b>261032</b>
EX [2]	41,0 x 7 x 122,3	A - Ni -	- 45° - VS -	1 -	A 113 050 02 27	<b>261033</b>
[50]	Ø 7 mm					<b>LK-2607</b>
IN/EX [4]	12,74 x 7 x 50,0	G1			A 113 053 03 29	<b>81-26183</b>
IN [4]					A 113 050 01 33	<b>50 006 495</b> (1)
IN [4]					A 113 050 00 33	<b>50 006 497</b> (2)
EX [4]					A 113 050 00 34 A 113 050 05 34	<b>50 006 499</b>
	(1) Einlassventil/intake valve/soupape d'admission/válvula de admisión/впускной клапан No.2					
	(2) Einlassventil/intake valve/soupape d'admission/válvula de admisión/впускной клапан No.1					

**96** **89,9**  
**M 111** **955 - 958**  
 03.2000 → 04.2004 B (K) 4 1998 cm<sup>3</sup> 4V 120 kW (163 PS) 9,5 78,70 mm

IN [2]	35,0 x 7 x 101,5	S - Ni -	- 45° - -	9 -	A 104 053 12 01 A 104 053 14 01 A 111 053 11 01 A 111 053 21 01 A 111 053 23 01 A 111 053 24 01	<b>26048</b>
EX [2]	31,0 x 7 x 103,5	RA - Ni -	- 45° - -	9 -	A 111 050 12 27	<b>260490</b>
[50]	Ø 7 mm					<b>RK-7H</b>
IN/EX [4]	12,56 x 7.02 x 37,5	G1			A 111 053 10 29	<b>81-26172</b>
IN/EX [4]	12,70 x 7.02 x 37,5	G1			A 111 053 11 29	<b>81-26173</b>
	ES AS				A 111 050 45 01 A 111 050 47 01	<b>50 007 698</b> (1) <b>50 007 699</b> (1)
	(1) Schalenhartguss/chilled cast iron/pièce moulée trempée en surface/fundición en coquilla/Отливка с отбеленным поверхностным слоем					
[8]	H 35 x 24 x 24				A 104 050 12 25	<b>50 006 421</b>

**97** **89,9**  
**M 111** **951**  
 10.2000 → 05.2002 B (K) 4 1998 cm<sup>3</sup> 4V 95 kW (129 PS) 10,6 78,70 mm  
**M 111** **952**  
 09.2000 → 03.2001 B (NA) 4 1998 cm<sup>3</sup> 4V 95 kW (129 PS) 10,6 78,70 mm

IN [2]	35,0 x 7 x 101,5	S - Ni -	- 45° - -	9 -	A 104 053 12 01 A 104 053 14 01 A 111 053 11 01 A 111 053 21 01 A 111 053 23 01 A 111 053 24 01	<b>26048</b>
EX [2]	31,0 x 7 x 103,5	RA - Ni -	- 45° - -	9 -	A 111 050 12 27	<b>260490</b>
[50]	Ø 7 mm					<b>RK-7H</b>
IN/EX [4]	12,56 x 7.02 x 37,5	G1			A 111 053 10 29	<b>81-26172</b>
IN/EX [4]	12,70 x 7.02 x 37,5	G1			A 111 053 11 29	<b>81-26173</b>
	AS				A 111 050 47 01	<b>50 007 699</b> (1)

Fortsetzung nächste Seite / continued on next page / suite page suivante / continuación página próxima / Продолжение на следующей странице



					Reference	Item No.
(1)	Schalenhartguss/chilled cast iron/pièce moulée trempée en surface/fundición en coquilla/Отливка с отбелнным поверхностным слоем					
[8]	H 35 x 24 x 24				A 104 050 12 25	50 006 421
<b>98</b>	<b>90,9</b>					
<b>M 111 KAT</b>	<b>979</b>					
	02.1995 → 05.2006	BG (NA)	4	2295 cm <sup>3</sup>	4V 95-105 kW (129-143 PS)	8,8 88,40 mm
<b>M 111</b>	<b>984</b>					
	02.1995 → 05.2006	BG (NA)	4	2295 cm <sup>3</sup>	4V 92-105 kW (125-143 PS)	8,8 88,40 mm
94 952 6..., 94 953 6..						
IN [2]	35,0 x 7 x 101,5	S - Ni -	- 45° -	- 9 -	A 104 053 12 01 A 104 053 14 01 A 111 053 11 01 A 111 053 21 01 A 111 053 23 01 A 111 053 24 01	<b>26048</b>
EX [2]	31,0 x 7 x 103,5	RA - Ni -	- 45° -	- 9 -	A 111 050 12 27	<b>260490</b>
[50]	∅ 7 mm					<b>RK-7H</b>
IN/EX [4]	12,56 x 7.02 x 37,5	G1			A 111 053 10 29	<b>81-26172</b>
IN/EX [4]	12,70 x 7.02 x 37,5	G1			A 111 053 11 29	<b>81-26173</b>
[8]	H 35 x 24 x 24				A 104 050 12 25	50 006 421
<b>99</b>	<b>90,9</b>					
<b>M 111</b>	<b>973, 975</b>					
	10.1995 → 12.2000	B (K)	4	2295 cm <sup>3</sup>	4V 138-142 kW (188-193 PS)	8,8 88,40 mm (1)
<b>M 111</b>	<b>970, 974, 977</b>					
	06.1995 → 06.2005	B (NA)	4	2295 cm <sup>3</sup>	4V 110 kW (150 PS)	10,4 88,40 mm
94 952 6..., 94 953 6..						
(1) <b>M 111.973, M 111.975:</b> charged by compressor						
IN [2]	35,0 x 7 x 101,5	S - Ni -	- 45° -	- 9 -	A 104 053 12 01 A 104 053 14 01 A 111 053 11 01 A 111 053 21 01 A 111 053 23 01 A 111 053 24 01	<b>26048</b>
EX [2]	31,0 x 7 x 103,5	RA - Ni -	- 45° -	- 9 -	A 111 050 12 27	<b>260490</b>
[50]	∅ 7 mm					<b>RK-7H</b>
IN/EX [4]	12,56 x 7.02 x 37,5	G1			A 111 053 10 29	<b>81-26172</b>
IN/EX [4]	12,70 x 7.02 x 37,5	G1			A 111 053 11 29	<b>81-26173</b>
	ES				A 111 050 21 01	<b>50 006 376</b> (2)
(2)	Schalenhartguss/chilled cast iron/pièce moulée trempée en surface/fundición en coquilla/Отливка с отбелнным поверхностным слоем					
[8]	H 35 x 24 x 24				A 104 050 12 25	50 006 421
<b>100</b>	<b>90,9</b>					
<b>M 111</b>	<b>978, 980</b>					
	10.1996 → 07.2003	B (NA)	4	2295 cm <sup>3</sup>	4V 105 kW (143 PS)	8,8 88,40 mm
94 952 6..., 94 953 6..						
Fortsetzung nächste Seite / continued on next page / suite page suivante / continuación página próxima / Продолжение на следующей странице						

					Reference	Item No.
IN [2]	35,0 x 7 x 101,5	S - Ni -	- 45° - -	9 -	A 104 053 12 01 A 104 053 14 01 A 111 053 11 01 A 111 053 21 01 A 111 053 23 01 A 111 053 24 01	<b>26048</b>
EX [2]	31,0 x 7 x 103,5	RA - Ni -	- 45° - -	9 -	A 111 050 12 27	<b>260490</b>
[50]	Ø 7 mm					<b>RK-7H</b>
IN/EX [4]	12,56 x 7.02 x 37,5	G1			A 111 053 10 29	<b>81-26172</b>
IN/EX [4]	12,70 x 7.02 x 37,5	G1			A 111 053 11 29	<b>81-26173</b>
[8]	H 35 x 24 x 24				A 104 050 12 25	<b>50 006 421</b>

## 101 90,9

**M 111** **981 - 983**  
03.2000 → 04.2004 B (K) 4 2295 cm<sup>3</sup> 4V 143-145 kW (194-197 PS) 9 88,40 mm  
94 953 6..

IN [2]	35,0 x 7 x 101,5	S - Ni -	- 45° - -	9 -	A 104 053 12 01 A 104 053 14 01 A 111 053 11 01 A 111 053 21 01 A 111 053 23 01 A 111 053 24 01	<b>26048</b>
EX [2]	31,0 x 7 x 103,5	RA - Ni -	- 45° - -	9 -	A 111 050 12 27	<b>260490</b>
[50]	Ø 7 mm					<b>RK-7H</b>
IN/EX [4]	12,56 x 7.02 x 37,5	G1			A 111 053 10 29	<b>81-26172</b>
IN/EX [4]	12,70 x 7.02 x 37,5	G1			A 111 053 11 29	<b>81-26173</b>
	ES AS				A 111 050 45 01 A 111 050 47 01	<b>50 007 698</b> (1) <b>50 007 699</b> (1)
	(1) Schalenhartguss/chilled cast iron/pièce moulée trempée en surface/fundición en coquilla/Отливка с отбеленным поверхностным слоем					
[8]	H 35 x 24 x 24				A 104 050 12 25	<b>50 006 421</b>

## 102 90,9

**OM 616** D (NA) 4 2399 cm<sup>3</sup> 2V 41-55 kW (56-75 PS) 21 92,40 mm  
**OM 616** **912, 917 - 919, 936 - 940, 960, 963**  
D (NA) 4 2399 cm<sup>3</sup> 2V 35-61 kW (48-83 PS) 92,40 mm  
**OM 617** **910, 912 - 913, 919, 931 - 933**  
08.1973 → 12.1991 D (NA) 5 2998 cm<sup>3</sup> 2V 48-65 kW (65-88 PS) 92,40 mm  
**OM 617** **950 - 952**  
02.1978 → 12.1985 D (A) 5 2998 cm<sup>3</sup> 2V 85-92 kW (116-125 PS) 92,40 mm  
93 444 6..

IN [2]	40,0 x 10 x 131,5	S - Cr -	- 30° - -	25 - III	A 616 053 03 01 A 616 053 04 01	<b>2605</b>
EX [2]	34,2 x 10 x 131,1	A/S - Cr -	- 30° - -	25 - III	A 616 050 00 27 A 616 050 01 27 A 616 050 05 27 A 617 050 00 27	<b>261117</b>
IN [4]	14,00 x 10 x 60,0	G1			A 611 053 15 29 A 616 053 03 29	<b>81-2602</b>
EX [4]	14,00 x 10 x 48,5	G1			A 616 053 03 30 A 621 053 36 30	<b>81-2604</b>

					Reference	Item No.
<b>103</b>		<b>90,9</b>				
<b>OM 616</b>		<b>915, 930 - 931</b>				
		01.1977 →	D (NA) 4	2399 cm <sup>3</sup> 2V	38-44 kW (52-60 PS) 21:1	92,40 mm
	IN [2]	39,0 x 10 x 131,5	S - Cr -	- 30° - -	25 -	A 615 053 00 01 A 615 053 01 01 A 615 053 05 01 A 651 053 00 01 <b>2641</b>
	EX [2]	33,2 x 10 x 131,0	A/S - Cr -	- 30° - -	25 - III	A 615 053 04 05 A 615 053 07 05 <b>261118</b>
	IN [4]	14,00 x 10 x 60,0	G1			A 611 053 15 29 A 616 053 03 29 <b>81-2602</b>
	EX [4]	14,00 x 10 x 48,5	G1			A 616 053 03 30 A 621 053 36 30 <b>81-2604</b>
<b>104</b>		<b>91</b>				
<b>M 104</b>		<b>941 (AMG 3.6), 992 (AMG 3.6)</b>				
		09.1992 → 05.2000	B (NA) 6	3606 cm <sup>3</sup> 4V	195-206 kW (265-280 PS)	92,40 mm
	IN [2]	35,0 x 7 x 101,5	S - Cr -	- 45° - -	22 - III	A 111 053 01 01 A 111 053 02 01 <b>26208</b>
	IN [2]	35,0 x 7 x 101,5	S - Ni -	- 45° - -	9 -	A 104 053 12 01 A 104 053 14 01 A 111 053 11 01 A 111 053 21 01 A 111 053 23 01 A 111 053 24 01 <b>26048</b>
	EX [2]	31,0 x 7 x 103,5	A/S - Cr -	- 45° - VS -	22 - III	A 111 050 05 27 <b>261114</b>
	EX [2]	31,0 x 7 x 103,5	RA - Ni -	- 45° - -	9 -	A 111 050 12 27 <b>260490</b>
	[50]	∅ 7 mm				<b>MK-7H</b>
	[50]	∅ 7 mm				<b>RK-7H</b>
	IN/EX [4]	12,56 x 7.02 x 37,5	G1			A 111 053 10 29 <b>81-26172</b>
	IN/EX [4]	12,70 x 7.02 x 37,5	G1			A 111 053 11 29 <b>81-26173</b>
		ES				A 104 050 74 01 <b>50 006 226</b> (1)
		(1) Schalenhartguss/chilled cast iron/pièce moulée trempée en surface/fundición en coquilla/Отливка с отбеленным поверхностным слоем				
	[8]	H 35 x 24 x 24				A 104 050 12 25 <b>50 006 421</b>
<b>105</b>		<b>91</b>				
<b>M 104</b>		<b>996 (AMG 3.6)</b>				
		01.1995 → 07.1998	B (NA) 6	3606 cm <sup>3</sup> 4V	200 kW (272 PS) 10	92,40 mm
	IN [2]	35,0 x 7 x 101,5	S - Cr -	- 45° - -	22 - III	A 111 053 01 01 A 111 053 02 01 <b>26208</b>
	IN [2]	35,0 x 7 x 101,5	S - Ni -	- 45° - -	9 -	A 104 053 12 01 A 104 053 14 01 A 111 053 11 01 A 111 053 21 01 A 111 053 23 01 A 111 053 24 01 <b>26048</b>
	EX [2]	31,0 x 7 x 103,5	A/S - Cr -	- 45° - VS -	22 - III	A 111 050 05 27 <b>261114</b>
	EX [2]	31,0 x 7 x 103,5	RA - Ni -	- 45° - -	9 -	A 111 050 12 27 <b>260490</b>
	[50]	∅ 7 mm				<b>MK-7H</b>
	[50]	∅ 7 mm				<b>RK-7H</b>
	IN/EX [4]	12,56 x 7.02 x 37,5	G1			A 111 053 10 29 <b>81-26172</b>
	IN/EX [4]	12,70 x 7.02 x 37,5	G1			A 111 053 11 29 <b>81-26173</b>
Fortsetzung nächste Seite / continued on next page / suite page suivante / continuación página próxima / Продолжение на следующей странице						

						<b>Reference</b>	<b>Item No.</b>	
[8]	H 35 x 24 x 24					A 104 050 12 25	<b>50 006 421</b>	
<b>106</b>	<b>91</b>							
<b>OM 616</b>	<b>962 (ESP)</b>							
	D	4	2399 cm <sup>3</sup>	2V			92,40 mm	
<b>OM 616</b>	<b>910 - 911, 913 - 914, 916, 932 - 934, 942 - 944, 961</b>							
	D (NA)	4		2V	38-53 kW (52-72 PS)		92,40 mm	
93 444 6..								
	IN [2]	40,0 x 10 x 131,5	S - Cr -	- 30° -	-	25 - III	A 616 053 03 01 A 616 053 04 01 A 616 050 00 27 A 616 050 01 27 A 616 050 05 27 A 617 050 00 27	<b>2605</b>  <b>261117</b>
	EX [2]	34,2 x 10 x 131,1	A/S - Cr -	- 30° -	-	25 - III		
	IN [4]	14,00 x 10 x 60,0	G1				A 611 053 15 29 A 616 053 03 29	<b>81-2602</b>
	EX [4]	14,00 x 10 x 48,5	G1				A 616 053 03 30 A 621 053 36 30	<b>81-2604</b>
<b>107</b>	<b>92</b>							
<b>M 116</b>	<b>980 - 982, 984 - 985, 990 - 993</b>							
	04.1968 →	B (NA)	8	3499 cm <sup>3</sup>	2V	132-152 kW (180-205 PS)	65,80 mm	
<b>M 116</b>	<b>983</b>							
	08.1972 → 02.1976	B	8	3499 cm <sup>3</sup>	2V	147 kW (200 PS) 9,5	65,80 mm	
<b>M 117</b>	<b>981 - 986, 992 - 993</b>							
		B (NA)	8	4520 cm <sup>3</sup>	2V	119-165 kW (162-225 PS)	85,00 mm	
	IN [2]	44,0 x 9 x 117,0	S - Cr -	- 45° -	VS -	9 - III	A 116 050 01 26 A 116 050 02 26	<b>2639</b>
	EX [1]	37,1 x 11 x 118,0	A/S - Cr -	- 45° -	-	9 - III	A 110 050 00 27	<b>261108</b> (1)
	(1) Kegelstückfixierung/cotter fixation/fixation de clavettes/fijación de chavetas/Крепление конического сухаря Ø 9 mm							
	[50]	Ø 9 mm					A 115 053 00 26	<b>RK-9H</b>
	IN [6]	14,24 x 9 x 47,5	B1				A 116 050 49 24	<b>81-26119</b>
	IN [4]	14,04 x 9 x 47,5	B1				A 116 050 47 24	<b>81-26118</b>
	IN [4]	14,04 x 9 x 47,5	B1				A 116 050 36 24	<b>81-2685</b>
	EX [4]	15,00 x 11 x 49,0	B1				A 116 050 41 24	<b>81-2688</b>
<b>108</b>	<b>92</b>							
<b>M 116</b>	<b>960 - 961</b>							
	07.1980 → 08.1984	B (NA)	8	3818 cm <sup>3</sup>	2V	120-160 kW (163-218 PS) 9	71,80 mm	
	IN [2]	39,1 x 9 x 117,0	S - -	- 45° -	VS -	9 - III	A 116 050 04 26	<b>26052</b>
	IN [2]	44,0 x 9 x 117,0	S - Cr -	- 45° -	VS -	9 - III	A 116 050 01 26 A 116 050 02 26	<b>2639</b>
	EX [2]	37,1 x 9 x 118,2	A/S - Cr -	- 45° -	-	9 - III	A 116 050 00 27	<b>261109</b>
	[50]	Ø 9 mm					A 115 053 00 26	<b>RK-9H</b>
	IN [6]	14,24 x 9 x 47,5	B1				A 116 050 49 24	<b>81-26119</b>
	IN [4]	14,04 x 9 x 47,5	B1				A 116 050 47 24	<b>81-26118</b>
	IN [4]	14,04 x 9 x 47,5	B1				A 116 050 36 24	<b>81-2685</b>
	EX [4]	15,04 x 9 x 50,5	B1				A 116 050 53 24	<b>81-26121</b>
	EX [4]	15,24 x 9 x 50,5	B1				A 116 050 55 24	<b>81-26122</b>
<b>109</b>	<b>92</b>							
<b>M 116</b>	<b>964 - 965</b>							
	10.1985 → 06.1991	B (NA)	8	4196 cm <sup>3</sup>	2V	150-170 kW (204-231 PS)	78,90 mm	
Fortsetzung nächste Seite / continued on next page / suite page suivante / continuación página próxima / Продолжение на следующей странице								

M

					Reference	Item No.
IN [2]	44,0 x 9 x 117,0	S - Cr -	- 45° - VS -	9 - III	A 116 050 01 26 A 116 050 02 26	<b>2639</b>
EX [2]	39,1 x 9 x 118,2	A/S - Cr -	- 45° - VS -	9 - III	A 117 050 00 27 A 117 050 01 27	<b>261111</b>
[50]	Ø 9 mm				A 115 053 00 26	<b>RK-9H</b>
IN [6]	14,24 x 9 x 47,5	B1			A 116 050 49 24	<b>81-26119</b>
IN [4]	14,04 x 9 x 47,5	B1			A 116 050 47 24	<b>81-26118</b>
EX [4]	15,04 x 9 x 50,5	B1			A 116 050 53 24	<b>81-26121</b>
EX [4]	15,24 x 9 x 50,5	B1			A 116 050 55 24	<b>81-26122</b>
	AS ES				A 117 051 09 01 A 117 051 08 01	<b>50 006 281</b> (1) <b>50 006 280</b> (1)

(1) Schalenhartguss/chilled cast iron/pièce moulée trempée en surface/fundición en coquilla/Отливка с отбеленным поверхностным слоем

## 110 92

M 119

**971, 975, 981, 985**

02.1991 → 02.1999 B (NA) 8 4196 cm<sup>3</sup> 4V 205-214 kW (279-291 PS) 78,90 mm

IN/EX [4]	12,56 x 7.02 x 37,5	G1			A 111 053 10 29	<b>81-26172</b>
IN/EX [4]	12,70 x 7.02 x 37,5	G1			A 111 053 11 29	<b>81-26173</b>
IN [6]	13,50 x 7 x 35,5	B1			A 104 050 52 24	<b>81-26163</b>
[8]	H 35 x 24 x 24				A 104 050 12 25	<b>50 006 421</b>

## 111 92,9

M 272

**960 - 961, 963 - 967, 970 - 972, 975, 978, 980, 988**

06.2004 → B (NA) 6 3498 cm<sup>3</sup> 4V 170-215 kW (231-292 PS) 86,00 mm

M 273

**922 - 924**

12.2005 → 12.2013 B (NA) 8 4663 cm<sup>3</sup> 4V 250 kW (340 PS) 86,00 mm

IN [2]	39,6 x 6 x 108,8	S - Cr -	- 45° - -	22 - III	A 272 053 05 01 A 272 053 06 01	<b>261132</b>
EX [2]	29,9 x 6 x 107,3	A/S - Cr -	- 45° - -	22 - III	A 272 050 06 27 A 272 050 08 27 A 272 050 16 27	<b>261133</b>
[50]	Ø 6 mm				A 000 053 11 26	<b>MK-6H</b>
[8]	H 12 x 34,6 x 34,6				A 160 050 01 80 A 642 050 00 80 A 642 050 01 80	<b>50 006 432</b>

## 112 92,9

M 272

**968 - 969, 974, 977, 979, 982 - 985**

04.2006 → B (NA) 6 3498 cm<sup>3</sup> 4V 190-232 kW (258-316 PS) 86,00 mm

[8]	H 12 x 34,6 x 34,6				A 160 050 01 80 A 642 050 00 80 A 642 050 01 80	<b>50 006 432</b>
-----	--------------------	--	--	--	---	-------------------

## 113 92,9

M 276

**950, 952, 955 - 958**

06.2008 → B (NA) 6 3498 cm<sup>3</sup> 4V 182-245 kW (248-333 PS) 12,2 86,00 mm

M 278 Euro 5

**928**

02.2012 → 10.2019 B (LA) 8 4663 cm<sup>3</sup> 4V 270-335 kW (367-456 PS) 10,5 86,00 mm

IN [2]	37,0 x 6 x 104,2	S - Cr -	- 45° - -	22 - III	A 278 050 01 26	<b>261150</b> <small>NEW</small>
EX [2]	30,1 x 6 x 107,3	RA/S- Cr - Na	- 45° - VS -	22 - III	A 276 050 00 27	<b>261151</b> <small>NEW</small>
[50]	Ø 6 mm				A 000 053 11 26	<b>MK-6H</b>

Fortsetzung nächste Seite / continued on next page / suite page suivante / continuación página próxima / Продолжение на следующей странице



					Reference	Item No.	
[8]	H 12 x 34,6 x 34,6				A 160 050 01 80 A 642 050 00 80 A 642 050 01 80	<b>50 006 432</b>	
<b>114</b>	<b>92,9</b>						
<b>M 272</b>	<b>991</b>						
	04.2009 → 06.2015	B (NA)	6	3498 cm <sup>3</sup> 4V	200 kW (272 PS)	12,2 86,00 mm	
IN [2]	39,6 x 6 x 108,8	S - Cr -	-	45° -	22 - III	A 272 053 05 01 A 272 053 06 01	<b>261132</b>
EX [2]	29,9 x 6 x 107,3	A/S - Cr -	-	45° -	22 - III	A 272 050 06 27 A 272 050 08 27 A 272 050 16 27	<b>261133</b>
[50]	∅ 6 mm					A 000 053 11 26	<b>MK-6H</b>
<b>115</b>	<b>92,9</b>						
<b>M 278 Euro 5</b>	<b>920, 922, 927, 932</b>						
	02.2011 →	B (LA)	8	4663 cm <sup>3</sup> 4V	300-335 kW (408-455 PS)	10,5 86,00 mm	
IN [2]	37,0 x 6 x 104,2	S - Cr -	-	45° -	22 - III	A 278 050 01 26	<b>261150</b> <small>NEW</small>
[50]	∅ 6 mm					A 000 053 11 26	<b>MK-6H</b>
[8]	H 12 x 34,6 x 34,6					A 160 050 01 80 A 642 050 00 80 A 642 050 01 80	<b>50 006 432</b>
<b>116</b>	<b>92,9</b>						
<b>M 278 Euro 5</b>	<b>929</b>						
	05.2013 → 10.2017	B (LA)	8	4663 cm <sup>3</sup> 4V	320-338 kW (435-460 PS)	10,5 86,00 mm	
IN [2]	37,0 x 6 x 104,2	S - Cr -	-	45° -	22 - III	A 278 050 01 26	<b>261150</b> <small>NEW</small>
[50]	∅ 6 mm					A 000 053 11 26	<b>MK-6H</b>
<b>117</b>	<b>93,75</b>						
<b>M 115</b>	<b>974</b>						
	03.1979 → 03.1982	B	4	2307 cm <sup>3</sup> 2V	66 kW (90 PS)	8:1 83,60 mm	
<b>M 115</b>	<b>951 - 952, 954 - 955, 958, 970 - 973</b>						
	1973 → 07.1993	B (NA)	4	2307 cm <sup>3</sup> 2V	59-81 kW (80-110 PS)	83,60 mm	
IN [2]	47,0 x 9 x 128,6	S - Cr -	-	45° - VS -	1 -	A 115 050 02 26	<b>26017</b>
EX [1]	37,1 x 11 x 113,2	A/S - Cr -	-	45° -	9 - III	A 115 050 00 27 A 115 050 01 27 A 129 053 00 05 A 129 053 01 05 A 130 053 01 05 A 290 053 01 05	<b>261106</b>
[50]	∅ 9 mm					A 115 053 00 26	<b>RK-9H</b>
IN [4]	14,04 x 9 x 55,0	B1				A 130 050 01 24	<b>81-2667</b>
IN [4]	14,24 x 9 x 55,0	B1				A 130 050 02 24	<b>81-2668</b>
EX [4]	15,04 x 11 x 45,0	B1				A 108 050 05 24	<b>81-2659</b>
EX [4]	15,24 x 11 x 45,0	B1				A 108 050 07 24	<b>81-2660</b>

M

					Reference	Item No.	
<b>118</b>	<b>95,5</b>						
<b>M 102</b>	<b>942 - 943, 959, 980 - 981, 998</b>						
93 968 6..	01.1968 →	B (NA)	4	2299 cm <sup>3</sup> 2V	70-100 kW (95-136 PS)	80,25 mm	
	IN [2]	43,0 x 8 x 114,9	S - Cr -	- 45° - -	1 - III	A 102 053 13 01 A 102 053 16 01 A 102 053 18 01 A 102 053 15 01 A 102 053 17 01	<b>26160</b>
	IN [2]	46,0 x 8 x 114,9	S - Cr -	- 45° - -	1 - III		<b>26135</b>
	EX [2]	39,0 x 9 x 115,9	A/S - Cr -	- 45° - -	1 - III		<b>261107</b> (1)
	(1) IAM specification / Kegelstückfixierung/cotter fixation/fixation de clavettes/fijación de chavetas/ Крепление конического сухаря Ø 8 mm						
	[50]	Ø 8 mm				A 102 053 00 26	<b>RK-8H</b>
	IN [4]	14,03 x 8 x 46,0	B1			A 102 050 09 24 A 102 050 17 24	<b>81-2631</b>
	IN [4]	14,04 x 8 x 46,0	B1			A 102 050 89 24	<b>81-26145</b>
	IN [4]	14,23 x 8 x 46,0	B1			A 102 050 10 24	<b>81-2632</b>
	EX [4]	14,03 x 9 x 51,0	B1			A 102 050 12 24 A 102 050 18 24	<b>81-2634</b>
	EX [4]	14,04 x 9 x 51,0	B1			A 102 050 05 62	<b>81-26148</b>
	EX [4]	14,23 x 9 x 51,0	B1			A 102 050 04 62 A 102 050 13 24	<b>81-2635</b>
						A 102 050 02 01	<b>50 006 212</b> (2)
	(2) Schalenhartguss/chilled cast iron/pièce moulée trempée en surface/fundición en coquilla/Отливка с отбеленным поверхностным слоем						
<b>119</b>	<b>95,5</b>						
<b>M 102</b>	<b>945 - 946, 958, 979, 982, 985, 987, 996 - 997</b>						
	04.1982 → 07.2000	B (NA)	4	2299 cm <sup>3</sup> 2V	70-100 kW (95-136 PS)	80,25 mm	
<b>M 102</b>	<b>989</b>						
93 968 6..	04.1982 → 07.1993	B (NA)	4	2298 cm <sup>3</sup> 2V	93 kW (126 PS) 9	80,30 mm	
	IN [2]	46,0 x 8 x 114,9	S - Cr -	- 45° - -	1 - III	A 102 053 15 01 A 102 053 17 01	<b>26135</b>
	EX [2]	39,0 x 9 x 115,9	A/S - Cr -	- 45° - -	1 - III		<b>261107</b> (1)
	(1) IAM specification / Kegelstückfixierung/cotter fixation/fixation de clavettes/fijación de chavetas/ Крепление конического сухаря Ø 8 mm						
	[50]	Ø 8 mm				A 102 053 00 26	<b>RK-8H</b>
	IN [4]	14,03 x 8 x 46,0	B1			A 102 050 09 24 A 102 050 17 24	<b>81-2631</b>
	IN [4]	14,04 x 8 x 46,0	B1			A 102 050 89 24	<b>81-26145</b>
	IN [4]	14,23 x 8 x 46,0	B1			A 102 050 10 24	<b>81-2632</b>
	EX [4]	14,03 x 9 x 51,0	B1			A 102 050 12 24 A 102 050 18 24	<b>81-2634</b>
	EX [4]	14,04 x 9 x 51,0	B1			A 102 050 05 62	<b>81-26148</b>
	EX [4]	14,23 x 9 x 51,0	B1			A 102 050 04 62 A 102 050 13 24	<b>81-2635</b>
						A 102 050 55 01	<b>50 006 222</b> (2)
	(2) Schalenhartguss/chilled cast iron/pièce moulée trempée en surface/fundición en coquilla/Отливка с отбеленным поверхностным слоем						
Fortsetzung nächste Seite / continued on next page / suite page suivante / continuación página próxima / Продолжение на следующей странице							

					Reference	Item No.	
[8]	H 14 x 30				A 103 050 00 80	50 006 454	
<b>120</b>	<b>95,5</b>						
<b>M 102</b>	<b>983</b>						
	04.1984 → 08.1988	B (NA)	4	2299 cm <sup>3</sup>	4V 125-136 kW (170-185 PS)	10,5 80,25 mm	
[50]	∅ 7 mm				A 102 053 02 26	RK-7	
IN [4]	13,00 x 7 x 45,5	B1			A 102 050 40 24	81-26106	
EX [4]	13,00 x 8 x 43,0	B1			A 102 050 37 24	81-26109	
<b>121</b>	<b>95,5</b>						
<b>M 102</b>	<b>992</b>						
	05.1990 → 08.1993	B (NA)	4	2498 cm <sup>3</sup>	2V 173 kW (235 PS)	9,7 87,20 mm	
<b>M 102</b>	<b>990 - 991</b>						
	09.1988 → 08.1993	B (NA)	4	2498 cm <sup>3</sup>	4V 143-150 kW (195-204 PS)	9,7 87,20 mm	
[50]	∅ 7 mm				A 102 053 02 26	RK-7	
IN [4]	13,00 x 7 x 43,0	B1			A 102 050 67 24	81-26139	
EX [4]	13,00 x 8 x 44,0	B1			A 102 050 83 24	81-26142	
<b>122</b>	<b>96,5</b>						
<b>M 117</b>	<b>960 - 961</b>						
	06.1978 → 08.1989	B (NA)	8	4973 cm <sup>3</sup>	2V 170-180 kW (231-245 PS)	8,8 85,00 mm	
IN [2]	44,0 x 9 x 117,0	S - Cr -		- 45° - VS -	9 - III	A 116 050 01 26 A 116 050 02 26	2639
IN [2]	46,0 x 9 x 117,0	S - Cr -		- 45° - VS -	9 - III	A 117 050 01 26	26112
EX [2]	39,1 x 9 x 118,2	A/S - Cr -		- 45° - VS -	9 - III	A 117 050 00 27 A 117 050 01 27	261111
[50]	∅ 9 mm				A 115 053 00 26	RK-9H	
IN [6]	14,24 x 9 x 47,5	B1			A 116 050 49 24	81-26119	
IN [4]	14,04 x 9 x 47,5	B1			A 116 050 47 24	81-26118	
IN [4]	14,04 x 9 x 47,5	B1			A 116 050 36 24	81-2685	
EX [4]	15,04 x 9 x 50,5	B1			A 116 050 53 24	81-26121	
EX [4]	15,24 x 9 x 50,5	B1			A 116 050 55 24	81-26122	
<b>123</b>	<b>96,5</b>						
<b>M 117</b>	<b>962 - 965</b>						
	12.1979 → 12.1994	B (NA)	8	4973 cm <sup>3</sup>	2V 164-195 kW (223-265 PS)	85,00 mm	
IN [2]	44,0 x 9 x 117,0	S - Cr -		- 45° - VS -	9 - III	A 116 050 01 26 A 116 050 02 26	2639
IN [2]	46,0 x 9 x 117,0	S - Cr -		- 45° - VS -	9 - III	A 117 050 01 26	26112
EX [2]	39,1 x 9 x 118,2	A/S - Cr -		- 45° - VS -	9 - III	A 117 050 00 27 A 117 050 01 27	261111
[50]	∅ 9 mm				A 115 053 00 26	RK-9H	
IN [6]	14,24 x 9 x 47,5	B1			A 116 050 49 24	81-26119	
IN [4]	14,04 x 9 x 47,5	B1			A 116 050 47 24	81-26118	
EX [4]	15,04 x 9 x 50,5	B1			A 116 050 53 24	81-26121	
EX [4]	15,24 x 9 x 50,5	B1			A 116 050 55 24	81-26122	
	ES				A 117 051 08 01	50 006 280 (1)	
	AS				A 117 051 09 01	50 006 281 (1)	
	(1) Schalenhartguss/chilled cast iron/pièce moulée trempée en surface/fundición en coquilla/Отливка с отбелсным поверхностным слоем						

M

					Reference	Item No.
<b>124</b>	<b>96,5</b>					
<b>M 117</b>	<b>967 - 968</b> 09.1985 →	B (NA) 8	5547 cm <sup>3</sup> 2V	169-220 kW	(230-300 PS) 10	94,80 mm
	IN [2] 44,0 x 9 x 117,0	S - Cr -	- 45° - VS -	9 - III	A 116 050 01 26 A 116 050 02 26	<b>2639</b>
	IN [2] 46,0 x 9 x 117,0	S - Cr -	- 45° - VS -	9 - III	A 117 050 01 26	<b>26112</b>
	EX [2] 39,1 x 9 x 118,2	A/S - Cr -	- 45° - VS -	9 - III	A 117 050 00 27 A 117 050 01 27	<b>261111</b>
	[50] ∅ 9 mm				A 115 053 00 26	<b>RK-9H</b>
	IN [6] 14,24 x 9 x 47,5	B1			A 116 050 49 24	<b>81-26119</b>
	IN [4] 14,04 x 9 x 47,5	B1			A 116 050 47 24	<b>81-26118</b>
	EX [4] 15,04 x 9 x 50,5	B1			A 116 050 53 24	<b>81-26121</b>
	EX [4] 15,24 x 9 x 50,5	B1			A 116 050 55 24	<b>81-26122</b>
<b>125</b>	<b>96,5</b>					
<b>M 119</b>	<b>960, 970, 972, 974, 980, 982, 985 (AMG 5.0)</b> 09.1989 → 10.2001	B (NA) 8	4973 cm <sup>3</sup> 4V	235-255 kW	(320-347 PS)	85,00 mm
	IN/EX [4] 12,56 x 7.02 x 37,5	G1			A 111 053 10 29	<b>81-26172</b>
	IN/EX [4] 12,70 x 7.02 x 37,5	G1			A 111 053 11 29	<b>81-26173</b>
	IN [6] 13,50 x 7 x 35,5	B1			A 104 050 52 24	<b>81-26163</b>
	[8] H 35 x 24 x 24				A 104 050 12 25	<b>50 006 421</b>
<b>126</b>	<b>97</b>					
<b>M 352</b>	<b>921, 923 - 924, 929</b> 01.1980 →	B	6 5675 cm <sup>3</sup> 2V	93 kW	(126 PS)	128,00 mm
	IN [6] 15,03 x 9 x 72,0	G1			A 352 053 12 29	<b>81-1666</b>
	IN [6] 15,04 x 9 x 72,0	G1			A 352 053 22 29 A 366 053 07 29	<b>81-1674</b>
	EX [6] 15,04 x 10 x 67,0	G1			A 352 053 37 30 A 366 053 02 30	<b>81-1676</b>
	IN [1] 45,08 x 37 x 8,3	G1 45°			A 352 053 16 31 A 352 053 22 31 A 352 053 31 31	<b>92-16112</b>
	IN [1] 45,87 x 37 x 8,2	G1 45°			A 352 053 35 31 A 352 053 38 31 A 352 053 40 31	<b>92-16114</b>
	EX [2] 38,07 x 30 x 8,5	G1 45°			A 366 053 16 32	<b>92-16109</b>
	EX [1] 38,38 x 30 x 8,5	G1 45°			A 352 053 16 32 A 352 053 21 32	<b>92-16131</b>
	[12] M 28 x 60				A 352 054 05 01	<b>20 1003 35260</b>
<b>127</b>	<b>97</b>					
<b>M 112</b>	<b>970, 972 - 973, 975 - 976</b> 08.2002 →	B (NA) 6	3724 cm <sup>3</sup> 3V	165-180 kW	(224-245 PS) 10	84,00 mm
<b>M 113</b>	<b>960 - 969, 971</b> 04.1998 →	B (NA) 8	4966 cm <sup>3</sup> 3V	215-225 kW	(292-306 PS)	84,00 mm
<b>M 113</b>	<b>980 - 982, 984, 986 - 989</b> 08.1997 →	B (NA) 8	5439 cm <sup>3</sup> 3V	255-294 kW	(347-400 PS)	92,00 mm
<b>M 113</b>	<b>962 AMG</b>	B	8 5439 cm <sup>3</sup> 3V	255-260 kW	(347-354 PS) 10,5:1	92,00 mm
<b>M 113</b>	<b>990 - 993, 995</b> 08.1999 →	B (K) 8	5439 cm <sup>3</sup> 3V	349-380 kW	(475-517 PS) 9	92,00 mm
	IN [2] 38,0 x 7 x 119,1	S - Ni -	- 45° - -	1 - III	A 113 053 02 01 A 113 053 06 01	<b>261034</b>
	EX [2] 43,0 x 7 x 121,8	A - Ni -	- 45° - VS -	1 -	A 113 050 03 27	<b>261035</b>

Fortsetzung nächste Seite / continued on next page / suite page suivante / continuación página próxima / Продолжение на следующей странице

					Reference	Item No.
[50]	Ø 7 mm					LK-2607
IN/EX [4]	12,74 x 7 x 50,0	G1			A 113 053 03 29	81-26183
IN [4] IN [4] EX [4]					A 113 050 01 33 A 113 050 00 33 A 113 050 00 34 A 113 050 05 34	50 006 495 (1) 50 006 497 (2) 50 006 499
	(1) Einlassventil/intake valve/soupape d'admission/válvula de admisión/впускной клапан No.2					
	(2) Einlassventil/intake valve/soupape d'admission/válvula de admisión/впускной клапан No.1					

**128**
**97**
**M 343**
**920**

 AL 4 3780 cm<sup>3</sup> 2V 70 kW (95 PS) 17:1 128,00 mm

IN [2]	43,0 x 9 x 140,5	A/S - Cr -	- 30° - -	5 - III	A 366 050 02 26	16109
IN [2]	44,0 x 9 x 140,5	A/S - Cr -	- 45° - -	5 - III	A 352 050 00 26 A 352 050 01 26 A 352 053 01 01	16136
EX [2]	36,0 x 10 x 140,5	A/S - Cr -	- 45° - -	5 - III	A 366 050 02 27	16122
EX [2]	36,0 x 10 x 140,5	S - Cr -	- 45° - VS -	5 - III	A 352 053 15 05	1604
EX [2]	36,0 x 10 x 140,6	A/S - Cr -	- 45° - -	5 - III	A 321 053 09 05 A 366 050 00 27 A 366 050 01 27 A 366 050 05 27 A 366 050 06 27 A 376 050 00 27 A 376 050 01 27	16106
IN [6]	15,03 x 9 x 72,0	G1			A 352 053 12 29	81-1666
IN [6]	15,04 x 9 x 72,0	G1			A 352 053 22 29 A 366 053 07 29	81-1674
EX [6]	15,03 x 10 x 67,0	G1			A 352 053 20 30	81-1670
EX [6]	15,04 x 10 x 67,0	G1			A 352 053 37 30 A 366 053 02 30	81-1676
IN [1]	45,08 x 37 x 8,3	G1 45°			A 352 053 16 31 A 352 053 22 31 A 352 053 31 31	92-16112
IN [1]	45,87 x 37 x 8,2	G1 45°			A 352 053 35 31 A 352 053 38 31 A 352 053 40 31	92-16114
EX [2]	38,07 x 30 x 8,5	G1 45°			A 366 053 16 32	92-16109
EX [1]	38,38 x 30 x 8,5	G1 45°			A 352 053 16 32 A 352 053 21 32	92-16131
[12]	M 28 x 60				A 352 054 05 01	20 1003 35260

**129**
**97**
**OM 352**
**956 - 958, 960 - 962**

 1964 → D 6 5675 cm<sup>3</sup> 2V 128,00 mm

**OM 352**
**901, 904 - 905, 907, 909 - 912, 914 - 915, 917, 930 - 935, 939, 942 - 945, 948, 953 - 955, 959, 964 - 967, 970 - 976, 978 - 979, 983, 985 - 987, 991 - 992, 996, 999**

 D (NA) 6 5675 cm<sup>3</sup> 2V 69-97 kW (94-132 PS) 128,00 mm (1)

**OM 353**
**903, 915 - 917**

 10.1969 → D (NA) 6 5675 cm<sup>3</sup> 2V 81-96 kW (110-130 PS) 17:1 128,00 mm

90 274 8.., 92 581 6.., 93 750 6.., 93 882 6..

 (1) **OM 352.904, OM 352.909:** OM 352 ... II.Series 1966 -

Fortsetzung nächste Seite / continued on next page / suite page suivante / continuación página próxima / Продолжение на следующей странице



					Reference	Item No.
	IN [2] 44,0 x 9 x 140,5	A/S - Cr -	- 45° - -	5 - III	A 352 050 00 26 A 352 050 01 26 A 352 053 01 01	<b>16136</b>
	EX [2] 36,0 x 10 x 140,5	A/S - Cr -	- 45° - -	5 - III	A 366 050 02 27	<b>16122</b>
	EX [2] 36,0 x 10 x 140,5	S - Cr -	- 45° - VS -	5 - III	A 352 053 15 05	<b>1604</b>
	EX [2] 36,0 x 10 x 140,6	A/S - Cr -	- 45° - -	5 - III	A 321 053 09 05 A 366 050 00 27 A 366 050 01 27 A 366 050 05 27 A 366 050 06 27 A 376 050 00 27 A 376 050 01 27	<b>16106</b>
	IN [6] 15,00 x 9 x 78,0	G1			A 312 053 02 30	<b>81-1609</b>
	IN [6] 15,03 x 9 x 72,0	G1			A 352 053 12 29	<b>81-1666</b>
	IN [6] 15,04 x 9 x 72,0	G1			A 352 053 22 29 A 366 053 07 29	<b>81-1674</b>
	EX [6] 15,00 x 10 x 73,0	G1			A 352 053 16 30	<b>81-1658</b>
	EX [6] 15,03 x 10 x 67,0	G1			A 352 053 20 30	<b>81-1670</b>
	EX [6] 15,04 x 10 x 67,0	G1			A 352 053 37 30 A 366 053 02 30	<b>81-1676</b>
	EX [6] 15,20 x 10 x 73,0	G1			A 352 053 18 30	<b>81-1659</b>
	IN [1] 45,08 x 37 x 8,3	G1 45°			A 352 053 16 31 A 352 053 22 31 A 352 053 31 31	<b>92-16112</b>
	IN [1] 45,87 x 37 x 8,2	G1 45°			A 352 053 35 31 A 352 053 38 31 A 352 053 40 31	<b>92-16114</b>
	EX [2] 38,07 x 30 x 8,5	G1 45°			A 366 053 16 32	<b>92-16109</b>
	EX [1] 38,38 x 30 x 8,5	G1 45°			A 352 053 16 32 A 352 053 21 32	<b>92-16131</b>
	739 mm				A 352 050 44 01	<b>20 1003 35200 (2)</b>
	(2) Zahnrad aufgeschumpft/gear shrunk on/pignon emmanché/rueda dentada zunchada/зубчатое колесо запрессовано на горячую					
	[12] M 28 x 60				A 352 054 05 01	<b>20 1003 35260</b>
	I [1]				A 352 050 10 33 A 366 050 04 33	<b>20 1003 36602 (3)</b>
	(3) IN					

**130**
**97**
**OM 352**
**902 - 903, 906, 908, 936, 938, 963, 969, 980 - 982, 984, 989 - 990, 993, 997 - 998**

D (NA) 6 5675 cm<sup>3</sup> 2V 52-96 kW (70-131 PS) 128,00 mm

**OM 353**
**900 - 902, 904 - 905, 940 - 946, 960 - 966, 968 - 969, 980**

05.1969 → D (NA) 6 5675 cm<sup>3</sup> 2V 62-96 kW (84-130 PS) 128,00 mm

**OM 353**
**973**

07.1976 → 12.1984 D (A) 6 5675 cm<sup>3</sup> 2V 92 kW (125 PS) 16,5:1 128,00 mm

90 274 8..., 93 882 6..

Fortsetzung nächste Seite / continued on next page / suite page suivante / continuación página próxima / Продолжение на следующей странице

					Reference	Item No.
	IN [2] 44,0 x 9 x 140,5	A/S - Cr -	- 45° - -	5 - III	A 352 050 00 26 A 352 050 01 26 A 352 053 01 01	<b>16136</b>
	EX [2] 36,0 x 10 x 140,5	A/S - Cr -	- 45° - -	5 - III	A 366 050 02 27	<b>16122</b>
	EX [2] 36,0 x 10 x 140,5	S - Cr -	- 45° - VS -	5 - III	A 352 053 15 05	<b>1604</b>
	EX [2] 36,0 x 10 x 140,6	A/S - Cr -	- 45° - -	5 - III	A 321 053 09 05 A 366 050 00 27 A 366 050 01 27 A 366 050 05 27 A 366 050 06 27 A 376 050 00 27 A 376 050 01 27	<b>16106</b>
	IN [6] 15,00 x 9 x 78,0	G1			A 312 053 02 30	<b>81-1609</b>
	IN [6] 15,03 x 9 x 72,0	G1			A 352 053 12 29	<b>81-1666</b>
	IN [6] 15,04 x 9 x 72,0	G1			A 352 053 22 29 A 366 053 07 29	<b>81-1674</b>
	EX [6] 15,00 x 10 x 73,0	G1			A 352 053 16 30	<b>81-1658</b>
	EX [6] 15,03 x 10 x 67,0	G1			A 352 053 20 30	<b>81-1670</b>
	EX [6] 15,04 x 10 x 67,0	G1			A 352 053 37 30 A 366 053 02 30	<b>81-1676</b>
	EX [6] 15,20 x 10 x 73,0	G1			A 352 053 18 30	<b>81-1659</b>
	IN [1] 45,08 x 37 x 8,3	G1 45°			A 352 053 16 31 A 352 053 22 31 A 352 053 31 31	<b>92-16112</b>
	IN [1] 45,87 x 37 x 8,2	G1 45°			A 352 053 35 31 A 352 053 38 31 A 352 053 40 31	<b>92-16114</b>
	EX [2] 38,07 x 30 x 8,5	G1 45°			A 366 053 16 32	<b>92-16109</b>
	EX [1] 38,38 x 30 x 8,5	G1 45°			A 352 053 16 32 A 352 053 21 32	<b>92-16131</b>
	739 mm 739 mm				A 352 050 44 01 A 352 050 49 01	<b>20 1003 35200</b> (1) <b>20 1003 35201</b> (2)
	(1) Zahnrad aufgeschrumpft/gear shrinked on/pignon emmanché/rueda dentada zunchada/зубчатое колесо запрессовано на горячую					
	(2) Zahnrad angeschraubt/gear screwed on/pignon vissé/rueda dentada atornillada/зубчатое колесо привинчено					
	[12] M 28 x 60				A 352 054 05 01	<b>20 1003 35260</b>
	I [1]				A 352 050 10 33 A 366 050 04 33	<b>20 1003 36602</b> (3)
	(3) IN					

**131**
**97**
**OM 314**
**900, 910, 914 - 915, 917 - 920, 940 - 951, 954, 959, 961 - 965, 967**

01.1964 →

D (NA) 4

2V

35-66 kW

(48-90 PS)

128,00 mm

90 274 8.., 93 882 6..

Fortsetzung nächste Seite / continued on next page / suite page suivante / continuación página próxima / Продолжение на следующей странице

					Reference	Item No.	
	IN [2]	43,0 x 9 x 140,5	A/S - Cr -	- 30° - -	5 - III	A 366 050 02 26	<b>16109</b>
	IN [2]	44,0 x 9 x 140,5	A/S - Cr -	- 45° - -	5 - III	A 352 050 00 26 A 352 050 01 26 A 352 053 01 01	<b>16136</b>
	EX [2]	36,0 x 10 x 140,5	A/S - Cr -	- 45° - -	5 - III	A 366 050 02 27	<b>16122</b>
	EX [2]	36,0 x 10 x 140,5	S - Cr -	- 45° - VS -	5 - III	A 352 053 15 05	<b>1604</b>
	EX [2]	36,0 x 10 x 140,6	A/S - Cr -	- 45° - -	5 - III	A 321 053 09 05 A 366 050 00 27 A 366 050 01 27 A 366 050 05 27 A 366 050 06 27 A 376 050 00 27 A 376 050 01 27	<b>16106</b>
	IN [6]	15,00 x 9 x 78,0	G1			A 312 053 02 30	<b>81-1609</b>
	IN [6]	15,03 x 9 x 72,0	G1			A 352 053 12 29	<b>81-1666</b>
	IN [6]	15,04 x 9 x 72,0	G1			A 352 053 22 29 A 366 053 07 29	<b>81-1674</b>
	EX [6]	15,00 x 10 x 73,0	G1			A 352 053 16 30	<b>81-1658</b>
	EX [6]	15,03 x 10 x 67,0	G1			A 352 053 20 30	<b>81-1670</b>
	EX [6]	15,04 x 10 x 67,0	G1			A 352 053 37 30 A 366 053 02 30	<b>81-1676</b>
	EX [6]	15,20 x 10 x 73,0	G1			A 352 053 18 30	<b>81-1659</b>
	IN [1]	45,08 x 37 x 8,3	G1 45°			A 352 053 16 31 A 352 053 22 31 A 352 053 31 31	<b>92-16112</b>
	IN [1]	45,87 x 37 x 8,2	G1 45°			A 352 053 35 31 A 352 053 38 31 A 352 053 40 31	<b>92-16114</b>
	EX [2]	38,07 x 30 x 8,5	G1 45°			A 366 053 16 32	<b>92-16109</b>
	EX [1]	38,38 x 30 x 8,5	G1 45°			A 352 053 16 32 A 352 053 21 32	<b>92-16131</b>
	[12]	M 28 x 60				A 352 054 05 01	<b>20 1003 35260</b>
	I [1]					A 352 050 10 33 A 366 050 04 33	<b>20 1003 36602 (1)</b>
	(1) IN						

## 132 97

**OM 314** 900-000, 900-001, 900-002, 900-003, 900-004, 900-005, 900-006, 900-007, 900-008, 900-010, 900-011, 900-012, 900-013, 900-014, 900-015, 900-016, 900-017, 900-018, 900-019, 900-020, 900-021, 900-022, 900-023, 900-024, 900-025

OM 314	01.1964 → 12.1988	D	4	3780 cm <sup>3</sup>	2V	35-63 kW	(47-85 PS)	128,00 mm
OM 340	919-001	D	4	3780 cm <sup>3</sup>	2V	63 kW	(86 PS) 17:1	128,00 mm
OM 341	900-001	D	6	5675 cm <sup>3</sup>	2V	74 kW	(100 PS) 17:1	128,00 mm
OM 343	919-001	D	4	3780 cm <sup>3</sup>	2V	39 kW	(53 PS) 17:1	128,00 mm
OM 344	919-001	D	6	5675 cm <sup>3</sup>	2V	88 kW	(120 PS) 17:1	128,00 mm

90 274 8.., 93 882 6..

	[12]	M 28 x 60				A 352 054 05 01	<b>20 1003 35260</b>
--	------	-----------	--	--	--	-----------------	----------------------

					Reference	Item No.
<b>133</b>		<b>97</b>				
<b>OM 314</b>	<b>921 - 922</b>	D (NA)	4	3782 cm <sup>3</sup>	2V 48-57 kW (65-78 PS) 17:1	128,00 mm
<b>OM 352</b>	<b>913, 916, 918, 937, 946, 949 - 950, 968, 994</b>	D (A)	6	5675 cm <sup>3</sup>	2V 110-115 kW (150-156 PS) 16:1	128,00 mm
<b>OM 353</b>	<b>909 - 910</b>	01.1970 → 06.1997 D (A)	6	5675 cm <sup>3</sup>	2V 124-125 kW (168-170 PS) 16,5:1	128,00 mm
90 274 8..., 90 276 7..., 92 581 6..., 93 750 6..., 93 882 6..						
	IN [2]	44,0 x 9 x 140,5	A/S - Cr -	- 45° - -	5 - III	A 352 050 00 26 A 352 050 01 26 A 352 053 01 01 <b>16136</b>
	EX [2]	36,0 x 10 x 140,5	A/S - Cr -	- 45° - -	5 - III	A 366 050 02 27 <b>16122</b>
	EX [2]	36,0 x 10 x 140,5	S - Cr -	- 45° - VS -	5 - III	A 352 053 15 05 <b>1604</b>
	EX [2]	36,0 x 10 x 140,6	A/S - Cr -	- 45° - -	5 - III	A 321 053 09 05 A 366 050 00 27 A 366 050 01 27 A 366 050 05 27 A 366 050 06 27 A 376 050 00 27 A 376 050 01 27 <b>16106</b>
	IN [6]	15,00 x 9 x 78,0	G1			A 312 053 02 30 <b>81-1609</b>
	IN [6]	15,03 x 9 x 72,0	G1			A 352 053 12 29 <b>81-1666</b>
	IN [6]	15,04 x 9 x 72,0	G1			A 352 053 22 29 A 366 053 07 29 <b>81-1674</b>
	EX [6]	15,00 x 10 x 73,0	G1			A 352 053 16 30 <b>81-1658</b>
	EX [6]	15,00 x 10 x 78,0	G1			A 321 053 12 30 <b>81-1631</b>
	EX [6]	15,03 x 10 x 67,0	G1			A 352 053 20 30 <b>81-1670</b>
	EX [6]	15,04 x 10 x 67,0	G1			A 352 053 37 30 A 366 053 02 30 <b>81-1676</b>
	EX [6]	15,10 x 10 x 78,0	G1			A 321 053 13 30 <b>81-1632</b>
	EX [6]	15,20 x 10 x 73,0	G1			A 352 053 18 30 <b>81-1659</b>
	IN [1]	45,08 x 37 x 8,3	G1 45°			A 352 053 16 31 A 352 053 22 31 A 352 053 31 31 <b>92-16112</b>
	IN [1]	45,87 x 37 x 8,2	G1 45°			A 352 053 35 31 A 352 053 38 31 A 352 053 40 31 <b>92-16114</b>
	EX [2]	38,07 x 30 x 8,5	G1 45°			A 366 053 16 32 <b>92-16109</b>
	EX [1]	38,38 x 30 x 8,5	G1 45°			A 352 053 16 32 A 352 053 21 32 <b>92-16131</b>
	[12]	M 28 x 60				A 352 054 05 01 <b>20 1003 35260</b>
	I [1]					A 352 050 10 33 A 366 050 04 33 <b>20 1003 36602 (1)</b>
	(1) IN					
<b>134</b>		<b>97</b>				
<b>OM 344</b>	<b>991, 997</b>	01.1964 →	D	6	5675 cm <sup>3</sup> 2V 96 kW (130 PS) 17:1	128,00 mm
<b>OM 344</b>	<b>905, 912, 946, 963</b>		D (NA)	6	5675 cm <sup>3</sup> 2V 96 kW (131 PS) 17:1	128,00 mm
<b>OM 344</b>	<b>940 - 941</b>		D (A)	6	5675 cm <sup>3</sup> 2V 96 kW (131 PS) 17:1	128,00 mm
90 274 8..., 93 882 6..						
Fortsetzung nächste Seite / continued on next page / suite page suivante / continuación página próxima / Продолжение на следующей странице						

					Reference	Item No.	
	IN [2]	43,0 x 9 x 140,5	A/S - Cr -	- 30° - -	5 - III	A 366 050 02 26	<b>16109</b>
	IN [2]	44,0 x 9 x 140,5	A/S - Cr -	- 45° - -	5 - III	A 352 050 00 26	<b>16136</b>
						A 352 050 01 26	
						A 352 053 01 01	
	EX [2]	36,0 x 10 x 140,5	A/S - Cr -	- 45° - -	5 - III	A 366 050 02 27	<b>16122</b>
	EX [2]	36,0 x 10 x 140,5	S - Cr -	- 45° - VS -	5 - III	A 352 053 15 05	<b>1604</b>
	EX [2]	36,0 x 10 x 140,6	A/S - Cr -	- 45° - -	5 - III	A 321 053 09 05	<b>16106</b>
						A 366 050 00 27	
						A 366 050 01 27	
						A 366 050 05 27	
					A 366 050 06 27		
					A 376 050 00 27		
					A 376 050 01 27		
	IN [6]	15,00 x 9 x 78,0	G1			A 312 053 02 30	<b>81-1609</b>
	IN [6]	15,03 x 9 x 72,0	G1			A 352 053 12 29	<b>81-1666</b>
	IN [6]	15,04 x 9 x 72,0	G1			A 352 053 22 29	<b>81-1674</b>
						A 366 053 07 29	
	EX [6]	15,00 x 10 x 73,0	G1			A 352 053 16 30	<b>81-1658</b>
	EX [6]	15,03 x 10 x 67,0	G1			A 352 053 20 30	<b>81-1670</b>
	EX [6]	15,04 x 10 x 67,0	G1			A 352 053 37 30	<b>81-1676</b>
						A 366 053 02 30	
	EX [6]	15,20 x 10 x 73,0	G1			A 352 053 18 30	<b>81-1659</b>
		IN [1]	45,08 x 37 x 8,3	G1 45°			A 352 053 16 31
						A 352 053 22 31	
						A 352 053 31 31	
IN [1]		45,87 x 37 x 8,2	G1 45°			A 352 053 35 31	<b>92-16114</b>
						A 352 053 38 31	
						A 352 053 40 31	
EX [2]	38,07 x 30 x 8,5	G1 45°			A 366 053 16 32	<b>92-16109</b>	
EX [1]	38,38 x 30 x 8,5	G1 45°			A 352 053 16 32	<b>92-16131</b>	
					A 352 053 21 32		
		739 mm				A 352 050 49 01	<b>20 1003 35201 (1)</b>
		(1) Zahnrad angeschraubt/gear screwed on/pignon vissé/rueda dentada atornillada/зубчатое колесо привинчено					
	[12]	M 28 x 60				A 352 054 05 01	<b>20 1003 35260</b>

## 135 97

OM 352

900-000, 900-001, 900-002, 900-003, 900-004, 900-005, 900-007, 900-009, 900-011, 900-012, 900-014, 900-016, 900-017, 900-018, 900-019, 900-020, 900-021

D 6 5675 cm<sup>3</sup> 2V 66-96 kW (90-130 PS) 128,00 mm

OM 352

900-006, 900-008, 900-010, 900-013, 900-015, 900-400, 900-410, 900-411, 900-412, 900-413, 900-414, 900-415, 900-416, 900-417, 900-418, 900-419, 900-420, 900-421, 900-422, 900-423, 900-424, 900-425, 900-426, 900-427, 900-428, 900-429, 900-430

06.1982 → 11.1987 D (A) 6 5675 cm<sup>3</sup> 2V 99-124 kW (135-168 PS) 128,00 mm

90 274 8..., 90 276 7..., 92 581 6..., 93 750 6..., 93 882 6..

		739 mm				A 352 050 44 01	<b>20 1003 35200 (1)</b>
		739 mm				A 352 050 49 01	<b>20 1003 35201 (2)</b>
		(1) Zahnrad aufgeschumpft/gear shrunked on/pignon emmanché/rueda dentada zunchada/зубчатое колесо запрессовано на горячую					
		(2) Zahnrad angeschraubt/gear screwed on/pignon vissé/rueda dentada atornillada/зубчатое колесо привинчено					
	[12]	M 28 x 60				A 352 054 05 01	<b>20 1003 35260</b>



					Reference	Item No.
--	--	--	--	--	-----------	----------

<b>136</b>		<b>97</b>					
<b>OM 314</b>	<b>916, 953</b>						
	04.1966 →	D (NA)	4	3780 cm <sup>3</sup>	2V	40-59 kW (54-80 PS) 17:1	128,00 mm
<b>OM 352</b>	<b>919</b>						
	01.1965 → 04.1966	D (NA)	6	5675 cm <sup>3</sup>	2V	48 kW (65 PS) 17:1	128,00 mm
90 274 8.., 93 882 6..							

	IN [2]	44,0 x 9 x 140,5	A/S - Cr -	- 45° -	-	5 - III	A 352 050 00 26 A 352 050 01 26 A 352 053 01 01	<b>16136</b>
	EX [2]	36,0 x 10 x 140,5	A/S - Cr -	- 45° -	-	5 - III	A 366 050 02 27	<b>16122</b>
	EX [2]	36,0 x 10 x 140,5	S - Cr -	- 45° -	VS -	5 - III	A 352 053 15 05	<b>1604</b>
	EX [2]	36,0 x 10 x 140,6	A/S - Cr -	- 45° -	-	5 - III	A 321 053 09 05 A 366 050 00 27 A 366 050 01 27 A 366 050 05 27 A 366 050 06 27 A 376 050 00 27 A 376 050 01 27	<b>16106</b>
	IN [6]	15,00 x 9 x 78,0	G1				A 312 053 02 30	<b>81-1609</b>
	IN [6]	15,03 x 9 x 72,0	G1				A 352 053 12 29	<b>81-1666</b>
	IN [6]	15,04 x 9 x 72,0	G1				A 352 053 22 29	<b>81-1674</b>
	EX [6]	15,00 x 10 x 73,0	G1				A 366 053 07 29	<b>81-1658</b>
	EX [6]	15,03 x 10 x 67,0	G1				A 352 053 16 30	<b>81-1670</b>
	EX [6]	15,04 x 10 x 67,0	G1				A 352 053 20 30	<b>81-1676</b>
	EX [6]	15,04 x 10 x 67,0	G1				A 352 053 37 30	<b>81-1676</b>
	EX [6]	15,20 x 10 x 73,0	G1				A 366 053 02 30 A 352 053 18 30	<b>81-1659</b>
	IN [1]	45,08 x 37 x 8,3	G1 45°				A 352 053 16 31 A 352 053 22 31 A 352 053 31 31	<b>92-16112</b>
	IN [1]	45,87 x 37 x 8,2	G1 45°				A 352 053 35 31 A 352 053 38 31 A 352 053 40 31	<b>92-16114</b>
	EX [2]	38,07 x 30 x 8,5	G1 45°				A 366 053 16 32	<b>92-16109</b>
	EX [1]	38,38 x 30 x 8,5	G1 45°				A 352 053 16 32 A 352 053 21 32	<b>92-16131</b>
	[12]	M 28 x 60					A 352 054 05 01	<b>20 1003 35260</b>
	I [1]						A 352 050 10 33 A 366 050 04 33	<b>20 1003 36602 (1)</b>
	(1) IN							

<b>137</b>		<b>97</b>					
<b>OM 341</b>	<b>910 - 912, 915, 919, 931 - 932, 935 - 936, 938, 941, 946, 949, 995</b>						
		D (NA)	6	5675 cm <sup>3</sup>	2V	66-96 kW (90-131 PS) 17:1	128,00 mm
<b>OM 344</b>	<b>933, 944</b>						
	01.1975 →	D (NA)	6	5675 cm <sup>3</sup>	2V	96 kW (131 PS) 17:1	128,00 mm
90 274 8.., 93 882 6..							

Fortsetzung nächste Seite / continued on next page / suite page suivante / continuación página próxima / Продолжение на следующей странице							

					Reference	Item No.
	IN [2] 44,0 x 9 x 140,5	A/S - Cr -	- 45° - -	5 - III	A 352 050 00 26 A 352 050 01 26 A 352 053 01 01	<b>16136</b>
	EX [2] 36,0 x 10 x 140,5	A/S - Cr -	- 45° - -	5 - III	A 366 050 02 27	<b>16122</b>
	EX [2] 36,0 x 10 x 140,5	S - Cr -	- 45° - VS -	5 - III	A 352 053 15 05	<b>1604</b>
	EX [2] 36,0 x 10 x 140,6	A/S - Cr -	- 45° - -	5 - III	A 321 053 09 05 A 366 050 00 27 A 366 050 01 27 A 366 050 05 27 A 366 050 06 27 A 376 050 00 27 A 376 050 01 27	<b>16106</b>
	IN [6] 15,00 x 9 x 78,0	G1			A 312 053 02 30	<b>81-1609</b>
	IN [6] 15,04 x 9 x 72,0	G1			A 352 053 22 29 A 366 053 07 29	<b>81-1674</b>
	EX [6] 15,00 x 10 x 73,0	G1			A 352 053 16 30	<b>81-1658</b>
	EX [6] 15,04 x 10 x 67,0	G1			A 352 053 37 30 A 366 053 02 30	<b>81-1676</b>
	EX [6] 15,20 x 10 x 73,0	G1			A 352 053 18 30	<b>81-1659</b>
	IN [1] 45,08 x 37 x 8,3	G1 45°			A 352 053 16 31 A 352 053 22 31 A 352 053 31 31	<b>92-16112</b>
	IN [1] 45,87 x 37 x 8,2	G1 45°			A 352 053 35 31 A 352 053 38 31 A 352 053 40 31	<b>92-16114</b>
	EX [2] 38,07 x 30 x 8,5	G1 45°			A 366 053 16 32	<b>92-16109</b>
	EX [1] 38,38 x 30 x 8,5	G1 45°			A 352 053 16 32 A 352 053 21 32	<b>92-16131</b>
	739 mm				A 352 050 49 01	<b>20 1003 35201 (1)</b>
	(1) Zahnrad angeschraubt/gear screwed on/pignon vissé/rueda dentada atornillada/зубчатое колесо привинчено					
	[12] M 28 x 60				A 352 054 05 01	<b>20 1003 35260</b>

M

**138**

**97**

OM 341

918

D (NA) 6 5675 cm<sup>3</sup> 2V 66 kW (90 PS) 17:1 128,00 mm

90 274 8.., 93 882 6..

	IN [2] 44,0 x 9 x 140,5	A/S - Cr -	- 45° - -	5 - III	A 352 050 00 26 A 352 050 01 26 A 352 053 01 01	<b>16136</b>
	EX [2] 36,0 x 10 x 140,5	A/S - Cr -	- 45° - -	5 - III	A 366 050 02 27	<b>16122</b>
	EX [2] 36,0 x 10 x 140,5	S - Cr -	- 45° - VS -	5 - III	A 352 053 15 05	<b>1604</b>
	EX [2] 36,0 x 10 x 140,6	A/S - Cr -	- 45° - -	5 - III	A 321 053 09 05 A 366 050 00 27 A 366 050 01 27 A 366 050 05 27 A 366 050 06 27 A 376 050 00 27 A 376 050 01 27	<b>16106</b>
	IN [6] 15,00 x 9 x 78,0	G1			A 312 053 02 30	<b>81-1609</b>
	IN [6] 15,04 x 9 x 72,0	G1			A 352 053 22 29 A 366 053 07 29	<b>81-1674</b>
	EX [6] 15,00 x 10 x 73,0	G1			A 352 053 16 30	<b>81-1658</b>
	EX [6] 15,04 x 10 x 67,0	G1			A 352 053 37 30 A 366 053 02 30	<b>81-1676</b>
	EX [6] 15,20 x 10 x 73,0	G1			A 352 053 18 30	<b>81-1659</b>

Fortsetzung nächste Seite / continued on next page / suite page suivante / continuación página próxima / Продолжение на следующей странице

					Reference	Item No.
IN [1]	45,08 x 37 x 8,3	G1 45°			A 352 053 16 31 A 352 053 22 31 A 352 053 31 31	<b>92-16112</b>
IN [1]	45,87 x 37 x 8,2	G1 45°			A 352 053 35 31 A 352 053 38 31 A 352 053 40 31	<b>92-16114</b>
EX [2]	38,07 x 30 x 8,5	G1 45°			A 366 053 16 32	<b>92-16109</b>
EX [1]	38,38 x 30 x 8,5	G1 45°			A 352 053 16 32 A 352 053 21 32	<b>92-16131</b>
[12]	M 28 x 60				A 352 054 05 01	<b>20 1003 35260</b>

**139**
**97**
**OM 353**
**949, 981 - 984**

03.1973 →

D (NA) 6

 5675 cm<sup>3</sup>

2V

81-96 kW

(110-130 PS) 17:1

128,00 mm

90 274 8..., 93 882 6..

IN [2]	44,0 x 9 x 140,5	A/S - Cr -	- 45° - -	5 - III	A 352 050 00 26 A 352 050 01 26 A 352 053 01 01	<b>16136</b>
EX [2]	36,0 x 10 x 140,5	A/S - Cr -	- 45° - -	5 - III	A 366 050 02 27	<b>16122</b>
EX [2]	36,0 x 10 x 140,5	S - Cr -	- 45° - VS -	5 - III	A 352 053 15 05	<b>1604</b>
EX [2]	36,0 x 10 x 140,6	A/S - Cr -	- 45° - -	5 - III	A 321 053 09 05 A 366 050 00 27 A 366 050 01 27 A 366 050 05 27 A 366 050 06 27 A 376 050 00 27 A 376 050 01 27	<b>16106</b>
IN [6]	15,00 x 9 x 78,0	G1			A 312 053 02 30	<b>81-1609</b>
IN [6]	15,03 x 9 x 72,0	G1			A 352 053 12 29	<b>81-1666</b>
IN [6]	15,04 x 9 x 72,0	G1			A 352 053 22 29 A 366 053 07 29	<b>81-1674</b>
EX [6]	15,00 x 10 x 73,0	G1			A 352 053 16 30	<b>81-1658</b>
EX [6]	15,03 x 10 x 67,0	G1			A 352 053 20 30	<b>81-1670</b>
EX [6]	15,04 x 10 x 67,0	G1			A 352 053 37 30 A 366 053 02 30	<b>81-1676</b>
EX [6]	15,20 x 10 x 73,0	G1			A 352 053 18 30	<b>81-1659</b>
IN [1]	45,08 x 37 x 8,3	G1 45°			A 352 053 16 31 A 352 053 22 31 A 352 053 31 31	<b>92-16112</b>
IN [1]	45,87 x 37 x 8,2	G1 45°			A 352 053 35 31 A 352 053 38 31 A 352 053 40 31	<b>92-16114</b>
EX [2]	38,07 x 30 x 8,5	G1 45°			A 366 053 16 32	<b>92-16109</b>
EX [1]	38,38 x 30 x 8,5	G1 45°			A 352 053 16 32 A 352 053 21 32	<b>92-16131</b>
	739 mm				A 352 050 49 01	<b>20 1003 35201 (1)</b>
	(1) Zahnrad angeschraubt/gear screwed on/pignon vissé/rueda dentada atornillada/зубчатое колесо привинчено					
[12]	M 28 x 60				A 352 054 05 01	<b>20 1003 35260</b>
I [1]					A 352 050 10 33 A 366 050 04 33	<b>20 1003 36602 (2)</b>
	(2) IN					

**M**

					Reference	Item No.	
<b>140</b>		<b>97</b>	<b>OM 344</b> <b>931, 948, 952</b> 01.1970 →      D (A) 6 5675 cm <sup>3</sup> 2V 115-124 kW (156-169 PS) 16:1 128,00 mm 90 276 7..., 92 581 6..				
	IN [2] IN [2] IN [2]	42,0 x 9 x 140,5 43,0 x 9 x 140,5 44,0 x 9 x 140,5	A/S - Cr - A/S - Cr - A/S - Cr -	- 30° - - - 30° - - - 45° - -	5 - III 5 - III 5 - III	A 366 050 03 26 A 366 050 02 26 A 352 050 00 26 A 352 050 01 26 A 352 053 01 01 A 366 050 02 27 A 352 053 15 05 A 321 053 09 05 A 366 050 00 27 A 366 050 01 27 A 366 050 05 27 A 366 050 06 27 A 376 050 00 27 A 376 050 01 27	<b>16130</b> <b>16109</b> <b>16136</b>  <b>16122</b> <b>1604</b> <b>16106</b>
	EX [2] EX [2] EX [2]	36,0 x 10 x 140,5 36,0 x 10 x 140,5 36,0 x 10 x 140,6	A/S - Cr - S - Cr - A/S - Cr -	- 45° - - - 45° - VS - - 45° - -	5 - III 5 - III 5 - III	A 366 050 02 27 A 352 053 15 05 A 321 053 09 05 A 366 050 00 27 A 366 050 01 27 A 366 050 05 27 A 366 050 06 27 A 376 050 00 27 A 376 050 01 27	<b>16122</b> <b>1604</b> <b>16106</b>
	IN [6] IN [6]	15,00 x 9 x 78,0 15,04 x 9 x 72,0	G1 G1			A 312 053 02 30 A 352 053 22 29 A 366 053 07 29	<b>81-1609</b> <b>81-1674</b>
	EX [6] EX [6]	15,00 x 10 x 73,0 15,04 x 10 x 67,0	G1 G1			A 352 053 16 30 A 352 053 37 30 A 366 053 02 30	<b>81-1658</b> <b>81-1676</b>
	EX [6]	15,20 x 10 x 73,0	G1			A 352 053 18 30	<b>81-1659</b>
	IN [1] IN [1]	45,08 x 37 x 8,3 45,87 x 37 x 8,2	G1 45° G1 45°			A 352 053 16 31 A 352 053 22 31 A 352 053 31 31 A 352 053 35 31 A 352 053 38 31 A 352 053 40 31	<b>92-16112</b>  <b>92-16114</b>
	EX [2] EX [1]	38,07 x 30 x 8,5 38,38 x 30 x 8,5	G1 45° G1 45°			A 366 053 16 32 A 352 053 16 32 A 352 053 21 32	<b>92-16109</b> <b>92-16131</b>
	[12]	M 28 x 60				A 352 054 05 01	<b>20 1003 35260</b>
<b>141</b>		<b>97</b>	<b>OM 353</b> <b>911 - 914, 950 - 953, 970 - 972, 977 - 978, 991, 997</b> 01.1971 →      D (A) 6 5675 cm <sup>3</sup> 2V 124-127 kW (168-172 PS) 128,00 mm 90 276 7..., 92 581 6..				
	IN [2]	44,0 x 9 x 140,5	A/S - Cr -	- 45° - -	5 - III	A 352 050 00 26 A 352 050 01 26 A 352 053 01 01	<b>16136</b>
	EX [2] EX [2] EX [2]	36,0 x 10 x 140,5 36,0 x 10 x 140,5 36,0 x 10 x 140,6	A/S - Cr - S - Cr - A/S - Cr -	- 45° - - - 45° - VS - - 45° - -	5 - III 5 - III 5 - III	A 366 050 02 27 A 352 053 15 05 A 321 053 09 05 A 366 050 00 27 A 366 050 01 27 A 366 050 05 27 A 366 050 06 27 A 376 050 00 27 A 376 050 01 27	<b>16122</b> <b>1604</b> <b>16106</b>
Fortsetzung nächste Seite / continued on next page / suite page suivante / continuación página próxima / Продолжение на следующей странице							

					Reference	Item No.
	IN [6]	15,00 x 9 x 78,0	G1		A 312 053 02 30	<b>81-1609</b>
	IN [6]	15,03 x 9 x 72,0	G1		A 352 053 12 29	<b>81-1666</b>
	IN [6]	15,04 x 9 x 72,0	G1		A 352 053 22 29	<b>81-1674</b>
					A 366 053 07 29	
	EX [6]	15,00 x 10 x 73,0	G1		A 352 053 16 30	<b>81-1658</b>
	EX [6]	15,00 x 10 x 78,0	G1		A 321 053 12 30	<b>81-1631</b>
	EX [6]	15,03 x 10 x 67,0	G1		A 352 053 20 30	<b>81-1670</b>
	EX [6]	15,04 x 10 x 67,0	G1		A 352 053 37 30	<b>81-1676</b>
				A 366 053 02 30		
	EX [6]	15,10 x 10 x 78,0	G1		A 321 053 13 30	<b>81-1632</b>
	EX [6]	15,20 x 10 x 73,0	G1		A 352 053 18 30	<b>81-1659</b>
	IN [1]	45,08 x 37 x 8,3	G1 45°		A 352 053 16 31	<b>92-16112</b>
					A 352 053 22 31	
	IN [1]	45,87 x 37 x 8,2	G1 45°		A 352 053 31 31	<b>92-16114</b>
					A 352 053 35 31	
	EX [2]	38,07 x 30 x 8,5	G1 45°		A 352 053 38 31	<b>92-16109</b>
	EX [1]	38,38 x 30 x 8,5	G1 45°		A 352 053 40 31	
					A 366 053 16 32	<b>92-16131</b>
					A 352 053 16 32	
					A 352 053 21 32	
		739 mm			A 352 050 50 01	<b>20 1003 35202 (1)</b>
		(1) Zahnrad angeschraubt/gear screwed on/pignon vissé/rueda dentada atornillada/зубчатое колесо привинчено				
	[12]	M 28 x 60			A 352 054 05 01	<b>20 1003 35260</b>
	I [1]				A 352 050 10 33	<b>20 1003 36602 (2)</b>
					A 366 050 04 33	
		(2) IN				

## 142 97

OM 341

**913, 996**

06.1973→

D (A) 6 5675 cm<sup>3</sup> 2V 115-118 kW (156-160 PS) 17:1 128,00 mm

OM 341

**934**

D (NA) 6 5675 cm<sup>3</sup> 2V 62 kW (84 PS) 17:1 128,00 mm

90 274 8.., 90 276 7.., 92 581 6.., 93 882 6..

	IN [2]	43,0 x 9 x 140,5	A/S - Cr -	- 30° - -	5 - III	A 366 050 02 26	<b>16109</b>
	IN [2]	44,0 x 9 x 140,5	A/S - Cr -	- 45° - -	5 - III	A 352 050 00 26	<b>16136</b>
						A 352 050 01 26	
						A 352 053 01 01	
	EX [2]	36,0 x 10 x 140,5	A/S - Cr -	- 45° - -	5 - III	A 366 050 02 27	<b>16122</b>
	EX [2]	36,0 x 10 x 140,5	S - Cr -	- 45° - VS -	5 - III	A 352 053 15 05	<b>1604</b>
	EX [2]	36,0 x 10 x 140,6	A/S - Cr -	- 45° - -	5 - III	A 321 053 09 05	<b>16106</b>
						A 366 050 00 27	
						A 366 050 01 27	
						A 366 050 05 27	
						A 366 050 06 27	
						A 376 050 00 27	
						A 376 050 01 27	
	IN [6]	15,00 x 9 x 78,0	G1			A 312 053 02 30	<b>81-1609</b>
	IN [6]	15,04 x 9 x 72,0	G1			A 352 053 22 29	<b>81-1674</b>
						A 366 053 07 29	
	EX [6]	15,00 x 10 x 73,0	G1			A 352 053 16 30	<b>81-1658</b>
	EX [6]	15,04 x 10 x 67,0	G1			A 352 053 37 30	<b>81-1676</b>
						A 366 053 02 30	
	EX [6]	15,20 x 10 x 73,0	G1			A 352 053 18 30	<b>81-1659</b>

Fortsetzung nächste Seite / continued on next page / suite page suivante / continuación página próxima / Продолжение на следующей странице



					Reference	Item No.
IN [1]	45,08 x 37 x 8,3	G1 45°			A 352 053 16 31 A 352 053 22 31 A 352 053 31 31	<b>92-16112</b>
IN [1]	45,87 x 37 x 8,2	G1 45°			A 352 053 35 31 A 352 053 38 31 A 352 053 40 31	<b>92-16114</b>
EX [2]	38,07 x 30 x 8,5	G1 45°			A 366 053 16 32	<b>92-16109</b>
EX [1]	38,38 x 30 x 8,5	G1 45°			A 352 053 16 32 A 352 053 21 32	<b>92-16131</b>
[12]	M 28 x 60				A 352 054 05 01	<b>20 1003 35260</b>

## 143 97

OM 341

937, 939, 943

06.1973 →

D

(A)

6

5675 cm<sup>3</sup> 2V

96-115 kW

(131-156 PS) 17:1

128,00 mm

OM 341

947

06.1973 →

D

(NA)

6

5675 cm<sup>3</sup> 2V

96 kW

(131 PS) 17:1

128,00 mm

90 276 7.., 92 581 6..

IN [2]	43,0 x 9 x 140,5	A/S - Cr -	- 30° - -	5 - III	A 366 050 02 26	<b>16109</b>
IN [2]	44,0 x 9 x 140,5	A/S - Cr -	- 45° - -	5 - III	A 352 050 00 26 A 352 050 01 26 A 352 053 01 01	<b>16136</b>
EX [2]	36,0 x 10 x 140,5	A/S - Cr -	- 45° - -	5 - III	A 366 050 02 27	<b>16122</b>
EX [2]	36,0 x 10 x 140,5	S - Cr -	- 45° - VS -	5 - III	A 352 053 15 05	<b>1604</b>
EX [2]	36,0 x 10 x 140,6	A/S - Cr -	- 45° - -	5 - III	A 321 053 09 05 A 366 050 00 27 A 366 050 01 27 A 366 050 05 27 A 366 050 06 27 A 376 050 00 27 A 376 050 01 27	<b>16106</b>
IN [6]	15,00 x 9 x 78,0	G1			A 312 053 02 30	<b>81-1609</b>
IN [6]	15,04 x 9 x 72,0	G1			A 352 053 22 29 A 366 053 07 29	<b>81-1674</b>
EX [6]	15,00 x 10 x 73,0	G1			A 352 053 16 30	<b>81-1658</b>
EX [6]	15,04 x 10 x 67,0	G1			A 352 053 37 30 A 366 053 02 30	<b>81-1676</b>
EX [6]	15,20 x 10 x 73,0	G1			A 352 053 18 30	<b>81-1659</b>
IN [1]	43,87 x 34.5 x 7,8	G1 30°			A 366 053 09 31 A 366 053 12 31 A 366 053 14 31	<b>92-16153</b>
IN [1]	44,17 x 34.5 x 7,8	G1 30°			A 366 053 10 31	<b>92-16116</b>
IN [1]	45,08 x 37 x 8,3	G1 45°			A 352 053 16 31 A 352 053 22 31 A 352 053 31 31	<b>92-16112</b>
IN [1]	45,87 x 37 x 8,2	G1 45°			A 352 053 35 31 A 352 053 38 31 A 352 053 40 31	<b>92-16114</b>
EX [2]	38,07 x 30 x 8,5	G1 45°			A 366 053 16 32	<b>92-16109</b>
EX [1]	38,38 x 30 x 8,5	G1 45°			A 352 053 16 32 A 352 053 21 32	<b>92-16131</b>
	739 mm				A 352 050 50 01	<b>20 1003 35202 (1)</b>
	(1) Zahnrad angeschraubt/gear screwed on/pignon vissé/rueda dentada atornillada/зубчатое колесо привинчено					
[12]	M 28 x 60				A 352 054 05 01	<b>20 1003 35260</b>

					Reference	Item No.		
<b>144</b>		<b>97</b>	<b>OM 344</b> <b>913, 934, 937 - 939, 951, 953 - 955</b> 06.1973 →      D (A)    6    5675 cm <sup>3</sup> 2V    115-124 kW    (156-168 PS)      128,00 mm 90 276 7..., 92 581 6..., 93 750 6..					
	IN [2] IN [2] IN [2]	42,0 x 9 x 140,5 43,0 x 9 x 140,5 44,0 x 9 x 140,5	A/S - Cr - A/S - Cr - A/S - Cr -	- 30° - - 30° - - 45° -	- - -	5 - III 5 - III 5 - III	A 366 050 03 26 A 366 050 02 26 A 352 050 00 26 A 352 050 01 26 A 352 053 01 01 A 366 050 02 27 A 352 053 15 05 A 321 053 09 05 A 366 050 00 27 A 366 050 01 27 A 366 050 05 27 A 366 050 06 27 A 376 050 00 27 A 376 050 01 27	<b>16130</b> <b>16109</b> <b>16136</b>  <b>16122</b> <b>1604</b> <b>16106</b>
	EX [2] EX [2] EX [2]	36,0 x 10 x 140,5 36,0 x 10 x 140,5 36,0 x 10 x 140,6	A/S - Cr - S - Cr - A/S - Cr -	- 45° - - 45° - VS - - 45° -	- - -	5 - III 5 - III 5 - III	A 366 050 02 27 A 352 053 15 05 A 321 053 09 05 A 366 050 00 27 A 366 050 01 27 A 366 050 05 27 A 366 050 06 27 A 376 050 00 27 A 376 050 01 27	<b>16122</b> <b>1604</b> <b>16106</b>
	IN [6] IN [6]	15,00 x 9 x 78,0 15,04 x 9 x 72,0	G1 G1				A 312 053 02 30 A 352 053 22 29 A 366 053 07 29	<b>81-1609</b> <b>81-1674</b>
	EX [6] EX [6]	15,00 x 10 x 73,0 15,04 x 10 x 67,0	G1 G1				A 352 053 16 30 A 352 053 37 30 A 366 053 02 30	<b>81-1658</b> <b>81-1676</b>
	EX [6]	15,20 x 10 x 73,0	G1				A 352 053 18 30	<b>81-1659</b>
	IN [1] IN [1]	45,08 x 37 x 8,3 45,87 x 37 x 8,2	G1 45° G1 45°				A 352 053 16 31 A 352 053 22 31 A 352 053 31 31 A 352 053 35 31 A 352 053 38 31 A 352 053 40 31	<b>92-16112</b> <b>92-16114</b>
	EX [2] EX [1]	38,07 x 30 x 8,5 38,38 x 30 x 8,5	G1 45° G1 45°				A 366 053 16 32 A 352 053 16 32 A 352 053 21 32	<b>92-16109</b> <b>92-16131</b>
		739 mm					A 366 050 04 01 A 366 050 06 01 A 366 051 11 01	<b>20 1003 36601</b>
	[12]	M 28 x 60					A 352 054 05 01	<b>20 1003 35260</b>
<b>145</b>		<b>97</b>	<b>OM 344</b> <b>942 (USA)</b> 06.1973 →      D (A)    6    5675 cm <sup>3</sup> 2V    115 kW    (156 PS) 16:1      128,00 mm 93 750 6..					
	IN [2] IN [2]	43,0 x 9 x 140,5 44,0 x 9 x 140,5	A/S - Cr - A/S - Cr -	- 30° - - 45° -	- -	5 - III 5 - III	A 366 050 02 26 A 352 050 00 26 A 352 050 01 26 A 352 053 01 01 A 366 050 02 27 A 352 053 15 05 A 321 053 09 05 A 366 050 00 27 A 366 050 01 27 A 366 050 05 27 A 366 050 06 27 A 376 050 00 27 A 376 050 01 27	<b>16109</b> <b>16136</b>  <b>16122</b> <b>1604</b> <b>16106</b>
	EX [2] EX [2] EX [2]	36,0 x 10 x 140,5 36,0 x 10 x 140,5 36,0 x 10 x 140,6	A/S - Cr - S - Cr - A/S - Cr -	- 45° - - 45° - VS - - 45° -	- - -	5 - III 5 - III 5 - III	A 366 050 02 27 A 352 053 15 05 A 321 053 09 05 A 366 050 00 27 A 366 050 01 27 A 366 050 05 27 A 366 050 06 27 A 376 050 00 27 A 376 050 01 27	<b>16122</b> <b>1604</b> <b>16106</b>
Fortsetzung nächste Seite / continued on next page / suite page suivante / continuación página próxima / Продолжение на следующей странице								

M

					Reference	Item No.	
	IN [6]	15,00 x 9 x 78,0	G1		A 312 053 02 30	<b>81-1609</b>	
	IN [6]	15,03 x 9 x 72,0	G1		A 352 053 12 29	<b>81-1666</b>	
	IN [6]	15,04 x 9 x 72,0	G1		A 352 053 22 29	<b>81-1674</b>	
					A 366 053 07 29		
	EX [6]	15,00 x 10 x 73,0	G1		A 352 053 16 30	<b>81-1658</b>	
	EX [6]	15,03 x 10 x 67,0	G1		A 352 053 20 30	<b>81-1670</b>	
				A 352 053 37 30	<b>81-1676</b>		
	EX [6]	15,20 x 10 x 73,0	G1		A 366 053 02 30		
					A 352 053 18 30	<b>81-1659</b>	
	IN [1]	45,08 x 37 x 8,3	G1 45°		A 352 053 16 31	<b>92-16112</b>	
					A 352 053 22 31		
					A 352 053 31 31		
	IN [1]	45,87 x 37 x 8,2	G1 45°		A 352 053 35 31	<b>92-16114</b>	
					A 352 053 38 31		
					A 352 053 40 31		
	EX [2]	38,07 x 30 x 8,5	G1 45°		A 366 053 16 32	<b>92-16109</b>	
	EX [1]	38,38 x 30 x 8,5	G1 45°		A 352 053 16 32	<b>92-16131</b>	
					A 352 053 21 32		
		739 mm			A 366 050 04 01	<b>20 1003 36601</b>	
					A 366 050 06 01		
					A 366 051 11 01		
	[12]	M 28 x 60			A 352 054 05 01	<b>20 1003 35260</b>	
<b>146</b>		<b>97</b>					
<b>OM 344</b>	<b>950 (USA)</b>	<b>06.1973 →</b>	<b>D (A) 6</b>	<b>5675 cm³ 2V</b>	<b>125 kW</b>	<b>(168 PS) 16:1</b>	<b>128,00 mm</b>
	IN [2]	42,0 x 9 x 140,5	A/S - Cr -	- 30° - -	5 - III	A 366 050 03 26	<b>16130</b>
	IN [2]	43,0 x 9 x 140,5	A/S - Cr -	- 30° - -	5 - III	A 366 050 02 26	<b>16109</b>
	IN [2]	44,0 x 9 x 140,5	A/S - Cr -	- 45° - -	5 - III	A 352 050 00 26	<b>16136</b>
						A 352 050 01 26	
						A 352 053 01 01	
	EX [2]	36,0 x 10 x 140,5	A/S - Cr -	- 45° - -	5 - III	A 366 050 02 27	<b>16122</b>
EX [2]	36,0 x 10 x 140,5	S - Cr -	- 45° - VS -	5 - III	A 352 053 15 05	<b>1604</b>	
EX [2]	36,0 x 10 x 140,6	A/S - Cr -	- 45° - -	5 - III	A 321 053 09 05	<b>16106</b>	
					A 366 050 00 27		
					A 366 050 01 27		
					A 366 050 05 27		
					A 366 050 06 27		
					A 376 050 00 27		
					A 376 050 01 27		
	IN [6]	15,04 x 9 x 72,0	G1			A 352 053 22 29	<b>81-1674</b>
	EX [6]	15,04 x 10 x 67,0	G1			A 366 053 07 29	
						A 352 053 37 30	<b>81-1676</b>
						A 366 053 02 30	
	IN [1]	45,08 x 37 x 8,3	G1 45°			A 352 053 16 31	<b>92-16112</b>
						A 352 053 22 31	
						A 352 053 31 31	
	IN [1]	45,87 x 37 x 8,2	G1 45°			A 352 053 35 31	<b>92-16114</b>
						A 352 053 38 31	
						A 352 053 40 31	
	EX [2]	38,07 x 30 x 8,5	G1 45°			A 366 053 16 32	<b>92-16109</b>
	EX [1]	38,38 x 30 x 8,5	G1 45°			A 352 053 16 32	<b>92-16131</b>
						A 352 053 21 32	
		739 mm				A 366 050 04 01	<b>20 1003 36601</b>
						A 366 050 06 01	
						A 366 051 11 01	
	[12]	M 28 x 60				A 352 054 05 01	<b>20 1003 35260</b>

M

					Reference	Item No.	
<b>147</b>		<b>97</b>	<b>OM 314 956 - 957</b> 07.1973 → 12.1991 D (NA) 4 3782 cm <sup>3</sup> 2V 48-55 kW (65-75 PS) 17:1 128,00 mm 90 274 8..., 93 882 6...				
	IN [2]	44,0 x 9 x 140,5	A/S - Cr -	- 45° - -	5 - III	A 352 050 00 26 A 352 050 01 26 A 352 053 01 01	<b>16136</b>
	EX [2]	36,0 x 10 x 140,5	A/S - Cr -	- 45° - -	5 - III	A 366 050 02 27	<b>16122</b>
	EX [2]	36,0 x 10 x 140,5	S - Cr -	- 45° - VS -	5 - III	A 352 053 15 05	<b>1604</b>
	EX [2]	36,0 x 10 x 140,6	A/S - Cr -	- 45° - -	5 - III	A 321 053 09 05 A 366 050 00 27 A 366 050 01 27 A 366 050 05 27 A 366 050 06 27 A 376 050 00 27 A 376 050 01 27	<b>16106</b>
	IN [6]	15,00 x 9 x 78,0	G1			A 312 053 02 30	<b>81-1609</b>
	IN [6]	15,04 x 9 x 72,0	G1			A 352 053 22 29 A 366 053 07 29	<b>81-1674</b>
	EX [6]	15,00 x 10 x 73,0	G1			A 352 053 16 30	<b>81-1658</b>
	EX [6]	15,03 x 10 x 67,0	G1			A 352 053 20 30	<b>81-1670</b>
	EX [6]	15,04 x 10 x 67,0	G1			A 352 053 37 30 A 366 053 02 30	<b>81-1676</b>
	EX [6]	15,20 x 10 x 73,0	G1			A 352 053 18 30	<b>81-1659</b>
	IN [1]	45,08 x 37 x 8,3	G1 45°			A 352 053 16 31 A 352 053 22 31 A 352 053 31 31	<b>92-16112</b>
	IN [1]	45,87 x 37 x 8,2	G1 45°			A 352 053 35 31 A 352 053 38 31 A 352 053 40 31	<b>92-16114</b>
	EX [2]	38,07 x 30 x 8,5	G1 45°			A 366 053 16 32	<b>92-16109</b>
	EX [1]	38,38 x 30 x 8,5	G1 45°			A 352 053 16 32 A 352 053 21 32	<b>92-16131</b>
	[12]	M 28 x 60				A 352 054 05 01	<b>20 1003 35260</b>
	I [1]					A 352 050 10 33 A 366 050 04 33	<b>20 1003 36602 (1)</b>
	(1) IN						
<b>148</b>		<b>97</b>	<b>OM 394 900-005 (AFS), 900-006 (AFS), 900-007 (AFS), 900-009 (AFS)</b> D 4 3780 cm <sup>3</sup> 2V 48-63 kW (65-85 PS) 17:1 128,00 mm <b>OM 396 900-005, 900-007, 900-008 (AFS), 900-009, 900-010, 900-011, 900-012, 900-013, 900-014, 900-015, 900-016</b> (AFS), 900-020 (AFS), 900-021, 900-024, 900-026 09.1975 → D 6 5675 cm <sup>3</sup> 2V 70-92 kW (95-125 PS) 17:1 128,00 mm 90 274 8..., 93 750 6..., 93 882 6...				
	IN [2]	44,0 x 9 x 140,5	A/S - Cr -	- 45° - -	5 - III	A 352 050 00 26 A 352 050 01 26 A 352 053 01 01	<b>16136</b>
	EX [2]	36,0 x 10 x 140,5	A/S - Cr -	- 45° - -	5 - III	A 366 050 02 27	<b>16122</b>
	EX [2]	36,0 x 10 x 140,5	S - Cr -	- 45° - VS -	5 - III	A 352 053 15 05	<b>1604</b>
	EX [2]	36,0 x 10 x 140,6	A/S - Cr -	- 45° - -	5 - III	A 321 053 09 05 A 366 050 00 27 A 366 050 01 27 A 366 050 05 27 A 366 050 06 27 A 376 050 00 27 A 376 050 01 27	<b>16106</b>
Fortsetzung nächste Seite / continued on next page / suite page suivante / continuación página próxima / Продолжение на следующей странице							

					Reference	Item No.
	IN [6]	15,03 x 9 x 72,0	G1		A 352 053 12 29	<b>81-1666</b>
	IN [6]	15,04 x 9 x 72,0	G1		A 352 053 22 29 A 366 053 07 29	<b>81-1674</b>
	EX [6]	15,03 x 10 x 67,0	G1		A 352 053 20 30	<b>81-1670</b>
	EX [6]	15,04 x 10 x 67,0	G1		A 352 053 37 30 A 366 053 02 30	<b>81-1676</b>
	IN [1]	45,08 x 37 x 8,3	G1 45°		A 352 053 16 31 A 352 053 22 31 A 352 053 31 31	<b>92-16112</b>
	IN [1]	45,87 x 37 x 8,2	G1 45°		A 352 053 35 31 A 352 053 38 31 A 352 053 40 31	<b>92-16114</b>
	EX [2]	38,07 x 30 x 8,5	G1 45°		A 366 053 16 32	<b>92-16109</b>
	EX [1]	38,38 x 30 x 8,5	G1 45°		A 352 053 16 32 A 352 053 21 32	<b>92-16131</b>

**149**
**97**
**OM 341**
**933, 950**

09.1973 →

D (A)

6

 5675 cm<sup>3</sup> 2V

96 kW

(131 PS) 17:1

128,00 mm

90 276 7..., 92 581 6..

**M**

	IN [2]	43,0 x 9 x 140,5	A/S - Cr -	- 30° - -	5 - III	A 366 050 02 26	<b>16109</b>
	IN [2]	44,0 x 9 x 140,5	A/S - Cr -	- 45° - -	5 - III	A 352 050 00 26 A 352 050 01 26 A 352 053 01 01	<b>16136</b>
	EX [2]	36,0 x 10 x 140,5	A/S - Cr -	- 45° - -	5 - III	A 366 050 02 27	<b>16122</b>
	EX [2]	36,0 x 10 x 140,5	S - Cr -	- 45° - VS -	5 - III	A 352 053 15 05	<b>1604</b>
	EX [2]	36,0 x 10 x 140,6	A/S - Cr -	- 45° - -	5 - III	A 321 053 09 05	<b>16106</b>
						A 366 050 00 27 A 366 050 01 27 A 366 050 05 27 A 366 050 06 27 A 376 050 00 27 A 376 050 01 27	
	IN [6]	15,00 x 9 x 78,0	G1			A 312 053 02 30	<b>81-1609</b>
	IN [6]	15,04 x 9 x 72,0	G1			A 352 053 22 29 A 366 053 07 29	<b>81-1674</b>
	EX [6]	15,00 x 10 x 73,0	G1			A 352 053 16 30	<b>81-1658</b>
	EX [6]	15,04 x 10 x 67,0	G1			A 352 053 37 30 A 366 053 02 30	<b>81-1676</b>
	EX [6]	15,20 x 10 x 73,0	G1			A 352 053 18 30	<b>81-1659</b>
	IN [1]	45,08 x 37 x 8,3	G1 45°			A 352 053 16 31 A 352 053 22 31 A 352 053 31 31	<b>92-16112</b>
	IN [1]	45,87 x 37 x 8,2	G1 45°			A 352 053 35 31 A 352 053 38 31 A 352 053 40 31	<b>92-16114</b>
	EX [2]	38,07 x 30 x 8,5	G1 45°			A 366 053 16 32	<b>92-16109</b>
	EX [1]	38,38 x 30 x 8,5	G1 45°			A 352 053 16 32 A 352 053 21 32	<b>92-16131</b>
		739 mm				A 352 050 50 01	<b>20 1003 35202 (1)</b>
		(1) Zahnrad angeschraubt/gear screwed on/pignon vissé/rueda dentada atornillada/зубчатое колесо привинчено					
	[12]	M 28 x 60				A 352 054 05 01	<b>20 1003 35260</b>



					Reference	Item No.	
<b>150</b>	<b>97</b>						
<b>OM 352</b>	<b>988</b>						
90 276 7..., 92 581 6..	09.1973 →	D (A)	6	5675 cm <sup>3</sup> 2V	96 kW (130 PS) 16:1	128,00 mm	
	IN [2]	44,0 x 9 x 140,5	A/S - Cr -	- 45° - -	5 - III	A 352 050 00 26 A 352 050 01 26 A 352 053 01 01	<b>16136</b>
	EX [2]	36,0 x 10 x 140,5	A/S - Cr -	- 45° - -	5 - III	A 366 050 02 27	<b>16122</b>
	EX [2]	36,0 x 10 x 140,5	S - Cr -	- 45° - VS -	5 - III	A 352 053 15 05	<b>1604</b>
	EX [2]	36,0 x 10 x 140,6	A/S - Cr -	- 45° - -	5 - III	A 321 053 09 05 A 366 050 00 27 A 366 050 01 27 A 366 050 05 27 A 366 050 06 27 A 376 050 00 27 A 376 050 01 27	<b>16106</b>
	IN [6]	15,00 x 9 x 78,0	G1			A 312 053 02 30	<b>81-1609</b>
	IN [6]	15,03 x 9 x 72,0	G1			A 352 053 12 29	<b>81-1666</b>
	IN [6]	15,04 x 9 x 72,0	G1			A 352 053 22 29 A 366 053 07 29	<b>81-1674</b>
	EX [6]	15,00 x 10 x 73,0	G1			A 352 053 16 30	<b>81-1658</b>
	EX [6]	15,00 x 10 x 78,0	G1			A 321 053 12 30	<b>81-1631</b>
	EX [6]	15,03 x 10 x 67,0	G1			A 352 053 20 30	<b>81-1670</b>
	EX [6]	15,04 x 10 x 67,0	G1			A 352 053 37 30 A 366 053 02 30	<b>81-1676</b>
	EX [6]	15,10 x 10 x 78,0	G1			A 321 053 13 30	<b>81-1632</b>
	EX [6]	15,20 x 10 x 73,0	G1			A 352 053 18 30	<b>81-1659</b>
	IN [1]	45,08 x 37 x 8,3	G1 45°			A 352 053 16 31 A 352 053 22 31 A 352 053 31 31	<b>92-16112</b>
	IN [1]	45,87 x 37 x 8,2	G1 45°			A 352 053 35 31 A 352 053 38 31 A 352 053 40 31	<b>92-16114</b>
	EX [2]	38,07 x 30 x 8,5	G1 45°			A 366 053 16 32	<b>92-16109</b>
	EX [1]	38,38 x 30 x 8,5	G1 45°			A 352 053 16 32 A 352 053 21 32	<b>92-16131</b>
		739 mm				A 352 050 44 01	<b>20 1003 35200</b> (1)
		(1) Zahnrad aufgeschumpft/gear shrinked on/pignon emmanché/rueda dentada zunchada/зубчатое колесо запрессовано нагорячую					
	[12]	M 28 x 60				A 352 054 05 01	<b>20 1003 35260</b>
	I [1]					A 352 050 10 33 A 366 050 04 33	<b>20 1003 36602</b> (2)
	(2) IN						
<b>151</b>	<b>97</b>						
<b>OM 352</b>	<b>900</b>						
90 274 8..., 93 882 6..	1974 → 1982	D	6	5675 cm <sup>3</sup> 2V		128,00 mm (1)	
(1) OM 352 ... II.Series 1966 -							
Fortsetzung nächste Seite / continued on next page / suite page suivante / continuación página próxima / Продолжение на следующей странице							

M

					Reference	Item No.
IN [2]	44,0 x 9 x 140,5	A/S - Cr -	- 45° - -	5 - III	A 352 050 00 26 A 352 050 01 26 A 352 053 01 01	<b>16136</b>
EX [2]	36,0 x 10 x 140,6	A/S - Cr -	- 45° - -	5 - III	A 321 053 09 05 A 366 050 00 27 A 366 050 01 27 A 366 050 05 27 A 366 050 06 27 A 376 050 00 27 A 376 050 01 27	<b>16106</b>
IN [6]	15,00 x 9 x 78,0	G1			A 312 053 02 30	<b>81-1609</b>
IN [6]	15,04 x 9 x 72,0	G1			A 352 053 22 29 A 366 053 07 29	<b>81-1674</b>
EX [6]	15,00 x 10 x 73,0	G1			A 352 053 16 30	<b>81-1658</b>
EX [6]	15,03 x 10 x 67,0	G1			A 352 053 20 30	<b>81-1670</b>
EX [6]	15,04 x 10 x 67,0	G1			A 352 053 37 30 A 366 053 02 30	<b>81-1676</b>
EX [6]	15,20 x 10 x 73,0	G1			A 352 053 18 30	<b>81-1659</b>
IN [1]	45,08 x 37 x 8,3	G1 45°			A 352 053 16 31 A 352 053 22 31 A 352 053 31 31	<b>92-16112</b>
IN [1]	45,87 x 37 x 8,2	G1 45°			A 352 053 35 31 A 352 053 38 31 A 352 053 40 31	<b>92-16114</b>
EX [2]	38,07 x 30 x 8,5	G1 45°			A 366 053 16 32	<b>92-16109</b>
EX [1]	38,38 x 30 x 8,5	G1 45°			A 352 053 16 32 A 352 053 21 32	<b>92-16131</b>
	739 mm 739 mm				A 352 050 44 01 A 352 050 49 01	<b>20 1003 35200</b> (2) <b>20 1003 35201</b> (3)
	(2) Zahnrad aufgeschumpft/gear shrunk on/pignon emmanché/rueda dentada zunchada/зубчатое колесо запрессовано на горячую					
	(3) Zahnrad angeschraubt/gear screwed on/pignon vissé/rueda dentada atornillada/зубчатое колесо привинчено					
[12]	M 28 x 60				A 352 054 05 01	<b>20 1003 35260</b>
I [1]					A 352 050 10 33 A 366 050 04 33	<b>20 1003 36602</b> (4)
	(4) IN					

**152**
**97**
**OM 344**
**919-063**

02.1975 →

D

6

 5675 cm<sup>3</sup> 2V

84 kW

(114 PS) 17:1

128,00 mm

90 274 8..., 93 882 6..

IN [6]	15,04 x 9 x 72,0	G1			A 352 053 22 29 A 366 053 07 29	<b>81-1674</b>
EX [6]	15,04 x 10 x 67,0	G1			A 352 053 37 30 A 366 053 02 30	<b>81-1676</b>
IN [1]	45,08 x 37 x 8,3	G1 45°			A 352 053 16 31 A 352 053 22 31 A 352 053 31 31	<b>92-16112</b>
IN [1]	45,87 x 37 x 8,2	G1 45°			A 352 053 35 31 A 352 053 38 31 A 352 053 40 31	<b>92-16114</b>
EX [2]	38,07 x 30 x 8,5	G1 45°			A 366 053 16 32	<b>92-16109</b>
EX [1]	38,38 x 30 x 8,5	G1 45°			A 352 053 16 32 A 352 053 21 32	<b>92-16131</b>

					Reference	Item No.	
<b>153</b>		<b>97</b>	<b>OM 353</b> <b>985, 989</b> 09.1975 → 12.1987 D (NA) 6 5675 cm <sup>3</sup> 2V 70-96 kW (95-130 PS) 17:1 128,00 mm 90 274 8.., 93 882 6..				
	IN [2]	44,0 x 9 x 140,5	A/S - Cr -	- 45° - -	5 - III	A 352 050 00 26 A 352 050 01 26 A 352 053 01 01	<b>16136</b>
	EX [2]	36,0 x 10 x 140,5	A/S - Cr -	- 45° - -	5 - III	A 366 050 02 27	<b>16122</b>
	EX [2]	36,0 x 10 x 140,5	S - Cr -	- 45° - VS -	5 - III	A 352 053 15 05	<b>1604</b>
	EX [2]	36,0 x 10 x 140,6	A/S - Cr -	- 45° - -	5 - III	A 321 053 09 05 A 366 050 00 27 A 366 050 01 27 A 366 050 05 27 A 366 050 06 27 A 376 050 00 27 A 376 050 01 27	<b>16106</b>
	IN [6]	15,00 x 9 x 78,0	G1			A 312 053 02 30	<b>81-1609</b>
	IN [6]	15,03 x 9 x 72,0	G1			A 352 053 12 29	<b>81-1666</b>
	IN [6]	15,04 x 9 x 72,0	G1			A 352 053 22 29 A 366 053 07 29	<b>81-1674</b>
	EX [6]	15,00 x 10 x 73,0	G1			A 352 053 16 30	<b>81-1658</b>
	EX [6]	15,00 x 10 x 78,0	G1			A 321 053 12 30	<b>81-1631</b>
	EX [6]	15,03 x 10 x 67,0	G1			A 352 053 20 30	<b>81-1670</b>
	EX [6]	15,04 x 10 x 67,0	G1			A 352 053 37 30 A 366 053 02 30	<b>81-1676</b>
	EX [6]	15,10 x 10 x 78,0	G1			A 321 053 13 30	<b>81-1632</b>
	EX [6]	15,20 x 10 x 73,0	G1			A 352 053 18 30	<b>81-1659</b>
	IN [1]	45,08 x 37 x 8,3	G1 45°			A 352 053 16 31 A 352 053 22 31 A 352 053 31 31	<b>92-16112</b>
	IN [1]	45,87 x 37 x 8,2	G1 45°			A 352 053 35 31 A 352 053 38 31 A 352 053 40 31	<b>92-16114</b>
	EX [2]	38,07 x 30 x 8,5	G1 45°			A 366 053 16 32	<b>92-16109</b>
	EX [1]	38,38 x 30 x 8,5	G1 45°			A 352 053 16 32 A 352 053 21 32	<b>92-16131</b>
		739 mm				A 352 050 49 01	<b>20 1003 35201</b> (1)
		(1) Zahnrad angeschraubt/gear screwed on/pignon vissé/rueda dentada atornillada/зубчатое колесо привинчено					
	[12]	M 28 x 60				A 352 054 05 01	<b>20 1003 35260</b>
	I [1]					A 352 050 10 33 A 366 050 04 33	<b>20 1003 36602</b> (2)
	(2) IN						
<b>154</b>		<b>97</b>	<b>OM 396</b> <b>900-022 (AFS)</b> 09.1975 → 05.1986 D 6 5675 cm <sup>3</sup> 2V 88 kW (120 PS) 17:1 128,00 mm 90 274 8.., 93 882 6..				
	EX [2]	38,07 x 30 x 8,5	G1 45°			A 366 053 16 32	<b>92-16109</b>
	EX [1]	38,38 x 30 x 8,5	G1 45°			A 352 053 16 32 A 352 053 21 32	<b>92-16131</b>

M

					Reference	Item No.
--	--	--	--	--	-----------	----------

**155** **97**

OM 353

954

11.1975 → 09.1985 D (A) 6 5675 cm<sup>3</sup> 2V 124 kW (168 PS) 16,5:1 128,00 mm

90 276 7..., 92 581 6..

	IN [2]	44,0 x 9 x 140,5	A/S - Cr -	- 45° - -	5 - III	A 352 050 00 26 A 352 050 01 26 A 352 053 01 01	<b>16136</b>
	EX [2]	36,0 x 10 x 140,5	A/S - Cr -	- 45° - -	5 - III	A 366 050 02 27	<b>16122</b>
	EX [2]	36,0 x 10 x 140,5	S - Cr -	- 45° - VS -	5 - III	A 352 053 15 05	<b>1604</b>
	EX [2]	36,0 x 10 x 140,6	A/S - Cr -	- 45° - -	5 - III	A 321 053 09 05 A 366 050 00 27 A 366 050 01 27 A 366 050 05 27 A 366 050 06 27 A 376 050 00 27 A 376 050 01 27	<b>16106</b>
	IN [6]	15,00 x 9 x 78,0	G1			A 312 053 02 30	<b>81-1609</b>
	IN [6]	15,03 x 9 x 72,0	G1			A 352 053 12 29	<b>81-1666</b>
	IN [6]	15,04 x 9 x 72,0	G1			A 352 053 22 29 A 366 053 07 29	<b>81-1674</b>
	EX [6]	15,03 x 10 x 67,0	G1			A 352 053 20 30	<b>81-1670</b>
	EX [6]	15,04 x 10 x 67,0	G1			A 352 053 37 30	<b>81-1676</b>
	EX [6]	15,10 x 10 x 78,0	G1			A 366 053 02 30	<b>81-1632</b>
	EX [6]	15,20 x 10 x 73,0	G1			A 321 053 13 30 A 352 053 18 30	<b>81-1659</b>
	IN [1]	45,08 x 37 x 8,3	G1 45°			A 352 053 16 31 A 352 053 22 31 A 352 053 31 31	<b>92-16112</b>
	IN [1]	45,87 x 37 x 8,2	G1 45°			A 352 053 35 31 A 352 053 38 31 A 352 053 40 31	<b>92-16114</b>
	EX [2]	38,07 x 30 x 8,5	G1 45°			A 366 053 16 32	<b>92-16109</b>
	EX [1]	38,38 x 30 x 8,5	G1 45°			A 352 053 16 32 A 352 053 21 32	<b>92-16131</b>
		739 mm				A 352 050 50 01	<b>20 1003 35202 (1)</b>
		(1) Zahnrad angeschraubt/gear screwed on/pignon vissé/rueda dentada atornillada/зубчатое колесо привинчено					
	[12]	M 28 x 60				A 352 054 05 01	<b>20 1003 35260</b>
	I [1]					A 352 050 10 33 A 366 050 04 33	<b>20 1003 36602 (2)</b>
	(2) IN						

**156** **97**

OM 353

974 - 975

11.1975 → D (A) 6 5675 cm<sup>3</sup> 2V 124-127 kW (168-172 PS) 128,00 mm

90 276 7..., 92 581 6..

Fortsetzung nächste Seite / continued on next page / suite page suivante / continuación página próxima / Продолжение на следующей странице

					<b>Reference</b>	<b>Item No.</b>
	IN [2] 44,0 x 9 x 140,5	A/S - Cr -	- 45° - -	5 - III	A 352 050 00 26 A 352 050 01 26 A 352 053 01 01	<b>16136</b>
	EX [2] 36,0 x 10 x 140,5	A/S - Cr -	- 45° - -	5 - III	A 366 050 02 27	<b>16122</b>
	EX [2] 36,0 x 10 x 140,5	S - Cr -	- 45° - VS -	5 - III	A 352 053 15 05	<b>1604</b>
	EX [2] 36,0 x 10 x 140,6	A/S - Cr -	- 45° - -	5 - III	A 321 053 09 05 A 366 050 00 27 A 366 050 01 27 A 366 050 05 27 A 366 050 06 27 A 376 050 00 27 A 376 050 01 27	<b>16106</b>
	IN [6] 15,00 x 9 x 78,0	G1			A 312 053 02 30	<b>81-1609</b>
	IN [6] 15,03 x 9 x 72,0	G1			A 352 053 12 29	<b>81-1666</b>
	IN [6] 15,04 x 9 x 72,0	G1			A 352 053 22 29 A 366 053 07 29	<b>81-1674</b>
	EX [6] 15,00 x 10 x 73,0	G1			A 352 053 16 30	<b>81-1658</b>
	EX [6] 15,00 x 10 x 78,0	G1			A 321 053 12 30	<b>81-1631</b>
	EX [6] 15,03 x 10 x 67,0	G1			A 352 053 20 30	<b>81-1670</b>
	EX [6] 15,04 x 10 x 67,0	G1			A 352 053 37 30 A 366 053 02 30	<b>81-1676</b>
	EX [6] 15,10 x 10 x 78,0	G1			A 321 053 13 30	<b>81-1632</b>
	EX [6] 15,20 x 10 x 73,0	G1			A 352 053 18 30	<b>81-1659</b>
	IN [1] 45,08 x 37 x 8,3	G1 45°			A 352 053 16 31 A 352 053 22 31 A 352 053 31 31	<b>92-16112</b>
	IN [1] 45,87 x 37 x 8,2	G1 45°			A 352 053 35 31 A 352 053 38 31 A 352 053 40 31	<b>92-16114</b>
	EX [2] 38,07 x 30 x 8,5	G1 45°			A 366 053 16 32	<b>92-16109</b>
	EX [1] 38,38 x 30 x 8,5	G1 45°			A 352 053 16 32 A 352 053 21 32	<b>92-16131</b>
	739 mm				A 366 050 04 01 A 366 050 06 01 A 366 051 11 01	<b>20 1003 36601</b>
	[12] M 28 x 60				A 352 054 05 01	<b>20 1003 35260</b>
	I [1]				A 352 050 10 33 A 366 050 04 33	<b>20 1003 36602 (1)</b>
	(1) IN					

**157**
**97**
**OM 344**
**964 (USA)**

02.1976 → 12.1984

D

6

 5675 cm<sup>3</sup> 2V

94 kW

(126 PS) 17:1

128,00 mm

	IN [2] 42,0 x 9 x 140,5	A/S - Cr -	- 30° - -	5 - III	A 366 050 03 26	<b>16130</b>
	IN [2] 43,0 x 9 x 140,5	A/S - Cr -	- 30° - -	5 - III	A 366 050 02 26	<b>16109</b>
	IN [2] 44,0 x 9 x 140,5	A/S - Cr -	- 45° - -	5 - III	A 352 050 00 26 A 352 050 01 26 A 352 053 01 01	<b>16136</b>
	EX [2] 36,0 x 10 x 140,5	A/S - Cr -	- 45° - -	5 - III	A 366 050 02 27	<b>16122</b>
	EX [2] 36,0 x 10 x 140,5	S - Cr -	- 45° - VS -	5 - III	A 352 053 15 05	<b>1604</b>
	EX [2] 36,0 x 10 x 140,6	A/S - Cr -	- 45° - -	5 - III	A 321 053 09 05 A 366 050 00 27 A 366 050 01 27 A 366 050 05 27 A 366 050 06 27 A 376 050 00 27 A 376 050 01 27	<b>16106</b>

Fortsetzung nächste Seite / continued on next page / suite page suivante / continuación página próxima / Продолжение на следующей странице



					Reference	Item No.
IN [6]	15,04 x 9 x 72,0	G1			A 352 053 22 29 A 366 053 07 29	<b>81-1674</b>
EX [6]	15,04 x 10 x 67,0	G1			A 352 053 37 30 A 366 053 02 30	<b>81-1676</b>
IN [1]	45,08 x 37 x 8,3	G1 45°			A 352 053 16 31 A 352 053 22 31 A 352 053 31 31	<b>92-16112</b>
IN [1]	45,87 x 37 x 8,2	G1 45°			A 352 053 35 31 A 352 053 38 31 A 352 053 40 31	<b>92-16114</b>
EX [2]	38,07 x 30 x 8,5	G1 45°			A 366 053 16 32	<b>92-16109</b>
EX [1]	38,38 x 30 x 8,5	G1 45°			A 352 053 16 32 A 352 053 21 32	<b>92-16131</b>
	739 mm				A 352 050 49 01	<b>20 1003 35201</b> (1)
	(1) Zahnrad angeschraubt/gear screwed on/pignon vissé/rueda dentada atornillada/зубчатое колесо привинчено					
[12]	M 28 x 60				A 352 054 05 01	<b>20 1003 35260</b>

**158**
**97**
**OM 353**
**958**

 02.1976 → 05.1988 D (A) 6 5675 cm<sup>3</sup> 2V 110 kW (150 PS) 16,5:1 128,00 mm

90 276 7.., 92 581 6..

IN [2]	44,0 x 9 x 140,5	A/S - Cr -	- 45° - -	5 - III	A 352 050 00 26 A 352 050 01 26 A 352 053 01 01	<b>16136</b>
EX [2]	36,0 x 10 x 140,5	A/S - Cr -	- 45° - -	5 - III	A 366 050 02 27	<b>16122</b>
EX [2]	36,0 x 10 x 140,5	S - Cr -	- 45° - VS -	5 - III	A 352 053 15 05	<b>1604</b>
EX [2]	36,0 x 10 x 140,6	A/S - Cr -	- 45° - -	5 - III	A 321 053 09 05 A 366 050 00 27 A 366 050 01 27 A 366 050 05 27 A 366 050 06 27 A 376 050 00 27 A 376 050 01 27	<b>16106</b>
IN [6]	15,00 x 9 x 78,0	G1			A 312 053 02 30	<b>81-1609</b>
IN [6]	15,03 x 9 x 72,0	G1			A 352 053 12 29	<b>81-1666</b>
IN [6]	15,04 x 9 x 72,0	G1			A 352 053 22 29 A 366 053 07 29	<b>81-1674</b>
EX [6]	15,00 x 10 x 73,0	G1			A 352 053 16 30	<b>81-1658</b>
EX [6]	15,03 x 10 x 67,0	G1			A 352 053 20 30	<b>81-1670</b>
EX [6]	15,04 x 10 x 67,0	G1			A 352 053 37 30 A 366 053 02 30	<b>81-1676</b>
EX [6]	15,20 x 10 x 73,0	G1			A 352 053 18 30	<b>81-1659</b>
IN [1]	45,08 x 37 x 8,3	G1 45°			A 352 053 16 31 A 352 053 22 31 A 352 053 31 31	<b>92-16112</b>
IN [1]	45,87 x 37 x 8,2	G1 45°			A 352 053 35 31 A 352 053 38 31 A 352 053 40 31	<b>92-16114</b>
EX [2]	38,07 x 30 x 8,5	G1 45°			A 366 053 16 32	<b>92-16109</b>
EX [1]	38,38 x 30 x 8,5	G1 45°			A 352 053 16 32 A 352 053 21 32	<b>92-16131</b>
	739 mm				A 352 050 50 01	<b>20 1003 35202</b> (1)
	(1) Zahnrad angeschraubt/gear screwed on/pignon vissé/rueda dentada atornillada/зубчатое колесо привинчено					

Fortsetzung nächste Seite / continued on next page / suite page suivante / continuación página próxima / Продолжение на следующей странице

					Reference	Item No.
[12]	M 28 x 60				A 352 054 05 01	20 1003 35260
I [1]					A 352 050 10 33 A 366 050 04 33	20 1003 36602 (2)
	(2) IN					

**159**
**97**
**OM 344**
**943, 945**

06.1976 →

D (NA) 6

 5675 cm<sup>3</sup> 2V

96 kW

(131 PS) 17:1

128,00 mm

90 274 8.., 93 882 6..

IN [2]	44,0 x 9 x 140,5	A/S - Cr -	- 45° - -	5 - III	A 352 050 00 26 A 352 050 01 26 A 352 053 01 01	<b>16136</b>
EX [2]	36,0 x 10 x 140,5	A/S - Cr -	- 45° - -	5 - III	A 366 050 02 27	<b>16122</b>
EX [2]	36,0 x 10 x 140,5	S - Cr -	- 45° - VS -	5 - III	A 352 053 15 05	<b>1604</b>
EX [2]	36,0 x 10 x 140,6	A/S - Cr -	- 45° - -	5 - III	A 321 053 09 05 A 366 050 00 27 A 366 050 01 27 A 366 050 05 27 A 366 050 06 27 A 376 050 00 27 A 376 050 01 27	<b>16106</b>
IN [6]	15,03 x 9 x 72,0	G1			A 352 053 12 29	<b>81-1666</b>
IN [6]	15,04 x 9 x 72,0	G1			A 352 053 22 29 A 366 053 07 29	<b>81-1674</b>
EX [6]	15,00 x 10 x 73,0	G1			A 352 053 16 30	<b>81-1658</b>
EX [6]	15,04 x 10 x 67,0	G1			A 352 053 37 30 A 366 053 02 30	<b>81-1676</b>
EX [6]	15,20 x 10 x 73,0	G1			A 352 053 18 30	<b>81-1659</b>
IN [1]	45,08 x 37 x 8,3	G1 45°			A 352 053 16 31 A 352 053 22 31 A 352 053 31 31	<b>92-16112</b>
IN [1]	45,87 x 37 x 8,2	G1 45°			A 352 053 35 31 A 352 053 38 31 A 352 053 40 31	<b>92-16114</b>
EX [2]	38,07 x 30 x 8,5	G1 45°			A 366 053 16 32	<b>92-16109</b>
EX [1]	38,38 x 30 x 8,5	G1 45°			A 352 053 16 32 A 352 053 21 32	<b>92-16131</b>
[12]	M 28 x 60				A 352 054 05 01	20 1003 35260

**160**
**97**
**OM 353**
**957**

10.1976 → 03.1987

D (A) 6

 5675 cm<sup>3</sup> 2V

92 kW

(125 PS) 17:1

128,00 mm

90 274 8.., 93 882 6..

IN [2]	44,0 x 9 x 140,5	A/S - Cr -	- 45° - -	5 - III	A 352 050 00 26 A 352 050 01 26 A 352 053 01 01	<b>16136</b>
EX [2]	36,0 x 10 x 140,5	A/S - Cr -	- 45° - -	5 - III	A 366 050 02 27	<b>16122</b>
EX [2]	36,0 x 10 x 140,5	S - Cr -	- 45° - VS -	5 - III	A 352 053 15 05	<b>1604</b>
EX [2]	36,0 x 10 x 140,6	A/S - Cr -	- 45° - -	5 - III	A 321 053 09 05 A 366 050 00 27 A 366 050 01 27 A 366 050 05 27 A 366 050 06 27 A 376 050 00 27 A 376 050 01 27	<b>16106</b>

Fortsetzung nächste Seite / continued on next page / suite page suivante / continuación página próxima / Продолжение на следующей странице

					Reference	Item No.
	IN [6]	15,00 x 9 x 78,0	G1		A 312 053 02 30	<b>81-1609</b>
	IN [6]	15,03 x 9 x 72,0	G1		A 352 053 12 29	<b>81-1666</b>
	IN [6]	15,04 x 9 x 72,0	G1		A 352 053 22 29	<b>81-1674</b>
					A 366 053 07 29	
	EX [6]	15,00 x 10 x 73,0	G1		A 352 053 16 30	<b>81-1658</b>
	EX [6]	15,03 x 10 x 67,0	G1		A 352 053 20 30	<b>81-1670</b>
				A 352 053 37 30	<b>81-1676</b>	
	EX [6]	15,20 x 10 x 73,0	G1		A 366 053 02 30	
					A 352 053 18 30	<b>81-1659</b>
	IN [1]	45,08 x 37 x 8,3	G1 45°		A 352 053 16 31	<b>92-16112</b>
					A 352 053 22 31	
					A 352 053 31 31	
	IN [1]	45,87 x 37 x 8,2	G1 45°		A 352 053 35 31	<b>92-16114</b>
				A 352 053 38 31		
				A 352 053 40 31		
	EX [2]	38,07 x 30 x 8,5	G1 45°		A 366 053 16 32	<b>92-16109</b>
	EX [1]	38,38 x 30 x 8,5	G1 45°		A 352 053 16 32	<b>92-16131</b>
					A 352 053 21 32	
		739 mm			A 352 050 44 01	<b>20 1003 35200</b> (1) <b>20 1003 35201</b> (2) <b>20 1003 36601</b>
		739 mm			A 352 050 49 01	
		739 mm			A 366 050 04 01	
					A 366 050 06 01	
					A 366 051 11 01	
	(1)	Zahnrad aufgeschumpft/gear shrunked on/pignon emmanché/rueda dentada zunchada/зубчатое колесо запрессовано на горячую				
	(2)	Zahnrad angeschraubt/gear screwed on/pignon vissé/rueda dentada atornillada/зубчатое колесо привинчено				
	[12]	M 28 x 60			A 352 054 05 01	<b>20 1003 35260</b>
	I [1]				A 352 050 10 33	<b>20 1003 36602</b> (3)
					A 366 050 04 33	
	(3)	IN				

**161**
**97**
**OM 353**
**907**

01.1977 →

D

(NA)

6

 5675 cm<sup>3</sup> 2V

92 kW

(125 PS) 17:1

128,00 mm

90 274 8.., 93 882 6..

	IN [2]	44,0 x 9 x 140,5	A/S - Cr -	- 45° -	-	5 - III	A 352 050 00 26	<b>16136</b>
							A 352 050 01 26	
							A 352 053 01 01	
	EX [2]	36,0 x 10 x 140,5	A/S - Cr -	- 45° -	-	5 - III	A 366 050 02 27	
	EX [2]	36,0 x 10 x 140,5	S - Cr -	- 45° -	VS -	5 - III	A 352 053 15 05	
	EX [2]	36,0 x 10 x 140,6	A/S - Cr -	- 45° -	-	5 - III	A 321 053 09 05	<b>1604</b>
							A 366 050 00 27	<b>16106</b>
							A 366 050 01 27	
							A 366 050 05 27	
							A 366 050 06 27	
							A 376 050 00 27	
							A 376 050 01 27	

Fortsetzung nächste Seite / continued on next page / suite page suivante / continuación página próxima / Продолжение на следующей странице

					Reference	Item No.		
	IN [6]	15,00 x 9 x 78,0	G1		A 312 053 02 30	<b>81-1609</b>		
	IN [6]	15,03 x 9 x 72,0	G1		A 352 053 12 29	<b>81-1666</b>		
	IN [6]	15,04 x 9 x 72,0	G1		A 352 053 22 29	<b>81-1674</b>		
					A 366 053 07 29			
	EX [6]	15,00 x 10 x 73,0	G1		A 352 053 16 30	<b>81-1658</b>		
	EX [6]	15,00 x 10 x 78,0	G1		A 321 053 12 30	<b>81-1631</b>		
	EX [6]	15,03 x 10 x 67,0	G1		A 352 053 20 30	<b>81-1670</b>		
	EX [6]	15,04 x 10 x 67,0	G1		A 352 053 37 30	<b>81-1676</b>		
					A 366 053 02 30			
	EX [6]	15,10 x 10 x 78,0	G1		A 321 053 13 30	<b>81-1632</b>		
	EX [6]	15,20 x 10 x 73,0	G1		A 352 053 18 30	<b>81-1659</b>		
	IN [1]	45,08 x 37 x 8,3	G1 45°		A 352 053 16 31	<b>92-16112</b>		
					A 352 053 22 31			
	IN [1]	45,87 x 37 x 8,2	G1 45°		A 352 053 31 31	<b>92-16114</b>		
					A 352 053 35 31			
					A 352 053 38 31			
	EX [2]	38,07 x 30 x 8,5	G1 45°		A 352 053 40 31	<b>92-16109</b>		
	EX [1]	38,38 x 30 x 8,5	G1 45°		A 366 053 16 32	<b>92-16131</b>		
					A 352 053 16 32			
					A 352 053 21 32			
		739 mm			A 352 050 44 01	<b>20 1003 35200</b> (1)		
		739 mm			A 352 050 49 01	<b>20 1003 35201</b> (2)		
	(1)	Zahnrad aufgeschumpft/gear shrunk on/pignon emmanché/rueda dentada zunchada/зубчатое колесо запрессовано нагорячую						
	(2)	Zahnrad angeschraubt/gear screwed on/pignon vissé/rueda dentada atornillada/зубчатое колесо привинчено						
	[12]	M 28 x 60			A 352 054 05 01	<b>20 1003 35260</b>		
	I [1]				A 352 050 10 33	<b>20 1003 36602</b> (3)		
					A 366 050 04 33			
	(3)	IN						
<b>162</b>		<b>97</b>						
<b>OM 353</b>	<b>959</b>							
93 750 6..	05.1978 → 09.1988	D (A)	6	5675 cm <sup>3</sup>	2V	124 kW (168 PS) 16,5:1 128,00 mm		
	IN [2]	44,0 x 9 x 140,5	A/S - Cr -	- 45° -	-	5 - III	A 352 050 00 26	<b>16136</b>
							A 352 050 01 26	
							A 352 053 01 01	
	EX [2]	36,0 x 10 x 140,5	A/S - Cr -	- 45° -	-	5 - III	A 366 050 02 27	
	EX [2]	36,0 x 10 x 140,5	S - Cr -	- 45° -	VS -	5 - III	A 352 053 15 05	
	EX [2]	36,0 x 10 x 140,6	A/S - Cr -	- 45° -	-	5 - III	A 321 053 09 05	
							A 366 050 00 27	
							A 366 050 01 27	
							A 366 050 05 27	
						A 366 050 06 27		
						A 376 050 00 27		
						A 376 050 01 27		
	IN [6]	15,00 x 9 x 78,0	G1				A 312 053 02 30	<b>81-1609</b>
	IN [6]	15,03 x 9 x 72,0	G1				A 352 053 12 29	
	IN [6]	15,04 x 9 x 72,0	G1				A 352 053 22 29	
							A 366 053 07 29	
	EX [6]	15,00 x 10 x 73,0	G1				A 352 053 16 30	
	EX [6]	15,03 x 10 x 67,0	G1				A 321 053 12 30	
	EX [6]	15,04 x 10 x 67,0	G1				A 352 053 20 30	
							A 352 053 37 30	
							A 366 053 02 30	
	EX [6]	15,20 x 10 x 73,0	G1				A 352 053 18 30	
Fortsetzung nächste Seite / continued on next page / suite page suivante / continuación página próxima / Продолжение на следующей странице								

					Reference	Item No.
IN [1]	45,08 x 37 x 8,3	G1 45°			A 352 053 16 31 A 352 053 22 31 A 352 053 31 31	<b>92-16112</b>
IN [1]	45,87 x 37 x 8,2	G1 45°			A 352 053 35 31 A 352 053 38 31 A 352 053 40 31	<b>92-16114</b>
EX [2]	38,07 x 30 x 8,5	G1 45°			A 366 053 16 32	<b>92-16109</b>
EX [1]	38,38 x 30 x 8,5	G1 45°			A 352 053 16 32 A 352 053 21 32	<b>92-16131</b>
	739 mm 739 mm				A 352 050 50 01 A 366 050 04 01 A 366 050 06 01 A 366 051 11 01	<b>20 1003 35202</b> (1) <b>20 1003 36601</b>
	(1) Zahnrad angeschraubt/gear screwed on/pignon vissé/rueda dentada atornillada/зубчатое колесо привинчено					
[12]	M 28 x 60				A 352 054 05 01	<b>20 1003 35260</b>
I [1]					A 352 050 10 33 A 366 050 04 33	<b>20 1003 36602</b> (2)
	(2) IN					

**163**
**97**
**OM 344**
**920**

D 6 5675 cm<sup>3</sup> 2V 103 kW (140 PS) 17:1 128,00 mm

IN [2]	43,0 x 9 x 140,5	A/S - Cr -	- 30° - -	5 - III	A 366 050 02 26	<b>16109</b>
IN [2]	44,0 x 9 x 140,5	A/S - Cr -	- 45° - -	5 - III	A 352 050 00 26 A 352 050 01 26 A 352 053 01 01	<b>16136</b>
EX [2]	36,0 x 10 x 140,5	A/S - Cr -	- 45° - -	5 - III	A 366 050 02 27	<b>16122</b>
EX [2]	36,0 x 10 x 140,5	S - Cr -	- 45° - VS -	5 - III	A 352 053 15 05	<b>1604</b>
EX [2]	36,0 x 10 x 140,6	A/S - Cr -	- 45° - -	5 - III	A 321 053 09 05 A 366 050 00 27 A 366 050 01 27 A 366 050 05 27 A 366 050 06 27 A 376 050 00 27 A 376 050 01 27	<b>16106</b>
IN [6]	15,00 x 9 x 78,0	G1			A 312 053 02 30	<b>81-1609</b>
IN [6]	15,03 x 9 x 72,0	G1			A 352 053 12 29	<b>81-1666</b>
IN [6]	15,04 x 9 x 72,0	G1			A 352 053 22 29 A 366 053 07 29	<b>81-1674</b>
EX [6]	15,03 x 10 x 67,0	G1			A 352 053 20 30	<b>81-1670</b>
EX [6]	15,04 x 10 x 67,0	G1			A 352 053 37 30 A 366 053 02 30	<b>81-1676</b>
	739 mm				A 352 050 49 01	<b>20 1003 35201</b> (1)
	(1) Zahnrad angeschraubt/gear screwed on/pignon vissé/rueda dentada atornillada/зубчатое колесо привинчено					
[12]	M 28 x 60				A 352 054 05 01	<b>20 1003 35260</b>

**164**
**97**
**OM 353**
**920 - 921, 939**

01.1980 →

D (A) 6 5675 cm<sup>3</sup> 2V 110-124 kW (150-169 PS) 16:1 128,00 mm

90 276 7.., 92 581 6.., 93 750 6..

Fortsetzung nächste Seite / continued on next page / suite page suivante / continuación página próxima / Продолжение на следующей странице



					Reference	Item No.
	IN [2] 44,0 x 9 x 140,5	A/S - Cr -	- 45° - -	5 - III	A 352 050 00 26 A 352 050 01 26 A 352 053 01 01	<b>16136</b>
	EX [2] 36,0 x 10 x 140,5	A/S - Cr -	- 45° - -	5 - III	A 366 050 02 27	<b>16122</b>
	EX [2] 36,0 x 10 x 140,5	S - Cr -	- 45° - VS -	5 - III	A 352 053 15 05	<b>1604</b>
	EX [2] 36,0 x 10 x 140,6	A/S - Cr -	- 45° - -	5 - III	A 321 053 09 05 A 366 050 00 27 A 366 050 01 27 A 366 050 05 27 A 366 050 06 27 A 376 050 00 27 A 376 050 01 27	<b>16106</b>
	IN [6] 15,00 x 9 x 78,0	G1			A 312 053 02 30	<b>81-1609</b>
	IN [6] 15,03 x 9 x 72,0	G1			A 352 053 12 29	<b>81-1666</b>
	IN [6] 15,04 x 9 x 72,0	G1			A 352 053 22 29 A 366 053 07 29	<b>81-1674</b>
	EX [6] 15,03 x 10 x 67,0	G1			A 352 053 20 30	<b>81-1670</b>
	EX [6] 15,04 x 10 x 67,0	G1			A 352 053 37 30 A 366 053 02 30	<b>81-1676</b>
	IN [1] 45,08 x 37 x 8,3	G1 45°			A 352 053 16 31 A 352 053 22 31 A 352 053 31 31	<b>92-16112</b>
	IN [1] 45,87 x 37 x 8,2	G1 45°			A 352 053 35 31 A 352 053 38 31 A 352 053 40 31	<b>92-16114</b>
	EX [2] 38,07 x 30 x 8,5	G1 45°			A 366 053 16 32	<b>92-16109</b>
	EX [1] 38,38 x 30 x 8,5	G1 45°			A 352 053 16 32 A 352 053 21 32	<b>92-16131</b>
	739 mm				A 366 050 04 01 A 366 050 06 01 A 366 051 11 01	<b>20 1003 36601</b>
	[12] M 28 x 60				A 352 054 05 01	<b>20 1003 35260</b>
	I [1]  (1) IN				A 352 050 10 33 A 366 050 04 33	<b>20 1003 36602 (1)</b>

**165**
**97**
**OM 396**
**900-405 (AFS), 900-407, 900-409, 900-410, 900-415**

01.1980 →

D

6

 5675 cm<sup>3</sup> 2V

110-124 kW

(150-168 PS) 17:1

128,00 mm

93 750 6..

	IN [2] 44,0 x 9 x 140,5	A/S - Cr -	- 45° - -	5 - III	A 352 050 00 26 A 352 050 01 26 A 352 053 01 01	<b>16136</b>
	EX [2] 36,0 x 10 x 140,5	A/S - Cr -	- 45° - -	5 - III	A 366 050 02 27	<b>16122</b>
	EX [2] 36,0 x 10 x 140,5	S - Cr -	- 45° - VS -	5 - III	A 352 053 15 05	<b>1604</b>
	EX [2] 36,0 x 10 x 140,6	A/S - Cr -	- 45° - -	5 - III	A 321 053 09 05 A 366 050 00 27 A 366 050 01 27 A 366 050 05 27 A 366 050 06 27 A 376 050 00 27 A 376 050 01 27	<b>16106</b>
	IN [6] 15,03 x 9 x 72,0	G1			A 352 053 12 29	<b>81-1666</b>
	IN [6] 15,04 x 9 x 72,0	G1			A 352 053 22 29 A 366 053 07 29	<b>81-1674</b>
	EX [6] 15,04 x 10 x 67,0	G1			A 352 053 37 30 A 366 053 02 30	<b>81-1676</b>

Fortsetzung nächste Seite / continued on next page / suite page suivante / continuación página próxima / Продолжение на следующей странице

					Reference	Item No.
	IN [1] IN [1]	43,87 x 34,5 x 7,4 45,08 x 37 x 8,3	G1 G1 45°		A 366 053 35 31 A 352 053 16 31 A 352 053 22 31 A 352 053 31 31	<b>92-16155</b> <b>92-16112</b>
	IN [1]	45,87 x 37 x 8,2	G1 45°		A 352 053 35 31 A 352 053 38 31 A 352 053 40 31	<b>92-16114</b>
	EX [2] EX [1]	38,07 x 30 x 8,5 38,38 x 30 x 8,5	G1 45° G1 45°		A 366 053 16 32 A 352 053 16 32 A 352 053 21 32	<b>92-16109</b> <b>92-16131</b>

## 166

OM 353

976

07.1980 → 03.1987 D (A) 6 5675 cm<sup>3</sup> 2V 110 kW (150 PS) 16,5:1 128,00 mm

90 276 7... 92 581 6..

	IN [2]  EX [2] EX [2] EX [2]	44,0 x 9 x 140,5  36,0 x 10 x 140,5 36,0 x 10 x 140,5 36,0 x 10 x 140,6	A/S - Cr -  A/S - Cr - S - Cr - A/S - Cr -	- 45° - -  - 45° - - - 45° - VS - - 45° - -	5 - III  5 - III 5 - III 5 - III	A 352 050 00 26 A 352 050 01 26 A 352 053 01 01 A 366 050 02 27 A 352 053 15 05 A 321 053 09 05 A 366 050 00 27 A 366 050 01 27 A 366 050 05 27 A 366 050 06 27 A 376 050 00 27 A 376 050 01 27	<b>16136</b>  <b>16122</b> <b>1604</b> <b>16106</b>
	IN [6] IN [6]  EX [6]	15,00 x 9 x 78,0 15,04 x 9 x 72,0  15,04 x 10 x 67,0	G1 G1  G1			A 312 053 02 30 A 352 053 22 29 A 366 053 07 29 A 352 053 37 30 A 366 053 02 30	<b>81-1609</b> <b>81-1674</b>  <b>81-1676</b>
	IN [1]  IN [1]  EX [2] EX [1]	45,08 x 37 x 8,3  45,87 x 37 x 8,2  38,07 x 30 x 8,5 38,38 x 30 x 8,5	G1 45°  G1 45°  G1 45° G1 45°			A 352 053 16 31 A 352 053 22 31 A 352 053 31 31 A 352 053 35 31 A 352 053 38 31 A 352 053 40 31 A 366 053 16 32 A 352 053 16 32 A 352 053 21 32	<b>92-16112</b>  <b>92-16114</b>  <b>92-16109</b> <b>92-16131</b>
		739 mm				A 366 050 04 01 A 366 050 06 01 A 366 051 11 01	<b>20 1003 36601</b>
	[12]	M 28 x 60				A 352 054 05 01	<b>20 1003 35260</b>
	I [1]  (1) IN					A 352 050 10 33 A 366 050 04 33	<b>20 1003 36602</b> (1)

## 167

OM 314

970

09.1981 → 12.1982 D (A) 4 3782 cm<sup>3</sup> 2V 63 kW (85 PS) 16:1 128,00 mm

93 750 6..

Fortsetzung nächste Seite / continued on next page / suite page suivante / continuación página próxima / Продолжение на следующей странице

					Reference	Item No.
	IN [2] 44,0 x 9 x 140,5	A/S - Cr -	- 45° - -	5 - III	A 352 050 00 26 A 352 050 01 26 A 352 053 01 01	<b>16136</b>
	EX [2] 36,0 x 10 x 140,5	A/S - Cr -	- 45° - -	5 - III	A 366 050 02 27	<b>16122</b>
	EX [2] 36,0 x 10 x 140,5	S - Cr -	- 45° - VS -	5 - III	A 352 053 15 05	<b>1604</b>
	EX [2] 36,0 x 10 x 140,6	A/S - Cr -	- 45° - -	5 - III	A 321 053 09 05 A 366 050 00 27 A 366 050 01 27 A 366 050 05 27 A 366 050 06 27 A 376 050 00 27 A 376 050 01 27	<b>16106</b>
	IN [6] 15,00 x 9 x 78,0	G1			A 312 053 02 30	<b>81-1609</b>
	IN [6] 15,04 x 9 x 72,0	G1			A 352 053 22 29 A 366 053 07 29	<b>81-1674</b>
	EX [6] 15,00 x 10 x 73,0	G1			A 352 053 16 30	<b>81-1658</b>
	EX [6] 15,03 x 10 x 67,0	G1			A 352 053 20 30	<b>81-1670</b>
	EX [6] 15,04 x 10 x 67,0	G1			A 352 053 37 30 A 366 053 02 30	<b>81-1676</b>
	EX [6] 15,20 x 10 x 73,0	G1			A 352 053 18 30	<b>81-1659</b>
	IN [1] 45,08 x 37 x 8,3	G1 45°			A 352 053 16 31 A 352 053 22 31 A 352 053 31 31	<b>92-16112</b>
	IN [1] 45,87 x 37 x 8,2	G1 45°			A 352 053 35 31 A 352 053 38 31 A 352 053 40 31	<b>92-16114</b>
	EX [2] 38,07 x 30 x 8,5	G1 45°			A 366 053 16 32	<b>92-16109</b>
	EX [1] 38,38 x 30 x 8,5	G1 45°			A 352 053 16 32 A 352 053 21 32	<b>92-16131</b>
					A 364 050 04 01 A 364 050 06 01	<b>20 1003 36401</b>
	[12] M 28 x 60				A 352 054 05 01	<b>20 1003 35260</b>
	I [1]  (1) IN				A 352 050 10 33 A 366 050 04 33	<b>20 1003 36602 (1)</b>

**168**

**97**
**OM 353**
**995**

 02.1982 → 05.1988 D (A) 6 5675 cm<sup>3</sup> 2V 92 kW (125 PS) 16,5:1 128,00 mm

90 274 8.., 93 882 6..

	IN [2] 44,0 x 9 x 140,5	A/S - Cr -	- 45° - -	5 - III	A 352 050 00 26 A 352 050 01 26 A 352 053 01 01	<b>16136</b>
	EX [2] 36,0 x 10 x 140,5	A/S - Cr -	- 45° - -	5 - III	A 366 050 02 27	<b>16122</b>
	EX [2] 36,0 x 10 x 140,5	S - Cr -	- 45° - VS -	5 - III	A 352 053 15 05	<b>1604</b>
	EX [2] 36,0 x 10 x 140,6	A/S - Cr -	- 45° - -	5 - III	A 321 053 09 05 A 366 050 00 27 A 366 050 01 27 A 366 050 05 27 A 366 050 06 27 A 376 050 00 27 A 376 050 01 27	<b>16106</b>

Fortsetzung nächste Seite / continued on next page / suite page suivante / continuación página próxima / Продолжение на следующей странице

					Reference	Item No.
	IN [6]	15,00 x 9 x 78,0	G1		A 312 053 02 30	<b>81-1609</b>
	IN [6]	15,03 x 9 x 72,0	G1		A 352 053 12 29	<b>81-1666</b>
	IN [6]	15,04 x 9 x 72,0	G1		A 352 053 22 29	<b>81-1674</b>
					A 366 053 07 29	
	EX [6]	15,00 x 10 x 73,0	G1		A 352 053 16 30	<b>81-1658</b>
	EX [6]	15,03 x 10 x 67,0	G1		A 352 053 20 30	<b>81-1670</b>
	EX [6]	15,04 x 10 x 67,0	G1		A 352 053 37 30	<b>81-1676</b>
	EX [6]	15,10 x 10 x 78,0	G1		A 366 053 02 30	
	EX [6]	15,20 x 10 x 73,0	G1		A 321 053 13 30	<b>81-1632</b>
					A 352 053 18 30	<b>81-1659</b>
	IN [1]	45,08 x 37 x 8,3	G1 45°		A 352 053 16 31	<b>92-16112</b>
					A 352 053 22 31	
	IN [1]	45,87 x 37 x 8,2	G1 45°		A 352 053 31 31	<b>92-16114</b>
					A 352 053 35 31	
	EX [2]	38,07 x 30 x 8,5	G1 45°		A 352 053 38 31	<b>92-16109</b>
	EX [1]	38,38 x 30 x 8,5	G1 45°		A 352 053 40 31	
					A 366 053 16 32	<b>92-16131</b>
					A 352 053 16 32	
					A 352 053 21 32	
		739 mm			A 352 050 49 01	<b>20 1003 35201</b> (1)
		(1) Zahnrad angeschraubt/gear screwed on/pignon vissé/rueda dentada atornillada/зубчатое колесо привинчено				
	[12]	M 28 x 60			A 352 054 05 01	<b>20 1003 35260</b>
	I [1]				A 352 050 10 33	<b>20 1003 36602</b> (2)
		(2) IN			A 366 050 04 33	

**169**
**97**
**OM 344**
**949**

01.1983→

D (A)

6

 5675 cm<sup>3</sup> 2V

96 kW

(131 PS) 16:1

128,00 mm

90 274 8.., 93 882 6..

	IN [2]	42,0 x 9 x 140,5	A/S - Cr -	- 30° - -	5 - III	A 366 050 03 26	<b>16130</b>
	IN [2]	43,0 x 9 x 140,5	A/S - Cr -	- 30° - -	5 - III	A 366 050 02 26	<b>16109</b>
	IN [2]	44,0 x 9 x 140,5	A/S - Cr -	- 45° - -	5 - III	A 352 050 00 26	<b>16136</b>
						A 352 050 01 26	
						A 352 053 01 01	
	EX [2]	36,0 x 10 x 140,5	A/S - Cr -	- 45° - -	5 - III	A 366 050 02 27	<b>16122</b>
	EX [2]	36,0 x 10 x 140,5	S - Cr -	- 45° - VS -	5 - III	A 352 053 15 05	<b>1604</b>
	EX [2]	36,0 x 10 x 140,6	A/S - Cr -	- 45° - -	5 - III	A 321 053 09 05	<b>16106</b>
						A 366 050 00 27	
						A 366 050 01 27	
						A 366 050 05 27	
						A 366 050 06 27	
						A 376 050 00 27	
						A 376 050 01 27	
	IN [6]	15,00 x 9 x 78,0	G1			A 312 053 02 30	<b>81-1609</b>
	IN [6]	15,04 x 9 x 72,0	G1			A 352 053 22 29	<b>81-1674</b>
						A 366 053 07 29	
	EX [6]	15,00 x 10 x 73,0	G1			A 352 053 16 30	<b>81-1658</b>
	EX [6]	15,04 x 10 x 67,0	G1			A 352 053 37 30	<b>81-1676</b>
						A 366 053 02 30	
	EX [6]	15,20 x 10 x 73,0	G1			A 352 053 18 30	<b>81-1659</b>

Fortsetzung nächste Seite / continued on next page / suite page suivante / continuación página próxima / Продолжение на следующей странице

					Reference	Item No.
IN [1]	45,08 x 37 x 8,3	G1 45°			A 352 053 16 31 A 352 053 22 31 A 352 053 31 31	<b>92-16112</b>
IN [1]	45,87 x 37 x 8,2	G1 45°			A 352 053 35 31 A 352 053 38 31 A 352 053 40 31	<b>92-16114</b>
EX [2]	38,07 x 30 x 8,5	G1 45°			A 366 053 16 32	<b>92-16109</b>
EX [1]	38,38 x 30 x 8,5	G1 45°			A 352 053 16 32 A 352 053 21 32	<b>92-16131</b>
	739 mm				A 352 050 49 01	<b>20 1003 35201 (1)</b>
	(1) Zahnrad angeschraubt/gear screwed on/pignon vissé/rueda dentada atornillada/зубчатое колесо привинчено					
[12]	M 28 x 60				A 352 054 05 01	<b>20 1003 35260</b>
<b>170</b>	<b>97</b>					
<b>OM 362</b>	<b>906, 909 - 910</b>	D (LA) 6	5675 cm <sup>3</sup> 2V	141 kW	(192 PS) 17:1	128,00 mm
93 750 6..	02.1983→					
IN [2]	42,0 x 9 x 140,5	A/S - Cr -	- 20° - -	5 - III	A 366 050 12 26	<b>261100</b>
IN [2]	42,0 x 9 x 140,5	A/S - Cr -	- 30° - -	5 - III	A 366 050 03 26	<b>16130</b>
IN [2]	43,0 x 9 x 140,5	A/S - Cr -	- 30° - -	5 - III	A 366 050 02 26	<b>16109</b>
IN [2]	44,0 x 9 x 140,5	A/S - Cr -	- 45° - -	5 - III	A 352 050 00 26 A 352 050 01 26 A 352 053 01 01	<b>16136</b>
EX [2]	36,0 x 10 x 140,5	A/S - Cr -	- 45° - -	5 - III	A 366 050 02 27	<b>16122</b>
EX [2]	36,0 x 10 x 140,6	A/S - Cr -	- 45° - -	5 - III	A 321 053 09 05 A 366 050 00 27 A 366 050 01 27 A 366 050 05 27 A 366 050 06 27 A 376 050 00 27 A 376 050 01 27	<b>16106</b>
IN [6]	15,00 x 9 x 78,0	G1			A 312 053 02 30	<b>81-1609</b>
IN [6]	15,03 x 9 x 72,0	G1			A 352 053 12 29	<b>81-1666</b>
IN [6]	15,04 x 9 x 72,0	G1			A 352 053 22 29 A 366 053 07 29	<b>81-1674</b>
EX [6]	15,03 x 10 x 67,0	G1			A 352 053 20 30	<b>81-1670</b>
EX [6]	15,04 x 10 x 67,0	G1			A 352 053 37 30 A 366 053 02 30	<b>81-1676</b>
IN [1]	43,87 x 34.5 x 7,4	G1			A 366 053 35 31	<b>92-16155</b>
IN [1]	43,87 x 34.5 x 7,8	G1 30°			A 366 053 09 31 A 366 053 12 31 A 366 053 14 31	<b>92-16153</b>
IN [1]	44,17 x 34.5 x 7,8	G1 30°			A 366 053 10 31	<b>92-16116</b>
EX [2]	38,07 x 30 x 8,5	G1 45°			A 366 053 16 32	<b>92-16109</b>
EX [1]	38,38 x 30 x 8,5	G1 45°			A 352 053 16 32 A 352 053 21 32	<b>92-16131</b>
	739 mm				A 366 050 04 01 A 366 050 06 01 A 366 051 11 01	<b>20 1003 36601</b>
[12]	M 28 x 60				A 352 054 05 01	<b>20 1003 35260</b>
I [1]					A 352 050 10 33 A 366 050 04 33	<b>20 1003 36602 (1)</b>
	(1) IN					

M



					Reference	Item No.
<b>171</b> <b>97</b>						
<b>OM 362</b>	<b>900/-500</b>					
93 750 6..	06.1984 →	D (LA)	6	5675 cm <sup>3</sup>	2V	128,00 mm (1)
(1) Shortblock						
	739 mm				A 352 050 49 01	<b>20 1003 35201</b> (2)
(2) Zahnrad angeschraubt/gear screwed on/pignon vissé/rueda dentada atornillada/зубчатое колесо привинчено						
[12]	M 28 x 60				A 352 054 05 01	<b>20 1003 35260</b>
I [1]					A 352 050 10 33 A 366 050 04 33	<b>20 1003 36602</b> (3)
(3) IN						
<b>172</b> <b>97</b>						
<b>OM 314</b>	<b>958, 960</b>					
90 274 8.., 93 882 6..		D (NA)	4	3782 cm <sup>3</sup>	2V 35-62 kW (48-84 PS) 17:1	128,00 mm
IN [2]	44,0 x 9 x 140,5	A/S - Cr -		- 45° -	5 - III	A 352 050 00 26 A 352 050 01 26 A 352 053 01 01 <b>16136</b>
EX [2]	36,0 x 10 x 140,5	S - Cr -		- 45° - VS -	5 - III	A 352 053 15 05 <b>1604</b>
IN [6]	15,00 x 9 x 78,0	G1				A 312 053 02 30 <b>81-1609</b>
IN [6]	15,03 x 9 x 72,0	G1				A 352 053 12 29 <b>81-1666</b>
EX [6]	15,00 x 10 x 73,0	G1				A 352 053 16 30 <b>81-1658</b>
EX [6]	15,03 x 10 x 67,0	G1				A 352 053 20 30 <b>81-1670</b>
EX [6]	15,04 x 10 x 67,0	G1				A 352 053 37 30 A 366 053 02 30 <b>81-1676</b>
EX [6]	15,20 x 10 x 73,0	G1				A 352 053 18 30 <b>81-1659</b>
IN [1]	45,08 x 37 x 8,3	G1 45°				A 352 053 16 31 A 352 053 22 31 A 352 053 31 31 <b>92-16112</b>
IN [1]	45,87 x 37 x 8,2	G1 45°				A 352 053 35 31 A 352 053 38 31 A 352 053 40 31 <b>92-16114</b>
EX [2]	38,07 x 30 x 8,5	G1 45°				A 366 053 16 32 <b>92-16109</b>
EX [1]	38,38 x 30 x 8,5	G1 45°				A 352 053 16 32 A 352 053 21 32 <b>92-16131</b>
[12]	M 28 x 60					A 352 054 05 01 <b>20 1003 35260</b>
<b>173</b> <b>97</b>						
<b>OM 340</b>	<b>919</b>					
		D	4	3780 cm <sup>3</sup>	2V 63 kW (86 PS) 17:1	128,00 mm
<b>OM 341</b>	<b>900</b>					
		D (NA)	6	5675 cm <sup>3</sup>	2V 74 kW (101 PS) 17:1	128,00 mm
<b>OM 343</b>	<b>919</b>					
		D	4	3780 cm <sup>3</sup>	2V 39 kW (53 PS) 17:1	128,00 mm
<b>OM 344</b>	<b>919</b>					
		D	6	5675 cm <sup>3</sup>	2V	128,00 mm
90 274 8.., 93 882 6..						
Fortsetzung nächste Seite / continued on next page / suite page suivante / continuación página próxima / Продолжение на следующей странице						

					Reference	Item No.
IN [1]	45,08 x 37 x 8,3	G1 45°			A 352 053 16 31 A 352 053 22 31 A 352 053 31 31	92-16112
IN [1]	45,87 x 37 x 8,2	G1 45°			A 352 053 35 31 A 352 053 38 31 A 352 053 40 31	92-16114
EX [2]	38,07 x 30 x 8,5	G1 45°			A 366 053 16 32	92-16109
EX [1]	38,38 x 30 x 8,5	G1 45°			A 352 053 16 32 A 352 053 21 32	92-16131
[12]	M 28 x 60				A 352 054 05 01	20 1003 35260

## 174 97

<b>OM 340</b>	<b>930, 932</b>	D (NA)	4	3780 cm <sup>3</sup>	2V	62-63 kW	(84-86 PS)	17:1	128,00 mm
<b>OM 343</b>	<b>910, 932</b>	D (NA)	4	3780 cm <sup>3</sup>	2V	62-63 kW	(84-86 PS)	17:1	128,00 mm

90 274 8.., 93 882 6..

IN [2]	43,0 x 9 x 140,5	A/S - Cr -	- 30° -	-	5 - III	A 366 050 02 26	16109
IN [2]	44,0 x 9 x 140,5	A/S - Cr -	- 45° -	-	5 - III	A 352 050 00 26 A 352 050 01 26 A 352 053 01 01	16136
EX [2]	36,0 x 10 x 140,5	A/S - Cr -	- 45° -	-	5 - III	A 366 050 02 27	16122
EX [2]	36,0 x 10 x 140,5	S - Cr -	- 45° -	VS -	5 - III	A 352 053 15 05	1604
EX [2]	36,0 x 10 x 140,6	A/S - Cr -	- 45° -	-	5 - III	A 321 053 09 05 A 366 050 00 27 A 366 050 01 27 A 366 050 05 27 A 366 050 06 27 A 376 050 00 27 A 376 050 01 27	16106
IN [6]	15,00 x 9 x 78,0	G1				A 312 053 02 30	81-1609
IN [6]	15,03 x 9 x 72,0	G1				A 352 053 12 29	81-1666
IN [6]	15,04 x 9 x 72,0	G1				A 352 053 22 29 A 366 053 07 29	81-1674
EX [6]	15,00 x 10 x 73,0	G1				A 352 053 16 30	81-1658
EX [6]	15,03 x 10 x 67,0	G1				A 352 053 20 30	81-1670
EX [6]	15,04 x 10 x 67,0	G1				A 352 053 37 30 A 366 053 02 30	81-1676
EX [6]	15,20 x 10 x 73,0	G1				A 352 053 18 30	81-1659
IN [1]	45,08 x 37 x 8,3	G1 45°				A 352 053 16 31 A 352 053 22 31 A 352 053 31 31	92-16112
IN [1]	45,87 x 37 x 8,2	G1 45°				A 352 053 35 31 A 352 053 38 31 A 352 053 40 31	92-16114
EX [2]	38,07 x 30 x 8,5	G1 45°				A 366 053 16 32	92-16109
EX [1]	38,38 x 30 x 8,5	G1 45°				A 352 053 16 32 A 352 053 21 32	92-16131
[12]	M 28 x 60					A 352 054 05 01	20 1003 35260

## 175 97

<b>OM 341</b>	<b>948, 951</b>	D (NA)	6	5675 cm <sup>3</sup>	2V	96 kW	(131 PS)	17:1	128,00 mm
---------------	-----------------	--------	---	----------------------	----	-------	----------	------	-----------

90 274 8.., 93 882 6..

Fortsetzung nächste Seite / continued on next page / suite page suivante / continuación página próxima / Продолжение на следующей странице

					Reference	Item No.	
	IN [2]	43,0 x 9 x 140,5	A/S - Cr -	- 30° - -	5 - III	A 366 050 02 26	<b>16109</b>
	IN [2]	44,0 x 9 x 140,5	A/S - Cr -	- 45° - -	5 - III	A 352 050 00 26 A 352 050 01 26 A 352 053 01 01	<b>16136</b>
	EX [2]	36,0 x 10 x 140,5	A/S - Cr -	- 45° - -	5 - III	A 366 050 02 27	<b>16122</b>
	EX [2]	36,0 x 10 x 140,5	S - Cr -	- 45° - VS -	5 - III	A 352 053 15 05	<b>1604</b>
	EX [2]	36,0 x 10 x 140,6	A/S - Cr -	- 45° - -	5 - III	A 321 053 09 05 A 366 050 00 27 A 366 050 01 27 A 366 050 05 27 A 366 050 06 27 A 376 050 00 27 A 376 050 01 27	<b>16106</b>
	IN [6]	15,00 x 9 x 78,0	G1			A 312 053 02 30	<b>81-1609</b>
	IN [6]	15,04 x 9 x 72,0	G1			A 352 053 22 29 A 366 053 07 29	<b>81-1674</b>
	EX [6]	15,00 x 10 x 73,0	G1			A 352 053 16 30	<b>81-1658</b>
	EX [6]	15,04 x 10 x 67,0	G1			A 352 053 37 30 A 366 053 02 30	<b>81-1676</b>
	EX [6]	15,20 x 10 x 73,0	G1			A 352 053 18 30	<b>81-1659</b>
	IN [1]	45,08 x 37 x 8,3	G1 45°			A 352 053 16 31 A 352 053 22 31 A 352 053 31 31	<b>92-16112</b>
	IN [1]	45,87 x 37 x 8,2	G1 45°			A 352 053 35 31 A 352 053 38 31 A 352 053 40 31	<b>92-16114</b>
	EX [2]	38,07 x 30 x 8,5	G1 45°			A 366 053 16 32	<b>92-16109</b>
	EX [1]	38,38 x 30 x 8,5	G1 45°			A 352 053 16 32 A 352 053 21 32	<b>92-16131</b>
		739 mm				A 352 050 49 01	<b>20 1003 35201 (1)</b>
		(1) Zahnrad angeschraubt/gear screwed on/pignon vissé/rueda dentada atornillada/зубчатое колесо привинчено					
	[12]	M 28 x 60				A 352 054 05 01	<b>20 1003 35260</b>

**176**
**97**
**OM 343**
**919-018**

D

4

3780 cm<sup>3</sup> 2V

53 kW

(72 PS) 17:1

128,00 mm

90 274 8.., 93 882 6..

	IN [6]	15,00 x 9 x 78,0	G1			A 312 053 02 30	<b>81-1609</b>
	IN [6]	15,03 x 9 x 72,0	G1			A 352 053 12 29	<b>81-1666</b>
	IN [6]	15,04 x 9 x 72,0	G1			A 352 053 22 29 A 366 053 07 29	<b>81-1674</b>
	EX [6]	15,00 x 10 x 73,0	G1			A 352 053 16 30	<b>81-1658</b>
	EX [6]	15,03 x 10 x 67,0	G1			A 352 053 20 30	<b>81-1670</b>
	EX [6]	15,04 x 10 x 67,0	G1			A 352 053 37 30 A 366 053 02 30	<b>81-1676</b>
	EX [6]	15,20 x 10 x 73,0	G1			A 352 053 18 30	<b>81-1659</b>
	IN [1]	45,08 x 37 x 8,3	G1 45°			A 352 053 16 31 A 352 053 22 31 A 352 053 31 31	<b>92-16112</b>
	IN [1]	45,87 x 37 x 8,2	G1 45°			A 352 053 35 31 A 352 053 38 31 A 352 053 40 31	<b>92-16114</b>
	EX [2]	38,07 x 30 x 8,5	G1 45°			A 366 053 16 32	<b>92-16109</b>
	EX [1]	38,38 x 30 x 8,5	G1 45°			A 352 053 16 32 A 352 053 21 32	<b>92-16131</b>

					Reference	Item No.		
<b>177</b>	<b>97</b>							
<b>OM 343</b>	<b>934</b>	D (NA)	4	3780 cm <sup>3</sup>	2V	63 kW (86 PS) 17:1	128,00 mm	
90 274 8.., 93 882 6..								
	IN [2]	44,0 x 9 x 140,5	A/S - Cr -	- 45° -	-	5 - III	A 352 050 00 26 A 352 050 01 26 A 352 053 01 01	<b>16136</b>
	EX [2]	36,0 x 10 x 140,5	A/S - Cr -	- 45° -	-	5 - III	A 366 050 02 27	<b>16122</b>
	EX [2]	36,0 x 10 x 140,5	S - Cr -	- 45° -	VS -	5 - III	A 352 053 15 05	<b>1604</b>
	EX [2]	36,0 x 10 x 140,6	A/S - Cr -	- 45° -	-	5 - III	A 321 053 09 05 A 366 050 00 27 A 366 050 01 27 A 366 050 05 27 A 366 050 06 27 A 376 050 00 27 A 376 050 01 27	<b>16106</b>
	IN [6]	15,00 x 9 x 78,0	G1				A 312 053 02 30	<b>81-1609</b>
	IN [6]	15,03 x 9 x 72,0	G1				A 352 053 12 29	<b>81-1666</b>
	IN [6]	15,04 x 9 x 72,0	G1				A 352 053 22 29 A 366 053 07 29	<b>81-1674</b>
	EX [6]	15,00 x 10 x 73,0	G1				A 352 053 16 30	<b>81-1658</b>
	EX [6]	15,03 x 10 x 67,0	G1				A 352 053 20 30	<b>81-1670</b>
	EX [6]	15,04 x 10 x 67,0	G1				A 352 053 37 30 A 366 053 02 30	<b>81-1676</b>
	EX [6]	15,20 x 10 x 73,0	G1				A 352 053 18 30	<b>81-1659</b>
	IN [1]	45,08 x 37 x 8,3	G1 45°				A 352 053 16 31 A 352 053 22 31 A 352 053 31 31	<b>92-16112</b>
	IN [1]	45,87 x 37 x 8,2	G1 45°				A 352 053 35 31 A 352 053 38 31 A 352 053 40 31	<b>92-16114</b>
	EX [2]	38,07 x 30 x 8,5	G1 45°				A 366 053 16 32	<b>92-16109</b>
	EX [1]	38,38 x 30 x 8,5	G1 45°				A 352 053 16 32 A 352 053 21 32	<b>92-16131</b>
	[12]	M 28 x 60					A 352 054 05 01	<b>20 1003 35260</b>
<b>178</b>	<b>97</b>							
<b>OM 344</b>	<b>930, 932</b>	D (NA)	6	5675 cm <sup>3</sup>	2V	96 kW (131 PS) 17:1	128,00 mm	
90 274 8.., 93 882 6..								
	IN [2]	43,0 x 9 x 140,5	A/S - Cr -	- 30° -	-	5 - III	A 366 050 02 26	<b>16109</b>
	IN [2]	44,0 x 9 x 140,5	A/S - Cr -	- 45° -	-	5 - III	A 352 050 00 26 A 352 050 01 26 A 352 053 01 01	<b>16136</b>
	EX [2]	36,0 x 10 x 140,5	A/S - Cr -	- 45° -	-	5 - III	A 366 050 02 27	<b>16122</b>
	EX [2]	36,0 x 10 x 140,5	S - Cr -	- 45° -	VS -	5 - III	A 352 053 15 05	<b>1604</b>
	EX [2]	36,0 x 10 x 140,6	A/S - Cr -	- 45° -	-	5 - III	A 321 053 09 05 A 366 050 00 27 A 366 050 01 27 A 366 050 05 27 A 366 050 06 27 A 376 050 00 27 A 376 050 01 27	<b>16106</b>
Fortsetzung nächste Seite / continued on next page / suite page suivante / continuación página próxima / Продолжение на следующей странице								

M

					Reference	Item No.
	IN [6]	15,00 x 9 x 78,0	G1		A 312 053 02 30	<b>81-1609</b>
	IN [6]	15,03 x 9 x 72,0	G1		A 352 053 12 29	<b>81-1666</b>
	IN [6]	15,04 x 9 x 72,0	G1		A 352 053 22 29	<b>81-1674</b>
					A 366 053 07 29	
	EX [6]	15,00 x 10 x 73,0	G1		A 352 053 16 30	<b>81-1658</b>
	EX [6]	15,04 x 10 x 67,0	G1		A 352 053 37 30	<b>81-1676</b>
	EX [6]	15,20 x 10 x 73,0	G1		A 366 053 02 30	
					A 352 053 18 30	<b>81-1659</b>
	IN [1]	45,08 x 37 x 8,3	G1 45°		A 352 053 16 31	<b>92-16112</b>
					A 352 053 22 31	
					A 352 053 31 31	
	IN [1]	45,87 x 37 x 8,2	G1 45°		A 352 053 35 31	
				A 352 053 38 31	<b>92-16114</b>	
				A 352 053 40 31		
	EX [2]	38,07 x 30 x 8,5	G1 45°		A 366 053 16 32	<b>92-16109</b>
	EX [1]	38,38 x 30 x 8,5	G1 45°		A 352 053 16 32	<b>92-16131</b>
					A 352 053 21 32	
		739 mm			A 352 050 49 01	<b>20 1003 35201 (1)</b>
		(1) Zahnrad angeschraubt/gear screwed on/pignon vissé/rueda dentada atornillada/зубчатое колесо привинчено				
	[12]	M 28 x 60			A 352 054 05 01	<b>20 1003 35260</b>

## 179 97

OM 353

922 - 923, 930 - 936, 938

D (NA) 6 5675 cm<sup>3</sup> 2V 62-88 kW (84-120 PS) 17:1 128,00 mm

OM 353

937

D (A) 6 5675 cm<sup>3</sup> 2V 92 kW (125 PS) 16:1 128,00 mm

90 274 8..., 90 276 7..., 92 581 6..., 93 882 6...

	IN [2]	44,0 x 9 x 140,5	A/S - Cr -	- 45° - -	5 - III	A 352 050 00 26	<b>16136</b>
						A 352 050 01 26	
						A 352 053 01 01	
	EX [2]	36,0 x 10 x 140,5	A/S - Cr -	- 45° - -	5 - III	A 366 050 02 27	
	EX [2]	36,0 x 10 x 140,5	S - Cr -	- 45° - VS -	5 - III	A 352 053 15 05	
	EX [2]	36,0 x 10 x 140,6	A/S - Cr -	- 45° - -	5 - III	A 321 053 09 05	<b>16106</b>
					A 366 050 00 27		
					A 366 050 01 27		
					A 366 050 05 27		
					A 366 050 06 27		
					A 376 050 00 27		
					A 376 050 01 27		
	IN [6]	15,00 x 9 x 78,0	G1			A 312 053 02 30	<b>81-1609</b>
	IN [6]	15,03 x 9 x 72,0	G1			A 352 053 12 29	<b>81-1666</b>
	IN [6]	15,04 x 9 x 72,0	G1			A 352 053 22 29	<b>81-1674</b>
						A 366 053 07 29	
	EX [6]	15,03 x 10 x 67,0	G1			A 352 053 20 30	<b>81-1670</b>
	EX [6]	15,04 x 10 x 67,0	G1			A 352 053 37 30	<b>81-1676</b>
					A 366 053 02 30		
	IN [1]	45,08 x 37 x 8,3	G1 45°			A 352 053 16 31	<b>92-16112</b>
						A 352 053 22 31	
						A 352 053 31 31	
	IN [1]	45,87 x 37 x 8,2	G1 45°			A 352 053 35 31	
					A 352 053 38 31	<b>92-16114</b>	
					A 352 053 40 31		
	EX [2]	38,07 x 30 x 8,5	G1 45°			A 366 053 16 32	<b>92-16109</b>
	EX [1]	38,38 x 30 x 8,5	G1 45°			A 352 053 16 32	<b>92-16131</b>
						A 352 053 21 32	

Fortsetzung nächste Seite / continued on next page / suite page suivante / continuación página próxima / Продолжение на следующей странице



					Reference	Item No.
[12]	M 28 x 60				A 352 054 05 01	20 1003 35260
I [1]					A 352 050 10 33 A 366 050 04 33	20 1003 36602 (1)
	(1) IN					

**180**
**97**
**OM 353**
**967**

D (NA) 6 5675 cm<sup>3</sup> 2V 74 kW (101 PS) 17:1 128,00 mm

90 274 8.., 93 882 6..

IN [2]	44,0 x 9 x 140,5	A/S - Cr -	- 45° - -	5 - III	A 352 050 00 26 A 352 050 01 26 A 352 053 01 01	<b>16136</b>
EX [2]	36,0 x 10 x 140,5	A/S - Cr -	- 45° - -	5 - III	A 366 050 02 27	<b>16122</b>
EX [2]	36,0 x 10 x 140,5	S - Cr -	- 45° - VS -	5 - III	A 352 053 15 05	<b>1604</b>
EX [2]	36,0 x 10 x 140,6	A/S - Cr -	- 45° - -	5 - III	A 321 053 09 05 A 366 050 00 27 A 366 050 01 27 A 366 050 05 27 A 366 050 06 27 A 376 050 00 27 A 376 050 01 27	<b>16106</b>
IN [6]	15,00 x 9 x 78,0	G1			A 312 053 02 30	<b>81-1609</b>
IN [6]	15,03 x 9 x 72,0	G1			A 352 053 12 29	<b>81-1666</b>
IN [6]	15,04 x 9 x 72,0	G1			A 352 053 22 29 A 366 053 07 29	<b>81-1674</b>
EX [6]	15,00 x 10 x 73,0	G1			A 352 053 16 30	<b>81-1658</b>
EX [6]	15,00 x 10 x 78,0	G1			A 321 053 12 30	<b>81-1631</b>
EX [6]	15,03 x 10 x 67,0	G1			A 352 053 20 30	<b>81-1670</b>
EX [6]	15,04 x 10 x 67,0	G1			A 352 053 37 30 A 366 053 02 30	<b>81-1676</b>
EX [6]	15,10 x 10 x 78,0	G1			A 321 053 13 30	<b>81-1632</b>
EX [6]	15,20 x 10 x 73,0	G1			A 352 053 18 30	<b>81-1659</b>
IN [1]	45,08 x 37 x 8,3	G1 45°			A 352 053 16 31 A 352 053 22 31 A 352 053 31 31	<b>92-16112</b>
IN [1]	45,87 x 37 x 8,2	G1 45°			A 352 053 35 31 A 352 053 38 31 A 352 053 40 31	<b>92-16114</b>
EX [2]	38,07 x 30 x 8,5	G1 45°			A 366 053 16 32	<b>92-16109</b>
EX [1]	38,38 x 30 x 8,5	G1 45°			A 352 053 16 32 A 352 053 21 32	<b>92-16131</b>
(1)	739 mm				A 352 050 49 01	20 1003 35201 (1)
	(1) Zahnrad angeschraubt/gear screwed on/pignon vissé/rueda dentada atornillada/зубчатое колесо привинчено					

**181**
**97**
**OM 396**
**900-017**

D 6 5675 cm<sup>3</sup> 2V 88 kW (120 PS) 17:1 128,00 mm

90 274 8.., 93 882 6..

Fortsetzung nächste Seite / continued on next page / suite page suivante / continuación página próxima / Продолжение на следующей странице

					Reference	Item No.
IN [2]	44,0 x 9 x 140,5	A/S - Cr -	- 45° - -	5 - III	A 352 050 00 26 A 352 050 01 26 A 352 053 01 01	<b>16136</b>
EX [2]	36,0 x 10 x 140,5	A/S - Cr -	- 45° - -	5 - III	A 366 050 02 27	<b>16122</b>
EX [2]	36,0 x 10 x 140,5	S - Cr -	- 45° - VS -	5 - III	A 352 053 15 05	<b>1604</b>
EX [2]	36,0 x 10 x 140,6	A/S - Cr -	- 45° - -	5 - III	A 321 053 09 05 A 366 050 00 27 A 366 050 01 27 A 366 050 05 27 A 366 050 06 27 A 376 050 00 27 A 376 050 01 27	<b>16106</b>
IN [6]	15,03 x 9 x 72,0	G1			A 352 053 12 29	<b>81-1666</b>
IN [6]	15,04 x 9 x 72,0	G1			A 352 053 22 29 A 366 053 07 29	<b>81-1674</b>
EX [6]	15,03 x 10 x 67,0	G1			A 352 053 20 30	<b>81-1670</b>
EX [6]	15,04 x 10 x 67,0	G1			A 352 053 37 30 A 366 053 02 30	<b>81-1676</b>
IN [1]	43,87 x 34.5 x 7,4	G1			A 366 053 35 31	<b>92-16155</b>
IN [1]	45,08 x 37 x 8,3	G1 45°			A 352 053 16 31 A 352 053 22 31 A 352 053 31 31	<b>92-16112</b>
IN [1]	45,87 x 37 x 8,2	G1 45°			A 352 053 35 31 A 352 053 38 31 A 352 053 40 31	<b>92-16114</b>
EX [2]	38,07 x 30 x 8,5	G1 45°			A 366 053 16 32	<b>92-16109</b>
EX [1]	38,38 x 30 x 8,5	G1 45°			A 352 053 16 32 A 352 053 21 32	<b>92-16131</b>

## 182

97,5

**M 376**
**922 - 924**

01.1964 →

G

(LA)

6

 5958 cm<sup>3</sup> 2V

155-157 kW

(211-214 PS)

133,00 mm



[12]

M 28 x 60

A 352 054 05 01

**20 1003 35260**

## 183

97,5

**M 372 Euro 0**
**924**

06.1973 →

G

6

 5958 cm<sup>3</sup> 2V

110 kW

(150 PS)

133,00 mm



IN [6]

15,04 x 9 x 72,0

G1

A 352 053 22 29

**81-1674**

EX [6]

15,04 x 10 x 67,0

G1

A 366 053 07 29

A 352 053 37 30

 A 366 053 02 30

| [12] | M 28 x 60 |  |  |  | A 352 054 05 01 | **20 1003 35260** |

## 184

97,5

**M 372 Euro 0**
**926 - 927, 929**

06.1973 →

G

6

 5958 cm<sup>3</sup> 2V

63-110 kW

(85-150 PS)

133,00 mm



IN [6]

15,04 x 9 x 72,0

G1

A 352 053 22 29

**81-1674**

EX [6]

15,04 x 10 x 67,0

G1

A 366 053 07 29

A 352 053 37 30

 A 366 053 02 30

|  | 739 mm |  |  |  | A 366 050 03 01 | **20 1003 36600** |
| [12] | M 28 x 60 |  |  |  | A 352 054 05 01 | **20 1003 35260** |

					Reference	Item No.
<b>185</b>		<b>97,5</b>				
<b>OM 366 Euro 1</b>	<b>911</b>		D (NA) 6	5958 cm <sup>3</sup> 2V	96 kW (131 PS) 19:1	133,00 mm
<b>OM 372 Euro 0</b>	<b>906 - 907</b>		D (NA) 6	5958 cm <sup>3</sup> 2V	100 kW (136 PS) 17,25:1	133,00 mm
<b>OM 376 Euro 0</b>	<b>905 - 909, 930</b>		D (NA) 6	5958 cm <sup>3</sup> 2V	95-100 kW (129-136 PS) 17,25:1	133,00 mm
91 550 6.., 91 551 6.., 93 951 6..						
	IN [2]	42,0 x 9 x 140,5	A/S - Cr -	- 20° -	5 - III	A 366 050 12 26 <b>261100</b>
	IN [2]	42,0 x 9 x 140,5	A/S - Cr -	- 30° -	5 - III	A 366 050 03 26 <b>16130</b>
	IN [2]	43,0 x 9 x 140,5	A/S - Cr -	- 30° -	5 - III	A 366 050 02 26 <b>16109</b>
	IN [2]	44,0 x 9 x 140,5	A/S - Cr -	- 45° -	5 - III	A 352 050 00 26 <b>16136</b>
						A 352 050 01 26
						A 352 053 01 01
	EX [2]	36,0 x 10 x 140,5	A/S - Cr -	- 45° -	5 - III	A 366 050 02 27 <b>16122</b>
	EX [2]	36,0 x 10 x 140,6	A/S - Cr -	- 45° -	5 - III	A 321 053 09 05 <b>16106</b>
						A 366 050 00 27
						A 366 050 01 27
						A 366 050 05 27
						A 366 050 06 27
						A 376 050 00 27
						A 376 050 01 27
	IN [6]	15,00 x 9 x 78,0	G1			A 312 053 02 30 <b>81-1609</b>
	IN [6]	15,04 x 9 x 72,0	G1			A 352 053 22 29 <b>81-1674</b>
						A 366 053 07 29
	EX [6]	15,04 x 10 x 67,0	G1			A 352 053 37 30 <b>81-1676</b>
						A 366 053 02 30
	IN [1]	43,87 x 34.5 x 7,4	G1			A 366 053 35 31 <b>92-16155</b>
	IN [1]	43,87 x 34.5 x 7,8	G1 30°			A 366 053 09 31 <b>92-16153</b>
						A 366 053 12 31
						A 366 053 14 31
	IN [1]	44,17 x 34.5 x 7,8	G1 30°			A 366 053 10 31 <b>92-16116</b>
	EX [2]	38,07 x 30 x 7,9	G1 45°			A 366 053 20 32 <b>92-16154</b>
	EX [2]	38,07 x 30 x 8,5	G1 45°			A 366 053 16 32 <b>92-16109</b>
	EX [1]	38,38 x 30 x 8,5	G1 45°			A 352 053 16 32 <b>92-16131</b>
						A 352 053 21 32
		739 mm				A 366 050 03 01 <b>20 1003 36600</b>
	[12]	M 28 x 60				A 352 054 05 01 <b>20 1003 35260</b>
<b>186</b>		<b>97,5</b>				
<b>OM 376 Euro 0</b>	<b>945 - 947, 950 - 958, 961 - 962, 964, 967</b>		D (A) 6	5958 cm <sup>3</sup> 2V	125-135 kW (170-184 PS) 16,5:1	133,00 mm
01.1964 →						
90 532 6.., 93 831 6..						
Fortsetzung nächste Seite / continued on next page / suite page suivante / continuación página próxima / Продолжение на следующей странице						

M

					Reference	Item No.	
	IN [2]	42,0 x 9 x 140,5	A/S - Cr -	- 20° - -	5 - III	A 366 050 12 26	<b>261100</b>
	IN [2]	42,0 x 9 x 140,5	A/S - Cr -	- 30° - -	5 - III	A 366 050 03 26	<b>16130</b>
	IN [2]	43,0 x 9 x 140,5	A/S - Cr -	- 30° - -	5 - III	A 366 050 02 26	<b>16109</b>
	IN [2]	44,0 x 9 x 140,5	A/S - Cr -	- 45° - -	5 - III	A 352 050 00 26 A 352 050 01 26 A 352 053 01 01	<b>16136</b>
	EX [2]	36,0 x 10 x 140,5	A/S - Cr -	- 45° - -	5 - III	A 366 050 02 27	<b>16122</b>
	EX [2]	36,0 x 10 x 140,5	S - Cr -	- 45° - VS -	5 - III	A 352 053 15 05	<b>1604</b>
	EX [2]	36,0 x 10 x 140,6	A/S - Cr -	- 45° - -	5 - III	A 321 053 09 05 A 366 050 00 27 A 366 050 01 27 A 366 050 05 27 A 366 050 06 27 A 376 050 00 27 A 376 050 01 27	<b>16106</b>
	IN [6]	15,00 x 9 x 78,0	G1			A 312 053 02 30	<b>81-1609</b>
	IN [6]	15,04 x 9 x 72,0	G1			A 352 053 22 29 A 366 053 07 29	<b>81-1674</b>
	EX [6]	15,04 x 10 x 67,0	G1			A 352 053 37 30 A 366 053 02 30	<b>81-1676</b>
	IN [1]	43,87 x 34,5 x 7,4	G1			A 366 053 35 31	<b>92-16155</b>
	EX [2]	38,07 x 30 x 7,9	G1 45°			A 366 053 20 32	<b>92-16154</b>
	EX [2]	38,07 x 30 x 8,5	G1 45°			A 366 053 16 32	<b>92-16109</b>
	EX [1]	38,38 x 30 x 8,5	G1 45°			A 352 053 16 32 A 352 053 21 32	<b>92-16131</b>
	739 mm				A 366 050 04 01 A 366 050 06 01 A 366 051 11 01	<b>20 1003 36601</b>	
	[12] M 28 x 60				A 352 054 05 01	<b>20 1003 35260</b>	
	I [1]				A 352 050 10 33 A 366 050 04 33	<b>20 1003 36602 (1)</b>	
	(1) IN						

## 187 97,5

<b>OM 377 Euro 0</b>	<b>960, 962 - 964, 967 - 969, 972 - 973, 980 - 985</b>	D (LA)	6	5958 cm <sup>3</sup>	2V	140-170 kW	(190-231 PS)	16,5:1	133,00 mm
<b>OM 377 Euro 0</b>	<b>940 - 943, 945</b>	D (A)	6	5958 cm <sup>3</sup>	2V	125 kW	(170 PS)	16,5:1	133,00 mm
	01.1966 →								

	IN [2]	42,0 x 9 x 140,5	A/S - Cr -	- 20° - -	5 - III	A 366 050 12 26	<b>261100</b>
	IN [2]	42,0 x 9 x 140,5	A/S - Cr -	- 30° - -	5 - III	A 366 050 03 26	<b>16130</b>
	IN [2]	43,0 x 9 x 140,5	A/S - Cr -	- 30° - -	5 - III	A 366 050 02 26	<b>16109</b>
	IN [2]	44,0 x 9 x 140,5	A/S - Cr -	- 45° - -	5 - III	A 352 050 00 26 A 352 050 01 26 A 352 053 01 01	<b>16136</b>
	EX [2]	36,0 x 10 x 140,5	A/S - Cr -	- 45° - -	5 - III	A 366 050 02 27	<b>16122</b>
	EX [2]	36,0 x 10 x 140,6	A/S - Cr -	- 45° - -	5 - III	A 321 053 09 05 A 366 050 00 27 A 366 050 01 27 A 366 050 05 27 A 366 050 06 27 A 376 050 00 27 A 376 050 01 27	<b>16106</b>
		IN [6]	15,04 x 9 x 72,0	G1			A 352 053 22 29 A 366 053 07 29
EX [6]		15,04 x 10 x 67,0	G1			A 352 053 37 30 A 366 053 02 30	<b>81-1676</b>

Fortsetzung nächste Seite / continued on next page / suite page suivante / continuación página próxima / Продолжение на следующей странице

					Reference	Item No.
IN [1] EX [2] EX [2] EX [1]	43,87 x 34.5 x 7,4 38,07 x 30 x 7,9 38,07 x 30 x 8,5 38,38 x 30 x 8,5	G1 G1 45° G1 45° G1 45°			A 366 053 35 31 A 366 053 20 32 A 366 053 16 32 A 352 053 16 32 A 352 053 21 32	<b>92-16155</b> <b>92-16154</b> <b>92-16109</b> <b>92-16131</b>
[12]	M 28 x 60				A 352 054 05 01	<b>20 1003 35260</b>
I [1]  (1) IN					A 352 050 10 33 A 366 050 04 33	<b>20 1003 36602 (1)</b>

## 188 97,5

<b>OM 370 Euro 0</b>	<b>905</b>								
	07.1964 →	D (NA)	4	3972 cm <sup>3</sup>	2V	66 kW	(90 PS)	17,25:1	133,00 mm
<b>OM 374 Euro 0</b>	<b>900, 905, 908</b>								
	07.1964 →	D (NA)	4	3972 cm <sup>3</sup>	2V	42-66 kW	(57-90 PS)		133,00 mm
<b>OM 374 Euro 0</b>	<b>907</b>								
	93 951 6..	D	4	3972 cm <sup>3</sup>	2V	66 kW	(90 PS)	17,25:1	133,00 mm

IN [2] IN [2]	43,0 x 9 x 140,5 44,0 x 9 x 140,5	A/S - Cr - A/S - Cr -	- 30° - - 45° -	- -	5 - III 5 - III	A 366 050 02 26 A 352 050 00 26 A 352 050 01 26 A 352 053 01 01	<b>16109</b> <b>16136</b>
EX [2] EX [2]	36,0 x 10 x 140,5 36,0 x 10 x 140,6	A/S - Cr - A/S - Cr -	- 45° - - 45° -	- -	5 - III 5 - III	A 366 050 02 27 A 321 053 09 05 A 366 050 00 27 A 366 050 01 27 A 366 050 05 27 A 366 050 06 27 A 376 050 00 27 A 376 050 01 27	<b>16122</b> <b>16106</b>
IN [6] IN [6]	15,00 x 9 x 78,0 15,04 x 9 x 72,0	G1 G1				A 312 053 02 30 A 352 053 22 29 A 366 053 07 29	<b>81-1609</b> <b>81-1674</b>
EX [6]	15,04 x 10 x 67,0	G1				A 352 053 37 30 A 366 053 02 30	<b>81-1676</b>
IN [1]  IN [1] EX [2] EX [1]	43,87 x 34.5 x 7,8  44,17 x 34.5 x 7,8 38,07 x 30 x 8,5 38,38 x 30 x 8,5	G1 30°  G1 30° G1 45° G1 45°				A 366 053 09 31 A 366 053 12 31 A 366 053 14 31 A 366 053 10 31 A 366 053 16 32 A 352 053 16 32 A 352 053 21 32	<b>92-16153</b>  <b>92-16116</b> <b>92-16109</b> <b>92-16131</b>
						A 364 050 03 01	<b>20 1003 36400</b>
[12]	M 28 x 60					A 352 054 05 01	<b>20 1003 35260</b>

M



					Reference	Item No.
<b>189</b>		<b>97,5</b>				
<b>OM 374 Euro 0</b>	<b>976 - 979</b>					
	07.1964 →	D	4	3972 cm <sup>3</sup>	2V	85-100 kW (115-136 PS) 16,5:1 133,00 mm
<b>OM 374</b>	<b>992</b>					
	07.1964 →	D (NA)	4	3972 cm <sup>3</sup>	2V	80 kW (109 PS) 16,5:1 133,00 mm
<b>OM 374 991</b>						
	07.1964 →	D (LA)	4	3972 cm <sup>3</sup>	2V	81 kW (110 PS) 16,5:1 133,00 mm
<b>OM 374 993</b>						
	07.1964 →	D (LA)	4	3972 cm <sup>3</sup>	2V	81 kW (110 PS) 16,5:1 133,00 mm
<b>OM 374 994</b>						
	06.1985 →	D (LA)	4	3972 cm <sup>3</sup>	2V	81 kW (110 PS) 16,5:1 133,00 mm
<b>OM 374 996</b>						
	07.1964 →	D (LA)	4	3972 cm <sup>3</sup>	2V	85 kW (115 PS) 16,5:1 133,00 mm
<b>OM 374 997</b>						
		D (LA)	4	3972 cm <sup>3</sup>	2V	68 kW (93 PS) 16,5:1 133,00 mm
<b>OM 376 Euro 0</b>	<b>911-511, 911-512, 911-513, 911-514</b>					
		D (LA)	6	5958 cm <sup>3</sup>	2V	127-172 kW (170-230 PS) 16,5:1 133,00 mm
<b>OM 377 Euro 0</b>	<b>986</b>					
	07.1985 →	D (LA)	6	5958 cm <sup>3</sup>	2V	155 kW (211 PS) 16,5:1 133,00 mm
<b>OM 390 Euro 0</b>	<b>900-505 (AMS), 900-506, 900-508 (AMS), 900-510, 900-511, 900-512, 900-513, 900-515, 900-516, 900-517, 900-518, 900-519, 900-521, 900-522, 900-523, 900-537, 900-539, 900-547, 900-549, 900-550</b>					
		D (LA)	6	5958 cm <sup>3</sup>	2V	127-156 kW (170-212 PS) 16,5:1 133,00 mm
<b>OM 390 Euro 0</b>	<b>900-006 (AMS), 900-007, 900-405 (AMS), 900-407</b>					
	01.1984 → 12.1998	D (A)	6	5958 cm <sup>3</sup>	2V	100-127 kW (136-173 PS) 16,5:1 133,00 mm
90 532 6..., 93 831 6..						
	I [1]					A 352 050 10 33 A 366 050 04 33
	(1) IN					<b>20 1003 36602</b> (1)

<b>190</b>		<b>97,5</b>				
<b>OM 356 Euro 1</b>	<b>977 - 981, 983, 986 - 987, 989 - 998</b>					
	01.1991 →	D (LA)	6	5958 cm <sup>3</sup>	2V	127-177 kW (170-240 PS) 133,00 mm
<b>OM 356 Euro 1</b>	<b>940 - 941, 943, 945 - 959</b>					
	01.1970 →	D (A)	6	5958 cm <sup>3</sup>	2V	92-129 kW (125-175 PS) 133,00 mm
<b>OM 356 Euro 0</b>	<b>984 - 985</b>					
	02.1990 →	D (LA)	6	5958 cm <sup>3</sup>	2V	150-155 kW (204-211 PS) 16,5:1 133,00 mm
<b>OM 357 Euro 2</b>	<b>900 - 904, 906 - 910, 915 - 922, 925, 927, 929 - 933, 936 - 938, 940 - 944, 947 - 949, 961 - 963</b>					
	09.1967 →	D (LA)	6	5958 cm <sup>3</sup>	2V	125-177 kW (170-240 PS) 133,00 mm
<b>OM 366 Euro 0</b>	<b>980 - 981, 983 - 984, 988, 990, 992 - 996</b>					
		D (LA)	6	5958 cm <sup>3</sup>	2V	148-157 kW (201-214 PS) 133,00 mm
<b>OM 366 Euro 0</b>	<b>947 - 949, 954 - 956, 958, 963, 977</b>					
	02.1982 →	D (A)	6	5958 cm <sup>3</sup>	2V	92-132 kW (125-180 PS) 16,5:1 133,00 mm
<b>OM 366 Euro 1</b>	<b>941 - 943</b>					
		D (A)	6	5958 cm <sup>3</sup>	2V	116-121 kW (158-165 PS) 18:1 133,00 mm
<b>OM 366 Euro 1</b>	<b>997, 999</b>					
	03.1986 →	D (LA)	6	5958 cm <sup>3</sup>	2V	148-170 kW (201-231 PS) 133,00 mm
<b>OM 372 Euro 0</b>	<b>980 - 982</b>					
		D (LA)	6	5958 cm <sup>3</sup>	2V	150 kW (204 PS) 16,5:1 133,00 mm
<b>OM 372 Euro 0</b>	<b>950 - 951, 953, 956, 959, 961 - 962</b>					
		D (A)	6	5958 cm <sup>3</sup>	2V	100-135 kW (136-184 PS) 133,00 mm
90 532 6..., 91 598 6..., 92 525 7..., 93 831 6..., 93 951 6..., 94 333 6..						

Fortsetzung nächste Seite / continued on next page / suite page suivante / continuación página próxima / Продолжение на следующей странице

					Reference	Item No.	
	IN [2]	42,0 x 9 x 140,5	A/S - Cr -	- 20° - -	5 - III	A 366 050 12 26	<b>261100</b>
	IN [2]	42,0 x 9 x 140,5	A/S - Cr -	- 30° - -	5 - III	A 366 050 03 26	<b>16130</b>
	IN [2]	43,0 x 9 x 140,5	A/S - Cr -	- 30° - -	5 - III	A 366 050 02 26	<b>16109</b>
	IN [2]	44,0 x 9 x 140,5	A/S - Cr -	- 45° - -	5 - III	A 352 050 00 26	<b>16136</b>
						A 352 050 01 26	
						A 352 053 01 01	
	EX [2]	36,0 x 10 x 140,5	A/S - Cr -	- 45° - -	5 - III	A 366 050 02 27	<b>16122</b>
	EX [2]	36,0 x 10 x 140,6	A/S - Cr -	- 45° - -	5 - III	A 321 053 09 05	<b>16106</b>
						A 366 050 00 27	
						A 366 050 01 27	
					A 366 050 05 27		
					A 366 050 06 27		
					A 376 050 00 27		
					A 376 050 01 27		
	IN [6]	15,00 x 9 x 78,0	G1			A 312 053 02 30	<b>81-1609</b>
	IN [6]	15,04 x 9 x 72,0	G1			A 352 053 22 29	<b>81-1674</b>
	EX [6]	15,04 x 10 x 67,0	G1			A 366 053 07 29	<b>81-1676</b>
					A 352 053 37 30		
					A 366 053 02 30		
	IN [1]	43,87 x 34,5 x 7,4	G1			A 366 053 35 31	<b>92-16155</b>
	EX [2]	38,07 x 30 x 7,9	G1 45°			A 366 053 20 32	<b>92-16154</b>
	EX [2]	38,07 x 30 x 8,5	G1 45°			A 366 053 16 32	<b>92-16109</b>
	EX [1]	38,38 x 30 x 8,5	G1 45°			A 352 053 16 32	<b>92-16131</b>
					A 352 053 21 32		
		739 mm				A 366 050 04 01	<b>20 1003 36601</b>
						A 366 050 06 01	
						A 366 051 11 01	
	[12]	M 28 x 60				A 352 054 05 01	<b>20 1003 35260</b>
	I [1]					A 352 050 10 33	<b>20 1003 36602 (1)</b>
	(1) IN					A 366 050 04 33	

## 191 97,5

<b>OM 374 Euro 0</b>	<b>981 - 982</b>								
	03.1984 → 12.1998	D (A)	4	3972 cm <sup>3</sup>	2V	104 kW	(140 PS)	16,5:1	133,00 mm
<b>OM 376 Euro 0</b>	<b>968 - 970, 972, 975 - 977, 995, 997</b>								
	01.1966 →	D (LA)	6	5958 cm <sup>3</sup>	2V	127-156 kW	(173-212 PS)	16,5:1	133,00 mm
<b>OM 376 Euro 0</b>	<b>911</b>								
		D (A)	6	5958 cm <sup>3</sup>	2V	66-172 kW	(90-234 PS)	16,5:1	133,00 mm

	IN [2]	42,0 x 9 x 140,5	A/S - Cr -	- 20° - -	5 - III	A 366 050 12 26	<b>261100</b>
	IN [2]	42,0 x 9 x 140,5	A/S - Cr -	- 30° - -	5 - III	A 366 050 03 26	<b>16130</b>
	IN [2]	43,0 x 9 x 140,5	A/S - Cr -	- 30° - -	5 - III	A 366 050 02 26	<b>16109</b>
	IN [2]	44,0 x 9 x 140,5	A/S - Cr -	- 45° - -	5 - III	A 352 050 00 26	<b>16136</b>
						A 352 050 01 26	
						A 352 053 01 01	
	EX [2]	36,0 x 10 x 140,5	A/S - Cr -	- 45° - -	5 - III	A 366 050 02 27	<b>16122</b>
	EX [2]	36,0 x 10 x 140,5	S - Cr -	- 45° - VS -	5 - III	A 352 053 15 05	<b>1604</b>
	EX [2]	36,0 x 10 x 140,6	A/S - Cr -	- 45° - -	5 - III	A 321 053 09 05	<b>16106</b>
						A 366 050 00 27	
					A 366 050 01 27		
					A 366 050 05 27		
					A 366 050 06 27		
					A 376 050 00 27		
					A 376 050 01 27		

Fortsetzung nächste Seite / continued on next page / suite page suivante / continuación página próxima / Продолжение на следующей странице

					Reference	Item No.
	IN [6]	15,00 x 9 x 78,0	G1		A 312 053 02 30	<b>81-1609</b>
	IN [6]	15,04 x 9 x 72,0	G1		A 352 053 22 29 A 366 053 07 29	<b>81-1674</b>
	EX [6]	15,04 x 10 x 67,0	G1		A 352 053 37 30 A 366 053 02 30	<b>81-1676</b>
	IN [1]	43,87 x 34,5 x 7,4	G1		A 366 053 35 31	<b>92-16155</b>
	EX [2]	38,07 x 30 x 7,9	G1 45°		A 366 053 20 32	<b>92-16154</b>
	EX [2]	38,07 x 30 x 8,5	G1 45°		A 366 053 16 32	<b>92-16109</b>
	EX [1]	38,38 x 30 x 8,5	G1 45°		A 352 053 16 32 A 352 053 21 32	<b>92-16131</b>
	[12]	M 28 x 60			A 352 054 05 01	<b>20 1003 35260</b>
	I [1]				A 352 050 10 33 A 366 050 04 33	<b>20 1003 36602 (1)</b>
	(1) IN					

## 192 97,5

<b>OM 356 Euro 1</b>	<b>988</b>		D (LA)	6	5958 cm <sup>3</sup>	2V	177 kW	(241 PS)	16,5:1	133,00 mm
<b>OM 357 Euro 2</b>	<b>926</b>		D (LA)	6	5958 cm <sup>3</sup>	2V	155 kW	(211 PS)	18:1	133,00 mm
09.1969 →										
92 525 7.., 94 333 6..										

	IN [2]	42,0 x 9 x 140,5	A/S - Cr -	- 20° -	-	5 - III	A 366 050 12 26	<b>261100</b> <b>16106</b>
	EX [2]	36,0 x 10 x 140,6	A/S - Cr -	- 45° -	-	5 - III	A 321 053 09 05 A 366 050 00 27 A 366 050 01 27 A 366 050 05 27 A 366 050 06 27 A 376 050 00 27 A 376 050 01 27	
	IN [6]	15,00 x 9 x 78,0	G1				A 312 053 02 30	<b>81-1609</b>
	IN [6]	15,04 x 9 x 72,0	G1				A 352 053 22 29 A 366 053 07 29	<b>81-1674</b>
	EX [6]	15,04 x 10 x 67,0	G1				A 352 053 37 30 A 366 053 02 30	<b>81-1676</b>
	IN [1]	43,87 x 34,5 x 7,4	G1				A 366 053 35 31	<b>92-16155</b>
	EX [2]	38,07 x 30 x 7,9	G1 45°				A 366 053 20 32	<b>92-16154</b>
	[12]	M 28 x 60					A 352 054 05 01	<b>20 1003 35260</b>
	I [1]						A 352 050 10 33 A 366 050 04 33	<b>20 1003 36602 (1)</b>
	(1) IN							

## 193 97,5

<b>OM 372 Euro 0</b>	<b>958, 960, 964</b>		D (A)	6	5958 cm <sup>3</sup>	2V	125 kW	(170 PS)	16,5:1	133,00 mm
<b>OM 372 Euro 0</b>	<b>983 - 985, 987</b>		D (LA)	6	5958 cm <sup>3</sup>	2V	150-155 kW	(204-211 PS)	16,5:1	133,00 mm
<b>OM 376 Euro 0</b>	<b>941</b>		D (LA)	6	5958 cm <sup>3</sup>	2V	150 kW	(204 PS)	17,25:1	133,00 mm
90 532 6.., 93 831 6..										

Fortsetzung nächste Seite / continued on next page / suite page suivante / continuación página próxima / Продолжение на следующей странице

					Reference	Item No.	
	IN [2]	42,0 x 9 x 140,5	A/S - Cr -	- 20° - -	5 - III	A 366 050 12 26	<b>261100</b>
	IN [2]	42,0 x 9 x 140,5	A/S - Cr -	- 30° - -	5 - III	A 366 050 03 26	<b>16130</b>
	IN [2]	43,0 x 9 x 140,5	A/S - Cr -	- 30° - -	5 - III	A 366 050 02 26	<b>16109</b>
	IN [2]	44,0 x 9 x 140,5	A/S - Cr -	- 45° - -	5 - III	A 352 050 00 26	<b>16136</b>
						A 352 050 01 26	
						A 352 053 01 01	
	EX [2]	36,0 x 10 x 140,5	A/S - Cr -	- 45° - -	5 - III	A 366 050 02 27	<b>16122</b>
	EX [2]	36,0 x 10 x 140,6	A/S - Cr -	- 45° - -	5 - III	A 321 053 09 05	<b>16106</b>
						A 366 050 00 27	
						A 366 050 01 27	
					A 366 050 05 27		
					A 366 050 06 27		
					A 376 050 00 27		
					A 376 050 01 27		
	IN [6]	15,00 x 9 x 78,0	G1			A 312 053 02 30	<b>81-1609</b>
	IN [6]	15,04 x 9 x 72,0	G1			A 352 053 22 29	<b>81-1674</b>
	EX [6]	15,04 x 10 x 67,0	G1			A 366 053 07 29	<b>81-1676</b>
					A 352 053 37 30		
					A 366 053 02 30		
	IN [1]	43,87 x 34.5 x 7,4	G1			A 366 053 35 31	<b>92-16155</b>
	EX [2]	38,07 x 30 x 7,9	G1 45°			A 366 053 20 32	<b>92-16154</b>
	EX [2]	38,07 x 30 x 8,5	G1 45°			A 366 053 16 32	<b>92-16109</b>
	EX [1]	38,38 x 30 x 8,5	G1 45°			A 352 053 16 32	<b>92-16131</b>
					A 352 053 21 32		
	[12]	M 28 x 60				A 352 054 05 01	<b>20 1003 35260</b>
	I [1]					A 352 050 10 33	<b>20 1003 36602 (1)</b>
						A 366 050 04 33	
	(1) IN						

## 194 97,5

<b>OM 372 Euro 0</b>	<b>986</b>								
	09.1969 →	D (LA)	6	5958 cm <sup>3</sup>	2V	155 kW	(211 PS)	16,5:1	133,00 mm
<b>OM 374 Euro 0</b>	<b>987</b>								
		D (A)	4	3972 cm <sup>3</sup>	2V	104 kW	(140 PS)	16,5:1	133,00 mm

	IN [2]	42,0 x 9 x 140,5	A/S - Cr -	- 20° - -	5 - III	A 366 050 12 26	<b>261100</b>
	IN [2]	42,0 x 9 x 140,5	A/S - Cr -	- 30° - -	5 - III	A 366 050 03 26	<b>16130</b>
	IN [2]	43,0 x 9 x 140,5	A/S - Cr -	- 30° - -	5 - III	A 366 050 02 26	<b>16109</b>
	IN [2]	44,0 x 9 x 140,5	A/S - Cr -	- 45° - -	5 - III	A 352 050 00 26	<b>16136</b>
						A 352 050 01 26	
						A 352 053 01 01	
	EX [2]	36,0 x 10 x 140,5	A/S - Cr -	- 45° - -	5 - III	A 366 050 02 27	<b>16122</b>
	EX [2]	36,0 x 10 x 140,6	A/S - Cr -	- 45° - -	5 - III	A 321 053 09 05	<b>16106</b>
						A 366 050 00 27	
						A 366 050 01 27	
					A 366 050 05 27		
					A 366 050 06 27		
					A 376 050 00 27		
					A 376 050 01 27		
	IN [6]	15,00 x 9 x 78,0	G1			A 312 053 02 30	<b>81-1609</b>
	IN [6]	15,04 x 9 x 72,0	G1			A 352 053 22 29	<b>81-1674</b>
	EX [6]	15,04 x 10 x 67,0	G1			A 366 053 07 29	<b>81-1676</b>
					A 352 053 37 30		
					A 366 053 02 30		
	IN [1]	43,87 x 34.5 x 7,4	G1			A 366 053 35 31	<b>92-16155</b>
	EX [2]	38,07 x 30 x 7,9	G1 45°			A 366 053 20 32	<b>92-16154</b>
	[12]	M 28 x 60				A 352 054 05 01	<b>20 1003 35260</b>

Fortsetzung nächste Seite / continued on next page / suite page suivante / continuación página próxima / Продолжение на следующей странице

					Reference	Item No.
I [1]	(1) IN				A 352 050 10 33 A 366 050 04 33	<b>20 1003 36602</b> (1)

## 195 97,5

**OM 366 Euro 0** 944 - 946, 951 - 953, 957, 962, 965 - 971, 973 - 974, 976, 978 - 979  
 01.1970 → D (A) 6 5958 cm<sup>3</sup> 2V 116-129 kW (158-175 PS) 16,5:1 133,00 mm  
 90 532 6.., 93 831 6..

IN [2]	42,0 x 9 x 140,5	A/S - Cr -	- 20° - -	5 - III	A 366 050 12 26	<b>261100</b>
IN [2]	42,0 x 9 x 140,5	A/S - Cr -	- 30° - -	5 - III	A 366 050 03 26	<b>16130</b>
IN [2]	43,0 x 9 x 140,5	A/S - Cr -	- 30° - -	5 - III	A 366 050 02 26	<b>16109</b>
IN [2]	44,0 x 9 x 140,5	A/S - Cr -	- 45° - -	5 - III	A 352 050 00 26 A 352 050 01 26 A 352 053 01 01	<b>16136</b>
EX [2]	36,0 x 10 x 140,5	A/S - Cr -	- 45° - -	5 - III	A 366 050 02 27	<b>16122</b>
EX [2]	36,0 x 10 x 140,6	A/S - Cr -	- 45° - -	5 - III	A 321 053 09 05 A 366 050 00 27 A 366 050 01 27 A 366 050 05 27 A 366 050 06 27 A 376 050 00 27 A 376 050 01 27	<b>16106</b>
IN [6]	15,00 x 9 x 78,0	G1			A 312 053 02 30	<b>81-1609</b>
IN [6]	15,04 x 9 x 72,0	G1			A 352 053 22 29 A 366 053 07 29	<b>81-1674</b>
EX [6]	15,04 x 10 x 67,0	G1			A 352 053 37 30 A 366 053 02 30	<b>81-1676</b>
IN [1]	43,87 x 34.5 x 7,4	G1			A 366 053 35 31	<b>92-16155</b>
IN [1]	43,87 x 34.5 x 7,8	G1 30°			A 366 053 09 31 A 366 053 12 31 A 366 053 14 31	<b>92-16153</b>
EX [2]	38,07 x 30 x 7,9	G1 45°			A 366 053 20 32	<b>92-16154</b>
EX [2]	38,07 x 30 x 8,5	G1 45°			A 366 053 16 32	<b>92-16109</b>
EX [1]	38,38 x 30 x 8,5	G1 45°			A 352 053 16 32 A 352 053 21 32	<b>92-16131</b>
	739 mm				A 366 050 04 01 A 366 050 06 01 A 366 051 11 01	<b>20 1003 36601</b>
[12]	M 28 x 60				A 352 054 05 01	<b>20 1003 35260</b>
I [1]	(1) IN				A 352 050 10 33 A 366 050 04 33	<b>20 1003 36602</b> (1)

## 196 97,5

**OM 386 Euro 0** 980 - 981, 983  
 01.1970 → D (LA) 6 5958 cm<sup>3</sup> 2V 150 kW (204 PS) 16,5:1 133,00 mm  
**OM 386 Euro 0** 950 - 952  
 01.1970 → D (A) 6 5958 cm<sup>3</sup> 2V 125 kW (170 PS) 16,5:1 133,00 mm  
 90 532 6.., 93 831 6..

Fortsetzung nächste Seite / continued on next page / suite page suivante / continuación página próxima / Продолжение на следующей странице



					Reference	Item No.	
	IN [2]	42,0 x 9 x 140,5	A/S - Cr -	- 30° - -	5 - III	A 366 050 03 26	<b>16130</b>
	IN [2]	43,0 x 9 x 140,5	A/S - Cr -	- 30° - -	5 - III	A 366 050 02 26	<b>16109</b>
	IN [2]	44,0 x 9 x 140,5	A/S - Cr -	- 45° - -	5 - III	A 352 050 00 26	<b>16136</b>
						A 352 050 01 26	
						A 352 053 01 01	
	EX [2]	36,0 x 10 x 140,5	A/S - Cr -	- 45° - -	5 - III	A 366 050 02 27	<b>16122</b>
	EX [2]	36,0 x 10 x 140,5	S - Cr -	- 45° - VS -	5 - III	A 352 053 15 05	<b>1604</b>
	EX [2]	36,0 x 10 x 140,6	A/S - Cr -	- 45° - -	5 - III	A 321 053 09 05	<b>16106</b>
						A 366 050 00 27	
						A 366 050 01 27	
					A 366 050 05 27		
					A 366 050 06 27		
					A 376 050 00 27		
					A 376 050 01 27		
	IN [6]	15,00 x 9 x 78,0	G1			A 312 053 02 30	<b>81-1609</b>
	IN [6]	15,04 x 9 x 72,0	G1			A 352 053 22 29	<b>81-1674</b>
	EX [6]	15,04 x 10 x 67,0	G1			A 366 053 07 29	<b>81-1676</b>
					A 352 053 37 30		
					A 366 053 02 30		
	IN [1]	43,87 x 34,5 x 7,4	G1			A 366 053 35 31	<b>92-16155</b>
	EX [2]	38,07 x 30 x 7,9	G1 45°			A 366 053 20 32	<b>92-16154</b>
	EX [2]	38,07 x 30 x 8,5	G1 45°			A 366 053 16 32	<b>92-16109</b>
	EX [1]	38,38 x 30 x 8,5	G1 45°			A 352 053 16 32	<b>92-16131</b>
					A 352 053 21 32		
		739 mm				A 366 050 04 01	<b>20 1003 36601</b>
						A 366 050 06 01	
						A 366 051 11 01	
	[12]	M 28 x 60				A 352 054 05 01	<b>20 1003 35260</b>
	I [1]					A 352 050 10 33	<b>20 1003 36602 (1)</b>
	(1) IN					A 366 050 04 33	

## 197 97,5

<b>OM 356 Euro 1</b>	<b>999</b>	12.1988 → 12.1998	D (LA)	6	5958 cm <sup>3</sup>	2V	177 kW	(240 PS)	16,5:1	133,00 mm
<b>OM 357 Euro 2</b>	<b>912 - 913, 924, 945 - 946</b>	04.1992 →	D (LA)	6	5958 cm <sup>3</sup>	2V	100-177 kW	(136-241 PS)		133,00 mm
<b>OM 377 Euro 0</b>	<b>944</b>	06.1973 →	D (A)	6	5958 cm <sup>3</sup>	2V	125 kW	(170 PS)	16,5:1	133,00 mm

92 525 7..., 94 333 6..

	IN [2]	42,0 x 9 x 140,5	A/S - Cr -	- 20° - -	5 - III	A 366 050 12 26	<b>261100</b>
	IN [2]	42,0 x 9 x 140,5	A/S - Cr -	- 30° - -	5 - III	A 366 050 03 26	<b>16130</b>
	IN [2]	43,0 x 9 x 140,5	A/S - Cr -	- 30° - -	5 - III	A 366 050 02 26	<b>16109</b>
	IN [2]	44,0 x 9 x 140,5	A/S - Cr -	- 45° - -	5 - III	A 352 050 00 26	<b>16136</b>
						A 352 050 01 26	
						A 352 053 01 01	
	EX [2]	36,0 x 10 x 140,5	A/S - Cr -	- 45° - -	5 - III	A 366 050 02 27	<b>16122</b>
	EX [2]	36,0 x 10 x 140,6	A/S - Cr -	- 45° - -	5 - III	A 321 053 09 05	<b>16106</b>
						A 366 050 00 27	
						A 366 050 01 27	
					A 366 050 05 27		
					A 366 050 06 27		
					A 376 050 00 27		
					A 376 050 01 27		
	IN [6]	15,04 x 9 x 72,0	G1			A 352 053 22 29	<b>81-1674</b>
	EX [6]	15,04 x 10 x 67,0	G1			A 366 053 07 29	<b>81-1676</b>
					A 352 053 37 30		
					A 366 053 02 30		

Fortsetzung nächste Seite / continued on next page / suite page suivante / continuación página próxima / Продолжение на следующей странице

					Reference	Item No.
IN [1] EX [2] EX [2] EX [1]	43,87 x 34.5 x 7,4 38,07 x 30 x 7,9 38,07 x 30 x 8,5 38,38 x 30 x 8,5	G1 G1 45° G1 45° G1 45°			A 366 053 35 31 A 366 053 20 32 A 366 053 16 32 A 352 053 16 32 A 352 053 21 32	<b>92-16155</b> <b>92-16154</b> <b>92-16109</b> <b>92-16131</b>
	739 mm				A 366 050 04 01 A 366 050 06 01 A 366 051 11 01	<b>20 1003 36601</b>
[12]	M 28 x 60				A 352 054 05 01	<b>20 1003 35260</b>
I [1]  (1) IN					A 352 050 10 33 A 366 050 04 33	<b>20 1003 36602 (1)</b>

## 198 97,5

<b>OM 372 Euro 0</b>	<b>930</b>									
	06.1973 →	D (NA)	6	5958 cm <sup>3</sup>	2V	100 kW	(136 PS)	17,25:1	133,00 mm	
<b>OM 376 Euro 0</b>	<b>910</b>									
		D (NA)	6	5958 cm <sup>3</sup>	2V	69-100 kW	(94-136 PS)	17,25:1	133,00 mm	

93 951 6..

IN [2] IN [2]	43,0 x 9 x 140,5 44,0 x 9 x 140,5	A/S - Cr - A/S - Cr -	- 30° - - 45° -	- -	5 - III 5 - III	A 366 050 02 26 A 352 050 00 26 A 352 050 01 26 A 352 053 01 01	<b>16109</b> <b>16136</b>
EX [2] EX [2]	36,0 x 10 x 140,5 36,0 x 10 x 140,6	A/S - Cr - A/S - Cr -	- 45° - - 45° -	- -	5 - III 5 - III	A 366 050 02 27 A 321 053 09 05 A 366 050 00 27 A 366 050 01 27 A 366 050 05 27 A 366 050 06 27 A 366 050 00 27 A 376 050 01 27	<b>16122</b> <b>16106</b>
IN [6] IN [6]	15,00 x 9 x 78,0 15,04 x 9 x 72,0	G1 G1				A 312 053 02 30 A 352 053 22 29 A 366 053 07 29	<b>81-1609</b> <b>81-1674</b>
EX [6]	15,04 x 10 x 67,0	G1				A 352 053 37 30 A 366 053 02 30	<b>81-1676</b>
IN [1]  IN [1] EX [2] EX [1]	43,87 x 34.5 x 7,8  44,17 x 34.5 x 7,8 38,07 x 30 x 8,5 38,38 x 30 x 8,5	G1 30°  G1 30° G1 45° G1 45°				A 366 053 09 31 A 366 053 12 31 A 366 053 14 31 A 366 053 10 31 A 366 053 16 32 A 366 053 16 32 A 352 053 16 32 A 352 053 21 32	<b>92-16153</b>  <b>92-16116</b> <b>92-16109</b> <b>92-16131</b>
[12]	M 28 x 60					A 352 054 05 01	<b>20 1003 35260</b>

## 199 97,5

<b>OM 382 Euro 0</b>	<b>917, 950</b>									
	01.1977 →	D (A)	6	5958 cm <sup>3</sup>	2V	110-125 kW	(150-170 PS)		133,00 mm	

IN [2] EX [2]	42,0 x 9 x 140,5 36,0 x 10 x 140,6	A/S - Cr - A/S - Cr -	- 20° - - 45° -	- -	5 - III 5 - III	A 366 050 12 26 A 321 053 09 05 A 366 050 00 27 A 366 050 01 27 A 366 050 05 27 A 366 050 06 27 A 376 050 00 27 A 376 050 01 27	<b>261100</b> <b>16106</b>
------------------	---------------------------------------	--------------------------	--------------------	--------	--------------------	--	-------------------------------

Fortsetzung nächste Seite / continued on next page / suite page suivante / continuación página próxima / Продолжение на следующей странице

					Reference	Item No.
IN [6]	15,04 x 9 x 72,0	G1			A 352 053 22 29 A 366 053 07 29	<b>81-1674</b>
EX [6]	15,04 x 10 x 67,0	G1			A 352 053 37 30 A 366 053 02 30	<b>81-1676</b>
IN [1]	43,87 x 34.5 x 7,4	G1			A 366 053 35 31	<b>92-16155</b>
EX [2]	38,07 x 30 x 7,9	G1 45°			A 366 053 20 32	<b>92-16154</b>
[12]	M 28 x 60				A 352 054 05 01	<b>20 1003 35260</b>
I [1]					A 352 050 10 33 A 366 050 04 33	<b>20 1003 36602 (1)</b>
	(1) IN					

## 200 97,5

OM 366 Euro 0

960, 975

05.1982 → 02.1993 D (A) 6 5958 cm<sup>3</sup> 2V 125-129 kW (170-175 PS) 16,5:1 133,00 mm

90 532 6... 93 831 6..

IN [2]	42,0 x 9 x 140,5	A/S - Cr -	- 20° -	- 5 - III	A 366 050 12 26	<b>261100</b>
IN [2]	42,0 x 9 x 140,5	A/S - Cr -	- 30° -	- 5 - III	A 366 050 03 26	<b>16130</b>
IN [2]	43,0 x 9 x 140,5	A/S - Cr -	- 30° -	- 5 - III	A 366 050 02 26	<b>16109</b>
IN [2]	44,0 x 9 x 140,5	A/S - Cr -	- 45° -	- 5 - III	A 352 050 00 26 A 352 050 01 26 A 352 053 01 01	<b>16136</b>
EX [2]	36,0 x 10 x 140,5	A/S - Cr -	- 45° -	- 5 - III	A 366 050 02 27	<b>16122</b>
EX [2]	36,0 x 10 x 140,6	A/S - Cr -	- 45° -	- 5 - III	A 321 053 09 05 A 366 050 00 27 A 366 050 01 27 A 366 050 05 27 A 366 050 06 27 A 376 050 00 27 A 376 050 01 27	<b>16106</b>
IN [6]	15,00 x 9 x 78,0	G1			A 312 053 02 30	<b>81-1609</b>
IN [6]	15,04 x 9 x 72,0	G1			A 352 053 22 29 A 366 053 07 29	<b>81-1674</b>
EX [6]	15,04 x 10 x 67,0	G1			A 352 053 37 30 A 366 053 02 30	<b>81-1676</b>
IN [1]	43,87 x 34.5 x 7,4	G1			A 366 053 35 31	<b>92-16155</b>
IN [1]	44,17 x 34.5 x 7,8	G1 30°			A 366 053 10 31	<b>92-16116</b>
EX [2]	38,07 x 30 x 7,9	G1 45°			A 366 053 20 32	<b>92-16154</b>
EX [2]	38,07 x 30 x 8,5	G1 45°			A 366 053 16 32	<b>92-16109</b>
EX [1]	38,38 x 30 x 8,5	G1 45°			A 352 053 16 32 A 352 053 21 32	<b>92-16131</b>
	739 mm				A 366 050 04 01 A 366 050 06 01 A 366 051 11 01	<b>20 1003 36601</b>
[12]	M 28 x 60				A 352 054 05 01	<b>20 1003 35260</b>
I [1]					A 352 050 10 33 A 366 050 04 33	<b>20 1003 36602 (1)</b>
	(1) IN					

## 201 97,5

OM 384 Euro 0

906

D (A) 4 3972 cm<sup>3</sup> 2V 66-100 kW (90-137 PS) 17,25:1 133,00 mm

93 951 6..

Fortsetzung nächste Seite / continued on next page / suite page suivante / continuación página próxima / Продолжение на следующей странице

					Reference	Item No.		
	IN [2]	42,0 x 9 x 140,5	A/S - Cr -	- 20° - -	5 - III	A 366 050 12 26	<b>261100</b>	
	IN [2]	42,0 x 9 x 140,5	A/S - Cr -	- 30° - -	5 - III	A 366 050 03 26	<b>16130</b>	
	IN [2]	43,0 x 9 x 140,5	A/S - Cr -	- 30° - -	5 - III	A 366 050 02 26	<b>16109</b>	
	IN [2]	44,0 x 9 x 140,5	A/S - Cr -	- 45° - -	5 - III	A 352 050 00 26 A 352 050 01 26 A 352 053 01 01	<b>16136</b>	
	EX [2]	36,0 x 10 x 140,5	A/S - Cr -	- 45° - -	5 - III	A 366 050 02 27	<b>16122</b>	
	EX [2]	36,0 x 10 x 140,6	A/S - Cr -	- 45° - -	5 - III	A 321 053 09 05 A 366 050 00 27 A 366 050 01 27 A 366 050 05 27 A 366 050 06 27 A 376 050 00 27 A 376 050 01 27	<b>16106</b>	
		IN [6]	15,04 x 9 x 72,0	G1			A 352 053 22 29 A 366 053 07 29	<b>81-1674</b>
		EX [6]	15,04 x 10 x 67,0	G1			A 352 053 37 30 A 366 053 02 30	<b>81-1676</b>
	IN [1]	43,87 x 34.5 x 7,4	G1			A 366 053 35 31	<b>92-16155</b>	
	IN [1]	43,87 x 34.5 x 7,8	G1 30°			A 366 053 09 31 A 366 053 12 31 A 366 053 14 31	<b>92-16153</b>	
	IN [1]	44,17 x 34.5 x 7,8	G1 30°			A 366 053 10 31	<b>92-16116</b>	
	EX [2]	38,07 x 30 x 7,9	G1 45°			A 366 053 20 32	<b>92-16154</b>	
	EX [2]	38,07 x 30 x 8,5	G1 45°			A 366 053 16 32	<b>92-16109</b>	
	EX [1]	38,38 x 30 x 8,5	G1 45°			A 352 053 16 32 A 352 053 21 32	<b>92-16131</b>	
						A 364 050 03 01	<b>20 1003 36400</b>	
	[12]	M 28 x 60				A 352 054 05 01	<b>20 1003 35260</b>	
	I [1]					A 352 050 10 33 A 366 050 04 33	<b>20 1003 36602 (1)</b>	
	(1) IN							

## 202 97,5

OM 364 Euro 0

900-040

1984 →

D

4

3972 cm<sup>3</sup> 2V

49 kW

(67 PS) 17,25:1 133,00 mm

93 951 6..

	IN [2]	43,0 x 9 x 140,5	A/S - Cr -	- 30° - -	5 - III	A 366 050 02 26	<b>16109</b>
	IN [2]	44,0 x 9 x 140,5	A/S - Cr -	- 45° - -	5 - III	A 352 050 00 26 A 352 050 01 26 A 352 053 01 01	<b>16136</b>
	EX [2]	36,0 x 10 x 140,5	A/S - Cr -	- 45° - -	5 - III	A 366 050 02 27	<b>16122</b>
	EX [2]	36,0 x 10 x 140,6	A/S - Cr -	- 45° - -	5 - III	A 321 053 09 05 A 366 050 00 27 A 366 050 01 27 A 366 050 05 27 A 366 050 06 27 A 376 050 00 27 A 376 050 01 27	<b>16106</b>
	IN [1]	43,87 x 34.5 x 7,8	G1 30°			A 366 053 09 31 A 366 053 12 31 A 366 053 14 31	<b>92-16153</b>
	IN [1]	44,17 x 34.5 x 7,8	G1 30°			A 366 053 10 31	<b>92-16116</b>
	EX [2]	38,07 x 30 x 8,5	G1 45°			A 366 053 16 32	<b>92-16109</b>
	EX [1]	38,38 x 30 x 8,5	G1 45°			A 352 053 16 32 A 352 053 21 32	<b>92-16131</b>

					Reference	Item No.	
<b>203</b>		<b>97,5</b>					
<b>OM 364</b>	<b>900/-000</b>	<b>D</b>	<b>4</b>	<b>3972 cm<sup>3</sup></b>	<b>2V</b>	<b>133,00 mm</b>	
93 951 6..							
	IN [2] IN [2]	43,0 x 9 x 140,5 44,0 x 9 x 140,5	A/S - Cr - A/S - Cr -	- 30° - - 45° -	5 - III 5 - III	A 366 050 02 26 A 352 050 00 26 A 352 050 01 26 A 352 053 01 01	<b>16109</b> <b>16136</b>
	EX [2] EX [2]	36,0 x 10 x 140,5 36,0 x 10 x 140,6	A/S - Cr - A/S - Cr -	- 45° - - 45° -	5 - III 5 - III	A 366 050 02 27 A 321 053 09 05 A 366 050 00 27 A 366 050 01 27 A 366 050 05 27 A 366 050 06 27 A 376 050 00 27 A 376 050 01 27	<b>16122</b> <b>16106</b>
	IN [1]	43,87 x 34.5 x 7,8	G1 30°			A 366 053 09 31 A 366 053 12 31 A 366 053 14 31	<b>92-16153</b>
	IN [1] EX [2] EX [1]	44,17 x 34.5 x 7,8 38,07 x 30 x 8,5 38,38 x 30 x 8,5	G1 30° G1 45° G1 45°			A 366 053 10 31 A 366 053 16 32 A 352 053 16 32 A 352 053 21 32	<b>92-16116</b> <b>92-16109</b> <b>92-16131</b>
						A 364 050 03 01	<b>20 1003 36400</b>
	[12]	M 28 x 60				A 352 054 05 01	<b>20 1003 35260</b>
	I [1]					A 352 050 10 33 A 366 050 04 33	<b>20 1003 36602 (1)</b>
	(1) IN						
<b>204</b>		<b>97,5</b>					
<b>OM 364 Euro 0</b>	<b>901/-400</b>	<b>D (A)</b>	<b>4</b>	<b>3972 cm<sup>3</sup></b>	<b>2V</b>	<b>133,00 mm</b>	
90 532 6.., 93 831 6..							
	IN [2] IN [2]	43,0 x 9 x 140,5 44,0 x 9 x 140,5	A/S - Cr - A/S - Cr -	- 30° - - 45° -	5 - III 5 - III	A 366 050 02 26 A 352 050 00 26 A 352 050 01 26 A 352 053 01 01	<b>16109</b> <b>16136</b>
	EX [2] EX [2]	36,0 x 10 x 140,5 36,0 x 10 x 140,6	A/S - Cr - A/S - Cr -	- 45° - - 45° -	5 - III 5 - III	A 366 050 02 27 A 321 053 09 05 A 366 050 00 27 A 366 050 01 27 A 366 050 05 27 A 366 050 06 27 A 376 050 00 27 A 376 050 01 27	<b>16122</b> <b>16106</b>
	IN [1]	43,87 x 34.5 x 7,8	G1 30°			A 366 053 09 31 A 366 053 12 31 A 366 053 14 31	<b>92-16153</b>
	IN [1] EX [2] EX [1]	44,17 x 34.5 x 7,8 38,07 x 30 x 8,5 38,38 x 30 x 8,5	G1 30° G1 45° G1 45°			A 366 053 10 31 A 366 053 16 32 A 352 053 16 32 A 352 053 21 32	<b>92-16116</b> <b>92-16109</b> <b>92-16131</b>
						A 364 050 04 01 A 364 050 06 01	<b>20 1003 36401</b>
Fortsetzung nächste Seite / continued on next page / suite page suivante / continuación página próxima / Продолжение на следующей странице							

**M**



					Reference	Item No.
[12]	M 28 x 60				A 352 054 05 01	<b>20 1003 35260</b>
I [1]					A 352 050 10 33 A 366 050 04 33	<b>20 1003 36602</b> (1)
	(1) IN					

## 205 97,5

<b>OM 366 Euro 1</b>	<b>901-404</b>						
	1992 →	D (A)	6	5958 cm <sup>3</sup>	2V		133,00 mm
<b>OM 366 Euro 1</b>	<b>901-504</b>						
		D (LA)	6	5958 cm <sup>3</sup>	2V		133,00 mm
<b>OM 366 Euro 2</b>	<b>901-507</b>						
		D (LA)	6	5958 cm <sup>3</sup>	2V		133,00 mm
<b>OM 366 Euro 0</b>	<b>901-501, 901-540, 901-541, 901/-500</b>						
	1984 →	D (LA)	6	5958 cm <sup>3</sup>	2V	136-177 kW (185-240 PS)	133,00 mm

90 532 6..., 91 598 6..., 92 525 7..., 93 831 6..., 94 333 6..

	IN [2]	42,0 x 9 x 140,5	A/S - Cr -	- 20° -	-	5 - III	A 366 050 12 26	<b>261100</b>	
	IN [2]	42,0 x 9 x 140,5	A/S - Cr -	- 30° -	-	5 - III	A 366 050 03 26	<b>16130</b>	
	IN [2]	43,0 x 9 x 140,5	A/S - Cr -	- 30° -	-	5 - III	A 366 050 02 26	<b>16109</b>	
	IN [2]	44,0 x 9 x 140,5	A/S - Cr -	- 45° -	-	5 - III	A 352 050 00 26 A 352 050 01 26 A 352 053 01 01	<b>16136</b>	
	EX [2]	36,0 x 10 x 140,5	A/S - Cr -	- 45° -	-	5 - III	A 366 050 02 27	<b>16122</b>	
	EX [2]	36,0 x 10 x 140,6	A/S - Cr -	- 45° -	-	5 - III	A 321 053 09 05 A 366 050 00 27 A 366 050 01 27 A 366 050 05 27 A 366 050 06 27 A 376 050 00 27 A 376 050 01 27	<b>16106</b>	
		IN [6]	15,00 x 9 x 78,0	G1				A 312 053 02 30	<b>81-1609</b>
		IN [6]	15,04 x 9 x 72,0	G1				A 352 053 22 29 A 366 053 07 29	<b>81-1674</b>
		EX [6]	15,04 x 10 x 67,0	G1				A 352 053 37 30 A 366 053 02 30	<b>81-1676</b>
		IN [1]	43,87 x 34.5 x 7,4	G1				A 366 053 35 31	<b>92-16155</b>
		IN [1]	43,87 x 34.5 x 7,8	G1 30°				A 366 053 09 31 A 366 053 12 31 A 366 053 14 31	<b>92-16153</b>
		IN [1]	44,17 x 34.5 x 7,8	G1 30°				A 366 053 10 31	<b>92-16116</b>
	EX [2]	38,07 x 30 x 8,5	G1 45°				A 366 053 16 32	<b>92-16109</b>	
	EX [1]	38,38 x 30 x 8,5	G1 45°				A 352 053 16 32 A 352 053 21 32	<b>92-16131</b>	

## 206 97,5

<b>OM 306 Euro 0</b>	<b>900-016 (ZA), 900-017 (ZA), 900-018 (ZA)</b>						
		D (A)	6	5958 cm <sup>3</sup>	2V	92 kW (125 PS)	16,5:1 133,00 mm

90 532 6..., 93 831 6..

Fortsetzung nächste Seite / continued on next page / suite page suivante / continuación página próxima / Продолжение на следующей странице

					Reference	Item No.	
	IN [2]	42,0 x 9 x 140,5	A/S - Cr -	- 20° - -	5 - III	A 366 050 12 26	<b>261100</b>
	IN [2]	42,0 x 9 x 140,5	A/S - Cr -	- 30° - -	5 - III	A 366 050 03 26	<b>16130</b>
	IN [2]	43,0 x 9 x 140,5	A/S - Cr -	- 30° - -	5 - III	A 366 050 02 26	<b>16109</b>
	IN [2]	44,0 x 9 x 140,5	A/S - Cr -	- 45° - -	5 - III	A 352 050 00 26	<b>16136</b>
						A 352 050 01 26	
						A 352 053 01 01	
	EX [2]	36,0 x 10 x 140,5	A/S - Cr -	- 45° - -	5 - III	A 366 050 02 27	<b>16122</b>
	EX [2]	36,0 x 10 x 140,6	A/S - Cr -	- 45° - -	5 - III	A 321 053 09 05	<b>16106</b>
						A 366 050 00 27	
						A 366 050 01 27	
					A 366 050 05 27		
					A 366 050 06 27		
					A 376 050 00 27		
					A 376 050 01 27		
	IN [6]	15,00 x 9 x 78,0	G1			A 312 053 02 30	<b>81-1609</b>
	IN [6]	15,04 x 9 x 72,0	G1			A 352 053 22 29	<b>81-1674</b>
	EX [6]	15,04 x 10 x 67,0	G1			A 366 053 07 29	<b>81-1676</b>
					A 352 053 37 30		
					A 366 053 02 30		
	IN [1]	43,87 x 34,5 x 7,4	G1			A 366 053 35 31	<b>92-16155</b>
	IN [1]	43,87 x 34,5 x 7,8	G1 30°			A 366 053 09 31	<b>92-16153</b>
						A 366 053 12 31	
						A 366 053 14 31	
	IN [1]	44,17 x 34,5 x 7,8	G1 30°			A 366 053 10 31	<b>92-16116</b>
	EX [2]	38,07 x 30 x 7,9	G1 45°			A 366 053 20 32	<b>92-16154</b>
	EX [2]	38,07 x 30 x 8,5	G1 45°			A 366 053 16 32	<b>92-16109</b>
EX [1]	38,38 x 30 x 8,5	G1 45°			A 352 053 16 32	<b>92-16131</b>	
					A 352 053 21 32		
	739 mm				A 366 050 03 01	<b>20 1003 36600</b>	
	I [1]					A 352 050 10 33	<b>20 1003 36602 (1)</b>
	(1) IN					A 366 050 04 33	

## 207 97,5

<b>OM 374 Euro 0</b>	<b>953</b>								
	06.1985 →	D	4	3972 cm <sup>3</sup>	2V	80 kW	(110 PS)	16,5:1	133,00 mm
<b>OM 374 Euro 0</b>	<b>980, 984 - 985</b>								
	01.1984 → 12.1998	D (A)	4	3972 cm <sup>3</sup>	2V	100-104 kW	(136-140 PS)	16,5:1	133,00 mm

	IN [2]	42,0 x 9 x 140,5	A/S - Cr -	- 20° - -	5 - III	A 366 050 12 26	<b>261100</b>
	IN [2]	42,0 x 9 x 140,5	A/S - Cr -	- 30° - -	5 - III	A 366 050 03 26	<b>16130</b>
	IN [2]	43,0 x 9 x 140,5	A/S - Cr -	- 30° - -	5 - III	A 366 050 02 26	<b>16109</b>
	IN [2]	44,0 x 9 x 140,5	A/S - Cr -	- 45° - -	5 - III	A 352 050 00 26	<b>16136</b>
						A 352 050 01 26	
						A 352 053 01 01	
	EX [2]	36,0 x 10 x 140,5	A/S - Cr -	- 45° - -	5 - III	A 366 050 02 27	<b>16122</b>
	EX [2]	36,0 x 10 x 140,5	S - Cr -	- 45° - VS -	5 - III	A 352 053 15 05	<b>1604</b>
	EX [2]	36,0 x 10 x 140,6	A/S - Cr -	- 45° - -	5 - III	A 321 053 09 05	<b>16106</b>
						A 366 050 00 27	
					A 366 050 01 27		
					A 366 050 05 27		
					A 366 050 06 27		
					A 376 050 00 27		
					A 376 050 01 27		
	IN [6]	15,00 x 9 x 78,0	G1			A 312 053 02 30	<b>81-1609</b>
	IN [6]	15,04 x 9 x 72,0	G1			A 352 053 22 29	<b>81-1674</b>
	EX [6]	15,04 x 10 x 67,0	G1			A 366 053 07 29	<b>81-1676</b>
					A 352 053 37 30		
					A 366 053 02 30		

Fortsetzung nächste Seite / continued on next page / suite page suivante / continuación página próxima / Продолжение на следующей странице

					Reference	Item No.
IN [1] EX [2] EX [2] EX [1]	43,87 x 34,5 x 7,4 38,07 x 30 x 7,9 38,07 x 30 x 8,5 38,38 x 30 x 8,5	G1 G1 45° G1 45° G1 45°			A 366 053 35 31 A 366 053 20 32 A 366 053 16 32 A 352 053 16 32 A 352 053 21 32	<b>92-16155</b> <b>92-16154</b> <b>92-16109</b> <b>92-16131</b>
					A 364 050 04 01 A 364 050 06 01	<b>20 1003 36401</b>
[12]	M 28 x 60				A 352 054 05 01	<b>20 1003 35260</b>
I [1]  (1) IN					A 352 050 10 33 A 366 050 04 33	<b>20 1003 36602 (1)</b>

## 208 97,5

<b>OM 356 Euro 1</b>	<b>901 - 916</b> 02.1987 →	D (NA)	6	5958 cm <sup>3</sup>	2V	75-100 kW	(102-136 PS)	133,00 mm
<b>OM 366 Euro 1</b>	<b>915, 938</b> 01.1988 →	D (NA)	6	5958 cm <sup>3</sup>	2V	75-102 kW	(102-139 PS)	133,00 mm
<b>OM 366 Euro 0</b>	<b>900/-000</b>	D	6	5958 cm <sup>3</sup>	2V			133,00 mm
<b>OM 366 Euro 0</b>	<b>905</b> 03.1984 → 02.1993	D (LA)	6	5958 cm <sup>3</sup>	2V	100 kW	(136 PS) 17,25:1	133,00 mm
<b>OM 366 Euro 0</b>	<b>906 - 910, 912 - 914, 917 - 919, 930 - 933, 935 - 937, 939 - 940</b> 03.1984 →	D (NA)	6	5958 cm <sup>3</sup>	2V	74-102 kW	(100-139 PS)	133,00 mm
<b>OM 382 Euro 0</b>	<b>912, 916</b>	D (NA)	6	5958 cm <sup>3</sup>	2V	96-100 kW	(130-136 PS)	133,00 mm
<b>OM 386 Euro 0</b>	<b>906</b>	D (A)	6	5958 cm <sup>3</sup>	2V	100 kW	(136 PS) 16,5:1	133,00 mm

91 550 6..., 91 551 6..., 93 951 6...

IN [2] IN [2] IN [2] IN [2]	42,0 x 9 x 140,5 42,0 x 9 x 140,5 43,0 x 9 x 140,5 44,0 x 9 x 140,5	A/S - Cr - A/S - Cr - A/S - Cr - A/S - Cr -	- 20° - - - 30° - - - 30° - - - 45° - -	5 - III 5 - III 5 - III 5 - III	A 366 050 12 26 A 366 050 03 26 A 366 050 02 26 A 352 050 00 26 A 352 050 01 26 A 352 053 01 01	<b>261100</b> <b>16130</b> <b>16109</b> <b>16136</b>
EX [2] EX [2]	36,0 x 10 x 140,5 36,0 x 10 x 140,6	A/S - Cr - A/S - Cr -	- 45° - - - 45° - -	5 - III 5 - III	A 366 050 02 27 A 321 053 09 05 A 366 050 00 27 A 366 050 01 27 A 366 050 05 27 A 366 050 06 27 A 376 050 00 27 A 376 050 01 27	<b>16122</b> <b>16106</b>
IN [6] IN [6]  EX [6]	15,00 x 9 x 78,0 15,04 x 9 x 72,0  15,04 x 10 x 67,0	G1 G1  G1			A 312 053 02 30 A 352 053 22 29 A 366 053 07 29 A 352 053 37 30 A 366 053 02 30	<b>81-1609</b> <b>81-1674</b>  <b>81-1676</b>
IN [1] IN [1]  IN [1] EX [2] EX [2] EX [1]	43,87 x 34,5 x 7,4 43,87 x 34,5 x 7,8  44,17 x 34,5 x 7,8 38,07 x 30 x 7,9 38,07 x 30 x 8,5 38,38 x 30 x 8,5	G1 G1 30°  G1 30° G1 45° G1 45° G1 45°			A 366 053 35 31 A 366 053 09 31 A 366 053 12 31 A 366 053 14 31 A 366 053 10 31 A 366 053 20 32 A 366 053 16 32 A 352 053 16 32 A 352 053 21 32	<b>92-16155</b> <b>92-16153</b>  <b>92-16116</b> <b>92-16154</b> <b>92-16109</b> <b>92-16131</b>
	739 mm				A 366 050 03 01	<b>20 1003 36600</b>

Fortsetzung nächste Seite / continued on next page / suite page suivante / continuación página próxima / Продолжение на следующей странице

					Reference	Item No.
[12]	M 28 x 60				A 352 054 05 01	<b>20 1003 35260</b>
I [1]					A 352 050 10 33 A 366 050 04 33	<b>20 1003 36602</b> (1)
	(1) IN					

## 209 97,5

<b>OM 364</b>	<b>913</b>	07.1987 → 12.1992	D (NA)	4	3972 cm <sup>3</sup>	2V	66 kW	(90 PS)	17,3	133,00 mm
<b>OM 364 Euro 0</b>	<b>906 - 907, 911 - 912</b>	03.1984 → 12.2005	D (NA)	4	3972 cm <sup>3</sup>	2V	63-66 kW	(86-90 PS)		133,00 mm

93 951 6..

	IN [2]	42,0 x 9 x 140,5	A/S - Cr -	- 20° -	-	5 - III	A 366 050 12 26	<b>261100</b>
	IN [2]	42,0 x 9 x 140,5	A/S - Cr -	- 30° -	-	5 - III	A 366 050 03 26	<b>16130</b>
	IN [2]	43,0 x 9 x 140,5	A/S - Cr -	- 30° -	-	5 - III	A 366 050 02 26	<b>16109</b>
	IN [2]	44,0 x 9 x 140,5	A/S - Cr -	- 45° -	-	5 - III	A 352 050 00 26 A 352 050 01 26 A 352 053 01 01	<b>16136</b>
	EX [2]	36,0 x 10 x 140,5	A/S - Cr -	- 45° -	-	5 - III	A 366 050 02 27	<b>16122</b>
	EX [2]	36,0 x 10 x 140,6	A/S - Cr -	- 45° -	-	5 - III	A 321 053 09 05 A 366 050 00 27 A 366 050 01 27 A 366 050 05 27 A 366 050 06 27 A 376 050 00 27 A 376 050 01 27	<b>16106</b>
	IN [6]	15,00 x 9 x 78,0	G1				A 312 053 02 30	<b>81-1609</b>
	IN [6]	15,04 x 9 x 72,0	G1				A 352 053 22 29 A 366 053 07 29	<b>81-1674</b>
	EX [6]	15,04 x 10 x 67,0	G1				A 352 053 37 30 A 366 053 02 30	<b>81-1676</b>
	IN [1]	43,87 x 34.5 x 7,4	G1				A 366 053 35 31	<b>92-16155</b>
	IN [1]	43,87 x 34.5 x 7,8	G1 30°				A 366 053 09 31 A 366 053 12 31 A 366 053 14 31	<b>92-16153</b>
	IN [1]	44,17 x 34.5 x 7,8	G1 30°				A 366 053 10 31	<b>92-16116</b>
	EX [2]	38,07 x 30 x 7,9	G1 45°				A 366 053 20 32	<b>92-16154</b>
	EX [2]	38,07 x 30 x 8,5	G1 45°				A 366 053 16 32	<b>92-16109</b>
	EX [1]	38,38 x 30 x 8,5	G1 45°				A 352 053 16 32 A 352 053 21 32	<b>92-16131</b>
							A 364 050 03 01	<b>20 1003 36400</b>
[12]	M 28 x 60						A 352 054 05 01	<b>20 1003 35260</b>
I [1]							A 352 050 10 33 A 366 050 04 33	<b>20 1003 36602</b> (1)
	(1) IN							

## 210 97,5

<b>OM 364 Euro 0</b>	<b>981, 984</b>	11.1987 → 12.1994	D (LA)	4	3972 cm <sup>3</sup>	2V	100 kW	(136 PS)	17:1	133,00 mm
<b>OM 364 Euro 0</b>	<b>950, 952, 954</b>	03.1984 → 12.1994	D (A)	4	3972 cm <sup>3</sup>	2V	85 kW	(115 PS)	16,5	133,00 mm

90 532 6.., 93 831 6..

Fortsetzung nächste Seite / continued on next page / suite page suivante / continuación página próxima / Продолжение на следующей странице

					Reference	Item No.	
	IN [2]	42,0 x 9 x 140,5	A/S - Cr -	- 20° - -	5 - III	A 366 050 12 26	<b>261100</b>
	IN [2]	42,0 x 9 x 140,5	A/S - Cr -	- 30° - -	5 - III	A 366 050 03 26	<b>16130</b>
	IN [2]	43,0 x 9 x 140,5	A/S - Cr -	- 30° - -	5 - III	A 366 050 02 26	<b>16109</b>
	IN [2]	44,0 x 9 x 140,5	A/S - Cr -	- 45° - -	5 - III	A 352 050 00 26 A 352 050 01 26 A 352 053 01 01	<b>16136</b>
	EX [2]	36,0 x 10 x 140,5	A/S - Cr -	- 45° - -	5 - III	A 366 050 02 27	<b>16122</b>
	EX [2]	36,0 x 10 x 140,6	A/S - Cr -	- 45° - -	5 - III	A 321 053 09 05 A 366 050 00 27 A 366 050 01 27 A 366 050 05 27 A 366 050 06 27 A 376 050 00 27 A 376 050 01 27	<b>16106</b>
	IN [6]	15,00 x 9 x 78,0	G1			A 312 053 02 30	<b>81-1609</b>
	IN [6]	15,04 x 9 x 72,0	G1			A 352 053 22 29 A 366 053 07 29	<b>81-1674</b>
	EX [6]	15,04 x 10 x 67,0	G1			A 352 053 37 30 A 366 053 02 30	<b>81-1676</b>
	IN [1]	43,87 x 34,5 x 7,4	G1			A 366 053 35 31	<b>92-16155</b>
	EX [2]	38,07 x 30 x 7,9	G1 45°			A 366 053 20 32	<b>92-16154</b>
	EX [2]	38,07 x 30 x 8,5	G1 45°			A 366 053 16 32	<b>92-16109</b>
	EX [1]	38,38 x 30 x 8,5	G1 45°			A 352 053 16 32 A 352 053 21 32	<b>92-16131</b>
					A 364 050 04 01 A 364 050 06 01	<b>20 1003 36401</b>	
	[12]	M 28 x 60			A 352 054 05 01	<b>20 1003 35260</b>	
	I [1]				A 352 050 10 33 A 366 050 04 33	<b>20 1003 36602 (1)</b>	
	(1) IN						

**211**
**97,5**
**OM 304**
**900-401, 900-410**

06.1985 →

 D (A) 4 3972 cm<sup>3</sup> 2V

85 kW

(115 PS) 16,5:1 133,00 mm

90 532 6.., 93 831 6..

	IN [2]	42,0 x 9 x 140,5	A/S - Cr -	- 20° - -	5 - III	A 366 050 12 26	<b>261100</b>
	IN [2]	43,0 x 9 x 140,5	A/S - Cr -	- 30° - -	5 - III	A 366 050 02 26	<b>16109</b>
	EX [2]	36,0 x 10 x 140,6	A/S - Cr -	- 45° - -	5 - III	A 321 053 09 05 A 366 050 00 27 A 366 050 01 27 A 366 050 05 27 A 366 050 06 27 A 376 050 00 27 A 376 050 01 27	<b>16106</b>
	IN [6]	15,04 x 9 x 72,0	G1			A 352 053 22 29 A 366 053 07 29	<b>81-1674</b>
	EX [6]	15,04 x 10 x 67,0	G1			A 352 053 37 30 A 366 053 02 30	<b>81-1676</b>
	IN [1]	43,87 x 34,5 x 7,4	G1			A 366 053 35 31	<b>92-16155</b>
	EX [2]	38,07 x 30 x 7,9	G1 45°			A 366 053 20 32	<b>92-16154</b>
	EX [2]	38,07 x 30 x 8,5	G1 45°			A 366 053 16 32	<b>92-16109</b>
	EX [1]	38,38 x 30 x 8,5	G1 45°			A 352 053 16 32 A 352 053 21 32	<b>92-16131</b>
	I [1]				A 352 050 10 33 A 366 050 04 33	<b>20 1003 36602 (1)</b>	
	(1) IN						



					Reference	Item No.
<b>212</b>		<b>97,5</b>				
<b>OM 354 Euro 2</b>	<b>900 - 903, 920, 923 - 926</b>					
	11.1987 →	D (LA)	4	3972 cm <sup>3</sup>	2V 77-103 kW (105-140 PS)	133,00 mm
<b>OM 364 Euro 1</b>	<b>986 - 987</b>					
	06.1985 →	D (LA)	4	3972 cm <sup>3</sup>	2V 100 kW (136 PS) 18:1	133,00 mm
<b>OM 364 Euro 1</b>	<b>957 - 958</b>					
	02.1992 →	D (A)	4	3972 cm <sup>3</sup>	2V 77 kW (105 PS) 16,5	133,00 mm
<b>OM 380 Euro 0</b>	<b>943</b>					
	12.1993 →	D (A)	4	3972 cm <sup>3</sup>	2V 79 kW (107 PS) 16,5:1	133,00 mm
<b>OM 384 Euro 1</b>	<b>908</b>					
	12.1993 →	D (A)	4	3972 cm <sup>3</sup>	2V 79 kW (107 PS) 16,5:1	133,00 mm
90 532 6..., 91 598 6..., 92 525 7..., 93 831 6..., 94 333 6..						
	IN [2]	42,0 x 9 x 140,5	A/S - Cr -	- 20° -	- 5 - III	A 366 050 12 26 <b>261100</b>
	IN [2]	42,0 x 9 x 140,5	A/S - Cr -	- 30° -	- 5 - III	A 366 050 03 26 <b>16130</b>
	IN [2]	43,0 x 9 x 140,5	A/S - Cr -	- 30° -	- 5 - III	A 366 050 02 26 <b>16109</b>
	IN [2]	44,0 x 9 x 140,5	A/S - Cr -	- 45° -	- 5 - III	A 352 050 00 26 <b>16136</b>
						A 352 050 01 26
						A 352 053 01 01
	EX [2]	36,0 x 10 x 140,5	A/S - Cr -	- 45° -	- 5 - III	A 366 050 02 27 <b>16122</b>
	EX [2]	36,0 x 10 x 140,6	A/S - Cr -	- 45° -	- 5 - III	A 321 053 09 05 <b>16106</b>
						A 366 050 00 27
						A 366 050 01 27
						A 366 050 05 27
						A 366 050 06 27
						A 376 050 00 27
						A 376 050 01 27
	IN [6]	15,04 x 9 x 72,0	G1			A 352 053 22 29 <b>81-1674</b>
	EX [6]	15,04 x 10 x 67,0	G1			A 366 053 07 29
						A 352 053 37 30 <b>81-1676</b>
						A 366 053 02 30
	IN [1]	43,87 x 34.5 x 7,4	G1			A 366 053 35 31 <b>92-16155</b>
	EX [2]	38,07 x 30 x 7,9	G1 45°			A 366 053 20 32 <b>92-16154</b>
	EX [2]	38,07 x 30 x 8,5	G1 45°			A 366 053 16 32 <b>92-16109</b>
	EX [1]	38,38 x 30 x 8,5	G1 45°			A 352 053 16 32 <b>92-16131</b>
						A 352 053 21 32
						A 364 050 04 01 <b>20 1003 36401</b>
						A 364 050 06 01
	[12]	M 28 x 60				A 352 054 05 01 <b>20 1003 35260</b>
	I [1]					A 352 050 10 33 <b>20 1003 36602 (1)</b>
						A 366 050 04 33
	(1) IN					

<b>213</b>		<b>97,5</b>				
<b>OM 354 Euro 2</b>	<b>921 - 922</b>					
	03.1994 → 12.1998	D (LA)	4	3972 cm <sup>3</sup>	2V 103 kW (140 PS) 18:1	133,00 mm
<b>OM 364 Euro 1</b>	<b>955 - 956, 982, 985, 989</b>					
	06.1985 →	D (LA)	4	3972 cm <sup>3</sup>	2V 75-103 kW (102-140 PS)	133,00 mm
<b>OM 364 Euro 1</b>	<b>959</b>					
	04.1991 →	D (A)	4	3972 cm <sup>3</sup>	2V 77 kW (105 PS) 18:1	133,00 mm
90 532 6..., 91 598 6..., 92 525 7..., 93 831 6..., 94 333 6..						

Fortsetzung nächste Seite / continued on next page / suite page suivante / continuación página próxima / Продолжение на следующей странице

					Reference	Item No.		
	IN [2]	42,0 x 9 x 140,5	A/S - Cr -	- 20° - -	5 - III	A 366 050 12 26	<b>261100</b>	
	IN [2]	42,0 x 9 x 140,5	A/S - Cr -	- 30° - -	5 - III	A 366 050 03 26	<b>16130</b>	
	IN [2]	43,0 x 9 x 140,5	A/S - Cr -	- 30° - -	5 - III	A 366 050 02 26	<b>16109</b>	
	IN [2]	44,0 x 9 x 140,5	A/S - Cr -	- 45° - -	5 - III	A 352 050 00 26 A 352 050 01 26 A 352 053 01 01	<b>16136</b>	
	EX [2]	36,0 x 10 x 140,5	A/S - Cr -	- 45° - -	5 - III	A 366 050 02 27	<b>16122</b>	
	EX [2]	36,0 x 10 x 140,6	A/S - Cr -	- 45° - -	5 - III	A 321 053 09 05 A 366 050 00 27 A 366 050 01 27 A 366 050 05 27 A 366 050 06 27 A 376 050 00 27 A 376 050 01 27	<b>16106</b>	
		IN [1]	43,87 x 34,5 x 7,4	G1			A 366 053 35 31	<b>92-16155</b>
		EX [2]	38,07 x 30 x 7,9	G1 45°			A 366 053 20 32	<b>92-16154</b>
EX [2]		38,07 x 30 x 8,5	G1 45°			A 366 053 16 32	<b>92-16109</b>	
EX [1]		38,38 x 30 x 8,5	G1 45°			A 352 053 16 32 A 352 053 21 32	<b>92-16131</b>	
						A 364 050 04 01 A 364 050 06 01	<b>20 1003 36401</b>	
	[12]	M 28 x 60				A 352 054 05 01	<b>20 1003 35260</b>	
	I [1]					A 352 050 10 33 A 366 050 04 33	<b>20 1003 36602 (1)</b>	
	(1) IN							
<b>214</b>		<b>97,5</b>						
<b>OM 370 Euro 0</b>	<b>950 - 951</b>		D (A)	4	3972 cm <sup>3</sup> 2V	85 kW (116 PS) 16,5:1	133,00 mm	
<b>OM 374 Euro 0</b>	<b>950 - 952</b>		D	4	3972 cm <sup>3</sup> 2V	85 kW (115 PS) 16,5:1	133,00 mm	
	06.1985→							
90 532 6.., 93 831 6..								
	IN [2]	42,0 x 9 x 140,5	A/S - Cr -	- 30° - -	5 - III	A 366 050 03 26	<b>16130</b>	
	IN [2]	43,0 x 9 x 140,5	A/S - Cr -	- 30° - -	5 - III	A 366 050 02 26	<b>16109</b>	
	IN [2]	44,0 x 9 x 140,5	A/S - Cr -	- 45° - -	5 - III	A 352 050 00 26 A 352 050 01 26 A 352 053 01 01	<b>16136</b>	
	EX [2]	36,0 x 10 x 140,5	A/S - Cr -	- 45° - -	5 - III	A 366 050 02 27	<b>16122</b>	
	EX [2]	36,0 x 10 x 140,5	S - Cr -	- 45° - VS -	5 - III	A 352 053 15 05	<b>1604</b>	
	EX [2]	36,0 x 10 x 140,6	A/S - Cr -	- 45° - -	5 - III	A 321 053 09 05 A 366 050 00 27 A 366 050 01 27 A 366 050 05 27 A 366 050 06 27 A 376 050 00 27 A 376 050 01 27	<b>16106</b>	
		IN [6]	15,00 x 9 x 78,0	G1			A 312 053 02 30	<b>81-1609</b>
		IN [6]	15,04 x 9 x 72,0	G1			A 352 053 22 29 A 366 053 07 29	<b>81-1674</b>
	EX [6]	15,04 x 10 x 67,0	G1			A 352 053 37 30 A 366 053 02 30	<b>81-1676</b>	
	EX [2]	38,07 x 30 x 8,5	G1 45°			A 366 053 16 32	<b>92-16109</b>	
	EX [1]	38,38 x 30 x 8,5	G1 45°			A 352 053 16 32 A 352 053 21 32	<b>92-16131</b>	
						A 364 050 04 01 A 364 050 06 01	<b>20 1003 36401</b>	

Fortsetzung nächste Seite / continued on next page / suite page suivante / continuación página próxima / Продолжение на следующей странице

					Reference	Item No.
[12]	M 28 x 60				A 352 054 05 01	20 1003 35260
I [1]					A 352 050 10 33 A 366 050 04 33	20 1003 36602 (1)
	(1) IN					

## 215 97,5

<b>OM 370 Euro 0</b>	<b>952</b>								
	06.1985 →	D (A)	4	3972 cm <sup>3</sup>	2V	80 kW	(109 PS)	16,5:1	133,00 mm
<b>OM 374 Euro 0</b>	<b>986, 988</b>								
	04.1995 →	D (A)	4	3972 cm <sup>3</sup>	2V	77-81 kW	(105-110 PS)	16,5:1	133,00 mm

93 951 6..

	IN [2]	42,0 x 9 x 140,5	A/S - Cr -	- 20° -	-	5 - III	A 366 050 12 26	<b>261100</b>
	IN [2]	42,0 x 9 x 140,5	A/S - Cr -	- 30° -	-	5 - III	A 366 050 03 26	<b>16130</b>
	IN [2]	43,0 x 9 x 140,5	A/S - Cr -	- 30° -	-	5 - III	A 366 050 02 26	<b>16109</b>
	IN [2]	44,0 x 9 x 140,5	A/S - Cr -	- 45° -	-	5 - III	A 352 050 00 26 A 352 050 01 26 A 352 053 01 01	<b>16136</b>
	EX [2]	36,0 x 10 x 140,5	A/S - Cr -	- 45° -	-	5 - III	A 366 050 02 27	<b>16122</b>
	EX [2]	36,0 x 10 x 140,6	A/S - Cr -	- 45° -	-	5 - III	A 321 053 09 05 A 366 050 00 27 A 366 050 01 27 A 366 050 05 27 A 366 050 06 27 A 376 050 00 27 A 376 050 01 27	<b>16106</b>
	IN [6]	15,00 x 9 x 78,0	G1				A 312 053 02 30	<b>81-1609</b>
	IN [6]	15,04 x 9 x 72,0	G1				A 352 053 22 29 A 366 053 07 29	<b>81-1674</b>
	EX [6]	15,04 x 10 x 67,0	G1				A 352 053 37 30 A 366 053 02 30	<b>81-1676</b>
	IN [1]	43,87 x 34.5 x 7,4	G1				A 366 053 35 31	<b>92-16155</b>
	EX [2]	38,07 x 30 x 7,9	G1 45°				A 366 053 20 32	<b>92-16154</b>
							A 364 050 04 01 A 364 050 06 01	<b>20 1003 36401</b>
[12]	M 28 x 60						A 352 054 05 01	<b>20 1003 35260</b>
I [1]							A 352 050 10 33 A 366 050 04 33	<b>20 1003 36602 (1)</b>
	(1) IN							

## 216 97,5

<b>OM 380 Euro 0</b>	<b>940, 942</b>								
	06.1985 →	D (A)	4	3972 cm <sup>3</sup>	2V	85 kW	(116 PS)	16,5:1	133,00 mm

90 532 6.., 93 831 6..

Fortsetzung nächste Seite / continued on next page / suite page suivante / continuación página próxima / Продолжение на следующей странице

M

					Reference	Item No.	
	IN [2]	42,0 x 9 x 140,5	A/S - Cr -	- 20° - -	5 - III	A 366 050 12 26	<b>261100</b>
	IN [2]	42,0 x 9 x 140,5	A/S - Cr -	- 30° - -	5 - III	A 366 050 03 26	<b>16130</b>
	IN [2]	43,0 x 9 x 140,5	A/S - Cr -	- 30° - -	5 - III	A 366 050 02 26	<b>16109</b>
	IN [2]	44,0 x 9 x 140,5	A/S - Cr -	- 45° - -	5 - III	A 352 050 00 26 A 352 050 01 26 A 352 053 01 01	<b>16136</b>
	EX [2]	36,0 x 10 x 140,5	A/S - Cr -	- 45° - -	5 - III	A 366 050 02 27	<b>16122</b>
	EX [2]	36,0 x 10 x 140,5	S - Cr -	- 45° - VS -	5 - III	A 352 053 15 05	<b>1604</b>
	EX [2]	36,0 x 10 x 140,6	A/S - Cr -	- 45° - -	5 - III	A 321 053 09 05 A 366 050 00 27 A 366 050 01 27 A 366 050 05 27 A 366 050 06 27 A 376 050 00 27 A 376 050 01 27	<b>16106</b>
	IN [1]	43,87 x 34.5 x 7,4	G1			A 366 053 35 31	<b>92-16155</b>
	EX [2]	38,07 x 30 x 7,9	G1 45°			A 366 053 20 32	<b>92-16154</b>
	EX [2]	38,07 x 30 x 8,5	G1 45°			A 366 053 16 32	<b>92-16109</b>
	EX [1]	38,38 x 30 x 8,5	G1 45°			A 352 053 16 32 A 352 053 21 32	<b>92-16131</b>
					A 364 050 04 01 A 364 050 06 01	<b>20 1003 36401</b>	
	[12]	M 28 x 60			A 352 054 05 01	<b>20 1003 35260</b>	
	I [1]				A 352 050 10 33 A 366 050 04 33	<b>20 1003 36602 (1)</b>	
	(1) IN						

## 217 97,5

OM 384 Euro 0

907

06.1985 →

D (A) 4 3972 cm<sup>3</sup> 2V

85 kW

(116 PS) 16,5:1 133,00 mm

90 532 6.., 93 831 6..

	IN [2]	42,0 x 9 x 140,5	A/S - Cr -	- 20° - -	5 - III	A 366 050 12 26	<b>261100</b>
	IN [2]	42,0 x 9 x 140,5	A/S - Cr -	- 30° - -	5 - III	A 366 050 03 26	<b>16130</b>
	IN [2]	43,0 x 9 x 140,5	A/S - Cr -	- 30° - -	5 - III	A 366 050 02 26	<b>16109</b>
	IN [2]	44,0 x 9 x 140,5	A/S - Cr -	- 45° - -	5 - III	A 352 050 00 26 A 352 050 01 26 A 352 053 01 01	<b>16136</b>
	EX [2]	36,0 x 10 x 140,5	A/S - Cr -	- 45° - -	5 - III	A 366 050 02 27	<b>16122</b>
	EX [2]	36,0 x 10 x 140,5	S - Cr -	- 45° - VS -	5 - III	A 352 053 15 05	<b>1604</b>
	EX [2]	36,0 x 10 x 140,6	A/S - Cr -	- 45° - -	5 - III	A 321 053 09 05 A 366 050 00 27 A 366 050 01 27 A 366 050 05 27 A 366 050 06 27 A 376 050 00 27 A 376 050 01 27	<b>16106</b>
	IN [6]	15,04 x 9 x 72,0	G1			A 352 053 22 29 A 366 053 07 29	<b>81-1674</b>
	EX [6]	15,04 x 10 x 67,0	G1			A 352 053 37 30 A 366 053 02 30	<b>81-1676</b>
	IN [1]	43,87 x 34.5 x 7,4	G1			A 366 053 35 31	<b>92-16155</b>
	EX [2]	38,07 x 30 x 7,9	G1 45°			A 366 053 20 32	<b>92-16154</b>
	EX [2]	38,07 x 30 x 8,5	G1 45°			A 366 053 16 32	<b>92-16109</b>
	EX [1]	38,38 x 30 x 8,5	G1 45°			A 352 053 16 32 A 352 053 21 32	<b>92-16131</b>
					A 364 050 04 01 A 364 050 06 01	<b>20 1003 36401</b>	

Fortsetzung nächste Seite / continued on next page / suite page suivante / continuación página próxima / Продолжение на следующей странице

					Reference	Item No.
[12]	M 28 x 60				A 352 054 05 01	20 1003 35260
I [1]					A 352 050 10 33 A 366 050 04 33	20 1003 36602 (1)
	(1) IN					

## 218 97,5

<b>OM 382 Euro 0</b>	<b>970</b>	D (LA)	6	5958 cm <sup>3</sup>	2V	177 kW	(241 PS)	16,5:1	133,00 mm
<b>OM 382 Euro 0</b>	<b>913, 919, 971</b>	D (A)	6	5958 cm <sup>3</sup>	2V	125-150 kW	(170-204 PS)	16,5:1	133,00 mm
90 532 6.., 92 525 7.., 93 831 6..									

	IN [2]	42,0 x 9 x 140,5	A/S - Cr -	- 20° -	-	5 - III	A 366 050 12 26	<b>261100</b>
	IN [2]	42,0 x 9 x 140,5	A/S - Cr -	- 30° -	-	5 - III	A 366 050 03 26	<b>16130</b>
	IN [2]	43,0 x 9 x 140,5	A/S - Cr -	- 30° -	-	5 - III	A 366 050 02 26	<b>16109</b>
	IN [2]	44,0 x 9 x 140,5	A/S - Cr -	- 45° -	-	5 - III	A 352 050 00 26 A 352 050 01 26 A 352 053 01 01	<b>16136</b>
	EX [2]	36,0 x 10 x 140,5	A/S - Cr -	- 45° -	-	5 - III	A 366 050 02 27	<b>16122</b>
	EX [2]	36,0 x 10 x 140,6	A/S - Cr -	- 45° -	-	5 - III	A 321 053 09 05 A 366 050 00 27 A 366 050 01 27 A 366 050 05 27 A 366 050 06 27 A 376 050 00 27 A 376 050 01 27	<b>16106</b>
	IN [1]	43,87 x 34,5 x 7,4	G1				A 366 053 35 31	<b>92-16155</b>
	EX [2]	38,07 x 30 x 7,9	G1 45°				A 366 053 20 32	<b>92-16154</b>
	EX [2]	38,07 x 30 x 8,5	G1 45°				A 366 053 16 32	<b>92-16109</b>
	EX [1]	38,38 x 30 x 8,5	G1 45°				A 352 053 16 32 A 352 053 21 32	<b>92-16131</b>
		739 mm					A 366 050 04 01 A 366 050 06 01 A 366 051 11 01	<b>20 1003 36601</b>
[12]	M 28 x 60						A 352 054 05 01	<b>20 1003 35260</b>
I [1]							A 352 050 10 33 A 366 050 04 33	<b>20 1003 36602 (1)</b>
	(1) IN							

## 219 97,5

<b>OM 376 Euro 0</b>	<b>980 - 982, 987 - 989, 998 - 999</b>	D (LA)	6	5958 cm <sup>3</sup>	2V	127-142 kW	(173-193 PS)	16,5:1	133,00 mm
12.1985→									
93 951 6..									

	IN [2]	42,0 x 9 x 140,5	A/S - Cr -	- 30° -	-	5 - III	A 366 050 03 26	<b>16130</b>	
	IN [2]	43,0 x 9 x 140,5	A/S - Cr -	- 30° -	-	5 - III	A 366 050 02 26	<b>16109</b>	
	IN [2]	44,0 x 9 x 140,5	A/S - Cr -	- 45° -	-	5 - III	A 352 050 00 26 A 352 050 01 26 A 352 053 01 01	<b>16136</b>	
	EX [2]	36,0 x 10 x 140,5	A/S - Cr -	- 45° -	-	5 - III	A 366 050 02 27	<b>16122</b>	
	EX [2]	36,0 x 10 x 140,6	A/S - Cr -	- 45° -	-	5 - III	A 321 053 09 05 A 366 050 00 27 A 366 050 01 27 A 366 050 05 27 A 366 050 06 27 A 376 050 00 27 A 376 050 01 27	<b>16106</b>	
Fortsetzung nächste Seite / continued on next page / suite page suivante / continuación página próxima / Продолжение на следующей странице									



					Reference	Item No.
IN [6]	15,04 x 9 x 72,0	G1			A 352 053 22 29 A 366 053 07 29	<b>81-1674</b>
EX [6]	15,04 x 10 x 67,0	G1			A 352 053 37 30 A 366 053 02 30	<b>81-1676</b>
EX [2]	38,07 x 30 x 8,5	G1 45°			A 366 053 16 32	<b>92-16109</b>
EX [1]	38,38 x 30 x 8,5	G1 45°			A 352 053 16 32 A 352 053 21 32	<b>92-16131</b>
	739 mm				A 366 050 04 01 A 366 050 06 01 A 366 051 11 01	<b>20 1003 36601</b>
[12]	M 28 x 60				A 352 054 05 01	<b>20 1003 35260</b>

## 220

97,5

**OM 376 Euro 0**
**984, 986, 994**

03.1986 →

 D (LA) 6 5958 cm<sup>3</sup> 2V 150-155 kW (204-211 PS) 16,5:1 133,00 mm

IN [2]	42,0 x 9 x 140,5	A/S - Cr -	- 30° - -	5 - III	A 366 050 03 26	<b>16130</b>
IN [2]	43,0 x 9 x 140,5	A/S - Cr -	- 30° - -	5 - III	A 366 050 02 26	<b>16109</b>
IN [2]	44,0 x 9 x 140,5	A/S - Cr -	- 45° - -	5 - III	A 352 050 00 26 A 352 050 01 26 A 352 053 01 01	<b>16136</b>
EX [2]	36,0 x 10 x 140,5	A/S - Cr -	- 45° - -	5 - III	A 366 050 02 27	<b>16122</b>
EX [2]	36,0 x 10 x 140,5	S - Cr -	- 45° - VS -	5 - III	A 352 053 15 05	<b>1604</b>
EX [2]	36,0 x 10 x 140,6	A/S - Cr -	- 45° - -	5 - III	A 321 053 09 05 A 366 050 00 27 A 366 050 01 27 A 366 050 05 27 A 366 050 06 27 A 376 050 00 27 A 376 050 01 27	<b>16106</b>
IN [6]	15,00 x 9 x 78,0	G1			A 312 053 02 30	<b>81-1609</b>
IN [6]	15,04 x 9 x 72,0	G1			A 352 053 22 29 A 366 053 07 29	<b>81-1674</b>
EX [6]	15,04 x 10 x 67,0	G1			A 352 053 37 30 A 366 053 02 30	<b>81-1676</b>
IN [1]	43,87 x 34,5 x 7,4	G1			A 366 053 35 31	<b>92-16155</b>
EX [2]	38,07 x 30 x 8,5	G1 45°			A 366 053 16 32	<b>92-16109</b>
EX [1]	38,38 x 30 x 8,5	G1 45°			A 352 053 16 32 A 352 053 21 32	<b>92-16131</b>
	739 mm				A 366 050 04 01 A 366 050 06 01 A 366 051 11 01	<b>20 1003 36601</b>
[12]	M 28 x 60				A 352 054 05 01	<b>20 1003 35260</b>
I [1]					A 352 050 10 33 A 366 050 04 33	<b>20 1003 36602 (1)</b>
	(1) IN					

## 221

97,5

**OM 364 Euro 1**
**919 - 921**

 04.1986 → 12.1994 D (NA) 4 3972 cm<sup>3</sup> 2V 63 kW (86 PS) 17,3 133,00 mm

91 550 6.., 91 551 6..

Fortsetzung nächste Seite / continued on next page / suite page suivante / continuación página próxima / Продолжение на следующей странице

					Reference	Item No.	
	IN [2]	42,0 x 9 x 140,5	A/S - Cr -	- 20° - -	5 - III	A 366 050 12 26	<b>261100</b>
	IN [2]	42,0 x 9 x 140,5	A/S - Cr -	- 30° - -	5 - III	A 366 050 03 26	<b>16130</b>
	IN [2]	43,0 x 9 x 140,5	A/S - Cr -	- 30° - -	5 - III	A 366 050 02 26	<b>16109</b>
	IN [2]	44,0 x 9 x 140,5	A/S - Cr -	- 45° - -	5 - III	A 352 050 00 26	<b>16136</b>
						A 352 050 01 26	
						A 352 053 01 01	
	EX [2]	36,0 x 10 x 140,5	A/S - Cr -	- 45° - -	5 - III	A 366 050 02 27	<b>16122</b>
	EX [2]	36,0 x 10 x 140,6	A/S - Cr -	- 45° - -	5 - III	A 321 053 09 05	<b>16106</b>
						A 366 050 00 27	
						A 366 050 01 27	
					A 366 050 05 27		
					A 366 050 06 27		
					A 376 050 00 27		
					A 376 050 01 27		
	IN [6]	15,04 x 9 x 72,0	G1			A 352 053 22 29	<b>81-1674</b>
	EX [6]	15,04 x 10 x 67,0	G1			A 366 053 07 29	<b>81-1676</b>
						A 352 053 37 30	
						A 366 053 02 30	
	IN [1]	43,87 x 34.5 x 7,4	G1			A 366 053 35 31	<b>92-16155</b>
	EX [2]	38,07 x 30 x 7,9	G1 45°			A 366 053 20 32	<b>92-16154</b>
	EX [2]	38,07 x 30 x 8,5	G1 45°			A 366 053 16 32	<b>92-16109</b>
	EX [1]	38,38 x 30 x 8,5	G1 45°			A 352 053 16 32	<b>92-16131</b>
						A 352 053 21 32	
					A 364 050 03 01	<b>20 1003 36400</b>	
	[12]	M 28 x 60				A 352 054 05 01	<b>20 1003 35260</b>
	I [1]					A 352 050 10 33	<b>20 1003 36602 (1)</b>
	(1) IN					A 366 050 04 33	
<b>222</b>		<b>97,5</b>					
<b>OM 364 Euro 0</b>							
<b>908 - 909</b>							
02.1987 → 12.1991 D (NA) 4 3972 cm <sup>3</sup> 2V 50 kW (68 PS) 17,25:1 133,00 mm							
93 951 6..							
	IN [2]	42,0 x 9 x 140,5	A/S - Cr -	- 20° - -	5 - III	A 366 050 12 26	<b>261100</b>
	IN [2]	42,0 x 9 x 140,5	A/S - Cr -	- 30° - -	5 - III	A 366 050 03 26	<b>16130</b>
	IN [2]	43,0 x 9 x 140,5	A/S - Cr -	- 30° - -	5 - III	A 366 050 02 26	<b>16109</b>
	IN [2]	44,0 x 9 x 140,5	A/S - Cr -	- 45° - -	5 - III	A 352 050 00 26	<b>16136</b>
						A 352 050 01 26	
						A 352 053 01 01	
	EX [2]	36,0 x 10 x 140,5	A/S - Cr -	- 45° - -	5 - III	A 366 050 02 27	<b>16122</b>
	EX [2]	36,0 x 10 x 140,6	A/S - Cr -	- 45° - -	5 - III	A 321 053 09 05	<b>16106</b>
						A 366 050 00 27	
						A 366 050 01 27	
					A 366 050 05 27		
					A 366 050 06 27		
					A 376 050 00 27		
					A 376 050 01 27		
	IN [1]	43,87 x 34.5 x 7,4	G1			A 366 053 35 31	<b>92-16155</b>
	IN [1]	43,87 x 34.5 x 7,8	G1 30°			A 366 053 09 31	<b>92-16153</b>
						A 366 053 12 31	
						A 366 053 14 31	
IN [1]	44,17 x 34.5 x 7,8	G1 30°				A 366 053 10 31	<b>92-16116</b>
EX [2]	38,07 x 30 x 7,9	G1 45°				A 366 053 20 32	<b>92-16154</b>
EX [2]	38,07 x 30 x 8,5	G1 45°				A 366 053 16 32	<b>92-16109</b>
EX [1]	38,38 x 30 x 8,5	G1 45°				A 352 053 16 32	<b>92-16131</b>
						A 352 053 21 32	

Fortsetzung nächste Seite / continued on next page / suite page suivante / continuación página próxima / Продолжение на следующей странице

					Reference	Item No.
					A 364 050 03 01	20 1003 36400
[12]	M 28 x 60				A 352 054 05 01	20 1003 35260
I [1]					A 352 050 10 33 A 366 050 04 33	20 1003 36602 (1)
	(1) IN					

## 223 97,5

**OM 364 Euro 1 918**  
02.1992 → 12.1998 D (NA) 4 3972 cm<sup>3</sup> 2V 63 kW (86 PS) 19:1 133,00 mm

**OM 364 Euro 0 951**  
03.1987 → 12.1991 D (A) 4 3972 cm<sup>3</sup> 2V 66 kW (90 PS) 16,5:1 133,00 mm

90 532 6..., 91 550 6..., 91 551 6..., 93 831 6..

	IN [2]	42,0 x 9 x 140,5	A/S - Cr -	- 20° - -	5 - III	A 366 050 12 26	261100
	IN [2]	42,0 x 9 x 140,5	A/S - Cr -	- 30° - -	5 - III	A 366 050 03 26	16130
	IN [2]	43,0 x 9 x 140,5	A/S - Cr -	- 30° - -	5 - III	A 366 050 02 26	16109
	IN [2]	44,0 x 9 x 140,5	A/S - Cr -	- 45° - -	5 - III	A 352 050 00 26 A 352 050 01 26 A 352 053 01 01	16136
	EX [2]	36,0 x 10 x 140,5	A/S - Cr -	- 45° - -	5 - III	A 366 050 02 27	16122
	EX [2]	36,0 x 10 x 140,6	A/S - Cr -	- 45° - -	5 - III	A 321 053 09 05 A 366 050 00 27 A 366 050 01 27 A 366 050 05 27 A 366 050 06 27 A 376 050 00 27 A 376 050 01 27	16106
	IN [1]	43,87 x 34,5 x 7,4	G1			A 366 053 35 31	92-16155
	EX [2]	38,07 x 30 x 7,9	G1 45°			A 366 053 20 32	92-16154
	EX [2]	38,07 x 30 x 8,5	G1 45°			A 366 053 16 32	92-16109
	EX [1]	38,38 x 30 x 8,5	G1 45°			A 352 053 16 32 A 352 053 21 32	92-16131
						A 364 050 03 01	20 1003 36400
[12]	M 28 x 60					A 352 054 05 01	20 1003 35260
I [1]						A 352 050 10 33 A 366 050 04 33	20 1003 36602 (1)
	(1) IN						

## 224 97,5

**OM 364 Euro 0 980**  
07.1987 → 12.1992 D (LA) 4 3972 cm<sup>3</sup> 2V 100 kW (136 PS) 16,5:1 133,00 mm

90 532 6..., 93 831 6..

[12]	M 28 x 60					A 352 054 05 01	20 1003 35260
------	-----------	--	--	--	--	-----------------	---------------

## 225 97,5

**OM 376 Euro 0 911-505, 911-506, 911-507, 911-508**  
07.1987 → D (LA) 6 5958 cm<sup>3</sup> 2V 127-172 kW (170-230 PS) 16,5:1 133,00 mm

Fortsetzung nächste Seite / continued on next page / suite page suivante / continuación página próxima / Продолжение на следующей странице

					Reference	Item No.
IN [2] EX [2]	42,0 x 9 x 140,5 36,0 x 10 x 140,6	A/S - Cr - A/S - Cr -	- 20° - - - 45° - -	5 - III 5 - III	A 366 050 12 26 A 321 053 09 05 A 366 050 00 27 A 366 050 01 27 A 366 050 05 27 A 366 050 06 27 A 376 050 00 27 A 376 050 01 27	<b>261100</b> <b>16106</b>
IN [6] EX [6]	15,04 x 9 x 72,0 15,04 x 10 x 67,0	G1 G1			A 352 053 22 29 A 366 053 07 29 A 352 053 37 30 A 366 053 02 30	<b>81-1674</b> <b>81-1676</b>
IN [1] EX [2]	43,87 x 34.5 x 7,4 38,07 x 30 x 7,9	G1 G1 45°			A 366 053 35 31 A 366 053 20 32	<b>92-16155</b> <b>92-16154</b>

## 226 97,5

<b>OM 364 Euro 1</b>	<b>916 - 917</b>	D (NA)	4	3972 cm <sup>3</sup>	2V	58-60 kW	(79-82 PS)	19:1	133,00 mm
<b>OM 364 Euro 0</b>	<b>979</b>	D (A)	4	3972 cm <sup>3</sup>	2V	85 kW	(116 PS)	16,3-16,5	133,00 mm
		03.1988 → 12.2011							

IN [2] IN [2] IN [2] IN [2]	42,0 x 9 x 140,5 42,0 x 9 x 140,5 43,0 x 9 x 140,5 44,0 x 9 x 140,5	A/S - Cr - A/S - Cr - A/S - Cr - A/S - Cr -	- 20° - - - 30° - - - 30° - - - 45° - -	5 - III 5 - III 5 - III 5 - III	A 366 050 12 26 A 366 050 03 26 A 366 050 02 26 A 352 050 00 26 A 352 050 01 26 A 352 053 01 01 A 366 050 02 27 A 321 053 09 05 A 366 050 00 27 A 366 050 01 27 A 366 050 05 27 A 366 050 06 27 A 376 050 00 27 A 376 050 01 27	<b>261100</b> <b>16130</b> <b>16109</b> <b>16136</b>
EX [2] EX [2]	36,0 x 10 x 140,5 36,0 x 10 x 140,6	A/S - Cr - A/S - Cr -	- 45° - - - 45° - -	5 - III 5 - III	A 366 050 02 27 A 321 053 09 05 A 366 050 00 27 A 366 050 01 27 A 366 050 05 27 A 366 050 06 27 A 376 050 00 27 A 376 050 01 27	<b>16122</b> <b>16106</b>
IN [1] EX [2]	43,87 x 34.5 x 7,4 38,07 x 30 x 7,9	G1 G1 45°			A 366 053 35 31 A 366 053 20 32	<b>92-16155</b> <b>92-16154</b>
[12]	M 28 x 60				A 352 054 05 01	<b>20 1003 35260</b>
I [1]  (1) IN					A 352 050 10 33 A 366 050 04 33	<b>20 1003 36602 (1)</b>

## 227 97,5

<b>OM 306 Euro 0</b>	<b>900-510 (ZA)</b>	D (LA)	6	5958 cm <sup>3</sup>	2V	177 kW	(240 PS)	133,00 mm	
		04.1991 →							
<b>OM 306 Euro 0</b>	<b>900-413 (ZA), 900-414, 900-415, 900-416 (ZA)</b>	D (A)	6	5958 cm <sup>3</sup>	2V	125 kW	(170 PS)	16,5:1	133,00 mm
		05.1988 →							
90 532 6..., 92 525 7..., 93 831 6..									

Fortsetzung nächste Seite / continued on next page / suite page suivante / continuación página próxima / Продолжение на следующей странице

					Reference	Item No.	
	IN [2]	42,0 x 9 x 140,5	A/S - Cr -	- 30° - -	5 - III	A 366 050 03 26	<b>16130</b>
	IN [2]	43,0 x 9 x 140,5	A/S - Cr -	- 30° - -	5 - III	A 366 050 02 26	<b>16109</b>
	IN [2]	44,0 x 9 x 140,5	A/S - Cr -	- 45° - -	5 - III	A 352 050 00 26	<b>16136</b>
						A 352 050 01 26	
						A 352 053 01 01	
	EX [2]	36,0 x 10 x 140,5	A/S - Cr -	- 45° - -	5 - III	A 366 050 02 27	<b>16122</b>
	EX [2]	36,0 x 10 x 140,6	A/S - Cr -	- 45° - -	5 - III	A 321 053 09 05	<b>16106</b>
						A 366 050 00 27	
						A 366 050 01 27	
						A 366 050 05 27	
					A 366 050 06 27		
					A 376 050 00 27		
					A 376 050 01 27		
	IN [6]	15,04 x 9 x 72,0	G1			A 352 053 22 29	<b>81-1674</b>
	EX [6]	15,04 x 10 x 67,0	G1			A 366 053 07 29	
	IN [1]	43,87 x 34.5 x 7,4	G1			A 352 053 37 30	<b>81-1676</b>
	EX [2]	38,07 x 30 x 7,9	G1 45°			A 366 053 02 30	
	EX [2]	38,07 x 30 x 8,5	G1 45°			A 366 053 35 31	<b>92-16155</b>
	EX [1]	38,38 x 30 x 8,5	G1 45°			A 366 053 20 32	<b>92-16154</b>
						A 366 053 16 32	<b>92-16109</b>
						A 352 053 16 32	<b>92-16131</b>
						A 352 053 21 32	
						A 352 053 21 32	
	I [1]					A 352 050 10 33	<b>20 1003 36602 (1)</b>
	(1) IN					A 366 050 04 33	

**228**
**97,5**
**OM 306 Euro 0**
**900-417**

05.1988 →

D (A)

6

 5958 cm<sup>3</sup> 2V

125 kW

(170 PS) 16,5:1

133,00 mm

90 532 6.., 93 831 6..

	IN [2]	42,0 x 9 x 140,5	A/S - Cr -	- 30° - -	5 - III	A 366 050 03 26	<b>16130</b>
	IN [2]	43,0 x 9 x 140,5	A/S - Cr -	- 30° - -	5 - III	A 366 050 02 26	<b>16109</b>
	IN [2]	44,0 x 9 x 140,5	A/S - Cr -	- 45° - -	5 - III	A 352 050 00 26	<b>16136</b>
						A 352 050 01 26	
						A 352 053 01 01	
	EX [2]	36,0 x 10 x 140,5	A/S - Cr -	- 45° - -	5 - III	A 366 050 02 27	<b>16122</b>
	EX [2]	36,0 x 10 x 140,6	A/S - Cr -	- 45° - -	5 - III	A 321 053 09 05	<b>16106</b>
						A 366 050 00 27	
						A 366 050 01 27	
						A 366 050 05 27	
					A 366 050 06 27		
					A 376 050 00 27		
					A 376 050 01 27		
	IN [6]	15,04 x 9 x 72,0	G1			A 352 053 22 29	<b>81-1674</b>
	EX [6]	15,04 x 10 x 67,0	G1			A 366 053 07 29	
	IN [1]	43,87 x 34.5 x 7,4	G1			A 352 053 37 30	<b>81-1676</b>
	EX [2]	38,07 x 30 x 7,9	G1 45°			A 366 053 02 30	
	EX [2]	38,07 x 30 x 8,5	G1 45°			A 366 053 35 31	<b>92-16155</b>
	EX [1]	38,38 x 30 x 8,5	G1 45°			A 366 053 20 32	<b>92-16154</b>
						A 366 053 16 32	<b>92-16109</b>
						A 352 053 16 32	<b>92-16131</b>
						A 352 053 21 32	
						A 352 053 21 32	

**229**
**97,5**
**OM 364 Euro 1**
**983**

05.1992 →

D (LA)

4

 3972 cm<sup>3</sup> 2V

102 kW

(139 PS) 18:1

133,00 mm

Fortsetzung nächste Seite / continued on next page / suite page suivante / continuación página próxima / Продолжение на следующей странице



					Reference	Item No.	
	IN [2]	42,0 x 9 x 140,5	A/S - Cr -	- 20° - -	5 - III	A 366 050 12 26	<b>261100</b>
	IN [2]	42,0 x 9 x 140,5	A/S - Cr -	- 30° - -	5 - III	A 366 050 03 26	<b>16130</b>
	IN [2]	43,0 x 9 x 140,5	A/S - Cr -	- 30° - -	5 - III	A 366 050 02 26	<b>16109</b>
	IN [2]	44,0 x 9 x 140,5	A/S - Cr -	- 45° - -	5 - III	A 352 050 00 26	<b>16136</b>
						A 352 050 01 26	
						A 352 053 01 01	
	EX [2]	36,0 x 10 x 140,5	A/S - Cr -	- 45° - -	5 - III	A 366 050 02 27	<b>16122</b>
	EX [2]	36,0 x 10 x 140,6	A/S - Cr -	- 45° - -	5 - III	A 321 053 09 05	<b>16106</b>
						A 366 050 00 27	
						A 366 050 01 27	
					A 366 050 05 27		
					A 366 050 06 27		
					A 376 050 00 27		
					A 376 050 01 27		
	IN [1]	43,87 x 34,5 x 7,4	G1			A 366 053 35 31	<b>92-16155</b>
	EX [2]	38,07 x 30 x 7,9	G1 45°			A 366 053 20 32	<b>92-16154</b>
	EX [2]	38,07 x 30 x 8,5	G1 45°			A 366 053 16 32	<b>92-16109</b>
	[12]	M 28 x 60				A 352 054 05 01	<b>20 1003 35260</b>
	I [1]					A 352 050 10 33	<b>20 1003 36602 (1)</b>
	(1) IN					A 366 050 04 33	

## 230 97,5

OM 356 Euro 1

944

12.1992 → 12.1998 D (A) 6 5958 cm<sup>3</sup> 2V 116 kW (158 PS) 16,5:1 133,00 mm

91 598 6..

	IN [2]	42,0 x 9 x 140,5	A/S - Cr -	- 20° - -	5 - III	A 366 050 12 26	<b>261100</b>
	IN [2]	42,0 x 9 x 140,5	A/S - Cr -	- 30° - -	5 - III	A 366 050 03 26	<b>16130</b>
	IN [2]	43,0 x 9 x 140,5	A/S - Cr -	- 30° - -	5 - III	A 366 050 02 26	<b>16109</b>
	IN [2]	44,0 x 9 x 140,5	A/S - Cr -	- 45° - -	5 - III	A 352 050 00 26	<b>16136</b>
						A 352 050 01 26	
						A 352 053 01 01	
	IN [2]	46,0 x 9 x 141,2	S - Cr -	- 30° - -	1 - III		<b>171019</b>
	EX [2]	36,0 x 10 x 140,5	A/S - Cr -	- 45° - -	5 - III	A 366 050 02 27	<b>16122</b>
	EX [2]	36,0 x 10 x 140,6	A/S - Cr -	- 45° - -	5 - III	A 321 053 09 05	<b>16106</b>
						A 366 050 00 27	
					A 366 050 01 27		
					A 366 050 05 27		
					A 366 050 06 27		
					A 376 050 00 27		
					A 376 050 01 27		
	[50]	Ø 9 mm					<b>KK-9H</b>
	IN [6]	15,00 x 9 x 78,0	G1			A 312 053 02 30	<b>81-1609</b>
	IN [6]	15,04 x 9 x 72,0	G1			A 352 053 22 29	<b>81-1674</b>
	EX [6]	15,04 x 10 x 67,0	G1			A 366 053 07 29	<b>81-1676</b>
					A 352 053 37 30		
					A 366 053 02 30		
	IN [1]	43,87 x 34,5 x 7,4	G1			A 366 053 35 31	<b>92-16155</b>
	EX [2]	38,07 x 30 x 7,9	G1 45°			A 366 053 20 32	<b>92-16154</b>
	EX [2]	38,07 x 30 x 8,5	G1 45°			A 366 053 16 32	<b>92-16109</b>
	EX [1]	38,38 x 30 x 8,5	G1 45°			A 352 053 16 32	<b>92-16131</b>
					A 352 053 21 32		
		739 mm				A 366 050 04 01	<b>20 1003 36601</b>
						A 366 050 06 01	
						A 366 051 11 01	

Fortsetzung nächste Seite / continued on next page / suite page suivante / continuación página próxima / Продолжение на следующей странице

					Reference	Item No.
[12]	M 28 x 60				A 352 054 05 01	20 1003 35260
I [1]					A 352 050 10 33 A 366 050 04 33	20 1003 36602 (1)
	(1) IN					

## 231 97,5

OM 374 989 04.1995 → D (LA) 4 3972 cm<sup>3</sup> 2V 85 kW (115 PS) 16,5:1 133,00 mm  
 OM 374 990 04.1995 → D (LA) 4 3972 cm<sup>3</sup> 2V 85 kW (115 PS) 16,5:1 133,00 mm

IN [2]	42,0 x 9 x 140,5	A/S - Cr -	- 20° - -	5 - III	A 366 050 12 26	261100
EX [2]	36,0 x 10 x 140,6	A/S - Cr -	- 45° - -	5 - III	A 321 053 09 05 A 366 050 00 27 A 366 050 01 27 A 366 050 05 27 A 366 050 06 27 A 376 050 00 27 A 376 050 01 27	16106
IN [6]	15,04 x 9 x 72,0	G1			A 352 053 22 29 A 366 053 07 29	81-1674
EX [6]	15,04 x 10 x 67,0	G1			A 352 053 37 30 A 366 053 02 30	81-1676
IN [1]	43,87 x 34,5 x 7,4	G1			A 366 053 35 31	92-16155
EX [2]	38,07 x 30 x 7,9	G1 45°			A 366 053 20 32	92-16154
I [1]					A 352 050 10 33 A 366 050 04 33	20 1003 36602 (1)
	(1) IN					

## 232 97,5

OM 304 900-001, 900-010 D (A) 4 3972 cm<sup>3</sup> 2V 61 kW (83 PS) 16,5:1 133,00 mm  
 90 532 6.., 93 831 6..

IN [2]	42,0 x 9 x 140,5	A/S - Cr -	- 20° - -	5 - III	A 366 050 12 26	261100
IN [2]	43,0 x 9 x 140,5	A/S - Cr -	- 30° - -	5 - III	A 366 050 02 26	16109
EX [2]	36,0 x 10 x 140,6	A/S - Cr -	- 45° - -	5 - III	A 321 053 09 05 A 366 050 00 27 A 366 050 01 27 A 366 050 05 27 A 366 050 06 27 A 376 050 00 27 A 376 050 01 27	16106
IN [6]	15,04 x 9 x 72,0	G1			A 352 053 22 29 A 366 053 07 29	81-1674
EX [6]	15,04 x 10 x 67,0	G1			A 352 053 37 30 A 366 053 02 30	81-1676
IN [1]	43,87 x 34,5 x 7,4	G1			A 366 053 35 31	92-16155
IN [1]	43,87 x 34,5 x 7,8	G1 30°			A 366 053 09 31 A 366 053 12 31 A 366 053 14 31	92-16153
IN [1]	44,17 x 34,5 x 7,8	G1 30°			A 366 053 10 31	92-16116
EX [2]	38,07 x 30 x 7,9	G1 45°			A 366 053 20 32	92-16154
EX [2]	38,07 x 30 x 8,5	G1 45°			A 366 053 16 32	92-16109
EX [1]	38,38 x 30 x 8,5	G1 45°			A 352 053 16 32 A 352 053 21 32	92-16131
I [1]					A 352 050 10 33 A 366 050 04 33	20 1003 36602 (1)
	(1) IN					

					Reference	Item No.
<b>233</b>		<b>97,5</b>				
<b>OM 366 Euro 0</b>		<b>901/-400</b>		D (A) 6	5958 cm <sup>3</sup> 2V	133,00 mm
90 532 6..., 93 831 6...						
	IN [2]	42,0 x 9 x 140,5	A/S - Cr -	- 20° - -	5 - III	A 366 050 12 26 <b>261100</b>
	IN [2]	42,0 x 9 x 140,5	A/S - Cr -	- 30° - -	5 - III	A 366 050 03 26 <b>16130</b>
	IN [2]	43,0 x 9 x 140,5	A/S - Cr -	- 30° - -	5 - III	A 366 050 02 26 <b>16109</b>
	IN [2]	44,0 x 9 x 140,5	A/S - Cr -	- 45° - -	5 - III	A 352 050 00 26 <b>16136</b>
						A 352 050 01 26
						A 352 053 01 01
	EX [2]	36,0 x 10 x 140,5	A/S - Cr -	- 45° - -	5 - III	A 366 050 02 27 <b>16122</b>
	EX [2]	36,0 x 10 x 140,6	A/S - Cr -	- 45° - -	5 - III	A 321 053 09 05 <b>16106</b>
						A 366 050 00 27
						A 366 050 01 27
						A 366 050 05 27
						A 366 050 06 27
						A 376 050 00 27
						A 376 050 01 27
	IN [6]	15,00 x 9 x 78,0	G1			A 312 053 02 30 <b>81-1609</b>
	IN [6]	15,04 x 9 x 72,0	G1			A 352 053 22 29 <b>81-1674</b>
						A 366 053 07 29
	EX [6]	15,04 x 10 x 67,0	G1			A 352 053 37 30 <b>81-1676</b>
						A 366 053 02 30
	IN [1]	43,87 x 34.5 x 7,4	G1			A 366 053 35 31 <b>92-16155</b>
	IN [1]	43,87 x 34.5 x 7,8	G1 30°			A 366 053 09 31 <b>92-16153</b>
						A 366 053 12 31
						A 366 053 14 31
	IN [1]	44,17 x 34.5 x 7,8	G1 30°			A 366 053 10 31 <b>92-16116</b>
	EX [2]	38,07 x 30 x 8,5	G1 45°			A 366 053 16 32 <b>92-16109</b>
	EX [1]	38,38 x 30 x 8,5	G1 45°			A 352 053 16 32 <b>92-16131</b>
						A 352 053 21 32
		739 mm				A 366 050 04 01 <b>20 1003 36601</b>
						A 366 050 06 01
						A 366 051 11 01
	[12]	M 28 x 60				A 352 054 05 01 <b>20 1003 35260</b>
	I [1]					A 352 050 10 33 <b>20 1003 36602 (1)</b>
						A 366 050 04 33
	(1) IN					
<b>234</b>		<b>97,5</b>				
<b>OM 374 Euro 1</b>		<b>901-000</b>		D (A) 4	3972 cm <sup>3</sup> 2V	133,00 mm
	IN [2]	42,0 x 9 x 140,5	A/S - Cr -	- 30° - -	5 - III	A 366 050 03 26 <b>16130</b>
	IN [2]	43,0 x 9 x 140,5	A/S - Cr -	- 30° - -	5 - III	A 366 050 02 26 <b>16109</b>
	IN [2]	44,0 x 9 x 140,5	A/S - Cr -	- 45° - -	5 - III	A 352 050 00 26 <b>16136</b>
						A 352 050 01 26
						A 352 053 01 01
	EX [2]	36,0 x 10 x 140,5	A/S - Cr -	- 45° - -	5 - III	A 366 050 02 27 <b>16122</b>
	EX [2]	36,0 x 10 x 140,5	S - Cr -	- 45° - VS -	5 - III	A 352 053 15 05 <b>1604</b>
	EX [2]	36,0 x 10 x 140,6	A/S - Cr -	- 45° - -	5 - III	A 321 053 09 05 <b>16106</b>
						A 366 050 00 27
						A 366 050 01 27
						A 366 050 05 27
						A 366 050 06 27
						A 376 050 00 27
						A 376 050 01 27
Fortsetzung nächste Seite / continued on next page / suite page suivante / continuación página próxima / Продолжение на следующей странице						

M

					Reference	Item No.
EX [2]	38,07 x 30 x 8,5	G1 45°			A 366 053 16 32	<b>92-16109</b>
EX [1]	38,38 x 30 x 8,5	G1 45°			A 352 053 16 32 A 352 053 21 32	<b>92-16131</b>
[12]	M 28 x 60				A 352 054 05 01	<b>20 1003 35260</b>
I [1]					A 352 050 10 33 A 366 050 04 33	<b>20 1003 36602 (1)</b>
	(1) IN					

## 235 97,5

OM 376 Euro 0

963, 993

D (LA) 6 5958 cm<sup>3</sup> 2V 125-150 kW (170-204 PS) 16,5:1 133,00 mm

90 532 6..., 92 525 7..., 93 831 6..

IN [2]	42,0 x 9 x 140,5	A/S - Cr -	- 20° - -	5 - III	A 366 050 12 26	<b>261100</b>
IN [2]	42,0 x 9 x 140,5	A/S - Cr -	- 30° - -	5 - III	A 366 050 03 26	<b>16130</b>
IN [2]	43,0 x 9 x 140,5	A/S - Cr -	- 30° - -	5 - III	A 366 050 02 26	<b>16109</b>
IN [2]	44,0 x 9 x 140,5	A/S - Cr -	- 45° - -	5 - III	A 352 050 00 26 A 352 050 01 26 A 352 053 01 01	<b>16136</b>
EX [2]	36,0 x 10 x 140,5	A/S - Cr -	- 45° - -	5 - III	A 366 050 02 27	<b>16122</b>
EX [2]	36,0 x 10 x 140,5	S - Cr -	- 45° - VS -	5 - III	A 352 053 15 05	<b>1604</b>
EX [2]	36,0 x 10 x 140,6	A/S - Cr -	- 45° - -	5 - III	A 321 053 09 05 A 366 050 00 27 A 366 050 01 27 A 366 050 05 27 A 366 050 06 27 A 376 050 00 27 A 376 050 01 27	<b>16106</b>
IN [6]	15,00 x 9 x 78,0	G1			A 312 053 02 30	<b>81-1609</b>
IN [6]	15,04 x 9 x 72,0	G1			A 352 053 22 29 A 366 053 07 29	<b>81-1674</b>
EX [6]	15,04 x 10 x 67,0	G1			A 352 053 37 30 A 366 053 02 30	<b>81-1676</b>
IN [1]	43,87 x 34,5 x 7,4	G1			A 366 053 35 31	<b>92-16155</b>
EX [2]	38,07 x 30 x 8,5	G1 45°			A 366 053 16 32	<b>92-16109</b>
EX [1]	38,38 x 30 x 8,5	G1 45°			A 352 053 16 32 A 352 053 21 32	<b>92-16131</b>
	739 mm				A 366 050 04 01 A 366 050 06 01 A 366 051 11 01	<b>20 1003 36601</b>
[12]	M 28 x 60				A 352 054 05 01	<b>20 1003 35260</b>
I [1]					A 352 050 10 33 A 366 050 04 33	<b>20 1003 36602 (1)</b>
	(1) IN					

## 236 97,5

OM 377 Euro 0

961

D (LA) 6 5958 cm<sup>3</sup> 2V 150-170 kW (204-231 PS) 16,5:1 133,00 mm

Fortsetzung nächste Seite / continued on next page / suite page suivante / continuación página próxima / Продолжение на следующей странице

					Reference	Item No.	
	IN [2]	42,0 x 9 x 140,5	A/S - Cr -	- 20° - -	5 - III	A 366 050 12 26	<b>261100</b>
	IN [2]	42,0 x 9 x 140,5	A/S - Cr -	- 30° - -	5 - III	A 366 050 03 26	<b>16130</b>
	IN [2]	43,0 x 9 x 140,5	A/S - Cr -	- 30° - -	5 - III	A 366 050 02 26	<b>16109</b>
	IN [2]	44,0 x 9 x 140,5	A/S - Cr -	- 45° - -	5 - III	A 352 050 00 26	<b>16136</b>
						A 352 050 01 26	
						A 352 053 01 01	
	EX [2]	36,0 x 10 x 140,5	A/S - Cr -	- 45° - -	5 - III	A 366 050 02 27	<b>16122</b>
	EX [2]	36,0 x 10 x 140,6	A/S - Cr -	- 45° - -	5 - III	A 321 053 09 05	<b>16106</b>
						A 366 050 00 27	
						A 366 050 01 27	
					A 366 050 05 27		
					A 366 050 06 27		
					A 376 050 00 27		
					A 376 050 01 27		
	IN [6]	15,04 x 9 x 72,0	G1			A 352 053 22 29	<b>81-1674</b>
	EX [6]	15,04 x 10 x 67,0	G1			A 366 053 07 29	<b>81-1676</b>
					A 352 053 37 30		
					A 366 053 02 30		
	IN [1]	43,87 x 34.5 x 7,4	G1			A 366 053 35 31	<b>92-16155</b>
	IN [1]	43,87 x 34.5 x 7,8	G1 30°			A 366 053 09 31	<b>92-16153</b>
						A 366 053 12 31	
						A 366 053 14 31	
	IN [1]	44,17 x 34.5 x 7,8	G1 30°			A 366 053 10 31	<b>92-16116</b>
EX [2]	38,07 x 30 x 7,9	G1 45°			A 366 053 20 32	<b>92-16154</b>	
EX [1]	38,38 x 30 x 8,5	G1 45°			A 352 053 16 32	<b>92-16131</b>	
					A 352 053 21 32		
	[12]	M 28 x 60				A 352 054 05 01	<b>20 1003 35260</b>
	I [1]					A 352 050 10 33	<b>20 1003 36602 (1)</b>
	(1) IN					A 366 050 04 33	
<b>237</b> <b>98</b>							
<b>M 157</b> <b>980 - 981, 983</b>							
01.2010→ B (LA) 8 5461 cm <sup>3</sup> 4V 386-430 kW (525-585 PS) 90,50 mm							
<b>M 273</b> <b>960 - 963, 965 - 968, 970 - 971</b>							
10.2005→ B (NA) 8 5461 cm <sup>3</sup> 4V 271-320 kW (369-435 PS) 10,7 90,50 mm							
40 348 6..							
	[8]	H 12 x 34,6 x 34,6				A 160 050 01 80	<b>50 006 432</b>
						A 642 050 00 80	
						A 642 050 01 80	
<b>238</b> <b>102</b>							
<b>OM 902 Euro 4</b> <b>910 - 912, 919 - 921</b>							
D (LA) 6 6374 cm <sup>3</sup> 3V 157-194 kW (213-264 PS) 130,00 mm							
	IN [2]	34,0 x 8 x 125,9	RA/S- Cr -	- 20° - -	1 - III	A 906 050 02 26	<b>16200</b>
	IN [2]	34,0 x 8 x 128,9	RA/S- Cr -	- 20° - -	1 - III	A 906 050 03 26	<b>160056</b>
						A 906 050 06 26	
						A 906 050 07 26	
EX [2]	15,2 x 6 x 81,6	A - -	- 20° - -	9 -		A 906 016 07 91	<b>50 009 053 (1)</b>
EX [2]	38,0 x 8 x 152,6	RA/S- Cr -	- 36° - VS -	1 - III		A 906 050 08 27	<b>16210</b>
						A 906 050 09 27	
EX [2]	38,0 x 8 x 152,7	RA/S- Cr -	- 45° - -	1 - III		A 906 050 03 27	<b>160057</b>
						A 906 050 06 27	
						A 906 050 07 27	
	(1)	Konstantdrosselventil - flach Exhaust brake valve - flat Soupape de réduction permanente - plate Válvula de reducción permanente - plana Постоянный дроссельный клапан					
Fortsetzung nächste Seite / continued on next page / suite page suivante / continuación página próxima / Продолжение на следующей странице							

M



					Reference	Item No.
[50]	Ø 8 mm				A 102 053 00 26	<b>RK-8H</b>
IN/EX [4] IN/EX [4]	13,03 x 8 x 60,0 14,03 x 8 x 60,0	G2 G2			A 906 053 01 29 A 906 053 01 30 A 906 053 05 29	<b>81-16105</b> <b>81-16107</b>
IN [1] IN [1] EX [2]  EX [1] EX [1]	35,08 x 28 x 7,6 35,37 x 28 x 7,7 40,38 x 31 x 8,5  40,08 x 31 x 8,0 40,08 x 31.2 x 8,0	G1 G1 G1 45°  G1 G1			A 906 053 01 31 A 906 053 02 31 A 906 053 02 32 A 906 053 14 32 A 906 053 16 32 A 906 053 01 32 A 906 053 12 32	<b>92-16165</b> <small>NEW</small> <b>92-16159</b> <b>92-16160</b>  <b>92-16167</b> <small>NEW</small> <b>92-16166</b> <small>NEW</small>
	818,5 mm				A 906 050 26 01 A 906 050 32 01 A 906 050 40 01	<b>20 1003 90601</b> <small>NEW</small> <b>20 1003 90605</b>
[12]	M 33 x 18				A 906 054 07 01 A 906 054 10 01	<b>20 1003 90660</b>
	- - - -	- - - EVB			A 906 010 59 21 A 906 010 72 21	<b>20 0803 90602</b>

M

## 239 102

OM 906 Euro 3

999

01.1964 →

D (LA) 6

6374 cm<sup>3</sup>

3V

172-194 kW

(234-264 PS)

130,00 mm

40 031 6..

IN [2] IN [2]	34,0 x 8 x 125,9 34,0 x 8 x 128,9	RA/S- Cr - RA/S- Cr -	- 20° - - - 20° - -	1 - III 1 - III	A 906 050 02 26 A 906 050 03 26 A 906 050 06 26 A 906 050 07 26	<b>16200</b> <b>160056</b>
EX [2] EX [2]	15,2 x 6 x 81,6 38,0 x 8 x 152,6	A - - RA/S- Cr -	- 20° - - - 36° - VS -	9 - 1 - III	A 906 016 07 91 A 906 050 08 27 A 906 050 09 27	<b>50 009 053</b> (1) <b>16210</b>
EX [2]	38,0 x 8 x 152,7	RA/S- Cr -	- 45° - -	1 - III	A 906 050 03 27 A 906 050 06 27 A 906 050 07 27	<b>160057</b>
(1) Konstantdrosselventil - flach Exhaust brake valve - flat Soupape de réduction permanente - plate Válvula de reducción permanente - plana Постоянный дроссельный клапан						
[50]	Ø 8 mm				A 102 053 00 26	<b>RK-8H</b>
IN/EX [4] IN/EX [4]	13,03 x 8 x 60,0 14,03 x 8 x 60,0	G2 G2			A 906 053 01 29 A 906 053 01 30 A 906 053 05 29	<b>81-16105</b> <b>81-16107</b>
IN [1] IN [1] EX [2]  EX [1] EX [1]	35,08 x 28 x 7,6 35,37 x 28 x 7,7 40,38 x 31 x 8,5  40,08 x 31 x 8,0 40,08 x 31.2 x 8,0	G1 G1 G1 45°  G1 G1			A 906 053 01 31 A 906 053 02 31 A 906 053 02 32 A 906 053 14 32 A 906 053 16 32 A 906 053 01 32 A 906 053 12 32	<b>92-16165</b> <small>NEW</small> <b>92-16159</b> <b>92-16160</b>  <b>92-16167</b> <small>NEW</small> <b>92-16166</b> <small>NEW</small>

Fortsetzung nächste Seite / continued on next page / suite page suivante / continuación página próxima / Продолжение на следующей странице

					Reference	Item No.
					A 906 050 32 01 A 906 050 40 01	20 1003 90605
	- - - -	- - - EVB			A 906 010 59 21 A 906 010 72 21	20 0803 90602

## 240 102

<b>OM 904 Euro 2</b>	<b>905 - 907, 912, 918 - 919, 921, 924 - 925, 935, 938, 943, 945</b>	D (LA)	4	4249 cm <sup>3</sup>	3V	90-134 kW	(122-182 PS)	17,4:1	130,00 mm
<b>OM 904 Euro 3</b>	<b>957, 962, 966, 968, 970</b>	D (LA)	4	4249 cm <sup>3</sup>	3V	110-130 kW	(150-177 PS)	17,4:1	130,00 mm

94 705 6.., 94 706 6.., 94 707 6.., 94 971 6..

	IN [2] IN [2]	34,0 x 8 x 125,9 34,0 x 8 x 128,9	RA/S- Cr - RA/S- Cr -	- 20° - - - 20° - -	1 - III 1 - III	A 906 050 02 26 A 906 050 03 26 A 906 050 06 26 A 906 050 07 26	16200 160056	
	EX [2] EX [2]	15,2 x 6 x 81,6 38,0 x 8 x 152,6	A - - RA/S- Cr -	- 20° - - - 36° - VS -	9 - 1 - III	A 906 016 07 91 A 906 050 08 27 A 906 050 09 27	50 009 053 (1) 16210	
	EX [2]	38,0 x 8 x 152,7	RA/S- Cr -	- 45° - -	1 - III	A 906 050 03 27 A 906 050 06 27 A 906 050 07 27	160057	
	(1)	Konstantdrosselventil - flach Exhaust brake valve - flat Soupape de réduction permanente - plate Válvula de reducción permanente - plana Постоянный дроссельный клапан						
	[50]	Ø 8 mm				A 102 053 00 26	RK-8H	
	IN/EX [4] IN/EX [4]	13,03 x 8 x 60,0 14,03 x 8 x 60,0	G2 G2			A 906 053 01 29 A 906 053 01 30 A 906 053 05 29	81-16105 81-16107	
	IN [1] IN [1] EX [2]  EX [1]	35,08 x 28 x 7,6 35,37 x 28 x 7,7 40,38 x 31 x 8,5  40,08 x 31.2 x 8,0	G1 G1 G1 45°  G1			A 906 053 01 31 A 906 053 02 31 A 906 053 02 32 A 906 053 14 32 A 906 053 01 32 A 906 053 12 32	92-16165 <b>NEW</b> 92-16159 92-16160  92-16166 <b>NEW</b>	
						A 904 050 04 01 A 904 050 09 01 A 904 050 40 01	20 1003 90400	
	[12]	M 33 x 18				A 906 054 07 01 A 906 054 10 01	20 1003 90660	

## 241 102

<b>OM 906 Euro 2</b>	<b>918</b>	01.1970 →	D (A)	6	6374 cm <sup>3</sup>	3V	180 kW	(245 PS)	17,4:1	130,00 mm
<b>OM 906 Euro 3</b>	<b>953, 985, 988</b>		D (LA)	6	6374 cm <sup>3</sup>	3V	180-205 kW	(245-279 PS)	17,4:1	130,00 mm
<b>OM 906 Euro 2/3</b>	<b>971</b>		D (LA)	6	6374 cm <sup>3</sup>	3V	170-180 kW	(231-245 PS)	17,4-18	130,00 mm
<b>OM 906 Euro 2</b>	<b>917, 924, 932 - 933, 945, 947, 959, 966</b>		D (LA)	6	6374 cm <sup>3</sup>	3V	157-209 kW	(214-284 PS)		130,00 mm

94 705 6.., 94 706 6.., 94 707 6.., 94 931 6.., 94 932 6.., 94 933 6.., 94 971 6..

Fortsetzung nächste Seite / continued on next page / suite page suivante / continuación página próxima / Продолжение на следующей странице

					Reference	Item No.
	IN [2] 34,0 x 8 x 125,9 IN [2] 34,0 x 8 x 128,9	RA/S- Cr - RA/S- Cr -	- 20° - - - 20° - -	1 - III 1 - III	A 906 050 02 26 A 906 050 03 26 A 906 050 06 26 A 906 050 07 26	<b>16200</b> <b>160056</b>
	EX [2] 15,2 x 6 x 81,6 EX [2] 38,0 x 8 x 152,6	A - - RA/S- Cr -	- 20° - - - 36° - VS -	9 - 1 - III	A 906 016 07 91 A 906 050 08 27 A 906 050 09 27	<b>50 009 053</b> (1) <b>16210</b>
	EX [2] 38,0 x 8 x 152,7	RA/S- Cr -	- 45° - -	1 - III	A 906 050 03 27 A 906 050 06 27 A 906 050 07 27	<b>160057</b>
	(1) Konstantdrosselventil - flach Exhaust brake valve - flat Soupape de réduction permanente - plate Válvula de reducción permanente - plana Постоянный дроссельный клапан					
	[50] Ø 8 mm				A 102 053 00 26	<b>RK-8H</b>
	IN/EX [4] 13,03 x 8 x 60,0 IN/EX [4] 14,03 x 8 x 60,0	G2 G2			A 906 053 01 29 A 906 053 01 30 A 906 053 05 29	<b>81-16105</b> <b>81-16107</b>
	IN [1] 35,08 x 28 x 7,6 IN [1] 35,37 x 28 x 7,7 EX [2] 40,38 x 31 x 8,5	G1 G1 G1 45°			A 906 053 01 31 A 906 053 02 31 A 906 053 02 32 A 906 053 14 32	<b>92-16165</b> <b>92-16159</b> <b>92-16160</b>
	EX [1] 40,08 x 31 x 8,0 EX [1] 40,08 x 31.2 x 8,0	G1 G1			A 906 053 16 32 A 906 053 01 32 A 906 053 12 32	<b>92-16167</b> <b>92-16166</b>
	817,5 mm				A 906 050 09 01 A 906 050 14 01 A 906 050 42 01	<b>20 1003 90600</b>
	[12] M 33 x 18				A 906 054 07 01 A 906 054 10 01	<b>20 1003 90660</b>
	- - - - 	- - - - - - - - EVB			A 906 010 59 21 A 906 010 72 21	<b>20 0803 90602</b>

## 242 102

<b>OM 900</b>	<b>910</b>	D (LA)	4	4249 cm <sup>3</sup>	3V	128 kW	(174 PS)	17,4:1	130,00 mm
<b>OM 900 Euro 4</b>	<b>922</b>	D (LA)	4	4249 cm <sup>3</sup>	3V	95-115 kW	(129-156 PS)	17,4:1	130,00 mm
<b>OM 904 Euro 3</b>	<b>967, 972 - 973, 976</b>	D (LA)	4	4249 cm <sup>3</sup>	3V	130 kW	(177 PS)	17,4:1	130,00 mm
<b>OM 904 Euro 2</b>	<b>904, 908 - 911, 914 - 917, 920, 923, 932, 939 - 940, 954, 956, 974, 980</b>	D (LA)	4	4249 cm <sup>3</sup>	3V	75-147 kW	(102-200 PS)		130,00 mm

40 030 6..., 40 831 6..., 94 705 6..., 94 706 6..., 94 707 6..., 94 931 6..., 94 932 6..., 94 933 6..., 94 971 6..

Fortsetzung nächste Seite / continued on next page / suite page suivante / continuación página próxima / Продолжение на следующей странице

					Reference	Item No.
	IN [2] 34,0 x 8 x 125,9 IN [2] 34,0 x 8 x 128,9	RA/S- Cr - RA/S- Cr -	- 20° - - - 20° - -	1 - III 1 - III	A 906 050 02 26 A 906 050 03 26 A 906 050 06 26 A 906 050 07 26	<b>16200</b> <b>160056</b>
	EX [2] 15,2 x 6 x 81,6 EX [2] 38,0 x 8 x 152,6	A - - RA/S- Cr -	- 20° - - - 36° - VS -	9 - 1 - III	A 906 016 07 91 A 906 050 08 27 A 906 050 09 27	<b>50 009 053</b> (1) <b>16210</b>
	EX [2] 38,0 x 8 x 152,7	RA/S- Cr -	- 45° - -	1 - III	A 906 050 03 27 A 906 050 06 27 A 906 050 07 27	<b>160057</b>
	(1) Konstantdrosselventil - flach Exhaust brake valve - flat Soupape de réduction permanente - plate Válvula de reducción permanente - plana Постоянный дроссельный клапан					
	[50] Ø 8 mm				A 102 053 00 26	<b>RK-8H</b>
	IN/EX [4] 13,03 x 8 x 60,0 IN/EX [4] 14,03 x 8 x 60,0	G2 G2			A 906 053 01 29 A 906 053 01 30 A 906 053 05 29	<b>81-16105</b> <b>81-16107</b>
	IN [1] 35,08 x 28 x 7,6 IN [1] 35,37 x 28 x 7,7 EX [2] 40,38 x 31 x 8,5	G1 G1 G1 45°			A 906 053 01 31 A 906 053 02 31 A 906 053 02 32 A 906 053 14 32	<b>92-16165</b> <b>92-16159</b> <b>92-16160</b>
	EX [1] 40,08 x 31 x 8,0 EX [1] 40,08 x 31,2 x 8,0	G1 G1			A 906 053 16 32 A 906 053 01 32 A 906 053 12 32	<b>92-16167</b> <b>92-16166</b>
					A 904 050 04 01 A 904 050 09 01 A 904 050 40 01	<b>20 1003 90400</b>
	[12] M 33 x 18				A 906 054 07 01 A 906 054 10 01	<b>20 1003 90660</b>

## 243 102

<b>OM 904 Euro 2</b>	<b>926, 929, 931, 933 - 934, 937</b>	07.1987→	D (LA)	4	4249 cm <sup>3</sup>	3V	113-142 kW	(154-193 PS)	17,4:1	130,00 mm
<b>OM 907 Euro 2</b>	<b>960, 970, 980, 990</b>	12.1995→	D (LA)	4	4249 cm <sup>3</sup>	3V	75-125 kW	(102-170 PS)	17,4:1	130,00 mm

94 705 6..., 94 706 6..., 94 707 6..., 94 971 6..

	IN [2] 34,0 x 8 x 125,9 IN [2] 34,0 x 8 x 128,9	RA/S- Cr - RA/S- Cr -	- 20° - - - 20° - -	1 - III 1 - III	A 906 050 02 26 A 906 050 03 26 A 906 050 06 26 A 906 050 07 26	<b>16200</b> <b>160056</b>
	EX [2] 15,2 x 6 x 81,6 EX [2] 38,0 x 8 x 152,6	A - - RA/S- Cr -	- 20° - - - 36° - VS -	9 - 1 - III	A 906 016 07 91 A 906 050 08 27 A 906 050 09 27	<b>50 009 053</b> (1) <b>16210</b>
	EX [2] 38,0 x 8 x 152,7	RA/S- Cr -	- 45° - -	1 - III	A 906 050 03 27 A 906 050 06 27 A 906 050 07 27	<b>160057</b>
	(1) Konstantdrosselventil - flach Exhaust brake valve - flat Soupape de réduction permanente - plate Válvula de reducción permanente - plana Постоянный дроссельный клапан					
	[50] Ø 8 mm				A 102 053 00 26	<b>RK-8H</b>
	IN/EX [4] 13,03 x 8 x 60,0 IN/EX [4] 14,03 x 8 x 60,0	G2 G2			A 906 053 01 29 A 906 053 01 30 A 906 053 05 29	<b>81-16105</b> <b>81-16107</b>

Fortsetzung nächste Seite / continued on next page / suite page suivante / continuación página próxima / Продолжение на следующей странице

					Reference	Item No.
	IN [1] IN [1] EX [2]	35,08 x 28 x 7,6 35,37 x 28 x 7,7 40,38 x 31 x 8,5	G1 G1 G1 45°		A 906 053 01 31 A 906 053 02 31 A 906 053 02 32 A 906 053 14 32	<b>92-16165</b> <small>NEW</small> <b>92-16159</b> <b>92-16160</b>
					A 904 050 04 01 A 904 050 09 01 A 904 050 40 01	<b>20 1003 90400</b>
	[12]	M 33 x 18			A 906 054 07 01 A 906 054 10 01	<b>20 1003 90660</b>

## 244 102

<b>OM 904 Euro 3</b>	<b>927 - 928, 936, 942, 947, 951 - 953, 955, 961, 964, 971, 975</b>	01.1988 →	D (LA)	4	4249 cm <sup>3</sup>	3V	75-130 kW	(102-177 PS)	130,00 mm
<b>OM 904 Euro 2</b>	<b>903, 930, 941, 944, 946, 948 - 950, 959, 979</b>	12.1995 →	D (LA)	4	4249 cm <sup>3</sup>	3V	90-130 kW	(122-177 PS)	130,00 mm
<b>OM 904 Euro 2</b>	<b>922</b>	01.1998 →	D (A)	4	4249 cm <sup>3</sup>	3V	112 kW	(152 PS) 17,4:1	130,00 mm
<b>OM 907 Euro 2</b>	<b>910, 920, 930, 940 - 941</b>	08.1995 →	D (LA)	4	4249 cm <sup>3</sup>	3V	75-125 kW	(102-170 PS) 17,4:1	130,00 mm

94 705 6..., 94 706 6..., 94 707 6..., 94 931 6..., 94 932 6..., 94 933 6..., 94 971 6...

	IN [2] IN [2]	34,0 x 8 x 125,9 34,0 x 8 x 128,9	RA/S- Cr - RA/S- Cr -	- 20° - - - 20° - -	1 - III 1 - III	A 906 050 02 26 A 906 050 03 26 A 906 050 06 26 A 906 050 07 26	<b>16200</b> <b>160056</b>
	EX [2] EX [2]	15,2 x 6 x 81,6 38,0 x 8 x 152,6	A - - RA/S- Cr -	- 20° - - - 36° - VS -	9 - 1 - III	A 906 016 07 91 A 906 050 08 27 A 906 050 09 27	<b>50 009 053</b> (1) <b>16210</b>
	EX [2]	38,0 x 8 x 152,7	RA/S- Cr -	- 45° - -	1 - III	A 906 050 03 27 A 906 050 06 27 A 906 050 07 27	<b>160057</b>
	(1)	Konstantdrosselventil - flach Exhaust brake valve - flat Soupape de réduction permanente - plate Válvula de reducción permanente - plana Постоянный дроссельный клапан					
	[50]	∅ 8 mm				A 102 053 00 26	<b>RK-8H</b>
	IN/EX [4] IN/EX [4]	13,03 x 8 x 60,0 14,03 x 8 x 60,0	G2 G2			A 906 053 01 29 A 906 053 01 30 A 906 053 05 29	<b>81-16105</b> <b>81-16107</b>
	IN [1] IN [1] EX [2]	35,08 x 28 x 7,6 35,37 x 28 x 7,7 40,38 x 31 x 8,5	G1 G1 G1 45°			A 906 053 01 31 A 906 053 02 31 A 906 053 02 32 A 906 053 14 32	<b>92-16165</b> <small>NEW</small> <b>92-16159</b> <b>92-16160</b>
	EX [1]	40,08 x 31 x 8,0	G1			A 906 053 16 32	<b>92-16167</b> <small>NEW</small>
						A 904 050 04 01 A 904 050 09 01 A 904 050 40 01	<b>20 1003 90400</b>
	[12]	M 33 x 18				A 906 054 07 01 A 906 054 10 01	<b>20 1003 90660</b>



					Reference	Item No.
<b>245</b>		<b>102</b>				
<b>OM 906 Euro 2</b>	<b>913 - 914</b>	02.2006 →	D (LA)	6	6374 cm <sup>3</sup> 3V	157-170 kW (231 PS) 17,4:1 130,00 mm
<b>OM 906 Euro 2</b>	<b>915 - 916, 919 - 923, 940</b>	01.1998 →	D (A)	6	6374 cm <sup>3</sup> 3V	170-205 kW (231-279 PS) 130,00 mm
<b>OM 906 Euro 3</b>	<b>925 - 927, 960</b>	01.1998 →	D (LA)	6	6374 cm <sup>3</sup> 3V	170-205 kW (231-279 PS) 130,00 mm
<b>OM 909 Euro 2</b>	<b>910 - 911, 920 - 921</b>	08.1995 →	D (LA)	6	6374 cm <sup>3</sup> 3V	170-205 kW (231-279 PS) 17,4:1 130,00 mm
40 031 6..., 94 705 6..., 94 706 6..., 94 707 6..., 94 931 6..., 94 932 6..., 94 933 6..., 94 971 6..						
	IN [2]	34,0 x 8 x 125,9	RA/S- Cr -	- 20° -	- 1 - III	A 906 050 02 26 <b>16200</b>
	IN [2]	34,0 x 8 x 128,9	RA/S- Cr -	- 20° -	- 1 - III	A 906 050 03 26 <b>160056</b>
	EX [2]	15,2 x 6 x 81,6	A - -	- 20° -	- 9 -	A 906 050 06 26 A 906 050 07 26 A 906 016 07 91 <b>50 009 053 (1)</b>
	EX [2]	38,0 x 8 x 152,6	RA/S- Cr -	- 36° - VS -	- 1 - III	A 906 050 08 27 <b>16210</b>
	EX [2]	38,0 x 8 x 152,7	RA/S- Cr -	- 45° -	- 1 - III	A 906 050 09 27 A 906 050 03 27 A 906 050 06 27 A 906 050 07 27 <b>160057</b>
	(1) Konstantdrosselventil - flach Exhaust brake valve - flat Soupape de réduction permanente - plate Válvula de reducción permanente - plana Постоянный дроссельный клапан					
	[50]	Ø 8 mm				A 102 053 00 26 <b>RK-8H</b>
	IN/EX [4]	13,03 x 8 x 60,0	G2			A 906 053 01 29 <b>81-16105</b>
	IN/EX [4]	14,03 x 8 x 60,0	G2			A 906 053 01 30 A 906 053 05 29 <b>81-16107</b>
	IN [1]	35,08 x 28 x 7,6	G1			A 906 053 01 31 <b>92-16165 NEW</b>
	IN [1]	35,37 x 28 x 7,7	G1			A 906 053 02 31 <b>92-16159</b>
	EX [2]	40,38 x 31 x 8,5	G1 45°			A 906 053 02 32 A 906 053 14 32 <b>92-16160</b>
	EX [1]	40,08 x 31 x 8,0	G1			A 906 053 16 32 <b>92-16167 NEW</b>
		818,5 mm				A 906 050 26 01 <b>20 1003 90601 NEW</b>
	[12]	M 33 x 18				A 906 054 07 01 A 906 054 10 01 <b>20 1003 90660</b>
		- - - -	- - - -	- EVB		A 906 010 59 21 A 906 010 72 21 <b>20 0803 90602</b>
<b>246</b>		<b>102</b>				
<b>OM 906 Euro 2</b>	<b>930</b>	01.1998 →	D (A)	6	6374 cm <sup>3</sup> 3V	205 kW (279 PS) 17,4:1 130,00 mm
<b>OM 906 Euro 2</b>	<b>934</b>	01.1999 →	D (LA)	6	6374 cm <sup>3</sup> 3V	209 kW (284 PS) 17,4:1 130,00 mm
<b>OM 909 Euro 2</b>	<b>971</b>	08.1995 →	D (LA)	6	6374 cm <sup>3</sup> 3V	205 kW (279 PS) 17,4:1 130,00 mm
94 705 6..., 94 706 6..., 94 707 6..., 94 971 6..						
Fortsetzung nächste Seite / continued on next page / suite page suivante / continuación página próxima / Продолжение на следующей странице						

M

					Reference	Item No.
	IN [2] 34,0 x 8 x 125,9	RA/S- Cr -	- 20° - -	1 - III	A 906 050 02 26	<b>16200</b>
	IN [2] 34,0 x 8 x 128,9	RA/S- Cr -	- 20° - -	1 - III	A 906 050 03 26 A 906 050 06 26 A 906 050 07 26	<b>160056</b>
	EX [2] 15,2 x 6 x 81,6	A - -	- 20° - -	9 -	A 906 016 07 91	<b>50 009 053</b> (1)
	EX [2] 38,0 x 8 x 152,6	RA/S- Cr -	- 36° - VS -	1 - III	A 906 050 08 27 A 906 050 09 27	<b>16210</b>
	EX [2] 38,0 x 8 x 152,7	RA/S- Cr -	- 45° - -	1 - III	A 906 050 03 27 A 906 050 06 27 A 906 050 07 27	<b>160057</b>
(1) Konstantdrosselventil - flach Exhaust brake valve - flat Soupape de réduction permanente - plate Válvula de reducción permanente - plana Постоянный дроссельный клапан						
	[50] Ø 8 mm				A 102 053 00 26	<b>RK-8H</b>
	IN/EX [4] 13,03 x 8 x 60,0	G2			A 906 053 01 29	<b>81-16105</b>
	IN/EX [4] 14,03 x 8 x 60,0	G2			A 906 053 01 30 A 906 053 05 29	<b>81-16107</b>
	IN [1] 35,08 x 28 x 7,6	G1			A 906 053 01 31	<b>92-16165</b> <small>NEW</small>
	IN [1] 35,37 x 28 x 7,7	G1			A 906 053 02 31	<b>92-16159</b>
	EX [2] 40,38 x 31 x 8,5	G1 45°			A 906 053 02 32 A 906 053 14 32	<b>92-16160</b>
	817,5 mm				A 906 050 09 01 A 906 050 14 01 A 906 050 42 01	<b>20 1003 90600</b>
	[12] M 33 x 18				A 906 054 07 01 A 906 054 10 01	<b>20 1003 90660</b>
	- - - -	- - - -	- EVB		A 906 010 59 21 A 906 010 72 21	<b>20 0803 90602</b>

## 247 102

<b>OM 906 Euro 2</b>	<b>941</b>								
	01.1998 →	D (A)	6	6374 cm <sup>3</sup>	3V	205 kW	(279 PS)	17,4:1	130,00 mm
<b>OM 906 Euro 2</b>	<b>937</b>								
	01.1998 →	D (LA)	6	6374 cm <sup>3</sup>	3V	170 kW	(231 PS)	17,4:1	130,00 mm
<b>OM 909 Euro 2</b>	<b>970</b>								
	08.1995 →	D (LA)	6	6374 cm <sup>3</sup>	3V	205 kW	(279 PS)	17,4:1	130,00 mm

94 705 6..., 94 706 6..., 94 707 6..., 94 971 6..

	IN [2] 34,0 x 8 x 125,9	RA/S- Cr -	- 20° - -	1 - III	A 906 050 02 26	<b>16200</b>
	IN [2] 34,0 x 8 x 128,9	RA/S- Cr -	- 20° - -	1 - III	A 906 050 03 26 A 906 050 06 26 A 906 050 07 26	<b>160056</b>
	EX [2] 15,2 x 6 x 81,6	A - -	- 20° - -	9 -	A 906 016 07 91	<b>50 009 053</b> (1)
	EX [2] 38,0 x 8 x 152,6	RA/S- Cr -	- 36° - VS -	1 - III	A 906 050 08 27 A 906 050 09 27	<b>16210</b>
	EX [2] 38,0 x 8 x 152,7	RA/S- Cr -	- 45° - -	1 - III	A 906 050 03 27 A 906 050 06 27 A 906 050 07 27	<b>160057</b>

Fortsetzung nächste Seite / continued on next page / suite page suivante / continuación página próxima / Продолжение на следующей странице

					Reference	Item No.
(1)	Konstantdrosselventil - flach Exhaust brake valve - flat Soupape de réduction permanente - plate Válvula de reducción permanente - plana Постоянный дроссельный клапан					
[50]	Ø 8 mm				A 102 053 00 26	<b>RK-8H</b>
IN/EX [4]	13,03 x 8 x 60,0	G2			A 906 053 01 29	<b>81-16105</b>
IN/EX [4]	14,03 x 8 x 60,0	G2			A 906 053 01 30 A 906 053 05 29	<b>81-16107</b>
IN [1]	35,08 x 28 x 7,6	G1			A 906 053 01 31	<b>92-16165</b>
IN [1]	35,37 x 28 x 7,7	G1			A 906 053 02 31	<b>92-16159</b>
EX [2]	40,38 x 31 x 8,5	G1 45°			A 906 053 02 32 A 906 053 14 32	<b>92-16160</b>
	818,5 mm				A 906 050 26 01	<b>20 1003 90601</b>
[12]	M 33 x 18				A 906 054 07 01 A 906 054 10 01	<b>20 1003 90660</b>
	- - - -	- - - - EVB			A 906 010 59 21 A 906 010 72 21	<b>20 0803 90602</b>

**248**
**102**
**OM 909 Euro 2**
**960**

1996 →

D (LA)

6

 6374 cm<sup>3</sup> 3V

170 kW

(231 PS) 17,4:1

130,00 mm

94 705 6..., 94 706 6..., 94 707 6..., 94 971 6..

IN [2]	34,0 x 8 x 125,9	RA/S- Cr -	- 20° - -	1 - III	A 906 050 02 26	<b>16200</b>
IN [2]	34,0 x 8 x 128,9	RA/S- Cr -	- 20° - -	1 - III	A 906 050 03 26 A 906 050 06 26 A 906 050 07 26	<b>160056</b>
EX [2]	15,2 x 6 x 81,6	A - -	- 20° - -	9 -	A 906 016 07 91	<b>50 009 053</b> (1)
EX [2]	38,0 x 8 x 152,6	RA/S- Cr -	- 36° - VS -	1 - III	A 906 050 08 27 A 906 050 09 27	<b>16210</b>
EX [2]	38,0 x 8 x 152,7	RA/S- Cr -	- 45° - -	1 - III	A 906 050 03 27 A 906 050 06 27 A 906 050 07 27	<b>160057</b>
(1)	Konstantdrosselventil - flach Exhaust brake valve - flat Soupape de réduction permanente - plate Válvula de reducción permanente - plana Постоянный дроссельный клапан					
[50]	Ø 8 mm				A 102 053 00 26	<b>RK-8H</b>
IN/EX [4]	13,03 x 8 x 60,0	G2			A 906 053 01 29	<b>81-16105</b>
IN/EX [4]	14,03 x 8 x 60,0	G2			A 906 053 01 30 A 906 053 05 29	<b>81-16107</b>
IN [1]	35,08 x 28 x 7,6	G1			A 906 053 01 31	<b>92-16165</b>
IN [1]	35,37 x 28 x 7,7	G1			A 906 053 02 31	<b>92-16159</b>
EX [2]	40,38 x 31 x 8,5	G1 45°			A 906 053 02 32 A 906 053 14 32	<b>92-16160</b>
EX [1]	40,08 x 31 x 8,0	G1			A 906 053 16 32	<b>92-16167</b>

Fortsetzung nächste Seite / continued on next page / suite page suivante / continuación página próxima / Продолжение на следующей странице

					Reference	Item No.
	818,5 mm				A 906 050 26 01	20 1003 90601 <b>NEW</b>
[12]	M 33 x 18				A 906 054 07 01 A 906 054 10 01	20 1003 90660

## 249 102

**OM 900 Euro 4 911 - 913, 915 - 921**  
 D (LA) 4 4249 cm<sup>3</sup> 3V 95-130 kW (129-177 PS) 130,00 mm  
 40 030 6.., 40 831 6..

	IN [2] IN [2]	34,0 x 8 x 125,9 34,0 x 8 x 128,9	RA/S- Cr - RA/S- Cr -	- 20° - - - 20° - -	1 - III 1 - III	A 906 050 02 26 A 906 050 03 26 A 906 050 06 26 A 906 050 07 26	16200 160056
	EX [2] EX [2]	15,2 x 6 x 81,6 38,0 x 8 x 152,6	A - - RA/S- Cr -	- 20° - - - 36° - VS -	9 - 1 - III	A 906 016 07 91 A 906 050 08 27 A 906 050 09 27 A 906 050 03 27 A 906 050 06 27 A 906 050 07 27	50 009 053 (1) 16210 160057
	EX [2]	38,0 x 8 x 152,7	RA/S- Cr -	- 45° - -	1 - III	A 906 050 03 27 A 906 050 06 27 A 906 050 07 27	
	(1) Konstantdrosselventil - flach Exhaust brake valve - flat Soupape de réduction permanente - plate Válvula de reducción permanente - plana Постоянный дроссельный клапан						
[50]		Ø 8 mm				A 102 053 00 26	RK-8H
	IN/EX [4] IN/EX [4]	13,03 x 8 x 60,0 14,03 x 8 x 60,0	G2 G2			A 906 053 01 29 A 906 053 01 30 A 906 053 05 29	81-16105 81-16107
	IN [1] IN [1] EX [2]	35,08 x 28 x 7,6 35,37 x 28 x 7,7 40,38 x 31 x 8,5	G1 G1 G1 45°			A 906 053 01 31 A 906 053 02 31 A 906 053 02 32 A 906 053 14 32	92-16165 <b>NEW</b> 92-16159 92-16160
	EX [1] EX [1]	40,08 x 31 x 8,0 40,08 x 31.2 x 8,0	G1 G1			A 906 053 16 32 A 906 053 01 32 A 906 053 12 32	92-16167 <b>NEW</b> 92-16166 <b>NEW</b>
[12]		M 33 x 18				A 906 054 07 01 A 906 054 10 01	20 1003 90660

## 250 102

**4-390 11.1996→**  
 D (NA) 4 3922 cm<sup>3</sup> 2V 59-110 kW (80-150 PS) 8,8 120,00 mm  
 94 953 6..

	IN [2]	35,0 x 7 x 101,5	S - Ni -	- 45° - -	9 -	A 104 053 12 01 A 104 053 14 01 A 111 053 11 01 A 111 053 21 01 A 111 053 23 01 A 111 053 24 01 A 111 050 12 27	26048 260490
[50]		Ø 7 mm					RK-7H
	IN/EX [4] IN/EX [4]	12,56 x 7.02 x 37,5 12,70 x 7.02 x 37,5	G1 G1			A 111 053 10 29 A 111 053 11 29	81-26172 81-26173
[8]		H 35 x 24 x 24				A 104 050 12 25	50 006 421

					Reference	Item No.
<b>251</b>		<b>102</b>				
<b>OM 902 Euro 4</b>	<b>913 - 916, 923, 925</b>	D (LA) 6	6374 cm <sup>3</sup>	3V	175-210 kW (238-286 PS)	17,4:1 130,00 mm
<b>OM 906 Euro 2</b>	<b>954, 956</b>	D (LA) 6	6374 cm <sup>3</sup>	3V	172-209 kW (234-284 PS)	17,4:1 130,00 mm
	01.1998 →					
40 030 6.., 40 831 6.., 94 705 6.., 94 706 6.., 94 707 6.., 94 971 6..						
	IN [2]	34,0 x 8 x 125,9	RA/S- Cr -	- 20° - -	1 - III	A 906 050 02 26 <b>16200</b>
	IN [2]	34,0 x 8 x 128,9	RA/S- Cr -	- 20° - -	1 - III	A 906 050 03 26 <b>160056</b>
	EX [2]	15,2 x 6 x 81,6	A - -	- 20° - -	9 -	A 906 050 06 26 A 906 050 07 26 A 906 016 07 91 <b>50 009 053 (1)</b>
	EX [2]	38,0 x 8 x 152,6	RA/S- Cr -	- 36° - VS -	1 - III	A 906 050 08 27 <b>16210</b>
	EX [2]	38,0 x 8 x 152,7	RA/S- Cr -	- 45° - -	1 - III	A 906 050 09 27 A 906 050 03 27 A 906 050 06 27 A 906 050 07 27 <b>160057</b>
	(1)	Konstantdrosselventil - flach Exhaust brake valve - flat Soupape de réduction permanente - plate Válvula de reducción permanente - plana Постоянный дроссельный клапан				
	[50]	Ø 8 mm				A 102 053 00 26 <b>RK-8H</b>
	IN/EX [4]	13,03 x 8 x 60,0	G2			A 906 053 01 29 <b>81-16105</b>
	IN/EX [4]	14,03 x 8 x 60,0	G2			A 906 053 01 30 A 906 053 05 29 <b>81-16107</b>
	IN [1]	35,08 x 28 x 7,6	G1			A 906 053 01 31 <b>92-16165 NEW</b>
	IN [1]	35,37 x 28 x 7,7	G1			A 906 053 02 31 <b>92-16159</b>
	EX [2]	40,38 x 31 x 8,5	G1 45°			A 906 053 02 32 A 906 053 14 32 <b>92-16160</b>
	EX [1]	40,08 x 31 x 8,0	G1			A 906 053 16 32 <b>92-16167 NEW</b>
	EX [1]	40,08 x 31.2 x 8,0	G1			A 906 053 01 32 A 906 053 12 32 <b>92-16166 NEW</b>
		817,5 mm				A 906 050 09 01 A 906 050 14 01 A 906 050 42 01 <b>20 1003 90600</b>
		818,5 mm				A 906 050 26 01 <b>20 1003 90601 NEW</b>
	[12]	M 33 x 18				A 906 054 07 01 A 906 054 10 01 <b>20 1003 90660</b>
		- - - -	- - - -	- EVB		A 906 010 59 21 A 906 010 72 21 <b>20 0803 90602</b>
<b>252</b>		<b>102</b>				
<b>OM 902 Euro 4</b>	<b>917 - 918, 924, 926 - 927, 930 - 934, 936</b>	D (LA) 6	6374 cm <sup>3</sup>	3V	175-210 kW (238-286 PS)	17,4:1 130,00 mm
	01.1998 →					
<b>OM 906 Euro 3</b>	<b>938</b>	D (LA) 6	6374 cm <sup>3</sup>	3V	205 kW (279 PS)	17,4:1 130,00 mm
<b>OM 906 Euro 2</b>	<b>911, 970</b>	D (LA) 6	6374 cm <sup>3</sup>	3V	194-209 kW (194-284 PS)	17,4:1 130,00 mm
	01.1998 →					
<b>OM 906 Euro 2</b>	<b>912</b>	D (A) 6	6374 cm <sup>3</sup>	3V	194 kW (264 PS)	17,4:1 130,00 mm
40 030 6.., 40 031 6.., 40 831 6.., 94 705 6.., 94 706 6.., 94 707 6.., 94 971 6..						
Fortsetzung nächste Seite / continued on next page / suite page suivante / continuación página próxima / Продолжение на следующей странице						



					Reference	Item No.	
	IN [2]	34,0 x 8 x 125,9	RA/S- Cr -	- 20° - -	1 - III	A 906 050 02 26	<b>16200</b>
	IN [2]	34,0 x 8 x 128,9	RA/S- Cr -	- 20° - -	1 - III	A 906 050 03 26 A 906 050 06 26 A 906 050 07 26	<b>160056</b>
EX [2]	EX [2]	15,2 x 6 x 81,6	A - -	- 20° - -	9 -	A 906 016 07 91	<b>50 009 053</b> (1)
	EX [2]	38,0 x 8 x 152,6	RA/S- Cr -	- 36° - VS -	1 - III	A 906 050 08 27 A 906 050 09 27	<b>16210</b>
EX [2]	38,0 x 8 x 152,7	RA/S- Cr -	- 45° - -	1 - III	A 906 050 03 27 A 906 050 06 27 A 906 050 07 27	<b>160057</b>	
(1) Konstantdrosselventil - flach Exhaust brake valve - flat Soupape de réduction permanente - plate Válvula de reducción permanente - plana Постоянный дроссельный клапан							
	[50]	Ø 8 mm				A 102 053 00 26	<b>RK-8H</b>
	IN/EX [4]	13,03 x 8 x 60,0	G2			A 906 053 01 29	<b>81-16105</b>
	IN/EX [4]	14,03 x 8 x 60,0	G2			A 906 053 01 30 A 906 053 05 29	<b>81-16107</b>
	IN [1]	35,08 x 28 x 7,6	G1			A 906 053 01 31	<b>92-16165</b> <small>NEW</small>
	IN [1]	35,37 x 28 x 7,7	G1			A 906 053 02 31	<b>92-16159</b>
	EX [2]	40,38 x 31 x 8,5	G1 45°			A 906 053 02 32 A 906 053 14 32	<b>92-16160</b>
	EX [1]	40,08 x 31 x 8,0	G1			A 906 053 16 32	<b>92-16167</b> <small>NEW</small>
	EX [1]	40,08 x 31.2 x 8,0	G1			A 906 053 01 32 A 906 053 12 32	<b>92-16166</b> <small>NEW</small>
		818,5 mm				A 906 050 26 01	<b>20 1003 90601</b> <small>NEW</small>
	[12]	M 33 x 18				A 906 054 07 01 A 906 054 10 01	<b>20 1003 90660</b>
		- - - -	- - - EVB			A 906 010 59 21 A 906 010 72 21	<b>20 0803 90602</b>

## 253

## 102

OM 906 Euro 2/3 **968**

D (LA) 6 6374 cm<sup>3</sup> 3V 172-187 kW (230-254 PS) 17,4-18 130,00 mm

OM 906 Euro 3 **991**

D (LA) 6 6374 cm<sup>3</sup> 3V 130-205 kW (177-279 PS) 18:1 130,00 mm

OM 906 Euro 2 **910**

01.1998 →

D (A) 6 6374 cm<sup>3</sup> 3V 170 kW (231 PS) 17,4:1 130,00 mm

OM 906 Euro 2 **929, 944, 946, 948, 957 - 958, 978 - 981**

D (LA) 6 6374 cm<sup>3</sup> 3V 142-224 kW (193-305 PS) 130,00 mm

40 031 6..., 94 705 6..., 94 706 6..., 94 707 6..., 94 931 6..., 94 932 6..., 94 933 6..., 94 971 6..

Fortsetzung nächste Seite / continued on next page / suite page suivante / continuación página próxima / Продолжение на следующей странице

					Reference	Item No.	
	IN [2]	34,0 x 8 x 125,9	RA/S- Cr -	- 20° - -	1 - III	A 906 050 02 26	<b>16200</b>
	IN [2]	34,0 x 8 x 128,9	RA/S- Cr -	- 20° - -	1 - III	A 906 050 03 26	<b>160056</b>
						A 906 050 06 26	
						A 906 050 07 26	
	EX [2]	15,2 x 6 x 81,6	A - -	- 20° - -	9 -	A 906 016 07 91	<b>50 009 053</b> (1)
EX [2]	38,0 x 8 x 152,6	RA/S- Cr -	- 36° - VS -	1 - III	A 906 050 08 27	<b>16210</b>	
					A 906 050 09 27		
EX [2]	38,0 x 8 x 152,7	RA/S- Cr -	- 45° - -	1 - III	A 906 050 03 27	<b>160057</b>	
					A 906 050 06 27		
					A 906 050 07 27		
(1) Konstantdrosselventil - flach Exhaust brake valve - flat Soupape de réduction permanente - plate Válvula de reducción permanente - plana Постоянный дроссельный клапан							
	[50]	Ø 8 mm			A 102 053 00 26	<b>RK-8H</b>	
	IN/EX [4]	13,03 x 8 x 60,0	G2		A 906 053 01 29	<b>81-16105</b>	
	IN/EX [4]	14,03 x 8 x 60,0	G2		A 906 053 01 30	<b>81-16107</b>	
					A 906 053 05 29		
	IN [1]	35,08 x 28 x 7,6	G1		A 906 053 01 31	<b>92-16165</b> <small>NEW</small>	
	IN [1]	35,37 x 28 x 7,7	G1		A 906 053 02 31	<b>92-16159</b>	
	EX [2]	40,38 x 31 x 8,5	G1 45°		A 906 053 02 32	<b>92-16160</b>	
					A 906 053 14 32		
EX [1]	40,08 x 31 x 8,0	G1			A 906 053 16 32	<b>92-16167</b> <small>NEW</small>	
		817,5 mm			A 906 050 09 01	<b>20 1003 90600</b>	
					A 906 050 14 01		
					A 906 050 42 01		
	[12]	M 33 x 18			A 906 054 07 01	<b>20 1003 90660</b>	
					A 906 054 10 01		
		- - - -	- - - EVB		A 906 010 59 21	<b>20 0803 90602</b>	
					A 906 010 72 21		

## 254 102

<b>OM 906 Euro 2/3</b>	<b>964 - 965</b>								
	2000 →	D (LA)	6	6374 cm <sup>3</sup>	3V	170-205 kW	(231-279 PS)	17,4-18	130,00 mm
<b>OM 906 Euro 3</b>	<b>928, 935, 939, 949 - 950, 952, 955, 961 - 962</b>								
	01.1998 →	D (LA)	6	6374 cm <sup>3</sup>	3V	170-205 kW	(231-279 PS)	17,4-18	130,00 mm
<b>OM 906 Euro 2/3</b>	<b>951</b>								
	03.1998 → 09.2006	D (A)	6	6374 cm <sup>3</sup>	3V	170 kW	(231 PS)	17,4-18	130,00 mm

94 705 6.., 94 706 6.., 94 707 6.., 94 931 6.., 94 932 6.., 94 933 6.., 94 971 6..

	IN [2]	34,0 x 8 x 125,9	RA/S- Cr -	- 20° - -	1 - III	A 906 050 02 26	<b>16200</b>
	IN [2]	34,0 x 8 x 128,9	RA/S- Cr -	- 20° - -	1 - III	A 906 050 03 26	<b>160056</b>
						A 906 050 06 26	
						A 906 050 07 26	
	EX [2]	15,2 x 6 x 81,6	A - -	- 20° - -	9 -	A 906 016 07 91	<b>50 009 053</b> (1)
EX [2]	38,0 x 8 x 152,6	RA/S- Cr -	- 36° - VS -	1 - III	A 906 050 08 27	<b>16210</b>	
					A 906 050 09 27		
EX [2]	38,0 x 8 x 152,7	RA/S- Cr -	- 45° - -	1 - III	A 906 050 03 27	<b>160057</b>	
					A 906 050 06 27		
					A 906 050 07 27		

Fortsetzung nächste Seite / continued on next page / suite page suivante / continuación página próxima / Продолжение на следующей странице

					Reference	Item No.
(1)	Konstantdrosselventil - flach Exhaust brake valve - flat Soupape de réduction permanente - plate Válvula de reducción permanente - plana Постоянный дроссельный клапан					
[50]	Ø 8 mm				A 102 053 00 26	<b>RK-8H</b>
IN/EX [4]	13,03 x 8 x 60,0	G2			A 906 053 01 29	<b>81-16105</b>
IN/EX [4]	14,03 x 8 x 60,0	G2			A 906 053 01 30 A 906 053 05 29	<b>81-16107</b>
IN [1]	35,08 x 28 x 7,6	G1			A 906 053 01 31	<b>92-16165</b> <small>NEW</small>
IN [1]	35,37 x 28 x 7,7	G1			A 906 053 02 31	<b>92-16159</b>
EX [2]	40,38 x 31 x 8,5	G1 45°			A 906 053 02 32 A 906 053 14 32	<b>92-16160</b>
EX [1]	40,08 x 31 x 8,0	G1			A 906 053 16 32	<b>92-16167</b> <small>NEW</small>
	817,5 mm				A 906 050 09 01 A 906 050 14 01 A 906 050 42 01	<b>20 1003 90600</b>
	818,5 mm				A 906 050 26 01	<b>20 1003 90601</b> <small>NEW</small>
[12]	M 33 x 18				A 906 054 07 01 A 906 054 10 01	<b>20 1003 90660</b>
	- - - -	- - - -	- - - - EVB		A 906 010 59 21 A 906 010 72 21	<b>20 0803 90602</b>

## 255 102

OM 906 Euro 2

931

01.1998 →

D (A)

6

6374 cm<sup>3</sup> 3V

170 kW

(231 PS) 17,4:1 130,00 mm

94 705 6..., 94 706 6..., 94 707 6..., 94 971 6..

IN [2]	34,0 x 8 x 125,9	RA/S- Cr -	- 20° - -	1 - III	A 906 050 02 26	<b>16200</b>
IN [2]	34,0 x 8 x 128,9	RA/S- Cr -	- 20° - -	1 - III	A 906 050 03 26 A 906 050 06 26 A 906 050 07 26	<b>160056</b>
EX [2]	15,2 x 6 x 81,6	A - -	- 20° - -	9 -	A 906 016 07 91	<b>50 009 053</b> (1)
EX [2]	38,0 x 8 x 152,6	RA/S- Cr -	- 36° - VS -	1 - III	A 906 050 08 27 A 906 050 09 27	<b>16210</b>
EX [2]	38,0 x 8 x 152,7	RA/S- Cr -	- 45° - -	1 - III	A 906 050 03 27 A 906 050 06 27 A 906 050 07 27	<b>160057</b>
(1)	Konstantdrosselventil - flach Exhaust brake valve - flat Soupape de réduction permanente - plate Válvula de reducción permanente - plana Постоянный дроссельный клапан					
[50]	Ø 8 mm				A 102 053 00 26	<b>RK-8H</b>
IN/EX [4]	13,03 x 8 x 60,0	G2			A 906 053 01 29	<b>81-16105</b>
IN/EX [4]	14,03 x 8 x 60,0	G2			A 906 053 01 30 A 906 053 05 29	<b>81-16107</b>
IN [1]	35,08 x 28 x 7,6	G1			A 906 053 01 31	<b>92-16165</b> <small>NEW</small>
IN [1]	35,37 x 28 x 7,7	G1			A 906 053 02 31	<b>92-16159</b>
EX [2]	40,38 x 31 x 8,5	G1 45°			A 906 053 02 32 A 906 053 14 32	<b>92-16160</b>

Fortsetzung nächste Seite / continued on next page / suite page suivante / continuación página próxima / Продолжение на следующей странице

					Reference	Item No.
	817,5 mm				A 906 050 09 01 A 906 050 14 01 A 906 050 42 01	<b>20 1003 90600</b>
[12]	M 33 x 18				A 906 054 07 01 A 906 054 10 01	<b>20 1003 90660</b>

## 256 102

**OM 909 Euro 2 900 - 901**  
01.1998 → D (LA) 6 6374 cm<sup>3</sup> 3V 170-205 kW (231-279 PS) 17,4:1 130,00 mm  
94 705 6.., 94 706 6.., 94 707 6.., 94 971 6..

	IN [2]	34,0 x 8 x 125,9	RA/S- Cr -	- 20° - -	1 - III	A 906 050 02 26	<b>16200</b>
	IN [2]	34,0 x 8 x 128,9	RA/S- Cr -	- 20° - -	1 - III	A 906 050 03 26 A 906 050 06 26 A 906 050 07 26	<b>160056</b>
	EX [2]	15,2 x 6 x 81,6	A - -	- 20° - -	9 -	A 906 016 07 91	<b>50 009 053</b> (1)
	EX [2]	38,0 x 8 x 152,6	RA/S- Cr -	- 36° - VS -	1 - III	A 906 050 08 27 A 906 050 09 27	<b>16210</b>
	EX [2]	38,0 x 8 x 152,7	RA/S- Cr -	- 45° - -	1 - III	A 906 050 03 27 A 906 050 06 27 A 906 050 07 27	<b>160057</b>
	(1) Konstantdrosselventil - flach Exhaust brake valve - flat Soupape de réduction permanente - plate Válvula de reducción permanente - plana Постоянный дроссельный клапан						

[50]	Ø 8 mm					A 102 053 00 26	<b>RK-8H</b>
------	--------	--	--	--	--	-----------------	--------------

	IN/EX [4]	13,03 x 8 x 60,0	G2			A 906 053 01 29	<b>81-16105</b>
	IN/EX [4]	14,03 x 8 x 60,0	G2			A 906 053 01 30 A 906 053 05 29	<b>81-16107</b>

	IN [1]	35,08 x 28 x 7,6	G1			A 906 053 01 31	<b>92-16165</b> <small>NEW</small>
	IN [1]	35,37 x 28 x 7,7	G1			A 906 053 02 31	<b>92-16159</b>
	EX [2]	40,38 x 31 x 8,5	G1 45°			A 906 053 02 32 A 906 053 14 32	<b>92-16160</b>
	EX [1]	40,08 x 31 x 8,0	G1			A 906 053 16 32	<b>92-16167</b> <small>NEW</small>

		817,5 mm				A 906 050 09 01 A 906 050 14 01 A 906 050 42 01	<b>20 1003 90600</b>
		818,5 mm				A 906 050 26 01	<b>20 1003 90601</b> <small>NEW</small>

[12]	M 33 x 18					A 906 054 07 01 A 906 054 10 01	<b>20 1003 90660</b>
------	-----------	--	--	--	--	------------------------------------	----------------------

## 257 102

**OM 906 Euro 3 963**  
04.1999 → D (LA) 6 6374 cm<sup>3</sup> 3V 180 kW (245 PS) 18:1 130,00 mm  
94 931 6.., 94 932 6.., 94 933 6..

	IN [2]	34,0 x 8 x 125,9	RA/S- Cr -	- 20° - -	1 - III	A 906 050 02 26	<b>16200</b>
	IN [2]	34,0 x 8 x 128,9	RA/S- Cr -	- 20° - -	1 - III	A 906 050 03 26 A 906 050 06 26 A 906 050 07 26	<b>160056</b>
	EX [2]	15,2 x 6 x 81,6	A - -	- 20° - -	9 -	A 906 016 07 91	<b>50 009 053</b> (1)
	EX [2]	38,0 x 8 x 152,6	RA/S- Cr -	- 36° - VS -	1 - III	A 906 050 08 27 A 906 050 09 27	<b>16210</b>
	EX [2]	38,0 x 8 x 152,7	RA/S- Cr -	- 45° - -	1 - III	A 906 050 03 27 A 906 050 06 27 A 906 050 07 27	<b>160057</b>

Fortsetzung nächste Seite / continued on next page / suite page suivante / continuación página próxima / Продолжение на следующей странице

					Reference	Item No.
(1)	Konstantdrosselventil - flach Exhaust brake valve - flat Soupape de réduction permanente - plate Válvula de reducción permanente - plana Постоянный дроссельный клапан					
[50]	Ø 8 mm				A 102 053 00 26	<b>RK-8H</b>
IN/EX [4]	13,03 x 8 x 60,0	G2			A 906 053 01 29	<b>81-16105</b>
IN/EX [4]	14,03 x 8 x 60,0	G2			A 906 053 01 30 A 906 053 05 29	<b>81-16107</b>
IN [1]	35,08 x 28 x 7,6	G1			A 906 053 01 31	<b>92-16165</b> <small>NEW</small>
IN [1]	35,37 x 28 x 7,7	G1			A 906 053 02 31	<b>92-16159</b>
EX [2]	40,38 x 31 x 8,5	G1 45°			A 906 053 02 32 A 906 053 14 32	<b>92-16160</b>
EX [1]	40,08 x 31 x 8,0	G1			A 906 053 16 32	<b>92-16167</b> <small>NEW</small>
	817,5 mm				A 906 050 09 01 A 906 050 14 01 A 906 050 42 01	<b>20 1003 90600</b>
[12]	M 33 x 18				A 906 054 07 01 A 906 054 10 01	<b>20 1003 90660</b>

**258** **102**
**OM 906 Euro 2/3 982**

 05.1999 → 11.2011 D (LA) 6 6374 cm<sup>3</sup> 3V

170 kW

(231 PS) 17,4-18 130,00 mm

94 705 6.., 94 706 6.., 94 707 6.., 94 931 6.., 94 932 6.., 94 933 6.., 94 971 6..

IN [2]	34,0 x 8 x 125,9	RA/S- Cr -	- 20° - -	1 - III	A 906 050 02 26	<b>16200</b>
IN [2]	34,0 x 8 x 128,9	RA/S- Cr -	- 20° - -	1 - III	A 906 050 03 26 A 906 050 06 26 A 906 050 07 26	<b>160056</b>
EX [2]	15,2 x 6 x 81,6	A - -	- 20° - -	9 -	A 906 016 07 91	<b>50 009 053</b> (1)
EX [2]	38,0 x 8 x 152,6	RA/S- Cr -	- 36° - VS -	1 - III	A 906 050 08 27 A 906 050 09 27	<b>16210</b>
EX [2]	38,0 x 8 x 152,7	RA/S- Cr -	- 45° - -	1 - III	A 906 050 03 27 A 906 050 06 27 A 906 050 07 27	<b>160057</b>
(1)	Konstantdrosselventil - flach Exhaust brake valve - flat Soupape de réduction permanente - plate Válvula de reducción permanente - plana Постоянный дроссельный клапан					
[50]	Ø 8 mm				A 102 053 00 26	<b>RK-8H</b>
IN/EX [4]	13,03 x 8 x 60,0	G2			A 906 053 01 29	<b>81-16105</b>
IN/EX [4]	14,03 x 8 x 60,0	G2			A 906 053 01 30 A 906 053 05 29	<b>81-16107</b>
IN [1]	35,08 x 28 x 7,6	G1			A 906 053 01 31	<b>92-16165</b> <small>NEW</small>
IN [1]	35,37 x 28 x 7,7	G1			A 906 053 02 31	<b>92-16159</b>
EX [2]	40,38 x 31 x 8,5	G1 45°			A 906 053 02 32 A 906 053 14 32	<b>92-16160</b>
EX [1]	40,08 x 31 x 8,0	G1			A 906 053 16 32	<b>92-16167</b> <small>NEW</small>
[12]	M 33 x 18				A 906 054 07 01 A 906 054 10 01	<b>20 1003 90660</b>

Fortsetzung nächste Seite / continued on next page / suite page suivante / continuación página próxima / Продолжение на следующей странице



					Reference	Item No.
	- - - -	- - - EVB			A 906 010 59 21 A 906 010 72 21	20 0803 90602

## 259 102

<b>OM 906 Euro 2</b>	<b>974, 977</b>	D (LA)	6	6374 cm <sup>3</sup>	3V	209 kW	(280 PS)	17,4:1	130,00 mm
<b>OM 906 Euro 3</b>	<b>983</b>	D (LA)	6	6374 cm <sup>3</sup>	3V	180 kW	(245 PS)	17,4-18	130,00 mm
01.2000 →									
94 705 6.., 94 706 6.., 94 707 6.., 94 931 6.., 94 932 6.., 94 933 6.., 94 971 6..									

	IN [2]	34,0 x 8 x 125,9	RA/S- Cr -	- 20° - -	1 - III	A 906 050 02 26	<b>16200</b>
	IN [2]	34,0 x 8 x 128,9	RA/S- Cr -	- 20° - -	1 - III	A 906 050 03 26 A 906 050 06 26 A 906 050 07 26	<b>160056</b>
	EX [2]	15,2 x 6 x 81,6	A - -	- 20° - -	9 -	A 906 016 07 91	<b>50 009 053</b> (1)
	EX [2]	38,0 x 8 x 152,6	RA/S- Cr -	- 36° - VS -	1 - III	A 906 050 08 27 A 906 050 09 27	<b>16210</b>
	EX [2]	38,0 x 8 x 152,7	RA/S- Cr -	- 45° - -	1 - III	A 906 050 03 27 A 906 050 06 27 A 906 050 07 27	<b>160057</b>
	(1) Konstantdrosselventil - flach Exhaust brake valve - flat Soupape de réduction permanente - plate Válvula de reducción permanente - plana Постоянный дроссельный клапан						
	[50]	Ø 8 mm				A 102 053 00 26	<b>RK-8H</b>
	IN/EX [4]	13,03 x 8 x 60,0	G2			A 906 053 01 29	<b>81-16105</b>
	IN/EX [4]	14,03 x 8 x 60,0	G2			A 906 053 01 30 A 906 053 05 29	<b>81-16107</b>
	IN [1]	35,08 x 28 x 7,6	G1			A 906 053 01 31	<b>92-16165</b> <small>NEW</small>
	IN [1]	35,37 x 28 x 7,7	G1			A 906 053 02 31	<b>92-16159</b>
	EX [2]	40,38 x 31 x 8,5	G1 45°			A 906 053 02 32 A 906 053 14 32	<b>92-16160</b>
	EX [1]	40,08 x 31.2 x 8,0	G1			A 906 053 01 32 A 906 053 12 32	<b>92-16166</b> <small>NEW</small>
		817,5 mm				A 906 050 09 01 A 906 050 14 01 A 906 050 42 01	<b>20 1003 90600</b>
	[12]	M 33 x 18				A 906 054 07 01 A 906 054 10 01	<b>20 1003 90660</b>
	- - - -	- - - EVB				A 906 010 59 21 A 906 010 72 21	20 0803 90602

## 260 102

<b>OM 906 Euro 2</b>	<b>967, 976</b>	D (LA)	6	6374 cm <sup>3</sup>	3V	209 kW	(284 PS)	17,4:1	130,00 mm
10.2000 →									
94 705 6.., 94 706 6.., 94 707 6.., 94 971 6..									

Fortsetzung nächste Seite / continued on next page / suite page suivante / continuación página próxima / Продолжение на следующей странице

					Reference	Item No.
	IN [2] 34,0 x 8 x 125,9	RA/S- Cr -	- 20° - -	1 - III	A 906 050 02 26	<b>16200</b>
	IN [2] 34,0 x 8 x 128,9	RA/S- Cr -	- 20° - -	1 - III	A 906 050 03 26 A 906 050 06 26 A 906 050 07 26	<b>160056</b>
	EX [2] 15,2 x 6 x 81,6	A - -	- 20° - -	9 -	A 906 016 07 91	<b>50 009 053</b> (1)
	EX [2] 38,0 x 8 x 152,6	RA/S- Cr -	- 36° - VS -	1 - III	A 906 050 08 27 A 906 050 09 27	<b>16210</b>
	EX [2] 38,0 x 8 x 152,7	RA/S- Cr -	- 45° - -	1 - III	A 906 050 03 27 A 906 050 06 27 A 906 050 07 27	<b>160057</b>
	(1) Konstantdrosselventil - flach Exhaust brake valve - flat Soupape de réduction permanente - plate Válvula de reducción permanente - plana Постоянный дроссельный клапан					
	[50] Ø 8 mm				A 102 053 00 26	<b>RK-8H</b>
	IN/EX [4] 13,03 x 8 x 60,0	G2			A 906 053 01 29	<b>81-16105</b>
	IN/EX [4] 14,03 x 8 x 60,0	G2			A 906 053 01 30 A 906 053 05 29	<b>81-16107</b>
	IN [1] 35,08 x 28 x 7,6	G1			A 906 053 01 31	<b>92-16165</b> <small>NEW</small>
	IN [1] 35,37 x 28 x 7,7	G1			A 906 053 02 31	<b>92-16159</b>
	EX [2] 40,38 x 31 x 8,5	G1 45°			A 906 053 02 32 A 906 053 14 32	<b>92-16160</b>
	EX [1] 40,08 x 31.2 x 8,0	G1			A 906 053 01 32 A 906 053 12 32	<b>92-16166</b> <small>NEW</small>
	818,5 mm				A 906 050 26 01	<b>20 1003 90601</b> <small>NEW</small>
	[12] M 33 x 18				A 906 054 07 01 A 906 054 10 01	<b>20 1003 90660</b>
	- - - -	- - - -	- EVB		A 906 010 59 21 A 906 010 72 21	<b>20 0803 90602</b>

## 261 102

OM 906 Euro 2 975

D (LA) 6 6374 cm<sup>3</sup> 3V 180 kW (245 PS) 17,4:1 130,00 mm

94 705 6..., 94 706 6..., 94 707 6..., 94 971 6..

	IN [2] 34,0 x 8 x 125,9	RA/S- Cr -	- 20° - -	1 - III	A 906 050 02 26	<b>16200</b>
	IN [2] 34,0 x 8 x 128,9	RA/S- Cr -	- 20° - -	1 - III	A 906 050 03 26 A 906 050 06 26 A 906 050 07 26	<b>160056</b>
	EX [2] 15,2 x 6 x 81,6	A - -	- 20° - -	9 -	A 906 016 07 91	<b>50 009 053</b> (1)
	EX [2] 38,0 x 8 x 152,6	RA/S- Cr -	- 36° - VS -	1 - III	A 906 050 08 27 A 906 050 09 27	<b>16210</b>
	EX [2] 38,0 x 8 x 152,7	RA/S- Cr -	- 45° - -	1 - III	A 906 050 03 27 A 906 050 06 27 A 906 050 07 27	<b>160057</b>
	(1) Konstantdrosselventil - flach Exhaust brake valve - flat Soupape de réduction permanente - plate Válvula de reducción permanente - plana Постоянный дроссельный клапан					

Fortsetzung nächste Seite / continued on next page / suite page suivante / continuación página próxima / Продолжение на следующей странице

					Reference	Item No.
[50]	Ø 8 mm				A 102 053 00 26	<b>RK-8H</b>
IN/EX [4]	13,03 x 8 x 60,0	G2			A 906 053 01 29	<b>81-16105</b>
IN/EX [4]	14,03 x 8 x 60,0	G2			A 906 053 01 30	<b>81-16107</b>
					A 906 053 05 29	
IN [1]	35,08 x 28 x 7,6	G1			A 906 053 01 31	<b>92-16165</b> <small>NEW</small>
IN [1]	35,37 x 28 x 7,7	G1			A 906 053 02 31	<b>92-16159</b>
EX [2]	40,38 x 31 x 8,5	G1 45°			A 906 053 02 32	<b>92-16160</b>
					A 906 053 14 32	
EX [1]	40,08 x 31.2 x 8,0	G1			A 906 053 01 32	<b>92-16166</b> <small>NEW</small>
					A 906 053 12 32	
	817,5 mm				A 906 050 09 01	<b>20 1003 90600</b>
					A 906 050 14 01	
					A 906 050 42 01	
[12]	M 33 x 18				A 906 054 07 01	<b>20 1003 90660</b>
					A 906 054 10 01	

## 262 102

**OM 904 Euro 3 960**  
 11.2001 → D (LA) 4 4250 cm<sup>3</sup> 3V 100 kW (136 PS) 18:1 130,00 mm  
 94 931 6.., 94 932 6.., 94 933 6..

IN [2]	34,0 x 8 x 125,9	RA/S- Cr -	- 20° - -	1 - III	A 906 050 02 26	<b>16200</b>
IN [2]	34,0 x 8 x 128,9	RA/S- Cr -	- 20° - -	1 - III	A 906 050 03 26	<b>160056</b>
					A 906 050 06 26	
					A 906 050 07 26	
EX [2]	15,2 x 6 x 81,6	A - -	- 20° - -	9 -	A 906 016 07 91	<b>50 009 053</b> (1)
EX [2]	38,0 x 8 x 152,6	RA/S- Cr -	- 36° - VS -	1 - III	A 906 050 08 27	<b>16210</b>
					A 906 050 09 27	
EX [2]	38,0 x 8 x 152,7	RA/S- Cr -	- 45° - -	1 - III	A 906 050 03 27	<b>160057</b>
					A 906 050 06 27	
					A 906 050 07 27	
	(1) Konstantdrosselventil - flach Exhaust brake valve - flat Soupape de réduction permanente - plate Válvula de reducción permanente - plana Постоянный дроссельный клапан					

[50]	Ø 8 mm				A 102 053 00 26	<b>RK-8H</b>
IN/EX [4]	13,03 x 8 x 60,0	G2			A 906 053 01 29	<b>81-16105</b>
IN/EX [4]	14,03 x 8 x 60,0	G2			A 906 053 01 30	<b>81-16107</b>
					A 906 053 05 29	
IN [1]	35,08 x 28 x 7,6	G1			A 906 053 01 31	<b>92-16165</b> <small>NEW</small>
IN [1]	35,37 x 28 x 7,7	G1			A 906 053 02 31	<b>92-16159</b>
EX [2]	40,38 x 31 x 8,5	G1 45°			A 906 053 02 32	<b>92-16160</b>
					A 906 053 14 32	
					A 904 050 04 01	<b>20 1003 90400</b>
					A 904 050 09 01	
					A 904 050 40 01	

## 263 102

**OM 904 Euro 3 958, 969**  
 03.2002 → D (LA) 4 4250 cm<sup>3</sup> 3V 100-130 kW (136-177 PS) 18:1 130,00 mm

**OM 906 Euro 3 987, 989**  
 03.2002 → D (LA) 6 6374 cm<sup>3</sup> 3V 100-170 kW (136-231 PS) 18:1 130,00 mm

94 931 6.., 94 932 6.., 94 933 6..

Fortsetzung nächste Seite / continued on next page / suite page suivante / continuación página próxima / Продолжение на следующей странице

					Reference	Item No.	
	IN [2]	34,0 x 8 x 125,9	RA/S- Cr -	- 20° - -	1 - III	A 906 050 02 26	<b>16200</b>
	IN [2]	34,0 x 8 x 128,9	RA/S- Cr -	- 20° - -	1 - III	A 906 050 03 26 A 906 050 06 26 A 906 050 07 26	<b>160056</b>
	EX [2]	38,0 x 8 x 152,6	RA/S- Cr -	- 36° - VS -	1 - III	A 906 050 08 27 A 906 050 09 27	<b>16210</b>
	EX [2]	38,0 x 8 x 152,7	RA/S- Cr -	- 45° - -	1 - III	A 906 050 03 27 A 906 050 06 27 A 906 050 07 27	<b>160057</b>
	[50]	Ø 8 mm				A 102 053 00 26	<b>RK-8H</b>
	IN/EX [4]	13,03 x 8 x 60,0	G2			A 906 053 01 29	<b>81-16105</b>
	IN/EX [4]	14,03 x 8 x 60,0	G2			A 906 053 01 30 A 906 053 05 29	<b>81-16107</b>
	IN [1]	35,37 x 28 x 7,7	G1			A 906 053 02 31	<b>92-16159</b>
	EX [2]	40,38 x 31 x 8,5	G1 45°			A 906 053 02 32 A 906 053 14 32	<b>92-16160</b>

## 264

OM 904 Euro 3

965

05.2003 →

D (LA) 4 4249 cm<sup>3</sup> 3V 110 kW (150 PS) 17,4:1 130,00 mm

94 705 6..., 94 706 6..., 94 707 6..., 94 971 6..

	IN [2]	34,0 x 8 x 125,9	RA/S- Cr -	- 20° - -	1 - III	A 906 050 02 26	<b>16200</b>
	IN [2]	34,0 x 8 x 128,9	RA/S- Cr -	- 20° - -	1 - III	A 906 050 03 26 A 906 050 06 26 A 906 050 07 26	<b>160056</b>
	EX [2]	15,2 x 6 x 81,6	A - -	- 20° - -	9 -	A 906 016 07 91	<b>50 009 053</b> (1)
	EX [2]	38,0 x 8 x 152,6	RA/S- Cr -	- 36° - VS -	1 - III	A 906 050 08 27 A 906 050 09 27	<b>16210</b>
	EX [2]	38,0 x 8 x 152,7	RA/S- Cr -	- 45° - -	1 - III	A 906 050 03 27 A 906 050 06 27 A 906 050 07 27	<b>160057</b>
	(1) Konstantdrosselventil - flach Exhaust brake valve - flat Soupape de réduction permanente - plate Válvula de reducción permanente - plana Постоянный дроссельный клапан						
	[50]	Ø 8 mm				A 102 053 00 26	<b>RK-8H</b>
	IN/EX [4]	13,03 x 8 x 60,0	G2			A 906 053 01 29	<b>81-16105</b>
	IN/EX [4]	14,03 x 8 x 60,0	G2			A 906 053 01 30 A 906 053 05 29	<b>81-16107</b>
	IN [1]	35,08 x 28 x 7,6	G1			A 906 053 01 31	<b>92-16165</b> <small>NEW</small>
	IN [1]	35,37 x 28 x 7,7	G1			A 906 053 02 31	<b>92-16159</b>
	EX [2]	40,38 x 31 x 8,5	G1 45°			A 906 053 02 32 A 906 053 14 32	<b>92-16160</b>
	EX [1]	40,08 x 31.2 x 8,0	G1			A 906 053 01 32 A 906 053 12 32	<b>92-16166</b> <small>NEW</small>
	[12]	M 33 x 18				A 906 054 07 01 A 906 054 10 01	<b>20 1003 90660</b>

## 265

OM 906 Euro 3

986

10.2004 →

D (LA) 6 6374 cm<sup>3</sup> 3V 205 kW (279 PS) 17,4:1 130,00 mm

OM 906 Euro 3

973

D (LA) 6 6374 cm<sup>3</sup> 4V 170 kW (231 PS) 17,4:1 130,00 mm

94 705 6..., 94 706 6..., 94 707 6..., 94 971 6..

Fortsetzung nächste Seite / continued on next page / suite page suivante / continuación página próxima / Продолжение на следующей странице

					Reference	Item No.	
	IN [2]	34,0 x 8 x 125,9	RA/S- Cr -	- 20° - -	1 - III	A 906 050 02 26	<b>16200</b>
	IN [2]	34,0 x 8 x 128,9	RA/S- Cr -	- 20° - -	1 - III	A 906 050 03 26	<b>160056</b>
						A 906 050 06 26	
						A 906 050 07 26	
	EX [2]	15,2 x 6 x 81,6	A - -	- 20° - -	9 -	A 906 016 07 91	<b>50 009 053</b> (1)
EX [2]	38,0 x 8 x 152,6	RA/S- Cr -	- 36° - VS -	1 - III	A 906 050 08 27	<b>16210</b>	
					A 906 050 09 27		
EX [2]	38,0 x 8 x 152,7	RA/S- Cr -	- 45° - -	1 - III	A 906 050 03 27	<b>160057</b>	
					A 906 050 06 27		
					A 906 050 07 27		
(1) Konstantdrosselventil - flach Exhaust brake valve - flat Soupape de réduction permanente - plate Válvula de reducción permanente - plana Постоянный дроссельный клапан							
	[50]	Ø 8 mm			A 102 053 00 26	<b>RK-8H</b>	
	IN [1]	35,08 x 28 x 7,6	G1		A 906 053 01 31	<b>92-16165</b> <small>NEW</small>	
	EX [1]	40,08 x 31 x 8,0	G1		A 906 053 16 32	<b>92-16167</b> <small>NEW</small>	
	EX [1]	40,08 x 31.2 x 8,0	G1		A 906 053 01 32	<b>92-16166</b> <small>NEW</small>	
					A 906 053 12 32		
		817,5 mm			A 906 050 09 01	<b>20 1003 90600</b>	
					A 906 050 14 01		
					A 906 050 42 01		
	[12]	M 33 x 18			A 906 054 07 01	<b>20 1003 90660</b>	
					A 906 054 10 01		
		- - - -	- - - EVB		A 906 010 59 21	<b>20 0803 90602</b>	
					A 906 010 72 21		

## 266 102

**OM 906 Euro 3 990, 992 - 995, 998**

D (LA) 6 6374 cm<sup>3</sup> 3V 180-206 kW (245-279 PS) 130,00 mm  
94 705 6.., 94 706 6.., 94 707 6.., 94 931 6.., 94 932 6.., 94 933 6.., 94 971 6..

	IN [2]	34,0 x 8 x 125,9	RA/S- Cr -	- 20° - -	1 - III	A 906 050 02 26	<b>16200</b>
	IN [2]	34,0 x 8 x 128,9	RA/S- Cr -	- 20° - -	1 - III	A 906 050 03 26	<b>160056</b>
						A 906 050 06 26	
						A 906 050 07 26	
	EX [2]	38,0 x 8 x 152,6	RA/S- Cr -	- 36° - VS -	1 - III	A 906 050 08 27	<b>16210</b>
					A 906 050 09 27		
EX [2]	38,0 x 8 x 152,7	RA/S- Cr -	- 45° - -	1 - III	A 906 050 03 27	<b>160057</b>	
					A 906 050 06 27		
					A 906 050 07 27		
	[50]	Ø 8 mm			A 102 053 00 26	<b>RK-8H</b>	
	IN/EX [4]	13,03 x 8 x 60,0	G2		A 906 053 01 29	<b>81-16105</b>	
	IN/EX [4]	14,03 x 8 x 60,0	G2		A 906 053 01 30	<b>81-16107</b>	
					A 906 053 05 29		

Fortsetzung nächste Seite / continued on next page / suite page suivante / continuación página próxima / Продолжение на следующей странице



					Reference	Item No.
	IN [1]	35,08 x 28 x 7,6	G1		A 906 053 01 31	<b>92-16165</b> <small>NEW</small>
	IN [1]	35,37 x 28 x 7,7	G1		A 906 053 02 31	<b>92-16159</b>
	EX [2]	40,38 x 31 x 8,5	G1 45°		A 906 053 02 32	<b>92-16160</b>
	EX [1]	40,08 x 31 x 8,0	G1		A 906 053 14 32	
	EX [1]	40,08 x 31.2 x 8,0	G1		A 906 053 16 32	<b>92-16167</b> <small>NEW</small>
					A 906 053 01 32	<b>92-16166</b> <small>NEW</small>
					A 906 053 12 32	
	817,5 mm				A 906 050 09 01	<b>20 1003 90600</b>
					A 906 050 14 01	
					A 906 050 42 01	
	[12] M 33 x 18				A 906 054 07 01	<b>20 1003 90660</b>
					A 906 054 10 01	
	- - - -	- - - - EVB			A 906 010 59 21	<b>20 0803 90602</b>
					A 906 010 72 21	

**267** **102**
**OM 902 Euro 4**
**922**

D (LA) 6 6374 cm<sup>3</sup> 3V 142 kW (190 PS) 130,00 mm

	IN [2]	34,0 x 8 x 125,9	RA/S- Cr -	- 20° - -	1 - III	A 906 050 02 26	<b>16200</b>
	IN [2]	34,0 x 8 x 128,9	RA/S- Cr -	- 20° - -	1 - III	A 906 050 03 26	<b>160056</b>
						A 906 050 06 26	
						A 906 050 07 26	
	EX [2]	15,2 x 6 x 81,6	A - -	- 20° - -	9 -	A 906 016 07 91	<b>50 009 053</b> (1)
	EX [2]	38,0 x 8 x 152,6	RA/S- Cr -	- 36° - VS -	1 - III	A 906 050 08 27	<b>16210</b>
						A 906 050 09 27	
	EX [2]	38,0 x 8 x 152,7	RA/S- Cr -	- 45° - -	1 - III	A 906 050 03 27	<b>160057</b>
						A 906 050 06 27	
						A 906 050 07 27	
	(1) Konstantdrosselventil - flach Exhaust brake valve - flat Soupape de réduction permanente - plate Válvula de reducción permanente - plana Постоянный дроссельный клапан						
	[50] Ø 8 mm					A 102 053 00 26	<b>RK-8H</b>
	IN/EX [4]	13,03 x 8 x 60,0	G2			A 906 053 01 29	<b>81-16105</b>
	IN/EX [4]	14,03 x 8 x 60,0	G2			A 906 053 01 30	<b>81-16107</b>
						A 906 053 05 29	
	IN [1]	35,08 x 28 x 7,6	G1			A 906 053 01 31	<b>92-16165</b> <small>NEW</small>
	IN [1]	35,37 x 28 x 7,7	G1			A 906 053 02 31	<b>92-16159</b>
	EX [2]	40,38 x 31 x 8,5	G1 45°			A 906 053 02 32	<b>92-16160</b>
						A 906 053 14 32	
	EX [1]	40,08 x 31 x 8,0	G1			A 906 053 16 32	<b>92-16167</b> <small>NEW</small>
EX [1]	40,08 x 31.2 x 8,0	G1			A 906 053 01 32	<b>92-16166</b> <small>NEW</small>	
					A 906 053 12 32		
	817,5 mm					A 906 050 09 01	<b>20 1003 90600</b>
						A 906 050 14 01	
						A 906 050 42 01	
						A 906 050 32 01	<b>20 1003 90605</b>
						A 906 050 40 01	
	[12] M 33 x 18					A 906 054 07 01	<b>20 1003 90660</b>
						A 906 054 10 01	

Fortsetzung nächste Seite / continued on next page / suite page suivante / continuación página próxima / Продолжение на следующей странице

					Reference	Item No.
	- - - -	- - - EVB			A 906 010 59 21 A 906 010 72 21	20 0803 90602

## 268 102

OM 902 Euro 3 935

D (LA) 6 6374 cm<sup>3</sup> 3V 170-205 kW (231-279 PS) 18:1 130,00 mm

94 931 6.., 94 932 6.., 94 933 6..

	IN [2] IN [2]	34,0 x 8 x 125,9 34,0 x 8 x 128,9	RA/S- Cr - RA/S- Cr -	- 20° - - - 20° - -	1 - III 1 - III	A 906 050 02 26 A 906 050 03 26 A 906 050 06 26 A 906 050 07 26	16200 160056
	EX [2]	38,0 x 8 x 152,6	RA/S- Cr -	- 36° - VS -	1 - III	A 906 050 08 27 A 906 050 09 27	16210
	EX [2]	38,0 x 8 x 152,7	RA/S- Cr -	- 45° - -	1 - III	A 906 050 03 27 A 906 050 06 27 A 906 050 07 27	160057
	[50]	Ø 8 mm				A 102 053 00 26	RK-8H
	IN/EX [4] IN/EX [4]	13,03 x 8 x 60,0 14,03 x 8 x 60,0	G2 G2			A 906 053 01 29 A 906 053 01 30 A 906 053 05 29	81-16105 81-16107
	IN [1] IN [1] EX [2]	35,08 x 28 x 7,6 35,37 x 28 x 7,7 40,38 x 31 x 8,5	G1 G1 G1 45°			A 906 053 01 31 A 906 053 02 31 A 906 053 02 32 A 906 053 14 32	92-16165 <b>NEW</b> 92-16159 92-16160
	EX [1]	40,08 x 31 x 8,0	G1			A 906 053 16 32	92-16167 <b>NEW</b>
		817,5 mm				A 906 050 09 01 A 906 050 14 01 A 906 050 42 01	20 1003 90600
		818,5 mm				A 906 050 26 01	20 1003 90601 <b>NEW</b>
	[12]	M 33 x 18				A 906 054 07 01 A 906 054 10 01	20 1003 90660
	- - - -	- - - EVB				A 906 010 59 21 A 906 010 72 21	20 0803 90602

## 269 102

OM 902 Euro 3 937

D (LA) 6 6374 cm<sup>3</sup> 3V 180 kW (245 PS) 130,00 mm

94 705 6.., 94 706 6.., 94 707 6.., 94 971 6..

	IN/EX [4] IN/EX [4]	13,03 x 8 x 60,0 14,03 x 8 x 60,0	G2 G2			A 906 053 01 29 A 906 053 01 30 A 906 053 05 29	81-16105 81-16107
--	------------------------	--------------------------------------	----------	--	--	---	----------------------

Fortsetzung nächste Seite / continued on next page / suite page suivante / continuación página próxima / Продолжение на следующей странице

					Reference	Item No.
IN [1]	35,08 x 28 x 7,6	G1			A 906 053 01 31	<b>92-16165</b> <small>NEW</small>
IN [1]	35,37 x 28 x 7,7	G1			A 906 053 02 31	<b>92-16159</b>
EX [2]	40,38 x 31 x 8,5	G1 45°			A 906 053 02 32	<b>92-16160</b>
EX [1]	40,08 x 31 x 8,0	G1			A 906 053 14 32	
EX [1]	40,08 x 31.2 x 8,0	G1			A 906 053 16 32	<b>92-16167</b> <small>NEW</small>
					A 906 053 01 32	<b>92-16166</b> <small>NEW</small>
					A 906 053 12 32	
	817,5 mm				A 906 050 09 01	<b>20 1003 90600</b>
					A 906 050 14 01	
					A 906 050 42 01	
	818,5 mm				A 906 050 26 01	<b>20 1003 90601</b> <small>NEW</small>
[12]	M 33 x 18				A 906 054 07 01	<b>20 1003 90660</b>
					A 906 054 10 01	
	- - - -	- - - EVB			A 906 010 59 21	<b>20 0803 90602</b>
					A 906 010 72 21	

M

**270** **102**

**OM 902 Euro 3 938** D (LA) 6 6374 cm<sup>3</sup> 3V 191 kW (260 PS) 130,00 mm  
 94 705 6..., 94 706 6..., 94 707 6..., 94 971 6..

	817,5 mm				A 906 050 09 01	<b>20 1003 90600</b>
					A 906 050 14 01	
					A 906 050 42 01	
	818,5 mm				A 906 050 26 01	<b>20 1003 90601</b> <small>NEW</small>
[12]	M 33 x 18				A 906 054 07 01	<b>20 1003 90660</b>
					A 906 054 10 01	
	- - - -	- - - EVB			A 906 010 59 21	<b>20 0803 90602</b>
					A 906 010 72 21	

**271** **102**

**OM 902 Euro 3 939** D (LA) 6 6374 cm<sup>3</sup> 3V 191 kW (260 PS) 130,00 mm  
 94 705 6..., 94 706 6..., 94 707 6..., 94 971 6..

IN [1]	35,08 x 28 x 7,6	G1			A 906 053 01 31	<b>92-16165</b> <small>NEW</small>
EX [1]	40,08 x 31 x 8,0	G1			A 906 053 16 32	<b>92-16167</b> <small>NEW</small>
EX [1]	40,08 x 31.2 x 8,0	G1			A 906 053 01 32	<b>92-16166</b> <small>NEW</small>
					A 906 053 12 32	
	817,5 mm				A 906 050 09 01	<b>20 1003 90600</b>
					A 906 050 14 01	
					A 906 050 42 01	
	818,5 mm				A 906 050 26 01	<b>20 1003 90601</b> <small>NEW</small>
[12]	M 33 x 18				A 906 054 07 01	<b>20 1003 90660</b>
					A 906 054 10 01	

Fortsetzung nächste Seite / continued on next page / suite page suivante / continuación página próxima / Продолжение на следующей странице

					Reference	Item No.
	- - - -	- - - EVB			A 906 010 59 21 A 906 010 72 21	20 0803 90602

## 272 102

OM 902 Euro 3 970 - 972

D (LA) 6 6374 cm<sup>3</sup> 3V 130-205 kW (177-279 PS) 130,00 mm

94 931 6.., 94 932 6.., 94 933 6..

	IN [2]	34,0 x 8 x 125,9	RA/S- Cr -	- 20° - -	1 - III	A 906 050 02 26	16200
	IN [2]	34,0 x 8 x 128,9	RA/S- Cr -	- 20° - -	1 - III	A 906 050 03 26 A 906 050 06 26 A 906 050 07 26	160056
	EX [2]	38,0 x 8 x 152,6	RA/S- Cr -	- 36° - VS -	1 - III	A 906 050 08 27	16210
	EX [2]	38,0 x 8 x 152,7	RA/S- Cr -	- 45° - -	1 - III	A 906 050 09 27 A 906 050 03 27 A 906 050 06 27 A 906 050 07 27	160057
	[50]	Ø 8 mm				A 102 053 00 26	RK-8H
	IN/EX [4]	14,03 x 8 x 60,0	G2			A 906 053 01 30 A 906 053 05 29	81-16107
	IN [1]	35,08 x 28 x 7,6	G1			A 906 053 01 31	92-16165 <b>NEW</b>
	IN [1]	35,37 x 28 x 7,7	G1			A 906 053 02 31	92-16159
	EX [2]	40,38 x 31 x 8,5	G1 45°			A 906 053 02 32 A 906 053 14 32	92-16160
	EX [1]	40,08 x 31 x 8,0	G1			A 906 053 16 32	92-16167 <b>NEW</b>
		817,5 mm				A 906 050 09 01 A 906 050 14 01 A 906 050 42 01	20 1003 90600
	[12]	M 33 x 18				A 906 054 07 01 A 906 054 10 01	20 1003 90660

## 273 102

OM 904 Euro 2 977 - 978, 981

D (LA) 4 4249 cm<sup>3</sup> 3V 110-130 kW (150-177 PS) 17,4:1 130,00 mm

94 705 6.., 94 706 6.., 94 707 6.., 94 971 6..

	IN/EX [4]	13,03 x 8 x 60,0	G2			A 906 053 01 29	81-16105
	IN/EX [4]	14,03 x 8 x 60,0	G2			A 906 053 01 30 A 906 053 05 29	81-16107
	IN [1]	35,08 x 28 x 7,6	G1			A 906 053 01 31	92-16165 <b>NEW</b>
	IN [1]	35,37 x 28 x 7,7	G1			A 906 053 02 31	92-16159
	EX [2]	40,38 x 31 x 8,5	G1 45°			A 906 053 02 32 A 906 053 14 32	92-16160
	EX [1]	40,08 x 31 x 8,0	G1			A 906 053 16 32	92-16167 <b>NEW</b>
	EX [1]	40,08 x 31.2 x 8,0	G1			A 906 053 01 32 A 906 053 12 32	92-16166 <b>NEW</b>
						A 904 050 04 01 A 904 050 09 01 A 904 050 40 01	20 1003 90400
	[12]	M 33 x 18				A 906 054 07 01 A 906 054 10 01	20 1003 90660

					Reference	Item No.	
<b>274</b>		<b>102</b>					
<b>OM 904</b>	<b>985 - 986</b>						
94 931 6..., 94 932 6..., 94 933 6..							
		D (LA)	4	4249 cm <sup>3</sup>	3V	113-130 kW (154-177 PS) 17,4	130,00 mm
					A 904 050 04 01 A 904 050 09 01 A 904 050 40 01	<b>20 1003 90400</b>	
	[12]	M	33 x 18		A 906 054 07 01 A 906 054 10 01	<b>20 1003 90660</b>	
<b>275</b>		<b>102</b>					
<b>OM 904</b>	<b>987</b>						
94 931 6..., 94 932 6..., 94 933 6..							
		D (LA)	4	4249 cm <sup>3</sup>	3V	130 kW (177 PS) 17,4	130,00 mm
	[50]	Ø 8 mm			A 102 053 00 26	<b>RK-8H</b>	
	IN/EX [4]	14,03 x 8 x 60,0	G2		A 906 053 01 30 A 906 053 05 29	<b>81-16107</b>	
	IN [1]	35,08 x 28 x 7,6	G1		A 906 053 01 31	<b>92-16165</b> <small>NEW</small>	
	IN [1]	35,37 x 28 x 7,7	G1		A 906 053 02 31	<b>92-16159</b>	
	EX [2]	40,38 x 31 x 8,5	G1 45°		A 906 053 02 32 A 906 053 14 32	<b>92-16160</b>	
	EX [1]	40,08 x 31 x 8,0	G1		A 906 053 16 32	<b>92-16167</b> <small>NEW</small>	
					A 904 050 04 01 A 904 050 09 01 A 904 050 40 01	<b>20 1003 90400</b>	
	[12]	M	33 x 18		A 906 054 07 01 A 906 054 10 01	<b>20 1003 90660</b>	
<b>276</b>		<b>102</b>					
<b>OM 906 Euro 2</b>	<b>936</b>						
94 705 6..., 94 706 6..., 94 707 6..., 94 931 6..., 94 932 6..., 94 933 6..., 94 971 6..							
		D (LA)	6	6374 cm <sup>3</sup>	3V	172 kW (234 PS) 17,4-18	130,00 mm
	IN [2]	34,0 x 8 x 125,9	RA/S- Cr -	- 20° - -	1 - III	A 906 050 02 26	<b>16200</b>
	IN [2]	34,0 x 8 x 128,9	RA/S- Cr -	- 20° - -	1 - III	A 906 050 03 26 A 906 050 06 26 A 906 050 07 26	<b>160056</b>
	EX [2]	15,2 x 6 x 81,6	A - -	- 20° - -	9 -	A 906 016 07 91	<b>50 009 053</b> (1)
	EX [2]	38,0 x 8 x 152,6	RA/S- Cr -	- 36° - VS -	1 - III	A 906 050 08 27 A 906 050 09 27	<b>16210</b>
	EX [2]	38,0 x 8 x 152,7	RA/S- Cr -	- 45° - -	1 - III	A 906 050 03 27 A 906 050 06 27 A 906 050 07 27	<b>160057</b>
(1) Konstantdrosselventil - flach Exhaust brake valve - flat Soupape de réduction permanente - plate Válvula de reducción permanente - plana Постоянный дроссельный клапан							
	[50]	Ø 8 mm			A 102 053 00 26	<b>RK-8H</b>	
	IN/EX [4]	13,03 x 8 x 60,0	G2		A 906 053 01 29	<b>81-16105</b>	
	IN/EX [4]	14,03 x 8 x 60,0	G2		A 906 053 01 30 A 906 053 05 29	<b>81-16107</b>	
Fortsetzung nächste Seite / continued on next page / suite page suivante / continuación página próxima / Продолжение на следующей странице							



					Reference	Item No.
	IN [1] IN [1] EX [2]  EX [1]	35,08 x 28 x 7,6 35,37 x 28 x 7,7 40,38 x 31 x 8,5  40,08 x 31.2 x 8,0	G1 G1 G1 45°  G1		A 906 053 01 31 A 906 053 02 31 A 906 053 02 32 A 906 053 14 32 A 906 053 01 32 A 906 053 12 32	<b>92-16165</b> <small>NEW</small> <b>92-16159</b> <b>92-16160</b>  <b>92-16166</b> <small>NEW</small>
	817,5 mm  818,5 mm				A 906 050 09 01 A 906 050 14 01 A 906 050 42 01 A 906 050 26 01	<b>20 1003 90600</b>  <b>20 1003 90601</b> <small>NEW</small>
	[12]	M 33 x 18			A 906 054 07 01 A 906 054 10 01	<b>20 1003 90660</b>
	- - - -	- - - - EVB			A 906 010 59 21 A 906 010 72 21	<b>20 0803 90602</b>

**277**
**106**
**M 902 Euro 5**
**900, 902 - 903**

10.2000 →

 G (LA) 6 6883 cm<sup>3</sup> 3V 170-205 kW (231-279 PS) 10,5:1 130,00 mm

40 709 6..

**M**

	IN [2] IN [2]	34,0 x 8 x 125,9 34,0 x 8 x 128,9	RA/S- Cr - RA/S- Cr -	- 20° - - - 20° - -	1 - III 1 - III	A 906 050 02 26 A 906 050 03 26 A 906 050 06 26 A 906 050 07 26	<b>16200</b> <b>160056</b>	
	EX [2] EX [2]	15,2 x 6 x 81,6 38,0 x 8 x 152,6	A - - RA/S- Cr -	- 20° - - - 36° - VS -	9 - 1 - III	A 906 016 07 91 A 906 050 08 27 A 906 050 09 27	<b>50 009 053</b> (1) <b>16210</b>	
	EX [2]	38,0 x 8 x 152,7	RA/S- Cr -	- 45° - -	1 - III	A 906 050 03 27 A 906 050 06 27 A 906 050 07 27	<b>160057</b>	
	(1)	Konstantdrosselventil - flach Exhaust brake valve - flat Soupape de réduction permanente - plate Válvula de reducción permanente - plana Постоянный дроссельный клапан						
	[50]	∅ 8 mm				A 102 053 00 26	<b>RK-8H</b>	
	IN/EX [4] IN/EX [4]	13,03 x 8 x 60,0 14,03 x 8 x 60,0	G2 G2			A 906 053 01 29 A 906 053 01 30 A 906 053 05 29	<b>81-16105</b> <b>81-16107</b>	
	IN [1] EX [2]	35,37 x 28 x 7,7 40,38 x 31 x 8,5	G1 G1 45°			A 906 053 02 31 A 906 053 02 32 A 906 053 14 32	<b>92-16159</b> <b>92-16160</b>	
		817,5 mm				A 906 050 09 01 A 906 050 14 01 A 906 050 42 01	<b>20 1003 90600</b>	
	[12]	M 33 x 18				A 906 054 07 01 A 906 054 10 01	<b>20 1003 90660</b>	

**278**
**106**
**M 902 Euro 5**
**901**

1996 →

 G (LA) 6 6883 cm<sup>3</sup> 3V 170-205 kW (231-279 PS) 10,5:1 130,00 mm

40 709 6..

Fortsetzung nächste Seite / continued on next page / suite page suivante / continuación página próxima / Продолжение на следующей странице

					Reference	Item No.
	IN [2] 34,0 x 8 x 125,9	RA/S- Cr -	- 20° - -	1 - III	A 906 050 02 26	<b>16200</b>
	IN [2] 34,0 x 8 x 128,9	RA/S- Cr -	- 20° - -	1 - III	A 906 050 03 26 A 906 050 06 26 A 906 050 07 26	<b>160056</b>
	EX [2] 15,2 x 6 x 81,6	A - -	- 20° - -	9 -	A 906 016 07 91	<b>50 009 053</b> (1)
	EX [2] 38,0 x 8 x 152,6	RA/S- Cr -	- 36° - VS -	1 - III	A 906 050 08 27 A 906 050 09 27	<b>16210</b>
	EX [2] 38,0 x 8 x 152,7	RA/S- Cr -	- 45° - -	1 - III	A 906 050 03 27 A 906 050 06 27 A 906 050 07 27	<b>160057</b>
	(1) Konstantdrosselventil - flach Exhaust brake valve - flat Soupape de réduction permanente - plate Válvula de reducción permanente - plana Постоянный дроссельный клапан					
	[50] Ø 8 mm				A 102 053 00 26	<b>RK-8H</b>
	IN/EX [4] 13,03 x 8 x 60,0	G2			A 906 053 01 29	<b>81-16105</b>
	IN/EX [4] 14,03 x 8 x 60,0	G2			A 906 053 01 30 A 906 053 05 29	<b>81-16107</b>
	IN [1] 35,37 x 28 x 7,7	G1			A 906 053 02 31	<b>92-16159</b>
	EX [2] 40,38 x 31 x 8,5	G1 45°			A 906 053 02 32 A 906 053 14 32	<b>92-16160</b>
	[12] M 33 x 18				A 906 054 07 01 A 906 054 10 01	<b>20 1003 90660</b>

## 279 106

M 906 Euro 5

900, 903

10.2000 →

G (LA) 6

6883 cm<sup>3</sup> 3V

205 kW

(279 PS) 10,5:1 130,00 mm

40 709 6..

	IN [2] 34,0 x 8 x 125,9	RA/S- Cr -	- 20° - -	1 - III	A 906 050 02 26	<b>16200</b>
	IN [2] 34,0 x 8 x 128,9	RA/S- Cr -	- 20° - -	1 - III	A 906 050 03 26 A 906 050 06 26 A 906 050 07 26	<b>160056</b>
	EX [2] 15,2 x 6 x 81,6	A - -	- 20° - -	9 -	A 906 016 07 91	<b>50 009 053</b> (1)
	EX [2] 38,0 x 8 x 152,6	RA/S- Cr -	- 36° - VS -	1 - III	A 906 050 08 27 A 906 050 09 27	<b>16210</b>
	EX [2] 38,0 x 8 x 152,7	RA/S- Cr -	- 45° - -	1 - III	A 906 050 03 27 A 906 050 06 27 A 906 050 07 27	<b>160057</b>
	(1) Konstantdrosselventil - flach Exhaust brake valve - flat Soupape de réduction permanente - plate Válvula de reducción permanente - plana Постоянный дроссельный клапан					
	[50] Ø 8 mm				A 102 053 00 26	<b>RK-8H</b>
	IN/EX [4] 13,03 x 8 x 60,0	G2			A 906 053 01 29	<b>81-16105</b>
	IN/EX [4] 14,03 x 8 x 60,0	G2			A 906 053 01 30 A 906 053 05 29	<b>81-16107</b>
	IN [1] 35,37 x 28 x 7,7	G1			A 906 053 02 31	<b>92-16159</b>
	EX [2] 40,38 x 31 x 8,5	G1 45°			A 906 053 02 32 A 906 053 14 32	<b>92-16160</b>
	818,5 mm				A 906 050 26 01	<b>20 1003 90601</b> <span style="border: 1px solid black; padding: 2px;">NEW</span>
	[12] M 33 x 18				A 906 054 07 01 A 906 054 10 01	<b>20 1003 90660</b>

					Reference	Item No.	
<b>280</b>		<b>106</b>					
<b>M 906 Euro 5</b>		<b>901</b>	G (LA)	6	6883 cm <sup>3</sup> 3V	170 kW (231 PS) 10,5:1 130,00 mm	
40 709 6..							
	IN [2] IN [2]	34,0 x 8 x 125,9 34,0 x 8 x 128,9	RA/S- Cr - RA/S- Cr -	- 20° - - - 20° - -	1 - III 1 - III	A 906 050 02 26 A 906 050 03 26 A 906 050 06 26 A 906 050 07 26 <b>16200</b> <b>160056</b>	
	EX [2] EX [2]	15,2 x 6 x 81,6 38,0 x 8 x 152,6	A - - RA/S- Cr -	- 20° - - - 36° - VS -	9 - 1 - III	A 906 016 07 91 A 906 050 08 27 A 906 050 09 27 <b>50 009 053</b> (1) <b>16210</b>	
	EX [2]	38,0 x 8 x 152,7	RA/S- Cr -	- 45° - -	1 - III	A 906 050 03 27 A 906 050 06 27 A 906 050 07 27 <b>160057</b>	
	(1)	Konstantdrosselventil - flach Exhaust brake valve - flat Soupape de réduction permanente - plate Válvula de reducción permanente - plana Постоянный дроссельный клапан					
	[50]	Ø 8 mm				A 102 053 00 26 <b>RK-8H</b>	
	IN/EX [4] IN/EX [4]	13,03 x 8 x 60,0 14,03 x 8 x 60,0	G2 G2			A 906 053 01 29 A 906 053 01 30 A 906 053 05 29 <b>81-16105</b> <b>81-16107</b>	
	IN [1] EX [2]	35,37 x 28 x 7,7 40,38 x 31 x 8,5	G1 G1 45°			A 906 053 02 31 A 906 053 02 32 A 906 053 14 32 A 906 053 16 32 <b>92-16159</b> <b>92-16160</b>	
	EX [1]	40,08 x 31 x 8,0	G1			A 906 053 16 32 <b>92-16167</b> <small>NEW</small>	
		818,5 mm				A 906 050 26 01 <b>20 1003 90601</b> <small>NEW</small>	
	[12]	M 33 x 18				A 906 054 07 01 A 906 054 10 01 <b>20 1003 90660</b>	
<b>281</b>		<b>106</b>					
<b>OM 924 Euro 5</b>		<b>933</b>					
		01.2002→	D (LA)	4	4801 cm <sup>3</sup> 3V	142 kW (193 PS) 17,4:1 136,00 mm	
<b>OM 924 Euro 3</b>		<b>919, 925</b>					
		06.1971→	D (LA)	4	4801 cm <sup>3</sup> 3V	142-160 kW (193-218 PS) 17,4:1 136,00 mm	
40 026 6.., 40 078 6.., 40 284 6..							
	IN [2] IN [2]	34,0 x 8 x 125,9 34,0 x 8 x 128,9	RA/S- Cr - RA/S- Cr -	- 20° - - - 20° - -	1 - III 1 - III	A 906 050 02 26 A 906 050 03 26 A 906 050 06 26 A 906 050 07 26 <b>16200</b> <b>160056</b>	
	EX [2] EX [2]	15,2 x 6 x 81,6 38,0 x 8 x 152,6	A - - RA/S- Cr -	- 20° - - - 36° - VS -	9 - 1 - III	A 906 016 07 91 A 906 050 08 27 A 906 050 09 27 <b>50 009 053</b> (1) <b>16210</b>	
	EX [2]	38,0 x 8 x 152,7	RA/S- Cr -	- 45° - -	1 - III	A 906 050 03 27 A 906 050 06 27 A 906 050 07 27 <b>160057</b>	
	(1)	Konstantdrosselventil - flach Exhaust brake valve - flat Soupape de réduction permanente - plate Válvula de reducción permanente - plana Постоянный дроссельный клапан					
	[50]	Ø 8 mm				A 102 053 00 26 <b>RK-8H</b>	
Fortsetzung nächste Seite / continued on next page / suite page suivante / continuación página próxima / Продолжение на следующей странице							

					Reference	Item No.
	IN/EX [4]	13,03 x 8 x 60,0	G2		A 906 053 01 29	<b>81-16105</b>
	IN/EX [4]	14,03 x 8 x 60,0	G2		A 906 053 01 30 A 906 053 05 29	<b>81-16107</b>
	IN [1]	35,08 x 28 x 7,6	G1		A 906 053 01 31	<b>92-16165</b> <small>NEW</small>
	IN [1]	35,37 x 28 x 7,7	G1		A 906 053 02 31	<b>92-16159</b>
	EX [2]	40,38 x 31 x 8,5	G1 45°		A 906 053 02 32 A 906 053 14 32	<b>92-16160</b>
	EX [1]	40,08 x 31 x 8,0	G1		A 906 053 16 32	<b>92-16167</b> <small>NEW</small>
	EX [1]	40,08 x 31.2 x 8,0	G1		A 906 053 01 32 A 906 053 12 32	<b>92-16166</b> <small>NEW</small>
	[12]	M 33 x 18			A 906 054 07 01 A 906 054 10 01	<b>20 1003 90660</b>

## 282 106

**OM 926 Euro 3 913, 920, 926 - 928**

D (LA) 6 7201 cm<sup>3</sup> 3V 187-240 kW (254-326 PS) 136,00 mm

**OM 926 Euro 4 941, 950**

D (LA) 6 7201 cm<sup>3</sup> 3V 194-205 kW (264-279 PS) 17:1 136,00 mm

**OM 926 Euro 4/5 960 - 961**

2007 →

D (LA) 6 7201 cm<sup>3</sup> 3V 175-240 kW (238-326 PS) 17,4:1 136,00 mm

40 026 6..., 40 078 6..., 40 284 6..., 41 003 6..

	IN [2]	34,0 x 8 x 125,9	RA/S- Cr -	- 20° - -	1 - III	A 906 050 02 26	<b>16200</b>
	IN [2]	34,0 x 8 x 128,9	RA/S- Cr -	- 20° - -	1 - III	A 906 050 03 26 A 906 050 06 26 A 906 050 07 26	<b>160056</b>
	EX [2]	15,2 x 6 x 81,6	A - -	- 20° - -	9 -	A 906 016 07 91	<b>50 009 053</b> (1)
	EX [2]	38,0 x 8 x 152,6	RA/S- Cr -	- 36° - VS -	1 - III	A 906 050 08 27 A 906 050 09 27	<b>16210</b>
	EX [2]	38,0 x 8 x 152,7	RA/S- Cr -	- 45° - -	1 - III	A 906 050 03 27 A 906 050 06 27 A 906 050 07 27	<b>160057</b>
	(1) Konstantdrosselventil - flach Exhaust brake valve - flat Soupape de réduction permanente - plate Válvula de reducción permanente - plana Постоянный дроссельный клапан						

	[50]	Ø 8 mm				A 102 053 00 26	<b>RK-8H</b>
--	------	--------	--	--	--	-----------------	--------------

	IN/EX [4]	13,03 x 8 x 60,0	G2			A 906 053 01 29	<b>81-16105</b>
	IN/EX [4]	14,03 x 8 x 60,0	G2			A 906 053 01 30 A 906 053 05 29	<b>81-16107</b>

	IN [1]	35,08 x 28 x 7,6	G1			A 906 053 01 31	<b>92-16165</b> <small>NEW</small>
	IN [1]	35,37 x 28 x 7,7	G1			A 906 053 02 31	<b>92-16159</b>
	EX [2]	40,38 x 31 x 8,5	G1 45°			A 906 053 02 32 A 906 053 14 32	<b>92-16160</b>
	EX [1]	40,08 x 31 x 8,0	G1			A 906 053 16 32	<b>92-16167</b> <small>NEW</small>
	EX [1]	40,08 x 31.2 x 8,0	G1			A 906 053 01 32 A 906 053 12 32	<b>92-16166</b> <small>NEW</small>

		817,5 mm				A 906 050 09 01 A 906 050 14 01 A 906 050 42 01	<b>20 1003 90600</b>
--	--	----------	--	--	--	---	----------------------

		818,5 mm				A 906 050 26 01	<b>20 1003 90601</b> <small>NEW</small>
--	--	----------	--	--	--	-----------------	---

	[12]	M 33 x 18				A 906 054 07 01 A 906 054 10 01	<b>20 1003 90660</b>
--	------	-----------	--	--	--	------------------------------------	----------------------

Fortsetzung nächste Seite / continued on next page / suite page suivante / continuación página próxima / Продолжение на следующей странице

					Reference	Item No.
	- - - -	- - - EVB			A 906 010 59 21 A 906 010 72 21	<b>20 0803 90602</b>

## 283 106

OM 924 Euro 3 **914, 928 - 929**

D (LA) 4 4801 cm<sup>3</sup> 3V 142-160 kW (193-218 PS) 17,4:1 136,00 mm

40 026 6.., 40 033 6.., 40 078 6.., 40 284 6..

	IN [2]	34,0 x 8 x 125,9	RA/S- Cr -	- 20° - -	1 - III	A 906 050 02 26	<b>16200</b>
	IN [2]	34,0 x 8 x 128,9	RA/S- Cr -	- 20° - -	1 - III	A 906 050 03 26 A 906 050 06 26 A 906 050 07 26	<b>160056</b>
	EX [2]	15,2 x 6 x 81,6	A - -	- 20° - -	9 -	A 906 016 07 91	<b>50 009 053</b> (1)
	EX [2]	38,0 x 8 x 152,6	RA/S- Cr -	- 36° - VS -	1 - III	A 906 050 08 27 A 906 050 09 27	<b>16210</b>
	EX [2]	38,0 x 8 x 152,7	RA/S- Cr -	- 45° - -	1 - III	A 906 050 03 27 A 906 050 06 27 A 906 050 07 27	<b>160057</b>
	(1) Konstantdrosselventil - flach Exhaust brake valve - flat Soupape de réduction permanente - plate Válvula de reducción permanente - plana Постоянный дроссельный клапан						
	[50]	∅ 8 mm				A 102 053 00 26	<b>RK-8H</b>
	IN/EX [4]	13,03 x 8 x 60,0	G2			A 906 053 01 29	<b>81-16105</b>
	IN/EX [4]	14,03 x 8 x 60,0	G2			A 906 053 01 30 A 906 053 05 29	<b>81-16107</b>
	IN [1]	35,08 x 28 x 7,6	G1			A 906 053 01 31	<b>92-16165</b> <small>NEW</small>
	IN [1]	35,37 x 28 x 7,7	G1			A 906 053 02 31	<b>92-16159</b>
	EX [2]	40,38 x 31 x 8,5	G1 45°			A 906 053 02 32 A 906 053 14 32	<b>92-16160</b>
	EX [1]	40,08 x 31 x 8,0	G1			A 906 053 16 32	<b>92-16167</b> <small>NEW</small>
						A 904 050 04 01 A 904 050 09 01 A 904 050 40 01	<b>20 1003 90400</b>
	[12]	M 33 x 18				A 906 054 07 01 A 906 054 10 01	<b>20 1003 90660</b>

## 284 106

OM 924 Euro 5 **935**

10.2004 → D (LA) 4 4801 cm<sup>3</sup> 3V 115 kW (156 PS) 136,00 mm

OM 925 Euro 5 **920**

10.2004 → D (LA) 6 7201 cm<sup>3</sup> 3V 175-210 kW (238-286 PS) 136,00 mm

OM 926 **973, 975 - 976**

01.1996 → D (LA) 6 7201 cm<sup>3</sup> 3V 175-188 kW (238-256 PS) 136,00 mm

40 270 6..

	IN [2]	34,0 x 8 x 128,9	RA/S- Cr -	- 20° - -	1 - III	A 906 050 03 26 A 906 050 06 26 A 906 050 07 26	<b>160056</b>
	EX [2]	38,0 x 8 x 152,6	RA/S- Cr -	- 36° - VS -	1 - III	A 906 050 08 27 A 906 050 09 27	<b>16210</b>
	[50]	∅ 8 mm				A 102 053 00 26	<b>RK-8H</b>

Fortsetzung nächste Seite / continued on next page / suite page suivante / continuación página próxima / Продолжение на следующей странице



					Reference	Item No.
IN [1] EX [1]	35,08 x 28 x 7,6 40,08 x 31 x 8,0	G1 G1			A 906 053 01 31 A 906 053 16 32	<b>92-16165</b> <small>NEW</small> <b>92-16167</b> <small>NEW</small>
<b>285</b> <b>106</b>						
OM 926 Euro 5 <b>996, 999</b> 01.1996 → D (LA) 6 7201 cm <sup>3</sup> 3V 188-228 kW (256-310 PS) 17:1 136,00 mm						
IN/EX [4] IN/EX [4]	13,03 x 8 x 60,0 14,03 x 8 x 60,0	G2 G2			A 906 053 01 29 A 906 053 01 30 A 906 053 05 29	<b>81-16105</b> <b>81-16107</b>
IN [1] IN [1] EX [2]	35,08 x 28 x 7,6 35,37 x 28 x 7,7 40,38 x 31 x 8,5	G1 G1 G1 45°			A 906 053 01 31 A 906 053 02 31 A 906 053 02 32 A 906 053 14 32	<b>92-16165</b> <small>NEW</small> <b>92-16159</b> <b>92-16160</b>
EX [1] EX [1]	40,08 x 31 x 8,0 40,08 x 31.2 x 8,0	G1 G1			A 906 053 16 32 A 906 053 01 32 A 906 053 12 32	<b>92-16167</b> <small>NEW</small> <b>92-16166</b> <small>NEW</small>
	- - - -	- - - EVB			A 906 010 59 21 A 906 010 72 21	<b>20 0803 90602</b>
<b>286</b> <b>106</b>						
OM 926 Euro 4 <b>937, 939</b> 08.1998 → D (LA) 6 7201 cm <sup>3</sup> 3V 210-240 kW (286-326 PS) 17:1 136,00 mm						
40 332 6..						
IN [2] IN [2]	34,0 x 8 x 125,9 34,0 x 8 x 128,9	RA/S- Cr - RA/S- Cr -	- 20° - - - 20° - -	1 - III 1 - III	A 906 050 02 26 A 906 050 03 26 A 906 050 06 26 A 906 050 07 26	<b>16200</b> <b>160056</b>
EX [2] EX [2]	15,2 x 6 x 81,6 38,0 x 8 x 152,6	A - - RA/S- Cr -	- 20° - - - 36° - VS -	9 - 1 - III	A 906 016 07 91 A 906 050 08 27 A 906 050 09 27	<b>50 009 053</b> (1) <b>16210</b>
EX [2]	38,0 x 8 x 152,7	RA/S- Cr -	- 45° - -	1 - III	A 906 050 03 27 A 906 050 06 27 A 906 050 07 27	<b>160057</b>
(1) Konstantdrosselventil - flach Exhaust brake valve - flat Soupape de réduction permanente - plate Válvula de reducción permanente - plana Постоянный дроссельный клапан						
[50]	Ø 8 mm				A 102 053 00 26	<b>RK-8H</b>
IN/EX [4] IN/EX [4]	13,03 x 8 x 60,0 14,03 x 8 x 60,0	G2 G2			A 906 053 01 29 A 906 053 01 30 A 906 053 05 29	<b>81-16105</b> <b>81-16107</b>
IN [1] IN [1] EX [2]	35,08 x 28 x 7,6 35,37 x 28 x 7,7 40,38 x 31 x 8,5	G1 G1 G1 45°			A 906 053 01 31 A 906 053 02 31 A 906 053 02 32 A 906 053 14 32	<b>92-16165</b> <small>NEW</small> <b>92-16159</b> <b>92-16160</b>
EX [1] EX [1]	40,08 x 31 x 8,0 40,08 x 31.2 x 8,0	G1 G1			A 906 053 16 32 A 906 053 01 32 A 906 053 12 32	<b>92-16167</b> <small>NEW</small> <b>92-16166</b> <small>NEW</small>
Fortsetzung nächste Seite / continued on next page / suite page suivante / continuación página próxima / Продолжение на следующей странице						

M

					Reference	Item No.
	818,5 mm				A 906 050 26 01 A 906 050 32 01 A 906 050 40 01	<b>20 1003 90601</b> <small>NEW</small> <b>20 1003 90605</b>
	[12] M 33 x 18				A 906 054 07 01 A 906 054 10 01	<b>20 1003 90660</b>
	- - - -	- - - EVB			A 906 010 59 21 A 906 010 72 21	<b>20 0803 90602</b>

## 287

<b>OM 923</b>	<b>938</b>	D (LA)	4	4800 cm <sup>3</sup>			136,00 mm
<b>OM 923</b>	<b>934 - 937</b>	D (LA)	4	4800 cm <sup>3</sup>	3V		136,00 mm
<b>OM 924</b>	<b>938</b>	D (LA)	4	4801 cm <sup>3</sup>	3V	115-160 kW (156-218 PS)	136,00 mm
<b>OM 924 Euro 5</b>	<b>936 - 937, 988 - 989</b>	D (LA)	4	4801 cm <sup>3</sup>	3V	95-150 kW (129-204 PS)	136,00 mm
	05.1999 →	D (LA)	4	4801 cm <sup>3</sup>	3V	95-150 kW (129-204 PS)	136,00 mm
<b>OM 925</b>	<b>945 - 949, 959, 970 - 976</b>	D (LA)	6	7201 cm <sup>3</sup>	3V		136,00 mm
<b>OM 925 Euro 5</b>	<b>960</b>	D (LA)	6	7201 cm <sup>3</sup>	3V	240 kW (326 PS)	136,00 mm
<b>OM 926</b>	<b>970 - 972</b>	D (LA)	6	7201 cm <sup>3</sup>	3V	175-240 kW (238-326 PS)	136,00 mm

40 270 6.., 41 003 6..

	IN [1] 35,08 x 28 x 7,6 EX [1] 40,08 x 31 x 8,0	G1 G1				A 906 053 01 31 A 906 053 16 32	<b>92-16165</b> <small>NEW</small> <b>92-16167</b> <small>NEW</small>
--	--	----------	--	--	--	------------------------------------	--

## 288

<b>OM 926 Euro 3</b>	<b>910, 935</b>	D (LA)	6	7201 cm <sup>3</sup>	3V	240 kW (326 PS)	136,00 mm
<b>OM 926 Euro 2</b>	<b>911 - 912</b>	D (LA)	6	7201 cm <sup>3</sup>	3V	240 kW (326 PS)	17:1 136,00 mm

40 033 6.., 40 078 6..

	IN [2] 34,0 x 8 x 125,9 IN [2] 34,0 x 8 x 128,9	RA/S- Cr - RA/S- Cr -	- 20° - - - 20° - -	1 - III 1 - III	A 906 050 02 26 A 906 050 03 26 A 906 050 06 26 A 906 050 07 26	<b>16200</b> <b>160056</b>
	EX [2] 15,2 x 6 x 81,6 EX [2] 38,0 x 8 x 152,6	A - - RA/S- Cr -	- 20° - - - 36° - VS -	9 - 1 - III	A 906 016 07 91 A 906 050 08 27 A 906 050 09 27	<b>50 009 053</b> (1) <b>16210</b>
	EX [2] 38,0 x 8 x 152,7	RA/S- Cr -	- 45° - -	1 - III	A 906 050 03 27 A 906 050 06 27 A 906 050 07 27	<b>160057</b>
	(1) Konstantdrosselventil - flach Exhaust brake valve - flat Soupape de réduction permanente - plate Válvula de reducción permanente - plana Постоянный дроссельный клапан					
	[50] Ø 8 mm				A 102 053 00 26	<b>RK-8H</b>
	IN/EX [4] 13,03 x 8 x 60,0 IN/EX [4] 14,03 x 8 x 60,0	G2 G2			A 906 053 01 29 A 906 053 01 30 A 906 053 05 29	<b>81-16105</b> <b>81-16107</b>

Fortsetzung nächste Seite / continued on next page / suite page suivante / continuación página próxima / Продолжение на следующей странице

					Reference	Item No.
	IN [1] IN [1] EX [2]  EX [1]	35,08 x 28 x 7,6 35,37 x 28 x 7,7 40,38 x 31 x 8,5  40,08 x 31 x 8,0	G1 G1 G1 45°  G1		A 906 053 01 31 A 906 053 02 31 A 906 053 02 32 A 906 053 14 32 A 906 053 16 32	<b>92-16165</b> <small>NEW</small> <b>92-16159</b> <b>92-16160</b>  <b>92-16167</b> <small>NEW</small>
		817,5 mm  818,5 mm			A 906 050 09 01 A 906 050 14 01 A 906 050 42 01 A 906 050 26 01	<b>20 1003 90600</b>  <b>20 1003 90601</b> <small>NEW</small>
	[12]	M 33 x 18			A 906 054 07 01 A 906 054 10 01	<b>20 1003 90660</b>
		- - - -	- - - EVB		A 906 010 59 21 A 906 010 72 21	<b>20 0803 90602</b>

## 289 106

OM 926 Euro 3 915 - 916, 930

2000 →

D (LA) 6 7201 cm<sup>3</sup> 3V 225-240 kW (306-326 PS) 17:1 136,00 mm

OM 926 Euro 2 914

D (LA) 6 7201 cm<sup>3</sup> 3V 240 kW (326 PS) 17:1 136,00 mm

40 026 6..., 40 078 6..., 40 284 6..

	IN [2] IN [2]	34,0 x 8 x 125,9 34,0 x 8 x 128,9	RA/S- Cr - RA/S- Cr -	- 20° - - - 20° - -	1 - III 1 - III	A 906 050 02 26 A 906 050 03 26 A 906 050 06 26 A 906 050 07 26	<b>16200</b> <b>160056</b>
	EX [2] EX [2]	15,2 x 6 x 81,6 38,0 x 8 x 152,6	A - - RA/S- Cr -	- 20° - - - 36° - VS -	9 - 1 - III	A 906 016 07 91 A 906 050 08 27 A 906 050 09 27	<b>50 009 053</b> (1) <b>16210</b>
	EX [2]	38,0 x 8 x 152,7	RA/S- Cr -	- 45° - -	1 - III	A 906 050 03 27 A 906 050 06 27 A 906 050 07 27	<b>160057</b>
	(1)	Konstantdrosselventil - flach Exhaust brake valve - flat Soupape de réduction permanente - plate Válvula de reducción permanente - plana Постоянный дроссельный клапан					
	[50]	∅ 8 mm				A 102 053 00 26	<b>RK-8H</b>
	IN/EX [4] IN/EX [4]	13,03 x 8 x 60,0 14,03 x 8 x 60,0	G2 G2			A 906 053 01 29 A 906 053 01 30 A 906 053 05 29	<b>81-16105</b> <b>81-16107</b>
	IN [1] IN [1] EX [2]  EX [1] EX [1]	35,08 x 28 x 7,6 35,37 x 28 x 7,7 40,38 x 31 x 8,5  40,08 x 31 x 8,0 40,08 x 31.2 x 8,0	G1 G1 G1 45°  G1 G1			A 906 053 01 31 A 906 053 02 31 A 906 053 02 32 A 906 053 14 32 A 906 053 16 32 A 906 053 01 32 A 906 053 12 32	<b>92-16165</b> <small>NEW</small> <b>92-16159</b> <b>92-16160</b>  <b>92-16167</b> <small>NEW</small> <b>92-16166</b> <small>NEW</small>
		817,5 mm				A 906 050 09 01 A 906 050 14 01 A 906 050 42 01	<b>20 1003 90600</b>
	[12]	M 33 x 18				A 906 054 07 01 A 906 054 10 01	<b>20 1003 90660</b>

Fortsetzung nächste Seite / continued on next page / suite page suivante / continuación página próxima / Продолжение на следующей странице

					Reference	Item No.
	- - - -	- - - EVB			A 906 010 59 21 A 906 010 72 21	<b>20 0803 90602</b>

## 290 106

<b>OM 924 Euro 3</b>	<b>910, 912, 915 - 917, 920</b>	D (LA)	4	4801 cm <sup>3</sup>	3V	142-160 kW	(193-218 PS)	17,4:1	136,00 mm
<b>OM 924 Euro 2</b>	<b>911</b>	D (LA)	4	4801 cm <sup>3</sup>	3V	160 kW	(218 PS)	17,4:1	136,00 mm
	08.2016 →								
<b>OM 924 Euro 4</b>	<b>922 - 923</b>	D (LA)	4	4801 cm <sup>3</sup>	3V	160 kW	(218 PS)	17,4:1	136,00 mm
	09.2002 →								
40 026 6.., 40 033 6.., 40 078 6.., 40 284 6.., 40 332 6.., 94 705 6.., 94 706 6.., 94 707 6.., 94 971 6..									

	IN [2]	34,0 x 8 x 125,9	RA/S- Cr -	- 20° - -	1 - III	A 906 050 02 26	<b>16200</b>		
	IN [2]	34,0 x 8 x 128,9	RA/S- Cr -	- 20° - -	1 - III	A 906 050 03 26 A 906 050 06 26 A 906 050 07 26	<b>160056</b>		
	EX [2]	15,2 x 6 x 81,6	A - -	- 20° - -	9 -	A 906 016 07 91	<b>50 009 053</b>	(1)	
	EX [2]	38,0 x 8 x 152,6	RA/S- Cr -	- 36° - VS -	1 - III	A 906 050 08 27 A 906 050 09 27	<b>16210</b>		
	EX [2]	38,0 x 8 x 152,7	RA/S- Cr -	- 45° - -	1 - III	A 906 050 03 27 A 906 050 06 27 A 906 050 07 27	<b>160057</b>		
	(1)	Konstantdrosselventil - flach Exhaust brake valve - flat Soupape de réduction permanente - plate Válvula de reducción permanente - plana Постоянный дроссельный клапан							

	[50]	Ø 8 mm				A 102 053 00 26	<b>RK-8H</b>		
--	------	--------	--	--	--	-----------------	--------------	--	--

	IN/EX [4]	13,03 x 8 x 60,0	G2			A 906 053 01 29	<b>81-16105</b>		
	IN/EX [4]	14,03 x 8 x 60,0	G2			A 906 053 01 30 A 906 053 05 29	<b>81-16107</b>		

	IN [1]	35,08 x 28 x 7,6	G1			A 906 053 01 31	<b>92-16165</b> <small>NEW</small>		
	IN [1]	35,37 x 28 x 7,7	G1			A 906 053 02 31	<b>92-16159</b>		
	EX [2]	40,38 x 31 x 8,5	G1 45°			A 906 053 02 32 A 906 053 14 32	<b>92-16160</b>		
	EX [1]	40,08 x 31 x 8,0	G1			A 906 053 16 32	<b>92-16167</b> <small>NEW</small>		
	EX [1]	40,08 x 31.2 x 8,0	G1			A 906 053 01 32 A 906 053 12 32	<b>92-16166</b> <small>NEW</small>		

						A 904 050 04 01 A 904 050 09 01 A 904 050 40 01	<b>20 1003 90400</b>		
--	--	--	--	--	--	---	----------------------	--	--

	[12]	M 33 x 18				A 906 054 07 01 A 906 054 10 01	<b>20 1003 90660</b>		
--	------	-----------	--	--	--	------------------------------------	----------------------	--	--

## 291 106

<b>OM 926 Euro 3</b>	<b>917, 921, 924, 932, 942</b>	D (LA)	6	7201 cm <sup>3</sup>	3V	224-240 kW	(305-326 PS)	17:1	136,00 mm
40 026 6.., 40 033 6.., 40 078 6.., 40 284 6..									

Fortsetzung nächste Seite / continued on next page / suite page suivante / continuación página próxima / Продолжение на следующей странице

					Reference	Item No.
	IN [2] 34,0 x 8 x 125,9 IN [2] 34,0 x 8 x 128,9	RA/S- Cr - RA/S- Cr -	- 20° - - - 20° - -	1 - III 1 - III	A 906 050 02 26 A 906 050 03 26 A 906 050 06 26 A 906 050 07 26	<b>16200</b> <b>160056</b>
	EX [2] 15,2 x 6 x 81,6 EX [2] 38,0 x 8 x 152,6	A - - RA/S- Cr -	- 20° - - - 36° - VS -	9 - 1 - III	A 906 016 07 91 A 906 050 08 27 A 906 050 09 27	<b>50 009 053</b> (1) <b>16210</b>
	EX [2] 38,0 x 8 x 152,7	RA/S- Cr -	- 45° - -	1 - III	A 906 050 03 27 A 906 050 06 27 A 906 050 07 27	<b>160057</b>
	(1) Konstantdrosselventil - flach Exhaust brake valve - flat Soupape de réduction permanente - plate Válvula de reducción permanente - plana Постоянный дроссельный клапан					
	[50] Ø 8 mm				A 102 053 00 26	<b>RK-8H</b>
	IN/EX [4] 13,03 x 8 x 60,0 IN/EX [4] 14,03 x 8 x 60,0	G2 G2			A 906 053 01 29 A 906 053 01 30 A 906 053 05 29	<b>81-16105</b> <b>81-16107</b>
	IN [1] 35,08 x 28 x 7,6 IN [1] 35,37 x 28 x 7,7 EX [2] 40,38 x 31 x 8,5	G1 G1 G1 45°			A 906 053 01 31 A 906 053 02 31 A 906 053 02 32 A 906 053 14 32	<b>92-16165</b> <b>92-16159</b> <b>92-16160</b>
	EX [1] 40,08 x 31 x 8,0 EX [1] 40,08 x 31.2 x 8,0	G1 G1			A 906 053 16 32 A 906 053 01 32 A 906 053 12 32	<b>92-16167</b> <b>92-16166</b>
	[12] M 33 x 18				A 906 054 07 01 A 906 054 10 01	<b>20 1003 90660</b>
	- - - - 	- - - -	- - - - EVB		A 906 010 59 21 A 906 010 72 21	<b>20 0803 90602</b>

**292** **106**

OM 926 Euro 4

919, 934

D (LA) 6 7201 cm<sup>3</sup> 3V 240 kW (326 PS) 17:1 136,00 mm

40 332 6..

	IN [2] 34,0 x 8 x 125,9 IN [2] 34,0 x 8 x 128,9	RA/S- Cr - RA/S- Cr -	- 20° - - - 20° - -	1 - III 1 - III	A 906 050 02 26 A 906 050 03 26 A 906 050 06 26 A 906 050 07 26	<b>16200</b> <b>160056</b>
	EX [2] 15,2 x 6 x 81,6 EX [2] 38,0 x 8 x 152,6	A - - RA/S- Cr -	- 20° - - - 36° - VS -	9 - 1 - III	A 906 016 07 91 A 906 050 08 27 A 906 050 09 27	<b>50 009 053</b> (1) <b>16210</b>
	EX [2] 38,0 x 8 x 152,7	RA/S- Cr -	- 45° - -	1 - III	A 906 050 03 27 A 906 050 06 27 A 906 050 07 27	<b>160057</b>
	(1) Konstantdrosselventil - flach Exhaust brake valve - flat Soupape de réduction permanente - plate Válvula de reducción permanente - plana Постоянный дроссельный клапан					
	[50] Ø 8 mm				A 102 053 00 26	<b>RK-8H</b>

Fortsetzung nächste Seite / continued on next page / suite page suivante / continuación página próxima / Продолжение на следующей странице



					Reference	Item No.
	IN/EX [4] 13,03 x 8 x 60,0 IN/EX [4] 14,03 x 8 x 60,0	G2 G2			A 906 053 01 29 A 906 053 01 30 A 906 053 05 29	<b>81-16105</b> <b>81-16107</b>
	IN [1] 35,08 x 28 x 7,6 IN [1] 35,37 x 28 x 7,7 EX [2] 40,38 x 31 x 8,5	G1 G1 G1 45°			A 906 053 01 31 A 906 053 02 31 A 906 053 02 32 A 906 053 14 32 A 906 053 16 32 A 906 053 01 32 A 906 053 12 32	<b>92-16165</b> <small>NEW</small> <b>92-16159</b> <b>92-16160</b> <b>92-16167</b> <small>NEW</small> <b>92-16166</b> <small>NEW</small>
	EX [1] 40,08 x 31 x 8,0 EX [1] 40,08 x 31.2 x 8,0	G1 G1				
					A 906 050 32 01 A 906 050 40 01	<b>20 1003 90605</b>
	M 33 x 18				A 906 054 07 01 A 906 054 10 01	<b>20 1003 90660</b>
	- - - -	- - - EVV			A 906 010 59 21 A 906 010 72 21	<b>20 0803 90602</b>

**293** **106**

**OM 924 Euro 3 924**

D (LA) 4 4801 cm<sup>3</sup> 3V 160 kW (218 PS) 17,4:1 136,00 mm

40 078 6..

	IN [2] 34,0 x 8 x 125,9 IN [2] 34,0 x 8 x 128,9	RA/S- Cr - RA/S- Cr -	- 20° - - - 20° - -	1 - III 1 - III	A 906 050 02 26 A 906 050 03 26 A 906 050 06 26 A 906 050 07 26	<b>16200</b> <b>160056</b>
	EX [2] 15,2 x 6 x 81,6 EX [2] 38,0 x 8 x 152,6	A - - RA/S- Cr -	- 20° - - - 36° - VS -	9 - 1 - III	A 906 016 07 91 A 906 050 08 27 A 906 050 09 27 A 906 050 03 27 A 906 050 06 27 A 906 050 07 27	<b>50 009 053</b> (1) <b>16210</b> <b>160057</b>
	(1) Konstantdrosselventil - flach Exhaust brake valve - flat Soupape de réduction permanente - plate Válvula de reducción permanente - plana Постоянный дроссельный клапан					
	[50] Ø 8 mm				A 102 053 00 26	<b>RK-8H</b>
	IN/EX [4] 13,03 x 8 x 60,0 IN/EX [4] 14,03 x 8 x 60,0	G2 G2			A 906 053 01 29 A 906 053 01 30 A 906 053 05 29	<b>81-16105</b> <b>81-16107</b>
	IN [1] 35,08 x 28 x 7,6 IN [1] 35,37 x 28 x 7,7 EX [2] 40,38 x 31 x 8,5	G1 G1 G1 45°			A 906 053 01 31 A 906 053 02 31 A 906 053 02 32 A 906 053 14 32 A 906 053 16 32 A 906 053 01 32 A 906 053 12 32	<b>92-16165</b> <small>NEW</small> <b>92-16159</b> <b>92-16160</b> <b>92-16166</b> <small>NEW</small>
	EX [1] 40,08 x 31.2 x 8,0	G1				
	[12] M 33 x 18				A 906 054 07 01 A 906 054 10 01	<b>20 1003 90660</b>

**M**

					Reference	Item No.	
<b>294</b>		<b>106</b>	<b>OM 924 Euro 5</b> <b>930</b> 10.2004 →      D (LA) 4 4801 cm <sup>3</sup> 3V 136-160 kW (185-218 PS) 17,4:1 136,00 mm 40 270 6..., 41 003 6..				
	IN [2] IN [2]	34,0 x 8 x 125,9 34,0 x 8 x 128,9	RA/S- Cr - RA/S- Cr -	- 20° - - - 20° - -	1 - III 1 - III	A 906 050 02 26 A 906 050 03 26 A 906 050 06 26 A 906 050 07 26 A 906 016 07 91 A 906 050 08 27 A 906 050 09 27 A 906 050 03 27 A 906 050 06 27 A 906 050 07 27	<b>16200</b> <b>160056</b>  <b>50 009 053</b> (1) <b>16210</b>  <b>160057</b>
	EX [2] EX [2]  EX [2]	15,2 x 6 x 81,6 38,0 x 8 x 152,6  38,0 x 8 x 152,7	A - - RA/S- Cr - RA/S- Cr -	- 20° - - - 36° - VS - - 45° - -	9 - 1 - III 1 - III	A 906 016 07 91 A 906 050 08 27 A 906 050 09 27 A 906 050 03 27 A 906 050 06 27 A 906 050 07 27	<b>50 009 053</b> (1) <b>16210</b>  <b>160057</b>
	(1)	Konstantdrosselventil - flach Exhaust brake valve - flat Soupape de réduction permanente - plate Válvula de reducción permanente - plana Постоянный дроссельный клапан					
	[50]	∅ 8 mm				A 102 053 00 26	<b>RK-8H</b>
	IN/EX [4] IN/EX [4]	13,03 x 8 x 60,0 14,03 x 8 x 60,0	G2 G2			A 906 053 01 29 A 906 053 01 30 A 906 053 05 29	<b>81-16105</b> <b>81-16107</b>
	IN [1] IN [1] EX [2]  EX [1] EX [1]	35,08 x 28 x 7,6 35,37 x 28 x 7,7 40,38 x 31 x 8,5  40,08 x 31 x 8,0 40,08 x 31.2 x 8,0	G1 G1 G1 45°  G1 G1			A 906 053 01 31 A 906 053 02 31 A 906 053 02 32 A 906 053 14 32 A 906 053 16 32 A 906 053 01 32 A 906 053 12 32	<b>92-16165</b> <b>92-16159</b> <b>92-16160</b>  <b>92-16167</b> <b>92-16166</b>
						A 904 050 04 01 A 904 050 09 01 A 904 050 40 01	<b>20 1003 90400</b>
<b>295</b>		<b>106</b>	<b>OM 926 Euro 5</b> <b>945, 948</b> 10.2004 →      D (LA) 6 7201 cm <sup>3</sup> 3V 240 kW (326 PS) 17:1 136,00 mm <b>OM 926 Euro 3</b> <b>918</b> D (LA) 6 7201 cm <sup>3</sup> 3V 215 kW (292 PS) 17:1 136,00 mm 40 270 6..., 41 003 6..				
	IN [2] IN [2]	34,0 x 8 x 125,9 34,0 x 8 x 128,9	RA/S- Cr - RA/S- Cr -	- 20° - - - 20° - -	1 - III 1 - III	A 906 050 02 26 A 906 050 03 26 A 906 050 06 26 A 906 050 07 26 A 906 016 07 91 A 906 050 08 27 A 906 050 09 27 A 906 050 03 27 A 906 050 06 27 A 906 050 07 27	<b>16200</b> <b>160056</b>  <b>50 009 053</b> (1) <b>16210</b>  <b>160057</b>
	EX [2] EX [2]  EX [2]	15,2 x 6 x 81,6 38,0 x 8 x 152,6  38,0 x 8 x 152,7	A - - RA/S- Cr - RA/S- Cr -	- 20° - - - 36° - VS - - 45° - -	9 - 1 - III 1 - III	A 906 016 07 91 A 906 050 08 27 A 906 050 09 27 A 906 050 03 27 A 906 050 06 27 A 906 050 07 27	<b>50 009 053</b> (1) <b>16210</b>  <b>160057</b>
	(1)	Konstantdrosselventil - flach Exhaust brake valve - flat Soupape de réduction permanente - plate Válvula de reducción permanente - plana Постоянный дроссельный клапан					
	[50]	∅ 8 mm				A 102 053 00 26	<b>RK-8H</b>
Fortsetzung nächste Seite / continued on next page / suite page suivante / continuación página próxima / Продолжение на следующей странице							

					Reference	Item No.
	IN/EX [4] 13,03 x 8 x 60,0 IN/EX [4] 14,03 x 8 x 60,0	G2 G2			A 906 053 01 29 A 906 053 01 30 A 906 053 05 29	<b>81-16105</b> <b>81-16107</b>
	IN [1] 35,08 x 28 x 7,6 IN [1] 35,37 x 28 x 7,7 EX [2] 40,38 x 31 x 8,5  EX [1] 40,08 x 31 x 8,0 EX [1] 40,08 x 31.2 x 8,0	G1 G1 G1 45°  G1 G1			A 906 053 01 31 A 906 053 02 31 A 906 053 02 32 A 906 053 14 32 A 906 053 16 32 A 906 053 01 32 A 906 053 12 32	<b>92-16165</b> <b>92-16159</b> <b>92-16160</b>  <b>92-16167</b> <b>92-16166</b>
	- - - - 	- - - EVB			A 906 010 59 21 A 906 010 72 21	<b>20 0803 90602</b>

**296**
**106**
**OM 926 Euro 5**
**990**

10.2004 →

D (LA)

6

 7201 cm<sup>3</sup> 3V

240 kW

(326 PS) 17:1

136,00 mm

	IN/EX [4] 13,03 x 8 x 60,0 IN/EX [4] 14,03 x 8 x 60,0	G2 G2			A 906 053 01 29 A 906 053 01 30 A 906 053 05 29	<b>81-16105</b> <b>81-16107</b>
	IN [1] 35,08 x 28 x 7,6 IN [1] 35,37 x 28 x 7,7 EX [2] 40,38 x 31 x 8,5  EX [1] 40,08 x 31 x 8,0 EX [1] 40,08 x 31.2 x 8,0	G1 G1 G1 45°  G1 G1			A 906 053 01 31 A 906 053 02 31 A 906 053 02 32 A 906 053 14 32 A 906 053 16 32 A 906 053 01 32 A 906 053 12 32	<b>92-16165</b> <b>92-16159</b> <b>92-16160</b>  <b>92-16167</b> <b>92-16166</b>

**297**
**106**
**OM 924 Euro 5**
**934**

09.2005 → 12.2011

D (LA)

4

 4801 cm<sup>3</sup> 3V

95-150 kW

(129-204 PS)

136,00 mm

**OM 926**
**959**

D (LA)

6

 7201 cm<sup>3</sup> 3V

175-240 kW

(238-326 PS) 17:1

136,00 mm

40 270 6.., 41 003 6..

	IN [2] 34,0 x 8 x 125,9 IN [2] 34,0 x 8 x 128,9	RA/S- Cr - RA/S- Cr -	- 20° - - - 20° - -	1 - III 1 - III	A 906 050 02 26 A 906 050 03 26 A 906 050 06 26 A 906 050 07 26	<b>16200</b> <b>160056</b>
	EX [2] 15,2 x 6 x 81,6 EX [2] 38,0 x 8 x 152,6	A - - RA/S- Cr -	- 20° - - - 36° - VS -	9 - 1 - III	A 906 016 07 91 A 906 050 08 27 A 906 050 09 27	<b>50 009 053</b> (1) <b>16210</b>
	EX [2] 38,0 x 8 x 152,7	RA/S- Cr -	- 45° - -	1 - III	A 906 050 03 27 A 906 050 06 27 A 906 050 07 27	<b>160057</b>
	(1) Konstantdrosselventil - flach Exhaust brake valve - flat Soupape de réduction permanente - plate Válvula de reducción permanente - plana Постоянный дроссельный клапан					
	[50] Ø 8 mm				A 102 053 00 26	<b>RK-8H</b>
	IN [1] 35,08 x 28 x 7,6 EX [1] 40,08 x 31 x 8,0	G1 G1			A 906 053 01 31 A 906 053 16 32	<b>92-16165</b> <b>92-16167</b>

					Reference	Item No.
<b>298</b> <b>106</b> <b>OM 924 Euro 5</b> <b>927, 931</b> 06.2006 →     D (LA) 4 4801 cm <sup>3</sup> 3V     160 kW     (218 PS) 17,4:1     136,00 mm 40 270 6..., 41 003 6..						
	IN [2] IN [2]	34,0 x 8 x 125,9 34,0 x 8 x 128,9	RA/S- Cr - RA/S- Cr -	- 20° - - - 20° - -	1 - III 1 - III	A 906 050 02 26 A 906 050 03 26 A 906 050 06 26 A 906 050 07 26 <b>16200</b> <b>160056</b>
	EX [2] EX [2]	15,2 x 6 x 81,6 38,0 x 8 x 152,6	A - - RA/S- Cr -	- 20° - - - 36° - VS -	9 - 1 - III	A 906 016 07 91 A 906 050 08 27 A 906 050 09 27 <b>50 009 053</b> (1) <b>16210</b>
	EX [2]	38,0 x 8 x 152,7	RA/S- Cr -	- 45° - -	1 - III	A 906 050 03 27 A 906 050 06 27 A 906 050 07 27 <b>160057</b>
	(1) Konstantdrosselventil - flach Exhaust brake valve - flat Soupape de réduction permanente - plate Válvula de reducción permanente - plana Постоянный дроссельный клапан					
	[50]	Ø 8 mm				A 102 053 00 26 <b>RK-8H</b>
	IN/EX [4] IN/EX [4]	13,03 x 8 x 60,0 14,03 x 8 x 60,0	G2 G2			A 906 053 01 29 A 906 053 01 30 A 906 053 05 29 <b>81-16105</b> <b>81-16107</b>
	IN [1] IN [1] EX [2]	35,08 x 28 x 7,6 35,37 x 28 x 7,7 40,38 x 31 x 8,5	G1 G1 G1 45°			A 906 053 01 31 A 906 053 02 31 A 906 053 02 32 A 906 053 14 32 <b>92-16165</b> <small>NEW</small> <b>92-16159</b> <b>92-16160</b>
	EX [1]	40,08 x 31 x 8,0	G1			A 906 053 16 32 <b>92-16167</b> <small>NEW</small>
						A 904 050 04 01 A 904 050 09 01 A 904 050 40 01 <b>20 1003 90400</b>
<b>299</b> <b>106</b> <b>OM 926 Euro 4/5</b> <b>963</b> 2007 →     D (LA) 6 7201 cm <sup>3</sup> 3V     175-240 kW     (238-326 PS) 17,4:1     136,00 mm 40 026 6..., 40 284 6..						
	IN [2] IN [2]	34,0 x 8 x 125,9 34,0 x 8 x 128,9	RA/S- Cr - RA/S- Cr -	- 20° - - - 20° - -	1 - III 1 - III	A 906 050 02 26 A 906 050 03 26 A 906 050 06 26 A 906 050 07 26 <b>16200</b> <b>160056</b>
	EX [2] EX [2]	15,2 x 6 x 81,6 38,0 x 8 x 152,6	A - - RA/S- Cr -	- 20° - - - 36° - VS -	9 - 1 - III	A 906 016 07 91 A 906 050 08 27 A 906 050 09 27 <b>50 009 053</b> (1) <b>16210</b>
	EX [2]	38,0 x 8 x 152,7	RA/S- Cr -	- 45° - -	1 - III	A 906 050 03 27 A 906 050 06 27 A 906 050 07 27 <b>160057</b>
	(1) Konstantdrosselventil - flach Exhaust brake valve - flat Soupape de réduction permanente - plate Válvula de reducción permanente - plana Постоянный дроссельный клапан					
	[50]	Ø 8 mm				A 102 053 00 26 <b>RK-8H</b>
	IN/EX [4] IN/EX [4]	13,03 x 8 x 60,0 14,03 x 8 x 60,0	G2 G2			A 906 053 01 29 A 906 053 01 30 A 906 053 05 29 <b>81-16105</b> <b>81-16107</b>
Fortsetzung nächste Seite / continued on next page / suite page suivante / continuación página próxima / Продолжение на следующей странице						

					Reference	Item No.
	IN [1] 35,08 x 28 x 7,6 IN [1] 35,37 x 28 x 7,7 EX [2] 40,38 x 31 x 8,5	G1 G1 G1 45°			A 906 053 01 31 A 906 053 02 31 A 906 053 02 32 A 906 053 14 32	<b>92-16165</b> <b>92-16159</b> <b>92-16160</b>
	EX [1] 40,08 x 31 x 8,0 EX [1] 40,08 x 31.2 x 8,0	G1 G1			A 906 053 16 32 A 906 053 01 32 A 906 053 12 32	<b>92-16167</b> <b>92-16166</b>
	817,5 mm				A 906 050 09 01 A 906 050 14 01 A 906 050 42 01 A 906 050 26 01	<b>20 1003 90600</b>  <b>20 1003 90601</b>
	[12] M 33 x 18				A 906 054 07 01 A 906 054 10 01	<b>20 1003 90660</b>

**300**

**106**
**OM 924 Euro 3**
**913**

05.2007 →

D (LA) 4

 4801 cm<sup>3</sup> 3V

160 kW

(218 PS) 17,4:1

136,00 mm

40 078 6..

	IN [2] 34,0 x 8 x 125,9 IN [2] 34,0 x 8 x 128,9	RA/S- Cr - RA/S- Cr -	- 20° - - - 20° - -	1 - III 1 - III	A 906 050 02 26 A 906 050 03 26 A 906 050 06 26 A 906 050 07 26	<b>16200</b> <b>160056</b>
	EX [2] 15,2 x 6 x 81,6 EX [2] 38,0 x 8 x 152,6	A - - RA/S- Cr -	- 20° - - - 36° - VS -	9 - 1 - III	A 906 016 07 91 A 906 050 08 27 A 906 050 09 27	<b>50 009 053</b> (1) <b>16210</b>
	EX [2] 38,0 x 8 x 152,7	RA/S- Cr -	- 45° - -	1 - III	A 906 050 03 27 A 906 050 06 27 A 906 050 07 27	<b>160057</b>
	(1) Konstantdrosselventil - flach Exhaust brake valve - flat Soupape de réduction permanente - plate Válvula de reducción permanente - plana Постоянный дроссельный клапан					
	[50] Ø 8 mm				A 102 053 00 26	<b>RK-8H</b>
	IN [1] 35,08 x 28 x 7,6 EX [1] 40,08 x 31 x 8,0 EX [1] 40,08 x 31.2 x 8,0	G1 G1 G1			A 906 053 01 31 A 906 053 16 32 A 906 053 01 32 A 906 053 12 32	<b>92-16165</b> <b>92-16167</b> <b>92-16166</b>
	[12] M 33 x 18				A 906 054 07 01 A 906 054 10 01	<b>20 1003 90660</b>

**301**

**106**
**OM 926 Euro 4/5**
**947**

D (LA) 6

 7201 cm<sup>3</sup> 3V

240 kW

(326 PS) 17:1

136,00 mm

40 270 6.., 41 003 6..

	IN [2] 34,0 x 8 x 125,9 IN [2] 34,0 x 8 x 128,9	RA/S- Cr - RA/S- Cr -	- 20° - - - 20° - -	1 - III 1 - III	A 906 050 02 26 A 906 050 03 26 A 906 050 06 26 A 906 050 07 26	<b>16200</b> <b>160056</b>
	EX [2] 15,2 x 6 x 81,6 EX [2] 38,0 x 8 x 152,6	A - - RA/S- Cr -	- 20° - - - 36° - VS -	9 - 1 - III	A 906 016 07 91 A 906 050 08 27 A 906 050 09 27	<b>50 009 053</b> (1) <b>16210</b>
	EX [2] 38,0 x 8 x 152,7	RA/S- Cr -	- 45° - -	1 - III	A 906 050 03 27 A 906 050 06 27 A 906 050 07 27	<b>160057</b>

Fortsetzung nächste Seite / continued on next page / suite page suivante / continuación página próxima / Продолжение на следующей странице



					Reference	Item No.
(1)	Konstantdrosselventil - flach Exhaust brake valve - flat Soupape de réduction permanente - plate Válvula de reducción permanente - plana Постоянный дроссельный клапан					
[50]	Ø 8 mm				A 102 053 00 26	<b>RK-8H</b>
IN/EX [4] IN/EX [4]	13,03 x 8 x 60,0 14,03 x 8 x 60,0	G2 G2			A 906 053 01 29 A 906 053 01 30 A 906 053 05 29	<b>81-16105</b> <b>81-16107</b>
IN [1] IN [1] EX [2]  EX [1]	35,08 x 28 x 7,6 35,37 x 28 x 7,7 40,38 x 31 x 8,5  40,08 x 31 x 8,0	G1 G1 G1 45°  G1			A 906 053 01 31 A 906 053 02 31 A 906 053 02 32 A 906 053 14 32 A 906 053 16 32	<b>92-16165</b> <small>NEW</small> <b>92-16159</b> <b>92-16160</b>  <b>92-16167</b> <small>NEW</small>
	- - - -	- - - - EVB			A 906 010 59 21 A 906 010 72 21	<b>20 0803 90602</b>



M

**302** **106**

OM 924 Euro 5

932

D (LA) 4 4801 cm<sup>3</sup> 3V 145 kW (197 PS) 17,4:1 136,00 mm

40 078 6..

IN [2] IN [2]	34,0 x 8 x 125,9 34,0 x 8 x 128,9	RA/S- Cr - RA/S- Cr -	- 20° - - - 20° - -	1 - III 1 - III	A 906 050 02 26 A 906 050 03 26 A 906 050 06 26 A 906 050 07 26	<b>16200</b> <b>160056</b>
EX [2] EX [2]	15,2 x 6 x 81,6 38,0 x 8 x 152,6	A - - RA/S- Cr -	- 20° - - - 36° - VS -	9 - 1 - III	A 906 016 07 91 A 906 050 08 27 A 906 050 09 27	<b>50 009 053</b> (1) <b>16210</b>
EX [2]	38,0 x 8 x 152,7	RA/S- Cr -	- 45° - -	1 - III	A 906 050 03 27 A 906 050 06 27 A 906 050 07 27	<b>160057</b>
(1)	Konstantdrosselventil - flach Exhaust brake valve - flat Soupape de réduction permanente - plate Válvula de reducción permanente - plana Постоянный дроссельный клапан					
[50]	Ø 8 mm				A 102 053 00 26	<b>RK-8H</b>
IN/EX [4] IN/EX [4]	13,03 x 8 x 60,0 14,03 x 8 x 60,0	G2 G2			A 906 053 01 29 A 906 053 01 30 A 906 053 05 29	<b>81-16105</b> <b>81-16107</b>
IN [1] IN [1] EX [2]  EX [1]	35,08 x 28 x 7,6 35,37 x 28 x 7,7 40,38 x 31 x 8,5  40,08 x 31 x 8,0	G1 G1 G1 45°  G1			A 906 053 01 31 A 906 053 02 31 A 906 053 02 32 A 906 053 14 32 A 906 053 16 32	<b>92-16165</b> <small>NEW</small> <b>92-16159</b> <b>92-16160</b>  <b>92-16167</b> <small>NEW</small>

					Reference	Item No.	
<b>303</b>		<b>106</b>					
<b>OM 924</b>	<b>986</b>	D (LA) 4		4801 cm <sup>3</sup> 3V	160 kW (218 PS)	136,00 mm	
<b>OM 926 Euro 3</b>	<b>951</b>	D (LA) 6		7201 cm <sup>3</sup> 3V	225 kW (306 PS) 17:1	136,00 mm	
40 078 6..							
	IN [2]	34,0 x 8 x 128,9	RA/S- Cr -	- 20° - -	1 - III	A 906 050 03 26 A 906 050 06 26 A 906 050 07 26 <b>160056</b>	
	EX [2]	38,0 x 8 x 152,6	RA/S- Cr -	- 36° - VS -	1 - III	A 906 050 08 27 A 906 050 09 27 <b>16210</b>	
	[50]	Ø 8 mm				A 102 053 00 26 <b>RK-8H</b>	
	[12]	M 33 x 18				A 906 054 07 01 A 906 054 10 01 <b>20 1003 90660</b>	
<b>304</b>		<b>106</b>					
<b>OM 926 Euro 3</b>	<b>925</b>	D (LA) 6		7201 cm <sup>3</sup> 3V	215-220 kW (292-299 PS) 17:1	136,00 mm	
	IN [2]	34,0 x 8 x 125,9	RA/S- Cr -	- 20° - -	1 - III	A 906 050 02 26 <b>16200</b>	
	IN [2]	34,0 x 8 x 128,9	RA/S- Cr -	- 20° - -	1 - III	A 906 050 03 26 A 906 050 06 26 A 906 050 07 26 <b>160056</b>	
	EX [2]	15,2 x 6 x 81,6	A - -	- 20° - -	9 -	A 906 016 07 91 <b>50 009 053 (1)</b>	
	EX [2]	38,0 x 8 x 152,6	RA/S- Cr -	- 36° - VS -	1 - III	A 906 050 08 27 A 906 050 09 27 <b>16210</b>	
	EX [2]	38,0 x 8 x 152,7	RA/S- Cr -	- 45° - -	1 - III	A 906 050 03 27 A 906 050 06 27 A 906 050 07 27 <b>160057</b>	
	(1)	Konstantdrosselventil - flach Exhaust brake valve - flat Soupape de réduction permanente - plate Válvula de reducción permanente - plana Постоянный дроссельный клапан					
	[50]	Ø 8 mm				A 102 053 00 26 <b>RK-8H</b>	
	IN/EX [4]	13,03 x 8 x 60,0	G2			A 906 053 01 29 <b>81-16105</b>	
	IN/EX [4]	14,03 x 8 x 60,0	G2			A 906 053 01 30 A 906 053 05 29 <b>81-16107</b>	
	IN [1]	35,08 x 28 x 7,6	G1			A 906 053 01 31 <b>92-16165 NEW</b>	
	IN [1]	35,37 x 28 x 7,7	G1			A 906 053 02 31 <b>92-16159</b>	
	EX [2]	40,38 x 31 x 8,5	G1 45°			A 906 053 02 32 A 906 053 14 32 <b>92-16160</b>	
	EX [1]	40,08 x 31 x 8,0	G1			A 906 053 16 32 <b>92-16167 NEW</b>	
	EX [1]	40,08 x 31.2 x 8,0	G1			A 906 053 01 32 A 906 053 12 32 <b>92-16166 NEW</b>	
		817,5 mm				A 906 050 09 01 A 906 050 14 01 A 906 050 42 01 <b>20 1003 90600</b>	
		818,5 mm				A 906 050 26 01 <b>20 1003 90601 NEW</b>	
Fortsetzung nächste Seite / continued on next page / suite page suivante / continuación página próxima / Продолжение на следующей странице							

M

					Reference	Item No.
	- - - -	- - - EVB			A 906 010 59 21 A 906 010 72 21	<b>20 0803 90602</b>

## 305 106

OM 926 Euro 3

929

D (LA) 6 7201 cm<sup>3</sup> 3V 220-240 kW (299-326 PS) 17:1 136,00 mm

40 078 6..

	IN [2]	34,0 x 8 x 125,9	RA/S- Cr -	- 20° - -	1 - III	A 906 050 02 26	<b>16200</b>	
	IN [2]	34,0 x 8 x 128,9	RA/S- Cr -	- 20° - -	1 - III	A 906 050 03 26 A 906 050 06 26 A 906 050 07 26	<b>160056</b>	
	EX [2]	15,2 x 6 x 81,6	A - -	- 20° - -	9 -	A 906 016 07 91	<b>50 009 053</b> (1)	
	EX [2]	38,0 x 8 x 152,6	RA/S- Cr -	- 36° - VS -	1 - III	A 906 050 08 27 A 906 050 09 27	<b>16210</b>	
	EX [2]	38,0 x 8 x 152,7	RA/S- Cr -	- 45° - -	1 - III	A 906 050 03 27 A 906 050 06 27 A 906 050 07 27	<b>160057</b>	
	(1)	Konstantdrosselventil - flach Exhaust brake valve - flat Soupape de réduction permanente - plate Válvula de reducción permanente - plana Постоянный дроссельный клапан						
	[50]	Ø 8 mm				A 102 053 00 26	<b>RK-8H</b>	
	IN/EX [4]	13,03 x 8 x 60,0	G2			A 906 053 01 29	<b>81-16105</b>	
	IN/EX [4]	14,03 x 8 x 60,0	G2			A 906 053 01 30 A 906 053 05 29	<b>81-16107</b>	
	IN [1]	35,08 x 28 x 7,6	G1			A 906 053 01 31	<b>92-16165</b> <small>NEW</small>	
	IN [1]	35,37 x 28 x 7,7	G1			A 906 053 02 31	<b>92-16159</b>	
	EX [2]	40,38 x 31 x 8,5	G1 45°			A 906 053 02 32 A 906 053 14 32	<b>92-16160</b>	
	EX [1]	40,08 x 31 x 8,0	G1			A 906 053 16 32	<b>92-16167</b> <small>NEW</small>	
						A 906 050 32 01 A 906 050 40 01	<b>20 1003 90605</b>	
	[12]	M 33 x 18				A 906 054 07 01 A 906 054 10 01	<b>20 1003 90660</b>	
		- - - -	- - - EVB			A 906 010 59 21 A 906 010 72 21	<b>20 0803 90602</b>	

## 306 106

OM 926 Euro 3

933

D (LA) 6 7201 cm<sup>3</sup> 3V 225 kW (306 PS) 17:1 136,00 mm

40 078 6..

	IN/EX [4]	13,03 x 8 x 60,0	G2			A 906 053 01 29	<b>81-16105</b>
	IN/EX [4]	14,03 x 8 x 60,0	G2			A 906 053 01 30 A 906 053 05 29	<b>81-16107</b>

					Reference	Item No.
	IN [1] 35,08 x 28 x 7,6 IN [1] 35,37 x 28 x 7,7 EX [2] 40,38 x 31 x 8,5	G1 G1 G1 45°			A 906 053 01 31 A 906 053 02 31 A 906 053 02 32 A 906 053 14 32 A 906 053 16 32 A 906 053 01 32 A 906 053 12 32	92-16165 92-16159 92-16160  92-16167 92-16166
	[12] M 33 x 18				A 906 054 07 01 A 906 054 10 01	20 1003 90660
	- - - - 	- - - EVB			A 906 010 59 21 A 906 010 72 21	20 0803 90602

**307**
**106**
**OM 926 Euro 3**
**938**

D (LA) 6 7201 cm<sup>3</sup> 3V 205 kW (279 PS) 17:1 136,00 mm

40 078 6..

	IN [2] 34,0 x 8 x 125,9 IN [2] 34,0 x 8 x 128,9	RA/S- Cr - RA/S- Cr -	- 20° - - - 20° - -	1 - III 1 - III	A 906 050 02 26 A 906 050 03 26 A 906 050 06 26 A 906 050 07 26	16200 160056
	EX [2] 15,2 x 6 x 81,6 EX [2] 38,0 x 8 x 152,6	A - - RA/S- Cr -	- 20° - - - 36° - VS -	9 - 1 - III	A 906 016 07 91 A 906 050 08 27 A 906 050 09 27	50 009 053 (1) 16210
	EX [2] 38,0 x 8 x 152,7	RA/S- Cr -	- 45° - -	1 - III	A 906 050 03 27 A 906 050 06 27 A 906 050 07 27	160057
	(1) Konstantdrosselventil - flach Exhaust brake valve - flat Soupape de réduction permanente - plate Válvula de reducción permanente - plana Постоянный дроссельный клапан					
	[50] Ø 8 mm				A 102 053 00 26	RK-8H
	IN/EX [4] 13,03 x 8 x 60,0 IN/EX [4] 14,03 x 8 x 60,0	G2 G2			A 906 053 01 29 A 906 053 01 30 A 906 053 05 29	81-16105 81-16107
	IN [1] 35,08 x 28 x 7,6 IN [1] 35,37 x 28 x 7,7 EX [2] 40,38 x 31 x 8,5	G1 G1 G1 45°			A 906 053 01 31 A 906 053 02 31 A 906 053 02 32 A 906 053 14 32 A 906 053 16 32 A 906 053 01 32 A 906 053 12 32	92-16165 92-16159 92-16160  92-16167 92-16166
	818,5 mm				A 906 050 26 01	20 1003 90601
	[12] M 33 x 18				A 906 054 07 01 A 906 054 10 01	20 1003 90660

Fortsetzung nächste Seite / continued on next page / suite page suivante / continuación página próxima / Продолжение на следующей странице

					Reference	Item No.
	- - - -	- - - EVB			A 906 010 59 21 A 906 010 72 21	<b>20 0803 90602</b>

## 308 106

OM 926 Euro 3

940

D (LA) 6 7201 cm<sup>3</sup> 3V 220-240 kW (299-326 PS) 17:1 136,00 mm

40 078 6..

	IN [2] IN [2]	34,0 x 8 x 125,9 34,0 x 8 x 128,9	RA/S- Cr - RA/S- Cr -	- 20° - - - 20° - -	1 - III 1 - III	A 906 050 02 26 A 906 050 03 26 A 906 050 06 26 A 906 050 07 26	<b>16200</b> <b>160056</b>
	EX [2] EX [2]	15,2 x 6 x 81,6 38,0 x 8 x 152,6	A - - RA/S- Cr -	- 20° - - - 36° - VS -	9 - 1 - III	A 906 016 07 91 A 906 050 08 27 A 906 050 09 27	<b>50 009 053</b> (1) <b>16210</b>
	EX [2]	38,0 x 8 x 152,7	RA/S- Cr -	- 45° - -	1 - III	A 906 050 03 27 A 906 050 06 27 A 906 050 07 27	<b>160057</b>
	(1) Konstantdrosselventil - flach Exhaust brake valve - flat Soupape de réduction permanente - plate Válvula de reducción permanente - plana Постоянный дроссельный клапан						
	[50]	Ø 8 mm				A 102 053 00 26	<b>RK-8H</b>
	IN/EX [4] IN/EX [4]	13,03 x 8 x 60,0 14,03 x 8 x 60,0	G2 G2			A 906 053 01 29 A 906 053 01 30 A 906 053 05 29	<b>81-16105</b> <b>81-16107</b>
	IN [1] IN [1] EX [2]	35,08 x 28 x 7,6 35,37 x 28 x 7,7 40,38 x 31 x 8,5	G1 G1 G1 45°			A 906 053 01 31 A 906 053 02 31 A 906 053 02 32 A 906 053 14 32	<b>92-16165</b> <small>NEW</small> <b>92-16159</b> <b>92-16160</b>
	EX [1]	40,08 x 31 x 8,0	G1			A 906 053 16 32	<b>92-16167</b> <small>NEW</small>
		818,5 mm				A 906 050 26 01 A 906 050 32 01 A 906 050 40 01	<b>20 1003 90601</b> <small>NEW</small> <b>20 1003 90605</b>
	[12]	M 33 x 18				A 906 054 07 01 A 906 054 10 01	<b>20 1003 90660</b>
		- - - -	- - - EVB			A 906 010 59 21 A 906 010 72 21	<b>20 0803 90602</b>

## 309 106

OM 926 Euro 3

944

D (LA) 6 7201 cm<sup>3</sup> 3V 175-240 kW (238-326 PS) 136,00 mm

	IN/EX [4] IN/EX [4]	13,03 x 8 x 60,0 14,03 x 8 x 60,0	G2 G2			A 906 053 01 29 A 906 053 01 30 A 906 053 05 29	<b>81-16105</b> <b>81-16107</b>
--	------------------------	--------------------------------------	----------	--	--	---	------------------------------------

Fortsetzung nächste Seite / continued on next page / suite page suivante / continuación página próxima / Продолжение на следующей странице



					Reference	Item No.
	IN [1] IN [1] EX [2]	35,08 x 28 x 7,6 35,37 x 28 x 7,7 40,38 x 31 x 8,5	G1 G1 G1 45°		A 906 053 01 31 A 906 053 02 31 A 906 053 02 32 A 906 053 14 32	<b>92-16165</b> <small>NEW</small> <b>92-16159</b> <b>92-16160</b>
	EX [1] EX [1]	40,08 x 31 x 8,0 40,08 x 31.2 x 8,0	G1 G1		A 906 053 16 32 A 906 053 01 32 A 906 053 12 32	<b>92-16167</b> <small>NEW</small> <b>92-16166</b> <small>NEW</small>
	[12]	M 33 x 18			A 906 054 07 01 A 906 054 10 01	<b>20 1003 90660</b>

## 310 106

OM 926 Euro 5

946

D (LA) 6 7201 cm<sup>3</sup> 3V 210-240 kW (286-326 PS) 17:1 136,00 mm

40 270 6.., 41 003 6..

	IN [2]  EX [2]  EX [2]	34,0 x 8 x 128,9  38,0 x 8 x 152,6  38,0 x 8 x 152,7	RA/S- Cr -  RA/S- Cr -  RA/S- Cr -	- 20° - -  - 36° - VS -  - 45° - -	1 - III  1 - III  1 - III	A 906 050 03 26 A 906 050 06 26 A 906 050 07 26 A 906 050 08 27 A 906 050 09 27 A 906 050 03 27 A 906 050 06 27 A 906 050 07 27	<b>160056</b>  <b>16210</b>  <b>160057</b>
	[50]	Ø 8 mm				A 102 053 00 26	<b>RK-8H</b>
	IN/EX [4] IN/EX [4]	13,03 x 8 x 60,0 14,03 x 8 x 60,0	G2 G2			A 906 053 01 29 A 906 053 01 30 A 906 053 05 29	<b>81-16105</b> <b>81-16107</b>
	IN [1] IN [1] EX [2]  EX [1] EX [1]	35,08 x 28 x 7,6 35,37 x 28 x 7,7 40,38 x 31 x 8,5  40,08 x 31 x 8,0 40,08 x 31.2 x 8,0	G1 G1 G1 45°  G1 G1			A 906 053 01 31 A 906 053 02 31 A 906 053 02 32 A 906 053 14 32 A 906 053 16 32 A 906 053 01 32 A 906 053 12 32	<b>92-16165</b> <small>NEW</small> <b>92-16159</b> <b>92-16160</b>  <b>92-16167</b> <small>NEW</small> <b>92-16166</b> <small>NEW</small>
		- - - -	- - - EVB			A 906 010 59 21 A 906 010 72 21	<b>20 0803 90602</b>

## 311 106

OM 926 Euro 4

949

D (LA) 6 7201 cm<sup>3</sup> 3V 210 kW (286 PS) 17:1 136,00 mm

40 270 6..

	IN/EX [4] IN/EX [4]	13,03 x 8 x 60,0 14,03 x 8 x 60,0	G2 G2			A 906 053 01 29 A 906 053 01 30 A 906 053 05 29	<b>81-16105</b> <b>81-16107</b>
	IN [1] IN [1] EX [2]  EX [1]	35,08 x 28 x 7,6 35,37 x 28 x 7,7 40,38 x 31 x 8,5  40,08 x 31 x 8,0	G1 G1 G1 45°  G1			A 906 053 01 31 A 906 053 02 31 A 906 053 02 32 A 906 053 14 32 A 906 053 16 32	<b>92-16165</b> <small>NEW</small> <b>92-16159</b> <b>92-16160</b>  <b>92-16167</b> <small>NEW</small>

Fortsetzung nächste Seite / continued on next page / suite page suivante / continuación página próxima / Продолжение на следующей странице

					Reference	Item No.
	817,5 mm				A 906 050 09 01 A 906 050 14 01 A 906 050 42 01	20 1003 90600
	818,5 mm				A 906 050 26 01	20 1003 90601 <b>NEW</b>
	- - - -	- - - EVB			A 906 010 59 21 A 906 010 72 21	20 0803 90602

## 312

OM 926 Euro 4/5 968

D (LA) 6 7201 cm<sup>3</sup> 3V 225 kW (306 PS) 136,00 mm

40 078 6..

	IN [2]	34,0 x 8 x 128,9	RA/S- Cr -	- 20° - -	1 - III	A 906 050 03 26 A 906 050 06 26 A 906 050 07 26	160056
	EX [2]	38,0 x 8 x 152,6	RA/S- Cr -	- 36° - VS -	1 - III	A 906 050 08 27 A 906 050 09 27	16210
	[50]	Ø 8 mm				A 102 053 00 26	RK-8H
	IN [1] EX [1]	35,08 x 28 x 7,6 40,08 x 31 x 8,0	G1 G1			A 906 053 01 31 A 906 053 16 32	92-16165 <b>NEW</b> 92-16167 <b>NEW</b>
	[12]	M 33 x 18				A 906 054 07 01 A 906 054 10 01	20 1003 90660

## 313

OM 926 Euro 4/5 969

D (LA) 6 7201 cm<sup>3</sup> 3V 225-240 kW (306-326 PS) 136,00 mm

40 078 6..

	IN [2]	34,0 x 8 x 128,9	RA/S- Cr -	- 20° - -	1 - III	A 906 050 03 26 A 906 050 06 26 A 906 050 07 26	160056
	EX [2]	38,0 x 8 x 152,6	RA/S- Cr -	- 36° - VS -	1 - III	A 906 050 08 27 A 906 050 09 27	16210
	[50]	Ø 8 mm				A 102 053 00 26	RK-8H
	IN/EX [4] IN/EX [4]	13,03 x 8 x 60,0 14,03 x 8 x 60,0	G2 G2			A 906 053 01 29 A 906 053 01 30 A 906 053 05 29	81-16105 81-16107
	IN [1] IN [1] EX [2]	35,08 x 28 x 7,6 35,37 x 28 x 7,7 40,38 x 31 x 8,5	G1 G1 G1 45°			A 906 053 01 31 A 906 053 02 31 A 906 053 02 32 A 906 053 14 32	92-16165 <b>NEW</b> 92-16159 92-16160
	EX [1] EX [1]	40,08 x 31 x 8,0 40,08 x 31.2 x 8,0	G1 G1			A 906 053 16 32 A 906 053 01 32 A 906 053 12 32	92-16167 <b>NEW</b> 92-16166 <b>NEW</b>
	[12]	M 33 x 18				A 906 054 07 01 A 906 054 10 01	20 1003 90660

					Reference	Item No.	
<b>314</b>	<b>106</b>	<b>OM 926 Euro 3 985 - 986</b>					
40 078 6..							
D (LA) 6 7201 cm <sup>3</sup> 3V 175-247 kW (238-336 PS) 17:1 136,00 mm							
	[12]	M 33 x 18			A 906 054 07 01 A 906 054 10 01	<b>20 1003 90660</b>	
<b>315</b>	<b>110</b>	<b>CO 3 D VAR.1 08.1973 → 12.1980</b>					
D (NA) 4 4940 cm <sup>3</sup> 2V 63 kW (86 PS) 17,2:1 130,00 mm							
	IN [1]	59,0 x 12 x 142,5	A/S - Cr -	- 30° -	5 - III	A 403 053 09 01 A 422 050 00 26 A 422 050 02 26 A 422 050 05 26 A 422 053 01 01 A 423 050 00 26 A 442 050 02 26 A 442 050 03 26	<b>16117</b>
	IN [1]	59,0 x 12 x 142,5	A/S - Cr -	- 30° -	5 - III	A 442 050 05 26	<b>16146</b>
	IN [1]	59,0 x 12 x 142,5	S - Cr -	- 30° - VS -	5 - III	A 423 050 00 26	<b>1606</b>
	EX [1]	51,0 x 12 x 142,5	A/S - Cr -	- 45° -	5 - III	A 422 050 00 27	<b>16116</b>
	EX [1]	51,0 x 12 x 142,5	RA/S- Cr -	- 45° -	5 - III	A 422 050 01 27 A 422 050 02 27 A 442 050 01 27 A 442 050 02 27 A 442 050 03 27 A 442 050 04 27	<b>16150</b>
	EX [1]	51,1 x 12 x 142,5	A/S - Cr -	- 45° -	5 - III	A 423 050 04 27	<b>1608</b>
	[50]					A 000 053 04 26	<b>LK-1605</b>
	[50]	Ø 12 mm				A 422 053 00 26	<b>LK-1610</b>
	IN/EX [6]	18,03 x 12 x 67,0	G1			A 403 053 00 30	<b>81-1647</b>
	IN/EX [6]	18,03 x 12 x 67,0	G2			A 422 053 04 30	<b>81-16100</b>
	IN/EX [6]	18,23 x 12 x 67,0	G1			A 403 053 01 30	<b>81-1648</b>
	IN [2]	60,11 x 51 x 8,9	G1 30°			A 403 053 09 31 A 403 053 15 31	<b>92-16100</b>
	IN [2]	61,11 x 51 x 9,0	G1 30°			A 403 053 03 31	<b>92-16163</b>
	IN [1]	60,31 x 51 x 9,1	G1 30°			A 403 053 10 31	<b>92-16147</b>
	IN [1]	60,51 x 51 x 9,3	G1 30°			A 403 053 11 31	<b>92-16101</b>
	EX [2]	53,11 x 43 x 9,7	G1 45°			A 403 053 00 32 A 403 053 03 32 A 403 053 21 32 A 403 053 25 32 A 403 053 28 32	<b>92-16104</b>
	EX [1]	53,31 x 43 x 9,9	G1 45°			A 403 053 01 32 A 403 053 13 32 A 403 053 22 32 A 403 053 26 32 A 403 053 29 32	<b>92-16148</b>
	EX [1]	53,51 x 43 x 10,2	G1 45°			A 403 053 02 32 A 403 053 23 32 A 403 053 27 32 A 403 053 30 32	<b>92-16105</b>
		724 mm				A 402 050 11 01 A 402 050 13 01 A 402 050 16 01 A 402 050 18 01	<b>20 1003 40200</b>
Fortsetzung nächste Seite / continued on next page / suite page suivante / continuación página próxima / Продолжение на следующей странице							

M

					Reference	Item No.
[12]	M 31,5 x 76,5 x 20				A 403 054 09 01 A 403 054 18 01	<b>20 1003 40060</b>
[12]	M 32 x 76 x 20				A 422 050 03 25 A 476 050 00 25	<b>20 1003 44000</b> (1)
[12]	M 32 x 76 x 20				A 422 050 03 25 A 476 050 00 25	<b>20 1003 44001</b> <span style="border: 1px solid black; padding: 1px;">NEW</span> (2)
(1) OES specification						
(2) IAM specification						
[4]					A 403 050 07 33 A 442 050 03 33	<b>20 1002 25010</b> (3)
[1]					A 403 050 03 33 A 403 050 07 33 A 442 050 03 33	<b>20 1003 40010</b>
[1]					A 403 050 03 33 A 403 050 07 33 A 442 050 03 33 A 442 055 00 20	<b>20 1003 40012</b> (4)
(3) nur 2-Ventiler/only 2 valves version/seulement 2 soupapes/sólo sistemas de 2 válvulas/заменяемо 2 Клапаны						
(4) mit Einstellschraube/with adjusting screw/avec vis de réglage/con tornillo de ajuste/c установочным ВИНТОМ						
	- - G - S -	- - - -			A 402 010 03 20 A 403 010 40 20 A 403 010 89 20 A 427 010 00 20 A 427 010 10 20 A 429 010 02 20 A 442 010 07 20	<b>20 0803 40300</b>
	- V - G - S -	- - - -	ready-to-install		A 427 010 10 20	<b>20 0803 40301</b>

## 316

OM 936 Euro 6

910, 912, 915 - 916, 971 - 973, 975, 977

09.2008 →

D (LA)

6

7698 cm<sup>3</sup> 4V

175-260 kW

(238-354 PS)

135,00 mm

41 276 6..

IN [2]	37,5 x 8 x 193,7	RA/S- Cr -	- 20° -	-	9 - III	A 936 050 00 26 A 936 050 01 26	<b>16213</b>
EX [2]	33,7 x 8 x 199,4	RA/S- Cr -	- 35° -	-	9 - III	A 936 050 00 27	<b>16215</b>
[50]	Ø 9 mm					A 115 053 00 26	<b>RK-9H</b>
	ES					A 936 050 10 01	<b>20 1003 93600</b>

## 317

OM 934 Euro 6

911, 913, 971 - 972, 974, 976, 978

01.2010 →

D (LA)

4

5132 cm<sup>3</sup> 4V

115-170 kW

(156-231 PS)

135,00 mm

41 276 6..

Fortsatzung nächste Seite / continued on next page / suite page suivante / continuación página próxima / Продолжение на следующей странице

					Reference	Item No.
IN [2]	37,5 x 8 x 193,7	RA/S- Cr -	- 20° - -	9 - III	A 936 050 00 26 A 936 050 01 26	<b>16213</b>
EX [2]	33,7 x 8 x 199,4	RA/S- Cr -	- 35° - -	9 - III	A 936 050 00 27	<b>16215</b>
[50]	Ø 9 mm				A 115 053 00 26	<b>RK-9H</b>
	ES				A 934 050 00 01	<b>20 1003 93400</b>

## 318

<b>OM 934 Euro 6</b>	<b>912, 914</b>	D (LA)	4	5132 cm <sup>3</sup>	4V	115-170 kW	(156-231 PS)	17,6	135,00 mm
<b>OM 936 Euro 6</b>	<b>913, 917, 919, 980</b>	D (LA)	6	7698 cm <sup>3</sup>	4V	175-260 kW	(238-354 PS)	17,0:1	135,00 mm
41 276 6..									

IN [2]	37,5 x 8 x 193,7	RA/S- Cr -	- 20° - -	9 - III	A 936 050 00 26 A 936 050 01 26	<b>16213</b>
EX [2]	33,7 x 8 x 199,4	RA/S- Cr -	- 35° - -	9 - III	A 936 050 00 27	<b>16215</b>
[50]	Ø 9 mm				A 115 053 00 26	<b>RK-9H</b>

## 319

<b>OM 935 Euro 6</b>	<b>911 - 912, 915 - 916, 951 - 954</b>	D (LA)	6	7698 cm <sup>3</sup>	4V	175-260 kW	(238-354 PS)	17,6	135,00 mm
<b>OM 936 Euro 6</b>	<b>923, 974</b>	D (LA)	6	7698 cm <sup>3</sup>	4V	175-260 kW	(238-354 PS)		135,00 mm
02.2013 →									

	ES				A 936 050 10 01	<b>20 1003 93600</b>
--	----	--	--	--	-----------------	----------------------

## 320

<b>OM 933 Euro 6</b>	<b>911 - 912, 917 - 918, 951 - 954</b>	D (LA)	4	5132 cm <sup>3</sup>	4V	115-170 kW	(156-231 PS)	17,6	135,00 mm
----------------------	--	--------	---	----------------------	----	------------	--------------	------	-----------

	ES				A 934 050 00 01	<b>20 1003 93400</b>
--	----	--	--	--	-----------------	----------------------

## 321

<b>OM 327</b>	<b>930</b>	D	6	7980 cm <sup>3</sup>	2V				128,00 mm
1965 → 1968									
<b>OM 327</b>	<b>910, 914 - 919, 931 - 946</b>	D (NA)	6	7980 cm <sup>3</sup>	2V	110-125 kW	(150-170 PS)	17:1	128,00 mm
1965 →									
<b>OM 360</b>	<b>910 - 911</b>	D (LA)	6	8720 cm <sup>3</sup>	2V	125-141 kW	(170-192 PS)	16,8:1	140,00 mm
01.1979 →									
<b>OM 360</b>	<b>912, 914 - 918, 931, 933 - 944, 946 - 952, 954 - 956, 959 - 976, 978 - 981</b>	D (NA)	6		2V	81-141 kW	(110-192 PS)	16,8:1	140,00 mm
1968 →									
<b>OM 360</b>	<b>982 - 986</b>	D (A)	6	8720 cm <sup>3</sup>	2V	125-154 kW	(170-210 PS)	16,8:1	140,00 mm
05.1969 →									
<b>OM 360</b>	<b>930, 977</b>	D	6	8725 cm <sup>3</sup>	2V	125 kW	(170 PS)		140,00 mm
01.1979 →									
93 508 6..									

IN [2]	54,0 x 10 x 150,0	S - Cr -	- 45° - VS -	5 - III	A 327 053 07 01 A 360 050 03 26	<b>1659</b>
EX [2]	43,0 x 10 x 150,0	A/S - Cr -	- 45° - -	5 -	A 360 050 01 27 A 360 050 02 27	<b>1610</b>
IN [6]	16,00 x 10 x 79,0	G1			A 360 053 00 29	<b>81-1650</b>
IN [6]	16,00 x 10 x 85,0	G1			A 327 053 08 30	<b>81-1638</b>
EX [6]	16,00 x 10 x 71,0	G1			A 360 053 00 30	<b>81-1654</b>
EX [6]	16,00 x 10 x 77,0	G1			A 327 053 14 30	<b>81-1639</b>

Fortsetzung nächste Seite / continued on next page / suite page suivante / continuación página próxima / Продолжение на следующей странице



					Reference	Item No.
IN [1]	56,01 x 45 x 10,5	G1 45°			A 327 053 03 31 A 360 053 06 31	<b>92-16132</b>
IN [1]	56,11 x 45 x 10,5	G1 45°			A 327 053 04 31 A 360 053 07 31	<b>92-16134</b>
IN [1]	56,21 x 45 x 10,5	G1 45°			A 327 053 05 31 A 360 053 08 31	<b>92-16136</b>
EX [1]	46,01 x 36 x 10,0	G1 45°			A 327 053 03 32 A 360 053 01 32	<b>92-16133</b>
EX [1]	46,11 x 36 x 10,0	G1 45°			A 327 053 04 32 A 360 053 02 32	<b>92-16135</b>
EX [1]	46,21 x 36 x 10,0	G1 45°			A 327 053 05 32 A 360 053 03 32	<b>92-16137</b>

**322**
**125**
**OM 407**
**930 - 932**

09.1967 →

 D (NA) 6 11413 cm<sup>3</sup> 2V

162 kW

(220 PS) 16,5:1 155,00 mm

93 298 6..

IN [1]	59,0 x 12 x 142,5	A/S - Cr -	- 30° - -	5 - III	A 403 053 09 01 A 422 050 00 26 A 422 050 02 26 A 422 050 05 26 A 422 053 01 01 A 423 050 00 26 A 442 050 02 26 A 442 050 03 26	<b>16117</b>
IN [1]	59,0 x 12 x 142,5	A/S - Cr -	- 30° - -	5 - III	A 442 050 05 26	<b>16146</b>
IN [1]	59,0 x 12 x 142,5	S - Cr -	- 30° - VS -	5 - III	A 423 050 00 26	<b>1606</b>
EX [1]	51,0 x 12 x 142,5	A/S - Cr -	- 45° - -	5 - III	A 422 050 00 27	<b>16116</b>
EX [1]	51,0 x 12 x 142,5	RA/S- Cr -	- 45° - -	5 - III	A 422 050 01 27 A 422 050 02 27 A 442 050 01 27 A 442 050 02 27 A 442 050 03 27 A 442 050 04 27	<b>16150</b>
EX [1]	51,1 x 12 x 142,5	A/S - Cr -	- 45° - -	5 - III	A 423 050 04 27	<b>1608</b>
[50]					A 000 053 04 26	<b>LK-1605</b>
[50]	∅ 12 mm				A 422 053 00 26	<b>LK-1610</b>
IN/EX [6]	18,03 x 12 x 67,0	G1			A 403 053 00 30	<b>81-1647</b>
IN/EX [6]	18,03 x 12 x 67,0	G2			A 422 053 04 30	<b>81-16100</b>
IN/EX [6]	18,23 x 12 x 67,0	G1			A 403 053 01 30	<b>81-1648</b>
IN [2]	60,11 x 51 x 8,9	G1 30°			A 403 053 09 31 A 403 053 15 31	<b>92-16100</b>
IN [1]	60,31 x 51 x 9,1	G1 30°			A 403 053 10 31	<b>92-16147</b>
IN [1]	60,51 x 51 x 9,3	G1 30°			A 403 053 11 31	<b>92-16101</b>
EX [2]	53,11 x 43 x 9,7	G1 45°			A 403 053 00 32 A 403 053 03 32 A 403 053 21 32 A 403 053 25 32 A 403 053 28 32	<b>92-16104</b>
EX [1]	53,31 x 43 x 9,9	G1 45°			A 403 053 01 32 A 403 053 13 32 A 403 053 22 32 A 403 053 26 32 A 403 053 29 32	<b>92-16148</b>
EX [1]	53,51 x 43 x 10,2	G1 45°			A 403 053 02 32 A 403 053 23 32 A 403 053 27 32 A 403 053 30 32	<b>92-16105</b>

Fortsetzung nächste Seite / continued on next page / suite page suivante / continuación página próxima / Продолжение на следующей странице

					Reference	Item No.
	- - G - S -	- - - -			A 402 010 03 20 A 403 010 40 20 A 403 010 89 20 A 427 010 00 20 A 427 010 10 20 A 429 010 02 20 A 442 010 07 20	<b>20 0803 40300</b>
	- V - G - S -	- - - -	ready-to-install		A 427 010 10 20	<b>20 0803 40301</b>

## 323 125

OM 495

900-001 (AFS), 900-002 (AFS), 900-003 (AFS), 900-009 (AFS), 900-010 (AFS)

08.1973 → 09.1996 D 5 9204 cm<sup>3</sup> 2V 135 kW (183 PS) 17:1 150,00 mm

OM 496

900-001 (AFS), 900-002 (AFS), 900-003 (AFS), 900-023 (AFS), 900-026 (AFS), 900-027 (AFS), 900-030 (AFS), 900-031 (AFS), 900-034 (AFS), 900-035 (AFS), 900-201 (AFS)

09.1967 → D 6 11412 cm<sup>3</sup> 2V 147-162 kW (200-220 PS) 16,5:1 155,00 mm

93 298 6..

	IN [1]	59,0 x 12 x 142,5	A/S - Cr -	- 30° - -	5 - III	A 403 053 09 01 A 422 050 00 26 A 422 050 02 26 A 422 050 05 26 A 422 053 01 01 A 423 050 00 26 A 442 050 02 26 A 442 050 03 26	<b>16117</b>
	IN [1]	59,0 x 12 x 142,5	A/S - Cr -	- 30° - -	5 - III	A 442 050 05 26	<b>16146</b>
	EX [1]	51,0 x 12 x 142,5	RA/S- Cr -	- 45° - -	5 - III	A 422 050 01 27 A 422 050 02 27 A 442 050 01 27 A 442 050 02 27 A 442 050 03 27 A 442 050 04 27	<b>16150</b>
	[50]	Ø 12 mm				A 422 053 00 26	<b>LK-1610</b>
	IN/EX [6]	18,03 x 12 x 67,0	G1			A 403 053 00 30	<b>81-1647</b>
	IN/EX [6]	18,03 x 12 x 67,0	G2			A 422 053 04 30	<b>81-16100</b>
	IN/EX [6]	18,23 x 12 x 67,0	G1			A 403 053 01 30	<b>81-1648</b>

Fortsetzung nächste Seite / continued on next page / suite page suivante / continuación página próxima / Продолжение на следующей странице

					Reference	Item No.
IN [2]	60,11 x 51 x 8,9	G1 30°			A 403 053 09 31 A 403 053 15 31	<b>92-16100</b>
IN [1]	60,31 x 51 x 9,1	G1 30°			A 403 053 10 31	<b>92-16147</b>
IN [1]	60,51 x 51 x 9,3	G1 30°			A 403 053 11 31	<b>92-16101</b>
EX [2]	53,11 x 43 x 9,7	G1 45°			A 403 053 00 32 A 403 053 03 32 A 403 053 21 32 A 403 053 25 32 A 403 053 28 32	<b>92-16104</b>
EX [1]	53,31 x 43 x 9,9	G1 45°			A 403 053 01 32 A 403 053 13 32 A 403 053 22 32 A 403 053 26 32 A 403 053 29 32	<b>92-16148</b>
EX [1]	53,51 x 43 x 10,2	G1 45°			A 403 053 02 32 A 403 053 23 32 A 403 053 27 32 A 403 053 30 32	<b>92-16105</b>
[1]					A 403 050 03 33 A 403 050 07 33 A 442 050 03 33	<b>20 1003 40010</b>
[1]					A 403 050 03 33 A 403 050 07 33 A 442 050 03 33 A 442 055 00 20	<b>20 1003 40012 (1)</b>
(1) mit Einstellschraube/with adjusting screw/avec vis de réglage/con tornillo de ajuste/с установочным ВИНТОМ						

M

## 324 125

<b>OM 401</b>	<b>900, 900-001</b>							
	04.1972 → 1985	D	6	2V	129 kW	(175 PS)	130,00 mm	
<b>OM 401 Euro 1</b>	<b>901-504</b>							
	1992 →	D (LA)	6	9572 cm <sup>3</sup> 2V			130,00 mm	
<b>OM 401</b>	<b>900-400</b>							
	01.1976 → 12.1989	D (A)	6	9572 cm <sup>3</sup> 2V			130,00 mm	
<b>OM 403</b>	<b>900-001, 900-002, 911/-000</b>							
	01.1973 →	D	10	15960 cm <sup>3</sup> 2V	184 kW	(250 PS)	130,00 mm	
<b>OM 407</b>	<b>900/-000</b>							
	05.1982 → 12.1989	D	6	11040 cm <sup>3</sup> 2V			150,00 mm	
<b>OM 407</b>	<b>901-500</b>							
	08.1980 → 08.1980	D (LA)	6	11412 cm <sup>3</sup> 2V			155,00 mm	
<b>OM 407</b>	<b>901-400, 901-600</b>							
	08.1980 → 08.1980	D (A)	6	11412 cm <sup>3</sup> 2V			155,00 mm	

92 306 6..., 93 231 6..., 93 298 6..., 94 656 6..

IN [1]	59,0 x 12 x 142,5	A/S - Cr -	- 30° -	-	5 - III	A 403 053 09 01 A 422 050 00 26 A 422 050 02 26 A 422 050 05 26 A 422 053 01 01 A 423 050 00 26 A 442 050 02 26 A 442 050 03 26	<b>16117</b>
IN [1]	59,0 x 12 x 142,5	A/S - Cr -	- 30° -	-	5 - III	A 442 050 05 26	<b>16146</b>
IN [1]	59,0 x 12 x 142,5	S - Cr -	- 30° -	VS -	5 - III	A 423 050 00 26	<b>1606</b>
EX [1]	51,0 x 12 x 142,5	A/S - Cr -	- 45° -	-	5 - III	A 422 050 00 27	<b>16116</b>
EX [1]	51,0 x 12 x 142,5	RA/S- Cr -	- 45° -	-	5 - III	A 422 050 01 27 A 422 050 02 27 A 442 050 01 27 A 442 050 02 27 A 442 050 03 27 A 442 050 04 27	<b>16150</b>
EX [1]	51,1 x 12 x 142,5	A/S - Cr -	- 45° -	-	5 - III	A 423 050 04 27	<b>1608</b>

Fortsetzung nächste Seite / continued on next page / suite page suivante / continuación página próxima / Продолжение на следующей странице

					Reference	Item No.
[50] [50]	Ø 12 mm				A 000 053 04 26 A 422 053 00 26	LK-1605 LK-1610
IN/EX [6]	18,03 x 12 x 67,0	G2			A 422 053 04 30	81-16100
IN [2]	60,11 x 51 x 8,9	G1 30°			A 403 053 09 31 A 403 053 15 31	92-16100
IN [2]	61,11 x 51 x 9,0	G1 30°			A 403 053 03 31	92-16163
IN [1]	60,31 x 51 x 9,1	G1 30°			A 403 053 10 31	92-16147
IN [1]	60,51 x 51 x 9,3	G1 30°			A 403 053 11 31	92-16101
EX [2]	53,11 x 43 x 9,7	G1 45°			A 403 053 00 32 A 403 053 03 32 A 403 053 21 32 A 403 053 25 32 A 403 053 28 32	92-16104
EX [1]	53,31 x 43 x 9,9	G1 45°			A 403 053 01 32 A 403 053 13 32 A 403 053 22 32 A 403 053 26 32 A 403 053 29 32	92-16148
EX [1]	53,51 x 43 x 10,2	G1 45°			A 403 053 02 32 A 403 053 23 32 A 403 053 27 32 A 403 053 30 32	92-16105
[12]	M 32 x 76 x 20				A 422 050 03 25 A 476 050 00 25	20 1003 44000 (1)
[12]	M 32 x 76 x 20				A 422 050 03 25 A 476 050 00 25	20 1003 44001 <sup>NEW</sup> (2)
	(1) OES specification					
	(2) IAM specification					
[4]					A 403 050 07 33 A 442 050 03 33	20 1002 25010 (3)
[1]					A 403 050 03 33 A 403 050 07 33 A 442 050 03 33	20 1003 40010
[1]					A 403 050 03 33 A 403 050 07 33 A 442 050 03 33 A 442 055 00 20	20 1003 40012 (4)
	(3) nur 2-Ventiler/only 2 valves version/seulement 2 soupapes/sólo sistemas de 2 válvulas/заменяемо 2 Клапаны					
	(4) mit Einstellschraube/with adjusting screw/avec vis de réglage/con tornillo de ajuste/c установочным винтом					
Fortsetzung nächste Seite / continued on next page / suite page suivante / continuación página próxima / Продолжение на следующей странице						

M

					Reference	Item No.
	- - G - S -	- - -			A 402 010 03 20 A 403 010 40 20 A 403 010 89 20 A 427 010 00 20 A 427 010 10 20 A 429 010 02 20 A 442 010 07 20	<b>20 0803 40300</b>
	- V - G - S -	- - -	ready-to-install		A 427 010 10 20	<b>20 0803 40301</b>

## 325

## 125

<b>OM 401</b>	<b>905 - 906, 909, 914 - 916, 918 - 919, 922 - 923, 925 - 928</b>								
	09.1973 →	D (NA)	6	9570 cm <sup>3</sup>	2V	141 kW	(192 PS)	17,2:1	130,00 mm
<b>OM 401</b>	<b>907 - 908, 913, 921</b>								
	10.1974 →	D	6	9570 cm <sup>3</sup>	2V	141 kW	(192 PS)	17,2:1	130,00 mm
<b>OM 401</b>	<b>924</b>								
	01.1979 → 12.1982	D (NA)	6	10456 cm <sup>3</sup>	2V	144 kW	(196 PS)	17,5:1	142,00 mm
<b>OM 403</b>	<b>910</b>								
	04.1972 → 1985	D (NA)	10	15950 cm <sup>3</sup>	2V	184-236 kW	(250-321 PS)		130,00 mm

92 306 6..

	IN [1]	59,0 x 12 x 142,5	A/S - Cr -	- 30° -	-	5 - III	A 403 053 09 01 A 422 050 00 26 A 422 050 02 26 A 422 050 05 26 A 422 053 01 01 A 423 050 00 26 A 442 050 02 26 A 442 050 03 26	<b>16117</b>
	IN [1]	59,0 x 12 x 142,5	A/S - Cr -	- 30° -	-	5 - III	A 442 050 05 26	<b>16146</b>
	IN [1]	59,0 x 12 x 142,5	S - Cr -	- 30° -	VS -	5 - III	A 423 050 00 26	<b>1606</b>
	EX [1]	51,0 x 12 x 142,5	A/S - Cr -	- 45° -	-	5 - III	A 422 050 00 27	<b>16116</b>
	EX [1]	51,0 x 12 x 142,5	RA/S- Cr -	- 45° -	-	5 - III	A 422 050 01 27 A 422 050 02 27 A 442 050 01 27 A 442 050 02 27 A 442 050 03 27 A 442 050 04 27	<b>16150</b>
	EX [1]	51,1 x 12 x 142,5	A/S - Cr -	- 45° -	-	5 - III	A 423 050 04 27	<b>1608</b>
	[50]						A 000 053 04 26	<b>LK-1605</b>
	[50]	∅ 12 mm					A 422 053 00 26	<b>LK-1610</b>
	IN/EX [6]	18,03 x 12 x 67,0	G2				A 422 053 04 30	<b>81-16100</b>

Fortsetzung nächste Seite / continued on next page / suite page suivante / continuación página próxima / Продолжение на следующей странице



					Reference	Item No.
	IN [2] 60,11 x 51 x 8,9	G1 30°			A 403 053 09 31 A 403 053 15 31	<b>92-16100</b>
	IN [2] 61,11 x 51 x 9,0	G1 30°			A 403 053 03 31	<b>92-16163</b>
	IN [1] 60,31 x 51 x 9,1	G1 30°			A 403 053 10 31	<b>92-16147</b>
	IN [1] 60,51 x 51 x 9,3	G1 30°			A 403 053 11 31	<b>92-16101</b>
	EX [2] 53,11 x 43 x 9,7	G1 45°			A 403 053 00 32 A 403 053 03 32 A 403 053 21 32 A 403 053 25 32 A 403 053 28 32	<b>92-16104</b>
	EX [1] 53,31 x 43 x 9,9	G1 45°			A 403 053 01 32 A 403 053 13 32 A 403 053 22 32 A 403 053 26 32 A 403 053 29 32	<b>92-16148</b>
	EX [1] 53,51 x 43 x 10,2	G1 45°			A 403 053 02 32 A 403 053 23 32 A 403 053 27 32 A 403 053 30 32	<b>92-16105</b>
	[12] M 32 x 76 x 20				A 422 050 03 25 A 476 050 00 25	<b>20 1003 44000</b> (1)
	[12] M 31,5 x 76,5 x 20				A 403 054 09 01 A 403 054 18 01	<b>20 1003 40060</b>
	[12] M 32 x 76 x 20				A 422 050 03 25 A 476 050 00 25	<b>20 1003 44001</b> <small>NEW</small> (2)
	(1) OES specification (2) IAM specification					
	[4]				A 403 050 07 33 A 442 050 03 33	<b>20 1002 25010</b> (3)
	[1]				A 403 050 03 33 A 403 050 07 33 A 442 050 03 33	<b>20 1003 40010</b>
	[1]				A 403 050 03 33 A 403 050 07 33 A 442 050 03 33 A 442 055 00 20	<b>20 1003 40012</b> (4)
	(3) nur 2-Ventiler/only 2 valves version/seulement 2 soupapes/sólo sistemas de 2 válvulas/заменяемо 2 Клапаны					
	(4) mit Einstellschraube/with adjusting screw/avec vis de réglage/con tornillo de ajuste/c установочным винтом					
	- - G - S -	- - - -			A 402 010 03 20 A 403 010 40 20 A 403 010 89 20 A 427 010 00 20 A 427 010 10 20 A 429 010 02 20 A 442 010 07 20	<b>20 0803 40300</b>
	- V - G - S -	- - - -	ready-to-install		A 427 010 10 20	<b>20 0803 40301</b>

M

					Reference	Item No.		
<b>326</b>		<b>125</b>						
<b>OM 402</b>	<b>900-400, 900/-000</b>		D (A)	8	12760 cm <sup>3</sup> 2V	180 kW (245 PS)	130,00 mm	
<b>OM 402</b>	<b>900-001, 900-003, 900-004</b>		D	8	12760 cm <sup>3</sup> 2V	147-188 kW (188-256 PS)	16,75:1 130,00 mm	
92 306 6..								
	IN [1]	59,0 x 12 x 142,5	A/S - Cr -	- 30° -	-	5 - III	A 403 053 09 01 A 422 050 00 26 A 422 050 02 26 A 422 050 05 26 A 422 053 01 01 A 423 050 00 26 A 442 050 02 26 A 442 050 03 26	<b>16117</b>
	IN [1]	59,0 x 12 x 142,5	A/S - Cr -	- 30° -	-	5 - III	A 442 050 05 26	<b>16146</b>
	IN [1]	59,0 x 12 x 142,5	S - Cr -	- 30° -	VS -	5 - III	A 423 050 00 26	<b>1606</b>
	EX [1]	51,0 x 12 x 142,5	A/S - Cr -	- 45° -	-	5 - III	A 422 050 00 27	<b>16116</b>
	EX [1]	51,0 x 12 x 142,5	RA/S- Cr -	- 45° -	-	5 - III	A 422 050 01 27 A 422 050 02 27 A 442 050 01 27 A 442 050 02 27 A 442 050 03 27 A 442 050 04 27	<b>16150</b>
	EX [1]	51,1 x 12 x 142,5	A/S - Cr -	- 45° -	-	5 - III	A 423 050 04 27	<b>1608</b>
	[50]						A 000 053 04 26	<b>LK-1605</b>
	[50]	Ø 12 mm					A 422 053 00 26	<b>LK-1610</b>
	IN/EX [6]	18,03 x 12 x 67,0	G2				A 422 053 04 30	<b>81-16100</b>
	IN [2]	60,11 x 51 x 8,9	G1 30°				A 403 053 09 31 A 403 053 15 31	<b>92-16100</b>
	IN [2]	61,11 x 51 x 9,0	G1 30°				A 403 053 03 31	<b>92-16163</b>
	IN [1]	60,31 x 51 x 9,1	G1 30°				A 403 053 10 31	<b>92-16147</b>
	IN [1]	60,51 x 51 x 9,3	G1 30°				A 403 053 11 31	<b>92-16101</b>
	EX [2]	53,11 x 43 x 9,7	G1 45°				A 403 053 00 32 A 403 053 03 32 A 403 053 21 32 A 403 053 25 32 A 403 053 28 32	<b>92-16104</b>
	EX [1]	53,31 x 43 x 9,9	G1 45°				A 403 053 01 32 A 403 053 13 32 A 403 053 22 32 A 403 053 26 32 A 403 053 29 32	<b>92-16148</b>
	EX [1]	53,51 x 43 x 10,2	G1 45°				A 403 053 02 32 A 403 053 23 32 A 403 053 27 32 A 403 053 30 32	<b>92-16105</b>
		724 mm					A 402 050 11 01 A 402 050 13 01 A 402 050 16 01 A 402 050 18 01	<b>20 1003 40200</b>
	[12]	M 32 x 76 x 20					A 422 050 03 25 A 476 050 00 25	<b>20 1003 44000</b> (1)
	[12]	M 32 x 76 x 20					A 422 050 03 25 A 476 050 00 25	<b>20 1003 44001</b> <b>NEW</b> (2)
	(1)	OES specification						
	(2)	IAM specification						
Fortsetzung nächste Seite / continued on next page / suite page suivante / continuación página próxima / Продолжение на следующей странице								

M

					Reference	Item No.
 [4] [1] [1]					A 403 050 07 33 A 442 050 03 33 A 403 050 03 33 A 403 050 07 33 A 442 050 03 33 A 403 050 03 33 A 403 050 07 33 A 442 050 03 33 A 442 055 00 20	20 1002 25010 (3)  20 1003 40010  20 1003 40012 (4)
(3)	nur 2-Ventiler/only 2 valves version/seulement 2 soupapes/sólo sistemas de 2 válvulas/заменяемо 2 Клапаны					
(4)	mit Einstellschraube/with adjusting screw/avec vis de réglage/con tornillo de ajuste/c установочным винтом					
	- - G - S -	- - -			A 402 010 03 20 A 403 010 40 20 A 403 010 89 20 A 427 010 00 20 A 427 010 10 20 A 429 010 02 20 A 442 010 07 20	20 0803 40300
	- V - G - S -	- - -	ready-to-install		A 427 010 10 20	20 0803 40301

**327**
**125**
**OM 402**
**905, 907, 910 - 914, 916 - 917, 919, 921, 923 - 928**

04.1972→

D (NA) 8

2V

176-188 kW

(240-256 PS)

17,2:1

130,00 mm

92 306 6..

 IN [1]	59,0 x 12 x 142,5	A/S - Cr -	- 30° - -	5 - III	A 403 053 09 01 A 422 050 00 26 A 422 050 02 26 A 422 050 05 26 A 422 053 01 01 A 423 050 00 26 A 442 050 02 26 A 442 050 03 26	16117
IN [1]	59,0 x 12 x 142,5	A/S - Cr -	- 30° - -	5 - III	A 442 050 05 26	16146
IN [1]	59,0 x 12 x 142,5	S - Cr -	- 30° - VS -	5 - III	A 423 050 00 26	1606
EX [1]	51,0 x 12 x 142,5	A/S - Cr -	- 45° - -	5 - III	A 422 050 00 27	16116
EX [1]	51,0 x 12 x 142,5	RA/S- Cr -	- 45° - -	5 - III	A 422 050 01 27 A 422 050 02 27 A 442 050 01 27 A 442 050 02 27 A 442 050 03 27 A 442 050 04 27	16150
EX [1]	51,1 x 12 x 142,5	A/S - Cr -	- 45° - -	5 - III	A 423 050 04 27	1608
 [50] [50]	Ø 12 mm				A 000 053 04 26 A 422 053 00 26	LK-1605 LK-1610

Fortsetzung nächste Seite / continued on next page / suite page suivante / continuación página próxima / Продолжение на следующей странице

					Reference	Item No.	
	IN/EX [6]	18,03 x 12 x 67,0	G1		A 403 053 00 30	<b>81-1647</b>	
	IN/EX [6]	18,03 x 12 x 67,0	G2		A 422 053 04 30	<b>81-16100</b>	
	IN/EX [6]	18,23 x 12 x 67,0	G1		A 403 053 01 30	<b>81-1648</b>	
	IN [2]	60,11 x 51 x 8,9	G1 30°		A 403 053 09 31 A 403 053 15 31	<b>92-16100</b>	
	IN [2]	61,11 x 51 x 9,0	G1 30°		A 403 053 03 31	<b>92-16163</b>	
	IN [1]	60,31 x 51 x 9,1	G1 30°		A 403 053 10 31	<b>92-16147</b>	
	IN [1]	60,51 x 51 x 9,3	G1 30°		A 403 053 11 31	<b>92-16101</b>	
	EX [2]	53,11 x 43 x 9,7	G1 45°		A 403 053 00 32 A 403 053 03 32 A 403 053 21 32 A 403 053 25 32 A 403 053 28 32	<b>92-16104</b>	
	EX [1]	53,31 x 43 x 9,9	G1 45°		A 403 053 01 32 A 403 053 13 32 A 403 053 22 32 A 403 053 26 32 A 403 053 29 32	<b>92-16148</b>	
	EX [1]	53,51 x 43 x 10,2	G1 45°		A 403 053 02 32 A 403 053 23 32 A 403 053 27 32 A 403 053 30 32	<b>92-16105</b>	
		724 mm			A 402 050 11 01 A 402 050 13 01 A 402 050 16 01 A 402 050 18 01	<b>20 1003 40200</b>	
	[12]	M 31,5 x 76,5 x 20			A 403 054 09 01 A 403 054 18 01	<b>20 1003 40060</b>	
	[12]	M 32 x 76 x 20			A 422 050 03 25 A 476 050 00 25	<b>20 1003 44000</b> (1)	
	[12]	M 32 x 76 x 20			A 422 050 03 25 A 476 050 00 25	<b>20 1003 44001</b> <b>NEW</b> (2)	
	(1)	OES specification					
(2)	IAM specification						
	[4]				A 403 050 07 33 A 442 050 03 33	<b>20 1002 25010</b> (3)	
	[1]				A 403 050 03 33 A 403 050 07 33 A 442 050 03 33	<b>20 1003 40010</b>	
	[1]				A 403 050 03 33 A 403 050 07 33 A 442 050 03 33 A 442 055 00 20	<b>20 1003 40012</b> (4)	
	(3)	nur 2-Ventiler/only 2 valves version/seulement 2 soupapes/sólo sistemas de 2 válvulas/заменяемо 2 Клапаны					
	(4)	mit Einstellschraube/with adjusting screw/avec vis de réglage/con tornillo de ajuste/c установочным ВИНТОМ					
Fortsetzung nächste Seite / continued on next page / suite page suivante / continuación página próxima / Продолжение на следующей странице							

					Reference	Item No.
	- - G - S -	- - - -			A 402 010 03 20 A 403 010 40 20 A 403 010 89 20 A 427 010 00 20 A 427 010 10 20 A 429 010 02 20 A 442 010 07 20	<b>20 0803 40300</b>
	- V - G - S -	- - - -	ready-to-install		A 427 010 10 20	<b>20 0803 40301</b>

**328**
**125**
**OM 403**
**900/-000**

01.1973 → 12.1989 D

 10 15960 cm<sup>3</sup> 2V

17,2:1 130,00 mm

92 306 6..

**M**

	IN [1]	59,0 x 12 x 142,5	A/S - Cr -	- 30° - -	5 - III	A 403 053 09 01 A 422 050 00 26 A 422 050 02 26 A 422 050 05 26 A 422 053 01 01 A 423 050 00 26 A 442 050 02 26 A 442 050 03 26	<b>16117</b>
	IN [1]	59,0 x 12 x 142,5	A/S - Cr -	- 30° - -	5 - III	A 442 050 05 26	<b>16146</b>
	IN [1]	59,0 x 12 x 142,5	S - Cr -	- 30° - VS -	5 - III	A 423 050 00 26	<b>1606</b>
	EX [1]	51,0 x 12 x 142,5	A/S - Cr -	- 45° - -	5 - III	A 422 050 00 27	<b>16116</b>
	EX [1]	51,0 x 12 x 142,5	RA/S- Cr -	- 45° - -	5 - III	A 422 050 01 27 A 422 050 02 27 A 442 050 01 27 A 442 050 02 27 A 442 050 03 27 A 442 050 04 27	<b>16150</b>
	EX [1]	51,1 x 12 x 142,5	A/S - Cr -	- 45° - -	5 - III	A 423 050 04 27	<b>1608</b>
	[50] [50]	Ø 12 mm				A 000 053 04 26 A 422 053 00 26	<b>LK-1605</b> <b>LK-1610</b>
	IN/EX [6]	18,03 x 12 x 67,0	G2			A 422 053 04 30	<b>81-16100</b>

Fortsetzung nächste Seite / continued on next page / suite page suivante / continuación página próxima / Продолжение на следующей странице



					Reference	Item No.	
	IN [2]	60,11 x 51 x 8,9	G1 30°		A 403 053 09 31 A 403 053 15 31	<b>92-16100</b>	
	IN [2]	61,11 x 51 x 9,0	G1 30°		A 403 053 03 31	<b>92-16163</b>	
	IN [1]	60,31 x 51 x 9,1	G1 30°		A 403 053 10 31	<b>92-16147</b>	
	IN [1]	60,51 x 51 x 9,3	G1 30°		A 403 053 11 31	<b>92-16101</b>	
	EX [2]	53,11 x 43 x 9,7	G1 45°		A 403 053 00 32 A 403 053 03 32 A 403 053 21 32 A 403 053 25 32 A 403 053 28 32	<b>92-16104</b>	
	EX [1]	53,31 x 43 x 9,9	G1 45°		A 403 053 01 32 A 403 053 13 32 A 403 053 22 32 A 403 053 26 32 A 403 053 29 32	<b>92-16148</b>	
	EX [1]	53,51 x 43 x 10,2	G1 45°		A 403 053 02 32 A 403 053 23 32 A 403 053 27 32 A 403 053 30 32	<b>92-16105</b>	
		[12]	M 32 x 76 x 20			A 422 050 03 25 A 476 050 00 25	<b>20 1003 44000</b> (1)
		[12]	M 32 x 76 x 20			A 422 050 03 25 A 476 050 00 25	<b>20 1003 44001</b> <span style="border: 1px solid black; padding: 1px;">NEW</span> (2)
		(1) OES specification					
	(2) IAM specification						
	[1]				A 403 050 03 33 A 403 050 07 33 A 442 050 03 33	<b>20 1003 40010</b>	
	[1]				A 403 050 03 33 A 403 050 07 33 A 442 050 03 33 A 442 055 00 20	<b>20 1003 40012</b> (3)	
	(3) mit Einstellschraube/with adjusting screw/avec vis de réglage/con tornillo de ajuste/c установочным винтом						
	- - G - S -	- - -			A 402 010 03 20 A 403 010 40 20 A 403 010 89 20 A 427 010 00 20 A 427 010 10 20 A 429 010 02 20 A 442 010 07 20	<b>20 0803 40300</b>	
		- V - G - S -	- - -	ready-to-install	A 427 010 10 20	<b>20 0803 40301</b>	

M

					Reference	Item No.	
<b>329</b>		<b>125</b>					
<b>OM 404</b>	<b>900/-000</b>	01.1973 → 12.1989 D	12	19140 cm <sup>3</sup>	2V	130,00 mm	
<b>OM 404</b>	<b>901-400</b>	01.1973 → 12.1989 D (A)	12	20911 cm <sup>3</sup>	2V	142,00 mm	
<b>OM 404</b>	<b>901/-000</b>	01.1973 → 12.1989 D	12	20911 cm <sup>3</sup>	2V	142,00 mm	
<b>OM 409</b>	<b>901-000</b>	01.1985 → 12.1989 D	5	9204 cm <sup>3</sup>	2V	150,00 mm	
92 306 6.., 93 298 6..							
	IN [1]	59,0 x 12 x 142,5	A/S - Cr -	- 30° -	- 5 - III	A 403 053 09 01 A 422 050 00 26 A 422 050 02 26 A 422 050 05 26 A 422 053 01 01 A 423 050 00 26 A 442 050 02 26 A 442 050 03 26	<b>16117</b>
	IN [1]	59,0 x 12 x 142,5	A/S - Cr -	- 30° -	- 5 - III	A 442 050 05 26	<b>16146</b>
	IN [1]	59,0 x 12 x 142,5	S - Cr -	- 30° - VS -	- 5 - III	A 423 050 00 26	<b>1606</b>
	EX [1]	51,0 x 12 x 142,5	A/S - Cr -	- 45° -	- 5 - III	A 422 050 00 27	<b>16116</b>
	EX [1]	51,0 x 12 x 142,5	RA/S- Cr -	- 45° -	- 5 - III	A 422 050 01 27 A 422 050 02 27 A 442 050 01 27 A 442 050 02 27 A 442 050 03 27 A 442 050 04 27	<b>16150</b>
	EX [1]	51,1 x 12 x 142,5	A/S - Cr -	- 45° -	- 5 - III	A 423 050 04 27	<b>1608</b>
	[50] [50]	∅ 12 mm				A 000 053 04 26 A 422 053 00 26	<b>LK-1605</b> <b>LK-1610</b>
	IN/EX [6]	18,03 x 12 x 67,0	G2			A 422 053 04 30	<b>81-16100</b>
	IN [2]	60,11 x 51 x 8,9	G1 30°			A 403 053 09 31 A 403 053 15 31	<b>92-16100</b>
	IN [2]	61,11 x 51 x 9,0	G1 30°			A 403 053 03 31	<b>92-16163</b>
	IN [1]	60,31 x 51 x 9,1	G1 30°			A 403 053 10 31	<b>92-16147</b>
	IN [1]	60,51 x 51 x 9,3	G1 30°			A 403 053 11 31	<b>92-16101</b>
	EX [2]	53,11 x 43 x 9,7	G1 45°			A 403 053 00 32 A 403 053 03 32 A 403 053 21 32 A 403 053 25 32 A 403 053 28 32	<b>92-16104</b>
	EX [1]	53,31 x 43 x 9,9	G1 45°			A 403 053 01 32 A 403 053 13 32 A 403 053 22 32 A 403 053 26 32 A 403 053 29 32	<b>92-16148</b>
	EX [1]	53,51 x 43 x 10,2	G1 45°			A 403 053 02 32 A 403 053 23 32 A 403 053 27 32 A 403 053 30 32	<b>92-16105</b>
	[4]					A 403 050 07 33 A 442 050 03 33	<b>20 1002 25010</b> (1)
	[1]					A 403 050 03 33 A 403 050 07 33 A 442 050 03 33	<b>20 1003 40010</b>
	[1]					A 403 050 03 33 A 403 050 07 33 A 442 050 03 33 A 442 055 00 20	<b>20 1003 40012</b> (2)

Fortsetzung nächste Seite / continued on next page / suite page suivante / continuación página próxima / Продолжение на следующей странице

					Reference	Item No.
(1)	nur 2-Ventiler/only 2 valves version/seulement 2 soupapes/sólo sistemas de 2 válvulas/заменяемо 2 Клапаны					
(2)	mit Einstellschraube/with adjusting screw/avec vis de réglage/con tornillo de ajuste/c установочным ВИНТОМ					
	- - G - S -	- - -			A 402 010 03 20 A 403 010 40 20 A 403 010 89 20 A 427 010 00 20 A 427 010 10 20 A 429 010 02 20 A 442 010 07 20	<b>20 0803 40300</b>
	- V - G - S -	- - -	ready-to-install		A 427 010 10 20	<b>20 0803 40301</b>

M

## 330 125

<b>OM 401</b>	<b>912</b>	10.1974 → 06.1983	D (K)	6	9570 cm <sup>3</sup>	2V	141 kW	(192 PS)	17,2:1	130,00 mm
<b>OM 401</b>	<b>917</b>		D (A)	6	9570 cm <sup>3</sup>	2V	188 kW	(256 PS)	17,2:1	130,00 mm
<b>OM 403</b>	<b>905 - 906, 915 - 919, 930 - 935</b>	08.1973 →	D (NA)	10	15950 cm <sup>3</sup>	2V	184-261 kW	(250-355 PS)	17,2:1	130,00 mm
<b>OM 407</b>	<b>908</b>	04.1973 → 07.1977	D (LA)	6	11040 cm <sup>3</sup>	2V	132 kW	(180 PS)	17:1	150,00 mm
<b>OM 407</b>	<b>905, 907, 909 - 911</b>	04.1973 → 07.1977	D (NA)	6	11040 cm <sup>3</sup>	2V	132-155 kW	(180-211 PS)	17:1	150,00 mm
<b>OM 407</b>	<b>913 - 920</b>	11.1976 →	D (NA)	6	11413 cm <sup>3</sup>	2V	147-177 kW	(200-240 PS)	16,5:1	155,00 mm
<b>OM 407</b>	<b>901/-000</b>	08.1980 → 08.1980	D	6	11412 cm <sup>3</sup>	2V				155,00 mm







92 306 6..., 93 298 6..

	IN [1]	59,0 x 12 x 142,5	A/S - Cr -	- 30° -	-	5 - III	A 403 053 09 01 A 422 050 00 26 A 422 050 02 26 A 422 050 05 26 A 422 053 01 01 A 423 050 00 26 A 442 050 02 26 A 442 050 03 26	<b>16117</b>
	IN [1]	59,0 x 12 x 142,5	A/S - Cr -	- 30° -	-	5 - III	A 442 050 05 26	<b>16146</b>
	IN [1]	59,0 x 12 x 142,5	S - Cr -	- 30° -	VS -	5 - III	A 423 050 00 26	<b>1606</b>
	EX [1]	51,0 x 12 x 142,5	A/S - Cr -	- 45° -	-	5 - III	A 422 050 00 27	<b>16116</b>
	EX [1]	51,0 x 12 x 142,5	RA/S- Cr -	- 45° -	-	5 - III	A 422 050 01 27 A 422 050 02 27 A 442 050 01 27 A 442 050 02 27 A 442 050 03 27 A 442 050 04 27	<b>16150</b>
	EX [1]	51,1 x 12 x 142,5	A/S - Cr -	- 45° -	-	5 - III	A 423 050 04 27	<b>1608</b>
	[50]						A 000 053 04 26	<b>LK-1605</b>
	[50]	Ø 12 mm					A 422 053 00 26	<b>LK-1610</b>

Fortsetzung nächste Seite / continued on next page / suite page suivante / continuación página próxima / Продолжение на следующей странице

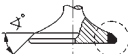
					Reference	Item No.	
	IN/EX [6]	18,03 x 12 x 67,0	G1		A 403 053 00 30	<b>81-1647</b>	
	IN/EX [6]	18,03 x 12 x 67,0	G2		A 422 053 04 30	<b>81-16100</b>	
	IN/EX [6]	18,23 x 12 x 67,0	G1		A 403 053 01 30	<b>81-1648</b>	
	IN [2]	60,11 x 51 x 8,9	G1 30°		A 403 053 09 31 A 403 053 15 31	<b>92-16100</b>	
	IN [2]	61,11 x 51 x 9,0	G1 30°		A 403 053 03 31	<b>92-16163</b>	
	IN [1]	60,31 x 51 x 9,1	G1 30°		A 403 053 10 31	<b>92-16147</b>	
	IN [1]	60,51 x 51 x 9,3	G1 30°		A 403 053 11 31	<b>92-16101</b>	
	EX [2]	53,11 x 43 x 9,7	G1 45°		A 403 053 00 32 A 403 053 03 32 A 403 053 21 32 A 403 053 25 32 A 403 053 28 32	<b>92-16104</b>	
	EX [1]	53,31 x 43 x 9,9	G1 45°		A 403 053 01 32 A 403 053 13 32 A 403 053 22 32 A 403 053 26 32 A 403 053 29 32	<b>92-16148</b>	
	EX [1]	53,51 x 43 x 10,2	G1 45°		A 403 053 02 32 A 403 053 23 32 A 403 053 27 32 A 403 053 30 32	<b>92-16105</b>	
		[12]	M 31,5 x 76,5 x 20			A 403 054 09 01 A 403 054 18 01	<b>20 1003 40060</b>
		[12]	M 32 x 76 x 20			A 422 050 03 25 A 476 050 00 25	<b>20 1003 44000</b> (1)
		[12]	M 32 x 76 x 20			A 422 050 03 25 A 476 050 00 25	<b>20 1003 44001</b> <small>NEW</small> (2)
(1)		OES specification					
(2)	IAM specification						
	[4]				A 403 050 07 33 A 442 050 03 33	<b>20 1002 25010</b> (3)	
	[1]				A 403 050 03 33 A 403 050 07 33 A 442 050 03 33	<b>20 1003 40010</b>	
	[1]				A 403 050 03 33 A 403 050 07 33 A 442 050 03 33 A 442 055 00 20	<b>20 1003 40012</b> (4)	
	(3)	nur 2-Ventiler/only 2 valves version/seulement 2 soupapes/sólo sistemas de 2 válvulas/заменяемо 2 Клапаны					
(4)	mit Einstellschraube/with adjusting screw/avec vis de réglage/con tornillo de ajuste/c установочным винтом						
Fortsetzung nächste Seite / continued on next page / suite page suivante / continuación página próxima / Продолжение на следующей странице							

**M**

					Reference	Item No.
	- - G - S -	- - -			A 402 010 03 20 A 403 010 40 20 A 403 010 89 20 A 427 010 00 20 A 427 010 10 20 A 429 010 02 20 A 442 010 07 20	<b>20 0803 40300</b>
						
	- V - G - S -	- - -	ready-to-install		A 427 010 10 20	<b>20 0803 40301</b>
						

**331**  **125**



OM 402

906

08.1973 → 12.1980 D (NA) 8 12760 cm<sup>3</sup> 2V 188 kW (256 PS) 130,00 mm

92 306 6..

M

	IN [1]	59,0 x 12 x 142,5	A/S - Cr -	- 30° - -	5 - III	A 403 053 09 01 A 422 050 00 26 A 422 050 02 26 A 422 050 05 26 A 422 053 01 01 A 423 050 00 26 A 442 050 02 26 A 442 050 03 26	<b>16117</b>
	IN [1]	59,0 x 12 x 142,5	A/S - Cr -	- 30° - -	5 - III	A 442 050 05 26	<b>16146</b>
	IN [1]	59,0 x 12 x 142,5	S - Cr -	- 30° - VS -	5 - III	A 423 050 00 26	<b>1606</b>
	EX [1]	51,0 x 12 x 142,5	A/S - Cr -	- 45° - -	5 - III	A 422 050 00 27	<b>16116</b>
	EX [1]	51,0 x 12 x 142,5	RA/S- Cr -	- 45° - -	5 - III	A 422 050 01 27 A 422 050 02 27 A 442 050 02 27 A 442 050 03 27 A 442 050 04 27	<b>16150</b>
	EX [1]	51,1 x 12 x 142,5	A/S - Cr -	- 45° - -	5 - III	A 423 050 04 27	<b>1608</b>
	[50]	Ø 12 mm				A 422 053 00 26	<b>LK-1610</b>
	IN/EX [6]	18,03 x 12 x 67,0	G1			A 403 053 00 30	<b>81-1647</b>
	IN/EX [6]	18,03 x 12 x 67,0	G2			A 422 053 04 30	<b>81-16100</b>
	IN/EX [6]	18,23 x 12 x 67,0	G1			A 403 053 01 30	<b>81-1648</b>

Fortsetzung nächste Seite / continued on next page / suite page suivante / continuación página próxima / Продолжение на следующей странице



					Reference	Item No.
	IN [2] 60,11 x 51 x 8,9	G1 30°			A 403 053 09 31 A 403 053 15 31	<b>92-16100</b>
	IN [2] 61,11 x 51 x 9,0	G1 30°			A 403 053 03 31	<b>92-16163</b>
	IN [1] 60,31 x 51 x 9,1	G1 30°			A 403 053 10 31	<b>92-16147</b>
	IN [1] 60,51 x 51 x 9,3	G1 30°			A 403 053 11 31	<b>92-16101</b>
	EX [2] 53,11 x 43 x 9,7	G1 45°			A 403 053 00 32 A 403 053 03 32 A 403 053 21 32 A 403 053 25 32 A 403 053 28 32	<b>92-16104</b>
	EX [1] 53,31 x 43 x 9,9	G1 45°			A 403 053 01 32 A 403 053 13 32 A 403 053 22 32 A 403 053 26 32 A 403 053 29 32	<b>92-16148</b>
	EX [1] 53,51 x 43 x 10,2	G1 45°			A 403 053 02 32 A 403 053 23 32 A 403 053 27 32 A 403 053 30 32	<b>92-16105</b>
	724 mm				A 402 050 11 01 A 402 050 13 01 A 402 050 16 01 A 402 050 18 01	<b>20 1003 40200</b>
	[12] M 32 x 76 x 20				A 422 050 03 25 A 476 050 00 25	<b>20 1003 44000</b> (1)
	[12] M 32 x 76 x 20				A 422 050 03 25 A 476 050 00 25	<b>20 1003 44001</b> <small>NEW</small> (2)
	(1) OES specification					
	(2) IAM specification					
	[1]				A 403 050 03 33 A 403 050 07 33 A 442 050 03 33	<b>20 1003 40010</b>
	[1]				A 403 050 03 33 A 403 050 07 33 A 442 050 03 33 A 442 055 00 20	<b>20 1003 40012</b> (3)
	(3) mit Einstellschraube/with adjusting screw/avec vis de réglage/con tornillo de ajuste/c установочным винтом					
	- - G - S -	- - -			A 402 010 03 20 A 403 010 40 20 A 403 010 89 20 A 427 010 00 20 A 427 010 10 20 A 429 010 02 20 A 442 010 07 20	<b>20 0803 40300</b>
	- V - G - S -	- - -	ready-to-install		A 427 010 10 20	<b>20 0803 40301</b>

**M**

					Reference	Item No.	
<b>332</b>	125						
OM 496	900-401 (AFS), 900-402 (AFS), 900-425 (AFS), 900-426 (AFS), 900-429 (AFS), 900-430 (AFS), 900-431 (AFS), 900-501 (AFS)						
93 585 6..	08.1973 →	D	6	11412 cm <sup>3</sup> 2V	202-235 kW (275-320 PS) 16,5:1	155,00 mm	
	IN [1]	59,0 x 12 x 142,5	A/S - Cr -	- 30° - -	5 - III	A 403 053 09 01 A 422 050 00 26 A 422 050 02 26 A 422 050 05 26 A 422 053 01 01 A 423 050 00 26 A 442 050 02 26 A 442 050 03 26	<b>16117</b>
	IN [1]	59,0 x 12 x 142,5	A/S - Cr -	- 30° - -	5 - III	A 442 050 05 26	<b>16146</b>
	EX [1]	51,0 x 12 x 142,5	RA/S- Cr -	- 45° - -	5 - III	A 422 050 01 27 A 422 050 02 27 A 442 050 01 27 A 442 050 02 27 A 442 050 03 27 A 442 050 04 27	<b>16150</b>
	[50]	Ø 12 mm				A 422 053 00 26	<b>LK-1610</b>
	IN/EX [6]	18,03 x 12 x 67,0	G1			A 403 053 00 30	<b>81-1647</b>
	IN/EX [6]	18,03 x 12 x 67,0	G2			A 422 053 04 30	<b>81-16100</b>
	IN/EX [6]	18,23 x 12 x 67,0	G1			A 403 053 01 30	<b>81-1648</b>
	IN [2]	60,11 x 51 x 8,9	G1 30°			A 403 053 09 31 A 403 053 15 31	<b>92-16100</b>
	IN [2]	60,11 x 51.2 x 8,4	G1 30°			A 422 053 05 31	<b>92-16151</b>
	IN [1]	60,31 x 51 x 9,1	G1 30°			A 403 053 10 31	<b>92-16147</b>
	IN [1]	60,31 x 51.2 x 8,6	G1 30°			A 422 053 06 31	<b>92-16152</b>
	IN [1]	60,51 x 51 x 9,3	G1 30°			A 403 053 11 31	<b>92-16101</b>
	EX [2]	53,11 x 43 x 9,2	G1 45°			A 442 053 00 32	<b>92-16127</b>
	EX [2]	53,11 x 43 x 9,7	G1 45°			A 403 053 00 32 A 403 053 03 32 A 403 053 21 32 A 403 053 25 32 A 403 053 28 32	<b>92-16104</b>
	EX [1]	53,11 x 43 x 9,2	G1 45°			A 422 053 01 32	<b>92-16126</b>
	EX [1]	53,31 x 43 x 9,4	G1 45°			A 442 053 01 32	<b>92-16149</b>
	EX [1]	53,31 x 43 x 9,9	G1 45°			A 403 053 01 32 A 403 053 13 32 A 403 053 22 32 A 403 053 26 32 A 403 053 29 32	<b>92-16148</b>
	EX [1]	53,51 x 43 x 10,2	G1 45°			A 403 053 02 32 A 403 053 23 32 A 403 053 27 32 A 403 053 30 32	<b>92-16105</b>
	EX [1]	53,51 x 43.2 x 9,6	G1 45°			A 442 053 02 32	<b>92-16128</b>
	[1]					A 403 050 03 33 A 403 050 07 33	<b>20 1003 40010</b>
	[1]					A 442 050 03 33 A 403 050 03 33 A 403 050 07 33 A 442 050 03 33 A 442 055 00 20	<b>20 1003 40012 (1)</b>
	(1)	mit Einstellschraube/with adjusting screw/avec vis de réglage/con tornillo de ajuste/c установочным ВИНТОМ					

					Reference	Item No.		
<b>333</b>		<b>125</b>	<b>OM 404</b> <b>918</b> 1977 → 1982      D      12      20911 cm <sup>3</sup> 2V      236 kW      (320 PS)      17,2:1      142,00 mm					
	IN [1]	59,0 x 12 x 142,5	A/S - Cr -	- 30° -	-	5 - III	A 403 053 09 01 A 422 050 00 26 A 422 050 02 26 A 422 050 05 26 A 422 053 01 01 A 423 050 00 26 A 442 050 02 26 A 442 050 03 26	<b>16117</b>
	IN [1]	59,0 x 12 x 142,5	A/S - Cr -	- 30° -	-	5 - III	A 442 050 05 26	<b>16146</b>
	IN [1]	59,0 x 12 x 142,5	S - Cr -	- 30° -	VS -	5 - III	A 423 050 00 26	<b>1606</b>
	EX [1]	51,0 x 12 x 142,5	A/S - Cr -	- 45° -	-	5 - III	A 422 050 00 27	<b>16116</b>
	EX [1]	51,0 x 12 x 142,5	RA/S- Cr -	- 45° -	-	5 - III	A 422 050 01 27 A 422 050 02 27 A 442 050 01 27 A 442 050 02 27 A 442 050 03 27 A 442 050 04 27	<b>16150</b>
	EX [1]	51,1 x 12 x 142,5	A/S - Cr -	- 45° -	-	5 - III	A 423 050 04 27	<b>1608</b>
	[50] [50]	Ø 12 mm					A 000 053 04 26 A 422 053 00 26	<b>LK-1605</b> <b>LK-1610</b>
	IN/EX [6]	18,03 x 12 x 67,0	G2				A 422 053 04 30	<b>81-16100</b>
	IN [2]	60,11 x 51 x 8,9	G1 30°				A 403 053 09 31 A 403 053 15 31	<b>92-16100</b>
	IN [2]	61,11 x 51 x 9,0	G1 30°				A 403 053 03 31	<b>92-16163</b>
	IN [1]	60,31 x 51 x 9,1	G1 30°				A 403 053 10 31	<b>92-16147</b>
	IN [1]	60,51 x 51 x 9,3	G1 30°				A 403 053 11 31	<b>92-16101</b>
	EX [2]	53,11 x 43 x 9,7	G1 45°				A 403 053 00 32 A 403 053 03 32 A 403 053 21 32 A 403 053 25 32 A 403 053 28 32	<b>92-16104</b>
	EX [1]	53,31 x 43 x 9,9	G1 45°				A 403 053 01 32 A 403 053 13 32 A 403 053 22 32 A 403 053 26 32 A 403 053 29 32	<b>92-16148</b>
	EX [1]	53,51 x 43 x 10,2	G1 45°				A 403 053 02 32 A 403 053 23 32 A 403 053 27 32 A 403 053 30 32	<b>92-16105</b>

<b>334</b>		<b>125</b>	<b>OM 407</b> <b>951, 955</b> 02.1979 → 05.1987      D (A)      6      11413 cm <sup>3</sup> 2V      206 kW      (280 PS)      16,5:1      155,00 mm 93 585 6..			
------------	--	------------	---	--	--	--

Fortsetzung nächste Seite / continued on next page / suite page suivante / continuación página próxima / Продолжение на следующей странице

M

					Reference	Item No.
	IN [1] 59,0 x 12 x 142,5	A/S - Cr -	- 30° - -	5 - III	A 403 053 09 01 A 422 050 00 26 A 422 050 02 26 A 422 050 05 26 A 422 053 01 01 A 423 050 00 26 A 442 050 02 26 A 442 050 03 26	<b>16117</b>
	IN [1] 59,0 x 12 x 142,5	A/S - Cr -	- 30° - -	5 - III	A 442 050 05 26	<b>16146</b>
	IN [1] 59,0 x 12 x 142,5	S - Cr -	- 30° - VS -	5 - III	A 423 050 00 26	<b>1606</b>
	EX [1] 51,0 x 12 x 142,5	A/S - Cr -	- 45° - -	5 - III	A 422 050 00 27	<b>16116</b>
	EX [1] 51,0 x 12 x 142,5	RA/S- Cr -	- 45° - -	5 - III	A 422 050 01 27 A 422 050 02 27 A 442 050 01 27 A 442 050 02 27 A 442 050 03 27 A 442 050 04 27	<b>16150</b>
	EX [1] 51,1 x 12 x 142,5	A/S - Cr -	- 45° - -	5 - III	A 423 050 04 27	<b>1608</b>
	[50]				A 000 053 04 26	<b>LK-1605</b>
	[50] Ø 12 mm				A 422 053 00 26	<b>LK-1610</b>
	IN/EX [6] 18,03 x 12 x 67,0	G2			A 422 053 04 30	<b>81-16100</b>
	IN [2] 60,11 x 51 x 8,9	G1 30°			A 403 053 09 31 A 403 053 15 31	<b>92-16100</b>
	IN [2] 60,11 x 51.2 x 8,4	G1 30°			A 422 053 05 31	<b>92-16151</b>
	IN [2] 61,11 x 51 x 9,0	G1 30°			A 403 053 03 31	<b>92-16163</b>
	IN [1] 60,31 x 51 x 9,1	G1 30°			A 403 053 10 31	<b>92-16147</b>
	IN [1] 60,31 x 51.2 x 8,6	G1 30°			A 422 053 06 31	<b>92-16152</b>
	IN [1] 60,51 x 51 x 9,3	G1 30°			A 403 053 11 31	<b>92-16101</b>
	EX [2] 53,11 x 43 x 9,2	G1 45°			A 442 053 00 32	<b>92-16127</b>
	EX [2] 53,11 x 43 x 9,7	G1 45°			A 403 053 00 32 A 403 053 03 32 A 403 053 21 32 A 403 053 25 32 A 403 053 28 32	<b>92-16104</b>
	EX [1] 53,11 x 43 x 9,2	G1 45°			A 422 053 01 32	<b>92-16126</b>
	EX [1] 53,31 x 43 x 9,4	G1 45°			A 442 053 01 32	<b>92-16149</b>
	EX [1] 53,31 x 43 x 9,9	G1 45°			A 403 053 01 32 A 403 053 13 32 A 403 053 22 32 A 403 053 26 32 A 403 053 29 32	<b>92-16148</b>
	EX [1] 53,51 x 43 x 10,2	G1 45°			A 403 053 02 32 A 403 053 23 32 A 403 053 27 32 A 403 053 30 32	<b>92-16105</b>
	EX [1] 53,51 x 43.2 x 9,6	G1 45°			A 442 053 02 32	<b>92-16128</b>
	[12] M 31,5 x 76,5 x 20				A 403 054 09 01 A 403 054 18 01	<b>20 1003 40060</b>
	[12] M 32 x 76 x 20				A 422 050 03 25 A 476 050 00 25	<b>20 1003 44000 (1)</b>
	[12] M 32 x 76 x 20				A 422 050 03 25 A 476 050 00 25	<b>20 1003 44001 <small>NEW</small> (2)</b>
	(1) OES specification					
	(2) IAM specification					

Fortsetzung nächste Seite / continued on next page / suite page suivante / continuación página próxima / Продолжение на следующей странице

					Reference	Item No.
[4]					A 403 050 07 33	20 1002 25010 (3)
[1]					A 442 050 03 33	20 1003 40010
[1]					A 403 050 03 33	
					A 403 050 07 33	20 1003 40012 (4)
					A 442 050 03 33	
					A 403 050 07 33	
					A 442 050 03 33	
					A 442 055 00 20	
(3)					nur 2-Ventiler/only 2 valves version/seulement 2 soupapes/sólo sistemas de 2 válvulas/заменяемо 2 Клапаны	
(4)					mit Einstellschraube/with adjusting screw/avec vis de réglage/con tornillo de ajuste/c установочным винтом	
	- - G - S -	- - - -			A 402 010 03 20	20 0803 40300
					A 403 010 40 20	
					A 403 010 89 20	
					A 427 010 00 20	
					A 427 010 10 20	
					A 429 010 02 20	
					A 442 010 07 20	
	- V - G - S -	- - - -	ready-to-install		A 427 010 10 20	20 0803 40301

**335**
**125**
**OM 407**
**900-001, 900-002**

 05.1982 → 12.1989 D 6 11040 cm<sup>3</sup> 2V 132-155 kW (180-210 PS) 17:1 150,00 mm

	IN [1]	59,0 x 12 x 142,5	A/S - Cr -	- 30° - -	5 - III	A 403 053 09 01	16117	
						A 422 050 00 26		
						A 422 050 02 26		
						A 422 050 05 26		
						A 422 053 01 01		
						A 423 050 00 26		
						A 442 050 02 26		
						A 442 050 03 26		
	IN [1]	59,0 x 12 x 142,5	A/S - Cr -	- 30° - -	5 - III	A 442 050 05 26		16146
	IN [1]	59,0 x 12 x 142,5	S - Cr -	- 30° - VS -	5 - III	A 423 050 00 26		1606
	EX [1]	51,0 x 12 x 142,5	A/S - Cr -	- 45° - -	5 - III	A 422 050 00 27	16116	
	EX [1]	51,0 x 12 x 142,5	RA/S- Cr -	- 45° - -	5 - III	A 422 050 01 27	16150	
						A 422 050 02 27		
						A 442 050 01 27		
						A 442 050 02 27		
						A 442 050 03 27		
						A 442 050 04 27		
	EX [1]	51,1 x 12 x 142,5	A/S - Cr -	- 45° - -	5 - III	A 423 050 04 27	1608	
	[50]	Ø 12 mm				A 422 053 00 26	LK-1610	
	IN/EX [6]	18,03 x 12 x 67,0	G2			A 422 053 04 30	81-16100	

Fortsetzung nächste Seite / continued on next page / suite page suivante / continuación página próxima / Продолжение на следующей странице



					Reference	Item No.
IN [2]	60,11 x 51 x 8,9	G1 30°			A 403 053 09 31 A 403 053 15 31	<b>92-16100</b>
IN [2]	61,11 x 51 x 9,0	G1 30°			A 403 053 03 31	<b>92-16163</b>
IN [1]	60,31 x 51 x 9,1	G1 30°			A 403 053 10 31	<b>92-16147</b>
IN [1]	60,51 x 51 x 9,3	G1 30°			A 403 053 11 31	<b>92-16101</b>
EX [2]	53,11 x 43 x 9,7	G1 45°			A 403 053 00 32 A 403 053 03 32 A 403 053 21 32 A 403 053 25 32 A 403 053 28 32	<b>92-16104</b>
EX [1]	53,31 x 43 x 9,9	G1 45°			A 403 053 01 32 A 403 053 13 32 A 403 053 22 32 A 403 053 26 32 A 403 053 29 32	<b>92-16148</b>
EX [1]	53,51 x 43 x 10,2	G1 45°			A 403 053 02 32 A 403 053 23 32 A 403 053 27 32 A 403 053 30 32	<b>92-16105</b>

## 336 125

**OM 401 Euro 1** 970, 972 - 975, 977 - 981, 984 - 987, 989 - 991, 993 - 994  
 07.1987 → D (LA) 6 9570 cm<sup>3</sup> 2V 180-230 kW (245-313 PS) 16,75:1 130,00 mm  
 93 231 6..., 94 656 6..

M

IN [1]	59,0 x 12 x 142,5	A/S - Cr -	- 30° - -	5 - III	A 403 053 09 01 A 422 050 00 26 A 422 050 02 26 A 422 050 05 26 A 422 053 01 01 A 423 050 00 26 A 442 050 02 26 A 442 050 03 26	<b>16117</b>
IN [1]	59,0 x 12 x 142,5	A/S - Cr -	- 30° - -	5 - III	A 442 050 05 26	<b>16146</b>
IN [1]	59,0 x 12 x 142,5	S - Cr -	- 30° - VS -	5 - III	A 423 050 00 26	<b>1606</b>
EX [1]	51,0 x 12 x 142,5	RA/S- Cr -	- 45° - -	5 - III	A 422 050 01 27 A 422 050 02 27 A 442 050 01 27 A 442 050 02 27 A 442 050 03 27 A 442 050 04 27	<b>16150</b>
EX [1]	51,1 x 12 x 142,5	A/S - Cr -	- 45° - -	5 - III	A 423 050 04 27	<b>1608</b>
[50]	Ø 12 mm				A 000 053 04 26	<b>LK-1605</b>
[50]					A 422 053 00 26	<b>LK-1610</b>
IN/EX [6]	18,03 x 12 x 67,0	G2			A 422 053 04 30	<b>81-16100</b>
IN [2]	61,11 x 51 x 9,0	G1 30°			A 403 053 03 31	<b>92-16163</b>
EX [2]	53,11 x 43 x 9,2	G1 45°			A 442 053 00 32	<b>92-16127</b>
EX [1]	53,11 x 43 x 9,2	G1 45°			A 422 053 01 32	<b>92-16126</b>
EX [1]	53,31 x 43 x 9,4	G1 45°			A 442 053 01 32	<b>92-16149</b>
EX [1]	53,51 x 43,2 x 9,6	G1 45°			A 442 053 02 32	<b>92-16128</b>
	566 mm				A 401 050 19 01 A 401 050 22 01 A 441 050 17 01	<b>20 1003 40101</b>
[12]	M 31,5 x 76,5 x 20				A 403 054 09 01 A 403 054 18 01	<b>20 1003 40060</b>
[12]	M 32 x 76 x 20				A 422 050 03 25 A 476 050 00 25	<b>20 1003 44000</b> (1)
[12]	M 32 x 76 x 20				A 422 050 03 25 A 476 050 00 25	<b>20 1003 44001</b> <b>NEW</b> (2)
(1) OES specification						

Fortsetzung nächste Seite / continued on next page / suite page suivante / continuación página próxima / Продолжение на следующей странице

					Reference	Item No.
(2)	IAM specification					
[4]					A 403 050 07 33 A 442 050 03 33	<b>20 1002 25010</b> (3)
[1]					A 403 050 03 33 A 403 050 07 33 A 442 050 03 33	<b>20 1003 40010</b>
[1]					A 403 050 03 33 A 403 050 07 33 A 442 050 03 33 A 442 055 00 20	<b>20 1003 40012</b> (4)
(3)	nur 2-Ventiler/only 2 valves version/seulement 2 soupapes/sólo sistemas de 2 válvulas/заменяемо Клапаны					
(4)	mit Einstellschraube/with adjusting screw/avec vis de réglage/con tornillo de ajuste/c установочным винтом					
	- - G - S -	- - -			A 402 010 03 20 A 403 010 40 20 A 403 010 89 20 A 427 010 00 20 A 427 010 10 20 A 429 010 02 20 A 442 010 07 20	<b>20 0803 40300</b>
	- V - G - S -	- - -	ready-to-install		A 427 010 10 20	<b>20 0803 40301</b>

**337**
**125**
**OM 402 Euro 1**
**988**

 07.1987 → 09.1996 D (LA) 8 12760 cm<sup>3</sup> 2V 280 kW (381 PS) 16,75:1 130,00 mm

93 231 6.., 94 656 6..

IN [1]	59,0 x 12 x 142,5	A/S - Cr -	- 30° -	-	5 - III	A 403 053 09 01 A 422 050 00 26 A 422 050 02 26 A 422 050 05 26 A 422 053 01 01 A 423 050 00 26 A 442 050 02 26 A 442 050 03 26	<b>16117</b>
IN [1]	59,0 x 12 x 142,5	A/S - Cr -	- 30° -	-	5 - III	A 442 050 05 26	<b>16146</b>
EX [1]	51,0 x 12 x 142,5	RA/S- Cr -	- 45° -	-	5 - III	A 422 050 01 27 A 422 050 02 27 A 442 050 01 27 A 442 050 02 27 A 442 050 03 27 A 442 050 04 27	<b>16150</b>
[50]	Ø 12 mm					A 422 053 00 26	<b>LK-1610</b>
IN/EX [6]	18,03 x 12 x 67,0	G2				A 422 053 04 30	<b>81-16100</b>

Fortsetzung nächste Seite / continued on next page / suite page suivante / continuación página próxima / Продолжение на следующей странице

					Reference	Item No.
	IN [2] EX [2] EX [1] EX [1] EX [1]	61,11 x 51 x 9,0 53,11 x 43 x 9,2 53,11 x 43 x 9,2 53,31 x 43 x 9,4 53,51 x 43.2 x 9,6	G1 30° G1 45° G1 45° G1 45° G1 45°		A 403 053 03 31 A 442 053 00 32 A 422 053 01 32 A 442 053 01 32 A 442 053 02 32	<b>92-16163</b> <b>92-16127</b> <b>92-16126</b> <b>92-16149</b> <b>92-16128</b>
	724 mm				A 402 050 21 01 A 402 050 25 01 A 442 050 17 01	<b>20 1003 40201</b>
	[12] [12]	M 32 x 76 x 20 M 32 x 76 x 20			A 422 050 03 25 A 476 050 00 25 A 422 050 03 25 A 476 050 00 25	<b>20 1003 44000</b> (1) <b>20 1003 44001</b> <b>NEW</b> (2)
	(1) OES specification (2) IAM specification					

## 338 125

**OM 402 Euro 1 984, 995**  
09.1991 → D (A) 8 2V 280 kW (381 PS) 16,75:1 130,00 mm

**OM 402 Euro 1 970 - 975, 977 - 978, 982 - 983, 985 - 987, 989 - 990, 996**  
D (LA) 8 2V 280-295 kW (381-401 PS) 16,75:1 130,00 mm

93 231 6.., 94 656 6..

	IN [1]	59,0 x 12 x 142,5	A/S - Cr -	- 30° - -	5 - III	A 403 053 09 01 A 422 050 00 26 A 422 050 02 26 A 422 050 05 26 A 422 053 01 01 A 423 050 00 26 A 442 050 02 26 A 442 050 03 26	<b>16117</b>
	IN [1] EX [1]	59,0 x 12 x 142,5 51,0 x 12 x 142,5	A/S - Cr - RA/S- Cr -	- 30° - - - 45° - -	5 - III 5 - III	A 442 050 05 26 A 422 050 01 27 A 422 050 02 27 A 442 050 01 27 A 442 050 02 27 A 442 050 03 27 A 442 050 04 27	<b>16146</b> <b>16150</b>
	[50]	∅ 12 mm				A 422 053 00 26	<b>LK-1610</b>
	IN/EX [6]	18,03 x 12 x 67,0	G2			A 422 053 04 30	<b>81-16100</b>
	IN [2] EX [2] EX [1] EX [1] EX [1]	61,11 x 51 x 9,0 53,11 x 43 x 9,2 53,11 x 43 x 9,2 53,31 x 43 x 9,4 53,51 x 43.2 x 9,6	G1 30° G1 45° G1 45° G1 45° G1 45°			A 403 053 03 31 A 442 053 00 32 A 422 053 01 32 A 442 053 01 32 A 442 053 02 32	<b>92-16163</b> <b>92-16127</b> <b>92-16126</b> <b>92-16149</b> <b>92-16128</b>
	724 mm					A 402 050 21 01 A 402 050 25 01 A 442 050 17 01	<b>20 1003 40201</b>
	[12] [12] [12]	M 31,5 x 76,5 x 20 M 32 x 76 x 20 M 32 x 76 x 20				A 403 054 09 01 A 403 054 18 01 A 422 050 03 25 A 476 050 00 25 A 422 050 03 25 A 476 050 00 25	<b>20 1003 40060</b> <b>20 1003 44000</b> (1) <b>20 1003 44001</b> <b>NEW</b> (2)
	(1) OES specification (2) IAM specification						

Fortsetzung nächste Seite / continued on next page / suite page suivante / continuación página próxima / Продолжение на следующей странице

					Reference	Item No.
[4]					A 403 050 07 33 A 442 050 03 33	20 1002 25010 (3)
[1]					A 403 050 03 33 A 403 050 07 33 A 442 050 03 33	20 1003 40010
[1]					A 403 050 03 33 A 403 050 07 33 A 442 050 03 33 A 442 055 00 20	20 1003 40012 (4)
(3)	nur 2-Ventiler/only 2 valves version/seulement 2 soupapes/sólo sistemas de 2 válvulas/заменяемо 2 Клапаны					
(4)	mit Einstellschraube/with adjusting screw/avec vis de réglage/con tornillo de ajuste/c установочным винтом					
	- - G - S -	- - -			A 402 010 03 20 A 403 010 40 20 A 403 010 89 20 A 427 010 00 20 A 427 010 10 20 A 429 010 02 20 A 442 010 07 20	20 0803 40300
	- V - G - S -	- - -	ready-to-install		A 427 010 10 20	20 0803 40301

**339**
**125**
**OM 402 Euro 1**
**980 - 981**

10.1990 →

 D (LA) 8 12760 cm<sup>3</sup> 2V

280 kW

(381 PS) 16,75:1 130,00 mm

93 231 6.., 94 656 6..

IN [1]	59,0 x 12 x 142,5	A/S - Cr -	- 30° - -	5 - III	A 403 053 09 01 A 422 050 00 26 A 422 050 02 26 A 422 050 05 26 A 422 053 01 01 A 423 050 00 26 A 442 050 02 26 A 442 050 03 26	16117
IN [1]	59,0 x 12 x 142,5	A/S - Cr -	- 30° - -	5 - III	A 442 050 05 26	16146
EX [1]	51,0 x 12 x 142,5	RA/S- Cr -	- 45° - -	5 - III	A 422 050 01 27 A 422 050 02 27 A 442 050 01 27 A 442 050 02 27 A 442 050 03 27 A 442 050 04 27	16150
[50]	Ø 12 mm				A 422 053 00 26	LK-1610
IN/EX [6]	18,03 x 12 x 67,0	G2			A 422 053 04 30	81-16100
Fortsetzung nächste Seite / continued on next page / suite page suivante / continuación página próxima / Продолжение на следующей странице						

					Reference	Item No.
	IN [2] EX [2] EX [1] EX [1] EX [1]	61,11 x 51 x 9,0 53,11 x 43 x 9,2 53,11 x 43 x 9,2 53,31 x 43 x 9,4 53,51 x 43.2 x 9,6	G1 30° G1 45° G1 45° G1 45° G1 45°		A 403 053 03 31 A 442 053 00 32 A 422 053 01 32 A 442 053 01 32 A 442 053 02 32	<b>92-16163</b> <b>92-16127</b> <b>92-16126</b> <b>92-16149</b> <b>92-16128</b>
	[12] [12]	M 32 x 76 x 20 M 32 x 76 x 20			A 422 050 03 25 A 476 050 00 25 A 422 050 03 25 A 476 050 00 25	<b>20 1003 44000</b> (1) <b>20 1003 44001</b> <b>NEW</b> (2)
	(1) OES specification (2) IAM specification					

## 340 125

OM 401 Euro 1

976

06.1992 →

D

(LA)

6

9570 cm<sup>3</sup> 2V

180 kW

(245 PS) 16,75:1 130,00 mm

93 231 6..., 94 656 6..

	IN [1]	59,0 x 12 x 142,5	A/S - Cr -	- 30° - -	5 - III	A 403 053 09 01 A 422 050 00 26 A 422 050 02 26 A 422 050 05 26 A 422 053 01 01 A 423 050 00 26 A 442 050 02 26 A 442 050 03 26	<b>16117</b>
	IN [1]	59,0 x 12 x 142,5	A/S - Cr -	- 30° - -	5 - III	A 442 050 05 26	<b>16146</b>
	IN [1]	59,0 x 12 x 142,5	S - Cr -	- 30° - VS -	5 - III	A 423 050 00 26	<b>1606</b>
	EX [1]	51,0 x 12 x 142,5	RA/S- Cr -	- 45° - -	5 - III	A 422 050 01 27 A 422 050 02 27 A 442 050 01 27 A 442 050 02 27 A 442 050 03 27 A 442 050 04 27	<b>16150</b>
	EX [1]	51,1 x 12 x 142,5	A/S - Cr -	- 45° - -	5 - III	A 423 050 04 27	<b>1608</b>
	[50] [50]	∅ 12 mm				A 000 053 04 26 A 422 053 00 26	<b>LK-1605</b> <b>LK-1610</b>
	IN/EX [6]	18,03 x 12 x 67,0	G2			A 422 053 04 30	<b>81-16100</b>
	IN [2] EX [2] EX [1] EX [1] EX [1]	61,11 x 51 x 9,0 53,11 x 43 x 9,2 53,11 x 43 x 9,2 53,31 x 43 x 9,4 53,51 x 43.2 x 9,6	G1 30° G1 45° G1 45° G1 45° G1 45°			A 403 053 03 31 A 442 053 00 32 A 422 053 01 32 A 442 053 01 32 A 442 053 02 32	<b>92-16163</b> <b>92-16127</b> <b>92-16126</b> <b>92-16149</b> <b>92-16128</b>
		566 mm				A 401 050 19 01 A 401 050 22 01 A 441 050 17 01	<b>20 1003 40101</b>
	[12] [12]	M 32 x 76 x 20 M 32 x 76 x 20				A 422 050 03 25 A 476 050 00 25 A 422 050 03 25 A 476 050 00 25	<b>20 1003 44000</b> (1) <b>20 1003 44001</b> <b>NEW</b> (2)
	(1) OES specification (2) IAM specification						

## 341 125

OM 470 Euro 6

903 - 904, 906 - 908, 910, 913 - 915, 917, 921

07.2011 →

D

(LA)

6

10677 cm<sup>3</sup> 4V

240-375 kW

(326-510 PS)

145,00 mm

Fortsetzung nächste Seite / continued on next page / suite page suivante / continuación página próxima / Продолжение на следующей странице



					Reference	Item No.		
	IN [2] EX [2]	42,5 x 9,5 x 240,0 40,0 x 9,5 x 246,5	RA/S- Cr - A/S - Cr -	- 20° - - - 30° - VS -	9 - III 9 - III	A 470 050 06 26 A 470 050 08 26 A 470 050 04 27 A 470 050 06 27	<b>162160</b> <small>NEW</small> <b>162170</b> <small>NEW</small>	
	[50]					A 472 053 00 26	<b>RK-9.5H</b>	
	IN/EX [1]	15,04 x 9.5 x 98,1	G2				<b>81-16110</b> <small>NEW</small>	
		ES AS				A 470 050 04 01 A 470 050 08 01 A 470 050 05 01 A 470 050 10 01	<b>20 1003 47000</b> <b>20 1003 47001</b>	
	EX [2] [2]					A 471 050 00 34 A 472 050 38 34 A 472 050 42 34	<b>20 1003 47111</b> <b>20 1003 47112</b> (1)	
	(1)	Motorbremse engine break frein moteur freno motor устройство для торможения двигателем						

## 342 125

<b>OM 470</b>	<b>946</b>	D (LA)	6	10677 cm <sup>3</sup>	4V	17	145,00 mm
<b>OM 470 Euro 6</b>	<b>902</b>	D (LA)	6	10677 cm <sup>3</sup>	4V	17,0:1	145,00 mm
<b>OM 470 LA Euro 6</b>		D (LA)	6	10677 cm <sup>3</sup>	4V	240-315 kW (326-428 PS)	17,0:1 145,00 mm
	05.2012 →	D (LA)	6	10677 cm <sup>3</sup>	4V	240-315 kW (326-428 PS)	17,0:1 145,00 mm

	IN/EX [1]	15,04 x 9.5 x 98,1	G2				<b>81-16110</b> <small>NEW</small>
--	-----------	--------------------	----	--	--	--	------------------------------------

## 343 125

<b>OM 401</b>	<b>901</b>	D (LA)	6	9570 cm <sup>3</sup>	2V	129-188 kW (175-256 PS)	0 130,00 mm
---------------	------------	--------	---	----------------------	----	-------------------------	-------------

		566 mm				A 401 050 19 01 A 401 050 22 01 A 441 050 17 01	<b>20 1003 40101</b>	
	[12]	M 32 x 76 x 20				A 422 050 03 25 A 476 050 00 25	<b>20 1003 44000</b> (1)	
	[12]	M 32 x 76 x 20				A 422 050 03 25 A 476 050 00 25	<b>20 1003 44001</b> <small>NEW</small> (2)	
	(1)	OES specification						
	(2)	IAM specification						

## 344 125

<b>OM 401</b>	<b>901/-000</b>	D	6	10456 cm <sup>3</sup>	2V		142,00 mm
---------------	-----------------	---	---	-----------------------	----	--	-----------

Fortsetzung nächste Seite / continued on next page / suite page suivante / continuación página próxima / Продолжение на следующей странице

M

					Reference	Item No.
	IN [1] 59,0 x 12 x 142,5	A/S - Cr -	- 30° - -	5 - III	A 403 053 09 01 A 422 050 00 26 A 422 050 02 26 A 422 050 05 26 A 422 053 01 01 A 423 050 00 26 A 442 050 02 26 A 442 050 03 26	<b>16117</b>
	IN [1] 59,0 x 12 x 142,5	A/S - Cr -	- 30° - -	5 - III	A 442 050 05 26	<b>16146</b>
	IN [1] 59,0 x 12 x 142,5	S - Cr -	- 30° - VS -	5 - III	A 423 050 00 26	<b>1606</b>
	EX [1] 51,0 x 12 x 142,5	A/S - Cr -	- 45° - -	5 - III	A 422 050 00 27	<b>16116</b>
	EX [1] 51,0 x 12 x 142,5	RA/S- Cr -	- 45° - -	5 - III	A 422 050 01 27 A 422 050 02 27 A 442 050 01 27 A 442 050 02 27 A 442 050 03 27 A 442 050 04 27	<b>16150</b>
	EX [1] 51,1 x 12 x 142,5	A/S - Cr -	- 45° - -	5 - III	A 423 050 04 27	<b>1608</b>
	[50]				A 000 053 04 26	<b>LK-1605</b>
	[50] Ø 12 mm				A 422 053 00 26	<b>LK-1610</b>
	IN/EX [6] 18,03 x 12 x 67,0	G2			A 422 053 04 30	<b>81-16100</b>
	IN [2] 60,11 x 51 x 8,9	G1 30°			A 403 053 09 31 A 403 053 15 31	<b>92-16100</b>
	IN [2] 61,11 x 51 x 9,0	G1 30°			A 403 053 03 31	<b>92-16163</b>
	IN [1] 60,31 x 51 x 9,1	G1 30°			A 403 053 10 31	<b>92-16147</b>
	IN [1] 60,51 x 51 x 9,3	G1 30°			A 403 053 11 31	<b>92-16101</b>
	EX [2] 53,11 x 43 x 9,2	G1 45°			A 442 053 00 32	<b>92-16127</b>
	EX [2] 53,11 x 43 x 9,7	G1 45°			A 403 053 00 32 A 403 053 03 32 A 403 053 21 32 A 403 053 25 32 A 403 053 28 32	<b>92-16104</b>
	EX [1] 53,11 x 43 x 9,2	G1 45°			A 422 053 01 32	<b>92-16126</b>
	EX [1] 53,31 x 43 x 9,4	G1 45°			A 442 053 01 32	<b>92-16149</b>
	EX [1] 53,31 x 43 x 9,9	G1 45°			A 403 053 01 32 A 403 053 13 32 A 403 053 22 32 A 403 053 26 32 A 403 053 29 32	<b>92-16148</b>
	EX [1] 53,51 x 43 x 10,2	G1 45°			A 403 053 02 32 A 403 053 23 32 A 403 053 27 32 A 403 053 30 32	<b>92-16105</b>
	EX [1] 53,51 x 43.2 x 9,6	G1 45°			A 442 053 02 32	<b>92-16128</b>
	[12] M 32 x 76 x 20				A 422 050 03 25 A 476 050 00 25	<b>20 1003 44000</b> (1)
	[12] M 32 x 76 x 20				A 422 050 03 25 A 476 050 00 25	<b>20 1003 44001</b> <b>NEW</b> (2)
	(1) OES specification					
	(2) IAM specification					

Fortsetzung nächste Seite / continued on next page / suite page suivante / continuación página próxima / Продолжение на следующей странице

					Reference	Item No.
[4]					A 403 050 07 33	20 1002 25010 (3)
[1]					A 442 050 03 33	20 1003 40010
[1]					A 403 050 03 33	
					A 403 050 07 33	20 1003 40012 (4)
					A 442 050 03 33	
					A 403 050 07 33	
					A 442 050 03 33	
					A 442 055 00 20	
(3)					nur 2-Ventiler/only 2 valves version/seulement 2 soupapes/sólo sistemas de 2 válvulas/заменяемо 2 Клапаны	
(4)					mit Einstellschraube/with adjusting screw/avec vis de réglage/con tornillo de ajuste/c установочным винтом	
	- - G - S -	- - - -			A 402 010 03 20	20 0803 40300
					A 403 010 40 20	
					A 403 010 89 20	
					A 427 010 00 20	
					A 427 010 10 20	
					A 429 010 02 20	
					A 442 010 07 20	
	- V - G - S -	- - - -	ready-to-install		A 427 010 10 20	20 0803 40301

**345**
**125**
**OM 402**
**901/-000**
**D 8 13941 cm<sup>3</sup> 2V**
**142,00 mm**

	IN [1]	59,0 x 12 x 142,5	A/S - Cr -	- 30° - -	5 - III	A 403 053 09 01 A 422 050 00 26 A 422 050 02 26 A 422 050 05 26 A 422 053 01 01 A 423 050 00 26 A 442 050 02 26 A 442 050 03 26	<b>16117</b>
	IN [1]	59,0 x 12 x 142,5	A/S - Cr -	- 30° - -	5 - III	A 442 050 05 26	<b>16146</b>
	IN [1]	59,0 x 12 x 142,5	S - Cr -	- 30° - VS -	5 - III	A 423 050 00 26	<b>1606</b>
	EX [1]	51,0 x 12 x 142,5	A/S - Cr -	- 45° - -	5 - III	A 422 050 00 27	<b>16116</b>
	EX [1]	51,0 x 12 x 142,5	RA/S- Cr -	- 45° - -	5 - III	A 422 050 01 27 A 422 050 02 27 A 442 050 01 27 A 442 050 02 27 A 442 050 03 27 A 442 050 04 27	<b>16150</b>
	EX [1]	51,1 x 12 x 142,5	A/S - Cr -	- 45° - -	5 - III	A 423 050 04 27	<b>1608</b>
	[50] [50]	Ø 12 mm				A 000 053 04 26 A 422 053 00 26	<b>LK-1605</b> <b>LK-1610</b>
	IN/EX [6]	18,03 x 12 x 67,0	G2			A 422 053 04 30	<b>81-16100</b>

Fortsetzung nächste Seite / continued on next page / suite page suivante / continuación página próxima / Продолжение на следующей странице

					Reference	Item No.
	IN [2]	60,11 x 51 x 8,9	G1 30°		A 403 053 09 31 A 403 053 15 31	<b>92-16100</b>
	IN [2]	61,11 x 51 x 9,0	G1 30°		A 403 053 03 31	<b>92-16163</b>
	IN [1]	60,31 x 51 x 9,1	G1 30°		A 403 053 10 31	<b>92-16147</b>
	IN [1]	60,51 x 51 x 9,3	G1 30°		A 403 053 11 31	<b>92-16101</b>
	EX [2]	53,11 x 43 x 9,2	G1 45°		A 442 053 00 32	<b>92-16127</b>
	EX [2]	53,11 x 43 x 9,7	G1 45°		A 403 053 00 32 A 403 053 03 32 A 403 053 21 32 A 403 053 25 32 A 403 053 28 32	<b>92-16104</b>
	EX [1]	53,11 x 43 x 9,2	G1 45°		A 422 053 01 32	<b>92-16126</b>
	EX [1]	53,31 x 43 x 9,4	G1 45°		A 442 053 01 32	<b>92-16149</b>
	EX [1]	53,31 x 43 x 9,9	G1 45°		A 403 053 01 32 A 403 053 13 32 A 403 053 22 32 A 403 053 26 32 A 403 053 29 32	<b>92-16148</b>
	EX [1]	53,51 x 43 x 10,2	G1 45°		A 403 053 02 32 A 403 053 23 32 A 403 053 27 32 A 403 053 30 32	<b>92-16105</b>
EX [1]	53,51 x 43.2 x 9,6	G1 45°		A 442 053 02 32	<b>92-16128</b>	
	724 mm				A 402 050 11 01 A 402 050 13 01 A 402 050 16 01 A 402 050 18 01	<b>20 1003 40200</b>
	724 mm				A 402 050 21 01 A 402 050 25 01 A 442 050 17 01	<b>20 1003 40201</b>
	[12]	M 32 x 76 x 20			A 422 050 03 25 A 476 050 00 25	<b>20 1003 44000</b> (1)
	[12]	M 32 x 76 x 20			A 422 050 03 25 A 476 050 00 25	<b>20 1003 44001</b> <span style="border: 1px solid black; padding: 1px;">NEW</span> (2)
	(1)	OES specification				
	(2)	IAM specification				
	[4]				A 403 050 07 33 A 442 050 03 33	<b>20 1002 25010</b> (3)
	[1]				A 403 050 03 33 A 403 050 07 33 A 442 050 03 33	<b>20 1003 40010</b>
	[1]				A 403 050 03 33 A 403 050 07 33 A 442 050 03 33 A 442 055 00 20	<b>20 1003 40012</b> (4)
	(3)	nur 2-Ventiler/only 2 valves version/seulement 2 soupapes/sólo sistemas de 2 válvulas/заменяемо 2 Клапаны				
	(4)	mit Einstellschraube/with adjusting screw/avec vis de réglage/con tornillo de ajuste/c установочным ВИНТОМ				
Fortsetzung nächste Seite / continued on next page / suite page suivante / continuación página próxima / Продолжение на следующей странице						

					Reference	Item No.
	- - G - S -	- - - -			A 402 010 03 20 A 403 010 40 20 A 403 010 89 20 A 427 010 00 20 A 427 010 10 20 A 429 010 02 20 A 442 010 07 20	<b>20 0803 40300</b>
	- V - G - S -	- - - -	ready-to-install		A 427 010 10 20	<b>20 0803 40301</b>

**346**
**125**
**OM 402 Euro 1**
**901/-504**
**D (LA) 8 12760 cm<sup>3</sup> 2V**
**130,00 mm**

93 231 6.., 94 656 6..

	IN [1]	59,0 x 12 x 142,5	A/S - Cr -	- 30° - -	5 - III	A 403 053 09 01 A 422 050 00 26 A 422 050 02 26 A 422 050 05 26 A 422 053 01 01 A 423 050 00 26 A 442 050 02 26 A 442 050 03 26	<b>16117</b>
	IN [1]	59,0 x 12 x 142,5	A/S - Cr -	- 30° - -	5 - III	A 442 050 05 26	<b>16146</b>
	IN [1]	59,0 x 12 x 142,5	S - Cr -	- 30° - VS -	5 - III	A 423 050 00 26	<b>1606</b>
	EX [1]	51,0 x 12 x 142,5	A/S - Cr -	- 45° - -	5 - III	A 422 050 00 27	<b>16116</b>
	EX [1]	51,0 x 12 x 142,5	RA/S- Cr -	- 45° - -	5 - III	A 422 050 01 27 A 422 050 02 27 A 442 050 01 27 A 442 050 02 27 A 442 050 03 27 A 442 050 04 27	<b>16150</b>
	EX [1]	51,1 x 12 x 142,5	A/S - Cr -	- 45° - -	5 - III	A 423 050 04 27	<b>1608</b>
	[50] [50]	Ø 12 mm				A 000 053 04 26 A 422 053 00 26	<b>LK-1605</b> <b>LK-1610</b>
	IN/EX [6]	18,03 x 12 x 67,0	G2			A 422 053 04 30	<b>81-16100</b>
	EX [2]	53,11 x 43 x 9,2	G1 45°			A 442 053 00 32	<b>92-16127</b>
	EX [1]	53,11 x 43 x 9,2	G1 45°			A 422 053 01 32	<b>92-16126</b>
	EX [1]	53,31 x 43 x 9,4	G1 45°			A 442 053 01 32	<b>92-16149</b>
	EX [1]	53,51 x 43.2 x 9,6	G1 45°			A 442 053 02 32	<b>92-16128</b>
		724 mm				A 402 050 21 01 A 402 050 25 01 A 442 050 17 01	<b>20 1003 40201</b>
	[12]	M 32 x 76 x 20				A 422 050 03 25 A 476 050 00 25	<b>20 1003 44000</b> (1)
	[12]	M 32 x 76 x 20				A 422 050 03 25 A 476 050 00 25	<b>20 1003 44001</b> <b>NEW</b> (2)
	(1)	OES specification					

Fortsetzung nächste Seite / continued on next page / suite page suivante / continuación página próxima / Продолжение на следующей странице



					Reference	Item No.
(2)	IAM specification					
[4]					A 403 050 07 33	<b>20 1002 25010</b> (3)
[1]					A 442 050 03 33	<b>20 1003 40010</b>
[1]					A 403 050 03 33	<b>20 1003 40012</b> (4)
					A 403 050 07 33	
					A 442 050 03 33	
					A 403 050 03 33	
					A 403 050 07 33	
					A 442 050 03 33	
					A 442 055 00 20	
(3)	nur 2-Ventiler/only 2 valves version/seulement 2 soupapes/sólo sistemas de 2 válvulas/заменяемо 2 Клапаны					
(4)	mit Einstellschraube/with adjusting screw/avec vis de réglage/con tornillo de ajuste/c установочным ВИНТОМ					
	- - G - S -	- - - -			A 402 010 03 20	<b>20 0803 40300</b>
					A 403 010 40 20	
					A 403 010 89 20	
					A 427 010 00 20	
					A 427 010 10 20	
					A 429 010 02 20	
					A 442 010 07 20	
	- V - G - S -	- - - -	ready-to-install		A 427 010 10 20	<b>20 0803 40301</b>

**347**

125









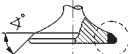

**OM 403**
**910-001, 910-002, 910-003, 910-004, 910-005, 910-006**

D 10 15960 cm<sup>3</sup> 2V 184-236 kW (250-320 PS) 17,2:1 130,00 mm

92 306 6..

	IN [1]	59,0 x 12 x 142,5	A/S - Cr -	- 30° - -	5 - III	A 403 053 09 01	<b>16117</b>
						A 422 050 00 26	
						A 422 050 02 26	
						A 422 050 05 26	
						A 422 053 01 01	
						A 423 050 00 26	
						A 442 050 02 26	
						A 442 050 03 26	
	IN [1]	59,0 x 12 x 142,5	A/S - Cr -	- 30° - -	5 - III	A 442 050 05 26	<b>16146</b>
	IN [1]	59,0 x 12 x 142,5	S - Cr -	- 30° - VS -	5 - III	A 423 050 00 26	<b>1606</b>
	EX [1]	51,0 x 12 x 142,5	A/S - Cr -	- 45° - -	5 - III	A 422 050 00 27	<b>16116</b>
	EX [1]	51,0 x 12 x 142,5	RA/S- Cr -	- 45° - -	5 - III	A 422 050 01 27	<b>16150</b>
						A 422 050 02 27	
						A 442 050 01 27	
						A 442 050 02 27	
						A 442 050 03 27	
						A 442 050 04 27	
	[50]					A 000 053 04 26	<b>LK-1605</b>
	[50]	∅ 12 mm				A 422 053 00 26	<b>LK-1610</b>

Fortsetzung nächste Seite / continued on next page / suite page suivante / continuación página próxima / Продолжение на следующей странице

					Reference	Item No.
 IN/EX [6]	18,03 x 12 x 67,0	G2			A 422 053 04 30	81-16100
 IN [2]	60,11 x 51 x 8,9	G1 30°			A 403 053 09 31 A 403 053 15 31	92-16100
IN [2]	61,11 x 51 x 9,0	G1 30°			A 403 053 03 31	92-16163
IN [1]	60,31 x 51 x 9,1	G1 30°			A 403 053 10 31	92-16147
IN [1]	60,51 x 51 x 9,3	G1 30°			A 403 053 11 31	92-16101
EX [2]	53,11 x 43 x 9,7	G1 45°			A 403 053 00 32 A 403 053 03 32 A 403 053 21 32 A 403 053 25 32 A 403 053 28 32	92-16104
EX [1]	53,31 x 43 x 9,9	G1 45°			A 403 053 01 32 A 403 053 13 32 A 403 053 22 32 A 403 053 26 32 A 403 053 29 32	92-16148
EX [1]	53,51 x 43 x 10,2	G1 45°			A 403 053 02 32 A 403 053 23 32 A 403 053 27 32 A 403 053 30 32	92-16105
 [12]	M 32 x 76 x 20				A 422 050 03 25 A 476 050 00 25	20 1003 44000 (1)
[12]	M 32 x 76 x 20				A 422 050 03 25 A 476 050 00 25	20 1003 44001 <b>NEW</b> (2)
	(1) OES specification					
	(2) IAM specification					
	- - G - S -	- - -			A 402 010 03 20 A 403 010 40 20 A 403 010 89 20 A 427 010 00 20 A 427 010 10 20 A 429 010 02 20 A 442 010 07 20	20 0803 40300
	- V - G - S -	- - -	ready-to-install		A 427 010 10 20	20 0803 40301
						

**348**  **125**

<b>OM 407</b>	<b>952 - 953, 956</b>	D (A)	6	11413 cm <sup>3</sup>	2V	206 kW	(280 PS)	16,5:1	155,00 mm
<b>OM 407</b>	<b>954</b>	D (LA)	6	11413 cm <sup>3</sup>	2V	235 kW	(320 PS)	16,5:1	155,00 mm

93 585 6..

Fortsetzung nächste Seite / continued on next page / suite page suivante / continuación página próxima / Продолжение на следующей странице

					Reference	Item No.
	IN [1] 59,0 x 12 x 142,5	A/S - Cr -	- 30° - -	5 - III	A 403 053 09 01 A 422 050 00 26 A 422 050 02 26 A 422 050 05 26 A 422 053 01 01 A 423 050 00 26 A 442 050 02 26 A 442 050 03 26	<b>16117</b>
	IN [1] 59,0 x 12 x 142,5	A/S - Cr -	- 30° - -	5 - III	A 442 050 05 26	<b>16146</b>
	IN [1] 59,0 x 12 x 142,5	S - Cr -	- 30° - VS -	5 - III	A 423 050 00 26	<b>1606</b>
	EX [1] 51,0 x 12 x 142,5	RA/S- Cr -	- 45° - -	5 - III	A 422 050 01 27 A 422 050 02 27 A 442 050 01 27 A 442 050 02 27 A 442 050 03 27 A 442 050 04 27	<b>16150</b>
	EX [1] 51,1 x 12 x 142,5	A/S - Cr -	- 45° - -	5 - III	A 423 050 04 27	<b>1608</b>
	[50] [50] Ø 12 mm				A 000 053 04 26 A 422 053 00 26	<b>LK-1605</b> <b>LK-1610</b>
	IN/EX [6] IN/EX [6] IN/EX [6] 18,03 x 12 x 67,0 18,03 x 12 x 67,0 18,23 x 12 x 67,0	G1 G2 G1			A 403 053 00 30 A 422 053 04 30 A 403 053 01 30	<b>81-1647</b> <b>81-16100</b> <b>81-1648</b>
	IN [2] IN [2] IN [2] IN [2] IN [1] IN [1] IN [1] EX [2] EX [2] 60,11 x 51 x 8,9 60,11 x 51.2 x 8,4 61,11 x 51 x 9,0 60,31 x 51 x 9,1 60,31 x 51.2 x 8,6 60,51 x 51 x 9,3 53,11 x 43 x 9,2 53,11 x 43 x 9,7	G1 30° G1 30° G1 30° G1 30° G1 30° G1 30° G1 45° G1 45°			A 403 053 09 31 A 403 053 15 31 A 422 053 05 31 A 403 053 03 31 A 403 053 10 31 A 422 053 06 31 A 403 053 11 31 A 442 053 00 32 A 403 053 00 32 A 403 053 03 32 A 403 053 21 32 A 403 053 25 32 A 403 053 28 32	<b>92-16100</b> <b>92-16151</b> <b>92-16163</b> <b>92-16147</b> <b>92-16152</b> <b>92-16101</b> <b>92-16127</b> <b>92-16104</b>
	EX [1] EX [1] EX [1] 53,11 x 43 x 9,2 53,31 x 43 x 9,4 53,31 x 43 x 9,9	G1 45° G1 45° G1 45°			A 422 053 01 32 A 442 053 01 32 A 403 053 01 32 A 403 053 13 32 A 403 053 22 32 A 403 053 26 32 A 403 053 29 32	<b>92-16126</b> <b>92-16149</b> <b>92-16148</b>
	EX [1] 53,51 x 43 x 10,2	G1 45°			A 403 053 02 32 A 403 053 23 32 A 403 053 27 32 A 403 053 30 32	<b>92-16105</b>
	EX [1] 53,51 x 43.2 x 9,6	G1 45°			A 442 053 02 32	<b>92-16128</b>

Fortsetzung nächste Seite / continued on next page / suite page suivante / continuación página próxima / Продолжение на следующей странице

					Reference	Item No.
	- - G - S -	- - - -			A 402 010 03 20 A 403 010 40 20 A 403 010 89 20 A 427 010 00 20 A 427 010 10 20 A 429 010 02 20 A 442 010 07 20	<b>20 0803 40300</b>
	- V - G - S -	- - - -	ready-to-install		A 427 010 10 20	<b>20 0803 40301</b>

**349**
**125**
**OM 409**
**906 - 908**

D (NA) 5 9204 cm<sup>3</sup> 2V 135 kW (184 PS) 17:1 150,00 mm

93 298 6..

**M**

	IN [1]	59,0 x 12 x 142,5	A/S - Cr -	- 30° - -	5 - III	A 403 053 09 01 A 422 050 00 26 A 422 050 02 26 A 422 050 05 26 A 422 053 01 01 A 423 050 00 26 A 442 050 02 26 A 442 050 03 26	<b>16117</b>
	IN [1]	59,0 x 12 x 142,5	A/S - Cr -	- 30° - -	5 - III	A 442 050 05 26	<b>16146</b>
	IN [1]	59,0 x 12 x 142,5	S - Cr -	- 30° - VS -	5 - III	A 423 050 00 26	<b>1606</b>
	EX [1]	51,0 x 12 x 142,5	A/S - Cr -	- 45° - -	5 - III	A 422 050 00 27	<b>16116</b>
	EX [1]	51,0 x 12 x 142,5	RA/S- Cr -	- 45° - -	5 - III	A 422 050 01 27 A 422 050 02 27 A 442 050 01 27 A 442 050 02 27 A 442 050 03 27 A 442 050 04 27	<b>16150</b>
	EX [1]	51,1 x 12 x 142,5	A/S - Cr -	- 45° - -	5 - III	A 423 050 04 27	<b>1608</b>
	[50]					A 000 053 04 26	<b>LK-1605</b>
	[50]	Ø 12 mm				A 422 053 00 26	<b>LK-1610</b>
	IN/EX [6]	18,03 x 12 x 67,0	G1			A 403 053 00 30	<b>81-1647</b>
	IN/EX [6]	18,03 x 12 x 67,0	G2			A 422 053 04 30	<b>81-16100</b>
	IN/EX [6]	18,23 x 12 x 67,0	G1			A 403 053 01 30	<b>81-1648</b>

Fortsetzung nächste Seite / continued on next page / suite page suivante / continuación página próxima / Продолжение на следующей странице

					Reference	Item No.
IN [2]	60,11 x 51 x 8,9	G1 30°			A 403 053 09 31 A 403 053 15 31	<b>92-16100</b>
IN [2]	60,11 x 51.2 x 8,4	G1 30°			A 422 053 05 31	<b>92-16151</b>
IN [1]	60,31 x 51 x 9,1	G1 30°			A 403 053 10 31	<b>92-16147</b>
IN [1]	60,31 x 51.2 x 8,6	G1 30°			A 422 053 06 31	<b>92-16152</b>
IN [1]	60,51 x 51 x 9,3	G1 30°			A 403 053 11 31	<b>92-16101</b>
EX [2]	53,11 x 43 x 9,2	G1 45°			A 442 053 00 32	<b>92-16127</b>
EX [2]	53,11 x 43 x 9,7	G1 45°			A 403 053 00 32 A 403 053 03 32 A 403 053 21 32 A 403 053 25 32 A 403 053 28 32	<b>92-16104</b>
EX [1]	53,11 x 43 x 9,2	G1 45°			A 422 053 01 32	<b>92-16126</b>
EX [1]	53,31 x 43 x 9,4	G1 45°			A 442 053 01 32	<b>92-16149</b>
EX [1]	53,31 x 43 x 9,9	G1 45°			A 403 053 01 32 A 403 053 13 32 A 403 053 22 32 A 403 053 26 32 A 403 053 29 32	<b>92-16148</b>
EX [1]	53,51 x 43 x 10,2	G1 45°			A 403 053 02 32 A 403 053 23 32 A 403 053 27 32 A 403 053 30 32	<b>92-16105</b>
EX [1]	53,51 x 43.2 x 9,6	G1 45°			A 442 053 02 32	<b>92-16128</b>
	- - G - S -	- - -			A 402 010 03 20 A 403 010 40 20 A 403 010 89 20 A 427 010 00 20 A 427 010 10 20 A 429 010 02 20 A 442 010 07 20	<b>20 0803 40300</b>
	- V - G - S -	- - -	ready-to-install		A 427 010 10 20	<b>20 0803 40301</b>

**350**

125

**OM 470**
**918**

D (LA) 6 10677 cm³ 4V

17

145,00 mm

IN/EX [1]	15,04 x 9.5 x 98,1	G2				<b>81-16110</b>
	ES				A 470 050 04 01 A 470 050 08 01	<b>20 1003 47000</b>
	AS				A 470 050 05 01 A 470 050 10 01	<b>20 1003 47001</b>
EX [2] [2]					A 471 050 00 34 A 472 050 38 34 A 472 050 42 34	<b>20 1003 47111</b> <b>20 1003 47112</b> (1)
(1)	Motorbremse engine break frein moteur freno motor устройство для торможения двигателем					



					Reference	Item No.	
<b>351</b>		<b>125</b>					
<b>OM 470 Euro 6</b>	<b>922</b>						
		D (LA)	6	10677 cm <sup>3</sup>	4V	240-335 kW (326-456 PS) 17	145,00 mm
	IN [2]	42,5 x 9,5 x 240,0	RA/S- Cr -	- 20° -	- 9 - III	A 470 050 06 26 A 470 050 08 26	<b>162160</b>
	EX [2]	40,0 x 9,5 x 246,5	A/S - Cr -	- 30° - VS -	9 - III	A 470 050 04 27 A 470 050 06 27	<b>162170</b>
	[50]					A 472 053 00 26	<b>RK-9.5H</b>
	IN/EX [1]	15,04 x 9.5 x 98,1	G2				<b>81-16110</b>
		ES				A 470 050 04 01 A 470 050 08 01	<b>20 1003 47000</b>
		AS				A 470 050 05 01 A 470 050 10 01	<b>20 1003 47001</b>
<b>352</b>		<b>125</b>					
<b>OM 470 Euro 6</b>	<b>923</b>						
		D (LA)	6	10677 cm <sup>3</sup>	4V	240-335 kW (326-456 PS) 17	145,00 mm
	IN [2]	42,5 x 9,5 x 240,0	RA/S- Cr -	- 20° -	- 9 - III	A 470 050 06 26 A 470 050 08 26	<b>162160</b>
	EX [2]	40,0 x 9,5 x 246,5	A/S - Cr -	- 30° - VS -	9 - III	A 470 050 04 27 A 470 050 06 27	<b>162170</b>
	[50]					A 472 053 00 26	<b>RK-9.5H</b>
	IN/EX [1]	15,04 x 9.5 x 98,1	G2				<b>81-16110</b>
		ES				A 470 050 04 01 A 470 050 08 01	<b>20 1003 47000</b>
		AS				A 470 050 05 01 A 470 050 10 01	<b>20 1003 47001</b>
	EX [2]					A 471 050 00 34	<b>20 1003 47111</b>
<b>353</b>		<b>128</b>					
<b>OM 447</b>	<b>915 - 916</b>						
		AL (NA)	6	11967 cm <sup>3</sup>	2V	185 kW (252 PS) 18:1	155,00 mm
	IN [1]	59,0 x 12 x 142,5	A/S - Cr -	- 30° -	- 5 - III	A 403 053 09 01 A 422 050 00 26 A 422 050 02 26 A 422 050 05 26 A 422 053 01 01 A 423 050 00 26 A 442 050 02 26 A 442 050 03 26	<b>16117</b>
	IN [1]	59,0 x 12 x 142,5	A/S - Cr -	- 30° -	- 5 - III	A 442 050 05 26	<b>16146</b>
	EX [1]	51,0 x 12 x 142,5	A/S - Cr -	- 45° -	- 5 - III	A 422 050 00 27	<b>16116</b>
	EX [1]	51,0 x 12 x 142,5	RA/S- Cr -	- 45° -	- 5 - III	A 422 050 01 27 A 422 050 02 27 A 442 050 01 27 A 442 050 02 27 A 442 050 03 27 A 442 050 04 27	<b>16150</b>
	[50]	Ø 12 mm				A 422 053 00 26	<b>LK-1610</b>
Fortsetzung nächste Seite / continued on next page / suite page suivante / continuación página próxima / Продолжение на следующей странице							

M

					Reference	Item No.
	IN/EX [6] 18,03 x 12 x 67,0 IN/EX [6] 18,03 x 12 x 67,0 IN/EX [6] 18,23 x 12 x 67,0	G1 G2 G1			A 403 053 00 30 A 422 053 04 30 A 403 053 01 30	<b>81-1647</b> <b>81-16100</b> <b>81-1648</b>
	[12] M 31,5 x 76,5 x 20 [12] M 32 x 76 x 20 [12] M 32 x 76 x 20 (1) OES specification (2) IAM specification				A 403 054 09 01 A 403 054 18 01 A 422 050 03 25 A 476 050 00 25 A 422 050 03 25 A 476 050 00 25	<b>20 1003 40060</b> <b>20 1003 44000</b> (1) <b>20 1003 44001</b> <b>NEW</b> (2)
	[4] [1] [1] (3) nur 2-Ventiler/only 2 valves version/seulement 2 soupapes/sólo sistemas de 2 válvulas/заменяемо 2 Клапаны (4) mit Einstellschraube/with adjusting screw/avec vis de réglage/con tornillo de ajuste/c установочным ВИНТОМ				A 403 050 07 33 A 442 050 03 33 A 403 050 03 33 A 403 050 07 33 A 442 050 03 33 A 403 050 03 33 A 403 050 07 33 A 442 050 03 33 A 442 055 00 20	<b>20 1002 25010</b> (3) <b>20 1003 40010</b> <b>20 1003 40012</b> (4)

**354**
**128**
**M 447**
**925**

12.1984 →

G

6

 11970 cm<sup>3</sup> 2V

150 kW

(204 PS) 18:1

155,00 mm

40 249 6..

	IN [1] 58,9 x 12 x 142,5 EX [1] 51,0 x 12 x 142,5	RA/S- Cr - RA/S- Ni -	- 20° - - 20° - VS -	5 - III 5 - III	A 442 050 01 26 A 442 050 06 26 A 442 050 07 26 A 407 050 01 27 A 447 050 00 27 A 447 050 03 27	<b>16202</b> <b>162031</b>
	[50] Ø 12 mm				A 422 053 00 26	<b>LK-1610</b>
	IN/EX [6] 18,03 x 12 x 67,0	G2			A 422 053 04 30	<b>81-16100</b>
	IN [1] 60,10 x 51 x 8,3 EX [1] 53,11 x 43 x 8,4	G2 20° G2 20°			A 407 053 04 31 A 447 053 08 32	<b>92-16161</b> <b>92-16162</b>
	[12] M 32 x 76 x 20 (1) OES specification				A 422 050 03 25 A 476 050 00 25	<b>20 1003 44000</b> (1)
	[4] [1] [1] (2) nur 2-Ventiler/only 2 valves version/seulement 2 soupapes/sólo sistemas de 2 válvulas/заменяемо 2 Клапаны (3) mit Einstellschraube/with adjusting screw/avec vis de réglage/con tornillo de ajuste/c установочным ВИНТОМ				A 403 050 07 33 A 442 050 03 33 A 403 050 03 33 A 403 050 07 33 A 442 050 03 33 A 403 050 03 33 A 403 050 07 33 A 442 050 03 33 A 442 055 00 20	<b>20 1002 25010</b> (2) <b>20 1003 40010</b> <b>20 1003 40012</b> (3)

					Reference	Item No.		
<b>355</b>		<b>128</b>						
<b>M 476</b>	<b>925 - 927</b>							
40 249 6..	11.1985→	G (LA)	6	11967 cm <sup>3</sup>	2V	177 kW (241 PS)	155,00 mm	
	IN [1]	58,9 x 12 x 142,5	RA/S- Cr -	- 20° -	-	5 - III	A 442 050 01 26 A 442 050 06 26 A 442 050 07 26	<b>16202</b>
	EX [1]	51,0 x 12 x 142,5	RA/S- Ni -	- 20° - VS -		5 - III	A 407 050 01 27 A 447 050 00 27 A 447 050 03 27	<b>162031</b>
	[50]	Ø 12 mm					A 422 053 00 26	<b>LK-1610</b>
	IN/EX [6]	18,03 x 12 x 67,0	G2				A 422 053 04 30	<b>81-16100</b>
	IN [1]	60,10 x 51 x 8,3	G2 20°				A 407 053 04 31	<b>92-16161</b>
	EX [1]	53,11 x 43 x 8,4	G2 20°				A 447 053 08 32	<b>92-16162</b>
	[12]	M 32 x 76 x 20					A 422 050 03 25 A 476 050 00 25	<b>20 1003 44000</b> (1)
	[12]	M 32 x 76 x 20					A 422 050 03 25 A 476 050 00 25	<b>20 1003 44001</b> (2)
	(1)	OES specification						
	(2)	IAM specification						
<b>356</b>		<b>128</b>						
<b>M 476</b>	<b>920 - 921</b>							
		G (LA)	6	11967 cm <sup>3</sup>	2V	175-177 kW (238-241 PS)	155,00 mm	
<b>M 476 Euro 2</b>	<b>930, 932 - 935</b>							
40 249 6.., 40 250 6..	04.2000→	G (LA)	6	11967 cm <sup>3</sup>	2V	185-240 kW (252-326 PS)	155,00 mm	
	IN [1]	58,9 x 12 x 142,5	RA/S- Cr -	- 20° -	-	5 - III	A 442 050 01 26 A 442 050 06 26 A 442 050 07 26	<b>16202</b>
	EX [1]	51,0 x 12 x 142,5	RA/S- Ni -	- 20° - VS -		5 - III	A 407 050 01 27 A 447 050 00 27 A 447 050 03 27	<b>162031</b>
	[50]	Ø 12 mm					A 422 053 00 26	<b>LK-1610</b>
	IN/EX [6]	18,03 x 12 x 67,0	G2				A 422 053 04 30	<b>81-16100</b>
	IN [1]	60,10 x 51 x 8,3	G2 20°				A 407 053 04 31	<b>92-16161</b>
	EX [1]	53,11 x 43 x 8,4	G2 20°				A 447 053 08 32	<b>92-16162</b>
	[12]	M 32 x 76 x 20					A 422 050 03 25 A 476 050 00 25	<b>20 1003 44000</b> (1)
	(1)	OES specification						
<b>357</b>		<b>128</b>						
<b>M 476 Euro 2</b>	<b>936</b>							
		G (LA)	6	11967 cm <sup>3</sup>	2V	175 kW (238 PS)	155,00 mm	
	[12]	M 32 x 76 x 20					A 422 050 03 25 A 476 050 00 25	<b>20 1003 44000</b> (1)
	(1)	OES specification						

M

					Reference	Item No.	
<b>358</b>	<b>128</b>	<b>M 476 Euro 2 937</b>					
		G (LA) 6	11967 cm <sup>3</sup> 2V	185 kW	(252 PS)	155,00 mm	
	IN/EX [6]	18,03 x 12 x 67,0	G2		A 422 053 04 30	<b>81-16100</b>	
	IN [1] EX [1]	60,10 x 51 x 8,3 53,11 x 43 x 8,4	G2 20° G2 20°		A 407 053 04 31 A 447 053 08 32	<b>92-16161</b> <b>92-16162</b>	
	[12]	M 32 x 76 x 20			A 422 050 03 25 A 476 050 00 25	<b>20 1003 44000</b> (1)	
		(1) OES specification					
<b>359</b>	<b>128</b>	<b>OM 355 960 - 964, 966 - 967, 970, 972 - 976, 979 - 982</b>					
		01.1959 →	D (NA) 6	11581 cm <sup>3</sup> 4V	136-191 kW	(185-260 PS) 150,00 mm	
93 568 6..							
	IN [2]	42,0 x 9 x 129,8	S - Cr -	- 45° -	- 5 - III	A 345 053 71 01 A 346 053 00 01 A 346 053 01 01 A 346 053 03 01	<b>1657</b>
	EX [2]	37,0 x 9 x 165,3	A/S - Cr -	- 45° -	- 5 - III	A 345 053 71 05 A 346 053 01 05 A 346 053 02 05 A 355 050 01 27	<b>1658</b>
	IN [6]	15,04 x 9 x 68,5	G1			A 346 053 09 29	<b>81-1640</b>
	IN [4]	15,20 x 9 x 67,5	G1			A 346 053 11 29	<b>81-1642</b>
	EX [6]	15,00 x 9 x 86,5	G1			A 355 053 03 30	<b>81-1641</b>
	IN [2]	51,06 x 37 x 7,5	G1 45°			A 346 053 07 31 A 355 053 11 31	<b>92-16106</b>
	IN [1]	51,26 x 37 x 7,5	G1 45°			A 346 053 08 31	<b>92-16140</b>
	IN [1]	51,46 x 37 x 7,5	G1 45°			A 355 053 09 31 A 355 053 13 31	<b>92-16142</b>
	EX [2]	40,10 x 31 x 7,5	G1 45°			A 345 053 01 32 A 346 053 05 32 A 355 053 06 32 A 355 053 10 32 A 355 053 18 32	<b>92-16110</b>
	EX [1]	40,46 x 31 x 7,5	G1 45°			A 355 053 12 32 A 355 053 20 32	<b>92-16143</b>
		1105 mm				A 355 051 04 01	<b>20 1003 35500</b>
	[12]	M 34 x 70				A 345 054 70 01 A 346 054 02 01 A 355 054 01 01	<b>20 1003 35560</b>
<b>360</b>	<b>128</b>	<b>OM 346 951</b>					
		1961 → 1967	D (A) 6	10809 cm <sup>3</sup> 4V		140,00 mm	
	IN [2]	42,0 x 9 x 129,8	S - Cr -	- 45° -	- 5 - III	A 345 053 71 01 A 346 053 00 01 A 346 053 01 01 A 346 053 03 01	<b>1657</b>
	EX [2]	37,0 x 9 x 165,3	A/S - Cr -	- 45° -	- 5 - III	A 345 053 71 05 A 346 053 01 05 A 346 053 02 05 A 355 050 01 27	<b>1658</b>
Fortsetzung nächste Seite / continued on next page / suite page suivante / continuación página próxima / Продолжение на следующей странице							

						Reference	Item No.
	IN [6] IN [4] EX [6]	15,04 x 9 x 68,5 15,20 x 9 x 67,5 15,00 x 9 x 86,5	G1 G1 G1			A 346 053 09 29 A 346 053 11 29 A 355 053 03 30	<b>81-1640</b> <b>81-1642</b> <b>81-1641</b>
	IN [2] IN [1] EX [2] EX [1]	51,06 x 37 x 7,5 51,46 x 37 x 7,5 40,10 x 31 x 7,5 40,46 x 31 x 7,5	G1 45° G1 45° G1 45° G1 45°			A 346 053 07 31 A 355 053 11 31 A 355 053 09 31 A 355 053 13 31 A 345 053 01 32 A 346 053 05 32 A 355 053 06 32 A 355 053 10 32 A 355 053 18 32 A 355 053 12 32 A 355 053 20 32	<b>92-16106</b> <b>92-16142</b> <b>92-16110</b> <b>92-16143</b>
		1105 mm				A 355 051 10 01	<b>20 1003 35501</b>
	[12]	M 34 x 70				A 345 054 70 01 A 346 054 02 01 A 355 054 01 01	<b>20 1003 35560</b>

## 361 128

<b>OM 346</b>	<b>911, 918, 946</b>	01.1966 → 01.1976	D (NA)	6	10809 cm <sup>3</sup>	4V	132-155 kW	(180-210 PS)	17,5:1	140,00 mm
<b>OM 346</b>	<b>910, 912 - 917, 919, 940 - 945, 947, 952 - 953</b>	1961 →	D (NA)	6	10809 cm <sup>3</sup>	2V	132-155 kW	(180-210 PS)		140,00 mm
<b>OM 355</b>	<b>916</b>	1967 → 1978	D (NA)	6	11581 cm <sup>3</sup>	2V	169 kW	(230 PS)	17,2:1	150,00 mm

93 568 6..

	IN [2] EX [2]	42,0 x 9 x 129,8 37,0 x 9 x 165,3	S - Cr - A/S - Cr -	- 45° - - 45° -	- -	5 - III 5 - III	A 345 053 71 01 A 346 053 00 01 A 346 053 01 01 A 346 053 03 01 A 345 053 71 05 A 346 053 01 05 A 346 053 02 05 A 355 050 01 27	<b>1657</b> <b>1658</b>
	IN [6] IN [4] EX [6]	15,04 x 9 x 68,5 15,20 x 9 x 67,5 15,00 x 9 x 86,5	G1 G1 G1				A 346 053 09 29 A 346 053 11 29 A 355 053 03 30	<b>81-1640</b> <b>81-1642</b> <b>81-1641</b>
	IN [2] IN [1] EX [2] EX [1]	51,06 x 37 x 7,5 51,46 x 37 x 7,5 40,10 x 31 x 7,5 40,46 x 31 x 7,5	G1 45° G1 45° G1 45° G1 45°				A 346 053 07 31 A 355 053 11 31 A 355 053 09 31 A 355 053 13 31 A 345 053 01 32 A 346 053 05 32 A 355 053 06 32 A 355 053 10 32 A 355 053 18 32 A 355 053 12 32 A 355 053 20 32	<b>92-16106</b> <b>92-16142</b> <b>92-16110</b> <b>92-16143</b>
	[12]	M 34 x 70					A 345 054 70 01 A 346 054 02 01 A 355 054 01 01	<b>20 1003 35560</b>

## 362 128

<b>OM 481</b>	<b>904</b>	11.1964 → 12.1975	D (NA)	6	10964 cm <sup>3</sup>	2V	159 kW	(216 PS)	16,9:1	142,00 mm
---------------	------------	-------------------	--------	---	-----------------------	----	--------	----------	--------	-----------







93 484 6.., 93 484 7..

Fortsetzung nächste Seite / continued on next page / suite page suivante / continuación página próxima / Продолжение на следующей странице

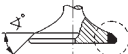

					Reference	Item No.
	IN [1] 59,0 x 12 x 142,5	A/S - Cr -	- 30° - -	5 - III	A 403 053 09 01 A 422 050 00 26 A 422 050 02 26 A 422 050 05 26 A 422 053 01 01 A 423 050 00 26 A 442 050 02 26 A 442 050 03 26	<b>16117</b>
	IN [1] EX [1] 59,0 x 12 x 142,5 51,0 x 12 x 142,5	A/S - Cr - RA/S- Cr -	- 30° - - - 45° - -	5 - III 5 - III	A 442 050 05 26 A 422 050 01 27 A 422 050 02 27 A 442 050 01 27 A 442 050 02 27 A 442 050 03 27 A 442 050 04 27	<b>16146</b> <b>16150</b>
	[50] Ø 12 mm				A 422 053 00 26	<b>LK-1610</b>
	IN/EX [6] IN/EX [6] IN/EX [6] 18,03 x 12 x 67,0 18,03 x 12 x 67,0 18,23 x 12 x 67,0	G1 G2 G1			A 403 053 00 30 A 422 053 04 30 A 403 053 01 30	<b>81-1647</b> <b>81-16100</b> <b>81-1648</b>
	IN [2] IN [1] IN [1] IN [1] EX [2] EX [2] 60,11 x 51 x 8,9 60,11 x 49.3 x 8,4 60,31 x 51 x 9,1 60,51 x 51 x 9,3 53,11 x 43 x 9,2 53,11 x 43 x 9,7	G1 30° G1 30° G1 30° G1 30° G1 45° G1 45°			A 403 053 09 31 A 403 053 15 31 A 422 053 01 31 A 447 053 00 31 A 403 053 10 31 A 403 053 11 31 A 442 053 00 32 A 403 053 00 32 A 403 053 03 32 A 403 053 21 32 A 403 053 25 32 A 403 053 28 32	<b>92-16100</b> <b>92-16150</b> <b>92-16147</b> <b>92-16101</b> <b>92-16127</b> <b>92-16104</b>
	EX [1] EX [1] EX [1] 53,11 x 43 x 9,2 53,31 x 43 x 9,4 53,31 x 43 x 9,9	G1 45° G1 45° G1 45°			A 422 053 01 32 A 442 053 01 32 A 403 053 01 32 A 403 053 13 32 A 403 053 22 32 A 403 053 26 32 A 403 053 29 32	<b>92-16126</b> <b>92-16149</b> <b>92-16148</b>
	EX [1] 53,51 x 43 x 10,2	G1 45°			A 403 053 02 32 A 403 053 23 32 A 403 053 27 32 A 403 053 30 32	<b>92-16105</b>
	EX [1] 53,51 x 43.2 x 9,6	G1 45°			A 442 053 02 32	<b>92-16128</b>
	[12] M 32 x 76 x 20				A 422 050 03 25 A 476 050 00 25	<b>20 1003 44000</b> (1)
	[12] M 32 x 76 x 20				A 422 050 03 25 A 476 050 00 25	<b>20 1003 44001</b> <b>NEW</b> (2)
	(1) OES specification (2) IAM specification					
	[1] [1]				A 403 050 03 33 A 403 050 07 33 A 442 050 03 33 A 403 050 03 33 A 403 050 07 33 A 442 050 03 33 A 442 055 00 20	<b>20 1003 40010</b> <b>20 1003 40012</b> (3)
	(3) mit Einstellschraube/with adjusting screw/avec vis de réglage/con tornillo de ajuste/c установочным винтом					

Fortsetzung nächste Seite / continued on next page / suite page suivante / continuación página próxima / Продолжение на следующей странице

					Reference	Item No.
	- - G - S -	- - - -			A 402 010 03 20 A 403 010 40 20 A 403 010 89 20 A 427 010 00 20 A 427 010 10 20 A 429 010 02 20 A 442 010 07 20	20 0803 40300
						
	- V - G - S -	- - - -	ready-to-install		A 427 010 10 20	20 0803 40301
						

**363**  **128**

OM 345	<b>900, 915, 941, 945 - 947</b>								
	01.1966 →	D (NA)	5	9651 cm <sup>3</sup>	4V	125-141 kW	(170-192 PS)	17,2:1	150,00 mm
OM 345	<b>919 (BRA)</b>	D	5	9651 cm <sup>3</sup>	2V	114 kW	(155 PS)	17,2:1	150,00 mm
93 568 6..									

	IN [2]	51,06 x 37 x 7,5	G1 45°			A 346 053 07 31 A 355 053 11 31	92-16106
	IN [1]	51,26 x 37 x 7,5	G1 45°			A 346 053 08 31	92-16140
	IN [1]	51,46 x 37 x 7,5	G1 45°			A 355 053 09 31 A 355 053 13 31	92-16142
	EX [2]	40,10 x 31 x 7,5	G1 45°			A 345 053 01 32 A 346 053 05 32 A 355 053 06 32 A 355 053 10 32 A 355 053 18 32	92-16110
	EX [1]	40,26 x 31 x 7,5	G1 45°			A 346 053 06 32	92-16141
	EX [1]	40,46 x 31 x 7,5	G1 45°			A 355 053 12 32 A 355 053 20 32	92-16143

**364**  **128**

OM 345	<b>942</b>								
	01.1966 →	D (NA)	5	9651 cm <sup>3</sup>	4V	141 kW	(192 PS)	17,2:1	150,00 mm
93 568 6..									

	IN [2]	51,06 x 37 x 7,5	G1 45°			A 346 053 07 31 A 355 053 11 31	92-16106
	IN [1]	51,26 x 37 x 7,5	G1 45°			A 346 053 08 31	92-16140
	IN [1]	51,46 x 37 x 7,5	G1 45°			A 355 053 09 31 A 355 053 13 31	92-16142
	EX [2]	40,10 x 31 x 7,5	G1 45°			A 345 053 01 32 A 346 053 05 32 A 355 053 06 32 A 355 053 10 32 A 355 053 18 32	92-16110
	EX [1]	40,46 x 31 x 7,5	G1 45°			A 355 053 12 32 A 355 053 20 32	92-16143

					Reference	Item No.	
<b>365</b>		<b>128</b>	<b>OM 355 910 - 915, 918</b> 1967 → D (NA) 6 11581 cm <sup>3</sup> 4V 169 kW (230 PS) 17,2:1 150,00 mm 93 568 6..				
	IN [2]	42,0 x 9 x 129,8	S - Cr -	- 45° - -	5 - III	A 345 053 71 01 A 346 053 00 01 A 346 053 01 01 A 346 053 03 01	<b>1657</b>
	EX [2]	37,0 x 9 x 165,3	A/S - Cr -	- 45° - -	5 - III	A 345 053 71 05 A 346 053 01 05 A 346 053 02 05 A 355 050 01 27	<b>1658</b>
	IN [6]	15,04 x 9 x 68,5	G1			A 346 053 09 29	<b>81-1640</b>
	IN [4]	15,20 x 9 x 67,5	G1			A 346 053 11 29	<b>81-1642</b>
	EX [6]	15,00 x 9 x 86,5	G1			A 355 053 03 30	<b>81-1641</b>
	IN [2]	51,06 x 37 x 7,5	G1 45°			A 346 053 07 31 A 355 053 11 31	<b>92-16106</b>
	IN [1]	51,46 x 37 x 7,5	G1 45°			A 355 053 09 31 A 355 053 13 31	<b>92-16142</b>
	EX [2]	40,10 x 31 x 7,5	G1 45°			A 345 053 01 32 A 346 053 05 32 A 355 053 06 32 A 355 053 10 32 A 355 053 18 32	<b>92-16110</b>
	EX [1]	40,46 x 31 x 7,5	G1 45°			A 355 053 12 32 A 355 053 20 32	<b>92-16143</b>
		1105 mm				A 355 051 04 01	<b>20 1003 35500</b>
	[12]	M 34 x 70				A 345 054 70 01 A 346 054 02 01 A 355 054 01 01	<b>20 1003 35560</b>
<b>366</b>		<b>128</b>	<b>OM 355 968</b> 09.1967 → D (NA) 6 11581 cm <sup>3</sup> 2V 191 kW (260 PS) 16,5:1 150,00 mm <b>OM 355 969, 977</b> 09.1967 → D (A) 6 11581 cm <sup>3</sup> 4V 205-206 kW (275-280 PS) 16,5:1 150,00 mm 92 582 6..				
	IN [2]	42,0 x 9 x 129,8	S - Cr -	- 45° - -	5 - III	A 345 053 71 01 A 346 053 00 01 A 346 053 01 01 A 346 053 03 01	<b>1657</b>
	IN [6]	15,04 x 9 x 68,5	G1			A 346 053 09 29	<b>81-1640</b>
	IN [4]	15,20 x 9 x 67,5	G1			A 346 053 11 29	<b>81-1642</b>
	EX [6]	15,00 x 9 x 86,5	G1			A 355 053 03 30	<b>81-1641</b>
	IN [1]	51,26 x 37,05 x 7,6	G1 30°			A 355 053 05 31	<b>92-16145</b>
	EX [2]	40,10 x 31 x 7,5	G1			A 355 053 00 32	<b>92-16118</b>
	EX [1]	40,26 x 31 x 7,5	G1			A 355 053 04 32	<b>92-16146</b>
		1105 mm				A 355 051 10 01	<b>20 1003 35501</b>
	[12]	M 34 x 70				A 345 054 70 01 A 346 054 02 01 A 355 054 01 01	<b>20 1003 35560</b>
<b>367</b>		<b>128</b>	<b>OM 355 983 - 984</b> 01.1976 → 02.2001 D (NA) 6 11581 cm <sup>3</sup> 4V 177 kW (240 PS) 17,2:1 150,00 mm 93 568 6..				
Fortsetzung nächste Seite / continued on next page / suite page suivante / continuación página próxima / Продолжение на следующей странице							

					Reference	Item No.
IN [2]	42,0 x 9 x 129,8	S - Cr -	- 45° - -	5 - III	A 345 053 71 01 A 346 053 00 01 A 346 053 01 01 A 346 053 03 01	<b>1657</b>
EX [2]	37,0 x 9 x 165,3	A/S - Cr -	- 45° - -	5 - III	A 345 053 71 05 A 346 053 01 05 A 346 053 02 05 A 355 050 01 27	<b>1658</b>
IN [6]	15,04 x 9 x 68,5	G1			A 346 053 09 29	<b>81-1640</b>
IN [4]	15,20 x 9 x 67,5	G1			A 346 053 11 29	<b>81-1642</b>
EX [6]	15,00 x 9 x 86,5	G1			A 355 053 03 30	<b>81-1641</b>
IN [2]	51,06 x 37 x 7,5	G1 45°			A 346 053 07 31 A 355 053 11 31	<b>92-16106</b>
IN [1]	51,26 x 37 x 7,5	G1 45°			A 346 053 08 31	<b>92-16140</b>
IN [1]	51,46 x 37 x 7,5	G1 45°			A 355 053 09 31 A 355 053 13 31	<b>92-16142</b>
EX [2]	40,10 x 31 x 7,5	G1 45°			A 345 053 01 32 A 346 053 05 32 A 355 053 06 32 A 355 053 10 32 A 355 053 18 32	<b>92-16110</b>
EX [1]	40,26 x 31 x 7,5	G1			A 355 053 04 32	<b>92-16146</b>
EX [1]	40,46 x 31 x 7,5	G1 45°			A 355 053 12 32 A 355 053 20 32	<b>92-16143</b>
	1105 mm				A 355 051 04 01	<b>20 1003 35500</b>
[12]	M 34 x 70				A 345 054 70 01 A 346 054 02 01 A 355 054 01 01	<b>20 1003 35560</b>

M

## 368 128

<b>OM 335</b>	<b>932</b>	D (NA)	6	11581 cm <sup>3</sup>	2V	176 kW	(239 PS)	17,2:1	150,00 mm
<b>OM 335</b>	<b>910, 930</b>	D (NA)	6	11581 cm <sup>3</sup>	4V	154-176 kW	(209-239 PS)	17,2:1	150,00 mm
	09.1969 →								
<b>OM 345</b>	<b>949, 972 - 973, 975</b>	D (NA)	5	9651 cm <sup>3</sup>	4V	143-150 kW	(194-204 PS)	17,2:1	150,00 mm
	03.1986 →								
<b>OM 345</b>	<b>970 (BRA), 974 (BR), 977 - 978 (BRA)</b>	D (A)	5	9651 cm <sup>3</sup>	2V	147-170 kW	(200-230 PS)	16,5:1	150,00 mm
	08.1973 →								
<b>OM 345</b>	<b>950 (BRA), 952 - 953 (BRA)</b>	D (LA)	6	11581 cm <sup>3</sup>	2V	235-250 kW	(320-340 PS)	16,5:1	150,00 mm
<b>OM 347</b>	<b>917, 970 - 971</b>	D (A)	5	9651 cm <sup>3</sup>	4V	170-175 kW	(230-238 PS)		150,00 mm

93 568 6..

IN [2]	51,06 x 37 x 7,5	G1 45°				A 346 053 07 31 A 355 053 11 31	<b>92-16106</b>
IN [1]	51,46 x 37 x 7,5	G1 45°				A 355 053 09 31 A 355 053 13 31	<b>92-16142</b>
EX [2]	40,10 x 31 x 7,5	G1 45°				A 345 053 01 32 A 346 053 05 32 A 355 053 06 32 A 355 053 10 32 A 355 053 18 32	<b>92-16110</b>
EX [1]	40,26 x 31 x 7,5	G1 45°				A 346 053 06 32	<b>92-16141</b>
EX [1]	40,46 x 31 x 7,5	G1 45°				A 355 053 12 32 A 355 053 20 32	<b>92-16143</b>

					Reference	Item No.
<b>369</b>		<b>128</b>				
<b>OM 421</b>	<b>900/-000</b> 1979 →	D	6	10965 cm <sup>3</sup>	2V	142,00 mm
<b>OM 421</b>	<b>906, 910</b> 01.1970 →	D (NA)	6	10964 cm <sup>3</sup>	2V 159 kW (216 PS) 16,9:1	142,00 mm
<b>OM 423</b>	<b>900/-000</b> 01.1983 → 06.1987	D	10	18273 cm <sup>3</sup>	2V	142,00 mm
<b>OM 424</b>	<b>900</b> 01.1984 → 08.1987	D (NA)	12	21927 cm <sup>3</sup>	2V 309 kW (420 PS)	142,00 mm
93 484 6..., 93 484 7..						
	IN [1]	59,0 x 12 x 142,5	A/S - Cr -	- 30° -	- 5 - III	A 403 053 09 01 A 422 050 00 26 A 422 050 02 26 A 422 050 05 26 A 422 053 01 01 A 423 050 00 26 A 442 050 02 26 A 442 050 03 26 <b>16117</b>
	IN [1]	59,0 x 12 x 142,5	A/S - Cr -	- 30° -	- 5 - III	A 442 050 05 26 <b>16146</b>
	IN [1]	59,0 x 12 x 142,5	S - Cr -	- 30° - VS -	- 5 - III	A 423 050 00 26 <b>1606</b>
	EX [1]	51,0 x 12 x 142,5	A/S - Cr -	- 45° -	- 5 - III	A 422 050 00 27 <b>16116</b>
	EX [1]	51,0 x 12 x 142,5	RA/S- Cr -	- 45° -	- 5 - III	A 422 050 01 27 A 422 050 02 27 A 442 050 01 27 A 442 050 02 27 A 442 050 03 27 A 442 050 04 27 <b>16150</b>
	EX [1]	51,1 x 12 x 142,5	A/S - Cr -	- 45° -	- 5 - III	A 423 050 04 27 <b>1608</b>
	[50]					A 000 053 04 26 <b>LK-1605</b>
	[50]	∅ 12 mm				A 422 053 00 26 <b>LK-1610</b>
	IN/EX [6]	18,03 x 12 x 67,0	G2			A 422 053 04 30 <b>81-16100</b>
	IN [2]	60,11 x 51 x 8,9	G1 30°			A 403 053 09 31 A 403 053 15 31 <b>92-16100</b>
	IN [1]	60,31 x 51 x 9,1	G1 30°			A 403 053 10 31 <b>92-16147</b>
	IN [1]	60,51 x 51 x 9,3	G1 30°			A 403 053 11 31 <b>92-16101</b>
	EX [2]	53,11 x 43 x 9,7	G1 45°			A 403 053 00 32 A 403 053 03 32 A 403 053 21 32 A 403 053 25 32 A 403 053 28 32 A 403 053 01 32 A 403 053 13 32 A 403 053 22 32 A 403 053 26 32 A 403 053 29 32 A 403 053 02 32 A 403 053 23 32 A 403 053 27 32 A 403 053 30 32 <b>92-16104</b>
	EX [1]	53,31 x 43 x 9,9	G1 45°			<b>92-16148</b>
	EX [1]	53,51 x 43 x 10,2	G1 45°			<b>92-16105</b>
	[12]	M 32 x 76 x 20				A 422 050 03 25 A 476 050 00 25 <b>20 1003 44000 (1)</b>
	[12]	M 32 x 76 x 20				A 422 050 03 25 A 476 050 00 25 <b>20 1003 44001 NEW (2)</b>
	(1)	OES specification				
	(2)	IAM specification				
Fortsetzung nächste Seite / continued on next page / suite page suivante / continuación página próxima / Продолжение на следующей странице						



					Reference	Item No.
[4]					A 403 050 07 33	20 1002 25010 (3)
[1]					A 442 050 03 33	
[1]					A 403 050 03 33	20 1003 40010
					A 403 050 07 33	
					A 442 050 03 33	20 1003 40012 (4)
					A 403 050 03 33	
					A 403 050 07 33	
					A 442 050 03 33	
					A 442 055 00 20	
(3)					nur 2-Ventiler/only 2 valves version/seulement 2 soupapes/sólo sistemas de 2 válvulas/заменяемо 2 Клапаны	
(4)					mit Einstellschraube/with adjusting screw/avec vis de réglage/con tornillo de ajuste/c установочным винтом	
	- - G - S -	- - - -			A 402 010 03 20	20 0803 40300
					A 403 010 40 20	
					A 403 010 89 20	
					A 427 010 00 20	
					A 427 010 10 20	
					A 429 010 02 20	
					A 442 010 07 20	
	- V - G - S -	- - - -	ready-to-install		A 427 010 10 20	20 0803 40301

## 370 128

OM 422

905 - 923

01.1970 →

D (NA) 8 14618 cm<sup>3</sup> 2V 184-206 kW (250-280 PS) 16,9:1 142,00 mm

93 484 6.., 93 484 7..

IN [1]	59,0 x 12 x 142,5	A/S - Cr -	- 30° - -	5 - III	A 403 053 09 01	16117
					A 422 050 00 26	
					A 422 050 02 26	
					A 422 050 05 26	
					A 422 053 01 01	
					A 423 050 00 26	
					A 442 050 02 26	
					A 442 050 03 26	
					A 442 050 05 26	
					A 423 050 00 26	
IN [1]	59,0 x 12 x 142,5	A/S - Cr -	- 30° - -	5 - III	A 442 050 05 26	16146
IN [1]	59,0 x 12 x 142,5	S - Cr -	- 30° - VS -	5 - III	A 423 050 00 26	1606
EX [1]	51,0 x 12 x 142,5	A/S - Cr -	- 45° - -	5 - III	A 422 050 00 27	16116
EX [1]	51,0 x 12 x 142,5	RA/S- Cr -	- 45° - -	5 - III	A 422 050 01 27	16150
					A 422 050 02 27	
					A 442 050 01 27	
					A 442 050 02 27	
					A 442 050 03 27	
					A 442 050 04 27	
EX [1]	51,1 x 12 x 142,5	A/S - Cr -	- 45° - -	5 - III	A 423 050 04 27	1608
[50]					A 000 053 04 26	LK-1605
[50]	Ø 12 mm				A 422 053 00 26	LK-1610

Fortsetzung nächste Seite / continued on next page / suite page suivante / continuación página próxima / Продолжение на следующей странице

					Reference	Item No.	
	IN/EX [6]	18,03 x 12 x 67,0	G1		A 403 053 00 30	<b>81-1647</b>	
	IN/EX [6]	18,03 x 12 x 67,0	G2		A 422 053 04 30	<b>81-16100</b>	
	IN/EX [6]	18,23 x 12 x 67,0	G1		A 403 053 01 30	<b>81-1648</b>	
	IN [2]	60,11 x 51 x 8,9	G1 30°		A 403 053 09 31 A 403 053 15 31	<b>92-16100</b>	
	IN [1]	60,31 x 51 x 9,1	G1 30°		A 403 053 10 31	<b>92-16147</b>	
	IN [1]	60,51 x 51 x 9,3	G1 30°		A 403 053 11 31	<b>92-16101</b>	
	EX [2]	53,11 x 43 x 9,7	G1 45°		A 403 053 00 32 A 403 053 03 32 A 403 053 21 32 A 403 053 25 32 A 403 053 28 32	<b>92-16104</b>	
	EX [1]	53,31 x 43 x 9,9	G1 45°		A 403 053 01 32 A 403 053 13 32 A 403 053 22 32 A 403 053 26 32 A 403 053 29 32	<b>92-16148</b>	
	EX [1]	53,51 x 43 x 10,2	G1 45°		A 403 053 02 32 A 403 053 23 32 A 403 053 27 32 A 403 053 30 32	<b>92-16105</b>	
		724 mm			A 422 050 01 01 A 422 050 03 01 A 422 050 05 01 A 422 050 21 01	<b>20 1003 42200</b>	
		[12]	M 31,5 x 76,5 x 20			A 403 054 09 01 A 403 054 18 01	<b>20 1003 40060</b>
		[12]	M 32 x 76 x 20			A 422 050 03 25 A 476 050 00 25	<b>20 1003 44000</b> (1)
		[12]	M 32 x 76 x 20			A 422 050 03 25 A 476 050 00 25	<b>20 1003 44001</b> <b>NEW</b> (2)
	(1)	OES specification					
	(2)	IAM specification					
	[4]				A 403 050 07 33 A 442 050 03 33	<b>20 1002 25010</b> (3)	
	[1]				A 403 050 03 33 A 403 050 07 33 A 442 050 03 33	<b>20 1003 40010</b>	
	[1]				A 403 050 03 33 A 403 050 07 33 A 442 050 03 33 A 442 055 00 20	<b>20 1003 40012</b> (4)	
	(3)	nur 2-Ventiler/only 2 valves version/seulement 2 soupapes/sólo sistemas de 2 válvulas/заменяемо 2 Клапаны					
(4)	mit Einstellschraube/with adjusting screw/avec vis de réglage/con tornillo de ajuste/c установочным ВИНТОМ						
Fortsetzung nächste Seite / continued on next page / suite page suivante / continuación página próxima / Продолжение на следующей странице							

					Reference	Item No.
	- - G - S -	- - -			A 402 010 03 20 A 403 010 40 20 A 403 010 89 20 A 427 010 00 20 A 427 010 10 20 A 429 010 02 20 A 442 010 07 20	<b>20 0803 40300</b>
	- V - G - S -	- - -	ready-to-install		A 427 010 10 20	<b>20 0803 40301</b>

## 371 128

<b>OM 440 Euro 1</b>	<b>945</b>									
	01.1970 →	D (A)	8	14618 cm <sup>3</sup>	2V	250 kW	(340 PS)	18:1	142,00 mm	
<b>OM 442 Euro 1</b>	<b>995 - 996</b>									
	01.1991 →	D (LA)	8	14618 cm <sup>3</sup>	2V	320-370 kW	(435-503 PS)	16,75:1	142,00 mm	

94 331 7..

	IN [1]	59,0 x 12 x 142,5	A/S - Cr -	- 30° -	-	5 - III	A 403 053 09 01 A 422 050 00 26 A 422 050 02 26 A 422 050 05 26 A 422 053 01 01 A 423 050 00 26 A 442 050 02 26 A 442 050 03 26	<b>16117</b>
	IN [1]	59,0 x 12 x 142,5	A/S - Cr -	- 30° -	-	5 - III	A 442 050 05 26	<b>16146</b>
	EX [1]	51,0 x 12 x 142,5	RA/S- Cr -	- 45° -	-	5 - III	A 422 050 01 27 A 422 050 02 27 A 442 050 01 27 A 442 050 02 27 A 442 050 03 27 A 442 050 04 27	<b>16150</b>
	[50]	∅ 12 mm					A 422 053 00 26	<b>LK-1610</b>
	IN/EX [6]	18,03 x 12 x 67,0	G2				A 422 053 04 30	<b>81-16100</b>
	IN [2]	60,11 x 51.2 x 8,4	G1 30°				A 422 053 05 31	<b>92-16151</b>
	IN [1]	60,31 x 51.2 x 8,6	G1 30°				A 422 053 06 31	<b>92-16152</b>
	EX [2]	53,11 x 43 x 9,2	G1 45°				A 442 053 00 32	<b>92-16127</b>
	EX [1]	53,11 x 43 x 9,2	G1 45°				A 422 053 01 32	<b>92-16126</b>
	EX [1]	53,31 x 43 x 9,4	G1 45°				A 442 053 01 32	<b>92-16149</b>
	EX [1]	53,51 x 43.2 x 9,6	G1 45°				A 442 053 02 32	<b>92-16128</b>
		724 mm					A 402 050 21 01 A 402 050 25 01 A 442 050 17 01	<b>20 1003 40201</b>

Fortsetzung nächste Seite / continued on next page / suite page suivante / continuación página próxima / Продолжение на следующей странице

					Reference	Item No.
	[12] M 31,5 x 76,5 x 20				A 403 054 09 01 A 403 054 18 01	<b>20 1003 40060</b>
	[12] M 32 x 76 x 20				A 422 050 03 25 A 476 050 00 25	<b>20 1003 44000</b> (1)
	[12] M 32 x 76 x 20				A 422 050 03 25 A 476 050 00 25	<b>20 1003 44001</b> <b>NEW</b> (2)
	(1) OES specification (2) IAM specification					
	[4]				A 403 050 07 33 A 442 050 03 33	<b>20 1002 25010</b> (3)
	[1]				A 403 050 03 33 A 403 050 07 33 A 442 050 03 33	<b>20 1003 40010</b>
	[1]				A 403 050 03 33 A 403 050 07 33 A 442 050 03 33 A 442 055 00 20	<b>20 1003 40012</b> (4)
	(3) nur 2-Ventiler/only 2 valves version/seulement 2 soupapes/sólo sistemas de 2 válvulas/заменяемо 2 Клапаны					
	(4) mit Einstellschraube/with adjusting screw/avec vis de réglage/con tornillo de ajuste/c установочным ВИНТОМ					
	- - G - S -	- - - -			A 402 010 03 20 A 403 010 40 20 A 403 010 89 20 A 427 010 00 20 A 427 010 10 20 A 429 010 02 20 A 442 010 07 20	<b>20 0803 40300</b>
	- V - G - S -	- - - -	ready-to-install		A 427 010 10 20	<b>20 0803 40301</b>

## 372 128

<b>OM 442 Euro 1</b>	<b>999</b>								
	07.1995 →	D (LA)	8	14618 cm <sup>3</sup>	2V	370 kW	(503 PS)	16,75:1	142,00 mm
<b>OM 445 Euro 2</b>	<b>934 - 935</b>								
	01.1970 →	D (A)	6	10964 cm <sup>3</sup>	2V	213-250 kW	(290-340 PS)	17,25:1	142,00 mm
<b>OM 445 Euro 2</b>	<b>920 - 922, 924 - 927, 929 - 931, 933, 936 - 941</b>								
	01.1992 →	D (LA)	6	10964 cm <sup>3</sup>	2V	180-250 kW	(245-340 PS)	17,25:1	142,00 mm
<b>OM 446 Euro 2</b>	<b>932 - 933</b>								
	01.1994 →	D (LA)	8	14618 cm <sup>3</sup>	2V	390 kW	(530 PS)	17,25:1	142,00 mm

94 331 7..., 94 681 6..

Fortsetzung nächste Seite / continued on next page / suite page suivante / continuación página próxima / Продолжение на следующей странице

					Reference	Item No.
	IN [1] 59,0 x 12 x 142,5	A/S - Cr -	- 30° - -	5 - III	A 403 053 09 01 A 422 050 00 26 A 422 050 02 26 A 422 050 05 26 A 422 053 01 01 A 423 050 00 26 A 442 050 02 26 A 442 050 03 26	<b>16117</b>
	IN [1] EX [2] 17,1 x 8 x 90,3	A/S - Cr - A - -	- 30° - - - 45° - -	5 - III 1 -	A 442 050 05 26 A 442 016 02 91 A 442 016 03 91	<b>16146</b> <b>50 004 665</b> (1)
	EX [1] 51,0 x 12 x 142,5	RA/S- Cr -	- 45° - -	5 - III	A 422 050 01 27 A 422 050 02 27 A 442 050 01 27 A 442 050 02 27 A 442 050 03 27 A 442 050 04 27	<b>16150</b>
	(1) Konstantdrosselventil - Dom Exhaust brake valve - dome Papillon constant - Dôme Válvula de estrangulamiento constante - Dom Нерегулируемый дроссельный клапан - собор					
	[50] Ø 12 mm				A 422 053 00 26	<b>LK-1610</b>
	IN/EX [6] 18,03 x 12 x 67,0	G2			A 422 053 04 30	<b>81-16100</b>
	IN [2] 60,11 x 51.2 x 8,4	G1 45°			A 442 053 05 31	<b>92-16122</b>
	IN [1] 60,51 x 51.2 x 8,9	G1 30°			A 442 053 07 31	<b>92-16123</b>
	EX [2] 53,11 x 43 x 9,2	G1 45°			A 442 053 00 32	<b>92-16127</b>
	EX [1] 53,11 x 43 x 9,2	G1 45°			A 422 053 01 32	<b>92-16126</b>
	EX [1] 53,31 x 43 x 9,4	G1 45°			A 442 053 01 32	<b>92-16149</b>
	EX [1] 53,51 x 43.2 x 9,6	G1 45°			A 442 053 02 32	<b>92-16128</b>
	[12] M 31,5 x 76,5 x 20				A 403 054 09 01 A 403 054 18 01	<b>20 1003 40060</b>
	[12] M 32 x 76 x 20				A 422 050 03 25 A 476 050 00 25	<b>20 1003 44000</b> (2)
	[12] M 32 x 76 x 20				A 422 050 03 25 A 476 050 00 25	<b>20 1003 44001</b> <span style="border: 1px solid black; padding: 1px;">NEW</span> (3)
	(2) OES specification (3) IAM specification					
	[4]				A 403 050 07 33 A 442 050 03 33	<b>20 1002 25010</b> (4)
	[1]				A 403 050 03 33 A 403 050 07 33 A 442 050 03 33	<b>20 1003 40010</b>
	[1]				A 403 050 03 33 A 403 050 07 33 A 442 050 03 33 A 442 055 00 20	<b>20 1003 40012</b> (5)
	(4) nur 2-Ventiler/only 2 valves version/seulement 2 soupapes/sólo sistemas de 2 válvulas/заменяемо 2 Клапаны					
	(5) mit Einstellschraube/with adjusting screw/avec vis de réglage/con tornillo de ajuste/c установочным винтом					
Fortsetzung nächste Seite / continued on next page / suite page suivante / continuación página próxima / Продолжение на следующей странице						

M



					Reference	Item No.
	- V - G - S -	- - - EVB	ready-to-install		A 442 010 06 20	<b>20 0803 44000</b>
		- - G - S -			A 442 010 06 20	<b>20 0803 44010</b>

## 373 128

<b>OM 421</b>	<b>908 - 909</b>	04.1973 → 10.1990	D (NA)	6	10964 cm <sup>3</sup>	2V	159 kW	(216 PS)	16,9:1	142,00 mm
<b>OM 427</b>	<b>900/-000, 901/-200</b>		D	6	11970 cm <sup>3</sup>	2V				155,00 mm

93 484 6.., 93 484 7..

	IN [1]	59,0 x 12 x 142,5	A/S - Cr -	- 30° -	-	5 - III	A 403 053 09 01 A 422 050 00 26 A 422 050 02 26 A 422 050 05 26 A 422 053 01 01 A 423 050 00 26 A 442 050 02 26 A 442 050 03 26	<b>16117</b>
	IN [1]	59,0 x 12 x 142,5	A/S - Cr -	- 30° -	-	5 - III	A 442 050 05 26	<b>16146</b>
	IN [1]	59,0 x 12 x 142,5	S - Cr -	- 30° -	VS -	5 - III	A 423 050 00 26	<b>1606</b>
	EX [1]	51,0 x 12 x 142,5	A/S - Cr -	- 45° -	-	5 - III	A 422 050 00 27	<b>16116</b>
	EX [1]	51,0 x 12 x 142,5	RA/S- Cr -	- 45° -	-	5 - III	A 422 050 01 27 A 422 050 02 27 A 442 050 01 27 A 442 050 02 27 A 442 050 03 27 A 442 050 04 27	<b>16150</b>
	EX [1]	51,1 x 12 x 142,5	A/S - Cr -	- 45° -	-	5 - III	A 423 050 04 27	<b>1608</b>
	[50]						A 000 053 04 26	<b>LK-1605</b>
	[50]	Ø 12 mm					A 422 053 00 26	<b>LK-1610</b>
	IN/EX [6]	18,03 x 12 x 67,0	G1				A 403 053 00 30	<b>81-1647</b>
	IN/EX [6]	18,03 x 12 x 67,0	G2				A 422 053 04 30	<b>81-16100</b>
	IN/EX [6]	18,23 x 12 x 67,0	G1				A 403 053 01 30	<b>81-1648</b>

Fortsetzung nächste Seite / continued on next page / suite page suivante / continuación página próxima / Продолжение на следующей странице

					Reference	Item No.
	IN [2] 60,11 x 51 x 8,9	G1 30°			A 403 053 09 31 A 403 053 15 31	<b>92-16100</b>
	IN [1] 60,31 x 51 x 9,1	G1 30°			A 403 053 10 31	<b>92-16147</b>
	IN [1] 60,51 x 51 x 9,3	G1 30°			A 403 053 11 31	<b>92-16101</b>
	EX [2] 53,11 x 43 x 9,7	G1 45°			A 403 053 00 32 A 403 053 03 32 A 403 053 21 32 A 403 053 25 32 A 403 053 28 32	<b>92-16104</b>
	EX [1] 53,31 x 43 x 9,9	G1 45°			A 403 053 01 32 A 403 053 13 32 A 403 053 22 32 A 403 053 26 32 A 403 053 29 32	<b>92-16148</b>
	EX [1] 53,51 x 43 x 10,2	G1 45°			A 403 053 02 32 A 403 053 23 32 A 403 053 27 32 A 403 053 30 32	<b>92-16105</b>
	[12] M 32 x 76 x 20				A 422 050 03 25 A 476 050 00 25	<b>20 1003 44000</b> (1)
	[12] M 32 x 76 x 20				A 422 050 03 25 A 476 050 00 25	<b>20 1003 44001</b> <small>NEW</small> (2)
	(1) OES specification (2) IAM specification					
	[4]				A 403 050 07 33 A 442 050 03 33	<b>20 1002 25010</b> (3)
	[1]				A 403 050 03 33 A 403 050 07 33 A 442 050 03 33	<b>20 1003 40010</b>
	[1]				A 403 050 03 33 A 403 050 07 33 A 442 050 03 33 A 442 055 00 20	<b>20 1003 40012</b> (4)
	(3) nur 2-Ventiler/only 2 valves version/seulement 2 soupapes/sólo sistemas de 2 válvulas/заменяемо 2 Клапаны					
	(4) mit Einstellschraube/with adjusting screw/avec vis de réglage/con tornillo de ajuste/c установочным винтом					
	- - G - S -	- - -			A 402 010 03 20 A 403 010 40 20 A 403 010 89 20 A 427 010 00 20 A 427 010 10 20 A 429 010 02 20 A 442 010 07 20	<b>20 0803 40300</b>
	- V - G - S -	- - -	ready-to-install		A 427 010 10 20	<b>20 0803 40301</b>

M

					Reference	Item No.
<b>374</b>		<b>128</b>				
<b>OM 462 Euro 0</b>	<b>900-410 (AFS)</b>	12.1991 → 09.1996	D (A)	8	14618 cm <sup>3</sup> 2V	260 kW (354 PS) 16,25 142,00 mm
<b>OM 462 Euro 0</b>	<b>900-510 (AFS)</b>	08.1973 → 09.1996	D (LA)	8	14618 cm <sup>3</sup> 2V	320 kW (435 PS) 16,25 142,00 mm
<b>OM 466</b>	<b>900-405</b>	01.1996 →	D (A)	6	11970 cm <sup>3</sup> 2V	175 kW (238 PS) 16,25 155,00 mm
90 220 6.., 91 630 6..						
	IN [1]	59,0 x 12 x 142,5	A/S - Cr -	- 30° -	- 5 - III	A 403 053 09 01 A 422 050 00 26 A 422 050 02 26 A 422 050 05 26 A 422 053 01 01 A 423 050 00 26 A 442 050 02 26 A 442 050 03 26 <b>16117</b>
	IN [1]	59,0 x 12 x 142,5	A/S - Cr -	- 30° -	- 5 - III	A 442 050 05 26 <b>16146</b>
	EX [1]	51,0 x 12 x 142,5	RA/S- Cr -	- 45° -	- 5 - III	A 422 050 01 27 A 422 050 02 27 A 442 050 01 27 A 442 050 02 27 A 442 050 03 27 A 442 050 04 27 <b>16150</b>
	[50]	∅ 12 mm				A 422 053 00 26 <b>LK-1610</b>
	IN/EX [6]	18,03 x 12 x 67,0	G2			A 422 053 04 30 <b>81-16100</b>
	IN [2]	60,11 x 51.2 x 8,4	G1 30°			A 422 053 05 31 <b>92-16151</b>
	IN [1]	60,31 x 51.2 x 8,6	G1 30°			A 422 053 06 31 <b>92-16152</b>
	EX [2]	53,11 x 43 x 9,2	G1 45°			A 442 053 00 32 <b>92-16127</b>
	EX [1]	53,11 x 43 x 9,2	G1 45°			A 422 053 01 32 <b>92-16126</b>
	EX [1]	53,31 x 43 x 9,4	G1 45°			A 442 053 01 32 <b>92-16149</b>
	EX [1]	53,51 x 43.2 x 9,6	G1 45°			A 442 053 02 32 <b>92-16128</b>
	[1]					A 403 050 03 33 A 403 050 07 33 A 442 050 03 33 <b>20 1003 40010</b>
	[1]					A 403 050 03 33 A 403 050 07 33 A 442 050 03 33 A 442 055 00 20 <b>20 1003 40012 (1)</b>
	(1) mit Einstellschraube/with adjusting screw/avec vis de réglage/con tornillo de ajuste/c установочным винтом					

## 375 128

**OM 492** **900-001 (AFS), 900-002 (AFS), 900-004 (AFS), 900-005, 900-007, 900-008, 900-009**  
08.1973 → D 8 14618 cm<sup>3</sup> 2V 184-206 kW (250-280 PS) 16,9:1 142,00 mm

93 484 6.., 93 484 7..

Fortsetzung nächste Seite / continued on next page / suite page suivante / continuación página próxima / Продолжение на следующей странице

					Reference	Item No.
	IN [1] 59,0 x 12 x 142,5	A/S - Cr -	- 30° - -	5 - III	A 403 053 09 01 A 422 050 00 26 A 422 050 02 26 A 422 050 05 26 A 422 053 01 01 A 423 050 00 26 A 442 050 02 26 A 442 050 03 26	<b>16117</b>
	IN [1] EX [1] 59,0 x 12 x 142,5 51,0 x 12 x 142,5	A/S - Cr - RA/S- Cr -	- 30° - - - 45° - -	5 - III 5 - III	A 442 050 05 26 A 422 050 01 27 A 422 050 02 27 A 442 050 01 27 A 442 050 02 27 A 442 050 03 27 A 442 050 04 27	<b>16146</b> <b>16150</b>
	[50] Ø 12 mm				A 422 053 00 26	<b>LK-1610</b>
	IN/EX [6] IN/EX [6] IN/EX [6] 18,03 x 12 x 67,0 18,03 x 12 x 67,0 18,23 x 12 x 67,0	G1 G2 G1			A 403 053 00 30 A 422 053 04 30 A 403 053 01 30	<b>81-1647</b> <b>81-16100</b> <b>81-1648</b>
	IN [2] IN [1] IN [1] IN [1] EX [2] EX [2] 53,11 x 43 x 9,2 53,11 x 43 x 9,7	G1 30° G1 30° G1 30° G1 30° G1 45° G1 45°			A 403 053 09 31 A 403 053 15 31 A 422 053 01 31 A 447 053 00 31 A 403 053 10 31 A 403 053 11 31 A 442 053 00 32 A 403 053 00 32 A 403 053 03 32 A 403 053 21 32 A 403 053 25 32 A 403 053 28 32	<b>92-16100</b> <b>92-16150</b> <b>92-16147</b> <b>92-16101</b> <b>92-16127</b> <b>92-16104</b>
	EX [1] EX [1] EX [1] 53,11 x 43 x 9,2 53,31 x 43 x 9,4 53,31 x 43 x 9,9	G1 45° G1 45° G1 45°			A 422 053 01 32 A 442 053 01 32 A 403 053 01 32 A 403 053 13 32 A 403 053 22 32 A 403 053 26 32 A 403 053 29 32	<b>92-16126</b> <b>92-16149</b> <b>92-16148</b>
	EX [1] 53,51 x 43 x 10,2	G1 45°			A 403 053 02 32 A 403 053 23 32 A 403 053 27 32 A 403 053 30 32	<b>92-16105</b>
	EX [1] 53,51 x 43.2 x 9,6	G1 45°			A 442 053 02 32	<b>92-16128</b>
	724 mm				A 422 050 01 01 A 422 050 03 01 A 422 050 05 01 A 422 050 21 01	<b>20 1003 42200</b>
	[1] [1]				A 403 050 03 33 A 403 050 07 33 A 442 050 03 33 A 403 050 03 33 A 403 050 07 33 A 442 050 03 33 A 442 055 00 20	<b>20 1003 40010</b> <b>20 1003 40012 (1)</b>
	(1) mit Einstellschraube/with adjusting screw/avec vis de réglage/con tornillo de ajuste/c установочным винтом					

M

					Reference	Item No.
--	--	--	--	--	-----------	----------

## 376 128

<b>OM 345</b>	<b>910, 912, 932 - 933, 936 - 937</b>	D (NA)	6	11581 cm <sup>3</sup>	4V	137-177 kW	(186-241 PS)	17,2:1	150,00 mm
<b>OM 355</b>	<b>976-001 (AFS), 976-002 (AFS), 976-003 (AFS), 976-004 (AFS), 976-007 (AFS)</b>	D	6	11581 cm <sup>3</sup>	4V	177 kW	(240 PS)	17,2:1	150,00 mm

93 568 6..

	IN [2]	42,0 x 9 x 129,8	S - Cr -	- 45° -	-	5 - III	A 345 053 71 01 A 346 053 00 01 A 346 053 01 01 A 346 053 03 01	<b>1657</b>
	EX [2]	37,0 x 9 x 165,3	A/S - Cr -	- 45° -	-	5 - III	A 345 053 71 05 A 346 053 01 05 A 346 053 02 05 A 355 050 01 27	<b>1658</b>
	IN [6]	15,04 x 9 x 68,5	G1				A 346 053 09 29	<b>81-1640</b>
	IN [4]	15,20 x 9 x 67,5	G1				A 346 053 11 29	<b>81-1642</b>
	EX [6]	15,00 x 9 x 86,5	G1				A 355 053 03 30	<b>81-1641</b>
	IN [2]	51,06 x 37 x 7,5	G1 45°				A 346 053 07 31 A 355 053 11 31	<b>92-16106</b>
	IN [1]	51,26 x 37 x 7,5	G1 45°				A 346 053 08 31	<b>92-16140</b>
	IN [1]	51,46 x 37 x 7,5	G1 45°				A 355 053 09 31 A 355 053 13 31	<b>92-16142</b>
	EX [2]	40,10 x 31 x 7,5	G1 45°				A 345 053 01 32 A 346 053 05 32 A 355 053 06 32 A 355 053 10 32 A 355 053 18 32	<b>92-16110</b>
	EX [1]	40,26 x 31 x 7,5	G1 45°				A 346 053 06 32	<b>92-16141</b>
	EX [1]	40,46 x 31 x 7,5	G1 45°				A 355 053 12 32 A 355 053 20 32	<b>92-16143</b>
		1105 mm					A 355 051 04 01	<b>20 1003 35500</b>

## 377 128

<b>OM 345</b>	<b>913, 960</b>	D (A)	6	11581 cm <sup>3</sup>	4V	210 kW	(286 PS)	16,5:1	150,00 mm
---------------	-----------------	-------	---	-----------------------	----	--------	----------	--------	-----------

92 582 6..

	IN [1]	51,26 x 37,05 x 7,6	G1 30°				A 355 053 05 31	<b>92-16145</b>
	EX [2]	40,10 x 31 x 7,5	G1				A 355 053 00 32	<b>92-16118</b>
	EX [1]	40,26 x 31 x 7,5	G1				A 355 053 04 32	<b>92-16146</b>
		1105 mm					A 355 051 10 01	<b>20 1003 35501</b>

## 378 128

<b>OM 422</b>	<b>901-500</b>	D (LA)	8	14618 cm <sup>3</sup>	2V				142,00 mm
<b>OM 422</b>	<b>901-410</b>	D (A)	8	14618 cm <sup>3</sup>	2V	206 kW	(280 PS)	16,9:1	142,00 mm

93 484 6.., 93 484 7.., 93 485 6..

Fortsetzung nächste Seite / continued on next page / suite page suivante / continuación página próxima / Продолжение на следующей странице



					Reference	Item No.
	IN [1] 59,0 x 12 x 142,5	A/S - Cr -	- 30° - -	5 - III	A 403 053 09 01 A 422 050 00 26 A 422 050 02 26 A 422 050 05 26 A 422 053 01 01 A 423 050 00 26 A 442 050 02 26 A 442 050 03 26	<b>16117</b>
	IN [1] 59,0 x 12 x 142,5	A/S - Cr -	- 30° - -	5 - III	A 442 050 05 26	<b>16146</b>
	IN [1] 59,0 x 12 x 142,5	S - Cr -	- 30° - VS -	5 - III	A 423 050 00 26	<b>1606</b>
	EX [1] 51,0 x 12 x 142,5	A/S - Cr -	- 45° - -	5 - III	A 422 050 00 27	<b>16116</b>
	EX [1] 51,0 x 12 x 142,5	RA/S- Cr -	- 45° - -	5 - III	A 422 050 01 27 A 422 050 02 27 A 442 050 01 27 A 442 050 02 27 A 442 050 03 27 A 442 050 04 27	<b>16150</b>
	EX [1] 51,1 x 12 x 142,5	A/S - Cr -	- 45° - -	5 - III	A 423 050 04 27	<b>1608</b>
	[50] [50] Ø 12 mm				A 000 053 04 26 A 422 053 00 26	<b>LK-1605</b> <b>LK-1610</b>
	IN/EX [6] IN/EX [6] IN/EX [6] 18,03 x 12 x 67,0 18,03 x 12 x 67,0 18,23 x 12 x 67,0	G1 G2 G1			A 403 053 00 30 A 422 053 04 30 A 403 053 01 30	<b>81-1647</b> <b>81-16100</b> <b>81-1648</b>
	IN [2] IN [2] IN [1] IN [1] IN [1] EX [2] EX [2] 60,11 x 51 x 8,9 60,11 x 51.2 x 8,4 60,31 x 51 x 9,1 60,31 x 51.2 x 8,6 60,51 x 51 x 9,3 53,11 x 43 x 9,2 53,11 x 43 x 9,7	G1 30° G1 30° G1 30° G1 30° G1 30° G1 45° G1 45°			A 403 053 09 31 A 403 053 15 31 A 422 053 05 31 A 403 053 10 31 A 422 053 06 31 A 403 053 11 31 A 442 053 00 32 A 403 053 00 32 A 403 053 03 32 A 403 053 21 32 A 403 053 25 32 A 403 053 28 32	<b>92-16100</b> <b>92-16151</b> <b>92-16147</b> <b>92-16152</b> <b>92-16101</b> <b>92-16127</b> <b>92-16104</b>
	EX [1] EX [1] EX [1] 53,11 x 43 x 9,2 53,31 x 43 x 9,4 53,31 x 43 x 9,9	G1 45° G1 45° G1 45°			A 422 053 01 32 A 442 053 01 32 A 403 053 01 32 A 403 053 13 32 A 403 053 22 32 A 403 053 26 32 A 403 053 29 32	<b>92-16126</b> <b>92-16149</b> <b>92-16148</b>
	EX [1] 53,51 x 43 x 10,2	G1 45°			A 403 053 02 32 A 403 053 23 32 A 403 053 27 32 A 403 053 30 32	<b>92-16105</b>
	EX [1] 53,51 x 43.2 x 9,6	G1 45°			A 442 053 02 32	<b>92-16128</b>
	724 mm				A 422 050 00 01 A 422 050 04 01 A 422 050 10 01 A 422 050 22 01	<b>20 1003 42201</b>
	[12] [12] M 32 x 76 x 20 M 32 x 76 x 20				A 422 050 03 25 A 476 050 00 25 A 422 050 03 25 A 476 050 00 25	<b>20 1003 44000</b> (1) <b>20 1003 44001</b> <b>NEW</b> (2)
	(1) OES specification (2) IAM specification					
Fortsetzung nächste Seite / continued on next page / suite page suivante / continuación página próxima / Продолжение на следующей странице						

**M**

					Reference	Item No.	
[4]					A 403 050 07 33	<b>20 1002 25010</b> (3)	
[1]					A 442 050 03 33		
[1]					A 403 050 03 33	<b>20 1003 40010</b>	
					A 403 050 07 33		
					A 442 050 03 33	<b>20 1003 40012</b> (4)	
					A 403 050 03 33		
					A 403 050 07 33		
					A 442 050 03 33		
					A 442 055 00 20		
(3)	nur 2-Ventiler/only 2 valves version/seulement 2 soupapes/sólo sistemas de 2 válvulas/заменяемо 2 Клапаны						
(4)	mit Einstellschraube/with adjusting screw/avec vis de réglage/con tornillo de ajuste/c установочным ВИНТОМ						
	- - G - S -	- - - -			A 402 010 03 20	<b>20 0803 40300</b>	
					A 403 010 40 20		
					A 403 010 89 20		
					A 427 010 00 20		
					A 427 010 10 20		
					A 429 010 02 20		
					A 442 010 07 20		
	- V - G - S -	- - - -	ready-to-install		A 427 010 10 20	<b>20 0803 40301</b>	

## 379 128

<b>OM 421</b>	<b>901-410</b> 02.1984 →	D (A)	6	10965 cm <sup>3</sup>	2V		142,00 mm
<b>OM 421</b>	<b>901-500, 901-510</b> 02.1984 →	D (LA)	6	10965 cm <sup>3</sup>	2V		142,00 mm
<b>OM 424</b>	<b>901-400</b> 1980 →	D (A)	12	21930 cm <sup>3</sup>	2V		142,00 mm
<b>OM 424</b>	<b>901-500, 901.510</b> 1980 →	D (LA)	12		2V	441 kW (600 PS)	142,00 mm

93 484 6..., 93 484 7..., 93 485 6..

	IN [1]	59,0 x 12 x 142,5	A/S - Cr -	- 30° - -	5 - III	A 403 053 09 01	<b>16117</b>
						A 422 050 00 26	
						A 422 050 02 26	
						A 422 050 05 26	
						A 422 053 01 01	
						A 423 050 00 26	
						A 442 050 02 26	
						A 442 050 03 26	
	IN [1]	59,0 x 12 x 142,5	A/S - Cr -	- 30° - -	5 - III	A 442 050 05 26	
	IN [1]	59,0 x 12 x 142,5	S - Cr -	- 30° - VS -	5 - III	A 423 050 00 26	
	EX [1]	51,0 x 12 x 142,5	RA/S- Cr -	- 45° - -	5 - III	A 422 050 01 27	<b>16150</b>
						A 422 050 02 27	
						A 442 050 01 27	
						A 442 050 02 27	
						A 442 050 03 27	
						A 442 050 04 27	
	EX [1]	51,1 x 12 x 142,5	A/S - Cr -	- 45° - -	5 - III	A 423 050 04 27	<b>1608</b>

Fortsetzung nächste Seite / continued on next page / suite page suivante / continuación página próxima / Продолжение на следующей странице

					Reference	Item No.
[50] [50]	Ø 12 mm				A 000 053 04 26 A 422 053 00 26	LK-1605 LK-1610
IN/EX [6] IN/EX [6] IN/EX [6]	18,03 x 12 x 67,0 18,03 x 12 x 67,0 18,23 x 12 x 67,0	G1 G2 G1			A 403 053 00 30 A 422 053 04 30 A 403 053 01 30	81-1647 81-16100 81-1648
IN [2]  IN [2] IN [1] IN [1] IN [1] EX [2] EX [2]  EX [1] EX [1] EX [1]  EX [1]  EX [1]	60,11 x 51 x 8,9  60,11 x 51.2 x 8,4 60,31 x 51 x 9,1 60,31 x 51.2 x 8,6 60,51 x 51 x 9,3 53,11 x 43 x 9,2 53,11 x 43 x 9,7  53,11 x 43 x 9,2 53,31 x 43 x 9,4 53,31 x 43 x 9,9  53,51 x 43 x 10,2  53,51 x 43.2 x 9,6	G1 30°  G1 30° G1 30° G1 30° G1 30° G1 45° G1 45°  G1 45° G1 45° G1 45°  G1 45°  G1 45°			A 403 053 09 31 A 403 053 15 31 A 422 053 05 31 A 403 053 10 31 A 422 053 06 31 A 403 053 11 31 A 442 053 00 32 A 403 053 00 32 A 403 053 03 32 A 403 053 21 32 A 403 053 25 32 A 403 053 28 32 A 422 053 01 32 A 442 053 01 32 A 403 053 01 32 A 403 053 13 32 A 403 053 22 32 A 403 053 26 32 A 403 053 29 32 A 403 053 02 32 A 403 053 23 32 A 403 053 27 32 A 403 053 30 32 A 442 053 02 32	92-16100  92-16151 92-16147 92-16152 92-16101 92-16127 92-16104  92-16126 92-16149 92-16148  92-16105  92-16128
[12]  [12]  (1) (2)	M 32 x 76 x 20  M 32 x 76 x 20   (1) OES specification (2) IAM specification				A 422 050 03 25 A 476 050 00 25 A 422 050 03 25 A 476 050 00 25	20 1003 44000 (1)  20 1003 44001 <b>NEW</b> (2)
[4]  [1]  [1]  (3) (4)					A 403 050 07 33 A 442 050 03 33 A 403 050 03 33 A 403 050 07 33 A 442 050 03 33 A 403 050 03 33 A 403 050 07 33 A 442 050 03 33 A 442 055 00 20	20 1002 25010 (3)  20 1003 40010  20 1003 40012 (4)
Fortsetzung nächste Seite / continued on next page / suite page suivante / continuación página próxima / Продолжение на следующей странице						

M

					Reference	Item No.
	- - G - S -	- - -			A 402 010 03 20 A 403 010 40 20 A 403 010 89 20 A 427 010 00 20 A 427 010 10 20 A 429 010 02 20 A 442 010 07 20	<b>20 0803 40300</b>
	- V - G - S -	- - -	ready-to-install		A 427 010 10 20	<b>20 0803 40301</b>

**380** **128**

<b>OM 423</b>	<b>901</b>	D (A)	10	18273 cm <sup>3</sup>	2V	184-418 kW	(250-568 PS)	16,25:1	142,00 mm
<b>OM 424</b>	<b>901</b>	D (LA)	12	21927 cm <sup>3</sup>	2V	441 kW	(600 PS)	16,25:1	142,00 mm
1980 →									
93 484 6.., 93 484 7.., 93 485 6..									

	IN [1]	59,0 x 12 x 142,5	A/S - Cr -	- 30° - -	5 - III	A 403 053 09 01 A 422 050 00 26 A 422 050 02 26 A 422 050 05 26 A 422 053 01 01 A 423 050 00 26 A 442 050 02 26 A 442 050 03 26	<b>16117</b>
	IN [1]	59,0 x 12 x 142,5	A/S - Cr -	- 30° - -	5 - III	A 442 050 05 26	<b>16146</b>
	IN [1]	59,0 x 12 x 142,5	S - Cr -	- 30° - VS -	5 - III	A 423 050 00 26	<b>1606</b>
	EX [1]	51,0 x 12 x 142,5	A/S - Cr -	- 45° - -	5 - III	A 422 050 00 27	<b>16116</b>
	EX [1]	51,0 x 12 x 142,5	RA/S- Cr -	- 45° - -	5 - III	A 422 050 01 27 A 422 050 02 27 A 442 050 01 27 A 442 050 02 27 A 442 050 03 27 A 442 050 04 27	<b>16150</b>
	EX [1]	51,1 x 12 x 142,5	A/S - Cr -	- 45° - -	5 - III	A 423 050 04 27	<b>1608</b>
	[50]	Ø 12 mm				A 422 053 00 26	<b>LK-1610</b>
	IN/EX [6]	18,03 x 12 x 67,0	G1			A 403 053 00 30	<b>81-1647</b>
	IN/EX [6]	18,03 x 12 x 67,0	G2			A 422 053 04 30	<b>81-16100</b>
	IN/EX [6]	18,23 x 12 x 67,0	G1			A 403 053 01 30	<b>81-1648</b>

Fortsetzung nächste Seite / continued on next page / suite page suivante / continuación página próxima / Продолжение на следующей странице

					Reference	Item No.
	IN [2] 60,11 x 51 x 8,9	G1 30°			A 403 053 09 31 A 403 053 15 31	<b>92-16100</b>
	IN [2] 60,11 x 51.2 x 8,4	G1 30°			A 422 053 05 31	<b>92-16151</b>
	IN [1] 60,31 x 51 x 9,1	G1 30°			A 403 053 10 31	<b>92-16147</b>
	IN [1] 60,31 x 51.2 x 8,6	G1 30°			A 422 053 06 31	<b>92-16152</b>
	IN [1] 60,51 x 51 x 9,3	G1 30°			A 403 053 11 31	<b>92-16101</b>
	EX [2] 53,11 x 43 x 9,2	G1 45°			A 442 053 00 32	<b>92-16127</b>
	EX [2] 53,11 x 43 x 9,7	G1 45°			A 403 053 00 32 A 403 053 03 32 A 403 053 21 32 A 403 053 25 32 A 403 053 28 32	<b>92-16104</b>
	EX [1] 53,11 x 43 x 9,2	G1 45°			A 422 053 01 32	<b>92-16126</b>
	EX [1] 53,31 x 43 x 9,4	G1 45°			A 442 053 01 32	<b>92-16149</b>
	EX [1] 53,31 x 43 x 9,9	G1 45°			A 403 053 01 32 A 403 053 13 32 A 403 053 22 32 A 403 053 26 32 A 403 053 29 32	<b>92-16148</b>
	EX [1] 53,51 x 43 x 10,2	G1 45°			A 403 053 02 32 A 403 053 23 32 A 403 053 27 32 A 403 053 30 32	<b>92-16105</b>
	EX [1] 53,51 x 43.2 x 9,6	G1 45°			A 442 053 02 32	<b>92-16128</b>
	[4]				A 403 050 07 33 A 442 050 03 33	<b>20 1002 25010</b> (1)
	[1]				A 403 050 03 33 A 403 050 07 33 A 442 050 03 33	<b>20 1003 40010</b>
	[1]				A 403 050 03 33 A 403 050 07 33 A 442 050 03 33 A 442 055 00 20	<b>20 1003 40012</b> (2)
	(1) nur 2-Ventiler/only 2 valves version/seulement 2 soupapes/sólo sistemas de 2 válvulas/заменяемо 2 Клапаны					
	(2) mit Einstellschraube/with adjusting screw/avec vis de réglage/con tornillo de ajuste/c установочным винтом					

## 381 128

<b>OM 422</b>	<b>951 - 952, 954, 956 - 959, 963</b>	08.1980 →	D (A)	8	14618 cm <sup>3</sup>	2V	243-276 kW	(330-375 PS)	16,25:1	142,00 mm
<b>OM 422</b>	<b>953, 955</b>	11.1980 → 06.1990	D (LA)	8	14618 cm <sup>3</sup>	2V	276 kW	(375 PS)	16,25:1	142,00 mm

93 484 6..., 93 484 7..., 93 485 6...

	IN [1] 59,0 x 12 x 142,5	A/S - Cr -	- 30° -	-	5 - III	A 403 053 09 01 A 422 050 00 26 A 422 050 02 26 A 422 050 05 26 A 422 053 01 01 A 423 050 00 26 A 442 050 02 26 A 442 050 03 26	<b>16117</b>
	IN [1] 59,0 x 12 x 142,5	A/S - Cr -	- 30° -	-	5 - III	A 442 050 05 26	<b>16146</b>
	IN [1] 59,0 x 12 x 142,5	S - Cr -	- 30° -	VS -	5 - III	A 423 050 00 26	<b>1606</b>
	EX [1] 51,0 x 12 x 142,5	A/S - Cr -	- 45° -	-	5 - III	A 422 050 00 27	<b>16116</b>
	EX [1] 51,0 x 12 x 142,5	RA/S- Cr -	- 45° -	-	5 - III	A 422 050 01 27 A 422 050 02 27 A 442 050 01 27 A 442 050 02 27 A 442 050 03 27 A 442 050 04 27	<b>16150</b>
	EX [1] 51,1 x 12 x 142,5	A/S - Cr -	- 45° -	-	5 - III	A 423 050 04 27	<b>1608</b>

Fortsetzung nächste Seite / continued on next page / suite page suivante / continuación página próxima / Продолжение на следующей странице



					Reference	Item No.
[50] [50]	Ø 12 mm				A 000 053 04 26 A 422 053 00 26	LK-1605 LK-1610
IN/EX [6] IN/EX [6] IN/EX [6]	18,03 x 12 x 67,0 18,03 x 12 x 67,0 18,23 x 12 x 67,0	G1 G2 G1			A 403 053 00 30 A 422 053 04 30 A 403 053 01 30	81-1647 81-16100 81-1648
IN [2] IN [2] IN [1] IN [1] IN [1] EX [2] EX [2]	60,11 x 51 x 8,9 60,11 x 51.2 x 8,4 60,31 x 51 x 9,1 60,31 x 51.2 x 8,6 60,51 x 51 x 9,3 53,11 x 43 x 9,2 53,11 x 43 x 9,7	G1 30° G1 30° G1 30° G1 30° G1 30° G1 45° G1 45°			A 403 053 09 31 A 403 053 15 31 A 422 053 05 31 A 403 053 10 31 A 422 053 06 31 A 403 053 11 31 A 442 053 00 32 A 403 053 00 32 A 403 053 03 32 A 403 053 21 32 A 403 053 25 32 A 403 053 28 32 A 422 053 01 32 A 442 053 01 32 A 403 053 01 32 A 403 053 13 32 A 403 053 22 32 A 403 053 26 32 A 403 053 29 32 A 403 053 02 32 A 403 053 23 32 A 403 053 27 32 A 403 053 30 32 A 442 053 02 32	92-16100 92-16151 92-16147 92-16152 92-16101 92-16127 92-16104  92-16126 92-16149 92-16148  92-16105  92-16128
EX [1] EX [1] EX [1]	53,11 x 43 x 9,2 53,31 x 43 x 9,4 53,31 x 43 x 9,9	G1 45° G1 45° G1 45°			A 403 053 01 32 A 403 053 13 32 A 403 053 22 32 A 403 053 26 32 A 403 053 29 32 A 403 053 02 32 A 403 053 23 32 A 403 053 27 32 A 403 053 30 32 A 442 053 02 32	92-16126 92-16149 92-16148
EX [1]	53,51 x 43 x 10,2	G1 45°			A 403 053 02 32 A 403 053 23 32 A 403 053 27 32 A 403 053 30 32 A 442 053 02 32	92-16105  92-16128
EX [1]	53,51 x 43.2 x 9,6	G1 45°			A 442 053 02 32	92-16128
	724 mm				A 422 050 00 01 A 422 050 04 01 A 422 050 10 01 A 422 050 22 01	20 1003 42201
[12] [12] [12]	M 31,5 x 76,5 x 20 M 32 x 76 x 20 M 32 x 76 x 20				A 403 054 09 01 A 403 054 18 01 A 422 050 03 25 A 476 050 00 25 A 422 050 03 25 A 476 050 00 25	20 1003 40060 20 1003 44000 (1) 20 1003 44001 <b>NEW</b> (2)
	(1) OES specification (2) IAM specification					
[4] [1] [1]					A 403 050 07 33 A 442 050 03 33 A 403 050 03 33 A 403 050 07 33 A 442 050 03 33 A 403 050 03 33 A 403 050 07 33 A 442 050 03 33 A 442 055 00 20	20 1002 25010 (3) 20 1003 40010 20 1003 40012 (4)
	(3) nur 2-Ventiler/only 2 valves version/seulement 2 soupapes/sólo sistemas de 2 válvulas/заменяемо 2 Клапаны (4) mit Einstellschraube/with adjusting screw/avec vis de réglage/con tornillo de ajuste/c установочным винтом					
Fortsetzung nächste Seite / continued on next page / suite page suivante / continuación página próxima / Продолжение на следующей странице						

M

					Reference	Item No.
	- - G - S -	- - - -			A 402 010 03 20 A 403 010 40 20 A 403 010 89 20 A 427 010 00 20 A 427 010 10 20 A 429 010 02 20 A 442 010 07 20	<b>20 0803 40300</b>
	- V - G - S -	- - - -	ready-to-install		A 427 010 10 20	<b>20 0803 40301</b>

## 382 128

<b>OM 421</b>	<b>905</b>								
	10.1981 →	D (NA)	6	10964 cm <sup>3</sup>	2V	159 kW	(216 PS)	16,9:1	142,00 mm
<b>OM 423</b>	<b>905, 909</b>								
	10.1981 → 09.1996	D (NA)	10	18273 cm <sup>3</sup>	2V	261 kW	(355 PS)	16,9:1	142,00 mm
<b>OM 423</b>	<b>906 - 908</b>								
	01.1981 →	D (A)	10	18273 cm <sup>3</sup>	2V	261 kW	(355 PS)	16,9:1	142,00 mm
<b>OM 427</b>	<b>905, 910 - 911</b>								
	12.1984 →	D (NA)	6	11967 cm <sup>3</sup>	2V	150-177 kW	(204-240 PS)	16,6:1	155,00 mm

93 484 6..., 93 484 7..., 93 990 6..

	IN [1]	59,0 x 12 x 142,5	A/S - Cr -	- 30° -	-	5 - III	A 403 053 09 01 A 422 050 00 26 A 422 050 02 26 A 422 050 05 26 A 422 053 01 01 A 423 050 00 26 A 442 050 02 26 A 442 050 03 26	<b>16117</b>
	IN [1]	59,0 x 12 x 142,5	A/S - Cr -	- 30° -	-	5 - III	A 442 050 05 26	<b>16146</b>
	IN [1]	59,0 x 12 x 142,5	S - Cr -	- 30° -	VS -	5 - III	A 423 050 00 26	<b>1606</b>
	EX [1]	51,0 x 12 x 142,5	A/S - Cr -	- 45° -	-	5 - III	A 422 050 00 27	<b>16116</b>
	EX [1]	51,0 x 12 x 142,5	RA/S- Cr -	- 45° -	-	5 - III	A 422 050 01 27 A 422 050 02 27 A 442 050 01 27 A 442 050 02 27 A 442 050 03 27 A 442 050 04 27	<b>16150</b>
	EX [1]	51,1 x 12 x 142,5	A/S - Cr -	- 45° -	-	5 - III	A 423 050 04 27	<b>1608</b>
	[50]						A 000 053 04 26	<b>LK-1605</b>
	[50]	Ø 12 mm					A 422 053 00 26	<b>LK-1610</b>
	IN/EX [6]	18,03 x 12 x 67,0	G1				A 403 053 00 30	<b>81-1647</b>
	IN/EX [6]	18,03 x 12 x 67,0	G2				A 422 053 04 30	<b>81-16100</b>
	IN/EX [6]	18,23 x 12 x 67,0	G1				A 403 053 01 30	<b>81-1648</b>

Fortsetzung nächste Seite / continued on next page / suite page suivante / continuación página próxima / Продолжение на следующей странице

					Reference	Item No.
	IN [2]	60,11 x 51 x 8,9	G1 30°		A 403 053 09 31 A 403 053 15 31	<b>92-16100</b>
	IN [1]	60,31 x 51 x 9,1	G1 30°		A 403 053 10 31	<b>92-16147</b>
	IN [1]	60,51 x 51 x 9,3	G1 30°		A 403 053 11 31	<b>92-16101</b>
	EX [2]	53,11 x 43 x 9,7	G1 45°		A 403 053 00 32 A 403 053 03 32 A 403 053 21 32 A 403 053 25 32 A 403 053 28 32	<b>92-16104</b>
	EX [1]	53,31 x 43 x 9,9	G1 45°		A 403 053 01 32 A 403 053 13 32 A 403 053 22 32 A 403 053 26 32 A 403 053 29 32	<b>92-16148</b>
	EX [1]	53,51 x 43 x 10,2	G1 45°		A 403 053 02 32 A 403 053 23 32 A 403 053 27 32 A 403 053 30 32	<b>92-16105</b>
	[12]	M 31,5 x 76,5 x 20			A 403 054 09 01 A 403 054 18 01	<b>20 1003 40060</b>
	[12]	M 32 x 76 x 20			A 422 050 03 25 A 476 050 00 25	<b>20 1003 44000</b> (1)
	[12]	M 32 x 76 x 20			A 422 050 03 25 A 476 050 00 25	<b>20 1003 44001</b> <span style="border: 1px solid black; padding: 1px;">NEW</span> (2)
	(1) OES specification (2) IAM specification					
	[4]				A 403 050 07 33 A 442 050 03 33	<b>20 1002 25010</b> (3)
	[1]				A 403 050 03 33 A 403 050 07 33 A 442 050 03 33	<b>20 1003 40010</b>
	[1]				A 403 050 03 33 A 403 050 07 33 A 442 050 03 33 A 442 055 00 20	<b>20 1003 40012</b> (4)
	(3) nur 2-Ventiler/only 2 valves version/seulement 2 soupapes/sólo sistemas de 2 válvulas/заменяемо 2 Клапаны (4) mit Einstellschraube/with adjusting screw/avec vis de réglage/con tornillo de ajuste/c установочным ВИНТОМ					
	- - G - S -	- - -			A 402 010 03 20 A 403 010 40 20 A 403 010 89 20 A 427 010 00 20 A 427 010 10 20 A 429 010 02 20 A 442 010 07 20	<b>20 0803 40300</b>
		- V - G - S -	- - -	ready-to-install	A 427 010 10 20	<b>20 0803 40301</b>

M

					Reference	Item No.		
<b>383</b>		<b>128</b>						
<b>OM 492</b>	<b>900-405 (AFS), 900-406 (AFS), 900-409 (AFS), 900-411 (AFS)</b>							
	10.1984 →	D (A)	8	14618 cm <sup>3</sup>	2V	221-243 kW (300-330 PS) 16,25:1 142,00 mm		
<b>OM 492</b>	<b>900-501 (AFS)</b>							
	10.1984 → 12.1986	D (LA)	8	14618 cm <sup>3</sup>	2V	276 kW (375 PS) 16,25:1 142,00 mm		
<b>OM 493</b>	<b>900-001 (AFS), 900-501 (AFS)</b>							
	11.1981 →	D	10	18273 cm <sup>3</sup>	2V	261-368 kW (355-500 PS) 16,9:1 142,00 mm		
93 484 6..., 93 484 7..., 93 485 6..								
	IN [1]	59,0 x 12 x 142,5	A/S - Cr -	- 30° -	-	5 - III	A 403 053 09 01 A 422 050 00 26 A 422 050 02 26 A 422 050 05 26 A 422 053 01 01 A 423 050 00 26 A 442 050 02 26 A 442 050 03 26	<b>16117</b>
	IN [1]	59,0 x 12 x 142,5	A/S - Cr -	- 30° -	-	5 - III	A 442 050 05 26	<b>16146</b>
	EX [1]	51,0 x 12 x 142,5	RA/S- Cr -	- 45° -	-	5 - III	A 422 050 01 27 A 422 050 02 27 A 442 050 01 27 A 442 050 02 27 A 442 050 03 27 A 442 050 04 27	<b>16150</b>
	[50]	Ø 12 mm					A 422 053 00 26	<b>LK-1610</b>
	IN/EX [6]	18,03 x 12 x 67,0	G1				A 403 053 00 30	<b>81-1647</b>
	IN/EX [6]	18,03 x 12 x 67,0	G2				A 422 053 04 30	<b>81-16100</b>
	IN/EX [6]	18,23 x 12 x 67,0	G1				A 403 053 01 30	<b>81-1648</b>
	IN [2]	60,11 x 51 x 8,9	G1 30°				A 403 053 09 31 A 403 053 15 31	<b>92-16100</b>
	IN [2]	60,11 x 51.2 x 8,4	G1 30°				A 422 053 05 31	<b>92-16151</b>
	IN [1]	60,31 x 51 x 9,1	G1 30°				A 403 053 10 31	<b>92-16147</b>
	IN [1]	60,31 x 51.2 x 8,6	G1 30°				A 422 053 06 31	<b>92-16152</b>
	IN [1]	60,51 x 51 x 9,3	G1 30°				A 403 053 11 31	<b>92-16101</b>
	EX [2]	53,11 x 43 x 9,2	G1 45°				A 442 053 00 32	<b>92-16127</b>
	EX [2]	53,11 x 43 x 9,7	G1 45°				A 403 053 00 32 A 403 053 03 32 A 403 053 21 32 A 403 053 25 32 A 403 053 28 32	<b>92-16104</b>
	EX [1]	53,11 x 43 x 9,2	G1 45°				A 422 053 01 32	<b>92-16126</b>
	EX [1]	53,31 x 43 x 9,4	G1 45°				A 442 053 01 32	<b>92-16149</b>
	EX [1]	53,31 x 43 x 9,9	G1 45°				A 403 053 01 32 A 403 053 13 32 A 403 053 22 32 A 403 053 26 32 A 403 053 29 32	<b>92-16148</b>
	EX [1]	53,51 x 43 x 10,2	G1 45°				A 403 053 02 32 A 403 053 23 32 A 403 053 27 32 A 403 053 30 32	<b>92-16105</b>
	EX [1]	53,51 x 43.2 x 9,6	G1 45°				A 442 053 02 32	<b>92-16128</b>
	[1]						A 403 050 03 33 A 403 050 07 33 A 442 050 03 33	<b>20 1003 40010</b>
	[1]						A 403 050 03 33 A 403 050 07 33 A 442 050 03 33 A 442 055 00 20	<b>20 1003 40012 (1)</b>
	(1) mit Einstellschraube/with adjusting screw/avec vis de réglage/con tornillo de ajuste/c установочным винтом							

**M**

					Reference	Item No.	
<b>384</b>		<b>128</b>					
<b>OM 421</b>	<b>907</b>						
93 484 6..., 93 484 7..							
05.1982 → 03.1991 D (NA) 6 10964 cm <sup>3</sup> 2V 159 kW (216 PS) 16,9:1 142,00 mm							
	IN [1]	59,0 x 12 x 142,5	A/S - Cr -	- 30° - -	5 - III	A 403 053 09 01 A 422 050 00 26 A 422 050 02 26 A 422 050 05 26 A 422 053 01 01 A 423 050 00 26 A 442 050 02 26 A 442 050 03 26	<b>16117</b>
	IN [1]	59,0 x 12 x 142,5	A/S - Cr -	- 30° - -	5 - III	A 442 050 05 26	<b>16146</b>
	IN [1]	59,0 x 12 x 142,5	S - Cr -	- 30° - VS -	5 - III	A 423 050 00 26	<b>1606</b>
	EX [1]	51,0 x 12 x 142,5	A/S - Cr -	- 45° - -	5 - III	A 422 050 00 27	<b>16116</b>
	EX [1]	51,0 x 12 x 142,5	RA/S- Cr -	- 45° - -	5 - III	A 422 050 01 27 A 422 050 02 27 A 442 050 01 27 A 442 050 02 27 A 442 050 03 27 A 442 050 04 27	<b>16150</b>
	EX [1]	51,1 x 12 x 142,5	A/S - Cr -	- 45° - -	5 - III	A 423 050 04 27	<b>1608</b>
	[50]					A 000 053 04 26	<b>LK-1605</b>
	[50]	Ø 12 mm				A 422 053 00 26	<b>LK-1610</b>
	IN/EX [6]	18,03 x 12 x 67,0	G2			A 422 053 04 30	<b>81-16100</b>
	IN [2]	60,11 x 51 x 8,9	G1 30°			A 403 053 09 31 A 403 053 15 31	<b>92-16100</b>
	IN [1]	60,31 x 51 x 9,1	G1 30°			A 403 053 10 31	<b>92-16147</b>
	IN [1]	60,51 x 51 x 9,3	G1 30°			A 403 053 11 31	<b>92-16101</b>
	EX [2]	53,11 x 43 x 9,7	G1 45°			A 403 053 00 32 A 403 053 03 32 A 403 053 21 32 A 403 053 25 32 A 403 053 28 32	<b>92-16104</b>
	EX [1]	53,31 x 43 x 9,9	G1 45°			A 403 053 01 32 A 403 053 13 32 A 403 053 22 32 A 403 053 26 32 A 403 053 29 32	<b>92-16148</b>
	EX [1]	53,51 x 43 x 10,2	G1 45°			A 403 053 02 32 A 403 053 23 32 A 403 053 27 32 A 403 053 30 32	<b>92-16105</b>
	[12]	M 31,5 x 76,5 x 20				A 403 054 09 01 A 403 054 18 01	<b>20 1003 40060</b>
	[12]	M 32 x 76 x 20				A 422 050 03 25 A 476 050 00 25	<b>20 1003 44000</b> (1)
	[12]	M 32 x 76 x 20				A 422 050 03 25 A 476 050 00 25	<b>20 1003 44001</b> <b>NEW</b> (2)
	(1)	OES specification					
	(2)	IAM specification					
Fortsetzung nächste Seite / continued on next page / suite page suivante / continuación página próxima / Продолжение на следующей странице							



					Reference	Item No.
[4]					A 403 050 07 33 A 442 050 03 33	20 1002 25010 (3)
[1]					A 403 050 03 33 A 403 050 07 33 A 442 050 03 33	20 1003 40010
[1]					A 403 050 03 33 A 403 050 07 33 A 442 050 03 33 A 442 055 00 20	20 1003 40012 (4)
(3)	nur 2-Ventiler/only 2 valves version/seulement 2 soupapes/sólo sistemas de 2 válvulas/заменяемо 2 Клапаны					
(4)	mit Einstellschraube/with adjusting screw/avec vis de réglage/con tornillo de ajuste/c установочным винтом					
	- - G - S -	- - -			A 402 010 03 20 A 403 010 40 20 A 403 010 89 20 A 427 010 00 20 A 427 010 10 20 A 429 010 02 20 A 442 010 07 20	20 0803 40300
	- V - G - S -	- - -	ready-to-install		A 427 010 10 20	20 0803 40301

**385**
**128**
**OM 481**
**902**

05.1982→

 D (NA) 6 10965 cm<sup>3</sup> 2V

159 kW

(216 PS) 16,9:1 142,00 mm

93 484 6.., 93 484 7..

IN [1]	59,0 x 12 x 142,5	A/S - Cr -	- 30° - -	5 - III	A 403 053 09 01 A 422 050 00 26 A 422 050 02 26 A 422 050 05 26 A 422 053 01 01 A 423 050 00 26 A 442 050 02 26 A 442 050 03 26	16117
IN [1]	59,0 x 12 x 142,5	A/S - Cr -	- 30° - -	5 - III	A 442 050 05 26	16146
EX [1]	51,0 x 12 x 142,5	RA/S- Cr -	- 45° - -	5 - III	A 422 050 01 27 A 422 050 02 27 A 442 050 01 27 A 442 050 02 27 A 442 050 03 27 A 442 050 04 27	16150
[50]	Ø 12 mm				A 422 053 00 26	LK-1610
IN/EX [6]	18,03 x 12 x 67,0	G2			A 422 053 04 30	81-16100
Fortsetzung nächste Seite / continued on next page / suite page suivante / continuación página próxima / Продолжение на следующей странице						

					Reference	Item No.
IN [2]	60,11 x 51 x 8,9	G1 30°			A 403 053 09 31 A 403 053 15 31	<b>92-16100</b>
IN [1]	60,31 x 51 x 9,1	G1 30°			A 403 053 10 31	<b>92-16147</b>
IN [1]	60,51 x 51 x 9,3	G1 30°			A 403 053 11 31	<b>92-16101</b>
EX [2]	53,11 x 43 x 9,7	G1 45°			A 403 053 00 32 A 403 053 03 32 A 403 053 21 32 A 403 053 25 32 A 403 053 28 32	<b>92-16104</b>
EX [1]	53,31 x 43 x 9,9	G1 45°			A 403 053 01 32 A 403 053 13 32 A 403 053 22 32 A 403 053 26 32 A 403 053 29 32	<b>92-16148</b>
EX [1]	53,51 x 43 x 10,2	G1 45°			A 403 053 02 32 A 403 053 23 32 A 403 053 27 32 A 403 053 30 32	<b>92-16105</b>
[12]	M 32 x 76 x 20				A 422 050 03 25 A 476 050 00 25	<b>20 1003 44000</b> (1)
[12]	M 32 x 76 x 20				A 422 050 03 25 A 476 050 00 25	<b>20 1003 44001</b> (2)
	(1) OES specification					
	(2) IAM specification					
[1]					A 403 050 03 33 A 403 050 07 33 A 442 050 03 33	<b>20 1003 40010</b>
[1]					A 403 050 03 33 A 403 050 07 33 A 442 050 03 33 A 442 055 00 20	<b>20 1003 40012</b> (3)
	(3) mit Einstellschraube/with adjusting screw/avec vis de réglage/con tornillo de ajuste/c установочным винтом					
	- - G - S -	- - -			A 402 010 03 20 A 403 010 40 20 A 403 010 89 20 A 427 010 00 20 A 427 010 10 20 A 429 010 02 20 A 442 010 07 20	<b>20 0803 40300</b>
	- V - G - S -	- - -	ready-to-install		A 427 010 10 20	<b>20 0803 40301</b>

**386**
**128**
**OM 423**
**901-510**

D (LA) 10 18273 cm<sup>3</sup> 2V 346 kW (470 PS) 16,25:1 142,00 mm

**OM 423**
**901-400, 901-500**

1984 →

D (A) 10 18273 cm<sup>3</sup> 2V 142,00 mm

93 484 6.., 93 484 7.., 93 485 6..

Fortsetzung nächste Seite / continued on next page / suite page suivante / continuación página próxima / Продолжение на следующей странице

					Reference	Item No.
	IN [1] 59,0 x 12 x 142,5	A/S - Cr -	- 30° - -	5 - III	A 403 053 09 01 A 422 050 00 26 A 422 050 02 26 A 422 050 05 26 A 422 053 01 01 A 423 050 00 26 A 442 050 02 26 A 442 050 03 26	<b>16117</b>
	IN [1] 59,0 x 12 x 142,5	A/S - Cr -	- 30° - -	5 - III	A 442 050 05 26	<b>16146</b>
	IN [1] 59,0 x 12 x 142,5	S - Cr -	- 30° - VS -	5 - III	A 423 050 00 26	<b>1606</b>
	EX [1] 51,0 x 12 x 142,5	A/S - Cr -	- 45° - -	5 - III	A 422 050 00 27	<b>16116</b>
	EX [1] 51,0 x 12 x 142,5	RA/S- Cr -	- 45° - -	5 - III	A 422 050 01 27 A 422 050 02 27 A 442 050 01 27 A 442 050 02 27 A 442 050 03 27 A 442 050 04 27	<b>16150</b>
	EX [1] 51,1 x 12 x 142,5	A/S - Cr -	- 45° - -	5 - III	A 423 050 04 27	<b>1608</b>
	[50] [50] Ø 12 mm				A 000 053 04 26 A 422 053 00 26	<b>LK-1605</b> <b>LK-1610</b>
	IN/EX [6] 18,03 x 12 x 67,0 IN/EX [6] 18,03 x 12 x 67,0 IN/EX [6] 18,23 x 12 x 67,0	G1 G2 G1			A 403 053 00 30 A 422 053 04 30 A 403 053 01 30	<b>81-1647</b> <b>81-16100</b> <b>81-1648</b>
	IN [2] 60,11 x 51 x 8,9 IN [2] 60,11 x 51.2 x 8,4 IN [1] 60,31 x 51 x 9,1 IN [1] 60,31 x 51.2 x 8,6 IN [1] 60,51 x 51 x 9,3 EX [2] 53,11 x 43 x 9,2 EX [2] 53,11 x 43 x 9,7	G1 30° G1 30° G1 30° G1 30° G1 30° G1 45° G1 45°			A 403 053 09 31 A 403 053 15 31 A 422 053 05 31 A 403 053 10 31 A 422 053 06 31 A 403 053 11 31 A 442 053 00 32 A 403 053 00 32 A 403 053 03 32 A 403 053 21 32 A 403 053 25 32 A 403 053 28 32	<b>92-16100</b> <b>92-16151</b> <b>92-16147</b> <b>92-16152</b> <b>92-16101</b> <b>92-16127</b> <b>92-16104</b>
	EX [1] 53,11 x 43 x 9,2 EX [1] 53,31 x 43 x 9,4 EX [1] 53,31 x 43 x 9,9	G1 45° G1 45° G1 45°			A 422 053 01 32 A 442 053 01 32 A 403 053 01 32 A 403 053 13 32 A 403 053 22 32 A 403 053 26 32 A 403 053 29 32	<b>92-16126</b> <b>92-16149</b> <b>92-16148</b>
	EX [1] 53,51 x 43 x 10,2	G1 45°			A 403 053 02 32 A 403 053 23 32 A 403 053 27 32 A 403 053 30 32	<b>92-16105</b>
	EX [1] 53,51 x 43.2 x 9,6	G1 45°			A 442 053 02 32	<b>92-16128</b>
	[12] M 32 x 76 x 20 [12] M 32 x 76 x 20 (1) OES specification (2) IAM specification				A 422 050 03 25 A 476 050 00 25 A 422 050 03 25 A 476 050 00 25	<b>20 1003 44000</b> (1) <b>20 1003 44001</b> <b>NEW</b> (2)
Fortsetzung nächste Seite / continued on next page / suite page suivante / continuación página próxima / Продолжение на следующей странице						

**M**

					Reference	Item No.
[4]					A 403 050 07 33	<b>20 1002 25010</b> (3)
[1]					A 442 050 03 33	<b>20 1003 40010</b>
[1]					A 403 050 03 33	<b>20 1003 40012</b> (4)
					A 403 050 07 33	
					A 442 050 03 33	
					A 403 050 07 33	
					A 442 050 03 33	
					A 442 055 00 20	
(3)	nur 2-Ventiler/only 2 valves version/seulement 2 soupapes/sólo sistemas de 2 válvulas/заменяемо 2 Клапаны					
(4)	mit Einstellschraube/with adjusting screw/avec vis de réglage/con tornillo de ajuste/c установочным ВИНТОМ					
	- - G - S -	- - - -			A 402 010 03 20	<b>20 0803 40300</b>
					A 403 010 40 20	
					A 403 010 89 20	
					A 427 010 00 20	
					A 427 010 10 20	
					A 429 010 02 20	
					A 442 010 07 20	
	- V - G - S -	- - - -	ready-to-install		A 427 010 10 20	<b>20 0803 40301</b>

**387**
**128**
**OM 423**
**950**

 01.1984→09.1996 D (LA) 10 18273 cm<sup>3</sup> 2V 368 kW (500 PS) 16,25:1 142,00 mm

93 485 6..

	IN [1]	59,0 x 12 x 142,5	A/S - Cr -	- 30° - -	5 - III	A 403 053 09 01	<b>16117</b>
						A 422 050 00 26	
						A 422 050 02 26	
						A 422 050 05 26	
						A 422 053 01 01	
						A 423 050 00 26	
						A 442 050 02 26	
						A 442 050 03 26	
	IN [1]	59,0 x 12 x 142,5	A/S - Cr -	- 30° - -	5 - III	A 442 050 05 26	<b>16146</b>
	IN [1]	59,0 x 12 x 142,5	S - Cr -	- 30° - VS -	5 - III	A 423 050 00 26	<b>1606</b>
	EX [1]	51,0 x 12 x 142,5	A/S - Cr -	- 45° - -	5 - III	A 422 050 00 27	<b>16116</b>
	EX [1]	51,0 x 12 x 142,5	RA/S- Cr -	- 45° - -	5 - III	A 422 050 01 27	<b>16150</b>
						A 422 050 02 27	
						A 442 050 01 27	
						A 442 050 02 27	
						A 442 050 03 27	
						A 442 050 04 27	
	EX [1]	51,1 x 12 x 142,5	A/S - Cr -	- 45° - -	5 - III	A 423 050 04 27	<b>1608</b>
	[50]					A 000 053 04 26	<b>LK-1605</b>
	[50]	Ø 12 mm				A 422 053 00 26	<b>LK-1610</b>

Fortsetzung nächste Seite / continued on next page / suite page suivante / continuación página próxima / Продолжение на следующей странице

					Reference	Item No.
	IN/EX [6]	18,03 x 12 x 67,0	G1		A 403 053 00 30	<b>81-1647</b>
	IN/EX [6]	18,03 x 12 x 67,0	G2		A 422 053 04 30	<b>81-16100</b>
	IN/EX [6]	18,23 x 12 x 67,0	G1		A 403 053 01 30	<b>81-1648</b>
	IN [2]	60,11 x 51 x 8,9	G1 30°		A 403 053 09 31	<b>92-16100</b>
					A 403 053 15 31	
	IN [2]	60,11 x 51.2 x 8,4	G1 30°		A 422 053 05 31	<b>92-16151</b>
	IN [1]	60,31 x 51 x 9,1	G1 30°		A 403 053 10 31	<b>92-16147</b>
	IN [1]	60,31 x 51.2 x 8,6	G1 30°		A 422 053 06 31	<b>92-16152</b>
	IN [1]	60,51 x 51 x 9,3	G1 30°		A 403 053 11 31	<b>92-16101</b>
	EX [2]	53,11 x 43 x 9,2	G1 45°		A 442 053 00 32	<b>92-16127</b>
	EX [2]	53,11 x 43 x 9,7	G1 45°		A 403 053 00 32	<b>92-16104</b>
					A 403 053 03 32	
					A 403 053 21 32	
					A 403 053 25 32	
					A 403 053 28 32	
	EX [1]	53,11 x 43 x 9,2	G1 45°		A 422 053 01 32	<b>92-16126</b>
	EX [1]	53,31 x 43 x 9,4	G1 45°		A 442 053 01 32	<b>92-16149</b>
	EX [1]	53,31 x 43 x 9,9	G1 45°		A 403 053 01 32	<b>92-16148</b>
				A 403 053 13 32		
				A 403 053 22 32		
				A 403 053 26 32		
				A 403 053 29 32		
EX [1]	53,51 x 43 x 10,2	G1 45°		A 403 053 02 32	<b>92-16105</b>	
				A 403 053 23 32		
				A 403 053 27 32		
				A 403 053 30 32		
EX [1]	53,51 x 43.2 x 9,6	G1 45°		A 442 053 02 32	<b>92-16128</b>	
	[12]	M 31,5 x 76,5 x 20			A 403 054 09 01	<b>20 1003 40060</b>
					A 403 054 18 01	
	[12]	M 32 x 76 x 20			A 422 050 03 25	<b>20 1003 44000</b> (1)
	[12]	M 32 x 76 x 20			A 476 050 00 25	
				A 422 050 03 25	<b>20 1003 44001</b> <small>NEW</small>	
				A 476 050 00 25	(2)	
	(1) OES specification					
	(2) IAM specification					
	[4]				A 403 050 07 33	<b>20 1002 25010</b> (3)
					A 442 050 03 33	
	[1]				A 403 050 03 33	<b>20 1003 40010</b>
				A 403 050 07 33		
				A 442 050 03 33		
[1]				A 403 050 03 33	<b>20 1003 40012</b> (4)	
				A 403 050 07 33		
				A 442 050 03 33		
				A 442 055 00 20		
	(3) nur 2-Ventiler/only 2 valves version/seulement 2 soupapes/sólo sistemas de 2 válvulas/заменяемо 2 Клапаны					
	(4) mit Einstellschraube/with adjusting screw/avec vis de réglage/con tornillo de ajuste/c установочным винтом					
Fortsetzung nächste Seite / continued on next page / suite page suivante / continuación página próxima / Продолжение на следующей странице						

M



					Reference	Item No.
	- - G - S -	- - -			A 402 010 03 20 A 403 010 40 20 A 403 010 89 20 A 427 010 00 20 A 427 010 10 20 A 429 010 02 20 A 442 010 07 20	<b>20 0803 40300</b>
	- V - G - S -	- - -	ready-to-install		A 427 010 10 20	<b>20 0803 40301</b>

**388**
**128**
**OM 466**
**900-005 (AFS), 900-505**

01.1984 →

D (A)

6

 11970 cm<sup>3</sup> 2V

175-265 kW

(238-360 PS) 16,25

155,00 mm

	IN [1]	59,0 x 12 x 142,5	A/S - Cr -	- 30° - -	5 - III	A 403 053 09 01 A 422 050 00 26 A 422 050 02 26 A 422 050 05 26 A 422 053 01 01 A 423 050 00 26 A 442 050 02 26 A 442 050 03 26	<b>16117</b>	
	IN [1] EX [2]	59,0 x 12 x 142,5 17,1 x 8 x 90,3	A/S - Cr - A - -	- 30° - - - 45° - -	5 - III 1 -	A 442 050 05 26 A 442 016 02 91 A 442 016 03 91	<b>16146</b> <b>50 004 665</b> (1)	
	EX [1]	51,0 x 12 x 142,5	RA/S- Cr -	- 45° - -	5 - III	A 422 050 01 27 A 422 050 02 27 A 442 050 01 27 A 442 050 02 27 A 442 050 03 27 A 442 050 04 27	<b>16150</b>	
	(1)	Konstantdrosselventil - Dom Exhaust brake valve - dome Papillon constant - Dôme Válvula de estrangulamiento constante - Dom Нерегулируемый дроссельный клапан - сбор						
	[50]	Ø 12 mm				A 422 053 00 26	<b>LK-1610</b>	
	IN/EX [6]	18,03 x 12 x 67,0	G2			A 422 053 04 30	<b>81-16100</b>	
	IN [1]	60,11 x 49,3 x 8,4	G1 30°			A 422 053 01 31 A 447 053 00 31	<b>92-16150</b>	
	EX [2]	53,11 x 43 x 9,2	G1 45°			A 442 053 00 32	<b>92-16127</b>	
	EX [1]	53,11 x 43 x 9,2	G1 45°			A 422 053 01 32	<b>92-16126</b>	
	EX [1]	53,31 x 43 x 9,4	G1 45°			A 442 053 01 32	<b>92-16149</b>	
	EX [1]	53,51 x 43,2 x 9,6	G1 45°			A 442 053 02 32	<b>92-16128</b>	

Fortsetzung nächste Seite / continued on next page / suite page suivante / continuación página próxima / Продолжение на следующей странице

					Reference	Item No.
	[1]				A 403 050 03 33	<b>20 1003 40010</b>
	[1]				A 403 050 07 33	<b>20 1003 40012 (2)</b>
					A 442 050 03 33	
					A 403 050 03 33	
					A 403 050 07 33	
					A 442 050 03 33	
					A 442 055 00 20	
	(2) mit Einstellschraube/with adjusting screw/avec vis de réglage/con tornillo de ajuste/c установочным винтом					

**389**
**128**
**OM 421**
**901/-400**

02.1984 →

 D (A) 6 10965 cm<sup>3</sup> 2V

142,00 mm

93 485 6..

	IN [1]	59,0 x 12 x 142,5	A/S - Cr -	- 30° -	-	5 - III	A 403 053 09 01 A 422 050 00 26 A 422 050 02 26 A 422 050 05 26 A 422 053 01 01 A 423 050 00 26 A 442 050 02 26 A 442 050 03 26	<b>16117</b>
	IN [1]	59,0 x 12 x 142,5	A/S - Cr -	- 30° -	-	5 - III	A 442 050 05 26	<b>16146</b>
	IN [1]	59,0 x 12 x 142,5	S - Cr -	- 30° -	VS -	5 - III	A 423 050 00 26	<b>1606</b>
	EX [1]	51,0 x 12 x 142,5	A/S - Cr -	- 45° -	-	5 - III	A 422 050 00 27	<b>16116</b>
	EX [1]	51,0 x 12 x 142,5	RA/S- Cr -	- 45° -	-	5 - III	A 422 050 01 27 A 422 050 02 27 A 442 050 01 27 A 442 050 02 27 A 442 050 03 27 A 442 050 04 27	<b>16150</b>
	EX [1]	51,1 x 12 x 142,5	A/S - Cr -	- 45° -	-	5 - III	A 423 050 04 27	<b>1608</b>
	[50]	Ø 12 mm					A 000 053 04 26	<b>LK-1605</b>
	[50]						A 422 053 00 26	<b>LK-1610</b>
	IN/EX [6]	18,03 x 12 x 67,0	G2				A 422 053 04 30	<b>81-16100</b>
	IN [2]	60,11 x 51.2 x 8,4	G1 30°				A 422 053 05 31	<b>92-16151</b>
	IN [1]	60,31 x 51.2 x 8,6	G1 30°				A 422 053 06 31	<b>92-16152</b>
	EX [2]	53,11 x 43 x 9,2	G1 45°				A 442 053 00 32	<b>92-16127</b>
	EX [1]	53,11 x 43 x 9,2	G1 45°				A 422 053 01 32	<b>92-16126</b>
	EX [1]	53,31 x 43 x 9,4	G1 45°				A 442 053 01 32	<b>92-16149</b>
	EX [1]	53,51 x 43.2 x 9,6	G1 45°				A 442 053 02 32	<b>92-16128</b>
	[12]	M 32 x 76 x 20					A 422 050 03 25 A 476 050 00 25	<b>20 1003 44000 (1)</b>
	[12]	M 32 x 76 x 20					A 422 050 03 25 A 476 050 00 25	<b>20 1003 44001 <sup>NEW</sup> (2)</b>
		(1) OES specification						
		(2) IAM specification						
	[4]						A 403 050 07 33 A 442 050 03 33	<b>20 1002 25010 (3)</b>
	[1]						A 403 050 03 33 A 403 050 07 33 A 442 050 03 33	<b>20 1003 40010</b>
	[1]						A 403 050 03 33 A 403 050 07 33 A 442 050 03 33 A 442 055 00 20	<b>20 1003 40012 (4)</b>
	(3) nur 2-Ventiler/only 2 valves version/seulement 2 soupapes/sólo sistemas de 2 válvulas/заменяемо 2 Клапаны							

Fortsetzung nächste Seite / continued on next page / suite page suivante / continuación página próxima / Продолжение на следующей странице

					Reference	Item No.
(4)	mit Einstellschraube/with adjusting screw/avec vis de réglage/con tornillo de ajuste/с установочным ВИНТОМ					
	- - G - S -	- - -			A 402 010 03 20 A 403 010 40 20 A 403 010 89 20 A 427 010 00 20 A 427 010 10 20 A 429 010 02 20 A 442 010 07 20	<b>20 0803 40300</b>
	- V - G - S -	- - -	ready-to-install		A 427 010 10 20	<b>20 0803 40301</b>

**M**
**390** **128**

**OM 442 Euro 0** 941 - 946, 950, 952, 954 - 955, 957 - 959  
1985 → D (A) 8 14618 cm<sup>3</sup> 2V 260-269 kW (354-366 PS) 16,25:1 142,00 mm

**OM 442 Euro 0** 951, 953  
01.1985 → 03.1992 D (LA) 8 14618 cm<sup>3</sup> 2V 320-329 kW (435-447 PS) 16,25:1 142,00 mm

90 220 6.., 91 630 6.., 94 512 6.., 99 973 6..

	IN [1]	59,0 x 12 x 142,5	A/S - Cr -	- 30° - -	5 - III	A 403 053 09 01 A 422 050 00 26 A 422 050 02 26 A 422 050 05 26 A 422 053 01 01 A 423 050 00 26 A 442 050 02 26 A 442 050 03 26	<b>16117</b>	
	IN [1] EX [2]	59,0 x 12 x 142,5 17,1 x 8 x 90,3	A/S - Cr - A - -	- 30° - - - 45° - -	5 - III 1 -	A 442 050 05 26 A 442 016 02 91 A 442 016 03 91	<b>16146</b> <b>50 004 665</b> (1)	
	EX [1]	51,0 x 12 x 142,5	RA/S- Cr -	- 45° - -	5 - III	A 422 050 01 27 A 422 050 02 27 A 442 050 01 27 A 442 050 02 27 A 442 050 03 27 A 442 050 04 27	<b>16150</b>	
	(1)	Konstantdrosselventil - Dom Exhaust brake valve - dome Papillon constant - Dôme Válvula de estrangulamiento constante - Dom Нерегулируемый дроссельный клапан - собор						
	[50]	Ø 12 mm				A 422 053 00 26	<b>LK-1610</b>	
	IN/EX [6]	18,03 x 12 x 67,0	G2			A 422 053 04 30	<b>81-16100</b>	
Fortsetzung nächste Seite / continued on next page / suite page suivante / continuación página próxima / Продолжение на следующей странице								

					Reference	Item No.
	IN [2]	60,11 x 51.2 x 8,4	G1 30°		A 422 053 05 31	<b>92-16151</b>
	IN [1]	60,31 x 51.2 x 8,6	G1 30°		A 422 053 06 31	<b>92-16152</b>
	EX [2]	53,11 x 43 x 9,2	G1 45°		A 442 053 00 32	<b>92-16127</b>
	EX [1]	53,11 x 43 x 9,2	G1 45°		A 422 053 01 32	<b>92-16126</b>
	EX [1]	53,31 x 43 x 9,4	G1 45°		A 442 053 01 32	<b>92-16149</b>
	EX [1]	53,51 x 43.2 x 9,6	G1 45°		A 442 053 02 32	<b>92-16128</b>
	724 mm				A 422 050 00 01 A 422 050 04 01 A 422 050 10 01 A 422 050 22 01	<b>20 1003 42201</b>
	[12]	M 31,5 x 76,5 x 20			A 403 054 09 01 A 403 054 18 01	<b>20 1003 40060</b>
	[12]	M 32 x 76 x 20			A 422 050 03 25 A 476 050 00 25	<b>20 1003 44000</b> (2)
	[12]	M 32 x 76 x 20			A 422 050 03 25 A 476 050 00 25	<b>20 1003 44001</b> <small>NEW</small> (3)
	(2) OES specification					
	(3) IAM specification					
	[4]				A 403 050 07 33 A 442 050 03 33	<b>20 1002 25010</b> (4)
	[1]				A 403 050 03 33 A 403 050 07 33 A 442 050 03 33	<b>20 1003 40010</b>
	[1]				A 403 050 03 33 A 403 050 07 33 A 442 050 03 33 A 442 055 00 20	<b>20 1003 40012</b> (5)
	(4) nur 2-Ventiler/only 2 valves version/seulement 2 soupapes/sólo sistemas de 2 válvulas/заменяемо 2 Клапаны					
	(5) mit Einstellschraube/with adjusting screw/avec vis de réglage/con tornillo de ajuste/c установочным винтом					
	- - G - S -	- - -			A 402 010 03 20 A 403 010 40 20 A 403 010 89 20 A 427 010 00 20 A 427 010 10 20 A 429 010 02 20 A 442 010 07 20	<b>20 0803 40300</b>
	- V - G - S -	- - -	ready-to-install		A 427 010 10 20	<b>20 0803 40301</b>

M

					Reference	Item No.	
<b>391</b>		<b>128</b>					
<b>OM 442 Euro 0</b>		<b>980, 982 - 984, 992</b>					
		01.1985 → 09.1996	D (LA)	8	14618 cm <sup>3</sup> 2V	320-362 kW (435-492 PS) 16,25:1 142,00 mm	
<b>OM 442</b>		<b>989</b>					
		01.1985 → 09.1996	D (LA)	8	14618 cm <sup>3</sup> 2V	362 kW (492 PS) 16,25:1 142,00 mm	
<b>OM 442 Euro 0</b>		<b>960 - 968, 971 - 972, 976</b>					
		1985 →	D (A)	8	14618 cm <sup>3</sup> 2V	260-269 kW (354-366 PS) 16,25:1 142,00 mm	
90 220 6..., 91 630 6..., 94 512 6..., 99 973 6..							
	IN [1]	59,0 x 12 x 142,5	A/S - Cr -	- 30° -	- 5 - III	A 403 053 09 01 A 422 050 00 26 A 422 050 02 26 A 422 050 05 26 A 422 053 01 01 A 423 050 00 26 A 442 050 02 26 A 442 050 03 26	<b>16117</b>
	IN [1]	59,0 x 12 x 142,5	A/S - Cr -	- 30° -	- 5 - III	A 442 050 05 26	<b>16146</b>
	EX [1]	51,0 x 12 x 142,5	RA/S- Cr -	- 45° -	- 5 - III	A 422 050 01 27 A 422 050 02 27 A 442 050 01 27 A 442 050 02 27 A 442 050 03 27 A 442 050 04 27	<b>16150</b>
	[50]	∅ 12 mm				A 422 053 00 26	<b>LK-1610</b>
	IN/EX [6]	18,03 x 12 x 67,0	G2			A 422 053 04 30	<b>81-16100</b>
	IN [2]	60,11 x 51.2 x 8,4	G1 30°			A 422 053 05 31	<b>92-16151</b>
	IN [1]	60,31 x 51.2 x 8,6	G1 30°			A 422 053 06 31	<b>92-16152</b>
	EX [2]	53,11 x 43 x 9,2	G1 45°			A 442 053 00 32	<b>92-16127</b>
	EX [1]	53,11 x 43 x 9,2	G1 45°			A 422 053 01 32	<b>92-16126</b>
	EX [1]	53,31 x 43 x 9,4	G1 45°			A 442 053 01 32	<b>92-16149</b>
	EX [1]	53,51 x 43.2 x 9,6	G1 45°			A 442 053 02 32	<b>92-16128</b>
		724 mm				A 422 050 00 01 A 422 050 04 01 A 422 050 10 01 A 422 050 22 01	<b>20 1003 42201</b>
	[12]	M 31,5 x 76,5 x 20				A 403 054 09 01 A 403 054 18 01	<b>20 1003 40060</b>
	[12]	M 32 x 76 x 20				A 422 050 03 25 A 476 050 00 25	<b>20 1003 44000</b> (1)
	[12]	M 32 x 76 x 20				A 422 050 03 25 A 476 050 00 25	<b>20 1003 44001</b> <b>NEW</b> (2)
	(1)	OES specification					
	(2)	IAM specification					
	[4]					A 403 050 07 33 A 442 050 03 33	<b>20 1002 25010</b> (3)
	[1]					A 403 050 03 33 A 403 050 07 33 A 442 050 03 33	<b>20 1003 40010</b>
	[1]					A 403 050 03 33 A 403 050 07 33 A 442 050 03 33 A 442 055 00 20	<b>20 1003 40012</b> (4)
	(3)	nur 2-Ventiler/only 2 valves version/seulement 2 soupapes/sólo sistemas de 2 válvulas/заменяемо 2 Клапаны					
	(4)	mit Einstellschraube/with adjusting screw/avec vis de réglage/con tornillo de ajuste/c установочным винтом					

Fortsetzung nächste Seite / continued on next page / suite page suivante / continuación página próxima / Продолжение на следующей странице



					Reference	Item No.
	- - G - S -	- - -			A 402 010 03 20 A 403 010 40 20 A 403 010 89 20 A 427 010 00 20 A 427 010 10 20 A 429 010 02 20 A 442 010 07 20	<b>20 0803 40300</b>
		- V - G - S -	- - -	ready-to-install	A 427 010 10 20	<b>20 0803 40301</b>

## 392 128

<b>OM 442 Euro 0</b>	<b>975</b>	1985 → 02.1991	D (A)	8	14618 cm <sup>3</sup>	2V	269 kW	(366 PS)	16,25:1	142,00 mm
<b>OM 442 Euro 0</b>	<b>991</b>		D (LA)	8	14618 cm <sup>3</sup>	2V	362 kW	(492 PS)	16,25:1	142,00 mm

90 220 6.., 91 630 6.., 94 512 6.., 99 973 6..

	IN [1]	59,0 x 12 x 142,5	A/S - Cr -	- 30° -	-	5 - III	A 403 053 09 01 A 422 050 00 26 A 422 050 02 26 A 422 050 05 26 A 422 053 01 01 A 423 050 00 26 A 442 050 02 26 A 442 050 03 26	<b>16117</b>
	IN [1]	59,0 x 12 x 142,5	A/S - Cr -	- 30° -	-	5 - III	A 442 050 05 26	<b>16146</b>
	EX [1]	51,0 x 12 x 142,5	RA/S- Cr -	- 45° -	-	5 - III	A 422 050 01 27 A 422 050 02 27 A 442 050 01 27 A 442 050 02 27 A 442 050 03 27 A 442 050 04 27	<b>16150</b>
	[50]	Ø 12 mm					A 422 053 00 26	<b>LK-1610</b>
	IN/EX [6]	18,03 x 12 x 67,0	G2				A 422 053 04 30	<b>81-16100</b>
	IN [2]	60,11 x 51.2 x 8,4	G1 30°				A 422 053 05 31	<b>92-16151</b>
	IN [1]	60,31 x 51.2 x 8,6	G1 30°				A 422 053 06 31	<b>92-16152</b>
	EX [2]	53,11 x 43 x 9,2	G1 45°				A 442 053 00 32	<b>92-16127</b>
	EX [1]	53,11 x 43 x 9,2	G1 45°				A 422 053 01 32	<b>92-16126</b>
	EX [1]	53,31 x 43 x 9,4	G1 45°				A 442 053 01 32	<b>92-16149</b>
	EX [1]	53,51 x 43.2 x 9,6	G1 45°				A 442 053 02 32	<b>92-16128</b>

## 393 128

<b>OM 429</b>	<b>951</b>	01.1985 → 12.2001	D (LA)	5	9970 cm <sup>3</sup>	2V	175 kW	(235 PS)	17,25:1	155,00 mm
---------------	------------	-------------------	--------	---	----------------------	----	--------	----------	---------	-----------

93 990 6..

Fortsetzung nächste Seite / continued on next page / suite page suivante / continuación página próxima / Продолжение на следующей странице

						Reference	Item No.
	IN [1] 59,0 x 12 x 142,5	A/S - Cr -	- 30° - -	5 - III		A 403 053 09 01 A 422 050 00 26 A 422 050 02 26 A 422 050 05 26 A 422 053 01 01 A 423 050 00 26 A 442 050 02 26 A 442 050 03 26	<b>16117</b>
	IN [1] EX [1] 59,0 x 12 x 142,5 51,0 x 12 x 142,5	A/S - Cr - RA/S- Cr -	- 30° - - - 45° - -	5 - III 5 - III		A 442 050 05 26 A 422 050 01 27 A 422 050 02 27 A 442 050 01 27 A 442 050 02 27 A 442 050 03 27 A 442 050 04 27	<b>16146</b> <b>16150</b>
	[50] Ø 12 mm					A 422 053 00 26	<b>LK-1610</b>
	IN/EX [6] IN/EX [6] IN/EX [6] 18,03 x 12 x 67,0 18,03 x 12 x 67,0 18,23 x 12 x 67,0	G1 G2 G1				A 403 053 00 30 A 422 053 04 30 A 403 053 01 30	<b>81-1647</b> <b>81-16100</b> <b>81-1648</b>
	IN [1] EX [2] EX [1] EX [1] EX [1] 60,11 x 49.3 x 8,4 53,11 x 43 x 9,2 53,11 x 43 x 9,2 53,31 x 43 x 9,4 53,51 x 43.2 x 9,6	G1 30° G1 45° G1 45° G1 45° G1 45°				A 422 053 01 31 A 447 053 00 31 A 442 053 00 32 A 422 053 01 32 A 442 053 01 32 A 442 053 02 32	<b>92-16150</b> <b>92-16127</b> <b>92-16126</b> <b>92-16149</b> <b>92-16128</b>
	[1] [1]					A 403 050 03 33 A 403 050 07 33 A 442 050 03 33 A 403 050 03 33 A 403 050 07 33 A 442 050 03 33 A 442 055 00 20	<b>20 1003 40010</b> <b>20 1003 40012 (1)</b>
	(1) mit Einstellschraube/with adjusting screw/avec vis de réglage/con tornillo de ajuste/c установочным винтом						

## 394 128

OM 429

953

01.1985 → 12.2001 D (A) 5 9970 cm<sup>3</sup> 2V 186 kW (250 PS) 17,25:1 155,00 mm

93 990 6..

	IN [1] 59,0 x 12 x 142,5	A/S - Cr -	- 30° - -	5 - III		A 403 053 09 01 A 422 050 00 26 A 422 050 02 26 A 422 050 05 26 A 422 053 01 01 A 423 050 00 26 A 442 050 02 26 A 442 050 03 26	<b>16117</b>
	IN [1] EX [1] 59,0 x 12 x 142,5 51,0 x 12 x 142,5	A/S - Cr - RA/S- Cr -	- 30° - - - 45° - -	5 - III 5 - III		A 442 050 05 26 A 422 050 01 27 A 422 050 02 27 A 442 050 01 27 A 442 050 02 27 A 442 050 03 27 A 442 050 04 27	<b>16146</b> <b>16150</b>
	[50] Ø 12 mm					A 422 053 00 26	<b>LK-1610</b>
	IN/EX [6] IN/EX [6] IN/EX [6] 18,03 x 12 x 67,0 18,03 x 12 x 67,0 18,23 x 12 x 67,0	G1 G2 G1				A 403 053 00 30 A 422 053 04 30 A 403 053 01 30	<b>81-1647</b> <b>81-16100</b> <b>81-1648</b>

Fortsetzung nächste Seite / continued on next page / suite page suivante / continuación página próxima / Продолжение на следующей странице

					Reference	Item No.
	IN [2] 60,11 x 51.2 x 8,4 IN [1] 60,11 x 49.3 x 8,4	G1 30° G1 30°			A 422 053 05 31 A 422 053 01 31 A 447 053 00 31	<b>92-16151</b> <b>92-16150</b>
	IN [1] 60,31 x 51.2 x 8,6 EX [2] 53,11 x 43 x 9,2 EX [1] 53,11 x 43 x 9,2 EX [1] 53,31 x 43 x 9,4 EX [1] 53,51 x 43.2 x 9,6	G1 30° G1 45° G1 45° G1 45° G1 45°			A 422 053 06 31 A 442 053 00 32 A 422 053 01 32 A 442 053 01 32 A 442 053 02 32	<b>92-16152</b> <b>92-16127</b> <b>92-16126</b> <b>92-16149</b> <b>92-16128</b>
	[1]  [1]				A 403 050 03 33 A 403 050 07 33 A 442 050 03 33 A 403 050 03 33 A 403 050 07 33 A 442 050 03 33 A 442 055 00 20	<b>20 1003 40010</b>  <b>20 1003 40012 (1)</b>
	(1) mit Einstellschraube/with adjusting screw/avec vis de réglage/con tornillo de ajuste/с установочным винтом					
	- - G - S -	- - -			A 402 010 03 20 A 403 010 40 20 A 403 010 89 20 A 427 010 00 20 A 427 010 10 20 A 429 010 02 20 A 442 010 07 20	<b>20 0803 40300</b>
	- V - G - S -	- - -	ready-to-install		A 427 010 10 20	<b>20 0803 40301</b>

## 395 128

OM 429 **955**  
01.1985 → 12.2001 D (LA) 5 9970 cm<sup>3</sup> 2V 186 kW (250 PS) 17,25:1 155,00 mm  
93 990 6..

	IN [1] 59,0 x 12 x 142,5	A/S - Cr -	- 30° -	5 - III	A 403 053 09 01 A 422 050 00 26 A 422 050 02 26 A 422 050 05 26 A 422 053 01 01 A 423 050 00 26 A 442 050 02 26 A 442 050 03 26	<b>16117</b>
	IN [1] EX [1] 59,0 x 12 x 142,5 51,0 x 12 x 142,5	A/S - Cr - RA/S- Cr -	- 30° - - 45° -	5 - III 5 - III	A 442 050 05 26 A 422 050 01 27 A 422 050 02 27 A 442 050 01 27 A 442 050 02 27 A 442 050 03 27 A 442 050 04 27	<b>16146</b> <b>16150</b>
	[50] Ø 12 mm				A 422 053 00 26	<b>LK-1610</b>

Fortsetzung nächste Seite / continued on next page / suite page suivante / continuación página próxima / Продолжение на следующей странице

					Reference	Item No.
	IN/EX [6] 18,03 x 12 x 67,0	G2			A 422 053 04 30	<b>81-16100</b>
	IN [1] 60,11 x 49.3 x 8,4	G1 30°			A 422 053 01 31 A 447 053 00 31	<b>92-16150</b>
	EX [2] 53,11 x 43 x 9,2	G1 45°			A 442 053 00 32	<b>92-16127</b>
	EX [1] 53,11 x 43 x 9,2	G1 45°			A 422 053 01 32	<b>92-16126</b>
	EX [1] 53,31 x 43 x 9,4	G1 45°			A 442 053 01 32	<b>92-16149</b>
	EX [1] 53,51 x 43.2 x 9,6	G1 45°			A 442 053 02 32	<b>92-16128</b>
	[1]				A 403 050 03 33 A 403 050 07 33 A 442 050 03 33	<b>20 1003 40010</b>
	[1]				A 403 050 03 33 A 403 050 07 33 A 442 050 03 33 A 442 055 00 20	<b>20 1003 40012 (1)</b>
(1) mit Einstellschraube/with adjusting screw/avec vis de réglage/con tornillo de ajuste/c установочным ВИНТОМ						

**396**
**128**
**OM 347**
**915, 942 - 943**

D (NA) 5 9651 cm<sup>3</sup> 2V 141-147 kW (192-200 PS) 17,2:1 150,00 mm

93 568 6..

**M**

	IN [2] 42,0 x 9 x 129,8	S - Cr -	- 45° - -	5 - III	A 345 053 71 01 A 346 053 00 01 A 346 053 01 01 A 346 053 03 01	<b>1657</b>
	EX [2] 37,0 x 9 x 165,3	A/S - Cr -	- 45° - -	5 - III	A 345 053 71 05 A 346 053 01 05 A 346 053 02 05 A 355 050 01 27	<b>1658</b>
	IN [6] 15,04 x 9 x 68,5	G1			A 346 053 09 29	<b>81-1640</b>
	IN [4] 15,20 x 9 x 67,5	G1			A 346 053 11 29	<b>81-1642</b>
	EX [6] 15,00 x 9 x 86,5	G1			A 355 053 03 30	<b>81-1641</b>
	IN [2] 51,06 x 37 x 7,5	G1 45°			A 346 053 07 31 A 355 053 11 31	<b>92-16106</b>
	IN [1] 51,26 x 37 x 7,5	G1 45°			A 346 053 08 31	<b>92-16140</b>
	IN [1] 51,46 x 37 x 7,5	G1 45°			A 355 053 09 31 A 355 053 13 31	<b>92-16142</b>
	EX [2] 40,10 x 31 x 7,5	G1 45°			A 345 053 01 32 A 346 053 05 32 A 355 053 06 32 A 355 053 10 32 A 355 053 18 32	<b>92-16110</b>
	EX [1] 40,26 x 31 x 7,5	G1 45°			A 346 053 06 32	<b>92-16141</b>
	EX [1] 40,46 x 31 x 7,5	G1 45°			A 355 053 12 32 A 355 053 20 32	<b>92-16143</b>

**397**
**128**
**OM 421**
**951**

11.1985 → 04.1989 D (A) 6 10964 cm<sup>3</sup> 2V 184 kW (250 PS) 16,25:1 142,00 mm

93 484 6.., 93 484 7.., 93 485 6..

Fortsetzung nächste Seite / continued on next page / suite page suivante / continuación página próxima / Продолжение на следующей странице

					Reference	Item No.
	IN [1] 59,0 x 12 x 142,5	A/S - Cr -	- 30° - -	5 - III	A 403 053 09 01 A 422 050 00 26 A 422 050 02 26 A 422 050 05 26 A 422 053 01 01 A 423 050 00 26 A 442 050 02 26 A 442 050 03 26	<b>16117</b>
	IN [1] 59,0 x 12 x 142,5	A/S - Cr -	- 30° - -	5 - III	A 442 050 05 26	<b>16146</b>
	IN [1] 59,0 x 12 x 142,5	S - Cr -	- 30° - VS -	5 - III	A 423 050 00 26	<b>1606</b>
	EX [1] 51,0 x 12 x 142,5	RA/S- Cr -	- 45° - -	5 - III	A 422 050 01 27 A 422 050 02 27 A 442 050 01 27 A 442 050 02 27 A 442 050 03 27 A 442 050 04 27	<b>16150</b>
	EX [1] 51,1 x 12 x 142,5	A/S - Cr -	- 45° - -	5 - III	A 423 050 04 27	<b>1608</b>
	[50] [50] Ø 12 mm				A 000 053 04 26 A 422 053 00 26	<b>LK-1605</b> <b>LK-1610</b>
	IN/EX [6] 18,03 x 12 x 67,0	G2			A 422 053 04 30	<b>81-16100</b>
	IN [2] 60,11 x 51.2 x 8,4	G1 30°			A 422 053 05 31	<b>92-16151</b>
	IN [1] 60,31 x 51.2 x 8,6	G1 30°			A 422 053 06 31	<b>92-16152</b>
	EX [2] 53,11 x 43 x 9,2	G1 45°			A 442 053 00 32	<b>92-16127</b>
	EX [1] 53,11 x 43 x 9,2	G1 45°			A 422 053 01 32	<b>92-16126</b>
	EX [1] 53,31 x 43 x 9,4	G1 45°			A 442 053 01 32	<b>92-16149</b>
	EX [1] 53,51 x 43.2 x 9,6	G1 45°			A 442 053 02 32	<b>92-16128</b>
	[12] M 31,5 x 76,5 x 20				A 403 054 09 01 A 403 054 18 01	<b>20 1003 40060</b>
	[12] M 32 x 76 x 20				A 422 050 03 25 A 476 050 00 25	<b>20 1003 44000</b> (1)
	[12] M 32 x 76 x 20				A 422 050 03 25 A 476 050 00 25	<b>20 1003 44001</b> <b>NEW</b> (2)
	(1) OES specification					
	(2) IAM specification					
	[4] [1] [1]				A 403 050 07 33 A 442 050 03 33 A 403 050 03 33 A 403 050 07 33 A 442 050 03 33 A 403 050 03 33 A 403 050 07 33 A 442 050 03 33 A 442 055 00 20	<b>20 1002 25010</b> (3) <b>20 1003 40010</b> <b>20 1003 40012</b> (4)
	(3) nur 2-Ventiler/only 2 valves version/seulement 2 soupapes/sólo sistemas de 2 válvulas/заменяемо 2 Клапаны					
	(4) mit Einstellschraube/with adjusting screw/avec vis de réglage/con tornillo de ajuste/c установочным винтом					

**398** **128**

**OM 441 Euro 0 950, 953**  
 11.1985→09.1992 D (A) 6 10964 cm<sup>3</sup> 2V 191-200 kW (260-272 PS) 16,25:1 142,00 mm  
 90 220 6.., 91 630 6.., 94 512 6.., 99 973 6..

Fortsetzung nächste Seite / continued on next page / suite page suivante / continuación página próxima / Продолжение на следующей странице



					Reference	Item No.
IN [1]	59,0 x 12 x 142,5	A/S - Cr -	- 30° - -	5 - III	A 403 053 09 01 A 422 050 00 26 A 422 050 02 26 A 422 050 05 26 A 422 053 01 01 A 423 050 00 26 A 442 050 02 26 A 442 050 03 26	<b>16117</b>
IN [1]	59,0 x 12 x 142,5	A/S - Cr -	- 30° - -	5 - III	A 442 050 05 26	<b>16146</b>
EX [1]	51,0 x 12 x 142,5	A/S - Cr -	- 45° - -	5 - III	A 422 050 00 27	<b>16116</b>
EX [1]	51,0 x 12 x 142,5	RA/S- Cr -	- 45° - -	5 - III	A 422 050 01 27 A 422 050 02 27 A 442 050 01 27 A 442 050 02 27 A 442 050 03 27 A 442 050 04 27	<b>16150</b>
[50]	Ø 12 mm				A 422 053 00 26	<b>LK-1610</b>
IN/EX [6]	18,03 x 12 x 67,0	G2			A 422 053 04 30	<b>81-16100</b>
IN [2]	60,11 x 51.2 x 8,4	G1 30°			A 422 053 05 31	<b>92-16151</b>
IN [1]	60,31 x 51.2 x 8,6	G1 30°			A 422 053 06 31	<b>92-16152</b>
EX [2]	53,11 x 43 x 9,2	G1 45°			A 442 053 00 32	<b>92-16127</b>
EX [1]	53,11 x 43 x 9,2	G1 45°			A 422 053 01 32	<b>92-16126</b>
EX [1]	53,31 x 43 x 9,4	G1 45°			A 442 053 01 32	<b>92-16149</b>
EX [1]	53,51 x 43.2 x 9,6	G1 45°			A 442 053 02 32	<b>92-16128</b>
[12]	M 31,5 x 76,5 x 20				A 403 054 09 01 A 403 054 18 01	<b>20 1003 40060</b>
[12]	M 32 x 76 x 20				A 422 050 03 25 A 476 050 00 25	<b>20 1003 44000</b> (1)
[12]	M 32 x 76 x 20				A 422 050 03 25 A 476 050 00 25	<b>20 1003 44001</b> <b>NEW</b> (2)
	(1) OES specification					
	(2) IAM specification					
[4]					A 403 050 07 33 A 442 050 03 33	<b>20 1002 25010</b> (3)
[1]					A 403 050 03 33 A 403 050 07 33 A 442 050 03 33	<b>20 1003 40010</b>
[1]					A 403 050 03 33 A 403 050 07 33 A 442 050 03 33 A 442 055 00 20	<b>20 1003 40012</b> (4)
	(3) nur 2-Ventiler/only 2 valves version/seulement 2 soupapes/sólo sistemas de 2 válvulas/заменяемо 2 Клапаны					
	(4) mit Einstellschraube/with adjusting screw/avec vis de réglage/con tornillo de ajuste/c установочным ВИНТОМ					
Fortsetzung nächste Seite / continued on next page / suite page suivante / continuación página próxima / Продолжение на следующей странице						

					Reference	Item No.
	- - G - S -	- - - -			A 402 010 03 20 A 403 010 40 20 A 403 010 89 20 A 427 010 00 20 A 427 010 10 20 A 429 010 02 20 A 442 010 07 20	<b>20 0803 40300</b>
	- V - G - S -	- - - -	ready-to-install		A 427 010 10 20	<b>20 0803 40301</b>

## 399 128

<b>OM 427</b>	<b>950 - 952</b>												
	11.1985 →	D	(A)	6	11967 cm <sup>3</sup>	2V	206 kW	(280 PS)	16,25:1	155,00 mm			
<b>OM 444 Euro 0</b>	<b>901.400</b>												
	05.1988 → 02.1991	D	(A)	12	21927 cm <sup>3</sup>	2V	344-422 kW	(468-574 PS)	16,25:1	142,00 mm			

90 220 6.., 91 630 6.., 93 990 6.., 94 512 6.., 99 973 6..

	IN [1]	59,0 x 12 x 142,5	A/S - Cr -	- 30° -	-	5 - III	A 403 053 09 01 A 422 050 00 26 A 422 050 02 26 A 422 050 05 26 A 422 053 01 01 A 423 050 00 26 A 442 050 02 26 A 442 050 03 26	<b>16117</b>
	IN [1]	59,0 x 12 x 142,5	A/S - Cr -	- 30° -	-	5 - III	A 442 050 05 26	<b>16146</b>
	EX [1]	51,0 x 12 x 142,5	RA/S- Cr -	- 45° -	-	5 - III	A 422 050 01 27 A 422 050 02 27 A 442 050 01 27 A 442 050 02 27 A 442 050 03 27 A 442 050 04 27	<b>16150</b>
	[50]	Ø 12 mm					A 422 053 00 26	<b>LK-1610</b>
	IN/EX [6]	18,03 x 12 x 67,0	G1				A 403 053 00 30	<b>81-1647</b>
	IN/EX [6]	18,03 x 12 x 67,0	G2				A 422 053 04 30	<b>81-16100</b>
	IN/EX [6]	18,23 x 12 x 67,0	G1				A 403 053 01 30	<b>81-1648</b>
	IN [2]	60,11 x 51.2 x 8,4	G1 30°				A 422 053 05 31	<b>92-16151</b>
	IN [1]	60,31 x 51.2 x 8,6	G1 30°				A 422 053 06 31	<b>92-16152</b>
	EX [2]	53,11 x 43 x 9,2	G1 45°				A 442 053 00 32	<b>92-16127</b>
	EX [1]	53,11 x 43 x 9,2	G1 45°				A 422 053 01 32	<b>92-16126</b>
	EX [1]	53,31 x 43 x 9,4	G1 45°				A 442 053 01 32	<b>92-16149</b>
	EX [1]	53,51 x 43.2 x 9,6	G1 45°				A 442 053 02 32	<b>92-16128</b>
	[12]	M 31,5 x 76,5 x 20					A 403 054 09 01 A 403 054 18 01	<b>20 1003 40060</b>
	[12]	M 32 x 76 x 20					A 422 050 03 25 A 476 050 00 25	<b>20 1003 44000</b> (1)
	[12]	M 32 x 76 x 20					A 422 050 03 25 A 476 050 00 25	<b>20 1003 44001</b> (2)

(1) OES specification

Fortsetzung nächste Seite / continued on next page / suite page suivante / continuación página próxima / Продолжение на следующей странице

					Reference	Item No.
(2)	IAM specification					
[4]					A 403 050 07 33	<b>20 1002 25010</b> (3)
[1]					A 442 050 03 33	<b>20 1003 40010</b>
[1]					A 403 050 03 33	<b>20 1003 40012</b> (4)
					A 403 050 07 33	
					A 442 050 03 33	
					A 403 050 03 33	
					A 403 050 07 33	
					A 442 050 03 33	
					A 442 055 00 20	
(3)	nur 2-Ventiler/only 2 valves version/seulement 2 soupapes/sólo sistemas de 2 válvulas/заменяемо 2 Клапаны					
(4)	mit Einstellschraube/with adjusting screw/avec vis de réglage/con tornillo de ajuste/c установочным ВИНТОМ					
	- - G - S -	- - - -			A 402 010 03 20	<b>20 0803 40300</b>
					A 403 010 40 20	
					A 403 010 89 20	
					A 427 010 00 20	
					A 427 010 10 20	
					A 429 010 02 20	
					A 442 010 07 20	
	- V - G - S -	- - - -	ready-to-install		A 427 010 10 20	<b>20 0803 40301</b>

## 400 128

OM 447 Euro 2

996

11.1985 →

D (LA) 6 11967 cm<sup>3</sup> 2V

184 kW

(250 PS) 18:1

155,00 mm

40 176 6.., 93 171 6..

	IN [1]	59,0 x 12 x 142,5	A/S - Cr -	- 30° - -	5 - III	A 403 053 09 01	<b>16117</b>
						A 422 050 00 26	
						A 422 050 02 26	
						A 422 050 05 26	
						A 422 053 01 01	
						A 423 050 00 26	
						A 442 050 02 26	
						A 442 050 03 26	
	IN [1]	59,0 x 12 x 142,5	A/S - Cr -	- 30° - -	5 - III	A 442 050 05 26	<b>16146</b>
	EX [1]	51,0 x 12 x 142,5	RA/S- Cr -	- 45° - -	5 - III	A 422 050 01 27	<b>16150</b>
						A 422 050 02 27	
						A 442 050 01 27	
						A 442 050 02 27	
						A 442 050 03 27	
						A 442 050 04 27	
	[50]	Ø 12 mm				A 422 053 00 26	<b>LK-1610</b>
	IN/EX [6]	18,03 x 12 x 67,0	G2			A 422 053 04 30	<b>81-16100</b>

Fortsetzung nächste Seite / continued on next page / suite page suivante / continuación página próxima / Продолжение на следующей странице

					Reference	Item No.
	EX [2] EX [1] EX [1] EX [1]	53,11 x 43 x 9,2 53,11 x 43 x 9,2 53,31 x 43 x 9,4 53,51 x 43.2 x 9,6	G1 45° G1 45° G1 45° G1 45°		A 442 053 00 32 A 422 053 01 32 A 442 053 01 32 A 442 053 02 32	<b>92-16127</b> <b>92-16126</b> <b>92-16149</b> <b>92-16128</b>
	1047 mm				A 447 050 19 01	<b>20 1003 44701</b>
	[12] [12] (1) OES specification (2) IAM specification	M 32 x 76 x 20 M 32 x 76 x 20			A 422 050 03 25 A 476 050 00 25 A 422 050 03 25 A 476 050 00 25	<b>20 1003 44000</b> (1) <b>20 1003 44001</b> <small>NEW</small> (2)
	[4] [1] [1] (3) nur 2-Ventiler/only 2 valves version/seulement 2 soupapes/sólo sistemas de 2 válvulas/заменяемо 2 Клапаны (4) mit Einstellschraube/with adjusting screw/avec vis de réglage/con tornillo de ajuste/c установочным винтом				A 403 050 07 33 A 442 050 03 33 A 403 050 03 33 A 403 050 07 33 A 442 050 03 33 A 403 050 03 33 A 403 050 07 33 A 442 050 03 33 A 442 055 00 20	<b>20 1002 25010</b> (3) <b>20 1003 40010</b> <b>20 1003 40012</b> (4)

## 401 128

<b>OM 475 Euro 1</b>	<b>994</b>	D (LA)	5	9973 cm <sup>3</sup>	2V	184 kW	(250 PS)	16,25:1	155,00 mm
<b>OM 475</b>	<b>907</b>	D (LA)	5	9973 cm <sup>3</sup>	2V	221 kW	(301 PS)	16,25:1	155,00 mm
<b>OM 475</b>	<b>950 - 954</b>	D (A)	5	9973 cm <sup>3</sup>	2V	184 kW	(250 PS)	16,25:1	155,00 mm
<b>OM 476</b>	<b>916, 950</b>	D (A)	6	11967 cm <sup>3</sup>	2V	213-246 kW	(290-335 PS)	16,25-1 6,6	155,00 mm
<b>OM 476 Euro 2</b>	<b>971 - 973, 977 - 980, 983</b>								
	05.1990 →	D (LA)	6	11967 cm <sup>3</sup>	2V	257-264 kW	(350-359 PS)		155,00 mm
<b>OM 476</b>	<b>917, 981 - 982, 988, 991 - 992</b>	D (LA)	6	11967 cm <sup>3</sup>	2V	257-310 kW	(350-422 PS)		155,00 mm

40 111 6..., 91 467 6..., 93 990 6..

	IN [1]  IN [1] EX [1]	59,0 x 12 x 142,5  59,0 x 12 x 142,5 51,0 x 12 x 142,5	A/S - Cr -  A/S - Cr - RA/S- Cr -	- 30° -  - 30° - - 45° -	-  - -	5 - III  5 - III 5 - III	A 403 053 09 01 A 422 050 00 26 A 422 050 02 26 A 422 050 05 26 A 422 053 01 01 A 423 050 00 26 A 442 050 02 26 A 442 050 03 26 A 442 050 05 26 A 422 050 01 27 A 422 050 02 27 A 442 050 01 27 A 442 050 02 27 A 442 050 03 27 A 442 050 04 27	<b>16117</b>  <b>16146</b> <b>16150</b>
	[50]	Ø 12 mm					A 422 053 00 26	<b>LK-1610</b>

Fortsetzung nächste Seite / continued on next page / suite page suivante / continuación página próxima / Продолжение на следующей странице

					Reference	Item No.
IN/EX [6]	18,03 x 12 x 67,0	G2			A 422 053 04 30	<b>81-16100</b>
IN [1]	60,11 x 49.3 x 8,4	G1 30°			A 422 053 01 31 A 447 053 00 31	<b>92-16150</b>
EX [2]	53,11 x 43 x 9,2	G1 45°			A 442 053 00 32	<b>92-16127</b>
EX [1]	53,11 x 43 x 9,2	G1 45°			A 422 053 01 32	<b>92-16126</b>
EX [1]	53,31 x 43 x 9,4	G1 45°			A 442 053 01 32	<b>92-16149</b>
EX [1]	53,51 x 43.2 x 9,6	G1 45°			A 442 053 02 32	<b>92-16128</b>
[12]	M 32 x 76 x 20				A 422 050 03 25 A 476 050 00 25	<b>20 1003 44000</b> (1)
	(1) OES specification					
[4]					A 403 050 07 33 A 442 050 03 33	<b>20 1002 25010</b> (2)
[1]					A 403 050 03 33 A 403 050 07 33 A 442 050 03 33	<b>20 1003 40010</b>
[1]					A 403 050 03 33 A 403 050 07 33 A 442 050 03 33 A 442 055 00 20	<b>20 1003 40012</b> (3)
	(2) nur 2-Ventiler/only 2 valves version/seulement 2 soupapes/sólo sistemas de 2 válvulas/заменяемо 2 Клапаны					
	(3) mit Einstellschraube/with adjusting screw/avec vis de réglage/con tornillo de ajuste/c установочным ВИНТОМ					

M

## 402 128

OM 447 Euro 1

**913 - 914**

11.1991 →

D (NA) 6 11967 cm<sup>3</sup> 2V 150-157 kW (204-214 PS) 18:1 155,00 mm

OM 447

**905 - 908, 910 - 912**

11.1986 →

D (NA) 6 11967 cm<sup>3</sup> 2V 150-184 kW (204-250 PS) 155,00 mm

IN [1]	59,0 x 12 x 142,5	A/S - Cr -	- 30° -	-	5 - III	A 403 053 09 01 A 422 050 00 26 A 422 050 02 26 A 422 050 05 26 A 422 053 01 01 A 423 050 00 26 A 442 050 02 26 A 442 050 03 26	<b>16117</b>
IN [1]	59,0 x 12 x 142,5	A/S - Cr -	- 30° -	-	5 - III	A 442 050 05 26	<b>16146</b>
EX [1]	51,0 x 12 x 142,5	A/S - Cr -	- 45° -	-	5 - III	A 422 050 00 27	<b>16116</b>
EX [1]	51,0 x 12 x 142,5	RA/S- Cr -	- 45° -	-	5 - III	A 422 050 01 27 A 422 050 02 27 A 442 050 01 27 A 442 050 02 27 A 442 050 03 27 A 442 050 04 27	<b>16150</b>
[50]	Ø 12 mm					A 422 053 00 26	<b>LK-1610</b>
IN/EX [6]	18,03 x 12 x 67,0	G1				A 403 053 00 30	<b>81-1647</b>
IN/EX [6]	18,03 x 12 x 67,0	G2				A 422 053 04 30	<b>81-16100</b>
IN/EX [6]	18,23 x 12 x 67,0	G1				A 403 053 01 30	<b>81-1648</b>

Fortsetzung nächste Seite / continued on next page / suite page suivante / continuación página próxima / Продолжение на следующей странице



					Reference	Item No.	
	IN [2]	60,11 x 51.2 x 8,4	G1 30°		A 422 053 05 31	<b>92-16151</b>	
	IN [1]	60,11 x 49.3 x 8,4	G1 30°		A 422 053 01 31	<b>92-16150</b>	
					A 447 053 00 31		
	IN [1]	60,31 x 51.2 x 8,6	G1 30°		A 422 053 06 31	<b>92-16152</b>	
	EX [2]	53,11 x 43 x 9,2	G1 45°		A 442 053 00 32	<b>92-16127</b>	
	EX [1]	53,11 x 43 x 9,2	G1 45°		A 422 053 01 32	<b>92-16126</b>	
	EX [1]	53,31 x 43 x 9,4	G1 45°		A 442 053 01 32	<b>92-16149</b>	
	EX [1]	53,51 x 43.2 x 9,6	G1 45°		A 442 053 02 32	<b>92-16128</b>	
	[12]	M 31,5 x 76,5 x 20			A 403 054 09 01	<b>20 1003 40060</b>	
					A 403 054 18 01		
	[12]	M 32 x 76 x 20			A 422 050 03 25	<b>20 1003 44000</b> (1)	
					A 476 050 00 25		
	[12]	M 32 x 76 x 20			A 422 050 03 25	<b>20 1003 44001</b> <span style="border: 1px solid black; padding: 1px;">NEW</span>	
					A 476 050 00 25	(2)	
	(1)	OES specification					
	(2)	IAM specification					
	[4]				A 403 050 07 33	<b>20 1002 25010</b> (3)	
					A 442 050 03 33		
	[1]				A 403 050 03 33	<b>20 1003 40010</b>	
					A 403 050 07 33		
	[1]				A 442 050 03 33		
					A 403 050 03 33	<b>20 1003 40012</b> (4)	
					A 403 050 07 33		
					A 442 050 03 33		
					A 442 055 00 20		
	(3)	nur 2-Ventiler/only 2 valves version/seulement 2 soupapes/sólo sistemas de 2 válvulas/заменяемо 2 Клапаны					
	(4)	mit Einstellschraube/with adjusting screw/avec vis de réglage/con tornillo de ajuste/c установочным винтом					

## 403 128

**OM 447 Euro 1**    **952 - 953**  
03.1991 →    D (A) 6 11967 cm<sup>3</sup> 2V    206 kW    (280 PS) 16,25:1 155,00 mm

**OM 447 Euro 0**    **950 - 951**  
11.1986 →    D (A) 6 11967 cm<sup>3</sup> 2V    206 kW    (280 PS) 16,25:1 155,00 mm

93 990 6..

	IN [1]	59,0 x 12 x 142,5	A/S - Cr -	- 30° -	-	5 - III	A 403 053 09 01	<b>16117</b>
							A 422 050 00 26	
							A 422 050 02 26	
							A 422 050 05 26	
							A 422 053 01 01	
							A 423 050 00 26	
							A 442 050 02 26	
							A 442 050 03 26	
	IN [1]	59,0 x 12 x 142,5	A/S - Cr -	- 30° -	-	5 - III	A 442 050 05 26	<b>16146</b>
	EX [1]	51,0 x 12 x 142,5	RA/S- Cr -	- 45° -	-	5 - III	A 422 050 01 27	<b>16150</b>
							A 422 050 02 27	
							A 442 050 01 27	
							A 442 050 02 27	
							A 442 050 03 27	
							A 442 050 04 27	
	[50]	Ø 12 mm					A 422 053 00 26	<b>LK-1610</b>
	IN/EX [6]	18,03 x 12 x 67,0	G2				A 422 053 04 30	<b>81-16100</b>

Fortsetzung nächste Seite / continued on next page / suite page suivante / continuación página próxima / Продолжение на следующей странице

					Reference	Item No.
IN [1]	60,11 x 49.3 x 8,4	G1 30°			A 422 053 01 31 A 447 053 00 31	<b>92-16150</b>
EX [2]	53,11 x 43 x 9,2	G1 45°			A 442 053 00 32	<b>92-16127</b>
EX [1]	53,11 x 43 x 9,2	G1 45°			A 422 053 01 32	<b>92-16126</b>
EX [1]	53,31 x 43 x 9,4	G1 45°			A 442 053 01 32	<b>92-16149</b>
EX [1]	53,51 x 43.2 x 9,6	G1 45°			A 442 053 02 32	<b>92-16128</b>
[12]	M 31,5 x 76,5 x 20				A 403 054 09 01 A 403 054 18 01	<b>20 1003 40060</b>
[12]	M 32 x 76 x 20				A 422 050 03 25 A 476 050 00 25	<b>20 1003 44000</b> (1)
[12]	M 32 x 76 x 20				A 422 050 03 25 A 476 050 00 25	<b>20 1003 44001</b> <span style="border: 1px solid black; padding: 1px;">NEW</span> (2)
(1)	OES specification					
(2)	IAM specification					
[4]					A 403 050 07 33 A 442 050 03 33	<b>20 1002 25010</b> (3)
[1]					A 403 050 03 33 A 403 050 07 33	<b>20 1003 40010</b>
[1]					A 442 050 03 33 A 403 050 03 33 A 403 050 07 33 A 442 050 03 33 A 442 055 00 20	<b>20 1003 40012</b> (4)
(3)	nur 2-Ventiler/only 2 valves version/seulement 2 soupapes/sólo sistemas de 2 válvulas/заменяемо 2 Клапаны					
(4)	mit Einstellschraube/with adjusting screw/avec vis de réglage/con tornillo de ajuste/c установочным ВИНТОМ					

## 404 128

<b>OM 441 Euro 0</b>	<b>960 - 962, 985</b>								
	12.1988 →	D (LA)	6	10964 cm <sup>3</sup>	2V	243-250 kW	(330-340 PS)	16,25:1	142,00 mm
<b>OM 441</b>	<b>951, 981 - 983</b>								
	01.1989 →	D (LA)	6	10964 cm <sup>3</sup>	2V	243-250 kW	(330-340 PS)	16,25:1	142,00 mm
<b>OM 443 Euro 0</b>	<b>940</b>								
	04.1987 → 02.2001	D (A)	10	18273 cm <sup>3</sup>	2V	340 kW	(462 PS)	16,25:1	142,00 mm
<b>OM 444 Euro 0</b>	<b>901.500</b>								
	05.1988 → 02.1991	D (LA)	12	21927 cm <sup>3</sup>	2V	385-846 kW	(523-1150 PS)	16,25:1	142,00 mm
<b>OM 447 Euro 1</b>	<b>954 - 959</b>								
	09.1991 →	D (A)	6	11967 cm <sup>3</sup>	2V	184 kW	(250 PS)	18:1	155,00 mm
<b>OM 447 Euro 1</b>	<b>980 - 987</b>								
	09.1991 →	D (LA)	6	11967 cm <sup>3</sup>	2V	220 kW	(299-300 PS)	18:1	155,00 mm

90 220 6.., 91 237 6.., 91 630 6.., 94 512 6.., 99 973 6..

IN [1]	59,0 x 12 x 142,5	A/S - Cr -	- 30° -	-	5 - III	A 403 053 09 01 A 422 050 00 26 A 422 050 02 26 A 422 050 05 26 A 422 053 01 01 A 423 050 00 26 A 442 050 02 26 A 442 050 03 26	<b>16117</b>
IN [1]	59,0 x 12 x 142,5	A/S - Cr -	- 30° -	-	5 - III	A 442 050 05 26	<b>16146</b>
EX [1]	51,0 x 12 x 142,5	RA/S- Cr -	- 45° -	-	5 - III	A 422 050 01 27 A 422 050 02 27 A 442 050 01 27 A 442 050 02 27 A 442 050 03 27 A 442 050 04 27	<b>16150</b>
[50]	∅ 12 mm					A 422 053 00 26	<b>LK-1610</b>
Fortsetzung nächste Seite / continued on next page / suite page suivante / continuación página próxima / Продолжение на следующей странице							

					Reference	Item No.
IN/EX [6]	18,03 x 12 x 67,0	G2			A 422 053 04 30	81-16100
IN [2]	60,11 x 51.2 x 8,4	G1 30°			A 422 053 05 31	92-16151
IN [1]	60,31 x 51.2 x 8,6	G1 30°			A 422 053 06 31	92-16152
EX [2]	53,11 x 43 x 9,2	G1 45°			A 422 053 00 32	92-16127
EX [1]	53,11 x 43 x 9,2	G1 45°			A 422 053 01 32	92-16126
EX [1]	53,31 x 43 x 9,4	G1 45°			A 442 053 01 32	92-16149
EX [1]	53,51 x 43.2 x 9,6	G1 45°			A 442 053 02 32	92-16128
[12]	M 31,5 x 76,5 x 20				A 403 054 09 01 A 403 054 18 01	20 1003 40060
[12]	M 32 x 76 x 20				A 422 050 03 25 A 476 050 00 25	20 1003 44000 (1)
[12]	M 32 x 76 x 20				A 422 050 03 25 A 476 050 00 25	20 1003 44001 <b>NEW</b> (2)
	(1) OES specification					
	(2) IAM specification					
[4]					A 403 050 07 33 A 442 050 03 33	20 1002 25010 (3)
[1]					A 403 050 03 33 A 403 050 07 33 A 442 050 03 33	20 1003 40010
[1]					A 403 050 03 33 A 403 050 07 33 A 442 050 03 33 A 442 055 00 20	20 1003 40012 (4)
	(3) nur 2-Ventiler/only 2 valves version/seulement 2 soupapes/sólo sistemas de 2 válvulas/заменяемо 2 Клапаны					
	(4) mit Einstellschraube/with adjusting screw/avec vis de réglage/con tornillo de ajuste/c установочным винтом					
	- - G - S -	- - -			A 402 010 03 20 A 403 010 40 20 A 403 010 89 20 A 427 010 00 20 A 427 010 10 20 A 429 010 02 20 A 442 010 07 20	20 0803 40300
	- V - G - S -	- - -	ready-to-install		A 427 010 10 20	20 0803 40301

**405** **128**

OM 442 Euro 0

969-502 (USA), 969-503 (USA), 969-504 (USA)

07.1987 →

D (LA)

8

14618 cm<sup>3</sup>

2V

261-298 kW

(350-400 PS)

16,25:1 142,00 mm

90 220 6.., 91 630 6..

Fortsetzung nächste Seite / continued on next page / suite page suivante / continuación página próxima / Продолжение на следующей странице

					Reference	Item No.
	IN [1] 59,0 x 12 x 142,5	A/S - Cr -	- 30° - -	5 - III	A 403 053 09 01 A 422 050 00 26 A 422 050 02 26 A 422 050 05 26 A 422 053 01 01 A 423 050 00 26 A 442 050 02 26 A 442 050 03 26	<b>16117</b>
	IN [1] EX [1] 59,0 x 12 x 142,5 51,0 x 12 x 142,5	A/S - Cr - RA/S- Cr -	- 30° - - - 45° - -	5 - III 5 - III	A 442 050 05 26 A 422 050 01 27 A 422 050 02 27 A 442 050 01 27 A 442 050 02 27 A 442 050 03 27 A 442 050 04 27	<b>16146</b> <b>16150</b>
	[50] Ø 12 mm				A 422 053 00 26	<b>LK-1610</b>
	IN/EX [6] IN/EX [6] IN/EX [6] 18,03 x 12 x 67,0 18,03 x 12 x 67,0 18,23 x 12 x 67,0	G1 G2 G1			A 403 053 00 30 A 422 053 04 30 A 403 053 01 30	<b>81-1647</b> <b>81-16100</b> <b>81-1648</b>
	IN [2] IN [1] EX [2] EX [1] EX [1] EX [1] 60,11 x 51.2 x 8,4 60,31 x 51.2 x 8,6 53,11 x 43 x 9,2 53,11 x 43 x 9,2 53,31 x 43 x 9,4 53,51 x 43.2 x 9,6	G1 30° G1 30° G1 45° G1 45° G1 45° G1 45°			A 422 053 05 31 A 422 053 06 31 A 442 053 00 32 A 422 053 01 32 A 442 053 01 32 A 442 053 02 32	<b>92-16151</b> <b>92-16152</b> <b>92-16127</b> <b>92-16126</b> <b>92-16149</b> <b>92-16128</b>
	724 mm				A 422 050 00 01 A 422 050 04 01 A 422 050 10 01 A 422 050 22 01	<b>20 1003 42201</b>
	[1] [1]				A 403 050 03 33 A 403 050 07 33 A 442 050 03 33 A 403 050 03 33 A 403 050 07 33 A 442 050 03 33 A 442 055 00 20	<b>20 1003 40010</b> <b>20 1003 40012 (1)</b>
	(1) mit Einstellschraube/with adjusting screw/avec vis de réglage/con tornillo de ajuste/с установочным винтом					
	- - G - S -	- - -			A 402 010 03 20 A 403 010 40 20 A 403 010 89 20 A 427 010 00 20 A 427 010 10 20 A 429 010 02 20 A 442 010 07 20	<b>20 0803 40300</b>
	- V - G - S -	- - -	ready-to-install		A 427 010 10 20	<b>20 0803 40301</b>

M

					Reference	Item No.	
<b>406</b>		<b>128</b>	<b>OM 447 969-501 (USA), 969-502 (USA), 969-503 (USA)</b> 07.1987 → D (LA) 6 11970 cm <sup>3</sup> 2V 224-261 kW (300-350 PS) 155,00 mm				
	IN [1]	59,0 x 12 x 142,5	A/S - Cr -	- 30° -	- 5 - III	A 403 053 09 01 A 422 050 00 26 A 422 050 02 26 A 422 050 05 26 A 422 053 01 01 A 423 050 00 26 A 442 050 02 26 A 442 050 03 26	<b>16117</b>
	IN [1]	59,0 x 12 x 142,5	A/S - Cr -	- 30° -	- 5 - III	A 442 050 05 26	<b>16146</b>
	EX [1]	51,0 x 12 x 142,5	RA/S- Cr -	- 45° -	- 5 - III	A 422 050 01 27 A 422 050 02 27 A 442 050 01 27 A 442 050 02 27 A 442 050 03 27 A 442 050 04 27	<b>16150</b>
	[50]	Ø 12 mm				A 422 053 00 26	<b>LK-1610</b>
	IN/EX [6]	18,03 x 12 x 67,0	G1			A 403 053 00 30	<b>81-1647</b>
	IN/EX [6]	18,23 x 12 x 67,0	G1			A 403 053 01 30	<b>81-1648</b>
	IN [1]	60,11 x 49.3 x 8,4	G1 30°			A 422 053 01 31 A 447 053 00 31	<b>92-16150</b>
	EX [2]	53,11 x 43 x 9,2	G1 45°			A 442 053 00 32	<b>92-16127</b>
	EX [1]	53,11 x 43 x 9,2	G1 45°			A 422 053 01 32	<b>92-16126</b>
	EX [1]	53,31 x 43 x 9,4	G1 45°			A 442 053 01 32	<b>92-16149</b>
	EX [1]	53,51 x 43.2 x 9,6	G1 45°			A 442 053 02 32	<b>92-16128</b>
	[1]					A 403 050 03 33 A 403 050 07 33 A 442 050 03 33	<b>20 1003 40010</b>
	[1]					A 403 050 03 33 A 403 050 07 33 A 442 050 03 33 A 442 055 00 20	<b>20 1003 40012 (1)</b>
						(1) mit Einstellschraube/with adjusting screw/avec vis de réglage/con tornillo de ajuste/c установочным винтом	
<b>407</b>		<b>128</b>	<b>OM 462 Euro 0 900-511 (AFS)</b> 07.1987 → D (LA) 8 14618 cm <sup>3</sup> 2V 329 kW (447 PS) 16,25 142,00 mm				
<b>OM 462 Euro 0</b>	<b>900-411 (AFS), 900-414</b> 12.1991 → D (A) 8 14618 cm <sup>3</sup> 2V 269 kW (366 PS) 16,25 142,00 mm						
90 220 6..., 91 630 6..							
	IN [1]	59,0 x 12 x 142,5	A/S - Cr -	- 30° -	- 5 - III	A 403 053 09 01 A 422 050 00 26 A 422 050 02 26 A 422 050 05 26 A 422 053 01 01 A 423 050 00 26 A 442 050 02 26 A 442 050 03 26	<b>16117</b>
	IN [1]	59,0 x 12 x 142,5	A/S - Cr -	- 30° -	- 5 - III	A 442 050 05 26	<b>16146</b>
	EX [1]	51,0 x 12 x 142,5	RA/S- Cr -	- 45° -	- 5 - III	A 422 050 01 27 A 422 050 02 27 A 442 050 01 27 A 442 050 02 27 A 442 050 03 27 A 442 050 04 27	<b>16150</b>
Fortsetzung nächste Seite / continued on next page / suite page suivante / continuación página próxima / Продолжение на следующей странице							

M



					Reference	Item No.
[50]	Ø 12 mm				A 422 053 00 26	LK-1610
IN/EX [6]	18,03 x 12 x 67,0	G2			A 422 053 04 30	81-16100
IN [2]	60,11 x 51.2 x 8,4	G1 45°			A 442 053 05 31	92-16122
IN [1]	60,51 x 51.2 x 8,9	G1 30°			A 442 053 07 31	92-16123
EX [2]	53,11 x 43 x 9,2	G1 45°			A 442 053 00 32	92-16127
EX [1]	53,11 x 43 x 9,2	G1 45°			A 422 053 01 32	92-16126
EX [1]	53,31 x 43 x 9,4	G1 45°			A 442 053 01 32	92-16149
EX [1]	53,51 x 43.2 x 9,6	G1 45°			A 442 053 02 32	92-16128
[1]					A 403 050 03 33 A 403 050 07 33 A 442 050 03 33	20 1003 40010
[1]					A 403 050 03 33 A 403 050 07 33 A 442 050 03 33 A 442 055 00 20	20 1003 40012 (1)
	(1) mit Einstellschraube/with adjusting screw/avec vis de réglage/con tornillo de ajuste/с установочным винтом					

## 408

## 128

OM 355

975-005 (AFS), 975-006 (AFS)

12.1987 → 09.1996 D

6 11581 cm<sup>3</sup> 4V

176 kW

(240 PS) 17,2:1 150,00 mm

93 568 6..

IN [2]	42,0 x 9 x 129,8	S - Cr -	- 45° - -	5 - III	A 345 053 71 01 A 346 053 00 01 A 346 053 01 01 A 346 053 03 01	1657
EX [2]	37,0 x 9 x 165,3	A/S - Cr -	- 45° - -	5 - III	A 345 053 71 05 A 346 053 01 05 A 346 053 02 05 A 355 050 01 27	1658
IN [6]	15,04 x 9 x 68,5	G1			A 346 053 09 29	81-1640
IN [4]	15,20 x 9 x 67,5	G1			A 346 053 11 29	81-1642
EX [6]	15,00 x 9 x 86,5	G1			A 355 053 03 30	81-1641
IN [2]	51,06 x 37 x 7,5	G1 45°			A 346 053 07 31 A 355 053 11 31	92-16106
IN [1]	51,26 x 37 x 7,5	G1 45°			A 346 053 08 31	92-16140
IN [1]	51,46 x 37 x 7,5	G1 45°			A 355 053 09 31 A 355 053 13 31	92-16142
EX [2]	40,10 x 31 x 7,5	G1 45°			A 345 053 01 32 A 346 053 05 32 A 355 053 06 32 A 355 053 10 32 A 355 053 18 32	92-16110
EX [1]	40,46 x 31 x 7,5	G1 45°			A 355 053 12 32 A 355 053 20 32	92-16143

## 409

## 128

OM 444 Euro 0

901-410

05.1988 → 02.1991 D (LA) 12 21920 cm<sup>3</sup> 2V

142,00 mm

90 220 6.., 91 630 6.., 94 512 6.., 99 973 6..

IN [1]	59,0 x 12 x 142,5	A/S - Cr -	- 30° - -	5 - III	A 442 050 05 26	16146
EX [1]	51,0 x 12 x 142,5	RA/S- Cr -	- 45° - -	5 - III	A 422 050 01 27 A 422 050 02 27 A 442 050 01 27 A 442 050 02 27 A 442 050 03 27 A 442 050 04 27	16150

Fortsetzung nächste Seite / continued on next page / suite page suivante / continuación página próxima / Продолжение на следующей странице

					Reference	Item No.
[50]	Ø 12 mm				A 422 053 00 26	LK-1610
IN/EX [6]	18,03 x 12 x 67,0	G1			A 403 053 00 30	81-1647
	- - G - S -	- - - -			A 402 010 03 20 A 403 010 40 20 A 403 010 89 20 A 427 010 00 20 A 427 010 10 20 A 429 010 02 20 A 442 010 07 20	20 0803 40300
		- V - G - S -	- - - -	ready-to-install	A 427 010 10 20	20 0803 40301

## 410 128

**OM 444 Euro 0**    **901.504, 901.505, 901.506**  
 05.1988 →    D (LA) 12    21927 cm<sup>3</sup> 2V    385-846 kW (523-1150 PS) 16,25:1 142,00 mm  
 90 220 6.., 91 630 6.., 94 512 6.., 99 973 6..

IN [1] EX [1]	59,0 x 12 x 142,5 51,0 x 12 x 142,5	A/S - Cr - RA/S- Cr -	- 30° - - - 45° - -	5 - III 5 - III	A 442 050 05 26 A 422 050 01 27 A 422 050 02 27 A 442 050 01 27 A 442 050 02 27 A 442 050 03 27 A 442 050 04 27	16146 16150
IN/EX [6]	18,03 x 12 x 67,0	G2			A 422 053 04 30	81-16100
IN [2] EX [2]	60,11 x 51.2 x 8,4 53,11 x 43 x 9,2	G1 30° G1 45°			A 422 053 05 31 A 442 053 00 32	92-16151 92-16127

Fortsetzung nächste Seite / continued on next page / suite page suivante / continuación página próxima / Продолжение на следующей странице

					Reference	Item No.
	- - G - S -	- - -			A 402 010 03 20 A 403 010 40 20 A 403 010 89 20 A 427 010 00 20 A 427 010 10 20 A 429 010 02 20 A 442 010 07 20	<b>20 0803 40300</b>
		- - -	ready-to-install		A 427 010 10 20	<b>20 0803 40301</b>
		- - -				

## 411 128

OM 442

985

07.1988 → 09.1996 D (LA) 8 14618 cm<sup>3</sup> 2V 320-362 kW (435-492 PS) 142,00 mm

	IN [1]	59,0 x 12 x 142,5	A/S - Cr -	- 30° - -	5 - III	A 403 053 09 01 A 422 050 00 26 A 422 050 02 26 A 422 050 05 26 A 422 053 01 01 A 423 050 00 26 A 442 050 02 26 A 442 050 03 26	<b>16117</b>
	EX [1]	51,0 x 12 x 142,5	RA/S- Cr -	- 45° - -	5 - III	A 422 050 01 27 A 422 050 02 27 A 442 050 01 27 A 442 050 02 27 A 442 050 03 27 A 442 050 04 27	<b>16150</b>
	IN/EX [6]	18,03 x 12 x 67,0	G2			A 422 053 04 30	<b>81-16100</b>
	IN [1]	60,11 x 49.3 x 8,4	G1 30°			A 422 053 01 31 A 447 053 00 31	<b>92-16150</b>
	EX [2]	53,11 x 43 x 9,2	G1 45°			A 442 053 00 32	<b>92-16127</b>
	EX [1]	53,11 x 43 x 9,2	G1 45°			A 422 053 01 32	<b>92-16126</b>
	EX [1]	53,31 x 43 x 9,4	G1 45°			A 442 053 01 32	<b>92-16149</b>
	EX [1]	53,51 x 43.2 x 9,6	G1 45°			A 442 053 02 32	<b>92-16128</b>

## 412 128

OM 440 Euro 1

970, 972 - 973, 978 - 979, 981 - 983

07.1988 → D (LA) 8 14618 cm<sup>3</sup> 2V 320-370 kW (435-503 PS) 16,75:1 142,00 mm

OM 440 Euro 1

940 - 942

07.1991 → 08.1994 D (A) 8 14618 cm<sup>3</sup> 2V 250 kW (340 PS) 18:1 142,00 mm

OM 442 Euro 1

997 - 998

07.1988 → 09.1996 D (LA) 8 14618 cm<sup>3</sup> 2V 370 kW (503 PS) 16,75:1 142,00 mm

OM 442 Euro 1

977 - 978

05.1989 → 08.1994 D (A) 8 14618 cm<sup>3</sup> 2V 250 kW (340 PS) 18:1 142,00 mm

94 331 7..

Fortsetzung nächste Seite / continued on next page / suite page suivante / continuación página próxima / Продолжение на следующей странице

					Reference	Item No.
IN [1]	59,0 x 12 x 142,5	A/S - Cr -	- 30° - -	5 - III	A 403 053 09 01 A 422 050 00 26 A 422 050 02 26 A 422 050 05 26 A 422 053 01 01 A 423 050 00 26 A 442 050 02 26 A 442 050 03 26	<b>16117</b>
IN [1] EX [1]	59,0 x 12 x 142,5 51,0 x 12 x 142,5	A/S - Cr - RA/S- Cr -	- 30° - - - 45° - -	5 - III 5 - III	A 442 050 05 26 A 422 050 01 27 A 422 050 02 27 A 442 050 01 27 A 442 050 02 27 A 442 050 03 27 A 442 050 04 27	<b>16146</b> <b>16150</b>
[50]	Ø 12 mm				A 422 053 00 26	<b>LK-1610</b>
IN/EX [6]	18,03 x 12 x 67,0	G2			A 422 053 04 30	<b>81-16100</b>
IN [2] IN [1] EX [2] EX [1] EX [1] EX [1]	60,11 x 51.2 x 8,4 60,31 x 51.2 x 8,6 53,11 x 43 x 9,2 53,11 x 43 x 9,2 53,31 x 43 x 9,4 53,51 x 43.2 x 9,6	G1 30° G1 30° G1 45° G1 45° G1 45° G1 45°			A 422 053 05 31 A 422 053 06 31 A 442 053 00 32 A 422 053 01 32 A 442 053 01 32 A 442 053 02 32	<b>92-16151</b> <b>92-16152</b> <b>92-16127</b> <b>92-16126</b> <b>92-16149</b> <b>92-16128</b>
	724 mm				A 402 050 21 01 A 402 050 25 01 A 442 050 17 01	<b>20 1003 40201</b>
[12]	M 31,5 x 76,5 x 20				A 403 054 09 01 A 403 054 18 01	<b>20 1003 40060</b>
[12]	M 32 x 76 x 20				A 422 050 03 25 A 476 050 00 25	<b>20 1003 44000</b> (1)
[12]	M 32 x 76 x 20				A 422 050 03 25 A 476 050 00 25	<b>20 1003 44001</b> (2)
(1) OES specification (2) IAM specification						
[4] [1] [1]					A 403 050 07 33 A 442 050 03 33 A 403 050 03 33 A 403 050 07 33 A 442 050 03 33 A 403 050 03 33 A 403 050 07 33 A 442 050 03 33 A 442 055 00 20	<b>20 1002 25010</b> (3) <b>20 1003 40010</b> <b>20 1003 40012</b> (4)
(3) nur 2-Ventiler/only 2 valves version/seulement 2 soupapes/sólo sistemas de 2 válvulas/заменяемо 2 Клапаны (4) mit Einstellschraube/with adjusting screw/avec vis de réglage/con tornillo de ajuste/c установочным винтом						
Fortsetzung nächste Seite / continued on next page / suite page suivante / continuación página próxima / Продолжение на следующей странице						

					Reference	Item No.
	- V - G - S -	- - - EVB	ready-to-install		A 442 010 06 20	20 0803 44000
		- - G - S -			A 442 010 06 20	20 0803 44010

## 413 128

OM 440 Euro 1

971, 975 - 976  
07.1988 →

D (LA) 8 14618 cm<sup>3</sup> 2V 370 kW (503 PS) 16,75:1 142,00 mm

94 331 7..

	IN [1]	59,0 x 12 x 142,5	A/S - Cr -	- 30° - -	5 - III	A 403 053 09 01 A 422 050 00 26 A 422 050 02 26 A 422 050 05 26 A 422 053 01 01 A 423 050 00 26 A 442 050 02 26 A 442 050 03 26	16117	
	IN [1]	59,0 x 12 x 142,5	A/S - Cr -	- 30° - -	5 - III	A 442 050 05 26	16146	
	EX [2]	17,0 x 8 x 84,1	A - -	- 45° - -	1 -	A 442 016 01 91	50 004 664 (1)	
	EX [2]	17,1 x 8 x 90,3	A - -	- 45° - -	1 -	A 442 016 02 91 A 442 016 03 91	50 004 665 (2)	
	EX [1]	51,0 x 12 x 142,5	RA/S- Cr -	- 45° - -	5 - III	A 422 050 01 27 A 422 050 02 27 A 442 050 01 27 A 442 050 02 27 A 442 050 03 27 A 442 050 04 27	16150	
	(1)	Konstantdrosselventil - flach Exhaust brake valve - flat Soupape de réduction permanente - plate Válvula de reducción permanente - plana Постоянный дроссельный клапан						
	(2)	Konstantdrosselventil - Dom Exhaust brake valve - dome Papillon constant - Dôme Válvula de estrangulamiento constante - Dom Нерегулируемый дроссельный клапан - собор						
	[50]	Ø 12 mm				A 422 053 00 26	LK-1610	
	IN/EX [6]	18,03 x 12 x 67,0	G2			A 422 053 04 30	81-16100	
	IN [2]	60,11 x 51.2 x 8,4	G1 45°			A 442 053 05 31	92-16122	
	IN [1]	60,51 x 51.2 x 8,9	G1 30°			A 442 053 07 31	92-16123	
	EX [2]	53,11 x 43 x 9,2	G1 45°			A 442 053 00 32	92-16127	
	EX [1]	53,11 x 43 x 9,2	G1 45°			A 422 053 01 32	92-16126	
	EX [1]	53,31 x 43 x 9,4	G1 45°			A 442 053 01 32	92-16149	
	EX [1]	53,51 x 43.2 x 9,6	G1 45°			A 442 053 02 32	92-16128	
Fortsetzung nächste Seite / continued on next page / suite page suivante / continuación página próxima / Продолжение на следующей странице								



					Reference	Item No.
[12]	M 31,5 x 76,5 x 20				A 403 054 09 01 A 403 054 18 01	<b>20 1003 40060</b>
[12]	M 32 x 76 x 20				A 422 050 03 25 A 476 050 00 25	<b>20 1003 44000</b> (3)
[12]	M 32 x 76 x 20				A 422 050 03 25 A 476 050 00 25	<b>20 1003 44001</b> <b>NEW</b> (4)
(3)	OES specification					
(4)	IAM specification					
[4]					A 403 050 07 33 A 442 050 03 33	<b>20 1002 25010</b> (5)
[1]					A 403 050 03 33 A 403 050 07 33 A 442 050 03 33	<b>20 1003 40010</b>
[1]					A 403 050 03 33 A 403 050 07 33 A 442 050 03 33 A 442 055 00 20	<b>20 1003 40012</b> (6)
(5)	nur 2-Ventiler/only 2 valves version/seulement 2 soupapes/sólo sistemas de 2 válvulas/заменяемо 2 Клапаны					
(6)	mit Einstellschraube/with adjusting screw/avec vis de réglage/con tornillo de ajuste/c установочным винтом					
	- V - G - S -	- - - EVB	ready-to-install		A 442 010 06 20	<b>20 0803 44000</b>
	- - G - S -	- - -			A 442 010 06 20	<b>20 0803 44010</b>

**M**
**414** **128**

**OM 442 Euro 0**    **993 - 994**  
 07.1988 → 09.1996 D (LA) 8 14618 cm<sup>3</sup> 2V    362 kW    (492 PS) 16,25:1 142,00 mm  
 90 220 6.., 91 630 6.., 94 512 6.., 99 973 6..

IN [1]	59,0 x 12 x 142,5	A/S - Cr -	- 30° - -	5 - III	A 403 053 09 01 A 422 050 00 26 A 422 050 02 26 A 422 050 05 26 A 422 053 01 01 A 423 050 00 26 A 442 050 02 26 A 442 050 03 26	<b>16117</b>
IN [1]	59,0 x 12 x 142,5	A/S - Cr -	- 30° - -	5 - III	A 442 050 05 26	<b>16146</b>
EX [2]	17,0 x 8 x 84,1	A - -	- 45° - -	1 -	A 442 016 01 91	<b>50 004 664</b> (1)
EX [2]	17,1 x 8 x 90,3	A - -	- 45° - -	1 -	A 442 016 02 91 A 442 016 03 91	<b>50 004 665</b> (2)
EX [1]	51,0 x 12 x 142,5	RA/S- Cr -	- 45° - -	5 - III	A 422 050 01 27 A 422 050 02 27 A 442 050 01 27 A 442 050 02 27 A 442 050 03 27 A 442 050 04 27	<b>16150</b>

Fortsetzung nächste Seite / continued on next page / suite page suivante / continuación página próxima / Продолжение на следующей странице

					Reference	Item No.
(1)	Konstantdrosselventil - flach Exhaust brake valve - flat Soupape de réduction permanente - plate Válvula de reducción permanente - plana Постоянный дроссельный клапан					
(2)	Konstantdrosselventil - Dom Exhaust brake valve - dome Papillon constant - Dôme Válvula de estrangulamiento constante - Dom Нерегулируемый дроссельный клапан - собор					
[50]	Ø 12 mm				A 422 053 00 26	<b>LK-1610</b>
IN/EX [6]	18,03 x 12 x 67,0	G2			A 422 053 04 30	<b>81-16100</b>
IN [2] IN [1] EX [2] EX [1] EX [1] EX [1]	60,11 x 51.2 x 8,4 60,51 x 51.2 x 8,9 53,11 x 43 x 9,2 53,11 x 43 x 9,2 53,31 x 43 x 9,4 53,51 x 43.2 x 9,6	G1 45° G1 30° G1 45° G1 45° G1 45° G1 45°			A 442 053 05 31 A 442 053 07 31 A 442 053 00 32 A 422 053 01 32 A 442 053 01 32 A 442 053 02 32	<b>92-16122</b> <b>92-16123</b> <b>92-16127</b> <b>92-16126</b> <b>92-16149</b> <b>92-16128</b>
	724 mm				A 422 050 00 01 A 422 050 04 01 A 422 050 10 01 A 422 050 22 01	<b>20 1003 42201</b>
[12]	M 31,5 x 76,5 x 20				A 403 054 09 01 A 403 054 18 01	<b>20 1003 40060</b>
[12]	M 32 x 76 x 20				A 422 050 03 25 A 476 050 00 25	<b>20 1003 44000</b> (3)
[12]	M 32 x 76 x 20				A 422 050 03 25 A 476 050 00 25	<b>20 1003 44001</b> <b>NEW</b> (4)
(3)	OES specification					
(4)	IAM specification					
[4] [1] [1]					A 403 050 07 33 A 442 050 03 33 A 403 050 03 33 A 403 050 07 33 A 442 050 03 33 A 403 050 03 33 A 403 050 07 33 A 442 050 03 33 A 442 055 00 20	<b>20 1002 25010</b> (5) <b>20 1003 40010</b> <b>20 1003 40012</b> (6)
(5)	nur 2-Ventiler/only 2 valves version/seulement 2 soupapes/sólo sistemas de 2 válvulas/заменяемо 2 Клапаны					
(6)	mit Einstellschraube/with adjusting screw/avec vis de réglage/con tornillo de ajuste/c установочным ВИНТОМ					

## 415 128

<b>OM 443 Euro 0</b>	<b>980</b>								
	1989 → 02.2001	D (LA)	10	18273 cm <sup>3</sup>	2V	412 kW	(560 PS)	16,25:1	142,00 mm
<b>OM 447 Euro 1</b>	<b>995</b>								
		D (A)	6	11967 cm <sup>3</sup>	2V	184 kW	(250 PS)	18:1	155,00 mm

90 220 6.., 91 237 6.., 91 630 6.., 94 512 6.., 99 973 6..

Fortsetzung nächste Seite / continued on next page / suite page suivante / continuación página próxima / Продолжение на следующей странице

					Reference	Item No.
IN [1]	59,0 x 12 x 142,5	A/S - Cr -	- 30° - -	5 - III	A 403 053 09 01 A 422 050 00 26 A 422 050 02 26 A 422 050 05 26 A 422 053 01 01 A 423 050 00 26 A 442 050 02 26 A 442 050 03 26	<b>16117</b>
IN [1] EX [1]	59,0 x 12 x 142,5 51,0 x 12 x 142,5	A/S - Cr - RA/S- Cr -	- 30° - - - 45° - -	5 - III 5 - III	A 442 050 05 26 A 422 050 01 27 A 422 050 02 27 A 442 050 01 27 A 442 050 02 27 A 442 050 03 27 A 442 050 04 27	<b>16146</b> <b>16150</b>
[50]	Ø 12 mm				A 422 053 00 26	<b>LK-1610</b>
IN/EX [6]	18,03 x 12 x 67,0	G2			A 422 053 04 30	<b>81-16100</b>
IN [2] IN [1] EX [2] EX [1] EX [1] EX [1]	60,11 x 51.2 x 8,4 60,31 x 51.2 x 8,6 53,11 x 43 x 9,2 53,11 x 43 x 9,2 53,31 x 43 x 9,4 53,51 x 43.2 x 9,6	G1 30° G1 30° G1 45° G1 45° G1 45° G1 45°			A 422 053 05 31 A 422 053 06 31 A 442 053 00 32 A 422 053 01 32 A 442 053 01 32 A 442 053 02 32	<b>92-16151</b> <b>92-16152</b> <b>92-16127</b> <b>92-16126</b> <b>92-16149</b> <b>92-16128</b>
[12]	M 32 x 76 x 20				A 422 050 03 25 A 476 050 00 25	<b>20 1003 44000</b> (1)
[12]	M 32 x 76 x 20				A 422 050 03 25 A 476 050 00 25	<b>20 1003 44001</b> <b>NEW</b> (2)
	(1) OES specification (2) IAM specification					
[4] [1] [1]					A 403 050 07 33 A 442 050 03 33 A 403 050 03 33 A 403 050 07 33 A 442 050 03 33 A 403 050 03 33 A 403 050 07 33 A 442 050 03 33 A 442 055 00 20	<b>20 1002 25010</b> (3) <b>20 1003 40010</b> <b>20 1003 40012</b> (4)
	(3) nur 2-Ventiler/only 2 valves version/seulement 2 soupapes/sólo sistemas de 2 válvulas/заменяемо 2 Клапаны (4) mit Einstellschraube/with adjusting screw/avec vis de réglage/con tornillo de ajuste/c установочным винтом					
Fortsetzung nächste Seite / continued on next page / suite page suivante / continuación página próxima / Продолжение на следующей странице						

					Reference	Item No.
	- - G - S -	- - -			A 402 010 03 20 A 403 010 40 20 A 403 010 89 20 A 427 010 00 20 A 427 010 10 20 A 429 010 02 20 A 442 010 07 20	<b>20 0803 40300</b>
	- V - G - S -	- - -	ready-to-install		A 427 010 10 20	<b>20 0803 40301</b>

## 416 128

<b>OM 443 Euro 0</b>	<b>901-500</b>	08.1989 → 03.1991	D (LA)	10	18273 cm <sup>3</sup>	2V	142,00 mm
<b>OM 443 Euro 1</b>	<b>901-504</b>	07.1995 →	D (LA)	10	18273 cm <sup>3</sup>	2V	142,00 mm

90 220 6., 91 630 6., 94 331 7., 94 512 6., 99 973 6.

	IN [1]	59,0 x 12 x 142,5	A/S - Cr -	- 30° - -	5 - III	A 403 053 09 01 A 422 050 00 26 A 422 050 02 26 A 422 050 05 26 A 422 053 01 01 A 423 050 00 26 A 442 050 02 26 A 442 050 03 26	<b>16117</b>
	IN [1]	59,0 x 12 x 142,5	A/S - Cr -	- 30° - -	5 - III	A 442 050 05 26	<b>16146</b>
	EX [1]	51,0 x 12 x 142,5	RA/S- Cr -	- 45° - -	5 - III	A 422 050 01 27 A 422 050 02 27 A 442 050 01 27 A 442 050 02 27 A 442 050 03 27 A 442 050 04 27	<b>16150</b>
	[50]	∅ 12 mm				A 422 053 00 26	<b>LK-1610</b>
	IN/EX [6]	18,03 x 12 x 67,0	G2			A 422 053 04 30	<b>81-16100</b>
	IN [2]	60,11 x 51.2 x 8,4	G1 30°			A 422 053 05 31	<b>92-16151</b>
	IN [1]	60,31 x 51.2 x 8,6	G1 30°			A 422 053 06 31	<b>92-16152</b>
	EX [2]	53,11 x 43 x 9,2	G1 45°			A 442 053 00 32	<b>92-16127</b>
	EX [1]	53,11 x 43 x 9,2	G1 45°			A 422 053 01 32	<b>92-16126</b>
	EX [1]	53,31 x 43 x 9,4	G1 45°			A 442 053 01 32	<b>92-16149</b>
	EX [1]	53,51 x 43.2 x 9,6	G1 45°			A 442 053 02 32	<b>92-16128</b>
	[12]	M 32 x 76 x 20				A 422 050 03 25 A 476 050 00 25	<b>20 1003 44000 (1)</b>
	[12]	M 32 x 76 x 20				A 422 050 03 25 A 476 050 00 25	<b>20 1003 44001 <span style="border: 1px solid black; padding: 1px;">NEW</span> (2)</b>
	(1)	OES specification					
	(2)	IAM specification					

					Reference	Item No.	
<b>417</b>		<b>128</b>					
<b>OM 475</b>	<b>982</b>	D (LA) 5	9973 cm <sup>3</sup> 2V	221 kW	(300 PS) 16,25:1	155,00 mm	
<b>OM 475 Euro 1</b>	<b>984 - 986, 989, 991, 997 - 998</b>	D (LA) 5	9973 cm <sup>3</sup> 2V	184-224 kW	(250-305 PS) 16,25:1	155,00 mm	
<b>OM 475</b>	<b>974, 976, 978</b>	D (A) 5	9973 cm <sup>3</sup> 2V	205-235 kW	(279-320 PS) 16,25:1	155,00 mm	
	10.1998 →						
<b>OM 476 Euro 1</b>	<b>985</b>	D (LA) 6	11967 cm <sup>3</sup> 2V	261 kW	(355 PS) 16,6:1	155,00 mm	
	01.1991 →						
<b>OM 489 Euro 1</b>	<b>960 - 961</b>	D (LA) 5	9973 cm <sup>3</sup> 2V	155-184 kW	(211-250 PS)	155,00 mm	
	05.1990 →						
40 111 6.., 91 467 6..							
	IN [1]	59,0 x 12 x 142,5	A/S - Cr -	- 30° - -	5 - III	A 403 053 09 01 A 422 050 00 26 A 422 050 02 26 A 422 050 05 26 A 422 053 01 01 A 423 050 00 26 A 442 050 02 26 A 442 050 03 26	<b>16117</b>
	IN [1]	59,0 x 12 x 142,5	A/S - Cr -	- 30° - -	5 - III	A 442 050 05 26	<b>16146</b>
	EX [2]	17,1 x 8 x 90,3	A - - -	- 45° - -	1 -	A 442 016 02 91 A 442 016 03 91	<b>50 004 665</b> (1)
	EX [1]	51,0 x 12 x 142,5	RA/S- Cr -	- 45° - -	5 - III	A 422 050 01 27 A 422 050 02 27 A 442 050 01 27 A 442 050 02 27 A 442 050 03 27 A 442 050 04 27	<b>16150</b>
	(1)	Konstantdrosselventil - Dom Exhaust brake valve - dome Papillon constant - Dôme Válvula de estrangulamiento constante - Dom Нерегулируемый дроссельный клапан - собор					
	[50]	Ø 12 mm				A 422 053 00 26	<b>LK-1610</b>
	IN/EX [6]	18,03 x 12 x 67,0	G2			A 422 053 04 30	<b>81-16100</b>
	IN [1]	60,11 x 49.3 x 8,4	G1 30°			A 422 053 01 31 A 447 053 00 31	<b>92-16150</b>
	EX [2]	53,11 x 43 x 9,2	G1 45°			A 442 053 00 32	<b>92-16127</b>
	EX [1]	53,11 x 43 x 9,2	G1 45°			A 422 053 01 32	<b>92-16126</b>
	EX [1]	53,31 x 43 x 9,4	G1 45°			A 442 053 01 32	<b>92-16149</b>
	EX [1]	53,51 x 43.2 x 9,6	G1 45°			A 442 053 02 32	<b>92-16128</b>
	[12]	M 32 x 76 x 20				A 422 050 03 25 A 476 050 00 25	<b>20 1003 44000</b> (2)
	(2)	OES specification					
	[4]					A 403 050 07 33 A 442 050 03 33	<b>20 1002 25010</b> (3)
	[1]					A 403 050 03 33 A 403 050 07 33 A 442 050 03 33	<b>20 1003 40010</b>
	[1]					A 403 050 03 33 A 403 050 07 33 A 442 050 03 33 A 442 055 00 20	<b>20 1003 40012</b> (4)
	(3)	nur 2-Ventiler/only 2 valves version/seulement 2 soupapes/sólo sistemas de 2 válvulas/заменяемо 2 Клапаны					
	(4)	mit Einstellschraube/with adjusting screw/avec vis de réglage/con tornillo de ajuste/c установочным винтом					

**M**



					Reference	Item No.	
<b>418</b>		<b>128</b>	<b>OM 441 Euro 1</b> <b>986 - 993, 996, 998</b> 01.1991 →    D (LA) 6 10964 cm <sup>3</sup> 2V 230-250 kW (313-340 PS) 16,25:1 142,00 mm 94 331 7..				
	IN [1]	59,0 x 12 x 142,5	A/S - Cr -	- 30° - -	5 - III	A 403 053 09 01 A 422 050 00 26 A 422 050 02 26 A 422 050 05 26 A 422 053 01 01 A 423 050 00 26 A 442 050 02 26 A 442 050 03 26	<b>16117</b>
	IN [1]	59,0 x 12 x 142,5	A/S - Cr -	- 30° - -	5 - III	A 442 050 05 26	<b>16146</b>
	EX [1]	51,0 x 12 x 142,5	RA/S- Cr -	- 45° - -	5 - III	A 422 050 01 27 A 422 050 02 27 A 442 050 01 27 A 442 050 02 27 A 442 050 03 27 A 442 050 04 27	<b>16150</b>
	[50]	Ø 12 mm				A 422 053 00 26	<b>LK-1610</b>
	IN/EX [6]	18,03 x 12 x 67,0	G2			A 422 053 04 30	<b>81-16100</b>
	IN [2]	60,11 x 51.2 x 8,4	G1 30°			A 422 053 05 31	<b>92-16151</b>
	IN [1]	60,31 x 51.2 x 8,6	G1 30°			A 422 053 06 31	<b>92-16152</b>
	EX [2]	53,11 x 43 x 9,2	G1 45°			A 442 053 00 32	<b>92-16127</b>
	EX [1]	53,11 x 43 x 9,2	G1 45°			A 422 053 01 32	<b>92-16126</b>
	EX [1]	53,31 x 43 x 9,4	G1 45°			A 442 053 01 32	<b>92-16149</b>
	EX [1]	53,51 x 43.2 x 9,6	G1 45°			A 442 053 02 32	<b>92-16128</b>
		566 mm				A 401 050 19 01 A 401 050 22 01 A 441 050 17 01	<b>20 1003 40101</b>
	[12]	M 31,5 x 76,5 x 20				A 403 054 09 01 A 403 054 18 01	<b>20 1003 40060</b>
	[12]	M 32 x 76 x 20				A 422 050 03 25 A 476 050 00 25	<b>20 1003 44000</b> (1)
	[12]	M 32 x 76 x 20				A 422 050 03 25 A 476 050 00 25	<b>20 1003 44001</b> <b>NEW</b> (2)
	(1)	OES specification					
	(2)	IAM specification					
	[4]					A 403 050 07 33 A 442 050 03 33	<b>20 1002 25010</b> (3)
	[1]					A 403 050 03 33 A 403 050 07 33 A 442 050 03 33	<b>20 1003 40010</b>
	[1]					A 403 050 03 33 A 403 050 07 33 A 442 050 03 33 A 442 055 00 20	<b>20 1003 40012</b> (4)
	(3)	nur 2-Ventiler/only 2 valves version/seulement 2 soupapes/sólo sistemas de 2 válvulas/заменяемо 2 Клапаны					
	(4)	mit Einstellschraube/with adjusting screw/avec vis de réglage/con tornillo de ajuste/c установочным винтом					
Fortsetzung nächste Seite / continued on next page / suite page suivante / continuación página próxima / Продолжение на следующей странице							

					Reference	Item No.
	- V - G - S -	- - - EVB	ready-to-install		A 442 010 06 20	20 0803 44000
					A 442 010 06 20	20 0803 44010
	- - G - S -	- - - -				

## 419 128

OM 441

901-520

03.1991 → 02.1991 D (LA) 6 10965 cm<sup>3</sup> 2V

142,00 mm

90 220 6.., 91 630 6.., 94 331 7.., 94 512 6.., 94 681 6.., 99 973 6..

	IN [1]	59,0 x 12 x 142,5	A/S - Cr -	- 30° - -	5 - III	A 403 053 09 01 A 422 050 00 26 A 422 050 02 26 A 422 050 05 26 A 422 053 01 01 A 423 050 00 26 A 442 050 02 26 A 442 050 03 26	16117
	IN [1]	59,0 x 12 x 142,5	A/S - Cr -	- 30° - -	5 - III	A 442 050 05 26	16146
	EX [1]	51,0 x 12 x 142,5	A/S - Cr -	- 45° - -	5 - III	A 422 050 00 27	16116
	EX [1]	51,0 x 12 x 142,5	RA/S- Cr -	- 45° - -	5 - III	A 422 050 01 27 A 422 050 02 27 A 442 050 01 27 A 442 050 02 27 A 442 050 03 27 A 442 050 04 27	16150
	[50]	Ø 12 mm				A 422 053 00 26	LK-1610
	IN/EX [6]	18,03 x 12 x 67,0	G2			A 422 053 04 30	81-16100
	IN [2]	60,11 x 51.2 x 8,4	G1 30°			A 422 053 05 31	92-16151
	IN [1]	60,31 x 51.2 x 8,6	G1 30°			A 422 053 06 31	92-16152
	EX [2]	53,11 x 43 x 9,2	G1 45°			A 442 053 00 32	92-16127
	EX [1]	53,11 x 43 x 9,2	G1 45°			A 422 053 01 32	92-16126
	EX [1]	53,31 x 43 x 9,4	G1 45°			A 442 053 01 32	92-16149
		566 mm				A 401 050 19 01 A 401 050 22 01 A 441 050 17 01	20 1003 40101
	[12]	M 32 x 76 x 20				A 422 050 03 25 A 476 050 00 25	20 1003 44000 (1)
	[12]	M 32 x 76 x 20				A 422 050 03 25 A 476 050 00 25	20 1003 44001 <b>NEW</b> (2)
	(1)	OES specification					
	(2)	IAM specification					

Fortsetzung nächste Seite / continued on next page / suite page suivante / continuación página próxima / Продолжение на следующей странице

					Reference	Item No.
[4] [1] [1]					A 403 050 07 33 A 442 050 03 33 A 403 050 03 33 A 403 050 07 33 A 442 050 03 33 A 403 050 03 33 A 403 050 07 33 A 442 050 03 33 A 442 055 00 20	20 1002 25010 (3)  20 1003 40010  20 1003 40012 (4)
(3) nur 2-Ventiler/only 2 valves version/seulement 2 soupapes/sólo sistemas de 2 válvulas/заменяемо 2 Клапаны						
(4) mit Einstellschraube/with adjusting screw/avec vis de réglage/con tornillo de ajuste/c установочным ВИНТОМ						
	- V - G - S -	- - - EVB	ready-to-install		A 442 010 06 20	20 0803 44000
	- - G - S -	- - - -			A 442 010 06 20	20 0803 44010

M

**420** **128**

**OM 441 Euro 0 955**  
03.1991 → 02.1991 D (A) 6 10965 cm<sup>3</sup> 2V 200 kW (272 PS) 16,25:1 142,00 mm  
90 220 6..., 91 630 6..., 94 512 6..., 99 973 6...

IN [1]	59,0 x 12 x 142,5	A/S - Cr -	- 30° - -	5 - III	A 403 053 09 01 A 422 050 00 26 A 422 050 02 26 A 422 050 05 26 A 422 053 01 01 A 423 050 00 26 A 442 050 02 26 A 442 050 03 26	16117
IN [1]	59,0 x 12 x 142,5	A/S - Cr -	- 30° - -	5 - III	A 442 050 05 26	16146
EX [1]	51,0 x 12 x 142,5	A/S - Cr -	- 45° - -	5 - III	A 422 050 00 27	16116
EX [1]	51,0 x 12 x 142,5	RA/S- Cr -	- 45° - -	5 - III	A 422 050 01 27 A 422 050 02 27 A 442 050 01 27 A 442 050 02 27 A 442 050 03 27 A 442 050 04 27	16150
[50]	Ø 12 mm				A 422 053 00 26	LK-1610
IN/EX [6]	18,03 x 12 x 67,0	G2			A 422 053 04 30	81-16100
IN [2]	60,11 x 51.2 x 8,4	G1 45°			A 442 053 05 31	92-16122
IN [1]	60,51 x 51.2 x 8,9	G1 30°			A 442 053 07 31	92-16123
EX [2]	53,11 x 43 x 9,2	G1 45°			A 442 053 00 32	92-16127
EX [1]	53,11 x 43 x 9,2	G1 45°			A 422 053 01 32	92-16126
EX [1]	53,31 x 43 x 9,4	G1 45°			A 442 053 01 32	92-16149
EX [1]	53,51 x 43.2 x 9,6	G1 45°			A 442 053 02 32	92-16128

					Reference	Item No.	
<b>421</b>		<b>128</b>	<b>OM 442 901-502</b>				
03.1991 → 02.1991 D (LA) 8 14618 cm <sup>3</sup> 2V						142,00 mm	
90 220 6.., 91 630 6.., 94 331 7.., 94 512 6.., 99 973 6..							
	IN [1]	59,0 x 12 x 142,5	A/S - Cr -	- 30° - -	5 - III	A 403 053 09 01 A 422 050 00 26 A 422 050 02 26 A 422 050 05 26 A 422 053 01 01 A 423 050 00 26 A 442 050 02 26 A 442 050 03 26	<b>16117</b>
	IN [1]	59,0 x 12 x 142,5	A/S - Cr -	- 30° - -	5 - III	A 442 050 05 26	<b>16146</b>
	EX [1]	51,0 x 12 x 142,5	RA/S- Cr -	- 45° - -	5 - III	A 422 050 01 27 A 422 050 02 27 A 442 050 01 27 A 442 050 02 27 A 442 050 03 27 A 442 050 04 27	<b>16150</b>
	[50]	Ø 12 mm				A 422 053 00 26	<b>LK-1610</b>
	IN/EX [6]	18,03 x 12 x 67,0	G2			A 422 053 04 30	<b>81-16100</b>
	IN [2]	60,11 x 51.2 x 8,4	G1 30°			A 422 053 05 31	<b>92-16151</b>
	IN [2]	60,11 x 51.2 x 8,4	G1 45°			A 442 053 05 31	<b>92-16122</b>
	IN [1]	60,31 x 51.2 x 8,6	G1 30°			A 422 053 06 31	<b>92-16152</b>
	IN [1]	60,51 x 51.2 x 8,9	G1 30°			A 442 053 07 31	<b>92-16123</b>
	EX [2]	53,11 x 43 x 9,2	G1 45°			A 442 053 00 32	<b>92-16127</b>
	EX [1]	53,11 x 43 x 9,2	G1 45°			A 422 053 01 32	<b>92-16126</b>
	EX [1]	53,31 x 43 x 9,4	G1 45°			A 442 053 01 32	<b>92-16149</b>
	EX [1]	53,51 x 43.2 x 9,6	G1 45°			A 442 053 02 32	<b>92-16128</b>
		724 mm				A 422 050 00 01 A 422 050 04 01 A 422 050 10 01 A 422 050 22 01	<b>20 1003 42201</b>
	[12]	M 31,5 x 76,5 x 20				A 403 054 09 01 A 403 054 18 01	<b>20 1003 40060</b>
	[12]	M 32 x 76 x 20				A 422 050 03 25 A 476 050 00 25	<b>20 1003 44000</b> (1)
	[12]	M 32 x 76 x 20				A 422 050 03 25 A 476 050 00 25	<b>20 1003 44001</b> (2)
	(1)	OES specification					
	(2)	IAM specification					
	[4]					A 403 050 07 33 A 442 050 03 33	<b>20 1002 25010</b> (3)
	[1]					A 403 050 03 33 A 403 050 07 33 A 442 050 03 33	<b>20 1003 40010</b>
	[1]					A 403 050 03 33 A 403 050 07 33 A 442 050 03 33 A 442 055 00 20	<b>20 1003 40012</b> (4)
	(3)	nur 2-Ventiler/only 2 valves version/seulement 2 soupapes/sólo sistemas de 2 válvulas/заменяемо 2 Клапаны					
	(4)	mit Einstellschraube/with adjusting screw/avec vis de réglage/con tornillo de ajuste/c установочным винтом					
Fortsetzung nächste Seite / continued on next page / suite page suivante / continuación página próxima / Продолжение на следующей странице							

**M**

					Reference	Item No.
	- V - G - S -	- - - EVB	ready-to-install		A 442 010 06 20	20 0803 44000
		- - G - S -	- - -		A 442 010 06 20	20 0803 44010

## 422 128

OM 442

901-500, 901-520

03.1991 → 12.2003 D (LA) 8 14618 cm<sup>3</sup> 2V

142,00 mm

90 220 6..., 91 630 6..., 94 331 7..., 94 512 6..., 94 681 6..., 99 973 6..

	IN [1]	59,0 x 12 x 142,5	A/S - Cr -	- 30° - -	5 - III	A 403 053 09 01 A 422 050 00 26 A 422 050 02 26 A 422 050 05 26 A 422 053 01 01 A 423 050 00 26 A 442 050 02 26 A 442 050 03 26	16117	
	IN [1] EX [2]	59,0 x 12 x 142,5 17,1 x 8 x 90,3	A/S - Cr - A - -	- 30° - - - 45° - -	5 - III 1 -	A 442 050 05 26 A 442 016 02 91 A 442 016 03 91	16146 50 004 665 (1)	
	EX [1]	51,0 x 12 x 142,5	RA/S- Cr -	- 45° - -	5 - III	A 422 050 01 27 A 422 050 02 27 A 442 050 01 27 A 442 050 02 27 A 442 050 03 27 A 442 050 04 27	16150	
	(1)	Konstantdrosselventil - Dom Exhaust brake valve - dome Papillon constant - Dôme Válvula de estrangulamiento constante - Dom Нерегулируемый дроссельный клапан - собор						
	[50]	Ø 12 mm				A 422 053 00 26	LK-1610	
	IN/EX [6]	18,03 x 12 x 67,0	G2			A 422 053 04 30	81-16100	
	IN [2] IN [1] EX [2] EX [1] EX [1] EX [1]	60,11 x 51.2 x 8,4 60,31 x 51.2 x 8,6 53,11 x 43 x 9,2 53,11 x 43 x 9,2 53,31 x 43 x 9,4 53,51 x 43.2 x 9,6	G1 G1 G1 G1 G1 G1	30° 30° 45° 45° 45° 45°		A 422 053 05 31 A 422 053 06 31 A 442 053 00 32 A 422 053 01 32 A 442 053 01 32 A 442 053 02 32	92-16151 92-16152 92-16127 92-16126 92-16149 92-16128	
		724 mm				A 422 050 00 01 A 422 050 04 01 A 422 050 10 01 A 422 050 22 01	20 1003 42201	

Fortsetzung nächste Seite / continued on next page / suite page suivante / continuación página próxima / Продолжение на следующей странице



					Reference	Item No.
[12]	M 31,5 x 76,5 x 20				A 403 054 09 01 A 403 054 18 01	<b>20 1003 40060</b>
[12]	M 32 x 76 x 20				A 422 050 03 25 A 476 050 00 25	<b>20 1003 44000</b> (2)
[12]	M 32 x 76 x 20				A 422 050 03 25 A 476 050 00 25	<b>20 1003 44001</b> <b>NEW</b> (3)
(2)	OES specification					
(3)	IAM specification					
[4]					A 403 050 07 33 A 442 050 03 33	<b>20 1002 25010</b> (4)
[1]					A 403 050 03 33 A 403 050 07 33 A 442 050 03 33	<b>20 1003 40010</b>
[1]					A 403 050 03 33 A 403 050 07 33 A 442 050 03 33 A 442 055 00 20	<b>20 1003 40012</b> (5)
(4)	nur 2-Ventiler/only 2 valves version/seulement 2 soupapes/sólo sistemas de 2 válvulas/заменяемо 2 Клапаны					
(5)	mit Einstellschraube/with adjusting screw/avec vis de réglage/con tornillo de ajuste/c установочным винтом					
	- V - G - S -	- - - EVB	ready-to-install		A 442 010 06 20	<b>20 0803 44000</b>
	- - G - S -	- - -			A 442 010 06 20	<b>20 0803 44010</b>

**M**

**423** **128**

OM 442

901/-400

03.1991 → 12.2003 D (LA) 8 14618 cm<sup>3</sup> 2V

142,00 mm

90 220 6.., 91 630 6.., 94 331 7.., 94 512 6.., 99 973 6..

IN [1]	59,0 x 12 x 142,5	A/S - Cr -	- 30° - -	5 - III	A 403 053 09 01 A 422 050 00 26 A 422 050 02 26 A 422 050 05 26 A 422 053 01 01 A 423 050 00 26 A 442 050 02 26 A 442 050 03 26	<b>16117</b>
IN [1]	59,0 x 12 x 142,5	A/S - Cr -	- 30° - -	5 - III	A 442 050 05 26	<b>16146</b>
EX [2]	17,1 x 8 x 90,3	A - -	- 45° - -	1 -	A 442 016 02 91 A 442 016 03 91	<b>50 004 665</b> (1)
EX [1]	51,0 x 12 x 142,5	RA/S- Cr -	- 45° - -	5 - III	A 422 050 01 27 A 422 050 02 27 A 442 050 01 27 A 442 050 02 27 A 442 050 03 27 A 442 050 04 27	<b>16150</b>

Fortsetzung nächste Seite / continued on next page / suite page suivante / continuación página próxima / Продолжение на следующей странице

					Reference	Item No.
(1)	Konstantdrosselventil - Dom Exhaust brake valve - dome Papillon constant - Dôme Válvula de estrangulamiento constante - Dom Нерегулируемый дроссельный клапан - собор					
[50]	Ø 12 mm				A 422 053 00 26	<b>LK-1610</b>
IN/EX [6]	18,03 x 12 x 67,0	G2			A 422 053 04 30	<b>81-16100</b>
	IN [2] IN [2] IN [1] IN [1] EX [2] EX [1] EX [1] EX [1]	60,11 x 51.2 x 8,4 60,11 x 51.2 x 8,4 60,31 x 51.2 x 8,6 60,51 x 51.2 x 8,9 53,11 x 43 x 9,2 53,11 x 43 x 9,2 53,31 x 43 x 9,4 53,51 x 43.2 x 9,6	G1 30° G1 45° G1 30° G1 30° G1 45° G1 45° G1 45° G1 45°		A 422 053 05 31 A 442 053 05 31 A 422 053 06 31 A 442 053 07 31 A 442 053 00 32 A 422 053 01 32 A 442 053 01 32 A 442 053 02 32	<b>92-16151</b> <b>92-16122</b> <b>92-16152</b> <b>92-16123</b> <b>92-16127</b> <b>92-16126</b> <b>92-16149</b> <b>92-16128</b>
	724 mm				A 422 050 00 01 A 422 050 04 01 A 422 050 10 01 A 422 050 22 01	<b>20 1003 42201</b>
[12]	M 31,5 x 76,5 x 20				A 403 054 09 01 A 403 054 18 01	<b>20 1003 40060</b>
[12]	M 32 x 76 x 20				A 422 050 03 25 A 476 050 00 25	<b>20 1003 44000</b> (2)
[12]	M 32 x 76 x 20				A 422 050 03 25 A 476 050 00 25	<b>20 1003 44001</b> (3)
	(2) OES specification					
	(3) IAM specification					
[4]					A 403 050 07 33 A 442 050 03 33	<b>20 1002 25010</b> (4)
[1]					A 403 050 03 33 A 403 050 07 33 A 442 050 03 33	<b>20 1003 40010</b>
[1]					A 403 050 03 33 A 403 050 07 33 A 442 050 03 33 A 442 055 00 20	<b>20 1003 40012</b> (5)
	(4) nur 2-Ventiler/only 2 valves version/seulement 2 soupapes/sólo sistemas de 2 válvulas/заменяемо 2 Клапаны					
	(5) mit Einstellschraube/with adjusting screw/avec vis de réglage/con tornillo de ajuste/c установочным винтом					
	- V - G - S -	- - -	- EVB	ready-to-install	A 442 010 06 20	<b>20 0803 44000</b>
	- - G - S -	- - -			A 442 010 06 20	<b>20 0803 44010</b>

M

					Reference	Item No.	
<b>424</b>		<b>128</b>	<b>OM 440 Euro 1 980, 984 - 985, 987 - 988, 990 - 991</b> 03.1991 → D (LA) 8 14618 cm <sup>3</sup> 2V 280-320 kW (381-435 PS) 16,75:1 142,00 mm 94 331 7..				
	IN [1]	59,0 x 12 x 142,5	A/S - Cr -	- 30° - -	5 - III	A 403 053 09 01 A 422 050 00 26 A 422 050 02 26 A 422 050 05 26 A 422 053 01 01 A 423 050 00 26 A 442 050 02 26 A 442 050 03 26	<b>16117</b>
	IN [1]	59,0 x 12 x 142,5	A/S - Cr -	- 30° - -	5 - III	A 442 050 05 26	<b>16146</b>
	EX [1]	51,0 x 12 x 142,5	RA/S- Cr -	- 45° - -	5 - III	A 422 050 01 27 A 422 050 02 27 A 442 050 01 27 A 442 050 02 27 A 442 050 03 27 A 442 050 04 27	<b>16150</b>
	[50]	Ø 12 mm				A 422 053 00 26	<b>LK-1610</b>
	IN/EX [6]	18,03 x 12 x 67,0	G2			A 422 053 04 30	<b>81-16100</b>
	IN [2]	60,11 x 51.2 x 8,4	G1 30°			A 422 053 05 31	<b>92-16151</b>
	IN [1]	60,31 x 51.2 x 8,6	G1 30°			A 422 053 06 31	<b>92-16152</b>
	EX [2]	53,11 x 43 x 9,2	G1 45°			A 442 053 00 32	<b>92-16127</b>
	EX [1]	53,11 x 43 x 9,2	G1 45°			A 422 053 01 32	<b>92-16126</b>
	EX [1]	53,31 x 43 x 9,4	G1 45°			A 442 053 01 32	<b>92-16149</b>
	EX [1]	53,51 x 43.2 x 9,6	G1 45°			A 442 053 02 32	<b>92-16128</b>
		724 mm				A 402 050 21 01 A 402 050 25 01 A 442 050 17 01	<b>20 1003 40201</b>
	[12]	M 32 x 76 x 20				A 422 050 03 25 A 476 050 00 25	<b>20 1003 44000</b> (1)
	[12]	M 32 x 76 x 20				A 422 050 03 25 A 476 050 00 25	<b>20 1003 44001</b> <small>NEW</small> (2)
	(1)	OES specification					
	(2)	IAM specification					
	[4]					A 403 050 07 33 A 442 050 03 33	<b>20 1002 25010</b> (3)
	[1]					A 403 050 03 33 A 403 050 07 33 A 442 050 03 33	<b>20 1003 40010</b>
	[1]					A 403 050 03 33 A 403 050 07 33 A 442 050 03 33 A 442 055 00 20	<b>20 1003 40012</b> (4)
	(3)	nur 2-Ventiler/only 2 valves version/seulement 2 soupapes/sólo sistemas de 2 válvulas/заменяемо 2 Клапаны					
	(4)	mit Einstellschraube/with adjusting screw/avec vis de réglage/con tornillo de ajuste/c установочным винтом					
Fortsetzung nächste Seite / continued on next page / suite page suivante / continuación página próxima / Продолжение на следующей странице							

M

					Reference	Item No.
	- V - G - S -	- - - EVB	ready-to-install		A 442 010 06 20	<b>20 0803 44000</b>
		- - G - S -			A 442 010 06 20	<b>20 0803 44010</b>

## 425 128

<b>OM 441</b>	<b>901-400</b> 03.1991 → 02.1991	D (A)	6	10965 cm <sup>3</sup>	2V	142,00 mm
<b>OM 441</b>	<b>901-500, 901-504, 901-505</b> 03.1991 →	D (LA)	6	10965 cm <sup>3</sup>	2V	142,00 mm
<b>OM 441 Euro 2</b>	<b>901-507</b> 1995 →	D (LA)	6	10965 cm <sup>3</sup>	2V	142,00 mm

90 220 6.., 91 630 6.., 94 331 7.., 94 512 6.., 94 681 6.., 99 973 6..

M

	IN [1]	59,0 x 12 x 142,5	A/S - Cr -	- 30° - -	5 - III	A 403 053 09 01 A 422 050 00 26 A 422 050 02 26 A 422 050 05 26 A 422 053 01 01 A 423 050 00 26 A 442 050 02 26 A 442 050 03 26	<b>16117</b>
	IN [1]	59,0 x 12 x 142,5	A/S - Cr -	- 30° - -	5 - III	A 442 050 05 26	<b>16146</b>
	EX [1]	51,0 x 12 x 142,5	A/S - Cr -	- 45° - -	5 - III	A 422 050 00 27	<b>16116</b>
	EX [1]	51,0 x 12 x 142,5	RA/S- Cr -	- 45° - -	5 - III	A 422 050 01 27 A 422 050 02 27 A 442 050 01 27 A 442 050 02 27 A 442 050 03 27 A 442 050 04 27	<b>16150</b>
	[50]	∅ 12 mm				A 422 053 00 26	<b>LK-1610</b>
	IN/EX [6]	18,03 x 12 x 67,0	G2			A 422 053 04 30	<b>81-16100</b>
	IN [2]	60,11 x 51.2 x 8,4	G1 30°			A 422 053 05 31	<b>92-16151</b>
	IN [1]	60,31 x 51.2 x 8,6	G1 30°			A 422 053 06 31	<b>92-16152</b>
	EX [2]	53,11 x 43 x 9,2	G1 45°			A 442 053 00 32	<b>92-16127</b>
	EX [1]	53,11 x 43 x 9,2	G1 45°			A 422 053 01 32	<b>92-16126</b>
	EX [1]	53,31 x 43 x 9,4	G1 45°			A 442 053 01 32	<b>92-16149</b>
	EX [1]	53,51 x 43.2 x 9,6	G1 45°			A 442 053 02 32	<b>92-16128</b>
		566 mm				A 401 050 19 01 A 401 050 22 01 A 441 050 17 01	<b>20 1003 40101</b>
	[12]	M 32 x 76 x 20				A 422 050 03 25 A 476 050 00 25	<b>20 1003 44000</b> (1)
	[12]	M 32 x 76 x 20				A 422 050 03 25 A 476 050 00 25	<b>20 1003 44001</b> <b>NEW</b> (2)
	(1)	OES specification					
	(2)	IAM specification					

Fortsetzung nächste Seite / continued on next page / suite page suivante / continuación página próxima / Продолжение на следующей странице

					Reference	Item No.
[4]					A 403 050 07 33	20 1002 25010 (3)
[1]					A 442 050 03 33	20 1003 40010
[1]					A 403 050 03 33	
					A 403 050 07 33	20 1003 40012 (4)
					A 442 050 03 33	
					A 403 050 07 33	
					A 442 050 03 33	
					A 442 055 00 20	
(3)	nur 2-Ventiler/only 2 valves version/seulement 2 soupapes/sólo sistemas de 2 válvulas/заменяемо 2 Клапаны					
(4)	mit Einstellschraube/with adjusting screw/avec vis de réglage/con tornillo de ajuste/c установочным винтом					
	- V - G - S -	- - - EVB	ready-to-install		A 442 010 06 20	20 0803 44000
	- - G - S -	- - -			A 442 010 06 20	20 0803 44010

**426**
**128**
**OM 441**
**901-530**

03.1991 →

D (LA)

6

 10965 cm<sup>3</sup> 2V

250 kW

(340 PS)

142,00 mm

90 220 6..., 91 630 6..., 94 331 7..., 94 512 6..., 94 681 6..., 99 973 6..

IN [1]	59,0 x 12 x 142,5	A/S - Cr -	- 30° -	-	5 - III	A 403 053 09 01 A 422 050 00 26 A 422 050 02 26 A 422 050 05 26 A 422 053 01 01 A 423 050 00 26 A 442 050 02 26 A 442 050 03 26	16117
IN [1]	59,0 x 12 x 142,5	A/S - Cr -	- 30° -	-	5 - III	A 442 050 05 26	16146
EX [1]	51,0 x 12 x 142,5	RA/S- Cr -	- 45° -	-	5 - III	A 422 050 01 27 A 422 050 02 27 A 442 050 01 27 A 442 050 02 27 A 442 050 03 27 A 442 050 04 27	16150
[50]	∅ 12 mm					A 422 053 00 26	LK-1610
IN/EX [6]	18,03 x 12 x 67,0	G2				A 422 053 04 30	81-16100
IN [2]	60,11 x 51.2 x 8,4	G1 30°				A 422 053 05 31	92-16151
IN [1]	60,31 x 51.2 x 8,6	G1 30°				A 422 053 06 31	92-16152
EX [2]	53,11 x 43 x 9,2	G1 45°				A 442 053 00 32	92-16127
EX [1]	53,11 x 43 x 9,2	G1 45°				A 422 053 01 32	92-16126
EX [1]	53,31 x 43 x 9,4	G1 45°				A 442 053 01 32	92-16149
EX [1]	53,51 x 43.2 x 9,6	G1 45°				A 442 053 02 32	92-16128

Fortsetzung nächste Seite / continued on next page / suite page suivante / continuación página próxima / Продолжение на следующей странице



					Reference	Item No.
	566 mm				A 401 050 19 01 A 401 050 22 01 A 441 050 17 01	<b>20 1003 40101</b>
	[12] M 32 x 76 x 20				A 422 050 03 25 A 476 050 00 25	<b>20 1003 44000</b> (1)
	[12] M 32 x 76 x 20				A 422 050 03 25 A 476 050 00 25	<b>20 1003 44001</b> (2)
	(1) OES specification					
	(2) IAM specification					
	[4]				A 403 050 07 33 A 442 050 03 33	<b>20 1002 25010</b> (3)
	[1]				A 403 050 03 33 A 403 050 07 33 A 442 050 03 33	<b>20 1003 40010</b>
	[1]				A 403 050 03 33 A 403 050 07 33 A 442 050 03 33 A 442 055 00 20	<b>20 1003 40012</b> (4)
	(3) nur 2-Ventiler/only 2 valves version/seulement 2 soupapes/sólo sistemas de 2 válvulas/заменяемо 2 Клапаны					
	(4) mit Einstellschraube/with adjusting screw/avec vis de réglage/con tornillo de ajuste/c установочным ВИНТОМ					
	- V - G - S -	- - - EVB	ready-to-install		A 442 010 06 20	<b>20 0803 44000</b>
	- - G - S -	- - -			A 442 010 06 20	<b>20 0803 44010</b>

## 427 128

<b>OM 442 Euro 1</b>	<b>901-404</b>					
	07.1995 →	D (A)	8	14618 cm <sup>3</sup>	2V	142,00 mm
<b>OM 442 Euro 2</b>	<b>901-508</b>					
		D (LA)	8	14618 cm <sup>3</sup>	2V	142,00 mm
<b>OM 442 Euro 1</b>	<b>901-504, 901-505, 901-506</b>					
	03.1991 →	D (LA)	8	14618 cm <sup>3</sup>	2V	142,00 mm
<b>OM 442</b>	<b>901-501</b>					
	03.1991 → 02.1991	D (LA)	8	14618 cm <sup>3</sup>	2V	142,00 mm

90 220 6.., 91 630 6.., 94 331 7.., 94 512 6.., 94 681 6.., 99 973 6..

Fortsetzung nächste Seite / continued on next page / suite page suivante / continuación página próxima / Продолжение на следующей странице

					Reference	Item No.
	IN [1] 59,0 x 12 x 142,5	A/S - Cr -	- 30° - -	5 - III	A 403 053 09 01 A 422 050 00 26 A 422 050 02 26 A 422 050 05 26 A 422 053 01 01 A 423 050 00 26 A 442 050 02 26 A 442 050 03 26	<b>16117</b>
	IN [1] EX [1] 59,0 x 12 x 142,5 51,0 x 12 x 142,5	A/S - Cr - RA/S- Cr -	- 30° - - - 45° - -	5 - III 5 - III	A 442 050 05 26 A 422 050 01 27 A 422 050 02 27 A 442 050 01 27 A 442 050 02 27 A 442 050 03 27 A 442 050 04 27	<b>16146</b> <b>16150</b>
	[50] Ø 12 mm				A 422 053 00 26	<b>LK-1610</b>
	IN/EX [6] 18,03 x 12 x 67,0	G2			A 422 053 04 30	<b>81-16100</b>
	IN [2] IN [1] EX [2] EX [1] EX [1] EX [1] 60,11 x 51.2 x 8,4 60,31 x 51.2 x 8,6 53,11 x 43 x 9,2 53,11 x 43 x 9,2 53,31 x 43 x 9,4 53,51 x 43.2 x 9,6	G1 30° G1 30° G1 45° G1 45° G1 45° G1 45°			A 422 053 05 31 A 422 053 06 31 A 442 053 00 32 A 422 053 01 32 A 442 053 01 32 A 442 053 02 32	<b>92-16151</b> <b>92-16152</b> <b>92-16127</b> <b>92-16126</b> <b>92-16149</b> <b>92-16128</b>
	724 mm				A 422 050 00 01 A 422 050 04 01 A 422 050 10 01 A 422 050 22 01	<b>20 1003 42201</b>
	[12] M 31,5 x 76,5 x 20				A 403 054 09 01 A 403 054 18 01	<b>20 1003 40060</b>
	[12] M 32 x 76 x 20				A 422 050 03 25 A 476 050 00 25	<b>20 1003 44000</b> (1)
	[12] M 32 x 76 x 20				A 422 050 03 25 A 476 050 00 25	<b>20 1003 44001</b> <b>NEW</b> (2)
	(1) OES specification (2) IAM specification					
	[4] [1] [1]				A 403 050 07 33 A 442 050 03 33 A 403 050 03 33 A 403 050 07 33 A 442 050 03 33 A 403 050 03 33 A 403 050 07 33 A 442 050 03 33 A 442 055 00 20	<b>20 1002 25010</b> (3) <b>20 1003 40010</b> <b>20 1003 40012</b> (4)
	(3) nur 2-Ventiler/only 2 valves version/seulement 2 soupapes/sólo sistemas de 2 válvulas/заменяемо 2 Клапаны					
	(4) mit Einstellschraube/with adjusting screw/avec vis de réglage/con tornillo de ajuste/c установочным винтом					
Fortsetzung nächste Seite / continued on next page / suite page suivante / continuación página próxima / Продолжение на следующей странице						

M

					Reference	Item No.
	- V - G - S -	- - - EVB	ready-to-install		A 442 010 06 20	20 0803 44000
		- - G - S -	- - -		A 442 010 06 20	20 0803 44010

## 428 128

OM 441 Euro 1

980, 994 - 995, 997, 999

09.1991 →

D (LA)

6

10964 cm<sup>3</sup> 2V

230-250 kW

(313-340 PS) 16,25:1 142,00 mm

94 331 7..

	IN [1]	59,0 x 12 x 142,5	A/S - Cr -	- 30° - -	5 - III	A 403 053 09 01 A 422 050 00 26 A 422 050 02 26 A 422 050 05 26 A 422 053 01 01 A 423 050 00 26 A 442 050 02 26 A 442 050 03 26	16117
	IN [1]	59,0 x 12 x 142,5	A/S - Cr -	- 30° - -	5 - III	A 442 050 05 26	16146
	EX [1]	51,0 x 12 x 142,5	RA/S- Cr -	- 45° - -	5 - III	A 422 050 01 27 A 422 050 02 27 A 442 050 01 27 A 442 050 02 27 A 442 050 03 27 A 442 050 04 27	16150
	[50]	Ø 12 mm				A 422 053 00 26	LK-1610
	IN/EX [6]	18,03 x 12 x 67,0	G2			A 422 053 04 30	81-16100
	IN [2]	60,11 x 51.2 x 8,4	G1 30°			A 422 053 05 31	92-16151
	IN [1]	60,31 x 51.2 x 8,6	G1 30°			A 422 053 06 31	92-16152
	EX [2]	53,11 x 43 x 9,2	G1 45°			A 442 053 00 32	92-16127
	EX [1]	53,11 x 43 x 9,2	G1 45°			A 422 053 01 32	92-16126
	EX [1]	53,31 x 43 x 9,4	G1 45°			A 442 053 01 32	92-16149
	EX [1]	53,51 x 43.2 x 9,6	G1 45°			A 442 053 02 32	92-16128
		566 mm				A 401 050 19 01 A 401 050 22 01 A 441 050 17 01	20 1003 40101
	[12]	M 31,5 x 76,5 x 20				A 403 054 09 01 A 403 054 18 01	20 1003 40060
	[12]	M 32 x 76 x 20				A 422 050 03 25 A 476 050 00 25	20 1003 44000 (1)
	[12]	M 32 x 76 x 20				A 422 050 03 25 A 476 050 00 25	20 1003 44001 <b>NEW</b> (2)
	(1)	OES specification					
	(2)	IAM specification					

Fortsetzung nächste Seite / continued on next page / suite page suivante / continuación página próxima / Продолжение на следующей странице

					Reference	Item No.
[4]					A 403 050 07 33	20 1002 25010 (3)
[1]					A 442 050 03 33	20 1003 40010
[1]					A 403 050 03 33	
					A 403 050 07 33	20 1003 40012 (4)
					A 442 050 03 33	
					A 403 050 07 33	
					A 442 050 03 33	
					A 442 055 00 20	
(3)					nur 2-Ventiler/only 2 valves version/seulement 2 soupapes/sólo sistemas de 2 válvulas/заменяемо 2 Клапаны	
(4)					mit Einstellschraube/with adjusting screw/avec vis de réglage/con tornillo de ajuste/c установочным винтом	
	- - G - S -	- - - -			A 402 010 03 20	20 0803 40300
					A 403 010 40 20	
					A 403 010 89 20	
					A 427 010 00 20	
					A 427 010 10 20	
					A 429 010 02 20	
					A 442 010 07 20	
						20 0803 40301
	- V - G - S -	- - - -	ready-to-install		A 427 010 10 20	

## 429 128

OM 447 Euro 2 **968**  
09.1991→ D (LA) 6 11967 cm<sup>3</sup> 2V 235 kW (320 PS) 18:1 155,00 mm

IN [1]	59,0 x 12 x 142,5	A/S - Cr -	- 30° - -	5 - III	A 403 053 09 01	16117
					A 422 050 00 26	
					A 422 050 02 26	
					A 422 050 05 26	
					A 422 053 01 01	
					A 423 050 00 26	
					A 442 050 02 26	
					A 442 050 03 26	
					A 442 050 05 26	
					A 442 050 07 26	
					A 442 050 01 27	16146 16150
IN [1]	59,0 x 12 x 142,5	A/S - Cr -	- 30° - -	5 - III	A 422 050 02 27	
EX [1]	51,0 x 12 x 142,5	RA/S- Cr -	- 45° - -	5 - III	A 442 050 01 27	
					A 442 050 02 27	
					A 442 050 02 27	
					A 442 050 03 27	
					A 442 050 04 27	
[50]	Ø 12 mm				A 422 053 00 26	LK-1610
IN/EX [6]	18,03 x 12 x 67,0	G2			A 422 053 04 30	81-16100

Fortsetzung nächste Seite / continued on next page / suite page suivante / continuación página próxima / Продолжение на следующей странице

					Reference	Item No.
IN [1]	60,11 x 49.3 x 8,4	G1 30°			A 422 053 01 31 A 447 053 00 31	<b>92-16150</b>
EX [2]	53,11 x 43 x 9,2	G1 45°			A 442 053 00 32	<b>92-16127</b>
EX [1]	53,11 x 43 x 9,2	G1 45°			A 422 053 01 32	<b>92-16126</b>
EX [1]	53,31 x 43 x 9,4	G1 45°			A 442 053 01 32	<b>92-16149</b>
EX [1]	53,51 x 43.2 x 9,6	G1 45°			A 442 053 02 32	<b>92-16128</b>
	1047 mm				A 447 050 19 01	<b>20 1003 44701</b>
[12]	M 32 x 76 x 20				A 422 050 03 25 A 476 050 00 25	<b>20 1003 44000</b> (1)
[12]	M 32 x 76 x 20				A 422 050 03 25 A 476 050 00 25	<b>20 1003 44001</b> (2)
	(1) OES specification					
	(2) IAM specification					
[4]					A 403 050 07 33 A 442 050 03 33	<b>20 1002 25010</b> (3)
[1]					A 403 050 03 33 A 403 050 07 33 A 442 050 03 33	<b>20 1003 40010</b>
[1]					A 403 050 03 33 A 403 050 07 33 A 442 050 03 33 A 442 055 00 20	<b>20 1003 40012</b> (4)
	(3) nur 2-Ventiler/only 2 valves version/seulement 2 soupapes/sólo sistemas de 2 válvulas/заменяемо 2 Клапаны					
	(4) mit Einstellschraube/with adjusting screw/avec vis de réglage/con tornillo de ajuste/c установочным ВИНТОМ					

## 430 128

<b>OM 447 Euro 1</b>	<b>975</b>							
	11.1991 →	D (LA)	6	11967 cm <sup>3</sup>	2V	220 kW	(299 PS)	18:1 155,00 mm
<b>OM 447 Euro 2</b>	<b>970 - 974, 976 - 979, 988, 990 - 991, 993 - 994, 998</b>							
	09.1991 →	D (LA)	6	11967 cm <sup>3</sup>	2V	157-220 kW	(214-300 PS)	18:1 155,00 mm
<b>OM 447 Euro 2</b>	<b>992</b>							
	11.1991 → 12.1998	D (A)	6	11967 cm <sup>3</sup>	2V	184 kW	(250 PS)	18:1 155,00 mm

40 176 6..., 93 171 6..

IN [1]	59,0 x 12 x 142,5	A/S - Cr -	- 30° - -	5 - III	A 403 053 09 01 A 422 050 00 26 A 422 050 02 26 A 422 050 05 26 A 422 053 01 01 A 423 050 00 26 A 442 050 02 26 A 442 050 03 26	<b>16117</b>
IN [1]	59,0 x 12 x 142,5	A/S - Cr -	- 30° - -	5 - III	A 442 050 05 26	<b>16146</b>
EX [1]	51,0 x 12 x 142,5	RA/S- Cr -	- 45° - -	5 - III	A 422 050 01 27 A 422 050 02 27 A 442 050 01 27 A 442 050 02 27 A 442 050 03 27 A 442 050 04 27	<b>16150</b>
[50]	Ø 12 mm				A 422 053 00 26	<b>LK-1610</b>
IN/EX [6]	18,03 x 12 x 67,0	G2			A 422 053 04 30	<b>81-16100</b>

Fortsetzung nächste Seite / continued on next page / suite page suivante / continuación página próxima / Продолжение на следующей странице



					Reference	Item No.
	EX [2] EX [1] EX [1] EX [1]	53,11 x 43 x 9,2 53,11 x 43 x 9,2 53,31 x 43 x 9,4 53,51 x 43.2 x 9,6	G1 45° G1 45° G1 45° G1 45°		A 442 053 00 32 A 422 053 01 32 A 442 053 01 32 A 442 053 02 32	<b>92-16127</b> <b>92-16126</b> <b>92-16149</b> <b>92-16128</b>
	1047 mm				A 447 050 19 01	<b>20 1003 44701</b>
	[12] [12] [12] (1) OES specification (2) IAM specification	M 31,5 x 76,5 x 20 M 32 x 76 x 20 M 32 x 76 x 20			A 403 054 09 01 A 403 054 18 01 A 422 050 03 25 A 476 050 00 25 A 422 050 03 25 A 476 050 00 25	<b>20 1003 40060</b> <b>20 1003 44000</b> (1) <b>20 1003 44001</b> <b>NEW</b> (2)
	[4] [1] [1] (3) nur 2-Ventiler/only 2 valves version/seulement 2 soupapes/sólo sistemas de 2 válvulas/заменяемо 2 Клапаны (4) mit Einstellschraube/with adjusting screw/avec vis de réglage/con tornillo de ajuste/c установочным винтом				A 403 050 07 33 A 442 050 03 33 A 403 050 03 33 A 403 050 07 33 A 442 050 03 33 A 403 050 03 33 A 403 050 07 33 A 442 050 03 33 A 442 055 00 20	<b>20 1002 25010</b> (3) <b>20 1003 40010</b> <b>20 1003 40012</b> (4)

## 431 128

**OM 447 Euro 2 999**  
09.1991 → D (LA) 6 11967 cm<sup>3</sup> 2V 220 kW (299 PS) 18:1 155,00 mm  
40 176 6..., 93 171 6..

	IN [1] IN [1] EX [1]	59,0 x 12 x 142,5 59,0 x 12 x 142,5 51,0 x 12 x 142,5	A/S - Cr - A/S - Cr - RA/S- Cr -	- 30° - - 30° - - 45° -	- - -	5 - III 5 - III 5 - III	A 403 053 09 01 A 422 050 00 26 A 422 050 02 26 A 422 050 05 26 A 422 053 01 01 A 423 050 00 26 A 442 050 02 26 A 442 050 03 26 A 442 050 05 26 A 422 050 01 27 A 422 050 02 27 A 442 050 01 27 A 442 050 02 27 A 442 050 03 27 A 442 050 04 27	<b>16117</b> <b>16146</b> <b>16150</b>
	[50]	Ø 12 mm					A 422 053 00 26	<b>LK-1610</b>
	IN/EX [6]	18,03 x 12 x 67,0	G2				A 422 053 04 30	<b>81-16100</b>
	EX [2] EX [1] EX [1] EX [1]	53,11 x 43 x 9,2 53,11 x 43 x 9,2 53,31 x 43 x 9,4 53,51 x 43.2 x 9,6	G1 45° G1 45° G1 45° G1 45°				A 442 053 00 32 A 422 053 01 32 A 442 053 01 32 A 442 053 02 32	<b>92-16127</b> <b>92-16126</b> <b>92-16149</b> <b>92-16128</b>

Fortsetzung nächste Seite / continued on next page / suite page suivante / continuación página próxima / Продолжение на следующей странице

					Reference	Item No.
[12]	M 32 x 76 x 20				A 422 050 03 25 A 476 050 00 25	<b>20 1003 44000</b> (1)
[12]	M 32 x 76 x 20				A 422 050 03 25 A 476 050 00 25	<b>20 1003 44001</b> (2)
(1) OES specification						
(2) IAM specification						
[4]					A 403 050 07 33 A 442 050 03 33	<b>20 1002 25010</b> (3)
[1]					A 403 050 03 33 A 403 050 07 33 A 442 050 03 33	<b>20 1003 40010</b>
[1]					A 403 050 03 33 A 403 050 07 33 A 442 050 03 33 A 442 055 00 20	<b>20 1003 40012</b> (4)
(3) nur 2-Ventiler/only 2 valves version/seulement 2 soupapes/sólo sistemas de 2 válvulas/заменяемо 2 Клапаны						
(4) mit Einstellschraube/with adjusting screw/avec vis de réglage/con tornillo de ajuste/c установочным ВИНТОМ						

## 432 128

**OM 440 Euro 1**
**986, 989**

11.1991 →

 D (LA) 8 14618 cm<sup>3</sup> 2V 280-320 kW (381-435 PS) 16,75:1 142,00 mm

94 331 7..

IN [1]	59,0 x 12 x 142,5	A/S - Cr -	- 30° - -	5 - III	A 403 053 09 01 A 422 050 00 26 A 422 050 02 26 A 422 050 05 26 A 422 053 01 01 A 423 050 00 26 A 442 050 02 26 A 442 050 03 26	<b>16117</b>
IN [1]	59,0 x 12 x 142,5	A/S - Cr -	- 30° - -	5 - III	A 442 050 05 26	<b>16146</b>
EX [1]	51,0 x 12 x 142,5	RA/S- Cr -	- 45° - -	5 - III	A 422 050 01 27 A 422 050 02 27 A 442 050 01 27 A 442 050 02 27 A 442 050 03 27 A 442 050 04 27	<b>16150</b>
[50]	∅ 12 mm				A 422 053 00 26	<b>LK-1610</b>
IN/EX [6]	18,03 x 12 x 67,0	G2			A 422 053 04 30	<b>81-16100</b>
IN [2]	60,11 x 51.2 x 8,4	G1 30°			A 422 053 05 31	<b>92-16151</b>
IN [1]	60,31 x 51.2 x 8,6	G1 30°			A 422 053 06 31	<b>92-16152</b>
EX [2]	53,11 x 43 x 9,2	G1 45°			A 442 053 00 32	<b>92-16127</b>
EX [1]	53,11 x 43 x 9,2	G1 45°			A 422 053 01 32	<b>92-16126</b>
EX [1]	53,31 x 43 x 9,4	G1 45°			A 442 053 01 32	<b>92-16149</b>
EX [1]	53,51 x 43.2 x 9,6	G1 45°			A 442 053 02 32	<b>92-16128</b>
	724 mm				A 402 050 21 01 A 402 050 25 01 A 442 050 17 01	<b>20 1003 40201</b>
[12]	M 32 x 76 x 20				A 422 050 03 25 A 476 050 00 25	<b>20 1003 44000</b> (1)
[12]	M 32 x 76 x 20				A 422 050 03 25 A 476 050 00 25	<b>20 1003 44001</b> (2)
(1) OES specification						

Fortsetzung nächste Seite / continued on next page / suite page suivante / continuación página próxima / Продолжение на следующей странице

					Reference	Item No.
(2)	IAM specification					
[4]					A 403 050 07 33	20 1002 25010 (3)
[1]					A 442 050 03 33	
[1]					A 403 050 03 33	20 1003 40010
					A 403 050 07 33	
					A 442 050 03 33	20 1003 40012 (4)
					A 403 050 03 33	
					A 403 050 07 33	
					A 442 050 03 33	
					A 442 055 00 20	
(3)	nur 2-Ventiler/only 2 valves version/seulement 2 soupapes/sólo sistemas de 2 válvulas/заменяемо 2 Клапаны					
(4)	mit Einstellschraube/with adjusting screw/avec vis de réglage/con tornillo de ajuste/c установочным винтом					
	- - G - S -	- - -			A 402 010 03 20	20 0803 40300
					A 403 010 40 20	
					A 403 010 89 20	
					A 427 010 00 20	
					A 427 010 10 20	
					A 429 010 02 20	
					A 442 010 07 20	
	- V - G - S -	- - -	ready-to-install		A 427 010 10 20	20 0803 40301

## 433 128

OM 440 Euro 1

948

12.1991→

D (A)

8

14618 cm<sup>3</sup> 2V

269 kW

(366 PS) 18:1

142,00 mm

IN [1]	59,0 x 12 x 142,5	A/S - Cr -	- 30° -	-	5 - III	A 403 053 09 01 A 422 050 00 26 A 422 050 02 26 A 422 050 05 26 A 422 053 01 01 A 423 050 00 26 A 442 050 02 26 A 442 050 03 26	16117
IN [1]	59,0 x 12 x 142,5	A/S - Cr -	- 30° -	-	5 - III	A 442 050 05 26	16146
EX [1]	51,0 x 12 x 142,5	RA/S- Cr -	- 45° -	-	5 - III	A 422 050 01 27 A 422 050 02 27 A 442 050 01 27 A 442 050 02 27 A 442 050 03 27 A 442 050 04 27	16150
[50]	Ø 12 mm					A 422 053 00 26	LK-1610
IN/EX [6]	18,03 x 12 x 67,0	G2				A 422 053 04 30	81-16100

Fortsetzung nächste Seite / continued on next page / suite page suivante / continuación página próxima / Продолжение на следующей странице

					Reference	Item No.
	IN [2]	60,11 x 51.2 x 8,4	G1 30°		A 422 053 05 31	<b>92-16151</b>
	IN [1]	60,31 x 51.2 x 8,6	G1 30°		A 422 053 06 31	<b>92-16152</b>
	EX [2]	53,11 x 43 x 9,2	G1 45°		A 442 053 00 32	<b>92-16127</b>
	EX [1]	53,11 x 43 x 9,2	G1 45°		A 422 053 01 32	<b>92-16126</b>
	EX [1]	53,31 x 43 x 9,4	G1 45°		A 442 053 01 32	<b>92-16149</b>
	EX [1]	53,51 x 43.2 x 9,6	G1 45°		A 442 053 02 32	<b>92-16128</b>
	724 mm				A 422 050 00 01 A 422 050 04 01 A 422 050 10 01 A 422 050 22 01	<b>20 1003 42201</b>
	[12]  (1) OES specification	M 32 x 76 x 20			A 422 050 03 25 A 476 050 00 25	<b>20 1003 44000</b> (1)
	[4]				A 403 050 07 33 A 442 050 03 33	<b>20 1002 25010</b> (2)
	[1]				A 403 050 03 33 A 403 050 07 33 A 442 050 03 33	<b>20 1003 40010</b>
	[1]				A 403 050 03 33 A 403 050 07 33 A 442 050 03 33 A 442 055 00 20	<b>20 1003 40012</b> (3)
	(2) nur 2-Ventiler/only 2 valves version/seulement 2 soupapes/sólo sistemas de 2 válvulas/заменяемо 2 Клапаны					
	(3) mit Einstellschraube/with adjusting screw/avec vis de réglage/con tornillo de ajuste/c установочным ВИНТОМ					

**434**
**128**
**OM 482**
**940 - 941**

12.1991 →

D (A)

8

 14618 cm<sup>3</sup> 2V

269 kW

(366 PS) 16,25:1 142,00 mm

93 484 6.., 93 484 7..

	IN [1]	59,0 x 12 x 142,5	A/S - Cr -	- 30° - -	5 - III	A 403 053 09 01 A 422 050 00 26 A 422 050 02 26 A 422 050 05 26 A 422 053 01 01 A 423 050 00 26 A 442 050 02 26 A 442 050 03 26	<b>16117</b>
	IN [1] EX [1]	59,0 x 12 x 142,5 51,0 x 12 x 142,5	A/S - Cr - RA/S- Cr -	- 30° - - - 45° - -	5 - III 5 - III	A 442 050 05 26 A 422 050 01 27 A 422 050 02 27 A 442 050 01 27 A 442 050 02 27 A 442 050 03 27 A 442 050 04 27	<b>16146</b> <b>16150</b>
	[50]	∅ 12 mm				A 422 053 00 26	<b>LK-1610</b>
	IN/EX [6]	18,03 x 12 x 67,0	G2			A 422 053 04 30	<b>81-16100</b>
	IN [2]	60,11 x 51.2 x 8,4	G1 30°			A 422 053 05 31	<b>92-16151</b>
	IN [1]	60,31 x 51.2 x 8,6	G1 30°			A 422 053 06 31	<b>92-16152</b>
	EX [2]	53,11 x 43 x 9,2	G1 45°			A 442 053 00 32	<b>92-16127</b>
	EX [1]	53,11 x 43 x 9,2	G1 45°			A 422 053 01 32	<b>92-16126</b>
	EX [1]	53,31 x 43 x 9,4	G1 45°			A 442 053 01 32	<b>92-16149</b>
	EX [1]	53,51 x 43.2 x 9,6	G1 45°			A 442 053 02 32	<b>92-16128</b>

Fortsetzung nächste Seite / continued on next page / suite page suivante / continuación página próxima / Продолжение на следующей странице

					Reference	Item No.
	724 mm				A 422 050 00 01 A 422 050 04 01 A 422 050 10 01 A 422 050 22 01	<b>20 1003 42201</b>
[12]	M 32 x 76 x 20				A 422 050 03 25 A 476 050 00 25	<b>20 1003 44000</b> (1)
	(1) OES specification					
[1]					A 403 050 03 33 A 403 050 07 33 A 442 050 03 33	<b>20 1003 40010</b>
[1]					A 403 050 03 33 A 403 050 07 33 A 442 050 03 33 A 442 055 00 20	<b>20 1003 40012</b> (2)
	(2) mit Einstellschraube/with adjusting screw/avec vis de réglage/con tornillo de ajuste/c установочным винтом					
	- - G - S -	- - -			A 402 010 03 20 A 403 010 40 20 A 403 010 89 20 A 427 010 00 20 A 427 010 10 20 A 429 010 02 20 A 442 010 07 20	<b>20 0803 40300</b>
	- V - G - S -	- - -	ready-to-install		A 427 010 10 20	<b>20 0803 40301</b>

## 435 128

OM 447 Euro 1 901-204 1992→ D 6 11970 cm<sup>3</sup> 2V 155,00 mm

IN [1]	59,0 x 12 x 142,5	A/S - Cr -	- 30° - -	5 - III	A 403 053 09 01 A 422 050 00 26 A 422 050 02 26 A 422 050 05 26 A 422 053 01 01 A 423 050 00 26 A 442 050 02 26 A 442 050 03 26	<b>16117</b>
IN [1]	59,0 x 12 x 142,5	A/S - Cr -	- 30° - -	5 - III	A 442 050 05 26	<b>16146</b>
EX [1]	51,0 x 12 x 142,5	A/S - Cr -	- 45° - -	5 - III	A 422 050 00 27	<b>16116</b>
EX [1]	51,0 x 12 x 142,5	RA/S- Cr -	- 45° - -	5 - III	A 422 050 01 27 A 422 050 02 27 A 442 050 01 27 A 442 050 02 27 A 442 050 03 27 A 442 050 04 27	<b>16150</b>
[50]	Ø 12 mm				A 422 053 00 26	<b>LK-1610</b>

Fortsetzung nächste Seite / continued on next page / suite page suivante / continuación página próxima / Продолжение на следующей странице



					Reference	Item No.
	IN/EX [6]	18,03 x 12 x 67,0	G2		A 422 053 04 30	<b>81-16100</b>
	IN [2]	60,11 x 51.2 x 8,4	G1 30°		A 422 053 05 31	<b>92-16151</b>
	IN [1]	60,31 x 51.2 x 8,6	G1 30°		A 422 053 06 31	<b>92-16152</b>
	EX [2]	53,11 x 43 x 9,2	G1 45°		A 442 053 00 32	<b>92-16127</b>
	EX [1]	53,11 x 43 x 9,2	G1 45°		A 422 053 01 32	<b>92-16126</b>
	EX [1]	53,31 x 43 x 9,4	G1 45°		A 442 053 01 32	<b>92-16149</b>
	EX [1]	53,51 x 43.2 x 9,6	G1 45°		A 442 053 02 32	<b>92-16128</b>
	[12]	M 31,5 x 76,5 x 20			A 403 054 09 01 A 403 054 18 01	<b>20 1003 40060</b>
	[12]	M 32 x 76 x 20			A 422 050 03 25 A 476 050 00 25	<b>20 1003 44000</b> (1)
	[12]	M 32 x 76 x 20			A 422 050 03 25 A 476 050 00 25	<b>20 1003 44001</b> <b>NEW</b> (2)
	(1)	OES specification				
	(2)	IAM specification				
	[4]				A 403 050 07 33 A 442 050 03 33	<b>20 1002 25010</b> (3)
	[1]				A 403 050 03 33 A 403 050 07 33	<b>20 1003 40010</b>
	[1]				A 442 050 03 33 A 403 050 03 33 A 403 050 07 33 A 442 050 03 33 A 442 055 00 20	<b>20 1003 40012</b> (4)
	(3)	nur 2-Ventiler/only 2 valves version/seulement 2 soupapes/sólo sistemas de 2 válvulas/заменяемо 2 Клапаны				
	(4)	mit Einstellschraube/with adjusting screw/avec vis de réglage/con tornillo de ajuste/с установочным ВИНТОМ				

## 436 128

OM 446 Euro 2

940 - 943, 945 - 946, 948

07.1992 →

D (LA)

8

14618 cm<sup>3</sup> 2V

320-390 kW

(435-530 PS)

17,25:1 142,00 mm

94 681 6..

	IN [1]	59,0 x 12 x 142,5	A/S - Cr -	- 30° -	-	5 - III	A 403 053 09 01 A 422 050 00 26 A 422 050 02 26 A 422 050 05 26 A 422 053 01 01 A 423 050 00 26 A 442 050 02 26 A 442 050 03 26	<b>16117</b>
	IN [1]	59,0 x 12 x 142,5	A/S - Cr -	- 30° -	-	5 - III	A 442 050 05 26	<b>16146</b>
	EX [2]	17,1 x 8 x 90,3	A - -	- 45° -	-	1 -	A 442 016 02 91 A 442 016 03 91	<b>50 004 665</b> (1)
	EX [1]	51,0 x 12 x 142,5	RA/S- Cr -	- 45° -	-	5 - III	A 422 050 01 27 A 422 050 02 27 A 442 050 01 27 A 442 050 02 27 A 442 050 03 27 A 442 050 04 27	<b>16150</b>
	(1)	Konstantdrosselventil - Dom Exhaust brake valve - dome Papillon constant - Dôme Válvula de estrangulamiento constante - Dom Нерегулируемый дроссельный клапан - собор						
	[50]	Ø 12 mm					A 422 053 00 26	<b>LK-1610</b>

Fortsetzung nächste Seite / continued on next page / suite page suivante / continuación página próxima / Продолжение на следующей странице

					Reference	Item No.
	IN/EX [6] 18,03 x 12 x 67,0	G2			A 422 053 04 30	81-16100
	IN [2] 60,11 x 51.2 x 8,4	G1 45°			A 442 053 05 31	92-16122
	IN [1] 60,51 x 51.2 x 8,9	G1 30°			A 442 053 07 31	92-16123
	EX [2] 53,11 x 43 x 9,2	G1 45°			A 442 053 00 32	92-16127
	EX [1] 53,11 x 43 x 9,2	G1 45°			A 422 053 01 32	92-16126
	EX [1] 53,31 x 43 x 9,4	G1 45°			A 442 053 01 32	92-16149
	EX [1] 53,51 x 43.2 x 9,6	G1 45°			A 442 053 02 32	92-16128
	724 mm				A 442 050 08 01 A 442 050 11 01	20 1003 44201
	[12] M 32 x 76 x 20				A 422 050 03 25 A 476 050 00 25	20 1003 44000 (2)
	[12] M 32 x 76 x 20				A 422 050 03 25 A 476 050 00 25	20 1003 44001 <sup>NEW</sup> (3)
	(2) OES specification					
	(3) IAM specification					
	[4]				A 403 050 07 33 A 442 050 03 33	20 1002 25010 (4)
	[1]				A 403 050 03 33 A 403 050 07 33 A 442 050 03 33	20 1003 40010
	[1]				A 403 050 03 33 A 403 050 07 33 A 442 050 03 33 A 442 055 00 20	20 1003 40012 (5)
	(4) nur 2-Ventiler/only 2 valves version/seulement 2 soupapes/sólo sistemas de 2 válvulas/заменяемо 2 Клапаны					
	(5) mit Einstellschraube/with adjusting screw/avec vis de réglage/con tornillo de ajuste/c установочным винтом					
	- V - G - S -	- - - EVB	ready-to-install		A 442 010 06 20	20 0803 44000
	- - G - S -	- - -			A 442 010 06 20	20 0803 44010

## 437 128

<b>OM 457 Euro 2</b>	<b>936, 938 - 939</b>								
	08.1998 →	D (LA)	6	11967 cm <sup>3</sup>	4V	260-300 kW	(354-408 PS)	17,25:1	155,00 mm
<b>OM 457 Euro 2/3</b>	<b>933 - 934, 940</b>								
	09.1992 →	D (LA)	6	11967 cm <sup>3</sup>	4V	220-315 kW	(299-428 PS)	17,25:1	155,00 mm

97 411 7..

Fortsetzung nächste Seite / continued on next page / suite page suivante / continuación página próxima / Продолжение на следующей странице

					Reference	Item No.
	IN [2] 45,5 x 9 x 144,9	RA/S- Cr -	- 30° - -	5 - III	A 457 053 00 01 A 541 050 02 26	<b>160054</b>
	IN [2] 45,5 x 9 x 145,0 M + 1	S - Cr -	- 30° - -	5 - III	A 460 053 00 01 A 541 053 01 01	<b>16204</b>
	EX [2] 17,0 x 8 x 87,0	A - -	- 45° - -	9 -	A 541 016 05 91 A 541 016 06 91 A 541 016 07 91	<b>261101</b> (1)
	EX [2] 41,0 x 9 x 145,0	RA/S- Cr -	- 45° - -	5 - III	A 541 050 01 27 A 541 050 02 27	<b>160055</b>
	EX [2] 42,1 x 9 x 145,0	RA/S- Cr -	- 36° - -	5 - III	A 457 050 03 27 A 457 050 05 27	<b>16205</b>
	(1) Konstantdrosselventil - flach Exhaust brake valve - flat Soupape de réduction permanente - plate Válvula de reducción permanente - plana Постоянный дроссельный клапан					
	[50] Ø 9 mm				A 541 053 00 26 A 541 053 01 26 A 541 053 02 26	<b>LK-2615</b>
	IN/EX [4] 15,03 x 9 x 61,0	G2			A 457 053 12 30 A 541 053 12 30 A 541 053 27 30	<b>81-16103</b> (2)
	IN/EX [4] 15,24 x 9 x 61,0	G2			A 457 053 13 30 A 541 053 13 30 A 541 053 28 30	<b>81-16104</b> (2)
	(2) abweichend zu OE Bohrung fertigbearbeitet finish-machined with other than original bore usiné à un alésage différent de l'origine orificio mecanizado de manera diferente al original в отличие от OE отверстие расточено					
	IN [2] 47,38 x 40 x 7,7	G1 30°			A 541 053 17 31 A 541 053 21 31 A 541 053 26 31	<b>92-16157</b>
	IN [2] 47,39 x 36.6 x 7,8	G1 30°			A 457 053 16 31	<b>92-16156</b>
	EX [2] 43,10 x 34 x 8,0	G1 45°			A 541 053 05 32	<b>92-16158</b>
	1053 mm				A 457 050 13 01	<b>20 1003 45700</b>
	[12] M 30 x 75				A 541 050 03 22 A 541 050 05 22 A 541 050 07 22 A 541 050 13 22	<b>20 1003 50060</b> (3)
	[12] M 30 x 75				A 541 050 17 22 A 541 050 20 22	<b>20 1003 50062</b> <span style="border: 1px solid black; padding: 2px;">NEW</span> (4)
	(3) Rollenstößel/roller tappet/poussoir à galet/empujador de rodillos/поликовый толкатель					
	(4) Mit 2 Ölbohrungen/with 2 oil holes/avec 2 trous d'huile/con 2 agujeros de aceite/c 2-мя смазочными отверстиями					
	I [1]				A 541 050 04 33 A 541 050 06 33 A 541 050 07 33 A 541 050 08 33 A 541 050 09 33 A 541 055 07 50	<b>20 1003 50010</b> (5)
	[1]				A 541 050 05 34 A 541 050 06 34 A 541 050 07 34 A 541 050 08 34	<b>20 1003 50011</b>
	(5) IN					

M

					Reference	Item No.	
<b>438</b>		<b>128</b>	<b>OM 445 Euro 2 923</b> 01.1994 → 09.1996 D (LA) 6 10964 cm <sup>3</sup> 2V 250 kW (340 PS) 17,25:1 142,00 mm 94 681 6..				
	IN [1]	59,0 x 12 x 142,5	A/S - Cr -	- 30° - -	5 - III	A 403 053 09 01 A 422 050 00 26 A 422 050 02 26 A 422 050 05 26 A 422 053 01 01 A 423 050 00 26 A 442 050 02 26 A 442 050 03 26	<b>16117</b>
	IN [1]	59,0 x 12 x 142,5	A/S - Cr -	- 30° - -	5 - III	A 442 050 05 26	<b>16146</b>
	EX [2]	17,1 x 8 x 90,3	A - -	- 45° - -	1 -	A 442 016 02 91 A 442 016 03 91	<b>50 004 665</b> (1)
	EX [1]	51,0 x 12 x 142,5	RA/S- Cr -	- 45° - -	5 - III	A 422 050 01 27 A 422 050 02 27 A 442 050 01 27 A 442 050 02 27 A 442 050 03 27 A 442 050 04 27	<b>16150</b>
	(1)	Konstantdrosselventil - Dom Exhaust brake valve - dome Papillon constant - Dôme Válvula de estrangulamiento constante - Dom Нерегулируемый дроссельный клапан - собор					
	[50]	Ø 12 mm				A 422 053 00 26	<b>LK-1610</b>
	IN/EX [6]	18,03 x 12 x 67,0	G2			A 422 053 04 30	<b>81-16100</b>
	IN [2]	60,11 x 51.2 x 8,4	G1 45°			A 442 053 05 31	<b>92-16122</b>
	IN [1]	60,51 x 51.2 x 8,9	G1 30°			A 442 053 07 31	<b>92-16123</b>
	EX [2]	53,11 x 43 x 9,2	G1 45°			A 442 053 00 32	<b>92-16127</b>
	EX [1]	53,11 x 43 x 9,2	G1 45°			A 422 053 01 32	<b>92-16126</b>
	EX [1]	53,31 x 43 x 9,4	G1 45°			A 442 053 01 32	<b>92-16149</b>
	EX [1]	53,51 x 43.2 x 9,6	G1 45°			A 442 053 02 32	<b>92-16128</b>
	[12]	M 31,5 x 76,5 x 20				A 403 054 09 01 A 403 054 18 01	<b>20 1003 40060</b>
	[12]	M 32 x 76 x 20				A 422 050 03 25 A 476 050 00 25	<b>20 1003 44000</b> (2)
	[12]	M 32 x 76 x 20				A 422 050 03 25 A 476 050 00 25	<b>20 1003 44001</b> <span style="border: 1px solid black; padding: 1px;">NEW</span> (3)
	(2)	OES specification					
	(3)	IAM specification					
	[4]					A 403 050 07 33 A 442 050 03 33	<b>20 1002 25010</b> (4)
	[1]					A 403 050 03 33 A 403 050 07 33 A 442 050 03 33	<b>20 1003 40010</b>
	[1]					A 403 050 03 33 A 403 050 07 33 A 442 050 03 33 A 442 055 00 20	<b>20 1003 40012</b> (5)
	(4)	nur 2-Ventiler/only 2 valves version/seulement 2 soupapes/sólo sistemas de 2 válvulas/заменяемо 2 Клапаны					
	(5)	mit Einstellschraube/with adjusting screw/avec vis de réglage/con tornillo de ajuste/c установочным винтом					
Fortsetzung nächste Seite / continued on next page / suite page suivante / continuación página próxima / Продолжение на следующей странице							

M

					Reference	Item No.
	- - G - S -	- - -			A 442 010 06 20	20 0803 44010

## 439 128

<b>OM 446 Euro 2</b>	<b>920, 922, 924 - 931, 935 - 936, 939</b>								
	01.1994 →	D (LA)	8	14618 cm <sup>3</sup>	2V	280-390 kW	(381-530 PS)	17,25:1	142,00 mm
<b>OM 446 Euro 2</b>	<b>934, 938</b>								
	09.1994 →	D (A)	8	14618 cm <sup>3</sup>	2V	280 kW	(381 PS)	17,25:1	142,00 mm

94 681 6..

	IN [1]	59,0 x 12 x 142,5	A/S - Cr -	- 30° -	-	5 - III	A 403 053 09 01 A 422 050 00 26 A 422 050 02 26 A 422 050 05 26 A 422 053 01 01 A 423 050 00 26 A 442 050 02 26 A 442 050 03 26	<b>16117</b>
	IN [1]	59,0 x 12 x 142,5	A/S - Cr -	- 30° -	-	5 - III	A 442 050 05 26	<b>16146</b>
	EX [2]	17,1 x 8 x 90,3	A - -	- 45° -	-	1 -	A 442 016 02 91 A 442 016 03 91	<b>50 004 665</b> (1)
	EX [1]	51,0 x 12 x 142,5	RA/S- Cr -	- 45° -	-	5 - III	A 422 050 01 27 A 422 050 02 27 A 442 050 01 27 A 442 050 02 27 A 442 050 03 27 A 442 050 04 27	<b>16150</b>
	(1)	Konstantdrosselventil - Dom Exhaust brake valve - dome Papillon constant - Dôme Válvula de estrangulamiento constante - Dom Нерегулируемый дроссельный клапан - собор						
	[50]	Ø 12 mm					A 422 053 00 26	<b>LK-1610</b>
	IN/EX [6]	18,03 x 12 x 67,0	G2				A 422 053 04 30	<b>81-16100</b>
	IN [2]	60,11 x 51.2 x 8,4	G1 45°				A 442 053 05 31	<b>92-16122</b>
	IN [1]	60,51 x 51.2 x 8,9	G1 30°				A 442 053 07 31	<b>92-16123</b>
	EX [2]	53,11 x 43 x 9,2	G1 45°				A 442 053 00 32	<b>92-16127</b>
	EX [1]	53,11 x 43 x 9,2	G1 45°				A 422 053 01 32	<b>92-16126</b>
	EX [1]	53,31 x 43 x 9,4	G1 45°				A 442 053 01 32	<b>92-16149</b>
	EX [1]	53,51 x 43.2 x 9,6	G1 45°				A 442 053 02 32	<b>92-16128</b>
		724 mm					A 442 050 08 01 A 442 050 11 01	<b>20 1003 44201</b>
	[12]	M 31,5 x 76,5 x 20					A 403 054 09 01 A 403 054 18 01	<b>20 1003 40060</b>
	[12]	M 32 x 76 x 20					A 422 050 03 25 A 476 050 00 25	<b>20 1003 44000</b> (2)
	[12]	M 32 x 76 x 20					A 422 050 03 25 A 476 050 00 25	<b>20 1003 44001</b> <b>NEW</b> (3)
	(2)	OES specification						
	(3)	IAM specification						

Fortsetzung nächste Seite / continued on next page / suite page suivante / continuación página próxima / Продолжение на следующей странице



					Reference	Item No.
[4]					A 403 050 07 33	20 1002 25010 (4)
[1]					A 442 050 03 33	20 1003 40010
[1]					A 403 050 03 33	
					A 403 050 07 33	20 1003 40012 (5)
					A 442 050 03 33	
					A 403 050 07 33	
					A 442 050 03 33	
					A 442 055 00 20	
(4)	nur 2-Ventiler/only 2 valves version/seulement 2 soupapes/sólo sistemas de 2 válvulas/заменяемо 2 Клапаны					
(5)	mit Einstellschraube/with adjusting screw/avec vis de réglage/con tornillo de ajuste/c установочным винтом					
	- V - G - S -	- - - EVB	ready-to-install		A 442 010 06 20	20 0803 44000
	- - G - S -	- - -			A 442 010 06 20	20 0803 44010

## 440 128

OM 457 Euro 3

924 - 925, 928, 931

01.1994 →

D (LA) 6

11967 cm<sup>3</sup>

4V

265-280 kW

(360-381 PS)

17,25:1

155,00 mm

40 742 6..., 99 948 6..

	IN [2]	45,5 x 9 x 144,9	RA/S- Cr -	- 30° -	-	5 - III	A 457 053 00 01	160054
	IN [2]	45,5 x 9 x 145,0	S - Cr -	- 30° -	-	5 - III	A 541 050 02 26	16204
	EX [2]	17,0 x 8 x 87,0	A - -	- 45° -	-	9 -	A 460 053 00 01	261101 (1)
							A 541 053 01 01	
							A 541 016 05 91	
	EX [2]	41,0 x 9 x 145,0	RA/S- Cr -	- 45° -	-	5 - III	A 541 016 06 91	160055
	EX [2]	42,1 x 9 x 145,0	RA/S- Cr -	- 36° -	-	5 - III	A 541 016 07 91	16205
							A 541 050 01 27	
							A 541 050 02 27	
	(1)	Konstantdrosselventil - flach Exhaust brake valve - flat Soupape de réduction permanente - plate Válvula de reducción permanente - plana Постоянный дроссельный клапан						
	[50]	Ø 9 mm					A 457 050 03 27	LK-2615
							A 541 053 00 26	
							A 541 053 01 26	
							A 541 053 02 26	
	IN/EX [4]	15,03 x 9 x 61,0	G2				A 541 053 12 30	81-16103 (2)
							A 541 053 12 30	
							A 541 053 27 30	
	IN/EX [4]	15,24 x 9 x 61,0	G2				A 457 053 13 30	81-16104 (2)
							A 541 053 13 30	
							A 541 053 28 30	

Fortsetzung nächste Seite / continued on next page / suite page suivante / continuación página próxima / Продолжение на следующей странице

					Reference	Item No.
	(2) abweichend zu OE Bohrung fertigbearbeitet finish-machined with other than original bore usiné à un alésage différent de l'origine orificio mecanizado de manera diferente al original в отличие от OE отверстие расточено					
	IN [2] 47,38 x 40 x 7,7	G1 30°			A 541 053 17 31 A 541 053 21 31 A 541 053 26 31	<b>92-16157</b>
	IN [2] 47,39 x 36.6 x 7,8	G1 30°			A 457 053 16 31	<b>92-16156</b>
	EX [2] 43,10 x 34 x 8,0	G1 45°			A 541 053 05 32	<b>92-16158</b>
	1053 mm				A 457 050 13 01 A 457 050 25 01	<b>20 1003 45700</b> <b>20 1003 45701</b> (3)
	(3) Zähnezahl 73 gear z=73 Nombre de dents 73 Número des dientes 73 число зубьев 73					
	[12] M 30 x 75				A 541 050 03 22 A 541 050 05 22 A 541 050 07 22 A 541 050 13 22	<b>20 1003 50060</b> (4)
	(4) Rollenstößel/roller tappet/poussoir à galet/empujador de rodillos/роликовый толкатель					
	I [1]				A 541 050 04 33 A 541 050 06 33 A 541 050 07 33 A 541 050 08 33 A 541 050 09 33 A 541 055 07 50	<b>20 1003 50010</b> (5)
	[1]				A 541 050 05 34 A 541 050 06 34 A 541 050 07 34 A 541 050 08 34	<b>20 1003 50011</b>
	(5) IN					

**441**
**128**
**OM 457 Euro 3**
**914**

D (LA) 6 11967 cm<sup>3</sup> 4V 250 kW (340 PS) 17,25:1 155,00 mm

99 948 6..

	IN [2] 45,5 x 9 x 144,9	RA/S- Cr -	- 30° - -	5 - III	A 457 053 00 01 A 541 050 02 26	<b>160054</b>
	IN [2] 45,5 x 9 x 145,0	S - Cr -	- 30° - -	5 - III	A 460 053 00 01 A 541 053 01 01	<b>16204</b>
	EX [2] 17,0 x 8 x 87,0	A - -	- 45° - -	9 -	A 541 016 05 91 A 541 016 06 91 A 541 016 07 91	<b>261101</b> (1)
	EX [2] 41,0 x 9 x 145,0	RA/S- Cr -	- 45° - -	5 - III	A 541 050 01 27 A 541 050 02 27	<b>160055</b>
	EX [2] 42,1 x 9 x 145,0	RA/S- Cr -	- 36° - -	5 - III	A 457 050 03 27 A 457 050 05 27	<b>16205</b>
	(1) Konstantdrosselventil - flach Exhaust brake valve - flat Soupape de réduction permanente - plate Válvula de reducción permanente - plana Постоянный дроссельный клапан					
	[50] Ø 9 mm				A 541 053 00 26 A 541 053 01 26 A 541 053 02 26	<b>LK-2615</b>

Fortsetzung nächste Seite / continued on next page / suite page suivante / continuación página próxima / Продолжение на следующей странице

					Reference	Item No.
	IN/EX [4] 15,03 x 9 x 61,0	G2			A 457 053 12 30 A 541 053 12 30 A 541 053 27 30	<b>81-16103</b> (2)
	IN/EX [4] 15,24 x 9 x 61,0	G2			A 457 053 13 30 A 541 053 13 30 A 541 053 28 30	<b>81-16104</b> (2)
	(2) abweichend zu OE Bohrung fertigbearbeitet finish-machined with other than original bore usiné à un alésage différent de l'origine orificio mecanizado de manera diferente al original в отличие от OE отверстия расточено					
	IN [2] 47,38 x 40 x 7,7	G1 30°			A 541 053 17 31 A 541 053 21 31 A 541 053 26 31	<b>92-16157</b>
	IN [2] 47,39 x 36.6 x 7,8	G1 30°			A 457 053 16 31	<b>92-16156</b>
	EX [2] 43,10 x 34 x 8,0	G1 45°			A 541 053 05 32	<b>92-16158</b>
	EX [1] 43,10 x 34.4 x 7,8	G1 36°			A 457 053 13 32	<b>92-16170</b>
	1053 mm				A 457 050 25 01 A 457 050 31 01	<b>20 1003 45701</b> (3) <b>20 1003 45704</b>
	(3) Zähnezahl 73 gear z=73 Nombre de dents 73 Número des dientes 73 число зубьев 73					
	[12] M 30 x 75				A 541 050 03 22 A 541 050 05 22 A 541 050 07 22 A 541 050 13 22	<b>20 1003 50060</b> (4)
	(4) Rollenstößel/roller tappet/poussoir à galet/empujador de rodillos/роликовый толкатель					
	I [1]				A 541 050 04 33 A 541 050 06 33 A 541 050 07 33 A 541 050 08 33 A 541 050 09 33 A 541 055 07 50	<b>20 1003 50010</b> (5)
	[1]				A 541 050 05 34 A 541 050 06 34 A 541 050 07 34 A 541 050 08 34	<b>20 1003 50011</b>
	(5) IN					

## 442 128

**OM 457 Euro 3** **926**  
10.1995 → D (LA) 6 11967 cm<sup>3</sup> 4V 265 kW (360 PS) 17,25:1 155,00 mm  
40 742 6.., 99 948 6..

	IN [2] 45,5 x 9 x 144,9	RA/S- Cr -	- 30° - -	5 - III	A 457 053 00 01 A 541 050 02 26	<b>160054</b>
	IN [2] 45,5 x 9 x 145,0	S - Cr -	- 30° - -	5 - III	A 460 053 00 01 A 541 053 01 01	<b>16204</b>
	EX [2] 17,0 x 8 x 87,0	A - -	- 45° - -	9 -	A 541 016 05 91 A 541 016 06 91 A 541 016 07 91	<b>261101</b> (1)
	EX [2] 41,0 x 9 x 145,0	RA/S- Cr -	- 45° - -	5 - III	A 541 050 01 27 A 541 050 02 27	<b>160055</b>
	EX [2] 42,1 x 9 x 145,0	RA/S- Cr -	- 36° - -	5 - III	A 457 050 03 27 A 457 050 05 27	<b>16205</b>
	(1) Konstantdrosselventil - flach Exhaust brake valve - flat Soupape de réduction permanente - plate Válvula de reducción permanente - plana Постоянный дроссельный клапан					

Fortsetzung nächste Seite / continued on next page / suite page suivante / continuación página próxima / Продолжение на следующей странице

					Reference	Item No.
[50]	Ø 9 mm				A 541 053 00 26 A 541 053 01 26 A 541 053 02 26	<b>LK-2615</b>
IN/EX [4]	15,03 x 9 x 61,0	G2			A 457 053 12 30 A 541 053 12 30 A 541 053 27 30	<b>81-16103</b> (2)
IN/EX [4]	15,24 x 9 x 61,0	G2			A 457 053 13 30 A 541 053 13 30 A 541 053 28 30	<b>81-16104</b> (2)
	(2) abweichend zu OE Bohrung fertigbearbeitet finish-machined with other than original bore usiné à un alésage différent de l'origine orificio mecanizado de manera diferente al original в отличие от OE отверстие расточено					
IN [2]	47,38 x 40 x 7,7	G1 30°			A 541 053 17 31 A 541 053 21 31 A 541 053 26 31	<b>92-16157</b>
EX [2]	43,10 x 34 x 8,0	G1 45°			A 541 053 05 32	<b>92-16158</b>
[12]	M 30 x 75				A 541 050 03 22 A 541 050 05 22 A 541 050 07 22 A 541 050 13 22	<b>20 1003 50060</b> (3)
	(3) Rollenstößel/roller tappet/poussoir à galet/empujador de rodillos/роликовый толкатель					
I [1]					A 541 050 04 33 A 541 050 06 33 A 541 050 07 33 A 541 050 08 33 A 541 050 09 33 A 541 055 07 50	<b>20 1003 50010</b> (4)
[1]					A 541 050 05 34 A 541 050 06 34 A 541 050 07 34 A 541 050 08 34	<b>20 1003 50011</b>
	(4) IN					

## 443 128

OM 457 Euro 2/3 **935**

D (LA) 6 11967 cm<sup>3</sup> 4V 185 kW (252 PS) 17,25:1 155,00 mm

OM 457 Euro 3 **929**

10.1995 →

D (LA) 6 11967 cm<sup>3</sup> 4V 265 kW (360 PS) 17,25:1 155,00 mm

40 742 6..., 97 411 7..., 99 948 6..

IN [2]	45,5 x 9 x 144,9	RA/S- Cr -	- 30° - -	5 - III	A 457 053 00 01 A 541 050 02 26	<b>160054</b>
IN [2]	45,5 x 9 x 145,0	S - Cr -	- 30° - -	5 - III	A 460 053 00 01 A 541 053 01 01	<b>16204</b>
EX [2]	17,0 x 8 x 87,0	A - -	- 45° - -	9 -	A 541 016 05 91 A 541 016 06 91 A 541 016 07 91	<b>261101</b> (1)
EX [2]	41,0 x 9 x 145,0	RA/S- Cr -	- 45° - -	5 - III	A 541 050 01 27 A 541 050 02 27	<b>160055</b>
EX [2]	42,1 x 9 x 145,0	RA/S- Cr -	- 36° - -	5 - III	A 457 050 03 27 A 457 050 05 27	<b>16205</b>
	(1) Konstantdrosselventil - flach Exhaust brake valve - flat Soupape de réduction permanente - plate Válvula de reducción permanente - plana Постоянный дроссельный клапан					
[50]	Ø 9 mm				A 541 053 00 26 A 541 053 01 26 A 541 053 02 26	<b>LK-2615</b>

Fortsetzung nächste Seite / continued on next page / suite page suivante / continuación página próxima / Продолжение на следующей странице

					Reference	Item No.
	IN/EX [4] 15,03 x 9 x 61,0	G2			A 457 053 12 30 A 541 053 12 30 A 541 053 27 30	<b>81-16103</b> (2)
	IN/EX [4] 15,24 x 9 x 61,0	G2			A 457 053 13 30 A 541 053 13 30 A 541 053 28 30	<b>81-16104</b> (2)
	(2) abweichend zu OE Bohrung fertigbearbeitet finish-machined with other than original bore usiné à un alésage différent de l'origine orificio mecanizado de manera diferente al original в отличие от OE отверстия расточено					
	IN [2] 47,38 x 40 x 7,7	G1 30°			A 541 053 17 31 A 541 053 21 31 A 541 053 26 31	<b>92-16157</b>
	IN [2] 47,39 x 36.6 x 7,8	G1 30°			A 457 053 16 31	<b>92-16156</b>
	EX [2] 43,10 x 34 x 8,0	G1 45°			A 541 053 05 32	<b>92-16158</b>
	1053 mm				A 457 050 13 01	<b>20 1003 45700</b>
	[12] M 30 x 75				A 541 050 03 22 A 541 050 05 22 A 541 050 07 22 A 541 050 13 22	<b>20 1003 50060</b> (3)
	(3) Rollenstößel/roller tappet/poussoir à galet/empujador de rodillos/роликовый толкатель					
	I [1]				A 541 050 04 33 A 541 050 06 33 A 541 050 07 33 A 541 050 08 33 A 541 050 09 33 A 541 055 07 50	<b>20 1003 50010</b> (4)
	[1]				A 541 050 05 34 A 541 050 06 34 A 541 050 07 34 A 541 050 08 34	<b>20 1003 50011</b>
	(4) IN					

## 444 128

OM 446 Euro 2 923 01.1996 → D (LA) 8 14618 cm<sup>3</sup> 2V 320 kW (435 PS) 17,25:1 142,00 mm  
94 681 6..

	IN [1] 59,0 x 12 x 142,5	A/S - Cr -	- 30° - -	5 - III	A 403 053 09 01 A 422 050 00 26 A 422 050 02 26 A 422 050 05 26 A 422 053 01 01 A 423 050 00 26 A 442 050 02 26 A 442 050 03 26	<b>16117</b>
	IN [1] 59,0 x 12 x 142,5	A/S - Cr -	- 30° - -	5 - III	A 442 050 05 26	<b>16146</b>
	EX [2] 17,1 x 8 x 90,3	A - -	- 45° - -	1 -	A 442 016 02 91 A 442 016 03 91	<b>50 004 665</b> (1)
	EX [1] 51,0 x 12 x 142,5	RA/S- Cr -	- 45° - -	5 - III	A 422 050 01 27 A 422 050 02 27 A 442 050 01 27 A 442 050 02 27 A 442 050 03 27 A 442 050 04 27	<b>16150</b>
	(1) Konstantdrosselventil - Dom Exhaust brake valve - dome Papillon constant - Dôme Válvula de estrangulamiento constante - Dom Нерегулируемый дроссельный клапан - собор					

Fortsetzung nächste Seite / continued on next page / suite page suivante / continuación página próxima / Продолжение на следующей странице



					Reference	Item No.
[50]	Ø 12 mm				A 422 053 00 26	LK-1610
IN/EX [6]	18,03 x 12 x 67,0	G2			A 422 053 04 30	81-16100
IN [2] IN [1] EX [2] EX [1] EX [1] EX [1]	60,11 x 51.2 x 8,4 60,51 x 51.2 x 8,9 53,11 x 43 x 9,2 53,11 x 43 x 9,2 53,31 x 43 x 9,4 53,51 x 43.2 x 9,6	G1 45° G1 30° G1 45° G1 45° G1 45° G1 45°			A 442 053 05 31 A 442 053 07 31 A 442 053 00 32 A 422 053 01 32 A 442 053 01 32 A 442 053 02 32	92-16122 92-16123 92-16127 92-16126 92-16149 92-16128
	724 mm				A 442 050 08 01 A 442 050 11 01	20 1003 44201
[12]	M 32 x 76 x 20				A 422 050 03 25 A 476 050 00 25	20 1003 44000 (2)
[12]	M 32 x 76 x 20				A 422 050 03 25 A 476 050 00 25	20 1003 44001 <b>NEW</b> (3)
	(2) OES specification (3) IAM specification					
[4] [1] [1]					A 403 050 07 33 A 442 050 03 33 A 403 050 03 33 A 403 050 07 33 A 442 050 03 33 A 403 050 03 33 A 403 050 07 33 A 442 050 03 33 A 442 055 00 20	20 1002 25010 (4) 20 1003 40010 20 1003 40012 (5)
	(4) nur 2-Ventiler/only 2 valves version/seulement 2 soupapes/sólo sistemas de 2 válvulas/заменяемо 2 Клапаны (5) mit Einstellschraube/with adjusting screw/avec vis de réglage/con tornillo de ajuste/c установочным ВИНТОМ					
	- - G - S -	- - -			A 442 010 06 20	20 0803 44010

M

445

128

OM 475

977

05.1997 →

D (A)

5

9973 cm<sup>3</sup> 2V

205 kW

(279 PS) 16,25:1 155,00 mm

Fortsetzung nächste Seite / continued on next page / suite page suivante / continuación página próxima / Продолжение на следующей странице

					Reference	Item No.
	IN [1] 59,0 x 12 x 142,5	A/S - Cr -	- 30° - -	5 - III	A 403 053 09 01 A 422 050 00 26 A 422 050 02 26 A 422 050 05 26 A 422 053 01 01 A 423 050 00 26 A 442 050 02 26 A 442 050 03 26	<b>16117</b>
	IN [1] EX [2] 17,1 x 8 x 90,3	A/S - Cr - A - -	- 30° - - - 45° - -	5 - III 1 -	A 442 050 05 26 A 442 016 02 91 A 442 016 03 91	<b>16146</b> <b>50 004 665</b> (1)
	EX [1] 51,0 x 12 x 142,5	RA/S- Cr -	- 45° - -	5 - III	A 422 050 01 27 A 422 050 02 27 A 442 050 01 27 A 442 050 02 27 A 442 050 03 27 A 442 050 04 27	<b>16150</b>
	(1) Konstantdrosselventil - Dom Exhaust brake valve - dome Papillon constant - Dôme Válvula de estrangulamiento constante - Dom Нерегулируемый дроссельный клапан - собор					
	[50] Ø 12 mm				A 422 053 00 26	<b>LK-1610</b>
	IN/EX [6] 18,03 x 12 x 67,0	G2			A 422 053 04 30	<b>81-16100</b>
	IN [1] 60,11 x 49.3 x 8,4	G1 30°			A 422 053 01 31 A 447 053 00 31	<b>92-16150</b>
	EX [2] 53,11 x 43 x 9,2	G1 45°			A 442 053 00 32	<b>92-16127</b>
	EX [1] 53,11 x 43 x 9,2	G1 45°			A 422 053 01 32	<b>92-16126</b>
	EX [1] 53,31 x 43 x 9,4	G1 45°			A 442 053 01 32	<b>92-16149</b>
	EX [1] 53,51 x 43.2 x 9,6	G1 45°			A 442 053 02 32	<b>92-16128</b>
	[4]				A 403 050 07 33 A 442 050 03 33	<b>20 1002 25010</b> (2)
	[1]				A 403 050 03 33 A 403 050 07 33 A 442 050 03 33	<b>20 1003 40010</b>
	[1]				A 403 050 03 33 A 403 050 07 33 A 442 050 03 33 A 442 055 00 20	<b>20 1003 40012</b> (3)
	(2) nur 2-Ventiler/only 2 valves version/seulement 2 soupapes/sólo sistemas de 2 válvulas/заменяемо 2 Клапаны					
	(3) mit Einstellschraube/with adjusting screw/avec vis de réglage/con tornillo de ajuste/c установочным винтом					

## 446 128

OM 457 Euro 2/3

**942 - 943**

01.1998 →

D (LA) 6 11967 cm<sup>3</sup> 4V 185-260 kW (252-354 PS) 17,25:1 155,00 mm

OM 457 Euro 3

**955**

D (LA) 6 11967 cm<sup>3</sup> 4V 260-315 kW (354-428 PS) 17,25:1 155,00 mm

97 411 7..

Fortsetzung nächste Seite / continued on next page / suite page suivante / continuación página próxima / Продолжение на следующей странице

					Reference	Item No.
	IN [2] 45,5 x 9 x 144,9	RA/S- Cr -	- 30° - -	5 - III	A 457 053 00 01 A 541 050 02 26	<b>160054</b>
	IN [2] 45,5 x 9 x 145,0 M + 1	S - Cr -	- 30° - -	5 - III	A 460 053 00 01 A 541 053 01 01	<b>16204</b>
	EX [2] 17,0 x 8 x 87,0	A - -	- 45° - -	9 -	A 541 016 05 91 A 541 016 06 91 A 541 016 07 91	<b>261101</b> (1)
	EX [2] 41,0 x 9 x 145,0	RA/S- Cr -	- 45° - -	5 - III	A 541 050 01 27 A 541 050 02 27	<b>160055</b>
	EX [2] 42,1 x 9 x 145,0	RA/S- Cr -	- 36° - -	5 - III	A 457 050 03 27 A 457 050 05 27	<b>16205</b>
	(1) Konstantdrosselventil - flach Exhaust brake valve - flat Soupape de réduction permanente - plate Válvula de reducción permanente - plana Постоянный дроссельный клапан					
	[50] Ø 9 mm				A 541 053 00 26 A 541 053 01 26 A 541 053 02 26	<b>LK-2615</b>
	IN/EX [4] 15,03 x 9 x 61,0	G2			A 457 053 12 30 A 541 053 12 30 A 541 053 27 30	<b>81-16103</b> (2)
	IN/EX [4] 15,24 x 9 x 61,0	G2			A 457 053 13 30 A 541 053 13 30 A 541 053 28 30	<b>81-16104</b> (2)
	(2) abweichend zu OE Bohrung fertigbearbeitet finish-machined with other than original bore usiné à un alésage différent de l'origine orificio mecanizado de manera diferente al original в отличие от OE отверстие расточено					
	IN [2] 47,38 x 40 x 7,7	G1 30°			A 541 053 17 31 A 541 053 21 31 A 541 053 26 31	<b>92-16157</b>
	IN [2] 47,39 x 36.6 x 7,8	G1 30°			A 457 053 16 31	<b>92-16156</b>
	EX [2] 43,10 x 34 x 8,0	G1 45°			A 541 053 05 32	<b>92-16158</b>
	EX [1] 43,10 x 34.4 x 7,8	G1 36°			A 457 053 13 32	<b>92-16170</b> <small>NEW</small>
					A 457 050 23 01 A 457 050 30 01 A 460 050 01 01 A 460 050 04 01	<b>20 1003 46000</b> (3)
	(3) Flanschseite 6 x M10 Gewinde Flange 6x M10 thread La bride - le filet 6x M10 La brida - la rosca 6x M10 Фланцевая страница 6 x M10 резьба					
	[12] M 30 x 75				A 541 050 03 22 A 541 050 05 22 A 541 050 07 22 A 541 050 13 22	<b>20 1003 50060</b> (4)
	[12] M 30 x 75				A 541 050 17 22 A 541 050 20 22	<b>20 1003 50062</b> <small>NEW</small> (5)
	(4) Rollenstößel/roller tappet/poussoir à galet/empujador de rodillos/роликовый толкатель					
	(5) Mit 2 Ölbohrungen/with 2 oil holes/avec 2 trous d'huile/con 2 agujeros de aceite/c 2-мя смазочными отверстиями					
Fortsetzung nächste Seite / continued on next page / suite page suivante / continuación página próxima / Продолжение на следующей странице						

					Reference	Item No.
	I [1]				A 541 050 04 33 A 541 050 06 33 A 541 050 07 33 A 541 050 08 33 A 541 050 09 33 A 541 055 07 50	20 1003 50010 (6)
	[1]				A 541 050 05 34 A 541 050 06 34 A 541 050 07 34 A 541 050 08 34	20 1003 50011
	(6) IN					

**447**

**128**
**OM 457 Euro 2**
**945 - 946, 949**

01.1998 →

 D (LA) 6 11967 cm<sup>3</sup> 4V 220-260 kW (299-354 PS) 17,25:1 155,00 mm

97 411 7..

	IN [2]	45,5 x 9 x 144,9	RA/S- Cr -	- 30° - -	5 - III	A 457 053 00 01 A 541 050 02 26	<b>160054</b>
	IN [2]	45,5 x 9 x 145,0 M + 1	S - Cr -	- 30° - -	5 - III	A 460 053 00 01 A 541 053 01 01	<b>16204</b>
	EX [2]	17,0 x 8 x 87,0	A - -	- 45° - -	9 -	A 541 016 05 91 A 541 016 06 91 A 541 016 07 91	<b>261101</b> (1)
	EX [2]	41,0 x 9 x 145,0	RA/S- Cr -	- 45° - -	5 - III	A 541 050 01 27 A 541 050 02 27	<b>160055</b>
	EX [2]	42,1 x 9 x 145,0	RA/S- Cr -	- 36° - -	5 - III	A 457 050 03 27 A 457 050 05 27	<b>16205</b>
	(1)	Konstantdrosselventil - flach Exhaust brake valve - flat Soupape de réduction permanente - plate Válvula de reducción permanente - plana Постоянный дроссельный клапан					
	[50]	Ø 9 mm				A 541 053 00 26 A 541 053 01 26 A 541 053 02 26	<b>LK-2615</b>
	IN/EX [4]	15,03 x 9 x 61,0	G2			A 457 053 12 30 A 541 053 12 30 A 541 053 27 30	<b>81-16103</b> (2)
	IN/EX [4]	15,24 x 9 x 61,0	G2			A 457 053 13 30 A 541 053 13 30 A 541 053 28 30	<b>81-16104</b> (2)
	(2)	abweichend zu OE Bohrung fertigbearbeitet finish-machined with other than original bore usiné à un alésage différent de l'origine orificio mecanizado de manera diferente al original в отличие от OE отверстие расточено					
	IN [2]	47,38 x 40 x 7,7	G1 30°			A 541 053 17 31 A 541 053 21 31 A 541 053 26 31	<b>92-16157</b>
	IN [2]	47,39 x 36.6 x 7,8	G1 30°			A 457 053 16 31	<b>92-16156</b>
	EX [2]	43,10 x 34 x 8,0	G1 45°			A 541 053 05 32	<b>92-16158</b>
	[12]	M 30 x 75				A 541 050 03 22 A 541 050 05 22 A 541 050 07 22 A 541 050 13 22	<b>20 1003 50060</b> (3)
	[12]	M 30 x 75				A 541 050 17 22 A 541 050 20 22	<b>20 1003 50062</b> <b>NEW</b> (4)
	(3)	Rollenstößel/roller tappet/poussoir à galet/empujador de rodillos/роликовый толкатель					
	(4)	Mit 2 Ölbohrungen/with 2 oil holes/avec 2 trous d'huile/con 2 agujeros de aceite/c 2-мя смазочными отверстиями					

Fortsetzung nächste Seite / continued on next page / suite page suivante / continuación página próxima / Продолжение на следующей странице

					Reference	Item No.
I [1]					A 541 050 04 33 A 541 050 06 33 A 541 050 07 33 A 541 050 08 33 A 541 050 09 33 A 541 055 07 50	<b>20 1003 50010</b> (5)
[1]					A 541 050 05 34 A 541 050 06 34 A 541 050 07 34 A 541 050 08 34	<b>20 1003 50011</b>
(5) IN						

**448**
**128**
**OM 457 Euro 3**
**948, 957**

D (LA) 6 11967 cm<sup>3</sup> 4V 260-315 kW (354-428 PS) 17,25:1 155,00 mm

40 666 6..

IN [2]	45,5 x 9 x 144,9	RA/S- Cr -	- 30° - -	5 - III	A 457 053 00 01 A 541 050 02 26	<b>160054</b>
IN [2]	45,5 x 9 x 145,0 M + 1	S - Cr -	- 30° - -	5 - III	A 460 053 00 01 A 541 053 01 01	<b>16204</b>
EX [2]	17,0 x 8 x 87,0	A - -	- 45° - -	9 -	A 541 016 05 91 A 541 016 06 91 A 541 016 07 91	<b>261101</b> (1)
EX [2]	41,0 x 9 x 145,0	RA/S- Cr -	- 45° - -	5 - III	A 541 050 01 27 A 541 050 02 27	<b>160055</b>
EX [2]	42,1 x 9 x 145,0	RA/S- Cr -	- 36° - -	5 - III	A 457 050 03 27 A 457 050 05 27	<b>16205</b>
(1)	Konstantdrosselventil - flach Exhaust brake valve - flat Soupape de réduction permanente - plate Válvula de reducción permanente - plana Постоянный дроссельный клапан					
[50]	Ø 9 mm				A 541 053 00 26 A 541 053 01 26 A 541 053 02 26	<b>LK-2615</b>
IN/EX [4]	15,03 x 9 x 61,0	G2			A 457 053 12 30 A 541 053 12 30 A 541 053 27 30	<b>81-16103</b> (2)
IN/EX [4]	15,24 x 9 x 61,0	G2			A 457 053 13 30 A 541 053 13 30 A 541 053 28 30	<b>81-16104</b> (2)
(2)	abweichend zu OE Bohrung fertigbearbeitet finish-machined with other than original bore usiné à un alésage différent de l'origine orificio mecanizado de manera diferente al original в отличие от OE отверстие расточено					
IN [2]	47,38 x 40 x 7,7	G1 30°			A 541 053 17 31 A 541 053 21 31 A 541 053 26 31	<b>92-16157</b>
IN [2]	47,39 x 36.6 x 7,8	G1 30°			A 457 053 16 31	<b>92-16156</b>
EX [2]	43,10 x 34 x 8,0	G1 45°			A 541 053 05 32	<b>92-16158</b>
EX [1]	43,10 x 34.4 x 7,8	G1 36°			A 457 053 13 32	<b>92-16170</b> <small>NEW</small>
					A 460 050 06 01	<b>20 1003 46005</b>
[12]	M 30 x 75				A 541 050 03 22 A 541 050 05 22 A 541 050 07 22 A 541 050 13 22	<b>20 1003 50060</b> (3)
[12]	M 30 x 75				A 541 050 17 22 A 541 050 20 22	<b>20 1003 50062</b> <small>NEW</small> (4)

Fortsetzung nächste Seite / continued on next page / suite page suivante / continuación página próxima / Продолжение на следующей странице



					Reference	Item No.
(3)	Rollenstößel/roller tappet/poussoir à galet/empujador de rodillos/роликовый толкатель					
(4)	Mit 2 Ölbohrungen/with 2 oil holes/avec 2 trous d'huile/con 2 agujeros de aceite/c 2-мя смазочными отверстиями					
	I [1]				A 541 050 04 33 A 541 050 06 33 A 541 050 07 33 A 541 050 08 33 A 541 050 09 33 A 541 055 07 50	<b>20 1003 50010</b> (5)
	[1]				A 541 050 05 34 A 541 050 06 34 A 541 050 07 34 A 541 050 08 34	<b>20 1003 50011</b>
	(5) IN					

## 449 128

**OM 457 Euro 4 950 - 954, 959, 964 - 967, 969**

01.1998 → D (LA) 6 11967 cm<sup>3</sup> 4V 220-315 kW (299-428 PS) 17,25:1 155,00 mm

**OM 457 Euro 3 961**

08.1998 → D (LA) 6 11967 cm<sup>3</sup> 4V 260-355 kW (354-483 PS) 17,25:1 155,00 mm

40 666 6..

	IN [2]	45,5 x 9 x 144,9	RA/S- Cr -	- 30° - -	5 - III	A 457 053 00 01 A 541 050 02 26	<b>160054</b>	
	IN [2]	45,5 x 9 x 145,0	S - Cr -	- 30° - -	5 - III	A 460 053 00 01 A 541 053 01 01	<b>16204</b>	
	EX [2]	17,0 x 8 x 87,0	A - -	- 45° - -	9 -	A 541 016 05 91 A 541 016 06 91 A 541 016 07 91	<b>261101</b> (1)	
	EX [2]	41,0 x 9 x 145,0	RA/S- Cr -	- 45° - -	5 - III	A 541 050 01 27 A 541 050 02 27	<b>160055</b>	
	EX [2]	42,1 x 9 x 145,0	RA/S- Cr -	- 36° - -	5 - III	A 457 050 03 27 A 457 050 05 27	<b>16205</b>	
	(1)	Konstantdrosselventil - flach Exhaust brake valve - flat Soupape de réduction permanente - plate Válvula de reducción permanente - plana Постоянный дроссельный клапан						
	[50]	Ø 9 mm				A 541 053 00 26 A 541 053 01 26 A 541 053 02 26	<b>LK-2615</b>	
	IN/EX [4]	15,03 x 9 x 61,0	G2			A 457 053 12 30 A 541 053 12 30 A 541 053 27 30	<b>81-16103</b> (2)	
	IN/EX [4]	15,24 x 9 x 61,0	G2			A 457 053 13 30 A 541 053 13 30 A 541 053 28 30	<b>81-16104</b> (2)	
	(2)	abweichend zu OE Bohrung fertigbearbeitet finish-machined with other than original bore usiné à un alésage différent de l'origine orificio mecanizado de manera diferente al original в отличие от OE отверстие расточено						
	IN [2]	47,38 x 40 x 7,7	G1 30°			A 541 053 17 31 A 541 053 21 31 A 541 053 26 31	<b>92-16157</b>	
	IN [2]	47,39 x 36.6 x 7,8	G1 30°			A 457 053 16 31	<b>92-16156</b>	
	EX [2]	43,10 x 34 x 8,0	G1 45°			A 541 053 05 32	<b>92-16158</b>	
	EX [1]	43,10 x 34.4 x 7,8	G1 36°			A 457 053 13 32	<b>92-16170</b> <small>NEW</small>	
						A 460 050 06 01	<b>20 1003 46005</b>	

Fortsetzung nächste Seite / continued on next page / suite page suivante / continuación página próxima / Продолжение на следующей странице

					Reference	Item No.
[12]	M 30 x 75				A 541 050 17 22 A 541 050 20 22	<b>20 1003 50062</b> <small>NEW</small> (3)
(3)	Mit 2 Ölbohrungen/with 2 oil holes/avec 2 trous d'huile/con 2 agujeros de aceite/c 2-мя смазочными отверстиями					
I [1]					A 541 050 04 33 A 541 050 06 33 A 541 050 07 33 A 541 050 08 33 A 541 050 09 33 A 541 055 07 50	<b>20 1003 50010</b> (4)
[1]					A 541 050 05 34 A 541 050 06 34 A 541 050 07 34 A 541 050 08 34	<b>20 1003 50011</b>
(4)	IN					

## 450 128

**OM 457 Euro 3**
**981**

10.2005 →

D (LA)

6

 11967 cm<sup>3</sup> 4V

260-315 kW

(354-428 PS)

17,25:1

155,00 mm

**OM 457 Euro 4**
**973**

01.1998 →

D (LA)

6

 11967 cm<sup>3</sup> 4V

220-260 kW

(299-354 PS)

17,25:1

155,00 mm

40 666 6..

**M**

IN [2]	45,5 x 9 x 145,0 M + 1	S - Cr -	- 30° - -	5 - III	A 460 053 00 01 A 541 053 01 01	<b>16204</b>
EX [2]	42,1 x 9 x 145,0	RA/S- Cr -	- 36° - -	5 - III	A 457 050 03 27 A 457 050 05 27	<b>16205</b>
[50]	∅ 9 mm				A 541 053 00 26 A 541 053 01 26 A 541 053 02 26	<b>LK-2615</b>
IN/EX [4]	15,03 x 9 x 61,0	G2			A 457 053 12 30 A 541 053 12 30 A 541 053 27 30	<b>81-16103</b> (1)
IN/EX [4]	15,24 x 9 x 61,0	G2			A 457 053 13 30 A 541 053 13 30 A 541 053 28 30	<b>81-16104</b> (1)
(1)	abweichend zu OE Bohrung fertiggearbeitet finish-machined with other than original bore usiné à un alésage différent de l'origine orificio mecanizado de manera diferente al original в отличие от OE отверстие расточено					
IN [2]	47,38 x 40 x 7,7	G1 30°			A 541 053 17 31 A 541 053 21 31 A 541 053 26 31	<b>92-16157</b>
IN [2]	47,39 x 36.6 x 7,8	G1 30°			A 457 053 16 31	<b>92-16156</b>
EX [2]	43,10 x 34 x 8,0	G1 45°			A 541 053 05 32	<b>92-16158</b>
EX [1]	43,10 x 34.4 x 7,8	G1 36°			A 457 053 13 32	<b>92-16170</b> <small>NEW</small>
					A 460 050 06 01	<b>20 1003 46005</b>
[12]	M 30 x 75				A 541 050 17 22 A 541 050 20 22	<b>20 1003 50062</b> <small>NEW</small> (2)
(2)	Mit 2 Ölbohrungen/with 2 oil holes/avec 2 trous d'huile/con 2 agujeros de aceite/c 2-мя смазочными отверстиями					

Fortsetzung nächste Seite / continued on next page / suite page suivante / continuación página próxima / Продолжение на следующей странице

					Reference	Item No.
	I [1]				A 541 050 04 33 A 541 050 06 33 A 541 050 07 33 A 541 050 08 33 A 541 050 09 33 A 541 055 07 50	20 1003 50010 (3)
	[1]				A 541 050 05 34 A 541 050 06 34 A 541 050 07 34 A 541 050 08 34	20 1003 50011
	(3) IN					

**451**
**128**
**OM 458 Euro 3**
**960**

03.1998 →

 D (LA) 6 11967 cm<sup>3</sup> 4V

260 kW

(354 PS) 17,25:1 155,00 mm

40 742 6..., 99 948 6..

	IN [2]	45,5 x 9 x 144,9	RA/S- Cr -	- 30° - -	5 - III	A 457 053 00 01 A 541 050 02 26	<b>160054</b>
	IN [2]	45,5 x 9 x 145,0 M + 1	S - Cr -	- 30° - -	5 - III	A 460 053 00 01 A 541 053 01 01	<b>16204</b>
	EX [2]	17,0 x 8 x 87,0	A - -	- 45° - -	9 -	A 541 016 05 91 A 541 016 06 91 A 541 016 07 91	<b>261101</b> (1)
	EX [2]	41,0 x 9 x 145,0	RA/S- Cr -	- 45° - -	5 - III	A 541 050 01 27 A 541 050 02 27	<b>160055</b>
	EX [2]	42,1 x 9 x 145,0	RA/S- Cr -	- 36° - -	5 - III	A 457 050 03 27 A 457 050 05 27	<b>16205</b>
	(1)	Konstantdrosselventil - flach Exhaust brake valve - flat Soupape de réduction permanente - plate Válvula de reducción permanente - plana Постоянный дроссельный клапан					
	[50]	Ø 9 mm				A 541 053 00 26 A 541 053 01 26 A 541 053 02 26	<b>LK-2615</b>
	IN/EX [4]	15,03 x 9 x 61,0	G2			A 457 053 12 30 A 541 053 12 30 A 541 053 27 30	<b>81-16103</b> (2)
	IN/EX [4]	15,24 x 9 x 61,0	G2			A 457 053 13 30 A 541 053 13 30 A 541 053 28 30	<b>81-16104</b> (2)
	(2)	abweichend zu OE Bohrung fertigbearbeitet finish-machined with other than original bore usiné à un alésage différent de l'origine orificio mecanizado de manera diferente al original в отличие от OE отверстие расточено					
	IN [2]	47,38 x 40 x 7,7	G1 30°			A 541 053 17 31 A 541 053 21 31 A 541 053 26 31	<b>92-16157</b>
	IN [2]	47,39 x 36.6 x 7,8	G1 30°			A 457 053 16 31	<b>92-16156</b>
	EX [2]	43,10 x 34 x 8,0	G1 45°			A 541 053 05 32	<b>92-16158</b>
		1053 mm				A 457 050 13 01 A 457 050 23 01 A 457 050 30 01 A 460 050 01 01 A 460 050 04 01	<b>20 1003 45700</b> <b>20 1003 46000</b> (3)
	(3)	Flanschseite 6 x M10 Gewinde Flange 6x M10 thread La bride - le filet 6x M10 La brida - la rosca 6x M10 Фланцевая страница 6 x M10 резьба					

Fortsetzung nächste Seite / continued on next page / suite page suivante / continuación página próxima / Продолжение на следующей странице

					Reference	Item No.
[12]	M 30 x 75				A 541 050 03 22 A 541 050 05 22 A 541 050 07 22 A 541 050 13 22	<b>20 1003 50060</b> (4)
[12]	M 30 x 75				A 541 050 17 22 A 541 050 20 22	<b>20 1003 50062</b> <b>NEW</b> (5)
(4)	Rollenstößel/roller tappet/poussoir à galet/empujador de rodillos/роликовый толкатель					
(5)	Mit 2 Ölbohrungen/with 2 oil holes/avec 2 trous d'huile/con 2 agujeros de aceite/c 2-мя смазочными отверстиями					
I [1]					A 541 050 04 33 A 541 050 06 33 A 541 050 07 33 A 541 050 08 33 A 541 050 09 33 A 541 055 07 50	<b>20 1003 50010</b> (6)
[1]					A 541 050 05 34 A 541 050 06 34 A 541 050 07 34 A 541 050 08 34	<b>20 1003 50011</b>
(6)	IN					

**452** **128**
**OM 458 Euro 3**
**970, 980**

03.1998 →

 D (LA) 6 11967 cm<sup>3</sup> 4V 295-335 kW (401-456 PS) 17,25:1 155,00 mm

40 742 6..., 99 948 6..

IN [2]	45,5 x 9 x 144,9	RA/S- Cr -	- 30° - -	5 - III	A 457 053 00 01 A 541 050 02 26	<b>160054</b>
IN [2]	45,5 x 9 x 145,0 M + 1	S - Cr -	- 30° - -	5 - III	A 460 053 00 01 A 541 053 01 01	<b>16204</b>
EX [2]	17,0 x 8 x 87,0	A - -	- 45° - -	9 -	A 541 016 05 91 A 541 016 06 91 A 541 016 07 91	<b>261101</b> (1)
EX [2]	41,0 x 9 x 145,0	RA/S- Cr -	- 45° - -	5 - III	A 541 050 01 27 A 541 050 02 27	<b>160055</b>
EX [2]	42,1 x 9 x 145,0	RA/S- Cr -	- 36° - -	5 - III	A 457 050 03 27 A 457 050 05 27	<b>16205</b>
(1)	Konstantdrosselventil - flach Exhaust brake valve - flat Soupape de réduction permanente - plate Válvula de reducción permanente - plana Постоянный дроссельный клапан					
[50]	Ø 9 mm				A 541 053 00 26 A 541 053 01 26 A 541 053 02 26	<b>LK-2615</b>
IN/EX [4]	15,03 x 9 x 61,0	G2			A 457 053 12 30 A 541 053 12 30 A 541 053 27 30	<b>81-16103</b> (2)
IN/EX [4]	15,24 x 9 x 61,0	G2			A 457 053 13 30 A 541 053 13 30 A 541 053 28 30	<b>81-16104</b> (2)
(2)	abweichend zu OE Bohrung fertigbearbeitet finish-machined with other than original bore usiné à un alésage différent de l'origine orificio mecanizado de manera diferente al original в отличие от OE отверстие расточено					
IN [2]	47,38 x 40 x 7,7	G1 30°			A 541 053 17 31 A 541 053 21 31 A 541 053 26 31	<b>92-16157</b>
IN [2]	47,39 x 36.6 x 7,8	G1 30°			A 457 053 16 31	<b>92-16156</b>
EX [2]	43,10 x 34 x 8,0	G1 45°			A 541 053 05 32	<b>92-16158</b>
EX [1]	43,10 x 34.4 x 7,8	G1 36°			A 457 053 13 32	<b>92-16170</b> <b>NEW</b>

Fortsetzung nächste Seite / continued on next page / suite page suivante / continuación página próxima / Продолжение на следующей странице

					Reference	Item No.
	1053 mm				A 457 050 13 01 A 457 050 23 01 A 457 050 30 01 A 460 050 01 01 A 460 050 04 01	<b>20 1003 45700</b> <b>20 1003 46000</b> (3)
	(3) Flanschseite 6 x M10 Gewinde Flange 6x M10 thread La bride - le filet 6x M10 La brida - la rosca 6x M10 Фланцевая страница 6 x M10 резьба					
	[12] M 30 x 75				A 541 050 03 22 A 541 050 05 22 A 541 050 07 22 A 541 050 13 22	<b>20 1003 50060</b> (4)
	[12] M 30 x 75				A 541 050 17 22 A 541 050 20 22	<b>20 1003 50062</b> <small>NEW</small> (5)
	(4) Rollenstößel/roller tappet/poussoir à galet/empujador de rodillos/роликовый толкатель					
	(5) Mit 2 Ölbohrungen/with 2 oil holes/avec 2 trous d'huile/con 2 agujeros de aceite/c 2-мя смазочными отверстиями					
	I [1]				A 541 050 04 33 A 541 050 06 33 A 541 050 07 33 A 541 050 08 33 A 541 050 09 33 A 541 055 07 50	<b>20 1003 50010</b> (6)
	[1]				A 541 050 05 34 A 541 050 06 34 A 541 050 07 34 A 541 050 08 34	<b>20 1003 50011</b>
	(6) IN					

## 453 128

**OM 457 Euro 3**    **919 - 920, 923**  
08.1998 →    D (LA) 6 11967 cm<sup>3</sup> 4V 280-315 kW (381-428 PS) 17,25:1 155,00 mm  
40 742 6..., 99 948 6..

	IN [2]	45,5 x 9 x 144,9	RA/S- Cr -	- 30° - -	5 - III	A 457 053 00 01 A 541 050 02 26	<b>160054</b>
	IN [2]	45,5 x 9 x 145,0 M + 1	S - Cr -	- 30° - -	5 - III	A 460 053 00 01 A 541 053 01 01	<b>16204</b>
	EX [2]	17,0 x 8 x 87,0	A - -	- 45° - -	9 -	A 541 016 05 91 A 541 016 06 91 A 541 016 07 91	<b>261101</b> (1)
	EX [2]	41,0 x 9 x 145,0	RA/S- Cr -	- 45° - -	5 - III	A 541 050 01 27 A 541 050 02 27	<b>160055</b>
	EX [2]	42,1 x 9 x 145,0	RA/S- Cr -	- 36° - -	5 - III	A 457 050 03 27 A 457 050 05 27	<b>16205</b>
	(1) Konstantdrosselventil - flach Exhaust brake valve - flat Soupape de réduction permanente - plate Válvula de reducción permanente - plana Постоянный дроссельный клапан						
	[50]	Ø 9 mm				A 541 053 00 26 A 541 053 01 26 A 541 053 02 26	<b>LK-2615</b>
	IN/EX [4]	15,03 x 9 x 61,0	G2			A 457 053 12 30 A 541 053 12 30 A 541 053 27 30	<b>81-16103</b> (2)
	IN/EX [4]	15,24 x 9 x 61,0	G2			A 457 053 13 30 A 541 053 13 30 A 541 053 28 30	<b>81-16104</b> (2)

Fortsetzung nächste Seite / continued on next page / suite page suivante / continuación página próxima / Продолжение на следующей странице



					Reference	Item No.	
	(2)	abweichend zu OE Bohrung fertigbearbeitet finish-machined with other than original bore usiné à un alésage différent de l'origine orificio mecanizado de manera diferente al original в отличие от OE отверстие расточено					
	IN [2]	47,38 x 40 x 7,7	G1 30°		A 541 053 17 31 A 541 053 21 31 A 541 053 26 31	<b>92-16157</b>	
	IN [2]	47,39 x 36.6 x 7,8	G1 30°		A 457 053 16 31	<b>92-16156</b>	
	EX [2]	43,10 x 34 x 8,0	G1 45°		A 541 053 05 32	<b>92-16158</b>	
		1053 mm			A 457 050 31 01	<b>20 1003 45704</b>	
	[12]	M 30 x 75			A 541 050 03 22 A 541 050 05 22 A 541 050 07 22 A 541 050 13 22	<b>20 1003 50060</b> (3)	
	(3)	Rollenstößel/roller tappet/poussoir à galet/empujador de rodillos/роликовый толкатель					
	I [1]				A 541 050 04 33 A 541 050 06 33 A 541 050 07 33 A 541 050 08 33 A 541 050 09 33 A 541 055 07 50	<b>20 1003 50010</b> (4)	
	[1]				A 541 050 05 34 A 541 050 06 34 A 541 050 07 34 A 541 050 08 34	<b>20 1003 50011</b>	
	(4)	IN					

## 454 128

OM 457 Euro 2/3 **937, 941, 944**

D (LA) 6 11967 cm<sup>3</sup> 4V 185-315 kW (252-428 PS) 17,25:1 155,00 mm

OM 457 Euro 3 **956**

D (LA) 6 11967 cm<sup>3</sup> 4V 260-315 kW (354-428 PS) 17,25:1 155,00 mm

97 411 7..

	IN [2]	45,5 x 9 x 144,9	RA/S- Cr -	- 30° - -	5 - III	A 457 053 00 01 A 541 050 02 26	<b>160054</b>
	IN [2]	45,5 x 9 x 145,0	S - Cr -	- 30° - -	5 - III	A 460 053 00 01 A 541 053 01 01	<b>16204</b>
	EX [2]	17,0 x 8 x 87,0	A - -	- 45° - -	9 -	A 541 016 05 91 A 541 016 06 91 A 541 016 07 91	<b>261101</b> (1)
	EX [2]	41,0 x 9 x 145,0	RA/S- Cr -	- 45° - -	5 - III	A 541 050 01 27 A 541 050 02 27	<b>160055</b>
	EX [2]	42,1 x 9 x 145,0	RA/S- Cr -	- 36° - -	5 - III	A 457 050 03 27 A 457 050 05 27	<b>16205</b>
	(1)	Konstantdrosselventil - flach Exhaust brake valve - flat Soupape de réduction permanente - plate Válvula de reducción permanente - plana Постоянный дроссельный клапан					
	[50]	Ø 9 mm				A 541 053 00 26 A 541 053 01 26 A 541 053 02 26	<b>LK-2615</b>
	IN/EX [4]	15,03 x 9 x 61,0	G2			A 457 053 12 30 A 541 053 12 30 A 541 053 27 30	<b>81-16103</b> (2)
	IN/EX [4]	15,24 x 9 x 61,0	G2			A 457 053 13 30 A 541 053 13 30 A 541 053 28 30	<b>81-16104</b> (2)

Fortsetzung nächste Seite / continued on next page / suite page suivante / continuación página próxima / Продолжение на следующей странице

					Reference	Item No.	
	(2)	abweichend zu OE Bohrung fertigbearbeitet finish-machined with other than original bore usiné à un alésage différent de l'origine orificio mecanizado de manera diferente al original в отличие от OE отверстия расточено					
	IN [2]	47,38 x 40 x 7,7	G1 30°		A 541 053 17 31 A 541 053 21 31 A 541 053 26 31	<b>92-16157</b>	
	IN [2]	47,39 x 36.6 x 7,8	G1 30°		A 457 053 16 31	<b>92-16156</b>	
	EX [2]	43,10 x 34 x 8,0	G1 45°		A 541 053 05 32	<b>92-16158</b>	
	EX [1]	43,10 x 34.4 x 7,8	G1 36°		A 457 053 13 32	<b>92-16170</b> <small>NEW</small>	
					A 457 050 23 01 A 457 050 30 01 A 460 050 01 01 A 460 050 04 01 A 460 050 06 01	<b>20 1003 46000</b> (3)  <b>20 1003 46005</b>	
	(3)	Flanschseite 6 x M10 Gewinde Flange 6x M10 thread La bride - le filet 6x M10 La brida - la rosca 6x M10 Фланцевая страница 6 x M10 резьба					
	[12]	M 30 x 75			A 541 050 03 22 A 541 050 05 22 A 541 050 07 22 A 541 050 13 22	<b>20 1003 50060</b> (4)	
	[12]	M 30 x 75			A 541 050 17 22 A 541 050 20 22	<b>20 1003 50062</b> <small>NEW</small> (5)	
	(4)	Rollenstößel/roller tappet/poussoir à galet/empujador de rodillos/роликовый толкатель					
	(5)	Mit 2 Ölbohrungen/with 2 oil holes/avec 2 trous d'huile/con 2 agujeros de aceite/c 2-мя смазочными отверстиями					
	I [1]				A 541 050 04 33 A 541 050 06 33 A 541 050 07 33 A 541 050 08 33 A 541 050 09 33 A 541 055 07 50	<b>20 1003 50010</b> (6)	
	[1]				A 541 050 05 34 A 541 050 06 34 A 541 050 07 34 A 541 050 08 34	<b>20 1003 50011</b>	
	(6)	IN					
<b>455</b>		<b>128</b>					
<b>OM 457 Euro 3</b>	<b>962</b>						
	09.2008 →	D (LA)	6	11967 cm <sup>3</sup>	4V	260-315 kW (354-428 PS) 17,25:1 155,00 mm	
<b>OM 457 Euro 2</b>	<b>947, 960</b>						
	08.1998 →	D (LA)	6	11967 cm <sup>3</sup>	4V	260-315 kW (354-428 PS) 17,25:1 155,00 mm	
40 666 6..							
	IN [2]	45,5 x 9 x 144,9	RA/S- Cr -	- 30° - -	5 - III	A 457 053 00 01 A 541 050 02 26	<b>160054</b>
	IN [2]	45,5 x 9 x 145,0	S - Cr -	- 30° - -	5 - III	A 460 053 00 01 A 541 053 01 01	<b>16204</b>
	EX [2]	17,0 x 8 x 87,0	A - -	- 45° - -	9 -	A 541 016 05 91 A 541 016 06 91 A 541 016 07 91	<b>261101</b> (1)
	EX [2]	41,0 x 9 x 145,0	RA/S- Cr -	- 45° - -	5 - III	A 541 050 01 27 A 541 050 02 27	<b>160055</b>
	EX [2]	42,1 x 9 x 145,0	RA/S- Cr -	- 36° - -	5 - III	A 457 050 03 27 A 457 050 05 27	<b>16205</b>
Fortsetzung nächste Seite / continued on next page / suite page suivante / continuación página próxima / Продолжение на следующей странице							

M

					Reference	Item No.
(1)	Konstantdrosselventil - flach Exhaust brake valve - flat Soupape de réduction permanente - plate Válvula de reducción permanente - plana Постоянный дроссельный клапан					
[50]	Ø 9 mm				A 541 053 00 26 A 541 053 01 26 A 541 053 02 26	<b>LK-2615</b>
IN/EX [4]	15,03 x 9 x 61,0	G2			A 457 053 12 30 A 541 053 12 30 A 541 053 27 30	<b>81-16103</b> (2)
IN/EX [4]	15,24 x 9 x 61,0	G2			A 457 053 13 30 A 541 053 13 30 A 541 053 28 30	<b>81-16104</b> (2)
(2)	abweichend zu OE Bohrung fertigbearbeitet finish-machined with other than original bore usiné à un alésage différent de l'origine orificio mecanizado de manera diferente al original в отличие от OE отверстие расточено					
IN [2]	47,38 x 40 x 7,7	G1 30°			A 541 053 17 31 A 541 053 21 31 A 541 053 26 31	<b>92-16157</b>
IN [2]	47,39 x 36.6 x 7,8	G1 30°			A 457 053 16 31	<b>92-16156</b>
EX [2]	43,10 x 34 x 8,0	G1 45°			A 541 053 05 32	<b>92-16158</b>
EX [1]	43,10 x 34.4 x 7,8	G1 36°			A 457 053 13 32	<b>92-16170</b> <small>NEW</small>
					A 457 050 23 01 A 457 050 30 01 A 460 050 01 01 A 460 050 04 01 A 460 050 06 01	<b>20 1003 46000</b> (3)  <b>20 1003 46005</b>
(3)	Flanschseite 6 x M10 Gewinde Flange 6x M10 thread La bride - le filet 6x M10 La brida - la rosca 6x M10 Фланцевая страница 6 x M10 резьба					
[12]	M 30 x 75				A 541 050 17 22 A 541 050 20 22	<b>20 1003 50062</b> <small>NEW</small> (4)
(4)	Mit 2 Ölbohrungen/with 2 oil holes/avec 2 trous d'huile/con 2 agujeros de aceite/c 2-мя смазочными отверстиями					
I [1]					A 541 050 04 33 A 541 050 06 33 A 541 050 07 33 A 541 050 08 33 A 541 050 09 33 A 541 055 07 50	<b>20 1003 50010</b> (5)
[1]					A 541 050 05 34 A 541 050 06 34 A 541 050 07 34 A 541 050 08 34	<b>20 1003 50011</b>
(5)	IN					

**456** **128**
**OM 457 Euro 4**
**968**

08.1998 →

D

(LA)

6

 11967 cm<sup>3</sup> 4V

265-315 kW

(360-428 PS)

17,25:1 155,00 mm

40 666 6..

Fortsetzung nächste Seite / continued on next page / suite page suivante / continuación página próxima / Продолжение на следующей странице

					Reference	Item No.
	IN [2] 45,5 x 9 x 144,9	RA/S- Cr -	- 30° - -	5 - III	A 457 053 00 01 A 541 050 02 26	<b>160054</b>
	IN [2] 45,5 x 9 x 145,0 M + 1	S - Cr -	- 30° - -	5 - III	A 460 053 00 01 A 541 053 01 01	<b>16204</b>
	EX [2] 17,0 x 8 x 87,0	A - -	- 45° - -	9 -	A 541 016 05 91 A 541 016 06 91 A 541 016 07 91	<b>261101</b> (1)
	EX [2] 41,0 x 9 x 145,0	RA/S- Cr -	- 45° - -	5 - III	A 541 050 01 27 A 541 050 02 27	<b>160055</b>
	EX [2] 42,1 x 9 x 145,0	RA/S- Cr -	- 36° - -	5 - III	A 457 050 03 27 A 457 050 05 27	<b>16205</b>
	(1) Konstantdrosselventil - flach Exhaust brake valve - flat Soupape de réduction permanente - plate Válvula de reducción permanente - plana Постоянный дроссельный клапан					
	[50] Ø 9 mm				A 541 053 00 26 A 541 053 01 26 A 541 053 02 26	<b>LK-2615</b>
	IN/EX [4] 15,03 x 9 x 61,0	G2			A 457 053 12 30 A 541 053 12 30 A 541 053 27 30	<b>81-16103</b> (2)
	IN/EX [4] 15,24 x 9 x 61,0	G2			A 457 053 13 30 A 541 053 13 30 A 541 053 28 30	<b>81-16104</b> (2)
	(2) abweichend zu OE Bohrung fertigbearbeitet finish-machined with other than original bore usiné à un alésage différent de l'origine orificio mecanizado de manera diferente al original в отличие от OE отверстие расточено					
	IN [2] 47,38 x 40 x 7,7	G1 30°			A 541 053 17 31 A 541 053 21 31 A 541 053 26 31	<b>92-16157</b>
	IN [2] 47,39 x 36.6 x 7,8	G1 30°			A 457 053 16 31	<b>92-16156</b>
	EX [2] 43,10 x 34 x 8,0	G1 45°			A 541 053 05 32	<b>92-16158</b>
	EX [1] 43,10 x 34.4 x 7,8	G1 36°			A 457 053 13 32	<b>92-16170</b> <small>NEW</small>
					A 460 050 06 01	<b>20 1003 46005</b>
	[12] M 30 x 75				A 541 050 17 22 A 541 050 20 22	<b>20 1003 50062</b> <small>NEW</small> (3)
	(3) Mit 2 Ölbohrungen/with 2 oil holes/avec 2 trous d'huile/con 2 agujeros de aceite/c 2-мя смазочными отверстиями					
<b>457</b>		<b>128</b>				
<b>OM 457 Euro 3</b>	<b>976</b>					
	08.1998 →	D (LA)	6	11967 cm <sup>3</sup>	4V	260-335 kW (354-456 PS) 17,25:1 155,00 mm
<b>OM 457 Euro 4</b>	<b>974, 977</b>					
	08.1998 →	D (LA)	6	11967 cm <sup>3</sup>	4V	220-300 kW (299-408 PS) 17,25:1 155,00 mm
<b>OM 458</b>	<b>990 - 991</b>					
		D (LA)	6	11967 cm <sup>3</sup>	4V	220-375 kW (299-510 PS) 18:1 155,00 mm
40 666 6.., 40 726 6..						
	IN [2] 45,5 x 9 x 145,0 M + 1	S - Cr -	- 30° - -	5 - III	A 460 053 00 01 A 541 053 01 01	<b>16204</b>
	EX [2] 42,1 x 9 x 145,0	RA/S- Cr -	- 36° - -	5 - III	A 457 050 03 27 A 457 050 05 27	<b>16205</b>
	[50] Ø 9 mm				A 541 053 00 26 A 541 053 01 26 A 541 053 02 26	<b>LK-2615</b>
Fortsetzung nächste Seite / continued on next page / suite page suivante / continuación página próxima / Продолжение на следующей странице						

					Reference	Item No.
	IN/EX [4] 15,03 x 9 x 61,0	G2			A 457 053 12 30 A 541 053 12 30 A 541 053 27 30	<b>81-16103</b> (1)
	IN/EX [4] 15,24 x 9 x 61,0	G2			A 457 053 13 30 A 541 053 13 30 A 541 053 28 30	<b>81-16104</b> (1)
	(1) abweichend zu OE Bohrung fertigbearbeitet finish-machined with other than original bore usiné à un alésage différent de l'origine orificio mecanizado de manera diferente al original в отличие от OE отверстие расточено					
	EX [1] 43,10 x 34.4 x 7,8	G1 36°			A 457 053 13 32	<b>92-16170</b> <small>NEW</small>
					A 460 050 06 01	<b>20 1003 46005</b>
	[12] M 30 x 75				A 541 050 17 22 A 541 050 20 22	<b>20 1003 50062</b> <small>NEW</small> (2)
	(2) Mit 2 Ölbohrungen/with 2 oil holes/avec 2 trous d'huile/con 2 agujeros de aceite/c 2-мя смазочными отверстиями					
	I [1]				A 541 050 04 33 A 541 050 06 33 A 541 050 07 33 A 541 050 08 33 A 541 050 09 33 A 541 055 07 50	<b>20 1003 50010</b> (3)
	[1]				A 541 050 05 34 A 541 050 06 34 A 541 050 07 34 A 541 050 08 34	<b>20 1003 50011</b>
	(3) IN					

## 458 128

OM 475

979

01.1999 → 12.2002 D (LA) 5 9973 cm<sup>3</sup> 2V 235 kW (320 PS) 16,25:1 155,00 mm

	IN [1] 59,0 x 12 x 142,5	A/S - Cr -	- 30° - -	5 - III	A 403 053 09 01 A 422 050 00 26 A 422 050 02 26 A 422 050 05 26 A 422 053 01 01 A 423 050 00 26 A 442 050 02 26 A 442 050 03 26	<b>16117</b>
	EX [1] 51,0 x 12 x 142,5	RA/S- Cr -	- 45° - -	5 - III	A 422 050 01 27 A 422 050 02 27 A 442 050 01 27 A 442 050 02 27 A 442 050 03 27 A 442 050 04 27	<b>16150</b>
	IN/EX [6] 18,03 x 12 x 67,0	G2			A 422 053 04 30	<b>81-16100</b>
	IN [1] 60,11 x 49.3 x 8,4	G1 30°			A 422 053 01 31 A 447 053 00 31	<b>92-16150</b>
	EX [2] 53,11 x 43 x 9,2	G1 45°			A 442 053 00 32	<b>92-16127</b>
	EX [1] 53,11 x 43 x 9,2	G1 45°			A 422 053 01 32	<b>92-16126</b>
	EX [1] 53,31 x 43 x 9,4	G1 45°			A 442 053 01 32	<b>92-16149</b>
	EX [1] 53,51 x 43.2 x 9,6	G1 45°			A 442 053 02 32	<b>92-16128</b>
	[12] M 32 x 76 x 20				A 422 050 03 25 A 476 050 00 25	<b>20 1003 44000</b> (1)

Fortsetzung nächste Seite / continued on next page / suite page suivante / continuación página próxima / Продолжение на следующей странице



					Reference	Item No.
(1)	OES specification					
	[4]				A 403 050 07 33 A 442 050 03 33	20 1002 25010 (2)
	[1]				A 403 050 03 33 A 403 050 07 33 A 442 050 03 33	20 1003 40010
	[1]				A 403 050 03 33 A 403 050 07 33 A 442 050 03 33 A 442 055 00 20	20 1003 40012 (3)
(2)	nur 2-Ventiler/only 2 valves version/seulement 2 soupapes/sólo sistemas de 2 válvulas/заменяемо Клапаны					
(3)	mit Einstellschraube/with adjusting screw/avec vis de réglage/con tornillo de ajuste/c установочным винтом					

**459** **128**
**OM 447 Euro 2**
**903**

 09.1999 → 09.2006 D (LA) 6 11970 cm<sup>3</sup> 2V 184 kW (250 PS) 155,00 mm

40 176 6..., 93 171 6..

	IN [1]	59,0 x 12 x 142,5	A/S - Cr -	- 30° -	-	5 - III	A 403 053 09 01 A 422 050 00 26 A 422 050 02 26 A 422 050 05 26 A 422 053 01 01 A 423 050 00 26 A 442 050 02 26 A 442 050 03 26	16117
	IN [1]	59,0 x 12 x 142,5	A/S - Cr -	- 30° -	-	5 - III	A 442 050 05 26	16146
	EX [1]	51,0 x 12 x 142,5	RA/S- Cr -	- 45° -	-	5 - III	A 422 050 01 27 A 422 050 02 27 A 442 050 01 27 A 442 050 02 27 A 442 050 03 27 A 442 050 04 27	16150
	[50]	Ø 12 mm					A 422 053 00 26	LK-1610
	IN/EX [6]	18,03 x 12 x 67,0	G2				A 422 053 04 30	81-16100
	IN [2]	60,11 x 51.2 x 8,4	G1 30°				A 422 053 05 31	92-16151
	IN [1]	60,11 x 49.3 x 8,4	G1 30°				A 422 053 01 31 A 447 053 00 31	92-16150
	IN [1]	60,31 x 51.2 x 8,6	G1 30°				A 422 053 06 31	92-16152
	EX [2]	53,11 x 43 x 9,2	G1 45°				A 442 053 00 32	92-16127
	EX [1]	53,11 x 43 x 9,2	G1 45°				A 422 053 01 32	92-16126
	EX [1]	53,31 x 43 x 9,4	G1 45°				A 442 053 01 32	92-16149
	EX [1]	53,51 x 43.2 x 9,6	G1 45°				A 442 053 02 32	92-16128
		1047 mm					A 447 050 19 01	20 1003 44701
	[12]	M 31,5 x 76,5 x 20					A 403 054 09 01 A 403 054 18 01	20 1003 40060
	[12]	M 32 x 76 x 20					A 422 050 03 25 A 476 050 00 25	20 1003 44000 (1)
	[12]	M 32 x 76 x 20					A 422 050 03 25 A 476 050 00 25	20 1003 44001 <sup>NEW</sup> (2)
	(1)	OES specification						
	(2)	IAM specification						

Fortsetzung nächste Seite / continued on next page / suite page suivante / continuación página próxima / Продолжение на следующей странице

					Reference	Item No.
[4] [1] [1]					A 403 050 07 33 A 442 050 03 33 A 403 050 03 33 A 403 050 07 33 A 442 050 03 33 A 403 050 03 33 A 403 050 07 33 A 442 050 03 33 A 442 055 00 20	<b>20 1002 25010</b> (3) <b>20 1003 40010</b> <b>20 1003 40012</b> (4)
(3) nur 2-Ventiler/only 2 valves version/seulement 2 soupapes/sólo sistemas de 2 válvulas/заменяемо 2 Клапаны (4) mit Einstellschraube/with adjusting screw/avec vis de réglage/con tornillo de ajuste/c установочным ВИНТОМ						
	- - G - S -	- - - -			A 402 010 03 20 A 403 010 40 20 A 403 010 89 20 A 427 010 00 20 A 427 010 10 20 A 429 010 02 20 A 442 010 07 20	<b>20 0803 40300</b>
	- V - G - S -	- - - -	ready-to-install		A 427 010 10 20	<b>20 0803 40301</b>

M

## 460 128

OM 457 Euro 3

922

10.1999 →

D (LA) 6 11967 cm<sup>3</sup> 4V 320-325 kW (435-442 PS) 17,25:1 155,00 mm

40 742 6..., 99 948 6..

	IN [2]	45,5 x 9 x 144,9	RA/S- Cr -	- 30° - -	5 - III	A 457 053 00 01 A 541 050 02 26	<b>160054</b>
	IN [2]	45,5 x 9 x 145,0 M + 1	S - Cr -	- 30° - -	5 - III	A 460 053 00 01 A 541 053 01 01	<b>16204</b>
	EX [2]	17,0 x 8 x 87,0	A - -	- 45° - -	9 -	A 541 016 05 91 A 541 016 06 91 A 541 016 07 91	<b>261101</b> (1)
	EX [2]	41,0 x 9 x 145,0	RA/S- Cr -	- 45° - -	5 - III	A 541 050 01 27 A 541 050 02 27	<b>160055</b>
	EX [2]	42,1 x 9 x 145,0	RA/S- Cr -	- 36° - -	5 - III	A 457 050 03 27 A 457 050 05 27	<b>16205</b>
	(1) Konstantdrosselventil - flach Exhaust brake valve - flat Soupape de réduction permanente - plate Válvula de reducción permanente - plana Постоянный дроссельный клапан						
	[50]	Ø 9 mm				A 541 053 00 26 A 541 053 01 26 A 541 053 02 26	<b>LK-2615</b>

Fortsetzung nächste Seite / continued on next page / suite page suivante / continuación página próxima / Продолжение на следующей странице

					Reference	Item No.
	IN/EX [4] 15,03 x 9 x 61,0	G2			A 457 053 12 30 A 541 053 12 30 A 541 053 27 30	<b>81-16103</b> (2)
	IN/EX [4] 15,24 x 9 x 61,0	G2			A 457 053 13 30 A 541 053 13 30 A 541 053 28 30	<b>81-16104</b> (2)
	(2) abweichend zu OE Bohrung fertigbearbeitet finish-machined with other than original bore usiné à un alésage différent de l'origine orificio mecanizado de manera diferente al original в отличие от OE отверстия расточено					
	IN [2] 47,38 x 40 x 7,7	G1 30°			A 541 053 17 31 A 541 053 21 31 A 541 053 26 31	<b>92-16157</b>
	IN [2] 47,39 x 36.6 x 7,8	G1 30°			A 457 053 16 31	<b>92-16156</b>
	EX [2] 43,10 x 34 x 8,0	G1 45°			A 541 053 05 32	<b>92-16158</b>
					A 457 050 25 01	<b>20 1003 45701</b> (3)
	(3) Zähnezahl 73 gear z=73 Nombre de dents 73 Número des dientes 73 число зубьев 73					
	[12] M 30 x 75				A 541 050 03 22 A 541 050 05 22 A 541 050 07 22 A 541 050 13 22	<b>20 1003 50060</b> (4)
	(4) Rollenstößel/roller tappet/poussoir à galet/empujador de rodillos/роликовый толкатель					
	I [1]				A 541 050 04 33 A 541 050 06 33 A 541 050 07 33 A 541 050 08 33 A 541 050 09 33 A 541 055 07 50	<b>20 1003 50010</b> (5)
	[1]				A 541 050 05 34 A 541 050 06 34 A 541 050 07 34 A 541 050 08 34	<b>20 1003 50011</b>
	(5) IN					

**461**

**128**
**OM 457 Euro 3**
**915 - 916, 927**

01.2001 →

 D (LA) 6 11967 cm<sup>3</sup> 4V 265-295 kW (360-401 PS) 17,25:1 155,00 mm

40 742 6.., 99 948 6..

	IN [2] 45,5 x 9 x 144,9	RA/S- Cr -	- 30° - -	5 - III	A 457 053 00 01 A 541 050 02 26	<b>160054</b>
	IN [2] 45,5 x 9 x 145,0	S - Cr -	- 30° - -	5 - III	A 460 053 00 01 A 541 053 01 01	<b>16204</b>
	EX [2] 17,0 x 8 x 87,0	A - -	- 45° - -	9 -	A 541 016 05 91 A 541 016 06 91 A 541 016 07 91	<b>261101</b> (1)
	EX [2] 41,0 x 9 x 145,0	RA/S- Cr -	- 45° - -	5 - III	A 541 050 01 27 A 541 050 02 27	<b>160055</b>
	EX [2] 42,1 x 9 x 145,0	RA/S- Cr -	- 36° - -	5 - III	A 457 050 03 27 A 457 050 05 27	<b>16205</b>
	(1) Konstantdrosselventil - flach Exhaust brake valve - flat Soupape de réduction permanente - plate Válvula de reducción permanente - plana Постоянный дроссельный клапан					

Fortsetzung nächste Seite / continued on next page / suite page suivante / continuación página próxima / Продолжение на следующей странице

					Reference	Item No.
[50]	Ø 9 mm				A 541 053 00 26 A 541 053 01 26 A 541 053 02 26	<b>LK-2615</b>
IN/EX [4]	15,03 x 9 x 61,0	G2			A 457 053 12 30 A 541 053 12 30 A 541 053 27 30	<b>81-16103</b> (2)
IN/EX [4]	15,24 x 9 x 61,0	G2			A 457 053 13 30 A 541 053 13 30 A 541 053 28 30	<b>81-16104</b> (2)
	(2) abweichend zu OE Bohrung fertigmachbearbeitet finish-machined with other than original bore usiné à un alésage différent de l'origine orificio mecanizado de manera diferente al original в отличие от OE отверстие расточено					
IN [2]	47,38 x 40 x 7,7	G1 30°			A 541 053 17 31 A 541 053 21 31 A 541 053 26 31	<b>92-16157</b>
IN [2]	47,39 x 36.6 x 7,8	G1 30°			A 457 053 16 31	<b>92-16156</b>
EX [2]	43,10 x 34 x 8,0	G1 45°			A 541 053 05 32	<b>92-16158</b>
EX [1]	43,10 x 34.4 x 7,8	G1 36°			A 457 053 13 32	<b>92-16170</b> <small>NEW</small>
	1053 mm				A 457 050 31 01	<b>20 1003 45704</b>
[12]	M 30 x 75				A 541 050 03 22 A 541 050 05 22 A 541 050 07 22 A 541 050 13 22	<b>20 1003 50060</b> (3)
	(3) Rollenstößel/roller tappet/poussoir à galet/empujador de rodillos/роликовый толкатель					
I [1]					A 541 050 04 33 A 541 050 06 33 A 541 050 07 33 A 541 050 08 33 A 541 050 09 33 A 541 055 07 50	<b>20 1003 50010</b> (4)
[1]					A 541 050 05 34 A 541 050 06 34 A 541 050 07 34 A 541 050 08 34	<b>20 1003 50011</b>
	(4) IN					

## 462 128

OM 457 Euro 3

932

01.2001 →

D (LA) 6 11967 cm<sup>3</sup> 4V

265 kW

(360 PS) 17,25:1 155,00 mm

40 742 6..., 99 948 6..

IN [2]	45,5 x 9 x 144,9	RA/S- Cr -	- 30° - -	5 - III	A 457 053 00 01 A 541 050 02 26	<b>160054</b>
IN [2]	45,5 x 9 x 145,0 M + 1	S - Cr -	- 30° - -	5 - III	A 460 053 00 01 A 541 053 01 01	<b>16204</b>
EX [2]	17,0 x 8 x 87,0	A - -	- 45° - -	9 -	A 541 016 05 91 A 541 016 06 91 A 541 016 07 91	<b>261101</b> (1)
EX [2]	41,0 x 9 x 145,0	RA/S- Cr -	- 45° - -	5 - III	A 541 050 01 27 A 541 050 02 27	<b>160055</b>
EX [2]	42,1 x 9 x 145,0	RA/S- Cr -	- 36° - -	5 - III	A 457 050 03 27 A 457 050 05 27	<b>16205</b>
	(1) Konstantdrosselventil - flach Exhaust brake valve - flat Soupape de réduction permanente - plate Válvula de reducción permanente - plana Постоянный дроссельный клапан					

Fortsetzung nächste Seite / continued on next page / suite page suivante / continuación página próxima / Продолжение на следующей странице

					Reference	Item No.
[50]	Ø 9 mm				A 541 053 00 26 A 541 053 01 26 A 541 053 02 26	<b>LK-2615</b>
IN/EX [4]	15,03 x 9 x 61,0	G2			A 457 053 12 30 A 541 053 12 30 A 541 053 27 30	<b>81-16103</b> (2)
IN/EX [4]	15,24 x 9 x 61,0	G2			A 457 053 13 30 A 541 053 13 30 A 541 053 28 30	<b>81-16104</b> (2)
	(2) abweichend zu OE Bohrung fertiggearbeitet finish-machined with other than original bore usiné à un alésage différent de l'origine orificio mecanizado de manera diferente al original в отличие от OE отверстие расточено					
IN [2]	47,38 x 40 x 7,7	G1 30°			A 541 053 17 31 A 541 053 21 31 A 541 053 26 31	<b>92-16157</b>
IN [2]	47,39 x 36.6 x 7,8	G1 30°			A 457 053 16 31	<b>92-16156</b>
EX [2]	43,10 x 34 x 8,0	G1 45°			A 541 053 05 32	<b>92-16158</b>
	1053 mm 1053 mm				A 457 050 13 01 A 457 050 31 01	<b>20 1003 45700</b> <b>20 1003 45704</b>
[12]	M 30 x 75				A 541 050 03 22 A 541 050 05 22 A 541 050 07 22 A 541 050 13 22	<b>20 1003 50060</b> (3)
	(3) Rollenstößel/roller tappet/poussoir à galet/empujador de rodillos/роликовый толкатель					
I [1]					A 541 050 04 33 A 541 050 06 33 A 541 050 07 33 A 541 050 08 33 A 541 050 09 33 A 541 055 07 50	<b>20 1003 50010</b> (4)
[1]					A 541 050 05 34 A 541 050 06 34 A 541 050 07 34 A 541 050 08 34	<b>20 1003 50011</b>
	(4) IN					

## 463 128

OM 447 Euro 1

947, 960

11.2001 →

D (LA) 6

11967 cm<sup>3</sup> 2V

184-220 kW

(250-299 PS)

155,00 mm

40 111 6..., 91 237 6..., 91 467 6..

IN [1]	59,0 x 12 x 142,5	A/S - Cr -	- 30° -	-	5 - III	A 403 053 09 01 A 422 050 00 26 A 422 050 02 26 A 422 050 05 26 A 422 053 01 01 A 423 050 00 26 A 442 050 02 26 A 442 050 03 26	<b>16117</b>
IN [1]	59,0 x 12 x 142,5	A/S - Cr -	- 30° -	-	5 - III	A 442 050 05 26	<b>16146</b>
EX [1]	51,0 x 12 x 142,5	RA/S- Cr -	- 45° -	-	5 - III	A 422 050 01 27 A 422 050 02 27 A 442 050 01 27 A 442 050 02 27 A 442 050 03 27 A 442 050 04 27	<b>16150</b>
[50]	Ø 12 mm					A 422 053 00 26	<b>LK-1610</b>
Fortsetzung nächste Seite / continued on next page / suite page suivante / continuación página próxima / Продолжение на следующей странице							



					Reference	Item No.
IN/EX [6]	18,03 x 12 x 67,0	G2			A 422 053 04 30	<b>81-16100</b>
IN [2]	60,11 x 51.2 x 8,4	G1 30°			A 422 053 05 31	<b>92-16151</b>
IN [1]	60,31 x 51.2 x 8,6	G1 30°			A 422 053 06 31	<b>92-16152</b>
EX [2]	53,11 x 43 x 9,2	G1 45°			A 442 053 00 32	<b>92-16127</b>
EX [1]	53,11 x 43 x 9,2	G1 45°			A 422 053 01 32	<b>92-16126</b>
EX [1]	53,31 x 43 x 9,4	G1 45°			A 442 053 01 32	<b>92-16149</b>
EX [1]	53,51 x 43.2 x 9,6	G1 45°			A 442 053 02 32	<b>92-16128</b>
[12]	M 32 x 76 x 20				A 422 050 03 25 A 476 050 00 25	<b>20 1003 44000</b> (1)
	(1) OES specification					
[4]					A 403 050 07 33 A 442 050 03 33	<b>20 1002 25010</b> (2)
[1]					A 403 050 03 33	<b>20 1003 40010</b>
[1]					A 403 050 07 33 A 442 050 03 33 A 403 050 03 33 A 403 050 07 33 A 442 050 03 33 A 442 055 00 20	<b>20 1003 40012</b> (3)
	(2) nur 2-Ventiler/only 2 valves version/seulement 2 soupapes/sólo sistemas de 2 válvulas/заменяемо 2 Клапаны					
	(3) mit Einstellschraube/with adjusting screw/avec vis de réglage/con tornillo de ajuste/c установочным ВИНТОМ					

## 464 128

OM 447 Euro 2

948 - 949

11.2001 →

D (LA) 6 11967 cm<sup>3</sup> 2V 157-220 kW (214-299 PS) 16,25:1 155,00 mm

40 111 6.., 91 467 6..

IN [1]	59,0 x 12 x 142,5	A/S - Cr -	- 30° - -	5 - III	A 403 053 09 01 A 422 050 00 26 A 422 050 02 26 A 422 050 05 26 A 422 053 01 01 A 423 050 00 26 A 442 050 02 26 A 442 050 03 26	<b>16117</b>
IN [1]	59,0 x 12 x 142,5	A/S - Cr -	- 30° - -	5 - III	A 442 050 05 26	<b>16146</b>
EX [1]	51,0 x 12 x 142,5	RA/S- Cr -	- 45° - -	5 - III	A 422 050 01 27 A 422 050 02 27 A 442 050 01 27 A 442 050 02 27 A 442 050 03 27 A 442 050 04 27	<b>16150</b>
[50]	Ø 12 mm				A 422 053 00 26	<b>LK-1610</b>
IN/EX [6]	18,03 x 12 x 67,0	G2			A 422 053 04 30	<b>81-16100</b>
EX [2]	53,11 x 43 x 9,2	G1 45°			A 442 053 00 32	<b>92-16127</b>
EX [1]	53,11 x 43 x 9,2	G1 45°			A 422 053 01 32	<b>92-16126</b>
EX [1]	53,31 x 43 x 9,4	G1 45°			A 442 053 01 32	<b>92-16149</b>
EX [1]	53,51 x 43.2 x 9,6	G1 45°			A 442 053 02 32	<b>92-16128</b>
	1047 mm				A 447 050 19 01	<b>20 1003 44701</b>
[12]	M 32 x 76 x 20				A 422 050 03 25 A 476 050 00 25	<b>20 1003 44000</b> (1)

Fortsetzung nächste Seite / continued on next page / suite page suivante / continuación página próxima / Продолжение на следующей странице

					Reference	Item No.
(1)	OES specification					
[4]					A 403 050 07 33 A 442 050 03 33	<b>20 1002 25010</b> (2)
[1]					A 403 050 03 33 A 403 050 07 33 A 442 050 03 33	<b>20 1003 40010</b>
[1]					A 403 050 03 33 A 403 050 07 33 A 442 050 03 33 A 442 055 00 20	<b>20 1003 40012</b> (3)
(2)	nur 2-Ventiler/only 2 valves version/seulement 2 soupapes/sólo sistemas de 2 válvulas/заменяемо 2 Клапаны					
(3)	mit Einstellschraube/with adjusting screw/avec vis de réglage/con tornillo de ajuste/c установочным ВИНТОМ					

## 465 128

<b>OM 457 Euro 5</b>	<b>983, 985</b>	D (LA)	6	11967 cm <sup>3</sup>	4V	260-335 kW	(354-455 PS)	155,00 mm
<b>OM 457 Euro 3</b>	<b>975</b>	D (LA)	6	11967 cm <sup>3</sup>	4V	260 kW	(354 PS)	17,2 155,00 mm
<b>OM 460 Euro 3</b>	<b>953, 972, 988</b>	D (LA)	6	12816 cm <sup>3</sup>	4V	265-390 kW	(360-530 PS)	18:1 166,00 mm
<b>OM 460</b>	<b>984</b>	D (A)	6	12816 cm <sup>3</sup>	4V	335-375 kW	(455-510 PS)	166,00 mm

41 943 6..

	IN [2]	45,5 x 9 x 145,0 M + 1	S - Cr -	- 30° - -	5 - III	A 460 053 00 01 A 541 053 01 01	<b>16204</b>
	EX [2]	42,1 x 9 x 145,0	RA/S- Cr -	- 36° - -	5 - III	A 457 050 03 27 A 457 050 05 27	<b>16205</b>
	[50]	Ø 9 mm				A 541 053 00 26 A 541 053 01 26 A 541 053 02 26	<b>LK-2615</b>
	IN/EX [4]	15,03 x 9 x 61,0	G2			A 457 053 12 30 A 541 053 12 30 A 541 053 27 30	<b>81-16103</b> (1)
	IN/EX [4]	15,24 x 9 x 61,0	G2			A 457 053 13 30 A 541 053 13 30 A 541 053 28 30	<b>81-16104</b> (1)
	(1)	abweichend zu OE Bohrung fertigbearbeitet finish-machined with other than original bore usiné à un alésage différent de l'origine orificio mecanizado de manera diferente al original в отличие от OE отверстие расточено					
	IN [2]	47,38 x 40 x 7,7	G1 30°			A 541 053 17 31 A 541 053 21 31 A 541 053 26 31	<b>92-16157</b>
	IN [2]	47,39 x 36.6 x 7,8	G1 30°			A 457 053 16 31	<b>92-16156</b>
	EX [2]	43,10 x 34 x 8,0	G1 45°			A 541 053 05 32	<b>92-16158</b>
	EX [1]	43,10 x 34.4 x 7,8	G1 36°			A 457 053 13 32	<b>92-16170</b> <small>NEW</small>

## 466 128

<b>OM 457 Euro 5</b>	<b>908 - 909</b>	D (LA)	6	11970 cm <sup>3</sup>	4V	260 kW	(354 PS)	17,25:1 155,00 mm
<b>OM 460 Euro 3</b>	<b>952</b>	D (LA)	6	12816 cm <sup>3</sup>	4V	261 kW	(350 PS)	18:1 166,00 mm

41 857 6..

Fortsetzung nächste Seite / continued on next page / suite page suivante / continuación página próxima / Продолжение на следующей странице

					Reference	Item No.
I [1]					A 541 050 04 33 A 541 050 06 33 A 541 050 07 33 A 541 050 08 33 A 541 050 09 33 A 541 055 07 50	<b>20 1003 50010</b> (1)
[1]					A 541 050 05 34 A 541 050 06 34 A 541 050 07 34 A 541 050 08 34	<b>20 1003 50011</b>
(1) IN						

## 467 128

OM 460 Euro 3

982 - 983

2004 →

D (LA) 6 12816 cm<sup>3</sup> 4V 324-336 kW (441-457 PS) 18:1 166,00 mm

41 857 6..

EX [1]	43,10 x 34.4 x 7,8	G1 36°			A 457 053 13 32	<b>92-16170</b> <small>NEW</small>
					A 460 050 06 01	<b>20 1003 46005</b>
I [1]					A 541 050 04 33 A 541 050 06 33 A 541 050 07 33 A 541 050 08 33 A 541 050 09 33 A 541 055 07 50	<b>20 1003 50010</b> (1)
[1]					A 541 050 05 34 A 541 050 06 34 A 541 050 07 34 A 541 050 08 34	<b>20 1003 50011</b>
(1) IN						

## 468 128

OM 457 Euro 2/3

917

10.2004 →

D (LA) 6 11967 cm<sup>3</sup> 4V 260-315 kW (354-428 PS) 17,25:1 155,00 mm

99 948 6..

IN [2]	45,5 x 9 x 144,9	RA/S- Cr -	- 30° -	- 5 - III	A 457 053 00 01 A 541 050 02 26	<b>160054</b>
IN [2]	45,5 x 9 x 145,0 M + 1	S - Cr -	- 30° -	- 5 - III	A 460 053 00 01 A 541 053 01 01	<b>16204</b>
EX [2]	17,0 x 8 x 87,0	A - -	- 45° -	- 9 -	A 541 016 05 91 A 541 016 06 91 A 541 016 07 91	<b>261101</b> (1)
EX [2]	41,0 x 9 x 145,0	RA/S- Cr -	- 45° -	- 5 - III	A 541 050 01 27 A 541 050 02 27	<b>160055</b>
EX [2]	42,1 x 9 x 145,0	RA/S- Cr -	- 36° -	- 5 - III	A 457 050 03 27 A 457 050 05 27	<b>16205</b>
(1)	Konstantdrosselventil - flach Exhaust brake valve - flat Soupape de réduction permanente - plate Válvula de reducción permanente - plana Постоянный дроссельный клапан					
[50]	Ø 9 mm				A 541 053 00 26 A 541 053 01 26 A 541 053 02 26	<b>LK-2615</b>

Fortsetzung nächste Seite / continued on next page / suite page suivante / continuación página próxima / Продолжение на следующей странице

					Reference	Item No.
	IN/EX [4] 15,03 x 9 x 61,0	G2			A 457 053 12 30 A 541 053 12 30 A 541 053 27 30	<b>81-16103</b> (2)
	IN/EX [4] 15,24 x 9 x 61,0	G2			A 457 053 13 30 A 541 053 13 30 A 541 053 28 30	<b>81-16104</b> (2)
	(2) abweichend zu OE Bohrung fertiggearbeitet finish-machined with other than original bore usiné à un alésage différent de l'origine orificio mecanizado de manera diferente al original в отличие от OE отверстия расточено					
	IN [2] 47,38 x 40 x 7,7	G1 30°			A 541 053 17 31 A 541 053 21 31 A 541 053 26 31	<b>92-16157</b>
	IN [2] 47,39 x 36.6 x 7,8	G1 30°			A 457 053 16 31	<b>92-16156</b>
	EX [2] 43,10 x 34 x 8,0	G1 45°			A 541 053 05 32	<b>92-16158</b>
	EX [1] 43,10 x 34.4 x 7,8	G1 36°			A 457 053 13 32	<b>92-16170</b>
	(3) Flanschseite 6 x M10 Gewinde Flange 6x M10 thread La bride - le filet 6x M10 La brida - la rosca 6x M10 Фланцевая страница 6 x M10 резьба				A 457 050 23 01 A 457 050 30 01 A 460 050 01 01 A 460 050 04 01	<b>20 1003 46000</b> (3)
	I [1]				A 541 050 04 33 A 541 050 06 33 A 541 050 07 33 A 541 050 08 33 A 541 050 09 33 A 541 055 07 50	<b>20 1003 50010</b> (4)
	[1]				A 541 050 05 34 A 541 050 06 34 A 541 050 07 34 A 541 050 08 34	<b>20 1003 50011</b>
	(4) IN					

## 469 128

OM 457 Euro 3

918

10.2004 →

D (LA) 6 11967 cm<sup>3</sup> 4V 260-315 kW (354-428 PS) 17,25:1 155,00 mm

40 742 6.., 99 948 6..

	IN [2] 45,5 x 9 x 144,9	RA/S- Cr -	- 30° - -	5 - III	A 457 053 00 01 A 541 050 02 26	<b>160054</b>
	IN [2] 45,5 x 9 x 145,0	S - Cr -	- 30° - -	5 - III	A 460 053 00 01 A 541 053 01 01	<b>16204</b>
	EX [2] 17,0 x 8 x 87,0	A - -	- 45° - -	9 -	A 541 016 05 91 A 541 016 06 91 A 541 016 07 91	<b>261101</b> (1)
	EX [2] 41,0 x 9 x 145,0	RA/S- Cr -	- 45° - -	5 - III	A 541 050 01 27 A 541 050 02 27	<b>160055</b>
	EX [2] 42,1 x 9 x 145,0	RA/S- Cr -	- 36° - -	5 - III	A 457 050 03 27 A 457 050 05 27	<b>16205</b>
	(1) Konstantdrosselventil - flach Exhaust brake valve - flat Soupape de réduction permanente - plate Válvula de reducción permanente - plana Постоянный дроссельный клапан					
	[50] Ø 9 mm				A 541 053 00 26 A 541 053 01 26 A 541 053 02 26	<b>LK-2615</b>

Fortsetzung nächste Seite / continued on next page / suite page suivante / continuación página próxima / Продолжение на следующей странице

					Reference	Item No.
	IN/EX [4] 15,03 x 9 x 61,0	G2			A 457 053 12 30 A 541 053 12 30 A 541 053 27 30	<b>81-16103</b> (2)
	IN/EX [4] 15,24 x 9 x 61,0	G2			A 457 053 13 30 A 541 053 13 30 A 541 053 28 30	<b>81-16104</b> (2)
	(2) abweichend zu OE Bohrung fertigbearbeitet finish-machined with other than original bore usiné à un alésage différent de l'origine orificio mecanizado de manera diferente al original в отличие от OE отверстие расточено					
	IN [2] 47,38 x 40 x 7,7	G1 30°			A 541 053 17 31 A 541 053 21 31 A 541 053 26 31	<b>92-16157</b>
	IN [2] 47,39 x 36.6 x 7,8	G1 30°			A 457 053 16 31	<b>92-16156</b>
	EX [2] 43,10 x 34 x 8,0	G1 45°			A 541 053 05 32	<b>92-16158</b>
	EX [1] 43,10 x 34.4 x 7,8	G1 36°			A 457 053 13 32	<b>92-16170</b>
	1053 mm				A 457 050 23 01 A 457 050 30 01 A 460 050 01 01 A 460 050 04 01 A 457 050 31 01	<b>20 1003 46000</b> (3)  <b>20 1003 45704</b>
	(3) Flanschseite 6 x M10 Gewinde Flange 6x M10 thread La bride - le filet 6x M10 La brida - la rosca 6x M10 Фланцевая страница 6 x M10 резьба					
	[12] M 30 x 75				A 541 050 03 22 A 541 050 05 22 A 541 050 07 22 A 541 050 13 22	<b>20 1003 50060</b> (4)
	[12] M 30 x 75				A 541 050 17 22 A 541 050 20 22	<b>20 1003 50062</b> (5)
	(4) Rollenstößel/roller tappet/poussoir à galet/empujador de rodillos/роликовый толкатель					
	(5) Mit 2 Ölbohrungen/with 2 oil holes/avec 2 trous d'huile/con 2 agujeros de aceite/c 2-мя смазочными отверстиями					
	I [1]				A 541 050 04 33 A 541 050 06 33 A 541 050 07 33 A 541 050 08 33 A 541 050 09 33 A 541 055 07 50	<b>20 1003 50010</b> (6)
	[1]				A 541 050 05 34 A 541 050 06 34 A 541 050 07 34 A 541 050 08 34	<b>20 1003 50011</b>
	(6) IN					

**470**
**128**
**OM 457 Euro 2**
**980**

10.2004 →

 D (LA) 6 11967 cm<sup>3</sup> 4V 260-315 kW (354-428 PS) 17,25:1 155,00 mm

40 666 6..

	IN [2] 45,5 x 9 x 145,0 M + 1	S - Cr -	- 30° - -	5 - III	A 460 053 00 01 A 541 053 01 01	<b>16204</b>
	EX [2] 42,1 x 9 x 145,0	RA/S- Cr -	- 36° - -	5 - III	A 457 050 03 27 A 457 050 05 27	<b>16205</b>
	[50] Ø 9 mm				A 541 053 00 26 A 541 053 01 26 A 541 053 02 26	<b>LK-2615</b>

Fortsetzung nächste Seite / continued on next page / suite page suivante / continuación página próxima / Продолжение на следующей странице



					Reference	Item No.
	IN/EX [4] 15,03 x 9 x 61,0	G2			A 457 053 12 30 A 541 053 12 30 A 541 053 27 30	<b>81-16103</b> (1)
	IN/EX [4] 15,24 x 9 x 61,0	G2			A 457 053 13 30 A 541 053 13 30 A 541 053 28 30	<b>81-16104</b> (1)
	(1) abweichend zu OE Bohrung fertiggearbeitet finish-machined with other than original bore usiné à un alésage différent de l'origine orificio mecanizado de manera diferente al original в отличие от OE отверстие расточено					
	EX [1] 43,10 x 34.4 x 7,8	G1 36°			A 457 053 13 32	<b>92-16170</b> <span style="border: 1px solid black; padding: 1px;">NEW</span>
					A 457 050 23 01 A 457 050 30 01 A 460 050 01 01 A 460 050 04 01 A 460 050 06 01	<b>20 1003 46000</b> (2)  <b>20 1003 46005</b>
	(2) Flanschseite 6 x M10 Gewinde Flange 6x M10 thread La bride - le filet 6x M10 La brida - la rosca 6x M10 Фланцевая страница 6 x M10 резьба					
	[12] M 30 x 75				A 541 050 17 22 A 541 050 20 22	<b>20 1003 50062</b> <span style="border: 1px solid black; padding: 1px;">NEW</span> (3)
	(3) Mit 2 Ölbohrungen/with 2 oil holes/avec 2 trous d'huile/con 2 agujeros de aceite/c 2-мя смазочными отверстиями					
	I [1]				A 541 050 04 33 A 541 050 06 33 A 541 050 07 33 A 541 050 08 33 A 541 050 09 33 A 541 055 07 50 A 541 050 05 34 A 541 050 06 34 A 541 050 07 34 A 541 050 08 34	<b>20 1003 50010</b> (4)  <b>20 1003 50011</b>
	[1]					
	(4) IN					

## 471 128

**OM 460 Euro 3** 900 - 905, 907 - 916, 918 - 919, 921 - 923, 925, 929, 931, 970 - 971  
01.2012 → D (LA) 6 12816 cm<sup>3</sup> 4V 261-338 kW (355-460 PS) 18:1 166,00 mm  
40 264 6..

	IN [2] 45,5 x 9 x 144,9	RA/S- Cr -	- 30° - -	5 - III	A 457 053 00 01 A 541 050 02 26	<b>160054</b>
	IN [2] 45,5 x 9 x 145,0	S - Cr -	- 30° - -	5 - III	A 460 053 00 01 A 541 053 01 01	<b>16204</b>
	EX [2] 17,0 x 8 x 87,0	A - -	- 45° - -	9 -	A 541 016 05 91 A 541 016 06 91 A 541 016 07 91	<b>261101</b> (1)
	EX [2] 41,0 x 9 x 145,0	RA/S- Cr -	- 45° - -	5 - III	A 541 050 01 27 A 541 050 02 27	<b>160055</b>
	EX [2] 42,1 x 9 x 145,0	RA/S- Cr -	- 36° - -	5 - III	A 457 050 03 27 A 457 050 05 27	<b>16205</b>
	(1) Konstantdrosselventil - flach Exhaust brake valve - flat Soupape de réduction permanente - plate Válvula de reducción permanente - plana Постоянный дроссельный клапан					

Fortsetzung nächste Seite / continued on next page / suite page suivante / continuación página próxima / Продолжение на следующей странице

					Reference	Item No.
[50]	Ø 9 mm				A 541 053 00 26 A 541 053 01 26 A 541 053 02 26	<b>LK-2615</b>
IN/EX [4]	15,03 x 9 x 61,0	G2			A 457 053 12 30 A 541 053 12 30 A 541 053 27 30	<b>81-16103</b> (2)
IN/EX [4]	15,24 x 9 x 61,0	G2			A 457 053 13 30 A 541 053 13 30 A 541 053 28 30	<b>81-16104</b> (2)
	(2) abweichend zu OE Bohrung fertigmachend finish-machined with other than original bore usiné à un alésage différent de l'origine orificio mecanizado de manera diferente al original в отличие от OE отверстие расточено					
IN [2]	47,38 x 40 x 7,7	G1 30°			A 541 053 17 31 A 541 053 21 31 A 541 053 26 31	<b>92-16157</b>
IN [2]	47,39 x 36.6 x 7,8	G1 30°			A 457 053 16 31	<b>92-16156</b>
EX [2]	43,10 x 34 x 8,0	G1 45°			A 541 053 05 32	<b>92-16158</b>
EX [1]	43,10 x 34.4 x 7,8	G1 36°			A 457 053 13 32	<b>92-16170</b> <small>NEW</small>
					A 457 050 23 01 A 457 050 30 01 A 460 050 01 01 A 460 050 04 01	<b>20 1003 46000</b> (3)
	(3) Flanschseite 6 x M10 Gewinde Flange 6x M10 thread La bride - le filet 6x M10 La brida - la rosca 6x M10 Фланцевая страница 6 x M10 резьба					
[12]	M 30 x 75				A 541 050 03 22 A 541 050 05 22 A 541 050 07 22 A 541 050 13 22	<b>20 1003 50060</b> (4)
	(4) Rollenstößel/roller tappet/poussoir à galet/empujador de rodillos/роликовый толкатель					
I [1]					A 541 050 04 33 A 541 050 06 33 A 541 050 07 33 A 541 050 08 33 A 541 050 09 33 A 541 055 07 50	<b>20 1003 50010</b> (5)
[1]					A 541 050 05 34 A 541 050 06 34 A 541 050 07 34 A 541 050 08 34	<b>20 1003 50011</b>
	(5) IN					

## 472 128

OM 457 Euro 4

970

05.2015→

D (LA)

6

11967 cm<sup>3</sup> 4V

315 kW

(428 PS) 17,25:1 155,00 mm

40 666 6..

IN [2]	45,5 x 9 x 145,0 M + 1	S - Cr -	- 30° - -	5 - III	A 460 053 00 01 A 541 053 01 01	<b>16204</b>
EX [2]	42,1 x 9 x 145,0	RA/S- Cr -	- 36° - -	5 - III	A 457 050 03 27 A 457 050 05 27	<b>16205</b>
[50]	Ø 9 mm				A 541 053 00 26 A 541 053 01 26 A 541 053 02 26	<b>LK-2615</b>

Fortsetzung nächste Seite / continued on next page / suite page suivante / continuación página próxima / Продолжение на следующей странице

					Reference	Item No.
	IN/EX [4] 15,03 x 9 x 61,0	G2			A 457 053 12 30 A 541 053 12 30 A 541 053 27 30	<b>81-16103</b> (1)
	IN/EX [4] 15,24 x 9 x 61,0	G2			A 457 053 13 30 A 541 053 13 30 A 541 053 28 30	<b>81-16104</b> (1)
	(1) abweichend zu OE Bohrung fertiggearbeitet finish-machined with other than original bore usiné à un alésage différent de l'origine orificio mecanizado de manera diferente al original в отличие от OE отверстия расточено					
	IN [2] 47,38 x 40 x 7,7	G1 30°			A 541 053 17 31 A 541 053 21 31 A 541 053 26 31	<b>92-16157</b>
	IN [2] 47,39 x 36.6 x 7,8	G1 30°			A 457 053 16 31	<b>92-16156</b>
	EX [2] 43,10 x 34 x 8,0	G1 45°			A 541 053 05 32	<b>92-16158</b>
	EX [1] 43,10 x 34.4 x 7,8	G1 36°			A 457 053 13 32	<b>92-16170</b>
					A 460 050 06 01	<b>20 1003 46005</b>
	[12] M 30 x 75				A 541 050 17 22 A 541 050 20 22	<b>20 1003 50062</b> (2)
	(2) Mit 2 Ölbohrungen/with 2 oil holes/avec 2 trous d'huile/con 2 agujeros de aceite/c 2-мя смазочными отверстиями					

## 473 128

OM 345

**914-001 (BRA), 914-002 (BRA), 914-003 (BRA), 914-004 (BRA), 914-005 (BRA)**

D 6 11581 cm<sup>3</sup> 2V 103-135 kW (140-185 PS) 17,2:1 150,00 mm

93 568 6..

	IN [2] 42,0 x 9 x 129,8	S - Cr -	- 45° - -	5 - III	A 345 053 71 01 A 346 053 00 01 A 346 053 01 01 A 346 053 03 01	<b>1657</b>
	EX [2] 37,0 x 9 x 165,3	A/S - Cr -	- 45° - -	5 - III	A 345 053 71 05 A 346 053 01 05 A 346 053 02 05 A 355 050 01 27	<b>1658</b>
	IN [6] 15,04 x 9 x 68,5	G1			A 346 053 09 29	<b>81-1640</b>
	IN [4] 15,20 x 9 x 67,5	G1			A 346 053 11 29	<b>81-1642</b>
	EX [6] 15,00 x 9 x 86,5	G1			A 355 053 03 30	<b>81-1641</b>
	IN [2] 51,06 x 37 x 7,5	G1 45°			A 346 053 07 31 A 355 053 11 31	<b>92-16106</b>
	IN [1] 51,26 x 37 x 7,5	G1 45°			A 346 053 08 31	<b>92-16140</b>
	IN [1] 51,46 x 37 x 7,5	G1 45°			A 355 053 09 31 A 355 053 13 31	<b>92-16142</b>
	EX [2] 40,10 x 31 x 7,5	G1 45°			A 345 053 01 32 A 346 053 05 32 A 355 053 06 32 A 355 053 10 32 A 355 053 18 32	<b>92-16110</b>
	EX [1] 40,46 x 31 x 7,5	G1 45°			A 355 053 12 32 A 355 053 20 32	<b>92-16143</b>
	1105 mm				A 355 051 04 01	<b>20 1003 35500</b>

## 474 128

OM 355

**978**

D (NA) 6 11581 cm<sup>3</sup> 4V 177 kW (240 PS) 17,2:1 150,00 mm

93 568 6..

Fortsetzung nächste Seite / continued on next page / suite page suivante / continuación página próxima / Продолжение на следующей странице

					Reference	Item No.
IN [2]	42,0 x 9 x 129,8	S - Cr -	- 45° - -	5 - III	A 345 053 71 01 A 346 053 00 01 A 346 053 01 01 A 346 053 03 01	<b>1657</b>
EX [2]	37,0 x 9 x 165,3	A/S - Cr -	- 45° - -	5 - III	A 345 053 71 05 A 346 053 01 05 A 346 053 02 05 A 355 050 01 27	<b>1658</b>
IN [6]	15,04 x 9 x 68,5	G1			A 346 053 09 29	<b>81-1640</b>
IN [4]	15,20 x 9 x 67,5	G1			A 346 053 11 29	<b>81-1642</b>
EX [6]	15,00 x 9 x 86,5	G1			A 355 053 03 30	<b>81-1641</b>
IN [2]	51,06 x 37 x 7,5	G1 45°			A 346 053 07 31 A 355 053 11 31	<b>92-16106</b>
IN [1]	51,46 x 37 x 7,5	G1 45°			A 355 053 09 31 A 355 053 13 31	<b>92-16142</b>
EX [2]	40,10 x 31 x 7,5	G1 45°			A 345 053 01 32 A 346 053 05 32 A 355 053 06 32 A 355 053 10 32 A 355 053 18 32	<b>92-16110</b>
EX [1]	40,26 x 31 x 7,5	G1 45°			A 346 053 06 32	<b>92-16141</b>
EX [1]	40,46 x 31 x 7,5	G1 45°			A 355 053 12 32 A 355 053 20 32	<b>92-16143</b>
	1105 mm				A 355 051 04 01	<b>20 1003 35500</b>
[12]	M 34 x 70				A 345 054 70 01 A 346 054 02 01 A 355 054 01 01	<b>20 1003 35560</b>

M

**475**

**128**

OM 422

900/-000

D

8 14618 cm<sup>3</sup> 2V

142,00 mm

93 484 6.., 93 484 7..

IN [1]	59,0 x 12 x 142,5	A/S - Cr -	- 30° - -	5 - III	A 403 053 09 01 A 422 050 00 26 A 422 050 02 26 A 422 050 05 26 A 422 053 01 01 A 423 050 00 26 A 442 050 02 26 A 442 050 03 26	<b>16117</b>
IN [1]	59,0 x 12 x 142,5	A/S - Cr -	- 30° - -	5 - III	A 442 050 05 26	<b>16146</b>
IN [1]	59,0 x 12 x 142,5	S - Cr -	- 30° - VS -	5 - III	A 423 050 00 26	<b>1606</b>
EX [1]	51,0 x 12 x 142,5	A/S - Cr -	- 45° - -	5 - III	A 422 050 00 27	<b>16116</b>
EX [1]	51,0 x 12 x 142,5	RA/S- Cr -	- 45° - -	5 - III	A 422 050 01 27 A 422 050 02 27 A 442 050 01 27 A 442 050 02 27 A 442 050 03 27 A 442 050 04 27	<b>16150</b>
EX [1]	51,1 x 12 x 142,5	A/S - Cr -	- 45° - -	5 - III	A 423 050 04 27	<b>1608</b>
[50]					A 000 053 04 26	<b>LK-1605</b>
[50]	Ø 12 mm				A 422 053 00 26	<b>LK-1610</b>
IN/EX [6]	18,03 x 12 x 67,0	G2			A 422 053 04 30	<b>81-16100</b>

Fortsetzung nächste Seite / continued on next page / suite page suivante / continuación página próxima / Продолжение на следующей странице

					Reference	Item No.	
	IN [2]	60,11 x 51 x 8,9	G1 30°		A 403 053 09 31 A 403 053 15 31	<b>92-16100</b>	
	IN [1]	60,31 x 51 x 9,1	G1 30°		A 403 053 10 31	<b>92-16147</b>	
	IN [1]	60,51 x 51 x 9,3	G1 30°		A 403 053 11 31	<b>92-16101</b>	
	EX [2]	53,11 x 43 x 9,7	G1 45°		A 403 053 00 32 A 403 053 03 32 A 403 053 21 32 A 403 053 25 32 A 403 053 28 32	<b>92-16104</b>	
	EX [1]	53,31 x 43 x 9,9	G1 45°		A 403 053 01 32 A 403 053 13 32 A 403 053 22 32 A 403 053 26 32 A 403 053 29 32	<b>92-16148</b>	
	EX [1]	53,51 x 43 x 10,2	G1 45°		A 403 053 02 32 A 403 053 23 32 A 403 053 27 32 A 403 053 30 32	<b>92-16105</b>	
		724 mm				A 422 050 01 01 A 422 050 03 01 A 422 050 05 01 A 422 050 21 01	<b>20 1003 42200</b>
		[12]	M 32 x 76 x 20			A 422 050 03 25 A 476 050 00 25	<b>20 1003 44000</b> (1)
		[12]	M 32 x 76 x 20			A 422 050 03 25 A 476 050 00 25	<b>20 1003 44001</b> <small>NEW</small> (2)
		(1)	OES specification				
(2)	IAM specification						
	[4]				A 403 050 07 33 A 442 050 03 33	<b>20 1002 25010</b> (3)	
	[1]				A 403 050 03 33	<b>20 1003 40010</b>	
	[1]				A 403 050 07 33 A 442 050 03 33 A 403 050 03 33 A 403 050 07 33 A 442 050 03 33 A 442 055 00 20	<b>20 1003 40012</b> (4)	
	(3)	nur 2-Ventiler/only 2 valves version/seulement 2 soupapes/sólo sistemas de 2 válvulas/заменяемо 2 Клапаны					
	(4)	mit Einstellschraube/with adjusting screw/avec vis de réglage/con tornillo de ajuste/c установочным винтом					
	Fortsetzung nächste Seite / continued on next page / suite page suivante / continuación página próxima / Продолжение на следующей странице						



					Reference	Item No.
	- - G - S -	- - -			A 402 010 03 20 A 403 010 40 20 A 403 010 89 20 A 427 010 00 20 A 427 010 10 20 A 429 010 02 20 A 442 010 07 20	<b>20 0803 40300</b>
	- V - G - S -	- - -	ready-to-install		A 427 010 10 20	<b>20 0803 40301</b>

**476**
**128**
**OM 422**
**901**

D (A) 8 14618 cm<sup>3</sup> 2V 243-276 kW (330-375 PS) 16,25:1 142,00 mm

93 484 6.., 93 484 7.., 93 485 6..

**M**

	IN [1]	59,0 x 12 x 142,5	A/S - Cr -	- 30° - -	5 - III	A 403 053 09 01 A 422 050 00 26 A 422 050 02 26 A 422 050 05 26 A 422 053 01 01 A 423 050 00 26 A 442 050 02 26 A 442 050 03 26	<b>16117</b>
	IN [1]	59,0 x 12 x 142,5	A/S - Cr -	- 30° - -	5 - III	A 442 050 05 26	<b>16146</b>
	IN [1]	59,0 x 12 x 142,5	S - Cr -	- 30° - VS -	5 - III	A 423 050 00 26	<b>1606</b>
	EX [1]	51,0 x 12 x 142,5	A/S - Cr -	- 45° - -	5 - III	A 422 050 00 27	<b>16116</b>
	EX [1]	51,0 x 12 x 142,5	RA/S- Cr -	- 45° - -	5 - III	A 422 050 01 27 A 422 050 02 27 A 442 050 02 27 A 442 050 03 27 A 442 050 04 27	<b>16150</b>
	EX [1]	51,1 x 12 x 142,5	A/S - Cr -	- 45° - -	5 - III	A 423 050 04 27	<b>1608</b>
	[50]	Ø 12 mm				A 422 053 00 26	<b>LK-1610</b>
	IN/EX [6]	18,03 x 12 x 67,0	G1			A 403 053 00 30	<b>81-1647</b>
	IN/EX [6]	18,03 x 12 x 67,0	G2			A 422 053 04 30	<b>81-16100</b>
	IN/EX [6]	18,23 x 12 x 67,0	G1			A 403 053 01 30	<b>81-1648</b>

Fortsetzung nächste Seite / continued on next page / suite page suivante / continuación página próxima / Продолжение на следующей странице

					Reference	Item No.
	IN [2] 60,11 x 51 x 8,9	G1 30°			A 403 053 09 31 A 403 053 15 31	<b>92-16100</b>
	IN [2] 60,11 x 51.2 x 8,4	G1 30°			A 422 053 05 31	<b>92-16151</b>
	IN [1] 60,31 x 51 x 9,1	G1 30°			A 403 053 10 31	<b>92-16147</b>
	IN [1] 60,31 x 51.2 x 8,6	G1 30°			A 422 053 06 31	<b>92-16152</b>
	IN [1] 60,51 x 51 x 9,3	G1 30°			A 403 053 11 31	<b>92-16101</b>
	EX [2] 53,11 x 43 x 9,2	G1 45°			A 442 053 00 32	<b>92-16127</b>
	EX [2] 53,11 x 43 x 9,7	G1 45°			A 403 053 00 32 A 403 053 03 32 A 403 053 21 32 A 403 053 25 32 A 403 053 28 32	<b>92-16104</b>
	EX [1] 53,11 x 43 x 9,2	G1 45°			A 422 053 01 32	<b>92-16126</b>
	EX [1] 53,31 x 43 x 9,4	G1 45°			A 442 053 01 32	<b>92-16149</b>
	EX [1] 53,31 x 43 x 9,9	G1 45°			A 403 053 01 32 A 403 053 13 32 A 403 053 22 32 A 403 053 26 32 A 403 053 29 32	<b>92-16148</b>
	EX [1] 53,51 x 43 x 10,2	G1 45°			A 403 053 02 32 A 403 053 23 32 A 403 053 27 32 A 403 053 30 32	<b>92-16105</b>
	EX [1] 53,51 x 43.2 x 9,6	G1 45°			A 442 053 02 32	<b>92-16128</b>
	724 mm				A 422 050 00 01 A 422 050 04 01 A 422 050 10 01 A 422 050 22 01	<b>20 1003 42201</b>
	[4] [1] [1]				A 403 050 07 33 A 442 050 03 33 A 403 050 03 33 A 403 050 07 33 A 442 050 03 33 A 403 050 03 33 A 403 050 07 33 A 442 050 03 33 A 442 055 00 20	<b>20 1002 25010</b> (1) <b>20 1003 40010</b> <b>20 1003 40012</b> (2)
	(1) nur 2-Ventiler/only 2 valves version/seulement 2 soupapes/sólo sistemas de 2 válvulas/заменяемо 2 Клапаны					
	(2) mit Einstellschraube/with adjusting screw/avec vis de réglage/con tornillo de ajuste/c установочным винтом					
	- - G - S -	- - - -			A 402 010 03 20 A 403 010 40 20 A 403 010 89 20 A 427 010 00 20 A 427 010 10 20 A 429 010 02 20 A 442 010 07 20	<b>20 0803 40300</b>
	- V - G - S -	- - - -	ready-to-install		A 427 010 10 20	<b>20 0803 40301</b>

M

					Reference	Item No.	
<b>477</b>		<b>128</b>					
<b>OM 427</b>	<b>902-500</b>	D (LA)	6	11970 cm <sup>3</sup>	2V	155,00 mm	
93 990 6..							
	IN [1]	59,0 x 12 x 142,5	A/S - Cr -	- 30° -	- 5 - III	A 403 053 09 01 A 422 050 00 26 A 422 050 02 26 A 422 050 05 26 A 422 053 01 01 A 423 050 00 26 A 442 050 02 26 A 442 050 03 26	<b>16117</b>
	IN [1]	59,0 x 12 x 142,5	A/S - Cr -	- 30° -	- 5 - III	A 442 050 05 26	<b>16146</b>
	EX [1]	51,0 x 12 x 142,5	RA/S- Cr -	- 45° -	- 5 - III	A 422 050 01 27 A 422 050 02 27 A 442 050 01 27 A 442 050 02 27 A 442 050 03 27 A 442 050 04 27	<b>16150</b>
	[50]	Ø 12 mm				A 422 053 00 26	<b>LK-1610</b>
	IN/EX [6]	18,03 x 12 x 67,0	G2			A 422 053 04 30	<b>81-16100</b>
	IN [2]	60,11 x 51.2 x 8,4	G1 30°			A 422 053 05 31	<b>92-16151</b>
	IN [1]	60,31 x 51.2 x 8,6	G1 30°			A 422 053 06 31	<b>92-16152</b>
	EX [2]	53,11 x 43 x 9,2	G1 45°			A 442 053 00 32	<b>92-16127</b>
	EX [1]	53,11 x 43 x 9,2	G1 45°			A 422 053 01 32	<b>92-16126</b>
	EX [1]	53,31 x 43 x 9,4	G1 45°			A 442 053 01 32	<b>92-16149</b>
	EX [1]	53,51 x 43.2 x 9,6	G1 45°			A 442 053 02 32	<b>92-16128</b>
	[12]	M 32 x 76 x 20				A 422 050 03 25 A 476 050 00 25	<b>20 1003 44000</b> (1)
	[12]	M 32 x 76 x 20				A 422 050 03 25 A 476 050 00 25	<b>20 1003 44001</b> <b>NEW</b> (2)
	(1)	OES specification					
	(2)	IAM specification					
	[4]					A 403 050 07 33 A 442 050 03 33	<b>20 1002 25010</b> (3)
	[1]					A 403 050 03 33 A 403 050 07 33 A 442 050 03 33	<b>20 1003 40010</b>
	[1]					A 403 050 03 33 A 403 050 07 33 A 442 050 03 33 A 442 055 00 20	<b>20 1003 40012</b> (4)
	(3)	nur 2-Ventiler/only 2 valves version/seulement 2 soupapes/sólo sistemas de 2 válvulas/заменяемо 2 Клапаны					
	(4)	mit Einstellschraube/with adjusting screw/avec vis de réglage/con tornillo de ajuste/c установочным винтом					

<b>478</b>		<b>128</b>				
<b>OM 427</b>	<b>903/-600</b>	D (A)	6	11970 cm <sup>3</sup>	2V	155,00 mm
<b>OM 427</b>	<b>902/-400</b>	D (LA)	6	11970 cm <sup>3</sup>	2V	155,00 mm
93 990 6..						

Fortsetzung nächste Seite / continued on next page / suite page suivante / continuación página próxima / Продолжение на следующей странице

					Reference	Item No.
	IN [1] 59,0 x 12 x 142,5	A/S - Cr -	- 30° - -	5 - III	A 403 053 09 01 A 422 050 00 26 A 422 050 02 26 A 422 050 05 26 A 422 053 01 01 A 423 050 00 26 A 442 050 02 26 A 442 050 03 26	<b>16117</b>
	IN [1] EX [1] 59,0 x 12 x 142,5 51,0 x 12 x 142,5	A/S - Cr - RA/S- Cr -	- 30° - - - 45° - -	5 - III 5 - III	A 442 050 05 26 A 422 050 01 27 A 422 050 02 27 A 442 050 01 27 A 442 050 02 27 A 442 050 03 27 A 442 050 04 27	<b>16146</b> <b>16150</b>
	[50] Ø 12 mm				A 422 053 00 26	<b>LK-1610</b>
	IN/EX [6] IN/EX [6] IN/EX [6] 18,03 x 12 x 67,0 18,03 x 12 x 67,0 18,23 x 12 x 67,0	G1 G2 G1			A 403 053 00 30 A 422 053 04 30 A 403 053 01 30	<b>81-1647</b> <b>81-16100</b> <b>81-1648</b>
	IN [2] IN [1] EX [2] EX [1] EX [1] EX [1] 60,11 x 51.2 x 8,4 60,31 x 51.2 x 8,6 53,11 x 43 x 9,2 53,11 x 43 x 9,2 53,31 x 43 x 9,4 53,51 x 43.2 x 9,6	G1 30° G1 30° G1 45° G1 45° G1 45° G1 45°			A 422 053 05 31 A 422 053 06 31 A 442 053 00 32 A 422 053 01 32 A 442 053 01 32 A 442 053 02 32	<b>92-16151</b> <b>92-16152</b> <b>92-16127</b> <b>92-16126</b> <b>92-16149</b> <b>92-16128</b>
	[12] [12] M 32 x 76 x 20 M 32 x 76 x 20				A 422 050 03 25 A 476 050 00 25 A 422 050 03 25 A 476 050 00 25	<b>20 1003 44000</b> (1) <b>20 1003 44001</b> <b>NEW</b> (2)
	(1) OES specification (2) IAM specification					
	[4] [1] [1] (3) nur 2-Ventiler/only 2 valves version/seulement 2 soupapes/sólo sistemas de 2 válvulas/заменяемо 2 Клапаны (4) mit Einstellschraube/with adjusting screw/avec vis de réglage/con tornillo de ajuste/c установочным винтом				A 403 050 07 33 A 442 050 03 33 A 403 050 03 33 A 403 050 07 33 A 442 050 03 33 A 403 050 03 33 A 403 050 07 33 A 442 050 03 33 A 442 055 00 20	<b>20 1002 25010</b> (3) <b>20 1003 40010</b> <b>20 1003 40012</b> (4)
Fortsetzung nächste Seite / continued on next page / suite page suivante / continuación página próxima / Продолжение на следующей странице						

M

					Reference	Item No.
	- - G - S -	- - -			A 402 010 03 20 A 403 010 40 20 A 403 010 89 20 A 427 010 00 20 A 427 010 10 20 A 429 010 02 20 A 442 010 07 20	<b>20 0803 40300</b>
		- V - G - S -	- - -	ready-to-install	A 427 010 10 20	<b>20 0803 40301</b>

**479** **128**
**OM 441**
**901**

D (LA) 6 10964 cm<sup>3</sup> 2V 250 kW (340 PS) 17,2:1 142,00 mm

90 220 6.., 91 630 6.., 94 331 7.., 94 512 6.., 99 973 6..

	IN [1]	59,0 x 12 x 142,5	A/S - Cr -	- 30° - -	5 - III	A 403 053 09 01 A 422 050 00 26 A 422 050 02 26 A 422 050 05 26 A 422 053 01 01 A 423 050 00 26 A 442 050 02 26 A 442 050 03 26	<b>16117</b>	
	IN [1] EX [2]	59,0 x 12 x 142,5 17,1 x 8 x 90,3	A/S - Cr - A - -	- 30° - - - 45° - -	5 - III 1 -	A 442 050 05 26 A 442 016 02 91 A 442 016 03 91	<b>16146</b> <b>50 004 665</b> (1)	
	EX [1]	51,0 x 12 x 142,5	RA/S- Cr -	- 45° - -	5 - III	A 422 050 01 27 A 422 050 02 27 A 442 050 01 27 A 442 050 02 27 A 442 050 03 27 A 442 050 04 27	<b>16150</b>	
	(1)	Konstantdrosselventil - Dom Exhaust brake valve - dome Papillon constant - Dôme Válvula de estrangulamiento constante - Dom Нерегулируемый дроссельный клапан - собор						
	[50]	Ø 12 mm				A 422 053 00 26	<b>LK-1610</b>	
	IN/EX [6]	18,03 x 12 x 67,0	G2			A 422 053 04 30	<b>81-16100</b>	
	IN [2] IN [2] IN [1] IN [1] EX [2] EX [1] EX [1] EX [1]	60,11 x 51.2 x 8,4 60,11 x 51.2 x 8,4 60,31 x 51.2 x 8,6 60,51 x 51.2 x 8,9 53,11 x 43 x 9,2 53,11 x 43 x 9,2 53,31 x 43 x 9,4 53,51 x 43.2 x 9,6	G1 G1 G1 G1 G1 G1 G1 G1	30° 45° 30° 30° 45° 45° 45° 45°		A 422 053 05 31 A 442 053 05 31 A 422 053 06 31 A 442 053 07 31 A 442 053 00 32 A 422 053 01 32 A 442 053 01 32 A 442 053 02 32	<b>92-16151</b> <b>92-16122</b> <b>92-16152</b> <b>92-16123</b> <b>92-16127</b> <b>92-16126</b> <b>92-16149</b> <b>92-16128</b>	

Fortsetzung nächste Seite / continued on next page / suite page suivante / continuación página próxima / Продолжение на следующей странице



					Reference	Item No.
	566 mm				A 401 050 19 01 A 401 050 22 01 A 441 050 17 01	<b>20 1003 40101</b>
	[4] [1] [1]				A 403 050 07 33 A 442 050 03 33 A 403 050 03 33 A 403 050 07 33 A 442 050 03 33 A 403 050 03 33 A 403 050 07 33 A 442 050 03 33 A 442 055 00 20	<b>20 1002 25010</b> (2) <b>20 1003 40010</b> <b>20 1003 40012</b> (3)
	(2) nur 2-Ventiler/only 2 valves version/seulement 2 soupapes/sólo sistemas de 2 válvulas/заменяемо 2 Клапаны (3) mit Einstellschraube/with adjusting screw/avec vis de réglage/con tornillo de ajuste/c установочным винтом					
	- - G - S -	- - -			A 402 010 03 20 A 403 010 40 20 A 403 010 89 20 A 427 010 00 20 A 427 010 10 20 A 429 010 02 20 A 442 010 07 20	<b>20 0803 40300</b>
	- V - G - S -	- - -	ready-to-install		A 427 010 10 20	<b>20 0803 40301</b>

## 480 128

OM 442 Euro 2 901-507

D (LA) 8 14618 cm<sup>3</sup> 2V

142,00 mm

94 681 6..

	IN [1]	59,0 x 12 x 142,5	A/S - Cr -	- 30° - -	5 - III	A 403 053 09 01 A 422 050 00 26 A 422 050 02 26 A 422 050 05 26 A 422 053 01 01 A 423 050 00 26 A 442 050 02 26 A 442 050 03 26	<b>16117</b>
	IN [1] EX [1]	59,0 x 12 x 142,5 51,0 x 12 x 142,5	A/S - Cr - RA/S- Cr -	- 30° - - - 45° - -	5 - III 5 - III	A 442 050 05 26 A 422 050 01 27 A 422 050 02 27 A 442 050 01 27 A 442 050 02 27 A 442 050 03 27 A 442 050 04 27	<b>16146</b> <b>16150</b>
	[50]	Ø 12 mm				A 422 053 00 26	<b>LK-1610</b>

Fortsetzung nächste Seite / continued on next page / suite page suivante / continuación página próxima / Продолжение на следующей странице

					Reference	Item No.
IN/EX [6]	18,03 x 12 x 67,0	G2			A 422 053 04 30	<b>81-16100</b>
IN [2]	60,11 x 51.2 x 8,4	G1 30°			A 422 053 05 31	<b>92-16151</b>
IN [1]	60,31 x 51.2 x 8,6	G1 30°			A 422 053 06 31	<b>92-16152</b>
EX [2]	53,11 x 43 x 9,2	G1 45°			A 442 053 00 32	<b>92-16127</b>
EX [1]	53,11 x 43 x 9,2	G1 45°			A 422 053 01 32	<b>92-16126</b>
EX [1]	53,31 x 43 x 9,4	G1 45°			A 442 053 01 32	<b>92-16149</b>
EX [1]	53,51 x 43.2 x 9,6	G1 45°			A 442 053 02 32	<b>92-16128</b>
	724 mm				A 442 050 08 01 A 442 050 11 01	<b>20 1003 44201</b>
[12]	M 31,5 x 76,5 x 20				A 403 054 09 01 A 403 054 18 01	<b>20 1003 40060</b>
[12]	M 32 x 76 x 20				A 422 050 03 25 A 476 050 00 25	<b>20 1003 44000</b> (1)
[12]	M 32 x 76 x 20				A 422 050 03 25 A 476 050 00 25	<b>20 1003 44001</b> <b>NEW</b> (2)
	(1) OES specification (2) IAM specification					
[4]					A 403 050 07 33 A 442 050 03 33	<b>20 1002 25010</b> (3)
[1]					A 403 050 03 33 A 403 050 07 33 A 442 050 03 33	<b>20 1003 40010</b>
[1]					A 403 050 03 33 A 403 050 07 33 A 442 050 03 33 A 442 055 00 20	<b>20 1003 40012</b> (4)
	(3) nur 2-Ventiler/only 2 valves version/seulement 2 soupapes/sólo sistemas de 2 válvulas/заменяемо 2 Клапаны (4) mit Einstellschraube/with adjusting screw/avec vis de réglage/con tornillo de ajuste/c установочным ВИНТОМ					
	- V - G - S -	- - - EVB	ready-to-install		A 442 010 06 20	<b>20 0803 44000</b>
	- - G - S -	- - -			A 442 010 06 20	<b>20 0803 44010</b>

**481**
**128**
**OM 442 Euro 0 974**

D (A) 8 14618 cm<sup>3</sup> 2V 269 kW (366 PS) 16,25:1 142,00 mm

90 220 6.., 91 630 6.., 94 512 6.., 99 973 6..

Fortsetzung nächste Seite / continued on next page / suite page suivante / continuación página próxima / Продолжение на следующей странице

					Reference	Item No.
	IN [1] 59,0 x 12 x 142,5	A/S - Cr -	- 30° - -	5 - III	A 403 053 09 01 A 422 050 00 26 A 422 050 02 26 A 422 050 05 26 A 422 053 01 01 A 423 050 00 26 A 442 050 02 26 A 442 050 03 26	<b>16117</b>
	IN [1] EX [1] 59,0 x 12 x 142,5 51,0 x 12 x 142,5	A/S - Cr - RA/S- Cr -	- 30° - - - 45° - -	5 - III 5 - III	A 442 050 05 26 A 422 050 01 27 A 422 050 02 27 A 442 050 01 27 A 442 050 02 27 A 442 050 03 27 A 442 050 04 27	<b>16146</b> <b>16150</b>
	[50] Ø 12 mm				A 422 053 00 26	<b>LK-1610</b>
	IN/EX [6] 18,03 x 12 x 67,0	G2			A 422 053 04 30	<b>81-16100</b>
	IN [2] IN [1] EX [2] EX [1] EX [1] EX [1] 60,11 x 51.2 x 8,4 60,31 x 51.2 x 8,6 53,11 x 43 x 9,2 53,11 x 43 x 9,2 53,31 x 43 x 9,4 53,51 x 43.2 x 9,6	G1 30° G1 30° G1 45° G1 45° G1 45° G1 45°			A 422 053 05 31 A 422 053 06 31 A 442 053 00 32 A 422 053 01 32 A 442 053 01 32 A 442 053 02 32	<b>92-16151</b> <b>92-16152</b> <b>92-16127</b> <b>92-16126</b> <b>92-16149</b> <b>92-16128</b>
	[4] [1] [1]				A 403 050 07 33 A 442 050 03 33 A 403 050 03 33 A 403 050 07 33 A 442 050 03 33 A 403 050 03 33 A 403 050 07 33 A 442 050 03 33 A 442 055 00 20	<b>20 1002 25010</b> (1) <b>20 1003 40010</b> <b>20 1003 40012</b> (2)
	(1) nur 2-Ventiler/only 2 valves version/seulement 2 soupapes/sólo sistemas de 2 válvulas/заменяемо 2 Клапаны					
	(2) mit Einstellschraube/with adjusting screw/avec vis de réglage/con tornillo de ajuste/c установочным винтом					

## 482 128

OM 447	900	D (NA)	6	11967 cm <sup>3</sup>	2V	147 kW	(200 PS)	155,00 mm
OM 447	901/-200	D	6	11970 cm <sup>3</sup>	2V			155,00 mm

	IN [1] 59,0 x 12 x 142,5	A/S - Cr -	- 30° - -	5 - III	A 403 053 09 01 A 422 050 00 26 A 422 050 02 26 A 422 050 05 26 A 422 053 01 01 A 423 050 00 26 A 442 050 02 26 A 442 050 03 26	<b>16117</b>
	IN [1] EX [1] EX [1] 59,0 x 12 x 142,5 51,0 x 12 x 142,5 51,0 x 12 x 142,5	A/S - Cr - A/S - Cr - RA/S- Cr -	- 30° - - - 45° - - - 45° - -	5 - III 5 - III 5 - III	A 442 050 05 26 A 422 050 00 27 A 422 050 02 27 A 442 050 01 27 A 442 050 02 27 A 442 050 03 27 A 442 050 04 27	<b>16146</b> <b>16116</b> <b>16150</b>

Fortsetzung nächste Seite / continued on next page / suite page suivante / continuación página próxima / Продолжение на следующей странице

					Reference	Item No.
[50]	Ø 12 mm				A 422 053 00 26	LK-1610
IN/EX [6]	18,03 x 12 x 67,0	G1			A 403 053 00 30	81-1647
IN/EX [6]	18,03 x 12 x 67,0	G2			A 422 053 04 30	81-16100
IN/EX [6]	18,23 x 12 x 67,0	G1			A 403 053 01 30	81-1648
IN [1]	60,11 x 49,3 x 8,4	G1 30°			A 422 053 01 31 A 447 053 00 31	92-16150
EX [2]	53,11 x 43 x 9,2	G1 45°			A 442 053 00 32	92-16127
EX [1]	53,11 x 43 x 9,2	G1 45°			A 422 053 01 32	92-16126
EX [1]	53,31 x 43 x 9,4	G1 45°			A 442 053 01 32	92-16149
EX [1]	53,51 x 43,2 x 9,6	G1 45°			A 442 053 02 32	92-16128
[12]	M 31,5 x 76,5 x 20				A 403 054 09 01 A 403 054 18 01	20 1003 40060
[12]	M 32 x 76 x 20				A 422 050 03 25 A 476 050 00 25	20 1003 44000 (1)
[12]	M 32 x 76 x 20				A 422 050 03 25 A 476 050 00 25	20 1003 44001 <b>NEW</b> (2)
	(1) OES specification					
	(2) IAM specification					
[4]					A 403 050 07 33 A 442 050 03 33	20 1002 25010 (3)
[1]					A 403 050 03 33 A 403 050 07 33	20 1003 40010
[1]					A 442 050 03 33 A 403 050 03 33 A 403 050 07 33 A 442 050 03 33 A 442 055 00 20	20 1003 40012 (4)
	(3) nur 2-Ventiler/only 2 valves version/seulement 2 soupapes/sólo sistemas de 2 válvulas/заменяемо 2 Клапаны					
	(4) mit Einstellschraube/with adjusting screw/avec vis de réglage/con tornillo de ajuste/с установочным винтом					

## 483 128

OM 447

902

D (A) 6 11967 cm<sup>3</sup> 2V 184 kW (250 PS) 16,6:1 155,00 mm

OM 485

980

D (LA) 5 9973 cm<sup>3</sup> 2V 221 kW (301 PS) 155,00 mm

93 990 6..

IN [1]	59,0 x 12 x 142,5	A/S - Cr -	- 30° - -	5 - III	A 403 053 09 01 A 422 050 00 26 A 422 050 02 26 A 422 050 05 26 A 422 053 01 01 A 423 050 00 26 A 442 050 02 26 A 442 050 03 26	16117
IN [1]	59,0 x 12 x 142,5	A/S - Cr -	- 30° - -	5 - III	A 442 050 05 26	16146
EX [1]	51,0 x 12 x 142,5	RA/S- Cr -	- 45° - -	5 - III	A 422 050 01 27 A 422 050 02 27 A 442 050 01 27 A 442 050 02 27 A 442 050 03 27 A 442 050 04 27	16150
[50]	Ø 12 mm				A 422 053 00 26	LK-1610
IN/EX [6]	18,03 x 12 x 67,0	G2			A 422 053 04 30	81-16100

Fortsetzung nächste Seite / continued on next page / suite page suivante / continuación página próxima / Продолжение на следующей странице

					Reference	Item No.
	IN [1] 60,11 x 49.3 x 8,4	G1 30°			A 422 053 01 31 A 447 053 00 31	<b>92-16150</b>
	EX [2] 53,11 x 43 x 9,2	G1 45°			A 442 053 00 32	<b>92-16127</b>
	EX [1] 53,11 x 43 x 9,2	G1 45°			A 422 053 01 32	<b>92-16126</b>
	EX [1] 53,31 x 43 x 9,4	G1 45°			A 442 053 01 32	<b>92-16149</b>
	EX [1] 53,51 x 43.2 x 9,6	G1 45°			A 442 053 02 32	<b>92-16128</b>
	[4]				A 403 050 07 33 A 442 050 03 33	<b>20 1002 25010</b> (1)
	[1]				A 403 050 03 33 A 403 050 07 33 A 442 050 03 33	<b>20 1003 40010</b>
	[1]				A 403 050 03 33 A 403 050 07 33 A 442 050 03 33 A 442 055 00 20	<b>20 1003 40012</b> (2)
	(1) nur 2-Ventiler/only 2 valves version/seulement 2 soupapes/sólo sistemas de 2 válvulas/заменяемо 2 Клапаны					
	(2) mit Einstellschraube/with adjusting screw/avec vis de réglage/con tornillo de ajuste/c установочным винтом					

**484**
**128**

<b>OM 447</b>	<b>902-400</b>	D (A)	6	11970 cm <sup>3</sup>	2V	155,00 mm
<b>OM 447</b>	<b>902-500</b>	D (LA)	6	11970 cm <sup>3</sup>	2V	155,00 mm
<b>OM 447 Euro 2</b>	<b>903-707</b>	D (LA)	6	11970 cm <sup>3</sup>	2V	155,00 mm

40 176 6..., 93 171 6..., 93 990 6..

	IN [1] 59,0 x 12 x 142,5	A/S - Cr -	- 30° -	-	5 - III	A 403 053 09 01 A 422 050 00 26 A 422 050 02 26 A 422 050 05 26 A 422 053 01 01 A 423 050 00 26 A 442 050 02 26 A 442 050 03 26	<b>16117</b>
	IN [1] 59,0 x 12 x 142,5	A/S - Cr -	- 30° -	-	5 - III	A 442 050 05 26	<b>16146</b>
	EX [1] 51,0 x 12 x 142,5	RA/S- Cr -	- 45° -	-	5 - III	A 422 050 01 27 A 422 050 02 27 A 442 050 01 27 A 442 050 02 27 A 442 050 03 27 A 442 050 04 27	<b>16150</b>
	[50]	Ø 12 mm				A 422 053 00 26	<b>LK-1610</b>
	IN/EX [6] 18,03 x 12 x 67,0	G1				A 403 053 00 30	<b>81-1647</b>
	IN/EX [6] 18,03 x 12 x 67,0	G2				A 422 053 04 30	<b>81-16100</b>
	IN/EX [6] 18,23 x 12 x 67,0	G1				A 403 053 01 30	<b>81-1648</b>
	IN [1] 60,11 x 49.3 x 8,4	G1 30°				A 422 053 01 31 A 447 053 00 31	<b>92-16150</b>
	EX [2] 53,11 x 43 x 9,2	G1 45°				A 442 053 00 32	<b>92-16127</b>
	EX [1] 53,31 x 43 x 9,4	G1 45°				A 442 053 01 32	<b>92-16149</b>
	EX [1] 53,51 x 43.2 x 9,6	G1 45°				A 442 053 02 32	<b>92-16128</b>
	[12]	M 31,5 x 76,5 x 20				A 403 054 09 01 A 403 054 18 01	<b>20 1003 40060</b>
	[12]	M 32 x 76 x 20				A 422 050 03 25 A 476 050 00 25	<b>20 1003 44000</b> (1)
	[12]	M 32 x 76 x 20				A 422 050 03 25 A 476 050 00 25	<b>20 1003 44001</b> <span style="border: 1px solid black; padding: 1px;">NEW</span> (2)
	(1) OES specification						

Fortsetzung nächste Seite / continued on next page / suite page suivante / continuación página próxima / Продолжение на следующей странице



					Reference	Item No.
(2)	IAM specification					
[4]					A 403 050 07 33 A 442 050 03 33	<b>20 1002 25010</b> (3)
[1]					A 403 050 03 33 A 403 050 07 33 A 442 050 03 33	<b>20 1003 40010</b>
[1]					A 403 050 03 33 A 403 050 07 33 A 442 050 03 33 A 442 055 00 20	<b>20 1003 40012</b> (4)
(3)	nur 2-Ventiler/only 2 valves version/seulement 2 soupapes/sólo sistemas de 2 válvulas/заменяемо 2 Клапаны					
(4)	mit Einstellschraube/with adjusting screw/avec vis de réglage/con tornillo de ajuste/c установочным ВИНТОМ					

## 485 128

<b>OM 447 Euro 1</b>	<b>903-604</b>	D (A)	6	11970 cm <sup>3</sup>	2V	18:1	155,00 mm
<b>OM 447 Euro 0</b>	<b>903-701</b>	D (LA)	6	11970 cm <sup>3</sup>	2V	16,25	155,00 mm
<b>OM 447 Euro 1</b>	<b>903-704</b>	D (LA)	6	11970 cm <sup>3</sup>	2V	18:1	155,00 mm

91 237 6.., 93 990 6..

M

IN [1]	59,0 x 12 x 142,5	A/S - Cr -	- 30° -	-	5 - III	A 403 053 09 01 A 422 050 00 26 A 422 050 02 26 A 422 050 05 26 A 422 053 01 01 A 423 050 00 26 A 442 050 02 26 A 442 050 03 26	<b>16117</b>
IN [1]	59,0 x 12 x 142,5	A/S - Cr -	- 30° -	-	5 - III	A 442 050 05 26	<b>16146</b>
EX [1]	51,0 x 12 x 142,5	RA/S- Cr -	- 45° -	-	5 - III	A 422 050 01 27 A 422 050 02 27 A 442 050 01 27 A 442 050 02 27 A 442 050 03 27 A 442 050 04 27	<b>16150</b>
[50]	Ø 12 mm					A 422 053 00 26	<b>LK-1610</b>
IN/EX [6]	18,03 x 12 x 67,0	G2				A 422 053 04 30	<b>81-16100</b>
IN [2]	60,11 x 51.2 x 8,4	G1 30°				A 422 053 05 31	<b>92-16151</b>
IN [1]	60,31 x 51.2 x 8,6	G1 30°				A 422 053 06 31	<b>92-16152</b>
EX [2]	53,11 x 43 x 9,2	G1 45°				A 442 053 00 32	<b>92-16127</b>
EX [1]	53,11 x 43 x 9,2	G1 45°				A 422 053 01 32	<b>92-16126</b>
EX [1]	53,31 x 43 x 9,4	G1 45°				A 442 053 01 32	<b>92-16149</b>
EX [1]	53,51 x 43.2 x 9,6	G1 45°				A 442 053 02 32	<b>92-16128</b>
[12]	M 31,5 x 76,5 x 20					A 403 054 09 01 A 403 054 18 01	<b>20 1003 40060</b>
[12]	M 32 x 76 x 20					A 422 050 03 25 A 476 050 00 25	<b>20 1003 44000</b> (1)
[12]	M 32 x 76 x 20					A 422 050 03 25 A 476 050 00 25	<b>20 1003 44001</b> <b>NEW</b> (2)
(1)	OES specification						
(2)	IAM specification						

Fortsetzung nächste Seite / continued on next page / suite page suivante / continuación página próxima / Продолжение на следующей странице

					Reference	Item No.	
[4]					A 403 050 07 33	20 1002 25010 (3)	
[1]					A 442 050 03 33	20 1003 40010	
[1]					A 403 050 03 33		
					A 403 050 07 33	20 1003 40012 (4)	
					A 442 050 03 33		
					A 403 050 03 33		
					A 442 050 03 33		
					A 442 055 00 20		
	(3)	nur 2-Ventiler/only 2 valves version/seulement 2 soupapes/sólo sistemas de 2 válvulas/заменяемо 2 Клапаны					
	(4)	mit Einstellschraube/with adjusting screw/avec vis de réglage/con tornillo de ajuste/c установочным винтом					

**486**
**128**
**OM 447**
**969-504 (USA)**

D (LA) 6 11970 cm<sup>3</sup> 2V 224 kW (300 PS) 155,00 mm

[1]					A 403 050 03 33	20 1003 40010	
[1]					A 403 050 07 33		
					A 442 050 03 33	20 1003 40012 (1)	
					A 403 050 03 33		
					A 403 050 07 33		
					A 442 050 03 33		
					A 442 055 00 20		
	(1)	mit Einstellschraube/with adjusting screw/avec vis de réglage/con tornillo de ajuste/c установочным винтом					

**487**
**128**
**OM 457 Euro 2/3**
**958**

D (LA) 6 11967 cm<sup>3</sup> 4V 230-315 kW (313-428 PS) 17,25:1 155,00 mm

**OM 460 Euro 3**
**960**

D (LA) 6 12816 cm<sup>3</sup> 4V 306 kW (416 PS) 18:1 166,00 mm

	IN [2]	45,5 x 9 x 144,9	RA/S- Cr -	- 30° - -	5 - III	A 457 053 00 01	160054
	IN [2]	45,5 x 9 x 145,0	S - Cr -	- 30° - -	5 - III	A 541 050 02 26	
	EX [2]	17,0 x 8 x 87,0	A - -	- 45° - -	9 -	A 460 053 00 01	261101 (1)
	EX [2]	41,0 x 9 x 145,0	RA/S- Cr -	- 45° - -	5 - III	A 541 053 01 01	
	EX [2]	41,0 x 9 x 145,0	RA/S- Cr -	- 45° - -	5 - III	A 541 016 05 91	160055
	EX [2]	42,1 x 9 x 145,0	RA/S- Cr -	- 36° - -	5 - III	A 541 016 06 91	
						A 541 016 07 91	16205
						A 541 050 01 27	
						A 541 050 02 27	
						A 457 050 03 27	
						A 457 050 05 27	
	(1)	Konstantdrosselventil - flach Exhaust brake valve - flat Soupape de réduction permanente - plate Válvula de reducción permanente - plana Постоянный дроссельный клапан					
	[50]	Ø 9 mm				A 541 053 00 26	LK-2615
						A 541 053 01 26	
						A 541 053 02 26	
	IN/EX [4]	15,03 x 9 x 61,0	G2			A 457 053 12 30	81-16103 (2)
	IN/EX [4]	15,24 x 9 x 61,0	G2			A 541 053 12 30	
						A 541 053 27 30	81-16104 (2)
						A 457 053 13 30	
						A 541 053 13 30	
						A 541 053 28 30	
	(2)	abweichend zu OE Bohrung fertigbearbeitet finish-machined with other than original bore usiné à un alésage différent de l'origine orificio mecanizado de manera diferente al original в отличие от OE отверстие расточено					

Fortsetzung nächste Seite / continued on next page / suite page suivante / continuación página próxima / Продолжение на следующей странице

					Reference	Item No.
	IN [2] 47,38 x 40 x 7,7	G1 30°			A 541 053 17 31 A 541 053 21 31 A 541 053 26 31	<b>92-16157</b>
	IN [2] EX [2] EX [1]	47,39 x 36.6 x 7,8 43,10 x 34 x 8,0 43,10 x 34.4 x 7,8	G1 30° G1 45° G1 36°		A 457 053 16 31 A 541 053 05 32 A 457 053 13 32	<b>92-16156</b> <b>92-16158</b> <b>92-16170</b> <small>NEW</small>
	(3) Flanschseite 6 x M10 Gewinde Flange 6x M10 thread La bride - le filet 6x M10 La brida - la rosca 6x M10 Фланцевая страница 6 x M10 резьба				A 457 050 23 01 A 457 050 30 01 A 460 050 01 01 A 460 050 04 01	<b>20 1003 46000</b> (3)
	[12] M 30 x 75				A 541 050 17 22 A 541 050 20 22	<b>20 1003 50062</b> <small>NEW</small> (4)
	(4) Mit 2 Ölbohrungen/with 2 oil holes/avec 2 trous d'huile/con 2 agujeros de aceite/c 2-мя смазочными отверстиями					
	I [1]				A 541 050 04 33 A 541 050 06 33 A 541 050 07 33 A 541 050 08 33 A 541 050 09 33 A 541 055 07 50	<b>20 1003 50010</b> (5)
	[1]				A 541 050 05 34 A 541 050 06 34 A 541 050 07 34 A 541 050 08 34	<b>20 1003 50011</b>
	(5) IN					

## 488 128

OM 457 Euro 4

982

D (LA) 6 11967 cm<sup>3</sup> 4V 295-315 kW (401-428 PS) 17,25:1 155,00 mm

OM 458

992

D (LA) 6 11967 cm<sup>3</sup> 4V 265-375 kW (360-510 PS) 18 155,00 mm

40 666 6..

	IN [2] EX [2]	45,5 x 9 x 145,0 M + 1 42,1 x 9 x 145,0	S - Cr - RA/S- Cr -	- 30° - - - 36° - -	5 - III 5 - III	A 460 053 00 01 A 541 053 01 01 A 457 050 03 27 A 457 050 05 27	<b>16204</b> <b>16205</b>
	[50]	∅ 9 mm				A 541 053 00 26 A 541 053 01 26 A 541 053 02 26	<b>LK-2615</b>
	IN/EX [4]	15,03 x 9 x 61,0	G2			A 457 053 12 30 A 541 053 12 30 A 541 053 27 30	<b>81-16103</b> (1)
	IN/EX [4]	15,24 x 9 x 61,0	G2			A 457 053 13 30 A 541 053 13 30 A 541 053 28 30	<b>81-16104</b> (1)
	(1) abweichend zu OE Bohrung fertigbearbeitet finish-machined with other than original bore usiné à un alésage différent de l'origine orificio mecanizado de manera diferente al original в отличие от OE отверстие расточено						

Fortsetzung nächste Seite / continued on next page / suite page suivante / continuación página próxima / Продолжение на следующей странице

					Reference	Item No.
	IN [2] 47,38 x 40 x 7,7	G1 30°			A 541 053 17 31 A 541 053 21 31 A 541 053 26 31	<b>92-16157</b>
	IN [2] 47,39 x 36.6 x 7,8	G1 30°			A 457 053 16 31	<b>92-16156</b>
	EX [2] 43,10 x 34 x 8,0	G1 45°			A 541 053 05 32	<b>92-16158</b>
	EX [1] 43,10 x 34.4 x 7,8	G1 36°			A 457 053 13 32	<b>92-16170</b> <small>NEW</small>
	[12] M 30 x 75				A 541 050 17 22 A 541 050 20 22	<b>20 1003 50062</b> <small>NEW</small> (2)
(2) Mit 2 Ölbohrungen/with 2 oil holes/avec 2 trous d'huile/con 2 agujeros de aceite/c 2-мя смазочными отверстиями						

**489**
**128**
**OM 457 Euro 4**
**984**

D (LA) 6 11967 cm<sup>3</sup> 4V 265 kW (360 PS) 17,25:1 155,00 mm

99 948 6..

	IN [2] 45,5 x 9 x 145,0 M + 1	S - Cr -	- 30° - -	5 - III	A 460 053 00 01 A 541 053 01 01	<b>16204</b>
	EX [2] 42,1 x 9 x 145,0	RA/S- Cr -	- 36° - -	5 - III	A 457 050 03 27 A 457 050 05 27	<b>16205</b>
	[50] Ø 9 mm				A 541 053 00 26 A 541 053 01 26 A 541 053 02 26	<b>LK-2615</b>
	IN/EX [4] 15,03 x 9 x 61,0	G2			A 457 053 12 30 A 541 053 12 30 A 541 053 27 30	<b>81-16103</b> (1)
	IN/EX [4] 15,24 x 9 x 61,0	G2			A 457 053 13 30 A 541 053 13 30 A 541 053 28 30	<b>81-16104</b> (1)
(1) abweichend zu OE Bohrung fertigbearbeitet finish-machined with other than original bore usiné à un alésage différent de l'origine orificio mecanizado de manera diferente al original в отличие от OE отверстие расточено						
	IN [2] 47,38 x 40 x 7,7	G1 30°			A 541 053 17 31 A 541 053 21 31 A 541 053 26 31	<b>92-16157</b>
	IN [2] 47,39 x 36.6 x 7,8	G1 30°			A 457 053 16 31	<b>92-16156</b>
	EX [2] 43,10 x 34 x 8,0	G1 45°			A 541 053 05 32	<b>92-16158</b>
	EX [1] 43,10 x 34.4 x 7,8	G1 36°			A 457 053 13 32	<b>92-16170</b> <small>NEW</small>
	1053 mm				A 457 050 31 01	<b>20 1003 45704</b>
	[12] M 30 x 75				A 541 050 03 22 A 541 050 05 22 A 541 050 07 22 A 541 050 13 22	<b>20 1003 50060</b> (2)
(2) Rollenstößel/roller tappet/poussoir à galet/empujador de rodillos/роликовый толкатель						

**490**
**128**
**OM 457 Euro 4/5**
**986**

D (LA) 6 11967 cm<sup>3</sup> 4V 185-335 kW (252-455 PS) 18,5:1 155,00 mm

40 666 6..

	IN [2] 45,5 x 9 x 145,0 M + 1	S - Cr -	- 30° - -	5 - III	A 460 053 00 01 A 541 053 01 01	<b>16204</b>
	EX [2] 17,0 x 8 x 87,0	A - -	- 45° - -	9 -	A 541 016 05 91 A 541 016 06 91 A 541 016 07 91	<b>261101</b> (1)
	EX [2] 42,1 x 9 x 145,0	RA/S- Cr -	- 36° - -	5 - III	A 457 050 03 27 A 457 050 05 27	<b>16205</b>
Fortsetzung nächste Seite / continued on next page / suite page suivante / continuación página próxima / Продолжение на следующей странице						

					Reference	Item No.
(1)	Konstantdrosselventil - flach Exhaust brake valve - flat Soupape de réduction permanente - plate Válvula de reducción permanente - plana Постоянный дроссельный клапан					
[50]	Ø 9 mm				A 541 053 00 26 A 541 053 01 26 A 541 053 02 26	<b>LK-2615</b>
IN/EX [4]	15,03 x 9 x 61,0	G2			A 457 053 12 30 A 541 053 12 30 A 541 053 27 30	<b>81-16103</b> (2)
(2)	abweichend zu OE Bohrung fertigbearbeitet finish-machined with other than original bore usiné à un alésage différent de l'origine orificio mecanizado de manera diferente al original в отличие от OE отверстие расточено					
IN [2]	47,38 x 40 x 7,7	G1 30°			A 541 053 17 31 A 541 053 21 31 A 541 053 26 31	<b>92-16157</b>
					A 460 050 06 01	<b>20 1003 46005</b>
[12]	M 30 x 75				A 541 050 17 22 A 541 050 20 22	<b>20 1003 50062</b> <small>NEW</small> (3)
(3)	Mit 2 Ölbohrungen/with 2 oil holes/avec 2 trous d'huile/con 2 agujeros de aceite/c 2-мя смазочными отверстиями					

## 491 128

OM 457 Euro 4/5 990 - 991

D (LA) 6 11967 cm<sup>3</sup> 4V 185-335 kW (252-455 PS) 18,5:1 155,00 mm

40 666 6..

					A 460 050 06 01	<b>20 1003 46005</b>
[12]	M 30 x 75				A 541 050 17 22 A 541 050 20 22	<b>20 1003 50062</b> <small>NEW</small> (1)
(1)	Mit 2 Ölbohrungen/with 2 oil holes/avec 2 trous d'huile/con 2 agujeros de aceite/c 2-мя смазочными отверстиями					

## 492 128

OM 458 Euro 2 910

D (LA) 6 11970 cm<sup>3</sup> 4V

155,00 mm

IN [2]	45,5 x 9 x 145,0 M + 1	S - Cr -	- 30° - -	5 - III	A 460 053 00 01 A 541 053 01 01	<b>16204</b>
EX [2]	42,1 x 9 x 145,0	RA/S- Cr -	- 36° - -	5 - III	A 457 050 03 27 A 457 050 05 27	<b>16205</b>
[50]	Ø 9 mm				A 541 053 00 26 A 541 053 01 26 A 541 053 02 26	<b>LK-2615</b>
IN/EX [4]	15,03 x 9 x 61,0	G2			A 457 053 12 30 A 541 053 12 30 A 541 053 27 30	<b>81-16103</b> (1)
IN/EX [4]	15,24 x 9 x 61,0	G2			A 457 053 13 30 A 541 053 13 30 A 541 053 28 30	<b>81-16104</b> (1)
(1)	abweichend zu OE Bohrung fertigbearbeitet finish-machined with other than original bore usiné à un alésage différent de l'origine orificio mecanizado de manera diferente al original в отличие от OE отверстие расточено					

Fortsetzung nächste Seite / continued on next page / suite page suivante / continuación página próxima / Продолжение на следующей странице



					Reference	Item No.
IN [2]	47,38 x 40 x 7,7	G1 30°			A 541 053 17 31 A 541 053 21 31 A 541 053 26 31	<b>92-16157</b>
IN [2]	47,39 x 36.6 x 7,8	G1 30°			A 457 053 16 31	<b>92-16156</b>
EX [2]	43,10 x 34 x 8,0	G1 45°			A 541 053 05 32	<b>92-16158</b>
EX [1]	43,10 x 34.4 x 7,8	G1 36°			A 457 053 13 32	<b>92-16170</b> <small>NEW</small>
	1053 mm				A 457 050 13 01	<b>20 1003 45700</b>
[12]	M 30 x 75				A 541 050 03 22 A 541 050 05 22 A 541 050 07 22 A 541 050 13 22	<b>20 1003 50060</b> (2)
	(2) Rollenstößel/roller tappet/poussoir à galet/empujador de rodillos/роликовый толкатель					
I [1]					A 541 050 04 33 A 541 050 06 33 A 541 050 07 33 A 541 050 08 33 A 541 050 09 33 A 541 055 07 50	<b>20 1003 50010</b> (3)
[1]					A 541 050 05 34 A 541 050 06 34 A 541 050 07 34 A 541 050 08 34	<b>20 1003 50011</b>
(3) IN						

## 493 128

**OM 460 Euro 3 906, 917, 920**

D (LA) 6 12816 cm<sup>3</sup> 4V 261-336 kW (355-457 PS) 18:1 166,00 mm

40 264 6..

IN [2]	45,5 x 9 x 144,9	RA/S- Cr -	- 30° - -	5 - III	A 457 053 00 01 A 541 050 02 26	<b>160054</b>
IN [2]	45,5 x 9 x 145,0 M + 1	S - Cr -	- 30° - -	5 - III	A 460 053 00 01 A 541 053 01 01	<b>16204</b>
EX [2]	17,0 x 8 x 87,0	A - -	- 45° - -	9 -	A 541 016 05 91 A 541 016 06 91 A 541 016 07 91	<b>261101</b> (1)
EX [2]	41,0 x 9 x 145,0	RA/S- Cr -	- 45° - -	5 - III	A 541 050 01 27 A 541 050 02 27	<b>160055</b>
EX [2]	42,1 x 9 x 145,0	RA/S- Cr -	- 36° - -	5 - III	A 457 050 03 27 A 457 050 05 27	<b>16205</b>
	(1) Konstantdrosselventil - flach Exhaust brake valve - flat Soupape de réduction permanente - plate Válvula de reducción permanente - plana Постоянный дроссельный клапан					
[50]	Ø 9 mm				A 541 053 00 26 A 541 053 01 26 A 541 053 02 26	<b>LK-2615</b>
IN/EX [4]	15,03 x 9 x 61,0	G2			A 457 053 12 30 A 541 053 12 30 A 541 053 27 30	<b>81-16103</b> (2)
IN/EX [4]	15,24 x 9 x 61,0	G2			A 457 053 13 30 A 541 053 13 30 A 541 053 28 30	<b>81-16104</b> (2)
	(2) abweichend zu OE Bohrung fertigbearbeitet finish-machined with other than original bore usiné à un alésage différent de l'origine orificio mecanizado de manera diferente al original в отличие от OE отверстие расточено					

Fortsetzung nächste Seite / continued on next page / suite page suivante / continuación página próxima / Продолжение на следующей странице

					Reference	Item No.
IN [2]	47,38 x 40 x 7,7	G1 30°			A 541 053 17 31 A 541 053 21 31 A 541 053 26 31	<b>92-16157</b>
EX [2]	43,10 x 34 x 8,0	G1 45°			A 541 053 05 32	<b>92-16158</b>
EX [1]	43,10 x 34.4 x 7,8	G1 36°			A 457 053 13 32	<b>92-16170</b> <small>NEW</small>
	(3) Flanschseite 6 x M10 Gewinde Flange 6x M10 thread La bride - le filet 6x M10 La brida - la rosca 6x M10 Фланцевая страница 6 x M10 резьба				A 457 050 23 01 A 457 050 30 01 A 460 050 01 01 A 460 050 04 01	<b>20 1003 46000</b> (3)
[12]	M 30 x 75				A 541 050 03 22 A 541 050 05 22 A 541 050 07 22 A 541 050 13 22	<b>20 1003 50060</b> (4)
	(4) Rollenstößel/roller tappet/poussoir à galet/empujador de rodillos/поликовый толкатель					
I [1]					A 541 050 04 33 A 541 050 06 33 A 541 050 07 33 A 541 050 08 33 A 541 050 09 33 A 541 055 07 50	<b>20 1003 50010</b> (5)
[1]					A 541 050 05 34 A 541 050 06 34 A 541 050 07 34 A 541 050 08 34	<b>20 1003 50011</b>
(5) IN						

**494**
**128**
**OM 460 Euro 3**
**926 - 927, 932 - 938**

D (LA) 6 12816 cm<sup>3</sup> 4V 261-336 kW (355-457 PS)

166,00 mm

41 857 6..

IN [2]	45,5 x 9 x 144,9	RA/S- Cr -	- 30° - -	5 - III	A 457 053 00 01 A 541 050 02 26	<b>160054</b>
IN [2]	45,5 x 9 x 145,0	S - Cr -	- 30° - -	5 - III	A 460 053 00 01 A 541 053 01 01	<b>16204</b>
EX [2]	17,0 x 8 x 87,0	A - -	- 45° - -	9 -	A 541 016 05 91 A 541 016 06 91 A 541 016 07 91	<b>261101</b> (1)
EX [2]	41,0 x 9 x 145,0	RA/S- Cr -	- 45° - -	5 - III	A 541 050 01 27 A 541 050 02 27	<b>160055</b>
EX [2]	42,1 x 9 x 145,0	RA/S- Cr -	- 36° - -	5 - III	A 457 050 03 27 A 457 050 05 27	<b>16205</b>
	(1) Konstantdrosselventil - flach Exhaust brake valve - flat Soupape de réduction permanente - plate Válvula de reducción permanente - plana Постоянный дроссельный клапан					
[50]	Ø 9 mm				A 541 053 00 26 A 541 053 01 26 A 541 053 02 26	<b>LK-2615</b>
IN/EX [4]	15,03 x 9 x 61,0	G2			A 457 053 12 30 A 541 053 12 30 A 541 053 27 30	<b>81-16103</b> (2)
IN/EX [4]	15,24 x 9 x 61,0	G2			A 457 053 13 30 A 541 053 13 30 A 541 053 28 30	<b>81-16104</b> (2)

Fortsetzung nächste Seite / continued on next page / suite page suivante / continuación página próxima / Продолжение на следующей странице

					Reference	Item No.
	(2)	abweichend zu OE Bohrung fertigbearbeitet finish-machined with other than original bore usiné à un alésage différent de l'origine orificio mecanizado de manera diferente al original в отличие от OE отверстие расточено				
	EX [1]	43,10 x 34.4 x 7,8	G1 36°		A 457 053 13 32	<b>92-16170</b>
					A 460 050 06 01	<b>20 1003 46005</b>
	[12]	M 30 x 75			A 541 050 03 22 A 541 050 05 22 A 541 050 07 22 A 541 050 13 22	<b>20 1003 50060</b> (3)
	(3)	Rollenstößel/roller tappet/poussoir à galet/empujador de rodillos/роликовый толкатель				
	I [1]				A 541 050 04 33 A 541 050 06 33 A 541 050 07 33 A 541 050 08 33 A 541 050 09 33 A 541 055 07 50	<b>20 1003 50010</b> (4)
	[1]				A 541 050 05 34 A 541 050 06 34 A 541 050 07 34 A 541 050 08 34	<b>20 1003 50011</b>
	(4)	IN				

**495**

**128**
**OM 460 Euro 3**
**939 - 949, 961**

D (LA) 6 12816 cm<sup>3</sup> 4V 261-336 kW (355-457 PS)

166,00 mm

41 857 6..

	IN [2]	45,5 x 9 x 145,0 M + 1	S - Cr -	- 30° - -	5 - III	A 460 053 00 01 A 541 053 01 01	<b>16204</b>
	EX [2]	42,1 x 9 x 145,0	RA/S- Cr -	- 36° - -	5 - III	A 457 050 03 27 A 457 050 05 27	<b>16205</b>
	[50]	Ø 9 mm				A 541 053 00 26 A 541 053 01 26 A 541 053 02 26	<b>LK-2615</b>
	IN/EX [4]	15,03 x 9 x 61,0	G2			A 457 053 12 30 A 541 053 12 30 A 541 053 27 30	<b>81-16103</b> (1)
	IN/EX [4]	15,24 x 9 x 61,0	G2			A 457 053 13 30 A 541 053 13 30 A 541 053 28 30	<b>81-16104</b> (1)
	(1)	abweichend zu OE Bohrung fertigbearbeitet finish-machined with other than original bore usiné à un alésage différent de l'origine orificio mecanizado de manera diferente al original в отличие от OE отверстие расточено					
	EX [1]	43,10 x 34.4 x 7,8	G1 36°			A 457 053 13 32	<b>92-16170</b>
						A 460 050 06 01	<b>20 1003 46005</b>
	[12]	M 30 x 75				A 541 050 03 22 A 541 050 05 22 A 541 050 07 22 A 541 050 13 22	<b>20 1003 50060</b> (2)
	(2)	Rollenstößel/roller tappet/poussoir à galet/empujador de rodillos/роликовый толкатель					

Fortsetzung nächste Seite / continued on next page / suite page suivante / continuación página próxima / Продолжение на следующей странице

					Reference	Item No.
I [1]					A 541 050 04 33 A 541 050 06 33 A 541 050 07 33 A 541 050 08 33 A 541 050 09 33 A 541 055 07 50	<b>20 1003 50010</b> (3)
[1]					A 541 050 05 34 A 541 050 06 34 A 541 050 07 34 A 541 050 08 34	<b>20 1003 50011</b>
(3) IN						

**496** **128**
**OM 460 Euro 3**
**950**

D (LA) 6 12816 cm<sup>3</sup> 4V 315-350 kW (428-476 PS) 18:1 166,00 mm

IN [2]	45,5 x 9 x 144,9	RA/S- Cr -	- 30° - - 5 - III	A 457 053 00 01 A 541 050 02 26	<b>160054</b>
IN [2]	45,5 x 9 x 145,0 M + 1	S - Cr -	- 30° - - 5 - III	A 460 053 00 01 A 541 053 01 01	<b>16204</b>
EX [2]	17,0 x 8 x 87,0	A - -	- 45° - - 9 -	A 541 016 05 91 A 541 016 06 91 A 541 016 07 91	<b>261101</b> (1)
EX [2]	41,0 x 9 x 145,0	RA/S- Cr -	- 45° - - 5 - III	A 541 050 01 27 A 541 050 02 27	<b>160055</b>
EX [2]	42,1 x 9 x 145,0	RA/S- Cr -	- 36° - - 5 - III	A 457 050 03 27 A 457 050 05 27	<b>16205</b>
(1) Konstantdrosselventil - flach Exhaust brake valve - flat Soupape de réduction permanente - plate Válvula de reducción permanente - plana Постоянный дроссельный клапан					
[50]	Ø 9 mm			A 541 053 00 26 A 541 053 01 26 A 541 053 02 26	<b>LK-2615</b>
IN/EX [4]	15,03 x 9 x 61,0	G2		A 457 053 12 30 A 541 053 12 30 A 541 053 27 30	<b>81-16103</b> (2)
IN/EX [4]	15,24 x 9 x 61,0	G2		A 457 053 13 30 A 541 053 13 30 A 541 053 28 30	<b>81-16104</b> (2)
(2) abweichend zu OE Bohrung fertigbearbeitet finish-machined with other than original bore usiné à un alésage différent de l'origine orificio mecanizado de manera diferente al original в отличие от OE отверстие расточено					
EX [1]	43,10 x 34.4 x 7,8	G1 36°		A 457 053 13 32	<b>92-16170</b> <b>NEW</b>
				A 457 050 23 01 A 457 050 30 01 A 460 050 01 01 A 460 050 04 01	<b>20 1003 46000</b> (3)
(3) Flanschseite 6 x M10 Gewinde Flange 6x M10 thread La bride - le filet 6x M10 La brida - la rosca 6x M10 Фланцевая страница 6 x M10 резьба					
[12]	M 30 x 75			A 541 050 17 22 A 541 050 20 22	<b>20 1003 50062</b> <b>NEW</b> (4)
(4) Mit 2 Ölbohrungen/with 2 oil holes/avec 2 trous d'huile/con 2 agujeros de aceite/c 2-мя смазочными отверстиями					

Fortsetzung nächste Seite / continued on next page / suite page suivante / continuación página próxima / Продолжение на следующей странице

					Reference	Item No.
	I [1]				A 541 050 04 33 A 541 050 06 33 A 541 050 07 33 A 541 050 08 33 A 541 050 09 33 A 541 055 07 50	20 1003 50010 (5)
	[1]				A 541 050 05 34 A 541 050 06 34 A 541 050 07 34 A 541 050 08 34	20 1003 50011
	(5) IN					

**497**

**128**
**OM 460 Euro 3**
**951**

D (LA) 6 12816 cm<sup>3</sup> 4V 315-360 kW (428-490 PS) 18:1 166,00 mm

40 726 6..

	IN [2]	45,5 x 9 x 144,9	RA/S- Cr -	- 30° - -	5 - III	A 457 053 00 01 A 541 050 02 26	160054	
	IN [2]	45,5 x 9 x 145,0 M + 1	S - Cr -	- 30° - -	5 - III	A 460 053 00 01 A 541 053 01 01	16204	
	EX [2]	17,0 x 8 x 87,0	A - -	- 45° - -	9 -	A 541 016 05 91 A 541 016 06 91 A 541 016 07 91	261101 (1)	
	EX [2]	41,0 x 9 x 145,0	RA/S- Cr -	- 45° - -	5 - III	A 541 050 01 27 A 541 050 02 27	160055	
	EX [2]	42,1 x 9 x 145,0	RA/S- Cr -	- 36° - -	5 - III	A 457 050 03 27 A 457 050 05 27	16205	
	(1)	Konstantdrosselventil - flach Exhaust brake valve - flat Soupape de réduction permanente - plate Válvula de reducción permanente - plana Постоянный дроссельный клапан						
	[50]	Ø 9 mm				A 541 053 00 26 A 541 053 01 26 A 541 053 02 26	LK-2615	
	IN/EX [4]	15,03 x 9 x 61,0	G2			A 457 053 12 30 A 541 053 12 30 A 541 053 27 30	81-16103 (2)	
	IN/EX [4]	15,24 x 9 x 61,0	G2			A 457 053 13 30 A 541 053 13 30 A 541 053 28 30	81-16104 (2)	
	(2)	abweichend zu OE Bohrung fertigbearbeitet finish-machined with other than original bore usiné à un alésage différent de l'origine orificio mecanizado de manera diferente al original в отличие от OE отверстие расточено						
	EX [1]	43,10 x 34.4 x 7,8	G1 36°			A 457 053 13 32	92-16170 <b>NEW</b>	
						A 460 050 06 01	20 1003 46005	
	[12]	M 30 x 75				A 541 050 17 22 A 541 050 20 22	20 1003 50062 <b>NEW</b> (3)	
	(3)	Mit 2 Ölbohrungen/with 2 oil holes/avec 2 trous d'huile/con 2 agujeros de aceite/c 2-мя смазочными отверстиями						
Fortsetzung nächste Seite / continued on next page / suite page suivante / continuación página próxima / Продолжение на следующей странице								

**M**



					Reference	Item No.
I [1]					A 541 050 04 33 A 541 050 06 33 A 541 050 07 33 A 541 050 08 33 A 541 050 09 33 A 541 055 07 50	20 1003 50010 (4)
[1]					A 541 050 05 34 A 541 050 06 34 A 541 050 07 34 A 541 050 08 34	20 1003 50011
(4) IN						
<b>498</b>		<b>128</b>				
OM 460 Euro 3	975 - 981	D (LA) 6	12816 cm <sup>3</sup> 4V	261-338 kW	(355-460 PS) 18:1	166,00 mm
IN [2]	45,5 x 9 x 144,9	RA/S- Cr -	- 30° - -	5 - III	A 457 053 00 01 A 541 050 02 26	160054
IN [2]	45,5 x 9 x 145,0 M + 1	S - Cr -	- 30° - -	5 - III	A 460 053 00 01 A 541 053 01 01	16204
EX [2]	17,0 x 8 x 87,0	A - -	- 45° - -	9 -	A 541 016 05 91 A 541 016 06 91 A 541 016 07 91	261101 (1)
EX [2]	41,0 x 9 x 145,0	RA/S- Cr -	- 45° - -	5 - III	A 541 050 01 27 A 541 050 02 27	160055
EX [2]	42,1 x 9 x 145,0	RA/S- Cr -	- 36° - -	5 - III	A 457 050 03 27 A 457 050 05 27	16205
(1)	Konstantdrosselventil - flach Exhaust brake valve - flat Soupape de réduction permanente - plate Válvula de reducción permanente - plana Постоянный дроссельный клапан					
[50]	Ø 9 mm				A 541 053 00 26 A 541 053 01 26 A 541 053 02 26	LK-2615
IN/EX [4]	15,03 x 9 x 61,0	G2			A 457 053 12 30 A 541 053 12 30 A 541 053 27 30	81-16103 (2)
IN/EX [4]	15,24 x 9 x 61,0	G2			A 457 053 13 30 A 541 053 13 30 A 541 053 28 30	81-16104 (2)
(2)	abweichend zu OE Bohrung fertigbearbeitet finish-machined with other than original bore usiné à un alésage différent de l'origine orificio mecanizado de manera diferente al original в отличие от OE отверстие расточено					
EX [1]	43,10 x 34.4 x 7,8	G1 36°			A 457 053 13 32	92-16170 <b>NEW</b>
I [1]					A 541 050 04 33 A 541 050 06 33 A 541 050 07 33 A 541 050 08 33 A 541 050 09 33 A 541 055 07 50	20 1003 50010 (3)
[1]					A 541 050 05 34 A 541 050 06 34 A 541 050 07 34 A 541 050 08 34	20 1003 50011
(3) IN						

M

					Reference	Item No.		
<b>499</b>		<b>128</b>						
<b>OM 475</b>	<b>907-505, 907-506</b>		D (LA) 5	9973 cm <sup>3</sup>	2V	221 kW (300 PS)	16,25:1 155,00 mm	
<b>OM 476</b>	<b>916-405, 916-406, 917-505, 917-506, 917-508</b>		D (A) 6	11970 cm <sup>3</sup>	2V	213-310 kW (290-422 PS)	155,00 mm	
	[12]	M 32 x 76 x 20				A 422 050 03 25 A 476 050 00 25	<b>20 1003 44000</b> (1)	
	(1)	OES specification						
<b>500</b>		<b>128</b>						
<b>OM 482</b>	<b>912</b>		D (NA) 8	14618 cm <sup>3</sup>	2V	206 kW (280 PS)	16,9:1 142,00 mm	
93 484 6.., 93 484 7..								
	IN [1] EX [1] EX [1]	59,0 x 12 x 142,5 51,0 x 12 x 142,5 51,0 x 12 x 142,5	A/S - Cr - A/S - Cr - RA/S- Cr -	- 30° - - 45° - - 45° -	- - -	5 - III 5 - III 5 - III	A 442 050 05 26 A 422 050 00 27 A 422 050 01 27 A 422 050 02 27 A 442 050 01 27 A 442 050 02 27 A 442 050 03 27 A 442 050 04 27	<b>16146</b> <b>16116</b> <b>16150</b>
	[50]	Ø 12 mm					A 422 053 00 26	<b>LK-1610</b>
	IN/EX [6]	18,03 x 12 x 67,0	G2				A 422 053 04 30	<b>81-16100</b>
	IN [2] IN [1] IN [1] EX [2]	60,11 x 51 x 8,9 60,31 x 51 x 9,1 60,51 x 51 x 9,3 53,11 x 43 x 9,7	G1 30° G1 30° G1 30° G1 45°				A 403 053 09 31 A 403 053 15 31 A 403 053 10 31 A 403 053 11 31 A 403 053 00 32 A 403 053 03 32 A 403 053 21 32 A 403 053 25 32 A 403 053 28 32	<b>92-16100</b> <b>92-16147</b> <b>92-16101</b> <b>92-16104</b>
	EX [1]	53,31 x 43 x 9,9	G1 45°				A 403 053 01 32 A 403 053 13 32 A 403 053 22 32 A 403 053 26 32 A 403 053 29 32	<b>92-16148</b>
	EX [1]	53,51 x 43 x 10,2	G1 45°				A 403 053 02 32 A 403 053 23 32 A 403 053 27 32 A 403 053 30 32	<b>92-16105</b>
		724 mm					A 422 050 01 01 A 422 050 03 01 A 422 050 05 01 A 422 050 21 01	<b>20 1003 42200</b>
	[12]	M 32 x 76 x 20					A 422 050 03 25 A 476 050 00 25	<b>20 1003 44000</b> (1)
	(1)	OES specification						
	[1]						A 403 050 03 33 A 403 050 07 33 A 442 050 03 33	<b>20 1003 40010</b>
	[1]						A 403 050 03 33 A 403 050 07 33 A 442 050 03 33 A 442 055 00 20	<b>20 1003 40012</b> (2)

Fortsetzung nächste Seite / continued on next page / suite page suivante / continuación página próxima / Продолжение на следующей странице

					Reference	Item No.
(2)	mit Einstellschraube/with adjusting screw/avec vis de réglage/con tornillo de ajuste/с установочным ВИНТОМ					
	- - G - S -	- - -			A 402 010 03 20 A 403 010 40 20 A 403 010 89 20 A 427 010 00 20 A 427 010 10 20 A 429 010 02 20 A 442 010 07 20	<b>20 0803 40300</b>
	- V - G - S -	- - -	ready-to-install		A 427 010 10 20	<b>20 0803 40301</b>

**M**
**501**
**128**
**OM 482**
**930**

D (NA) 8 14618 cm<sup>3</sup> 2V 206 kW (280 PS) 16,9:1 142,00 mm

93 484 6.., 93 484 7..

	IN [1]	59,0 x 12 x 142,5	A/S - Cr -	- 30° - -	5 - III	A 403 053 09 01 A 422 050 00 26 A 422 050 02 26 A 422 050 05 26 A 422 053 01 01 A 423 050 00 26 A 442 050 02 26 A 442 050 03 26	<b>16117</b>
	IN [1]	59,0 x 12 x 142,5	A/S - Cr -	- 30° - -	5 - III	A 442 050 05 26	<b>16146</b>
	EX [1]	51,0 x 12 x 142,5	RA/S- Cr -	- 45° - -	5 - III	A 422 050 01 27 A 422 050 02 27 A 442 050 01 27 A 442 050 02 27 A 442 050 03 27 A 442 050 04 27	<b>16150</b>
	[50]	Ø 12 mm				A 422 053 00 26	<b>LK-1610</b>
	IN/EX [6]	18,03 x 12 x 67,0	G2			A 422 053 04 30	<b>81-16100</b>

Fortsetzung nächste Seite / continued on next page / suite page suivante / continuación página próxima / Продолжение на следующей странице

					Reference	Item No.
IN [2]	60,11 x 51 x 8,9	G1 30°			A 403 053 09 31 A 403 053 15 31	<b>92-16100</b>
IN [1]	60,31 x 51 x 9,1	G1 30°			A 403 053 10 31	<b>92-16147</b>
IN [1]	60,51 x 51 x 9,3	G1 30°			A 403 053 11 31	<b>92-16101</b>
EX [2]	53,11 x 43 x 9,7	G1 45°			A 403 053 00 32 A 403 053 03 32 A 403 053 21 32 A 403 053 25 32 A 403 053 28 32	<b>92-16104</b>
EX [1]	53,31 x 43 x 9,9	G1 45°			A 403 053 01 32 A 403 053 13 32 A 403 053 22 32 A 403 053 26 32 A 403 053 29 32	<b>92-16148</b>
EX [1]	53,51 x 43 x 10,2	G1 45°			A 403 053 02 32 A 403 053 23 32 A 403 053 27 32 A 403 053 30 32	<b>92-16105</b>
	724 mm				A 422 050 01 01 A 422 050 03 01 A 422 050 05 01 A 422 050 21 01	<b>20 1003 42200</b>
[12]  (1) OES specification	M 32 x 76 x 20				A 422 050 03 25 A 476 050 00 25	<b>20 1003 44000</b> (1)
[1]  [1]					A 403 050 03 33 A 403 050 07 33 A 442 050 03 33 A 403 050 03 33 A 403 050 07 33 A 442 050 03 33 A 442 055 00 20	<b>20 1003 40010</b>  <b>20 1003 40012</b> (2)
					(2) mit Einstellschraube/with adjusting screw/avec vis de réglage/con tornillo de ajuste/c установочным винтом	
	- - G - S -	- - -			A 402 010 03 20 A 403 010 40 20 A 403 010 89 20 A 427 010 00 20 A 427 010 10 20 A 429 010 02 20 A 442 010 07 20	<b>20 0803 40300</b>
	- V - G - S -	- - -	ready-to-install		A 427 010 10 20	<b>20 0803 40301</b>

**502**

**128**
**OM 492**
**900-010, 900-013**
**D**
**8**
**14618 cm<sup>3</sup> 2V**
**206 kW**
**(280 PS) 16,9:1**
**142,00 mm**

93 484 6.., 93 484 7..

Fortsetzung nächste Seite / continued on next page / suite page suivante / continuación página próxima / Продолжение на следующей странице

					Reference	Item No.
IN [1]	59,0 x 12 x 142,5	A/S - Cr -	- 30° - -	5 - III	A 403 053 09 01 A 422 050 00 26 A 422 050 02 26 A 422 050 05 26 A 422 053 01 01 A 423 050 00 26 A 442 050 02 26 A 442 050 03 26	<b>16117</b>
IN [1]	59,0 x 12 x 142,5	A/S - Cr -	- 30° - -	5 - III	A 442 050 05 26	<b>16146</b>
EX [1]	51,0 x 12 x 142,5	RA/S- Cr -	- 45° - -	5 - III	A 422 050 01 27 A 422 050 02 27 A 442 050 01 27 A 442 050 02 27 A 442 050 03 27 A 442 050 04 27	<b>16150</b>
[50]	Ø 12 mm				A 422 053 00 26	<b>LK-1610</b>
IN/EX [6]	18,03 x 12 x 67,0	G2			A 422 053 04 30	<b>81-16100</b>
IN [2]	60,11 x 51 x 8,9	G1 30°			A 403 053 09 31 A 403 053 15 31	<b>92-16100</b>
IN [1]	60,31 x 51 x 9,1	G1 30°			A 403 053 10 31	<b>92-16147</b>
IN [1]	60,51 x 51 x 9,3	G1 30°			A 403 053 11 31	<b>92-16101</b>
EX [2]	53,11 x 43 x 9,7	G1 45°			A 403 053 00 32 A 403 053 03 32 A 403 053 21 32 A 403 053 25 32 A 403 053 28 32	<b>92-16104</b>
EX [1]	53,31 x 43 x 9,9	G1 45°			A 403 053 01 32 A 403 053 13 32 A 403 053 22 32 A 403 053 26 32 A 403 053 29 32	<b>92-16148</b>
EX [1]	53,51 x 43 x 10,2	G1 45°			A 403 053 02 32 A 403 053 23 32 A 403 053 27 32 A 403 053 30 32	<b>92-16105</b>
	724 mm				A 422 050 01 01 A 422 050 03 01 A 422 050 05 01 A 422 050 21 01	<b>20 1003 42200</b>
[1]					A 403 050 03 33 A 403 050 07 33	<b>20 1003 40010</b>
[1]					A 442 050 03 33 A 403 050 03 33 A 403 050 07 33 A 442 050 03 33 A 442 055 00 20	<b>20 1003 40012 (1)</b>
	(1) mit Einstellschraube/with adjusting screw/avec vis de réglage/con tornillo de ajuste/с установочным ВИНТОМ					

## 503 130

<b>OM 440 Euro 1</b>	<b>907</b> 01.1970 →	D (NA)	8	15078 cm <sup>3</sup>	2V	195 kW	(265 PS)	18:1	142,00 mm
<b>OM 441</b>	<b>906 - 907, 917</b> 08.1973 →	D	6	11309 cm <sup>3</sup>	2V	150-160 kW	(204-218 PS)	16,9:1	142,00 mm
<b>OM 441</b>	<b>908</b> 12.1987 → 09.1992	D (K)	6	11309 cm <sup>3</sup>	2V	160-165 kW	(218-224 PS)	16,9:1	142,00 mm
<b>OM 441</b>	<b>905, 909, 911 - 916, 918 - 921, 923 - 927</b> 08.1973 →	D (NA)	6	11309 cm <sup>3</sup>	2V	150-165 kW	(204-224 PS)	16,9:1	142,00 mm

Fortsetzung nächste Seite / continued on next page / suite page suivante / continuación página próxima / Продолжение на следующей странице



					Reference	Item No.	
<b>OM 441 Euro 1</b>	<b>922, 932 - 933</b>						
	12.1988 → 08.1994	D (NA) 6	11309 cm <sup>3</sup>	2V	151 kW (205 PS)	18:1 142,00 mm	
<b>OM 442 Euro 1</b>	<b>931</b>						
	09.1991 → 01.1992	D (NA) 8	15078 cm <sup>3</sup>	2V	195 kW (265 PS)	18:1 142,00 mm	
<b>OM 443</b>	<b>905</b>						
	01.1980 → 08.1994	D (NA) 10	18848 cm <sup>3</sup>	2V	271 kW (369 PS)	16,9:1 142,00 mm	
90 614 6.., 91 620 6..							
	IN [1]	59,0 x 12 x 142,5	A/S - Cr -	- 30° - -	5 - III	A 403 053 09 01 A 422 050 00 26 A 422 050 02 26 A 422 050 05 26 A 422 053 01 01 A 423 050 00 26 A 442 050 02 26 A 442 050 03 26	<b>16117</b>
	IN [1]	59,0 x 12 x 142,5	A/S - Cr -	- 30° - -	5 - III	A 442 050 05 26	<b>16146</b>
	EX [1]	51,0 x 12 x 142,5	A/S - Cr -	- 45° - -	5 - III	A 422 050 00 27	<b>16116</b>
	EX [1]	51,0 x 12 x 142,5	RA/S- Cr -	- 45° - -	5 - III	A 422 050 01 27 A 422 050 02 27 A 442 050 01 27 A 442 050 02 27 A 442 050 03 27 A 442 050 04 27	<b>16150</b>
	[50]	∅ 12 mm				A 422 053 00 26	<b>LK-1610</b>
	IN/EX [6]	18,03 x 12 x 67,0	G2			A 422 053 04 30	<b>81-16100</b>
	IN [2]	60,11 x 51 x 8,9	G1 30°			A 403 053 09 31 A 403 053 15 31	<b>92-16100</b>
	IN [1]	60,31 x 51 x 9,1	G1 30°			A 403 053 10 31	<b>92-16147</b>
	IN [1]	60,51 x 51 x 9,3	G1 30°			A 403 053 11 31	<b>92-16101</b>
	EX [2]	53,11 x 43 x 9,7	G1 45°			A 403 053 00 32 A 403 053 03 32 A 403 053 21 32 A 403 053 25 32 A 403 053 28 32	<b>92-16104</b>
	EX [1]	53,31 x 43 x 9,9	G1 45°			A 403 053 01 32 A 403 053 13 32 A 403 053 22 32 A 403 053 26 32 A 403 053 29 32	<b>92-16148</b>
	EX [1]	53,51 x 43 x 10,2	G1 45°			A 403 053 02 32 A 403 053 23 32 A 403 053 27 32 A 403 053 30 32	<b>92-16105</b>
	[12]	M 31,5 x 76,5 x 20				A 403 054 09 01 A 403 054 18 01	<b>20 1003 40060</b>
	[12]	M 32 x 76 x 20				A 422 050 03 25 A 476 050 00 25	<b>20 1003 44000</b> (1)
	[12]	M 32 x 76 x 20				A 422 050 03 25 A 476 050 00 25	<b>20 1003 44001</b> <b>NEW</b> (2)
	(1)	OES specification					
	(2)	IAM specification					
Fortsetzung nächste Seite / continued on next page / suite page suivante / continuación página próxima / Продолжение на следующей странице							

**M**

					Reference	Item No.
[4]					A 403 050 07 33	<b>20 1002 25010</b> (3)
[1]					A 442 050 03 33	
[1]					A 403 050 03 33	<b>20 1003 40010</b>
					A 403 050 07 33	
					A 442 050 03 33	
					A 403 050 03 33	
					A 403 050 07 33	<b>20 1003 40012</b> (4)
					A 442 050 03 33	
					A 442 055 00 20	
(3)	nur 2-Ventiler/only 2 valves version/seulement 2 soupapes/sólo sistemas de 2 válvulas/заменяемо 2 Клапаны					
(4)	mit Einstellschraube/with adjusting screw/avec vis de réglage/con tornillo de ajuste/с установочным ВИНТОМ					
	- - G - S -	- - -			A 402 010 03 20	<b>20 0803 40300</b>
					A 403 010 40 20	
					A 403 010 89 20	
					A 427 010 00 20	
					A 427 010 10 20	
					A 429 010 02 20	
					A 442 010 07 20	
					A 427 010 10 20	<b>20 0803 40301</b>
	- V - G - S -	- - -	ready-to-install			

M

**504** **130**

<b>OM 440</b>	<b>909</b>	12.1988 → 08.1994	D (NA)	8	15078 cm <sup>3</sup>	2V	195 kW	(265 PS)	16,9:1	142,00 mm
<b>OM 442</b>	<b>905 - 911, 914 - 930, 932 - 935, 939</b>	01.1980 →	D (NA)	8	15078 cm <sup>3</sup>	2V	191-218 kW	(260-296 PS)		142,00 mm
<b>OM 442 Euro 1</b>	<b>900-004</b>	1992 →	D	8	15080 cm <sup>3</sup>	2V				142,00 mm

90 614 6.., 91 620 6..

IN [1]	59,0 x 12 x 142,5	A/S - Cr -	- 30° -	-	5 - III	A 403 053 09 01	<b>16117</b>	
						A 422 050 00 26		
						A 422 050 02 26		
						A 422 050 05 26		
						A 422 053 01 01		
						A 423 050 00 26		
						A 442 050 02 26		
						A 442 050 03 26		
IN [1]	59,0 x 12 x 142,5	A/S - Cr -	- 30° -	-	5 - III	A 442 050 05 26		<b>16146</b>
EX [1]	51,0 x 12 x 142,5	A/S - Cr -	- 45° -	-	5 - III	A 422 050 00 27		<b>16116</b>
EX [1]	51,0 x 12 x 142,5	RA/S- Cr -	- 45° -	-	5 - III	A 422 050 01 27	<b>16150</b>	
						A 422 050 02 27		
						A 442 050 01 27		
						A 442 050 02 27		
						A 442 050 03 27		
						A 442 050 04 27		
[50]	Ø 12 mm					A 422 053 00 26	<b>LK-1610</b>	

Fortsetzung nächste Seite / continued on next page / suite page suivante / continuación página próxima / Продолжение на следующей странице

					Reference	Item No.
IN/EX [6]	18,03 x 12 x 67,0	G2			A 422 053 04 30	<b>81-16100</b>
IN [2]	60,11 x 51 x 8,9	G1 30°			A 403 053 09 31 A 403 053 15 31	<b>92-16100</b>
IN [1]	60,31 x 51 x 9,1	G1 30°			A 403 053 10 31	<b>92-16147</b>
IN [1]	60,51 x 51 x 9,3	G1 30°			A 403 053 11 31	<b>92-16101</b>
EX [2]	53,11 x 43 x 9,7	G1 45°			A 403 053 00 32 A 403 053 03 32 A 403 053 21 32 A 403 053 25 32 A 403 053 28 32	<b>92-16104</b>
EX [1]	53,31 x 43 x 9,9	G1 45°			A 403 053 01 32 A 403 053 13 32 A 403 053 22 32 A 403 053 26 32 A 403 053 29 32	<b>92-16148</b>
EX [1]	53,51 x 43 x 10,2	G1 45°			A 403 053 02 32 A 403 053 23 32 A 403 053 27 32 A 403 053 30 32	<b>92-16105</b>
	724 mm				A 422 050 01 01 A 422 050 03 01 A 422 050 05 01 A 422 050 21 01	<b>20 1003 42200</b>
[12]	M 31,5 x 76,5 x 20				A 403 054 09 01 A 403 054 18 01	<b>20 1003 40060</b>
[12]	M 32 x 76 x 20				A 422 050 03 25 A 476 050 00 25	<b>20 1003 44000</b> (1)
[12]	M 32 x 76 x 20				A 422 050 03 25 A 476 050 00 25	<b>20 1003 44001</b> <small>NEW</small> (2)
	(1) OES specification					
	(2) IAM specification					
[4]					A 403 050 07 33 A 442 050 03 33	<b>20 1002 25010</b> (3)
[1]					A 403 050 03 33 A 403 050 07 33 A 442 050 03 33	<b>20 1003 40010</b>
[1]					A 403 050 03 33 A 403 050 07 33 A 442 050 03 33 A 442 055 00 20	<b>20 1003 40012</b> (4)
	(3) nur 2-Ventiler/only 2 valves version/seulement 2 soupapes/sólo sistemas de 2 válvulas/заменяемо 2 Клапаны					
	(4) mit Einstellschraube/with adjusting screw/avec vis de réglage/con tornillo de ajuste/c установочным винтом					
Fortsetzung nächste Seite / continued on next page / suite page suivante / continuación página próxima / Продолжение на следующей странице						

**M**

					Reference	Item No.
	- - G - S -	- - -			A 402 010 03 20 A 403 010 40 20 A 403 010 89 20 A 427 010 00 20 A 427 010 10 20 A 429 010 02 20 A 442 010 07 20	<b>20 0803 40300</b>
	- V - G - S -	- - -	ready-to-install		A 427 010 10 20	<b>20 0803 40301</b>

**505**
**130**
**OM 463**
**900-010**

04.1986 →

D

10

 18848 cm<sup>3</sup> 2V

260-271 kW

(354-368 PS)

16,9:1 142,00 mm

90 614 6..

**M**

	IN [1]	59,0 x 12 x 142,5	A/S - Cr -	- 30° - -	5 - III	A 403 053 09 01 A 422 050 00 26 A 422 050 02 26 A 422 050 05 26 A 422 053 01 01 A 423 050 00 26 A 442 050 02 26 A 442 050 03 26	<b>16117</b>
	IN [1]	59,0 x 12 x 142,5	A/S - Cr -	- 30° - -	5 - III	A 442 050 05 26	<b>16146</b>
	EX [2]	17,1 x 8 x 90,3	A - -	- 45° - -	1 -	A 442 016 02 91 A 442 016 03 91	<b>50 004 665</b> (1)
	EX [1]	51,0 x 12 x 142,5	RA/S- Cr -	- 45° - -	5 - III	A 422 050 01 27 A 422 050 02 27 A 442 050 01 27 A 442 050 02 27 A 442 050 03 27 A 442 050 04 27	<b>16150</b>
		(1) Konstantdrosselventil - Dom Exhaust brake valve - dome Papillon constant - Dôme Válvula de estrangulamiento constante - Dom Нерегулируемый дроссельный клапан - собор					
	[50]	Ø 12 mm				A 422 053 00 26	<b>LK-1610</b>
	IN/EX [6]	18,03 x 12 x 67,0	G2			A 422 053 04 30	<b>81-16100</b>
	IN [2]	60,11 x 51.2 x 8,4	G1 30°			A 422 053 05 31	<b>92-16151</b>
	IN [1]	60,31 x 51.2 x 8,6	G1 30°			A 422 053 06 31	<b>92-16152</b>
	EX [2]	53,11 x 43 x 9,2	G1 45°			A 442 053 00 32	<b>92-16127</b>
	EX [1]	53,11 x 43 x 9,2	G1 45°			A 422 053 01 32	<b>92-16126</b>
	EX [1]	53,31 x 43 x 9,4	G1 45°			A 442 053 01 32	<b>92-16149</b>
	EX [1]	53,51 x 43.2 x 9,6	G1 45°			A 442 053 02 32	<b>92-16128</b>
Fortsetzung nächste Seite / continued on next page / suite page suivante / continuación página próxima / Продолжение на следующей странице							

					Reference	Item No.
	[1]				A 403 050 03 33	20 1003 40010
	[1]				A 403 050 07 33	20 1003 40012 (2)
					A 442 050 03 33	
					A 403 050 03 33	
					A 403 050 07 33	
					A 442 050 03 33	
					A 442 055 00 20	
	(2) mit Einstellschraube/with adjusting screw/avec vis de réglage/con tornillo de ajuste/c установочным винтом					

<b>506</b>		<b>130</b>
OM 442	900/-000	
90 614 6..	12.1987 →	
	D	
	8	15080 cm <sup>3</sup> 2V
		142,00 mm

	IN [1]	59,0 x 12 x 142,5	A/S - Cr -	- 30° -	-	5 - III	A 403 053 09 01	16117	
							A 422 050 00 26		
							A 422 050 02 26		
							A 422 050 05 26		
							A 422 053 01 01		
							A 423 050 00 26		
							A 442 050 02 26		
							A 442 050 03 26		
	IN [1]	59,0 x 12 x 142,5	A/S - Cr -	- 30° -	-	5 - III	A 442 050 05 26		16146
	EX [2]	17,1 x 8 x 90,3	A - -	- 45° -	-	1 -	A 442 016 02 91		50 004 665 (1)
							A 442 016 03 91		
	EX [1]	51,0 x 12 x 142,5	A/S - Cr -	- 45° -	-	5 - III	A 422 050 00 27	16116	
	EX [1]	51,0 x 12 x 142,5	RA/S- Cr -	- 45° -	-	5 - III	A 422 050 01 27	16150	
							A 422 050 02 27		
							A 442 050 01 27		
							A 442 050 02 27		
							A 442 050 03 27		
							A 442 050 04 27		
	(1) Konstantdrosselventil - Dom Exhaust brake valve - dome Papillon constant - Dôme Válvula de estrangulamiento constante - Dom Нерегулируемый дроссельный клапан - собор								

	[50]	Ø 12 mm					A 422 053 00 26	LK-1610
--	------	---------	--	--	--	--	-----------------	---------

	IN/EX [6]	18,03 x 12 x 67,0	G2				A 422 053 04 30	81-16100
--	-----------	-------------------	----	--	--	--	-----------------	----------

	IN [2]	60,11 x 51 x 8,9	G1 30°				A 403 053 09 31	92-16100
	IN [1]	60,31 x 51 x 9,1	G1 30°				A 403 053 15 31	92-16147
	IN [1]	60,51 x 51 x 9,3	G1 30°				A 403 053 10 31	92-16101
	EX [2]	53,11 x 43 x 9,7	G1 45°				A 403 053 11 31	92-16101
							A 403 053 00 32	92-16104
							A 403 053 03 32	
							A 403 053 21 32	
							A 403 053 25 32	
							A 403 053 28 32	
	EX [1]	53,31 x 43 x 9,9	G1 45°				A 403 053 28 32	92-16148
							A 403 053 01 32	
							A 403 053 13 32	
							A 403 053 22 32	
							A 403 053 26 32	
							A 403 053 29 32	
	EX [1]	53,51 x 43 x 10,2	G1 45°				A 403 053 02 32	92-16105
							A 403 053 23 32	
							A 403 053 27 32	
							A 403 053 30 32	

Fortsetzung nächste Seite / continued on next page / suite page suivante / continuación página próxima / Продолжение на следующей странице



					Reference	Item No.
	724 mm				A 422 050 01 01 A 422 050 03 01 A 422 050 05 01 A 422 050 21 01	<b>20 1003 42200</b>
	[12] M 31,5 x 76,5 x 20				A 403 054 09 01 A 403 054 18 01	<b>20 1003 40060</b>
	[12] M 32 x 76 x 20				A 422 050 03 25 A 476 050 00 25	<b>20 1003 44000</b> (2)
	[12] M 32 x 76 x 20				A 422 050 03 25 A 476 050 00 25	<b>20 1003 44001</b> <b>NEW</b> (3)
	(2) OES specification					
	(3) IAM specification					
	[4]				A 403 050 07 33 A 442 050 03 33	<b>20 1002 25010</b> (4)
	[1]				A 403 050 03 33 A 403 050 07 33 A 442 050 03 33	<b>20 1003 40010</b>
	[1]				A 403 050 03 33 A 403 050 07 33 A 442 050 03 33 A 442 055 00 20	<b>20 1003 40012</b> (5)
	(4) nur 2-Ventiler/only 2 valves version/seulement 2 soupapes/sólo sistemas de 2 válvulas/заменяемо 2 Клапаны					
	(5) mit Einstellschraube/with adjusting screw/avec vis de réglage/con tornillo de ajuste/c установочным ВИНТОМ					
	- - G - S -	- - -			A 402 010 03 20 A 403 010 40 20 A 403 010 89 20 A 427 010 00 20 A 427 010 10 20 A 429 010 02 20 A 442 010 07 20	<b>20 0803 40300</b>
	- V - G - S -	- - -	ready-to-install		A 427 010 10 20	<b>20 0803 40301</b>

M

**507**

**130**

**OM 441**

**900/-000**

1988 →

D

6 11309 cm<sup>3</sup> 2V

142,00 mm

**OM 441 Euro 1**

**900-004**

1993 →

D

6 11309 cm<sup>3</sup> 2V

142,00 mm

90 614 6.., 91 620 6..

Fortsetzung nächste Seite / continued on next page / suite page suivante / continuación página próxima / Продолжение на следующей странице

					Reference	Item No.
	IN [1] 59,0 x 12 x 142,5	A/S - Cr -	- 30° -	5 - III	A 403 053 09 01 A 422 050 00 26 A 422 050 02 26 A 422 050 05 26 A 422 053 01 01 A 423 050 00 26 A 442 050 02 26 A 442 050 03 26	<b>16117</b>
	IN [1] EX [1] EX [1] 59,0 x 12 x 142,5 51,0 x 12 x 142,5 51,0 x 12 x 142,5	A/S - Cr - A/S - Cr - RA/S- Cr -	- 30° - - 45° - - 45° -	5 - III 5 - III 5 - III	A 442 050 05 26 A 422 050 00 27 A 422 050 01 27 A 422 050 02 27 A 442 050 01 27 A 442 050 02 27 A 442 050 03 27 A 442 050 04 27	<b>16146</b> <b>16116</b> <b>16150</b>
	[50] Ø 12 mm				A 422 053 00 26	<b>LK-1610</b>
	IN/EX [6] 18,03 x 12 x 67,0	G2			A 422 053 04 30	<b>81-16100</b>
	IN [2] IN [1] IN [1] EX [2] 60,11 x 51 x 8,9 60,31 x 51 x 9,1 60,51 x 51 x 9,3 53,11 x 43 x 9,7	G1 30° G1 30° G1 30° G1 45°			A 403 053 09 31 A 403 053 15 31 A 403 053 10 31 A 403 053 11 31 A 403 053 00 32 A 403 053 03 32 A 403 053 21 32 A 403 053 25 32 A 403 053 28 32	<b>92-16100</b> <b>92-16147</b> <b>92-16101</b> <b>92-16104</b>
	EX [1] 53,31 x 43 x 9,9	G1 45°			A 403 053 01 32 A 403 053 13 32 A 403 053 22 32 A 403 053 26 32 A 403 053 29 32	<b>92-16148</b>
	EX [1] 53,51 x 43 x 10,2	G1 45°			A 403 053 02 32 A 403 053 23 32 A 403 053 27 32 A 403 053 30 32	<b>92-16105</b>
	[12] M 32 x 76 x 20				A 422 050 03 25 A 476 050 00 25	<b>20 1003 44000</b> (1)
	[12] M 32 x 76 x 20				A 422 050 03 25 A 476 050 00 25	<b>20 1003 44001</b> <b>NEW</b> (2)
	(1) OES specification (2) IAM specification					
	[4] [1] [1]				A 403 050 07 33 A 442 050 03 33 A 403 050 03 33 A 403 050 07 33 A 442 050 03 33 A 403 050 03 33 A 403 050 07 33 A 442 050 03 33 A 442 055 00 20	<b>20 1002 25010</b> (3) <b>20 1003 40010</b> <b>20 1003 40012</b> (4)
	(3) nur 2-Ventiler/only 2 valves version/seulement 2 soupapes/sólo sistemas de 2 válvulas/заменяемо 2 Клапаны					
	(4) mit Einstellschraube/with adjusting screw/avec vis de réglage/con tornillo de ajuste/c установочным винтом					
Fortsetzung nächste Seite / continued on next page / suite page suivante / continuación página próxima / Продолжение на следующей странице						

M

					Reference	Item No.
	- - G - S -	- - -			A 402 010 03 20 A 403 010 40 20 A 403 010 89 20 A 427 010 00 20 A 427 010 10 20 A 429 010 02 20 A 442 010 07 20	<b>20 0803 40300</b>
	- V - G - S -	- - -	ready-to-install		A 427 010 10 20	<b>20 0803 40301</b>

**508**
**130**
**OM 462**
**900-010, 900-011 (AFS), 900-012, 900-013 (AFS)**

07.1988 →

D

 8 15080 cm<sup>3</sup> 2V

195-203 kW

(265-276 PS)

16,9:1 142,00 mm

90 614 6..

**M**

	IN [1]	59,0 x 12 x 142,5	A/S - Cr -	- 30° - -	5 - III	A 403 053 09 01 A 422 050 00 26 A 422 050 02 26 A 422 050 05 26 A 422 053 01 01 A 423 050 00 26 A 442 050 02 26 A 442 050 03 26	<b>16117</b>
	IN [1]	59,0 x 12 x 142,5	A/S - Cr -	- 30° - -	5 - III	A 442 050 05 26	<b>16146</b>
	EX [1]	51,0 x 12 x 142,5	A/S - Cr -	- 45° - -	5 - III	A 422 050 00 27	<b>16116</b>
	EX [1]	51,0 x 12 x 142,5	RA/S- Cr -	- 45° - -	5 - III	A 422 050 01 27 A 422 050 02 27 A 442 050 01 27 A 442 050 02 27 A 442 050 03 27 A 442 050 04 27	<b>16150</b>
	[50]	Ø 12 mm				A 422 053 00 26	<b>LK-1610</b>
	IN/EX [6]	18,03 x 12 x 67,0	G2			A 422 053 04 30	<b>81-16100</b>

Fortsetzung nächste Seite / continued on next page / suite page suivante / continuación página próxima / Продолжение на следующей странице

					Reference	Item No.
	IN [2] 60,11 x 51 x 8,9	G1 30°			A 403 053 09 31 A 403 053 15 31	<b>92-16100</b>
	IN [2] 60,11 x 51.2 x 8,4	G1 30°			A 422 053 05 31	<b>92-16151</b>
	IN [1] 60,31 x 51 x 9,1	G1 30°			A 403 053 10 31	<b>92-16147</b>
	IN [1] 60,31 x 51.2 x 8,6	G1 30°			A 422 053 06 31	<b>92-16152</b>
	IN [1] 60,51 x 51 x 9,3	G1 30°			A 403 053 11 31	<b>92-16101</b>
	EX [2] 53,11 x 43 x 9,7	G1 45°			A 403 053 00 32 A 403 053 03 32 A 403 053 21 32 A 403 053 25 32 A 403 053 28 32	<b>92-16104</b>
	EX [1] 53,31 x 43 x 9,9	G1 45°			A 403 053 01 32 A 403 053 13 32 A 403 053 22 32 A 403 053 26 32 A 403 053 29 32	<b>92-16148</b>
	EX [1] 53,51 x 43 x 10,2	G1 45°			A 403 053 02 32 A 403 053 23 32 A 403 053 27 32 A 403 053 30 32	<b>92-16105</b>
	[1]				A 403 050 03 33 A 403 050 07 33 A 442 050 03 33	<b>20 1003 40010</b>
	[1]				A 403 050 03 33 A 403 050 07 33 A 442 050 03 33 A 442 055 00 20	<b>20 1003 40012 (1)</b>
	(1) mit Einstellschraube/with adjusting screw/avec vis de réglage/con tornillo de ajuste/с установочным винтом					
<b>509</b>		<b>130</b>				
<b>OM 443</b>	<b>900</b>					
90 614 6..	08.1989 →	D (NA) 10	18848 cm <sup>3</sup> 2V	331 kW	(450 PS)	142,00 mm
	IN [1] 59,0 x 12 x 142,5	A/S - Cr -	- 30° - -	5 - III	A 403 053 09 01 A 422 050 00 26 A 422 050 02 26 A 422 050 05 26 A 422 053 01 01 A 423 050 00 26 A 442 050 02 26 A 442 050 03 26	<b>16117</b>
	IN [1] 59,0 x 12 x 142,5	A/S - Cr -	- 30° - -	5 - III	A 442 050 05 26	<b>16146</b>
	EX [1] 51,0 x 12 x 142,5	A/S - Cr -	- 45° - -	5 - III	A 422 050 00 27	<b>16116</b>
	EX [1] 51,0 x 12 x 142,5	RA/S- Cr -	- 45° - -	5 - III	A 422 050 01 27 A 422 050 02 27 A 442 050 01 27 A 442 050 02 27 A 442 050 03 27 A 442 050 04 27	<b>16150</b>
	[50] Ø 12 mm				A 422 053 00 26	<b>LK-1610</b>
	IN/EX [6] 18,03 x 12 x 67,0	G2			A 422 053 04 30	<b>81-16100</b>
Fortsetzung nächste Seite / continued on next page / suite page suivante / continuación página próxima / Продолжение на следующей странице						

**M**

					Reference	Item No.
	IN [2]	60,11 x 51 x 8,9	G1 30°		A 403 053 09 31 A 403 053 15 31	<b>92-16100</b>
	IN [1]	60,31 x 51 x 9,1	G1 30°		A 403 053 10 31	<b>92-16147</b>
	IN [1]	60,51 x 51 x 9,3	G1 30°		A 403 053 11 31	<b>92-16101</b>
	EX [2]	53,11 x 43 x 9,7	G1 45°		A 403 053 00 32 A 403 053 03 32 A 403 053 21 32 A 403 053 25 32 A 403 053 28 32	<b>92-16104</b>
	EX [1]	53,31 x 43 x 9,9	G1 45°		A 403 053 01 32 A 403 053 13 32 A 403 053 22 32 A 403 053 26 32 A 403 053 29 32	<b>92-16148</b>
EX [1]	53,51 x 43 x 10,2	G1 45°		A 403 053 02 32 A 403 053 23 32 A 403 053 27 32 A 403 053 30 32	<b>92-16105</b>	
	[12]	M 31,5 x 76,5 x 20			A 403 054 09 01 A 403 054 18 01	<b>20 1003 40060</b>
	[12]	M 32 x 76 x 20			A 422 050 03 25 A 476 050 00 25	<b>20 1003 44000</b> (1)
	[12]	M 32 x 76 x 20			A 422 050 03 25 A 476 050 00 25	<b>20 1003 44001</b> <b>NEW</b> (2)
	(1) OES specification (2) IAM specification					
	[1]				A 403 050 03 33 A 403 050 07 33 A 442 050 03 33	<b>20 1003 40010</b>
	[1]				A 403 050 03 33 A 403 050 07 33 A 442 050 03 33 A 442 055 00 20	<b>20 1003 40012</b> (3)
	(3) mit Einstellschraube/with adjusting screw/avec vis de réglage/con tornillo de ajuste/с установочным ВИНТОМ					
	- - G - S -	- - -			A 402 010 03 20 A 403 010 40 20 A 403 010 89 20 A 427 010 00 20 A 427 010 10 20 A 429 010 02 20 A 442 010 07 20	<b>20 0803 40300</b>
	- V - G - S -	- - -	ready-to-install		A 427 010 10 20	<b>20 0803 40301</b>

M



					Reference	Item No.
<b>510</b>		<b>130</b>				
<b>OM 522 Euro 2</b>	<b>950</b>	06.1996 →	D (LA) 8	15928 cm <sup>3</sup> 4V	530 kW (721 PS)	17,25:1 150,00 mm
<b>OM 542 Euro 3</b>	<b>956 - 958</b>	10.2002 →	D (LA) 8	15928 cm <sup>3</sup> 4V	448-450 kW (609-612 PS)	17,25:1 150,00 mm
40 448 6.., 40 463 6..						
	IN [2]	45,5 x 9 x 144,9	RA/S- Cr -	- 30° - -	5 - III	A 457 053 00 01 A 541 050 02 26 <b>160054</b>
	IN [2]	45,5 x 9 x 145,0 M + 1	S - Cr -	- 30° - -	5 - III	A 460 053 00 01 A 541 053 01 01 <b>16204</b>
	EX [2]	17,0 x 8 x 87,0	A - -	- 45° - -	9 -	A 541 016 05 91 A 541 016 06 91 A 541 016 07 91 <b>261101</b> (1)
	EX [2]	41,0 x 9 x 145,0	RA/S- Cr -	- 45° - -	5 - III	A 541 050 01 27 A 541 050 02 27 <b>160055</b>
	EX [2]	42,1 x 9 x 145,0	RA/S- Cr -	- 36° - -	5 - III	A 457 050 03 27 A 457 050 05 27 <b>16205</b>
	(1) Konstantdrosselventil - flach Exhaust brake valve - flat Soupape de réduction permanente - plate Válvula de reducción permanente - plana Постоянный дроссельный клапан					
	[50]	∅ 9 mm				A 541 053 00 26 A 541 053 01 26 A 541 053 02 26 <b>LK-2615</b>
	IN/EX [4]	15,03 x 9 x 61,0	G2			A 457 053 12 30 A 541 053 12 30 A 541 053 27 30 <b>81-16103</b> (2)
	IN/EX [4]	15,24 x 9 x 61,0	G2			A 457 053 13 30 A 541 053 13 30 A 541 053 28 30 <b>81-16104</b> (2)
	(2) abweichend zu OE Bohrung fertiggearbeitet finish-machined with other than original bore usiné à un alésage différent de l'origine orificio mecanizado de manera diferente al original в отличие от OE отверстие расточено					
	IN [2]	47,38 x 40 x 7,7	G1 30°			A 541 053 17 31 A 541 053 21 31 A 541 053 26 31 <b>92-16157</b>
	EX [2]	43,10 x 34 x 8,0	G1 45°			A 541 053 05 32 <b>92-16158</b>
	EX [1]	43,10 x 34.4 x 7,8	G1 36°			A 457 053 13 32 <b>92-16170</b> <small>NEW</small>
		779,5 mm - 8,3 mm				A 542 050 14 01 <b>20 1003 50201</b>
	[12]	M 30 x 75				A 541 050 03 22 A 541 050 05 22 A 541 050 07 22 A 541 050 13 22 <b>20 1003 50060</b> (3)
	[12]	M 30 x 75				A 541 050 17 22 A 541 050 20 22 <b>20 1003 50062</b> <small>NEW</small> (4)
	(3) Rollenstößel/roller tappet/poussoir à galet/empujador de rodillos/роликовый толкатель					
	(4) Mit 2 Ölbohrungen/with 2 oil holes/avec 2 trous d'huile/con 2 agujeros de aceite/c 2-мя смазочными отверстиями					
Fortsetzung nächste Seite / continued on next page / suite page suivante / continuación página próxima / Продолжение на следующей странице						

**M**

					Reference	Item No.
I [1]					A 541 050 04 33 A 541 050 06 33 A 541 050 07 33 A 541 050 08 33 A 541 050 09 33 A 541 055 07 50 A 541 050 05 34 A 541 050 06 34 A 541 050 07 34 A 541 050 08 34	<b>20 1003 50010</b> (5)  <b>20 1003 50011</b>
[1]						
(5) IN						
	- - G - S -	- - -			A 541 010 37 21 A 541 010 50 20 A 541 010 64 20	<b>20 0803 50100</b> (6)
	- V - G - S -	- - -	- EVB	ready-to-install	A 541 010 37 21 A 541 010 50 20 A 541 010 64 20	<b>20 0803 50101</b> (6)
(6)	Schutzhülse/Injector sleeve/puits d'injecteur/casquillo de protección/защитная гильза Ø 9,6 mm					

## 511 130

OM 542 Euro 2/3

947

02.1995 →

D (LA) 8 15928 cm<sup>3</sup> 4V 390-420 kW (530-571 PS) 17,25:1 150,00 mm

40 448 6.., 40 463 6..

	IN [2]	45,5 x 9 x 144,9	RA/S- Cr -	- 30° - -	5 - III	A 457 053 00 01 A 541 050 02 26	<b>160054</b>
	IN [2]	45,5 x 9 x 145,0 M + 1	S - Cr -	- 30° - -	5 - III	A 460 053 00 01 A 541 053 01 01	<b>16204</b>
	EX [2]	17,0 x 8 x 87,0	A - -	- 45° - -	9 -	A 541 016 05 91 A 541 016 06 91 A 541 016 07 91	<b>261101</b> (1)
	EX [2]	41,0 x 9 x 145,0	RA/S- Cr -	- 45° - -	5 - III	A 541 050 01 27 A 541 050 02 27	<b>160055</b>
	EX [2]	42,1 x 9 x 145,0	RA/S- Cr -	- 36° - -	5 - III	A 457 050 03 27 A 457 050 05 27	<b>16205</b>
	(1) Konstantdrosselventil - flach Exhaust brake valve - flat Soupape de réduction permanente - plate Válvula de reducción permanente - plana Постоянный дроссельный клапан						
	[50]	Ø 9 mm				A 541 053 00 26 A 541 053 01 26 A 541 053 02 26	<b>LK-2615</b>
	IN/EX [4]	15,03 x 9 x 61,0	G2			A 457 053 12 30 A 541 053 12 30 A 541 053 27 30	<b>81-16103</b> (2)
	IN/EX [4]	15,24 x 9 x 61,0	G2			A 457 053 13 30 A 541 053 13 30 A 541 053 28 30	<b>81-16104</b> (2)

Fortsetzung nächste Seite / continued on next page / suite page suivante / continuación página próxima / Продолжение на следующей странице

					Reference	Item No.
	(2) abweichend zu OE Bohrung fertigbearbeitet finish-machined with other than original bore usiné à un alésage différent de l'origine orificio mecanizado de manera diferente al original в отличие от OE отверстия расточено					
	IN [2] 47,38 x 40 x 7,7	G1 30°			A 541 053 17 31 A 541 053 21 31 A 541 053 26 31	<b>92-16157</b>
	EX [2] 43,10 x 34 x 8,0	G1 45°			A 541 053 05 32	<b>92-16158</b>
	EX [1] 43,10 x 34.4 x 7,8	G1 36°			A 457 053 13 32	<b>92-16170</b> <small>NEW</small>
	779,5 mm - 8,3 mm				A 542 050 14 01	<b>20 1003 50201</b>
	[12] M 30 x 75				A 541 050 03 22 A 541 050 05 22 A 541 050 07 22 A 541 050 13 22	<b>20 1003 50060</b> (3)
	[12] M 30 x 75				A 541 050 17 22 A 541 050 20 22	<b>20 1003 50062</b> <small>NEW</small> (4)
	(3) Rollenstößel/roller tappet/poussoir à galet/empujador de rodillos/роликовый толкатель					
	(4) Mit 2 Ölbohrungen/with 2 oil holes/avec 2 trous d'huile/con 2 agujeros de aceite/c 2-мя смазочными отверстиями					
	I [1]				A 541 050 04 33 A 541 050 06 33 A 541 050 07 33 A 541 050 08 33 A 541 050 09 33 A 541 055 07 50	<b>20 1003 50010</b> (5)
	[1]				A 541 050 05 34 A 541 050 06 34 A 541 050 07 34 A 541 050 08 34	<b>20 1003 50011</b>
	(5) IN					

## 512 130

<b>OM 521 Euro 2</b>	<b>940</b>	01.1996 →	D (LA)	6	11946 cm <sup>3</sup>	4V	315 kW	(428 PS)	17,25:1	150,00 mm
<b>OM 541 Euro 2/3</b>	<b>951</b>	01.1996 →	D (LA)	6	11946 cm <sup>3</sup>	4V	230-235 kW	(313-320 PS)	17,25:1	150,00 mm
<b>OM 541 Euro 3</b>	<b>948 - 949</b>	10.1996 →	D (LA)	6	11946 cm <sup>3</sup>	4V	335-355 kW	(456-483 PS)	17,25:1	150,00 mm

40 448 6..., 40 463 6..

	IN [2] 45,5 x 9 x 144,9	RA/S- Cr -	- 30° -	-	5 - III	A 457 053 00 01 A 541 050 02 26	<b>160054</b>
	IN [2] 45,5 x 9 x 145,0	S - Cr -	- 30° -	-	5 - III	A 460 053 00 01 A 541 053 01 01	<b>16204</b>
	EX [2] 17,0 x 8 x 87,0	A - -	- 45° -	-	9 -	A 541 016 05 91 A 541 016 06 91 A 541 016 07 91	<b>261101</b> (1)
	EX [2] 41,0 x 9 x 145,0	RA/S- Cr -	- 45° -	-	5 - III	A 541 050 01 27 A 541 050 02 27	<b>160055</b>
	EX [2] 42,1 x 9 x 145,0	RA/S- Cr -	- 36° -	-	5 - III	A 457 050 03 27 A 457 050 05 27	<b>16205</b>
	(1) Konstantdrosselventil - flach Exhaust brake valve - flat Soupape de réduction permanente - plate Válvula de reducción permanente - plana Постоянный дроссельный клапан						
	[50] Ø 9 mm					A 541 053 00 26 A 541 053 01 26 A 541 053 02 26	<b>LK-2615</b>

Fortsetzung nächste Seite / continued on next page / suite page suivante / continuación página próxima / Продолжение на следующей странице

					Reference	Item No.
	IN/EX [4] 15,03 x 9 x 61,0	G2			A 457 053 12 30 A 541 053 12 30 A 541 053 27 30	<b>81-16103</b> (2)
	IN/EX [4] 15,24 x 9 x 61,0	G2			A 457 053 13 30 A 541 053 13 30 A 541 053 28 30	<b>81-16104</b> (2)
	(2) abweichend zu OE Bohrung fertiggearbeitet finish-machined with other than original bore usiné à un alésage différent de l'origine orificio mecanizado de manera diferente al original в отличие от OE отверстие расточено					
	IN [2] 47,38 x 40 x 7,7	G1 30°			A 541 053 17 31 A 541 053 21 31 A 541 053 26 31	<b>92-16157</b>
	EX [2] 43,10 x 34 x 8,0	G1 45°			A 541 053 05 32	<b>92-16158</b>
	EX [1] 43,10 x 34.4 x 7,8	G1 36°			A 457 053 13 32	<b>92-16170</b> <small>NEW</small>
	613,5 mm				A 541 050 16 01 A 541 050 18 01	<b>20 1003 50101</b>
	[12] M 30 x 75				A 541 050 03 22 A 541 050 05 22 A 541 050 07 22 A 541 050 13 22	<b>20 1003 50060</b> (3)
	[12] M 30 x 75				A 541 050 17 22 A 541 050 20 22	<b>20 1003 50062</b> <small>NEW</small> (4)
	(3) Rollenstößel/roller tappet/poussoir à galet/empujador de rodillos/роликовый толкатель					
	(4) Mit 2 Ölbohrungen/with 2 oil holes/avec 2 trous d'huile/con 2 agujeros de aceite/c 2-мя смазочными отверстиями					
	I [1]				A 541 050 04 33 A 541 050 06 33 A 541 050 07 33 A 541 050 08 33 A 541 050 09 33 A 541 055 07 50	<b>20 1003 50010</b> (5)
	[1]				A 541 050 05 34 A 541 050 06 34 A 541 050 07 34 A 541 050 08 34	<b>20 1003 50011</b>
	(5) IN					
	- - G - S -	- - -			A 541 010 37 21 A 541 010 50 20 A 541 010 64 20	<b>20 0803 50100</b> (6)
	- V - G - S -	- - - EVB	ready-to-install		A 541 010 37 21 A 541 010 50 20 A 541 010 64 20	<b>20 0803 50101</b> (6)
	(6) Schutzhülse/Injector sleeve/puits d'injecteur/casquillo de protección/защитная гильза Ø 9,6 mm					

M

					Reference	Item No.	
<b>513</b>		<b>130</b>					
<b>OM 521 Euro 2</b>		<b>950 - 951</b>					
40 448 6.., 40 463 6..		01.1996 →	D (LA)	6	11946 cm <sup>3</sup> 4V	260-335 kW (354-456 PS) 17,25:1 150,00 mm	
	IN [2]	45,5 x 9 x 144,9	RA/S- Cr -	- 30° -	- 5 - III	A 457 053 00 01 A 541 050 02 26	<b>160054</b>
	IN [2]	45,5 x 9 x 145,0 M + 1	S - Cr -	- 30° -	- 5 - III	A 460 053 00 01 A 541 053 01 01	<b>16204</b>
	EX [2]	17,0 x 8 x 87,0	A - -	- 45° -	- 9 -	A 541 016 05 91 A 541 016 06 91 A 541 016 07 91	<b>261101</b> (1)
	EX [2]	41,0 x 9 x 145,0	RA/S- Cr -	- 45° -	- 5 - III	A 541 050 01 27 A 541 050 02 27	<b>160055</b>
	EX [2]	42,1 x 9 x 145,0	RA/S- Cr -	- 36° -	- 5 - III	A 457 050 03 27 A 457 050 05 27	<b>16205</b>
	(1) Konstantdrosselventil - flach Exhaust brake valve - flat Soupape de réduction permanente - plate Válvula de reducción permanente - plana Постоянный дроссельный клапан						
	[50]	∅ 9 mm				A 541 053 00 26 A 541 053 01 26 A 541 053 02 26	<b>LK-2615</b>
	IN/EX [4]	15,03 x 9 x 61,0	G2			A 457 053 12 30 A 541 053 12 30 A 541 053 27 30	<b>81-16103</b> (2)
	IN/EX [4]	15,24 x 9 x 61,0	G2			A 457 053 13 30 A 541 053 13 30 A 541 053 28 30	<b>81-16104</b> (2)
	(2) abweichend zu OE Bohrung fertigbearbeitet finish-machined with other than original bore usiné à un alésage différent de l'origine orificio mecanizado de manera diferente al original в отличие от OE отверстие расточено						
	IN [2]	47,38 x 40 x 7,7	G1 30°			A 541 053 17 31 A 541 053 21 31 A 541 053 26 31	<b>92-16157</b>
	EX [2]	43,10 x 34 x 8,0	G1 45°			A 541 053 05 32	<b>92-16158</b>
	EX [1]	43,10 x 34.4 x 7,8	G1 36°			A 457 053 13 32	<b>92-16170</b> <small>NEW</small>
		613,5 mm				A 541 050 16 01 A 541 050 18 01	<b>20 1003 50101</b>
	[12]	M 30 x 75				A 541 050 17 22 A 541 050 20 22	<b>20 1003 50062</b> <small>NEW</small> (3)
	(3) Mit 2 Ölbohrungen/with 2 oil holes/avec 2 trous d'huile/con 2 agujeros de aceite/c 2-мя смазочными отверстиями						
	I [1]					A 541 050 04 33 A 541 050 06 33 A 541 050 07 33 A 541 050 08 33 A 541 050 09 33 A 541 055 07 50 A 541 050 05 34 A 541 050 06 34 A 541 050 07 34 A 541 050 08 34	<b>20 1003 50010</b> (4)
	[1]						<b>20 1003 50011</b>
	(4) IN						
Fortsetzung nächste Seite / continued on next page / suite page suivante / continuación página próxima / Продолжение на следующей странице							



					Reference	Item No.
	- - G - S -	- - -			A 541 010 37 21 A 541 010 50 20 A 541 010 64 20	<b>20 0803 50100</b> (5)
	- V - G - S -	- - - EVB	ready-to-install		A 541 010 37 21 A 541 010 50 20 A 541 010 64 20	<b>20 0803 50101</b> (5)
(5) Schutzhülse/Injector sleeve/puits d'injecteur/casquillo de protección/защитная гильза Ø 9,6 mm						

## 514 130

<b>OM 541 Euro 2/3</b>	<b>940 - 941</b> 09.1996 →	D (LA)	6	11946 cm <sup>3</sup>	4V	230-235 kW (313-320 PS)	150,00 mm
<b>OM 541 Euro 2</b>	<b>922 - 927</b> 04.1996 →	D (LA)	6	11946 cm <sup>3</sup>	4V	230-315 kW (313-428 PS)	17,25:1 150,00 mm
<b>OM 541 Euro 3</b>	<b>942 - 947, 950</b> 09.1996 →	D (LA)	6	11946 cm <sup>3</sup>	4V	260-320 kW (354-435 PS)	17,25:1 150,00 mm
<b>OM 941 Euro 2</b>	<b>920 - 921, 940</b> 01.1996 →	D (LA)	6	11946 cm <sup>3</sup>	4V	260-315 kW (354-428 PS)	17,25:1 150,00 mm

40 448 6..., 40 463 6..

	IN [2]	45,5 x 9 x 144,9	RA/S- Cr -	- 30° - -	5 - III	A 457 053 00 01 A 541 050 02 26	<b>160054</b>
	IN [2]	45,5 x 9 x 145,0	S - Cr -	- 30° - -	5 - III	A 460 053 00 01 A 541 053 01 01	<b>16204</b>
	EX [2]	17,0 x 8 x 87,0	A - -	- 45° - -	9 -	A 541 016 05 91 A 541 016 06 91 A 541 016 07 91	<b>261101</b> (1)
	EX [2]	41,0 x 9 x 145,0	RA/S- Cr -	- 45° - -	5 - III	A 541 050 01 27 A 541 050 02 27	<b>160055</b>
	EX [2]	42,1 x 9 x 145,0	RA/S- Cr -	- 36° - -	5 - III	A 457 050 03 27 A 457 050 05 27	<b>16205</b>
(1) Konstantdrosselventil - flach Exhaust brake valve - flat Soupape de réduction permanente - plate Válvula de reducción permanente - plana Постоянный дроссельный клапан							
	[50]	Ø 9 mm				A 541 053 00 26 A 541 053 01 26 A 541 053 02 26	<b>LK-2615</b>
	IN/EX [4]	15,03 x 9 x 61,0	G2			A 457 053 12 30 A 541 053 12 30 A 541 053 27 30	<b>81-16103</b> (2)
	IN/EX [4]	15,24 x 9 x 61,0	G2			A 457 053 13 30 A 541 053 13 30 A 541 053 28 30	<b>81-16104</b> (2)
(2) abweichend zu OE Bohrung fertigbearbeitet finish-machined with other than original bore usiné à un alésage différent de l'origine orificio mecanizado de manera diferente al original в отличие от OE отверстие расточено							

Fortsetzung nächste Seite / continued on next page / suite page suivante / continuación página próxima / Продолжение на следующей странице

					Reference	Item No.
IN [2]	47,38 x 40 x 7,7	G1 30°			A 541 053 17 31 A 541 053 21 31 A 541 053 26 31	<b>92-16157</b>
EX [2]	43,10 x 34 x 8,0	G1 45°			A 541 053 05 32	<b>92-16158</b>
EX [1]	43,10 x 34.4 x 7,8	G1 36°			A 457 053 13 32	<b>92-16170</b> <small>NEW</small>
	613,5 mm				A 541 050 16 01 A 541 050 18 01	<b>20 1003 50101</b>
[12]	M 30 x 75				A 541 050 03 22 A 541 050 05 22 A 541 050 07 22 A 541 050 13 22	<b>20 1003 50060</b> (3)
[12]	M 30 x 75				A 541 050 17 22 A 541 050 20 22	<b>20 1003 50062</b> <small>NEW</small> (4)
	(3) Rollenstößel/roller tappet/poussoir à galet/empujador de rodillos/роликовый толкатель					
	(4) Mit 2 Ölbohrungen/with 2 oil holes/avec 2 trous d'huile/con 2 agujeros de aceite/c 2-мя смазочными отверстиями					
I [1]					A 541 050 04 33 A 541 050 06 33 A 541 050 07 33 A 541 050 08 33 A 541 050 09 33 A 541 055 07 50	<b>20 1003 50010</b> (5)
[1]					A 541 050 05 34 A 541 050 06 34 A 541 050 07 34 A 541 050 08 34	<b>20 1003 50011</b>
(5) IN						
Fortsetzung nächste Seite / continued on next page / suite page suivante / continuación página próxima / Продолжение на следующей странице						

					Reference	Item No.
	- - G - S -	- - -			A 541 010 37 21 A 541 010 50 20 A 541 010 64 20	<b>20 0803 50100</b> (6)
	- V - G - S -	- - - EVB	ready-to-install		A 541 010 37 21 A 541 010 50 20 A 541 010 64 20	<b>20 0803 50101</b> (6)
	- - G - S -	- - -			A 541 010 19 20 A 541 010 27 20 A 541 010 34 21 A 541 010 45 20 A 541 010 53 20	<b>20 0803 50110</b> (7)
	- V - G - S -	- - - EVB	ready-to-install		A 541 010 34 21 A 541 010 53 20	<b>20 0803 50111</b> (7)
						(6) Schutzhülse/Injector sleeve/puits d'injecteur/casquillo de protección/защитная гильза Ø 9,6 mm (7) Schutzhülse/Injector sleeve/puits d'injecteur/casquillo de protección/защитная гильза Ø 7,6 mm

## 515 130

OM 541 Euro 2

928

01.1996 →

D (LA) 6 11946 cm<sup>3</sup> 4V

315 kW

(428 PS) 17,25:1 150,00 mm

40 448 6..., 40 463 6..

	IN [2]	45,5 x 9 x 144,9	RA/S- Cr -	- 30° - -	5 - III	A 457 053 00 01 A 541 050 02 26	<b>160054</b>
	IN [2]	45,5 x 9 x 145,0 M + 1	S - Cr -	- 30° - -	5 - III	A 460 053 00 01 A 541 053 01 01	<b>16204</b>
	EX [2]	17,0 x 8 x 87,0	A - -	- 45° - -	9 -	A 541 016 05 91 A 541 016 06 91 A 541 016 07 91	<b>261101</b> (1)
	EX [2]	41,0 x 9 x 145,0	RA/S- Cr -	- 45° - -	5 - III	A 541 050 01 27 A 541 050 02 27	<b>160055</b>
	EX [2]	42,1 x 9 x 145,0	RA/S- Cr -	- 36° - -	5 - III	A 457 050 03 27 A 457 050 05 27	<b>16205</b>
		(1) Konstantdrosselventil - flach Exhaust brake valve - flat Soupape de réduction permanente - plate Válvula de reducción permanente - plana Постоянный дроссельный клапан					

Fortsetzung nächste Seite / continued on next page / suite page suivante / continuación página próxima / Продолжение на следующей странице

					Reference	Item No.
[50]	Ø 9 mm				A 541 053 00 26 A 541 053 01 26 A 541 053 02 26	<b>LK-2615</b>
IN/EX [4]	15,03 x 9 x 61,0	G2			A 457 053 12 30 A 541 053 12 30 A 541 053 27 30	<b>81-16103</b> (2)
IN/EX [4]	15,24 x 9 x 61,0	G2			A 457 053 13 30 A 541 053 13 30 A 541 053 28 30	<b>81-16104</b> (2)
	(2) abweichend zu OE Bohrung fertigbearbeitet finish-machined with other than original bore usiné à un alésage différent de l'origine orificio mecanizado de manera diferente al original в отличие от OE отверстие расточено					
IN [2]	47,38 x 40 x 7,7	G1 30°			A 541 053 17 31 A 541 053 21 31 A 541 053 26 31	<b>92-16157</b>
EX [2]	43,10 x 34 x 8,0	G1 45°			A 541 053 05 32	<b>92-16158</b>
	613,5 mm				A 541 050 16 01 A 541 050 18 01	<b>20 1003 50101</b>
[12]	M 30 x 75				A 541 050 03 22 A 541 050 05 22 A 541 050 07 22 A 541 050 13 22	<b>20 1003 50060</b> (3)
[12]	M 30 x 75				A 541 050 17 22 A 541 050 20 22	<b>20 1003 50062</b> <small>NEW</small> (4)
	(3) Rollenstößel/roller tappet/poussoir à galet/empujador de rodillos/роликовый толкатель					
	(4) Mit 2 Ölbohrungen/with 2 oil holes/avec 2 trous d'huile/con 2 agujeros de aceite/c 2-мя смазочными отверстиями					
I [1]					A 541 050 04 33 A 541 050 06 33 A 541 050 07 33 A 541 050 08 33 A 541 050 09 33 A 541 055 07 50	<b>20 1003 50010</b> (5)
[1]					A 541 050 05 34 A 541 050 06 34 A 541 050 07 34 A 541 050 08 34	<b>20 1003 50011</b>
	(5) IN					

**516** **130**
**OM 941 Euro 2/3**
**900**

01.1996 →

D (LA) 6

 11946 cm<sup>3</sup> 4V

230 kW

(313 PS) 17,25:1 150,00 mm

40 448 6.., 40 463 6..

IN [2]	45,5 x 9 x 144,9	RA/S- Cr -	- 30° - -	5 - III	A 457 053 00 01 A 541 050 02 26	<b>160054</b>
IN [2]	45,5 x 9 x 145,0 M + 1	S - Cr -	- 30° - -	5 - III	A 460 053 00 01 A 541 053 01 01	<b>16204</b>
EX [2]	17,0 x 8 x 87,0	A - -	- 45° - -	9 -	A 541 016 05 91 A 541 016 06 91 A 541 016 07 91	<b>261101</b> (1)
EX [2]	41,0 x 9 x 145,0	RA/S- Cr -	- 45° - -	5 - III	A 541 050 01 27 A 541 050 02 27	<b>160055</b>
EX [2]	42,1 x 9 x 145,0	RA/S- Cr -	- 36° - -	5 - III	A 457 050 03 27 A 457 050 05 27	<b>16205</b>

Fortsetzung nächste Seite / continued on next page / suite page suivante / continuación página próxima / Продолжение на следующей странице

					Reference	Item No.
(1)	Konstantdrosselventil - flach Exhaust brake valve - flat Soupape de réduction permanente - plate Válvula de reducción permanente - plana Постоянный дроссельный клапан					
[50]	Ø 9 mm				A 541 053 00 26 A 541 053 01 26 A 541 053 02 26	<b>LK-2615</b>
IN/EX [4]	15,03 x 9 x 61,0	G2			A 457 053 12 30 A 541 053 12 30 A 541 053 27 30	<b>81-16103</b> (2)
IN/EX [4]	15,24 x 9 x 61,0	G2			A 457 053 13 30 A 541 053 13 30 A 541 053 28 30	<b>81-16104</b> (2)
(2)	abweichend zu OE Bohrung fertigbearbeitet finish-machined with other than original bore usiné à un alésage différent de l'origine orificio mecanizado de manera diferente al original в отличие от OE отверстие расточено					
IN [2]	47,38 x 40 x 7,7	G1 30°			A 541 053 17 31 A 541 053 21 31 A 541 053 26 31	<b>92-16157</b>
EX [2]	43,10 x 34 x 8,0	G1 45°			A 541 053 05 32	<b>92-16158</b>
					A 541 050 21 01	<b>20 1003 54100</b>
[12]	M 30 x 75				A 541 050 03 22 A 541 050 05 22 A 541 050 07 22 A 541 050 13 22	<b>20 1003 50060</b> (3)
(3)	Rollenstößel/roller tappet/poussoir à galet/empujador de rodillos/роликовый толкатель					
	- - G - S -	- - -			A 541 010 37 21 A 541 010 50 20 A 541 010 64 20	<b>20 0803 50100</b> (4)
	- V - G - S -	- - - EVB	ready-to-install		A 541 010 37 21 A 541 010 50 20 A 541 010 64 20	<b>20 0803 50101</b> (4)
(4)	Schutzhülse/Injector sleeve/puits d'injecteur/casquillo de protección/защитная гильза Ø 9,6 mm					

**517** **130**
**OM 941 Euro 2**
**910, 929 - 930, 960**

01.1996 →

D (LA)

6

 11946 cm<sup>3</sup> 4V

230-300 kW

(313-408 PS)

17,25:1 150,00 mm

40 448 6.., 40 463 6..

Fortsetzung nächste Seite / continued on next page / suite page suivante / continuación página próxima / Продолжение на следующей странице



					Reference	Item No.
	IN [2] 45,5 x 9 x 144,9	RA/S- Cr -	- 30° -	5 - III	A 457 053 00 01 A 541 050 02 26	<b>160054</b>
	IN [2] 45,5 x 9 x 145,0 M + 1	S - Cr -	- 30° -	5 - III	A 460 053 00 01 A 541 053 01 01	<b>16204</b>
	EX [2] 17,0 x 8 x 87,0	A - -	- 45° -	9 -	A 541 016 05 91 A 541 016 06 91 A 541 016 07 91	<b>261101</b> (1)
	EX [2] 41,0 x 9 x 145,0	RA/S- Cr -	- 45° -	5 - III	A 541 050 01 27 A 541 050 02 27	<b>160055</b>
	EX [2] 42,1 x 9 x 145,0	RA/S- Cr -	- 36° -	5 - III	A 457 050 03 27 A 457 050 05 27	<b>16205</b>
	(1) Konstantdrosselventil - flach Exhaust brake valve - flat Soupape de réduction permanente - plate Válvula de reducción permanente - plana Постоянный дроссельный клапан					
	[50] Ø 9 mm				A 541 053 00 26 A 541 053 01 26 A 541 053 02 26	<b>LK-2615</b>
	IN/EX [4] 15,03 x 9 x 61,0	G2			A 457 053 12 30 A 541 053 12 30 A 541 053 27 30	<b>81-16103</b> (2)
	IN/EX [4] 15,24 x 9 x 61,0	G2			A 457 053 13 30 A 541 053 13 30 A 541 053 28 30	<b>81-16104</b> (2)
	(2) abweichend zu OE Bohrung fertigbearbeitet finish-machined with other than original bore usiné à un alésage différent de l'origine orificio mecanizado de manera diferente al original в отличие от OE отверстие расточено					
	IN [2] 47,38 x 40 x 7,7	G1 30°			A 541 053 17 31 A 541 053 21 31 A 541 053 26 31	<b>92-16157</b>
	EX [2] 43,10 x 34 x 8,0	G1 45°			A 541 053 05 32	<b>92-16158</b>
	613,5 mm				A 541 050 16 01 A 541 050 18 01	<b>20 1003 50101</b>
	[12] M 30 x 75				A 541 050 03 22 A 541 050 05 22 A 541 050 07 22 A 541 050 13 22	<b>20 1003 50060</b> (3)
	[12] M 30 x 75				A 541 050 17 22 A 541 050 20 22	<b>20 1003 50062</b> <span style="border: 1px solid black; padding: 1px;">NEW</span> (4)
	(3) Rollenstößel/roller tappet/poussoir à galet/empujador de rodillos/роликовый толкатель					
	(4) Mit 2 Ölbohrungen/with 2 oil holes/avec 2 trous d'huile/con 2 agujeros de aceite/c 2-мя смазочными отверстиями					
	I [1]				A 541 050 04 33 A 541 050 06 33 A 541 050 07 33 A 541 050 08 33 A 541 050 09 33 A 541 055 07 50	<b>20 1003 50010</b> (5)
	[1]				A 541 050 05 34 A 541 050 06 34 A 541 050 07 34 A 541 050 08 34	<b>20 1003 50011</b>
	(5) IN					
Fortsetzung nächste Seite / continued on next page / suite page suivante / continuación página próxima / Продолжение на следующей странице						

					Reference	Item No.
	- - G - S -	- - -			A 541 010 37 21 A 541 010 50 20 A 541 010 64 20	<b>20 0803 50100</b> (6)
	- V - G - S -	- - - EVB	ready-to-install		A 541 010 37 21 A 541 010 50 20 A 541 010 64 20	<b>20 0803 50101</b> (6)
	- - G - S -	- - -			A 541 010 19 20 A 541 010 27 20 A 541 010 34 21 A 541 010 45 20 A 541 010 53 20	<b>20 0803 50110</b> (7)
	- V - G - S -	- - - EVB	ready-to-install		A 541 010 34 21 A 541 010 53 20	<b>20 0803 50111</b> (7)
						(6) Schutzhülse/Injector sleeve/puits d'injecteur/casquillo de protección/защитная гильза Ø 9,6 mm (7) Schutzhülse/Injector sleeve/puits d'injecteur/casquillo de protección/защитная гильза Ø 7,6 mm

## 518 130

OM 941 Euro 2

970, 980 - 981, 990

01.1996 →

D (LA) 6 11946 cm<sup>3</sup> 4V 260-315 kW (354-428 PS) 17,25:1 150,00 mm

40 448 6..., 40 463 6..

	IN [2]	45,5 x 9 x 144,9	RA/S- Cr -	- 30° - -	5 - III	A 457 053 00 01 A 541 050 02 26	<b>160054</b>
	IN [2]	45,5 x 9 x 145,0 M + 1	S - Cr -	- 30° - -	5 - III	A 460 053 00 01 A 541 053 01 01	<b>16204</b>
	EX [2]	17,0 x 8 x 87,0	A - -	- 45° - -	9 -	A 541 016 05 91 A 541 016 06 91 A 541 016 07 91	<b>261101</b> (1)
	EX [2]	41,0 x 9 x 145,0	RA/S- Cr -	- 45° - -	5 - III	A 541 050 01 27 A 541 050 02 27	<b>160055</b>
	EX [2]	42,1 x 9 x 145,0	RA/S- Cr -	- 36° - -	5 - III	A 457 050 03 27 A 457 050 05 27	<b>16205</b>
		(1) Konstantdrosselventil - flach Exhaust brake valve - flat Soupape de réduction permanente - plate Válvula de reducción permanente - plana Постоянный дроссельный клапан					

Fortsetzung nächste Seite / continued on next page / suite page suivante / continuación página próxima / Продолжение на следующей странице

					Reference	Item No.
[50]	Ø 9 mm				A 541 053 00 26 A 541 053 01 26 A 541 053 02 26	<b>LK-2615</b>
IN/EX [4]	15,03 x 9 x 61,0	G2			A 457 053 12 30 A 541 053 12 30 A 541 053 27 30	<b>81-16103</b> (2)
IN/EX [4]	15,24 x 9 x 61,0	G2			A 457 053 13 30 A 541 053 13 30 A 541 053 28 30	<b>81-16104</b> (2)
	(2) abweichend zu OE Bohrung fertigbearbeitet finish-machined with other than original bore usiné à un alésage différent de l'origine orificio mecanizado de manera diferente al original в отличие от OE отверстие расточено					
IN [2]	47,38 x 40 x 7,7	G1 30°			A 541 053 17 31 A 541 053 21 31 A 541 053 26 31	<b>92-16157</b>
EX [2]	43,10 x 34 x 8,0	G1 45°			A 541 053 05 32	<b>92-16158</b>
EX [1]	43,10 x 34.4 x 7,8	G1 36°			A 457 053 13 32	<b>92-16170</b>
	613,5 mm				A 541 050 16 01 A 541 050 18 01 A 541 050 21 01	<b>20 1003 50101</b> <b>20 1003 54100</b>
[12]	M 30 x 75				A 541 050 03 22 A 541 050 05 22 A 541 050 07 22 A 541 050 13 22	<b>20 1003 50060</b> (3)
[12]	M 30 x 75				A 541 050 17 22 A 541 050 20 22	<b>20 1003 50062</b> (4)
	(3) Rollenstößel/roller tappet/poussoir à galet/empujador de rodillos/роликовый толкатель					
	(4) Mit 2 Ölbohrungen/with 2 oil holes/avec 2 trous d'huile/con 2 agujeros de aceite/c 2-мя смазочными отверстиями					
I [1]					A 541 050 04 33 A 541 050 06 33 A 541 050 07 33 A 541 050 08 33 A 541 050 09 33 A 541 055 07 50	<b>20 1003 50010</b> (5)
[1]					A 541 050 05 34 A 541 050 06 34 A 541 050 07 34 A 541 050 08 34	<b>20 1003 50011</b>
(5) IN						
Fortsetzung nächste Seite / continued on next page / suite page suivante / continuación página próxima / Продолжение на следующей странице						

M

					Reference	Item No.
	- - G - S -	- - -			A 541 010 37 21 A 541 010 50 20 A 541 010 64 20	<b>20 0803 50100</b> (6)
	- V - G - S -	- - - EVB	ready-to-install		A 541 010 37 21 A 541 010 50 20 A 541 010 64 20	<b>20 0803 50101</b> (6)
	- - G - S -	- - -			A 541 010 19 20 A 541 010 27 20 A 541 010 34 21 A 541 010 45 20 A 541 010 53 20	<b>20 0803 50110</b> (7)
	- V - G - S -	- - - EVB	ready-to-install		A 541 010 34 21 A 541 010 53 20	<b>20 0803 50111</b> (7)
						(6) Schutzhülse/Injector sleeve/puits d'injecteur/casquillo de protección/защитная гильза Ø 9,6 mm (7) Schutzhülse/Injector sleeve/puits d'injecteur/casquillo de protección/защитная гильза Ø 7,6 mm

## 519 130

<b>OM 542 Euro 2</b>	<b>923</b> 04.1997 →	D (LA)	8	15928 cm <sup>3</sup>	4V	420 kW	(571 PS)	17,25:1	150,00 mm
<b>OM 542 Euro 3</b>	<b>940 - 945, 948</b> 02.1996 →	D (LA)	8	15928 cm <sup>3</sup>	4V	320-425 kW	(435-578 PS)		150,00 mm
<b>OM 942 Euro 2</b>	<b>925, 990</b> 06.1996 →	D (LA)	8	15928 cm <sup>3</sup>	4V	330-448 kW	(544-609 PS)	17,25:1	150,00 mm

40 448 6..., 40 463 6..

	IN [2]	45,5 x 9 x 144,9	RA/S- Cr -	- 30° -	-	5 - III	A 457 053 00 01 A 541 050 02 26	<b>160054</b>
	IN [2]	45,5 x 9 x 145,0 M + 1	S - Cr -	- 30° -	-	5 - III	A 460 053 00 01 A 541 053 01 01	<b>16204</b>
	EX [2]	17,0 x 8 x 87,0	A - -	- 45° -	-	9 -	A 541 016 05 91 A 541 016 06 91 A 541 016 07 91	<b>261101</b> (1)
	EX [2]	41,0 x 9 x 145,0	RA/S- Cr -	- 45° -	-	5 - III	A 541 050 01 27 A 541 050 02 27	<b>160055</b>
	EX [2]	42,1 x 9 x 145,0	RA/S- Cr -	- 36° -	-	5 - III	A 457 050 03 27 A 457 050 05 27	<b>16205</b>

Fortsetzung nächste Seite / continued on next page / suite page suivante / continuación página próxima / Продолжение на следующей странице

					Reference	Item No.
	(1) Konstantdrosselventil - flach Exhaust brake valve - flat Soupape de réduction permanente - plate Válvula de reducción permanente - plana Постоянный дроссельный клапан					
[50]	Ø 9 mm				A 541 053 00 26 A 541 053 01 26 A 541 053 02 26	<b>LK-2615</b>
IN/EX [4]	15,03 x 9 x 61,0	G2			A 457 053 12 30 A 541 053 12 30 A 541 053 27 30	<b>81-16103</b> (2)
IN/EX [4]	15,24 x 9 x 61,0	G2			A 457 053 13 30 A 541 053 13 30 A 541 053 28 30	<b>81-16104</b> (2)
	(2) abweichend zu OE Bohrung fertigbearbeitet finish-machined with other than original bore usiné à un alésage différent de l'origine orificio mecanizado de manera diferente al original в отличие от OE отверстие расточено					
IN [2]	47,38 x 40 x 7,7	G1 30°			A 541 053 17 31 A 541 053 21 31 A 541 053 26 31	<b>92-16157</b>
EX [2]	43,10 x 34 x 8,0	G1 45°			A 541 053 05 32	<b>92-16158</b>
EX [1]	43,10 x 34.4 x 7,8	G1 36°			A 457 053 13 32	<b>92-16170</b> <small>NEW</small>
	779,5 mm - 8,3 mm				A 542 050 14 01	<b>20 1003 50201</b>
[12]	M 30 x 75				A 541 050 03 22 A 541 050 05 22 A 541 050 07 22 A 541 050 13 22	<b>20 1003 50060</b> (3)
[12]	M 30 x 75				A 541 050 17 22 A 541 050 20 22	<b>20 1003 50062</b> <small>NEW</small> (4)
	(3) Rollenstößel/roller tappet/poussoir à galet/empujador de rodillos/роликовый толкатель					
	(4) Mit 2 Ölbohrungen/with 2 oil holes/avec 2 trous d'huile/con 2 agujeros de aceite/c 2-мя смазочными отверстиями					
I [1]					A 541 050 04 33 A 541 050 06 33 A 541 050 07 33 A 541 050 08 33 A 541 050 09 33 A 541 055 07 50	<b>20 1003 50010</b> (5)
[1]					A 541 050 05 34 A 541 050 06 34 A 541 050 07 34 A 541 050 08 34	<b>20 1003 50011</b>
	(5) IN					
Fortsetzung nächste Seite / continued on next page / suite page suivante / continuación página próxima / Продолжение на следующей странице						

M



					Reference	Item No.
	- - G - S -	- - -			A 541 010 37 21 A 541 010 50 20 A 541 010 64 20	<b>20 0803 50100</b> (6)
	- V - G - S -	- - - EVB	ready-to-install		A 541 010 37 21 A 541 010 50 20 A 541 010 64 20	<b>20 0803 50101</b> (6)
	- - G - S -	- - -			A 541 010 19 20 A 541 010 27 20 A 541 010 34 21 A 541 010 45 20 A 541 010 53 20	<b>20 0803 50110</b> (7)
	- V - G - S -	- - - EVB	ready-to-install		A 541 010 34 21 A 541 010 53 20	<b>20 0803 50111</b> (7)
						(6) Schutzhülse/Injector sleeve/puits d'injecteur/casquillo de protección/защитная гильза Ø 9,6 mm (7) Schutzhülse/Injector sleeve/puits d'injecteur/casquillo de protección/защитная гильза Ø 7,6 mm

## 520 130

OM 522 Euro 2

940 - 943

06.1996 →

D (LA) 8 15928 cm<sup>3</sup> 4V 362-420 kW (496-571 PS) 17,25:1 150,00 mm

40 448 6.., 40 463 6..

	IN [2]	45,5 x 9 x 144,9	RA/S- Cr -	- 30° - -	5 - III	A 457 053 00 01 A 541 050 02 26	<b>160054</b>
	IN [2]	45,5 x 9 x 145,0 M + 1	S - Cr -	- 30° - -	5 - III	A 460 053 00 01 A 541 053 01 01	<b>16204</b>
	EX [2]	17,0 x 8 x 87,0	A - -	- 45° - -	9 -	A 541 016 05 91 A 541 016 06 91 A 541 016 07 91	<b>261101</b> (1)
	EX [2]	41,0 x 9 x 145,0	RA/S- Cr -	- 45° - -	5 - III	A 541 050 01 27 A 541 050 02 27	<b>160055</b>
	EX [2]	42,1 x 9 x 145,0	RA/S- Cr -	- 36° - -	5 - III	A 457 050 03 27 A 457 050 05 27	<b>16205</b>
		(1) Konstantdrosselventil - flach Exhaust brake valve - flat Soupape de réduction permanente - plate Válvula de reducción permanente - plana Постоянный дроссельный клапан					

Fortsetzung nächste Seite / continued on next page / suite page suivante / continuación página próxima / Продолжение на следующей странице

					Reference	Item No.
[50]	Ø 9 mm				A 541 053 00 26 A 541 053 01 26 A 541 053 02 26	<b>LK-2615</b>
IN/EX [4]	15,03 x 9 x 61,0	G2			A 457 053 12 30 A 541 053 12 30 A 541 053 27 30	<b>81-16103</b> (2)
IN/EX [4]	15,24 x 9 x 61,0	G2			A 457 053 13 30 A 541 053 13 30 A 541 053 28 30	<b>81-16104</b> (2)
	(2) abweichend zu OE Bohrung fertigbearbeitet finish-machined with other than original bore usiné à un alésage différent de l'origine orificio mecanizado de manera diferente al original в отличие от OE отверстие расточено					
IN [2]	47,38 x 40 x 7,7	G1 30°			A 541 053 17 31 A 541 053 21 31 A 541 053 26 31	<b>92-16157</b>
EX [2]	43,10 x 34 x 8,0	G1 45°			A 541 053 05 32	<b>92-16158</b>
EX [1]	43,10 x 34.4 x 7,8	G1 36°			A 457 053 13 32	<b>92-16170</b>
	779,5 mm - 8,3 mm 779,5 mm - 8,3 mm				A 542 050 14 01 A 542 050 06 01	<b>20 1003 50201</b> <b>20 1003 50200</b>
[12]	M 30 x 75				A 541 050 03 22 A 541 050 05 22 A 541 050 07 22 A 541 050 13 22	<b>20 1003 50060</b> (3)
[12]	M 30 x 75				A 541 050 17 22 A 541 050 20 22	<b>20 1003 50062</b> (4)
	(3) Rollenstößel/roller tappet/poussoir à galet/empujador de rodillos/роликовый толкатель					
	(4) Mit 2 Ölbohrungen/with 2 oil holes/avec 2 trous d'huile/con 2 agujeros de aceite/c 2-мя смазочными отверстиями					
I [1]					A 541 050 04 33 A 541 050 06 33 A 541 050 07 33 A 541 050 08 33 A 541 050 09 33 A 541 055 07 50	<b>20 1003 50010</b> (5)
[1]					A 541 050 05 34 A 541 050 06 34 A 541 050 07 34 A 541 050 08 34	<b>20 1003 50011</b>
	(5) IN					
	- - G - S -	- - -			A 541 010 37 21 A 541 010 50 20 A 541 010 64 20	<b>20 0803 50100</b> (6)
	- V - G - S -	- - - EVB	ready-to-install		A 541 010 37 21 A 541 010 50 20 A 541 010 64 20	<b>20 0803 50101</b> (6)

Fortsetzung nächste Seite / continued on next page / suite page suivante / continuación página próxima / Продолжение на следующей странице

					Reference	Item No.
(6) Schutzhülse/Injector sleeve/puits d'injecteur/casquillo de protección/защитная гильза Ø 9,6 mm						
<b>521</b>		<b>130</b>				
<b>OM 942 Euro 2</b>						
<b>900, 910 - 912, 930, 960, 970, 980</b>						
06.1996 → D (LA) 8 15928 cm <sup>3</sup> 4V 350-420 kW (470-570 PS) 17,25:1 150,00 mm						
40 448 6..., 40 463 6...						
	IN [2]	45,5 x 9 x 144,9	RA/S- Cr -	- 30° - -	5 - III	A 457 053 00 01 A 541 050 02 26 <b>160054</b>
	IN [2]	45,5 x 9 x 145,0 M + 1	S - Cr -	- 30° - -	5 - III	A 460 053 00 01 A 541 053 01 01 <b>16204</b>
	EX [2]	17,0 x 8 x 87,0	A - -	- 45° - -	9 -	A 541 016 05 91 A 541 016 06 91 A 541 016 07 91 <b>261101</b> (1)
	EX [2]	41,0 x 9 x 145,0	RA/S- Cr -	- 45° - -	5 - III	A 541 050 01 27 A 541 050 02 27 <b>160055</b>
	EX [2]	42,1 x 9 x 145,0	RA/S- Cr -	- 36° - -	5 - III	A 457 050 03 27 A 457 050 05 27 <b>16205</b>
	(1) Konstantdrosselventil - flach Exhaust brake valve - flat Soupape de réduction permanente - plate Válvula de reducción permanente - plana Постоянный дроссельный клапан					
	[50]	Ø 9 mm				A 541 053 00 26 A 541 053 01 26 A 541 053 02 26 <b>LK-2615</b>
	IN/EX [4]	15,03 x 9 x 61,0	G2			A 457 053 12 30 A 541 053 12 30 A 541 053 27 30 <b>81-16103</b> (2)
	IN/EX [4]	15,24 x 9 x 61,0	G2			A 457 053 13 30 A 541 053 13 30 A 541 053 28 30 <b>81-16104</b> (2)
	(2) abweichend zu OE Bohrung fertigbearbeitet finish-machined with other than original bore usiné à un alésage différent de l'origine orificio mecanizado de manera diferente al original в отличие от OE отверстие расточено					
	IN [2]	47,38 x 40 x 7,7	G1 30°			A 541 053 17 31 A 541 053 21 31 A 541 053 26 31 <b>92-16157</b>
	EX [2]	43,10 x 34 x 8,0	G1 45°			A 541 053 05 32 <b>92-16158</b>
		779,5 mm - 8,3 mm				A 542 050 14 01 <b>20 1003 50201</b>
	[12]	M 30 x 75				A 541 050 03 22 A 541 050 05 22 A 541 050 07 22 A 541 050 13 22 <b>20 1003 50060</b> (3)
	[12]	M 30 x 75				A 541 050 17 22 A 541 050 20 22 <b>20 1003 50062</b> <b>NEW</b> (4)
	(3) Rollenstößel/roller tappet/poussoir à galet/empujador de rodillos/роликовый толкатель					
	(4) Mit 2 Ölbohrungen/with 2 oil holes/avec 2 trous d'huile/con 2 agujeros de aceite/c 2-мя смазочными отверстиями					
Fortsetzung nächste Seite / continued on next page / suite page suivante / continuación página próxima / Продолжение на следующей странице						

					Reference	Item No.
I [1]					A 541 050 04 33 A 541 050 06 33 A 541 050 07 33 A 541 050 08 33 A 541 050 09 33 A 541 055 07 50	20 1003 50010 (5)
[1]					A 541 050 05 34 A 541 050 06 34 A 541 050 07 34 A 541 050 08 34	20 1003 50011
(5) IN						
	- - G - S -	- - -			A 541 010 37 21 A 541 010 50 20 A 541 010 64 20	20 0803 50100 (6)
	- V - G - S -	- - -	- EVB	ready-to-install	A 541 010 37 21 A 541 010 50 20 A 541 010 64 20	20 0803 50101 (6)
	- - G - S -	- - -			A 541 010 19 20 A 541 010 27 20 A 541 010 34 21 A 541 010 45 20 A 541 010 53 20	20 0803 50110 (7)
	- V - G - S -	- - -	- EVB	ready-to-install	A 541 010 34 21 A 541 010 53 20	20 0803 50111 (7)
						(6) Schutzhülse/Injector sleeve/puits d'injecteur/casquillo de protección/защитная гильза Ø 9,6 mm
						(7) Schutzhülse/Injector sleeve/puits d'injecteur/casquillo de protección/защитная гильза Ø 7,6 mm

**522** **130**

OM 942 Euro 2

967

06.1996 →

D (LA) 8

15928 cm<sup>3</sup> 4V

370-380 kW

(503-517 PS) 17,25:1

150,00 mm

40 448 6.., 40 463 6..









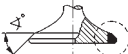

Fortsetzung nächste Seite / continued on next page / suite page suivante / continuación página próxima / Продолжение на следующей странице

					Reference	Item No.
	IN [2] 45,5 x 9 x 144,9	RA/S- Cr -	- 30° - -	5 - III	A 457 053 00 01 A 541 050 02 26	<b>160054</b>
	IN [2] 45,5 x 9 x 145,0 M + 1	S - Cr -	- 30° - -	5 - III	A 460 053 00 01 A 541 053 01 01	<b>16204</b>
	EX [2] 17,0 x 8 x 87,0	A - -	- 45° - -	9 -	A 541 016 05 91 A 541 016 06 91 A 541 016 07 91	<b>261101</b> (1)
	EX [2] 41,0 x 9 x 145,0	RA/S- Cr -	- 45° - -	5 - III	A 541 050 01 27 A 541 050 02 27	<b>160055</b>
	EX [2] 42,1 x 9 x 145,0	RA/S- Cr -	- 36° - -	5 - III	A 457 050 03 27 A 457 050 05 27	<b>16205</b>
	(1) Konstantdrosselventil - flach Exhaust brake valve - flat Soupape de réduction permanente - plate Válvula de reducción permanente - plana Постоянный дроссельный клапан					
	[50] Ø 9 mm				A 541 053 00 26 A 541 053 01 26 A 541 053 02 26	<b>LK-2615</b>
	IN/EX [4] 15,03 x 9 x 61,0	G2			A 457 053 12 30 A 541 053 12 30 A 541 053 27 30	<b>81-16103</b> (2)
	IN/EX [4] 15,24 x 9 x 61,0	G2			A 457 053 13 30 A 541 053 13 30 A 541 053 28 30	<b>81-16104</b> (2)
	(2) abweichend zu OE Bohrung fertigbearbeitet finish-machined with other than original bore usiné à un alésage différent de l'origine orificio mecanizado de manera diferente al original в отличие от OE отверстие расточено					
	IN [2] 47,38 x 40 x 7,7	G1 30°			A 541 053 17 31 A 541 053 21 31 A 541 053 26 31	<b>92-16157</b>
	EX [2] 43,10 x 34 x 8,0	G1 45°			A 541 053 05 32	<b>92-16158</b>
	779,5 mm - 8,3 mm				A 542 050 14 01	<b>20 1003 50201</b>
	[12] M 30 x 75				A 541 050 03 22 A 541 050 05 22 A 541 050 07 22 A 541 050 13 22	<b>20 1003 50060</b> (3)
	[12] M 30 x 75				A 541 050 17 22 A 541 050 20 22	<b>20 1003 50062</b> <span style="border: 1px solid black; padding: 2px;">NEW</span> (4)
	(3) Rollenstößel/roller tappet/poussoir à galet/empujador de rodillos/поликовый толкатель					
	(4) Mit 2 Ölbohrungen/with 2 oil holes/avec 2 trous d'huile/con 2 agujeros de aceite/c 2-мя смазочными отверстиями					
	I [1]				A 541 050 04 33 A 541 050 06 33 A 541 050 07 33 A 541 050 08 33 A 541 050 09 33 A 541 055 07 50	<b>20 1003 50010</b> (5)
	[1]				A 541 050 05 34 A 541 050 06 34 A 541 050 07 34 A 541 050 08 34	<b>20 1003 50011</b>
	(5) IN					

M



					Reference	Item No.	
<b>523</b>		<b>130</b>	<b>OM 541 Euro 2 920 - 921</b> 09.1996 → D (LA) 6 11946 cm <sup>3</sup> 4V 230-315 kW (313-428 PS) 17,25:1 150,00 mm 40 448 6.., 40 463 6..				
	IN [2]	45,5 x 9 x 144,9	RA/S- Cr -	- 30° - -	5 - III	A 457 053 00 01 A 541 050 02 26	<b>160054</b>
	IN [2]	45,5 x 9 x 145,0 M + 1	S - Cr -	- 30° - -	5 - III	A 460 053 00 01 A 541 053 01 01	<b>16204</b>
	EX [2]	17,0 x 8 x 87,0	A - -	- 45° - -	9 -	A 541 016 05 91 A 541 016 06 91 A 541 016 07 91	<b>261101</b> (1)
	EX [2]	41,0 x 9 x 145,0	RA/S- Cr -	- 45° - -	5 - III	A 541 050 01 27 A 541 050 02 27	<b>160055</b>
	EX [2]	42,1 x 9 x 145,0	RA/S- Cr -	- 36° - -	5 - III	A 457 050 03 27 A 457 050 05 27	<b>16205</b>
	(1)	Konstantdrosselventil - flach Exhaust brake valve - flat Soupape de réduction permanente - plate Válvula de reducción permanente - plana Постоянный дроссельный клапан					
	[50]	∅ 9 mm				A 541 053 00 26 A 541 053 01 26 A 541 053 02 26	<b>LK-2615</b>
	IN/EX [4]	15,03 x 9 x 61,0	G2			A 457 053 12 30 A 541 053 12 30 A 541 053 27 30	<b>81-16103</b> (2)
	IN/EX [4]	15,24 x 9 x 61,0	G2			A 457 053 13 30 A 541 053 13 30 A 541 053 28 30	<b>81-16104</b> (2)
	(2)	abweichend zu OE Bohrung fertigbearbeitet finish-machined with other than original bore usiné à un alésage différent de l'origine orificio mecanizado de manera diferente al original в отличие от OE отверстие расточено					
	IN [2]	47,38 x 40 x 7,7	G1 30°			A 541 053 17 31 A 541 053 21 31 A 541 053 26 31	<b>92-16157</b>
	EX [2]	43,10 x 34 x 8,0	G1 45°			A 541 053 05 32	<b>92-16158</b>
	EX [1]	43,10 x 34.4 x 7,8	G1 36°			A 457 053 13 32	<b>92-16170</b> <span style="border: 1px solid black; padding: 2px;">NEW</span>
		613,5 mm				A 541 050 16 01 A 541 050 18 01 A 541 050 10 01	<b>20 1003 50101</b>
		613,5 mm					<b>20 1003 50100</b>
	[12]	M 30 x 75				A 541 050 03 22 A 541 050 05 22 A 541 050 07 22 A 541 050 13 22	<b>20 1003 50060</b> (3)
	[12]	M 30 x 75				A 541 050 17 22 A 541 050 20 22	<b>20 1003 50062</b> <span style="border: 1px solid black; padding: 2px;">NEW</span> (4)
	(3)	Rollenstößel/roller tappet/poussoir à galet/empujador de rodillos/роликовый толкатель					
	(4)	Mit 2 Ölbohrungen/with 2 oil holes/avec 2 trous d'huile/con 2 agujeros de aceite/c 2-мя смазочными отверстиями					
Fortsetzung nächste Seite / continued on next page / suite page suivante / continuación página próxima / Продолжение на следующей странице							

					Reference	Item No.
   [1]					A 541 050 04 33 A 541 050 06 33 A 541 050 07 33 A 541 050 08 33 A 541 050 09 33 A 541 055 07 50 A 541 050 05 34 A 541 050 06 34 A 541 050 07 34 A 541 050 08 34	<b>20 1003 50010</b> (5)  <b>20 1003 50011</b>
[1]  (5) IN						
	- - G - S -	- - -			A 541 010 37 21 A 541 010 50 20 A 541 010 64 20	<b>20 0803 50100</b> (6)
	- V - G - S -	- - -	- EVB	ready-to-install	A 541 010 37 21 A 541 010 50 20 A 541 010 64 20	<b>20 0803 50101</b> (6)
	- - G - S -	- - -			A 541 010 19 20 A 541 010 27 20 A 541 010 34 21 A 541 010 45 20 A 541 010 53 20	<b>20 0803 50110</b> (7)
	- V - G - S -	- - -	- EVB	ready-to-install	A 541 010 34 21 A 541 010 53 20	<b>20 0803 50111</b> (7)
						
						(6) Schutzhülse/Injector sleeve/puits d'injecteur/casquillo de protección/защитная гильза Ø 9,6 mm (7) Schutzhülse/Injector sleeve/puits d'injecteur/casquillo de protección/защитная гильза Ø 7,6 mm

**524**  **130**

**OM 542 Euro 2**

**920 - 921**

09.1996 →

D (LA)

8

15928 cm<sup>3</sup> 4V

350-390 kW

(476-530 PS)

17,25:1

150,00 mm

40 448 6.., 40 463 6..

Fortsetzung nächste Seite / continued on next page / suite page suivante / continuación página próxima / Продолжение на следующей странице

					Reference	Item No.
	IN [2] 45,5 x 9 x 144,9	RA/S- Cr -	- 30° -	5 - III	A 457 053 00 01 A 541 050 02 26	<b>160054</b>
	IN [2] 45,5 x 9 x 145,0 M + 1	S - Cr -	- 30° -	5 - III	A 460 053 00 01 A 541 053 01 01	<b>16204</b>
	EX [2] 17,0 x 8 x 87,0	A - -	- 45° -	9 -	A 541 016 05 91 A 541 016 06 91 A 541 016 07 91	<b>261101</b> (1)
	EX [2] 41,0 x 9 x 145,0	RA/S- Cr -	- 45° -	5 - III	A 541 050 01 27 A 541 050 02 27	<b>160055</b>
	EX [2] 42,1 x 9 x 145,0	RA/S- Cr -	- 36° -	5 - III	A 457 050 03 27 A 457 050 05 27	<b>16205</b>
	(1) Konstantdrosselventil - flach Exhaust brake valve - flat Soupape de réduction permanente - plate Válvula de reducción permanente - plana Постоянный дроссельный клапан					
	[50] Ø 9 mm				A 541 053 00 26 A 541 053 01 26 A 541 053 02 26	<b>LK-2615</b>
	IN/EX [4] 15,03 x 9 x 61,0	G2			A 457 053 12 30 A 541 053 12 30 A 541 053 27 30	<b>81-16103</b> (2)
	IN/EX [4] 15,24 x 9 x 61,0	G2			A 457 053 13 30 A 541 053 13 30 A 541 053 28 30	<b>81-16104</b> (2)
	(2) abweichend zu OE Bohrung fertigbearbeitet finish-machined with other than original bore usiné à un alésage différent de l'origine orificio mecanizado de manera diferente al original в отличие от OE отверстие расточено					
	IN [2] 47,38 x 40 x 7,7	G1 30°			A 541 053 17 31 A 541 053 21 31 A 541 053 26 31	<b>92-16157</b>
	EX [2] 43,10 x 34 x 8,0	G1 45°			A 541 053 05 32	<b>92-16158</b>
	EX [1] 43,10 x 34.4 x 7,8	G1 36°			A 457 053 13 32	<b>92-16170</b> <small>NEW</small>
	779,5 mm - 8,3 mm 779,5 mm - 8,3 mm				A 542 050 14 01 A 542 050 06 01	<b>20 1003 50201</b> <b>20 1003 50200</b>
	[12] M 30 x 75				A 541 050 03 22 A 541 050 05 22 A 541 050 07 22 A 541 050 13 22	<b>20 1003 50060</b> (3)
	[12] M 30 x 75				A 541 050 17 22 A 541 050 20 22	<b>20 1003 50062</b> <small>NEW</small> (4)
	(3) Rollenstößel/roller tappet/poussoir à galet/empujador de rodillos/роликовый толкатель					
	(4) Mit 2 Ölbohrungen/with 2 oil holes/avec 2 trous d'huile/con 2 agujeros de aceite/c 2-мя смазочными отверстиями					
	I [1]				A 541 050 04 33 A 541 050 06 33 A 541 050 07 33 A 541 050 08 33 A 541 050 09 33 A 541 055 07 50 A 541 050 05 34 A 541 050 06 34 A 541 050 07 34 A 541 050 08 34	<b>20 1003 50010</b> (5)
	[1]					<b>20 1003 50011</b>
	(5) IN					
Fortsetzung nächste Seite / continued on next page / suite page suivante / continuación página próxima / Продолжение на следующей странице						

M

					Reference	Item No.
	- - G - S -	- - -			A 541 010 37 21 A 541 010 50 20 A 541 010 64 20	<b>20 0803 50100</b> (6)
	- - G - S -	- - -			A 541 010 19 20 A 541 010 27 20 A 541 010 34 21 A 541 010 45 20 A 541 010 53 20	<b>20 0803 50110</b> (7)
	- V - G - S -	- - -	- EVB	ready-to-install	A 541 010 34 21 A 541 010 53 20	<b>20 0803 50111</b> (7)
						(6) Schutzhülse/Injector sleeve/puits d'injecteur/casquillo de protección/защитная гильза Ø 9,6 mm (7) Schutzhülse/Injector sleeve/puits d'injecteur/casquillo de protección/защитная гильза Ø 7,6 mm

M

**525** **130**

**OM 542 Euro 2**      **925 - 926**  
09.1996 →      D (LA) 8 15928 cm<sup>3</sup> 4V 350-390 kW (476-530 PS) 17,25:1 150,00 mm  
40 448 6..., 40 463 6..

	IN [2]	45,5 x 9 x 144,9	RA/S- Cr -	- 30° - -	5 - III	A 457 053 00 01 A 541 050 02 26	<b>160054</b>
	IN [2]	45,5 x 9 x 145,0 M + 1	S - Cr -	- 30° - -	5 - III	A 460 053 00 01 A 541 053 01 01	<b>16204</b>
	EX [2]	17,0 x 8 x 87,0	A - -	- 45° - -	9 -	A 541 016 05 91 A 541 016 06 91 A 541 016 07 91	<b>261101</b> (1)
	EX [2]	41,0 x 9 x 145,0	RA/S- Cr -	- 45° - -	5 - III	A 541 050 01 27 A 541 050 02 27	<b>160055</b>
	EX [2]	42,1 x 9 x 145,0	RA/S- Cr -	- 36° - -	5 - III	A 457 050 03 27 A 457 050 05 27	<b>16205</b>
	(1)	Konstantdrosselventil - flach Exhaust brake valve - flat Soupape de réduction permanente - plate Válvula de reducción permanente - plana Постоянный дроссельный клапан					
	[50]	Ø 9 mm				A 541 053 00 26 A 541 053 01 26 A 541 053 02 26	<b>LK-2615</b>
	IN/EX [4]	15,03 x 9 x 61,0	G2			A 457 053 12 30 A 541 053 12 30 A 541 053 27 30	<b>81-16103</b> (2)
	IN/EX [4]	15,24 x 9 x 61,0	G2			A 457 053 13 30 A 541 053 13 30 A 541 053 28 30	<b>81-16104</b> (2)

Fortsetzung nächste Seite / continued on next page / suite page suivante / continuación página próxima / Продолжение на следующей странице

					Reference	Item No.
	(2) abweichend zu OE Bohrung fertigbearbeitet finish-machined with other than original bore usiné à un alésage différent de l'origine orificio mecanizado de manera diferente al original в отличие от OE отверстие расточено					
	IN [2] 47,38 x 40 x 7,7	G1 30°			A 541 053 17 31 A 541 053 21 31 A 541 053 26 31	<b>92-16157</b>
	EX [2] 43,10 x 34 x 8,0	G1 45°			A 541 053 05 32	<b>92-16158</b>
	EX [1] 43,10 x 34.4 x 7,8	G1 36°			A 457 053 13 32	<b>92-16170</b> <small>NEW</small>
	779,5 mm - 8,3 mm 779,5 mm - 8,3 mm				A 542 050 14 01 A 542 050 06 01	<b>20 1003 50201</b> <b>20 1003 50200</b>
	[12] M 30 x 75				A 541 050 03 22 A 541 050 05 22 A 541 050 07 22 A 541 050 13 22	<b>20 1003 50060</b> (3)
	[12] M 30 x 75				A 541 050 17 22 A 541 050 20 22	<b>20 1003 50062</b> <small>NEW</small> (4)
	(3) Rollenstößel/roller tappet/poussoir à galet/empujador de rodillos/роликовый толкатель					
	(4) Mit 2 Ölbohrungen/with 2 oil holes/avec 2 trous d'huile/con 2 agujeros de aceite/c 2-мя смазочными отверстиями					
	I [1]				A 541 050 04 33 A 541 050 06 33 A 541 050 07 33 A 541 050 08 33 A 541 050 09 33 A 541 055 07 50	<b>20 1003 50010</b> (5)
	[1]				A 541 050 05 34 A 541 050 06 34 A 541 050 07 34 A 541 050 08 34	<b>20 1003 50011</b>
	(5) IN					
Fortsetzung nächste Seite / continued on next page / suite page suivante / continuación página próxima / Продолжение на следующей странице						



					Reference	Item No.
	- - G - S -	- - -			A 541 010 37 21 A 541 010 50 20 A 541 010 64 20	<b>20 0803 50100</b> (6)
	- V - G - S -	- - - EVB	ready-to-install		A 541 010 37 21 A 541 010 50 20 A 541 010 64 20	<b>20 0803 50101</b> (6)
	- - G - S -	- - -			A 541 010 19 20 A 541 010 27 20 A 541 010 34 21 A 541 010 45 20 A 541 010 53 20	<b>20 0803 50110</b> (7)
	- V - G - S -	- - - EVB	ready-to-install		A 541 010 34 21 A 541 010 53 20	<b>20 0803 50111</b> (7)
						(6) Schutzhülse/Injector sleeve/puits d'injecteur/casquillo de protección/защитная гильза Ø 9,6 mm (7) Schutzhülse/Injector sleeve/puits d'injecteur/casquillo de protección/защитная гильза Ø 7,6 mm

## 526 130

OM 542 Euro 2

922

04.1997 → 10.2002 D (LA) 8 15928 cm<sup>3</sup> 4V 420 kW (571 PS) 17,25:1 150,00 mm

40 448 6..., 40 463 6..

	IN [2]	45,5 x 9 x 144,9	RA/S- Cr -	- 30° - -	5 - III	A 457 053 00 01 A 541 050 02 26	<b>160054</b>
	IN [2]	45,5 x 9 x 145,0 M + 1	S - Cr -	- 30° - -	5 - III	A 460 053 00 01 A 541 053 01 01	<b>16204</b>
	EX [2]	17,0 x 8 x 87,0	A - -	- 45° - -	9 -	A 541 016 05 91 A 541 016 06 91 A 541 016 07 91	<b>261101</b> (1)
	EX [2]	41,0 x 9 x 145,0	RA/S- Cr -	- 45° - -	5 - III	A 541 050 01 27 A 541 050 02 27	<b>160055</b>
	EX [2]	42,1 x 9 x 145,0	RA/S- Cr -	- 36° - -	5 - III	A 457 050 03 27 A 457 050 05 27	<b>16205</b>
		(1) Konstantdrosselventil - flach Exhaust brake valve - flat Soupape de réduction permanente - plate Válvula de reducción permanente - plana Постоянный дроссельный клапан					

Fortsetzung nächste Seite / continued on next page / suite page suivante / continuación página próxima / Продолжение на следующей странице

					Reference	Item No.
[50]	Ø 9 mm				A 541 053 00 26 A 541 053 01 26 A 541 053 02 26	<b>LK-2615</b>
IN/EX [4]	15,03 x 9 x 61,0	G2			A 457 053 12 30 A 541 053 12 30 A 541 053 27 30	<b>81-16103</b> (2)
IN/EX [4]	15,24 x 9 x 61,0	G2			A 457 053 13 30 A 541 053 13 30 A 541 053 28 30	<b>81-16104</b> (2)
	(2) abweichend zu OE Bohrung fertigbearbeitet finish-machined with other than original bore usiné à un alésage différent de l'origine orificio mecanizado de manera diferente al original в отличие от OE отверстия расточено					
IN [2]	47,38 x 40 x 7,7	G1 30°			A 541 053 17 31 A 541 053 21 31 A 541 053 26 31	<b>92-16157</b>
EX [2]	43,10 x 34 x 8,0	G1 45°			A 541 053 05 32	<b>92-16158</b>
EX [1]	43,10 x 34.4 x 7,8	G1 36°			A 457 053 13 32	<b>92-16170</b> <small>NEW</small>
	779,5 mm - 8,3 mm				A 542 050 14 01	<b>20 1003 50201</b>
[12]	M 30 x 75				A 541 050 03 22 A 541 050 05 22 A 541 050 07 22 A 541 050 13 22	<b>20 1003 50060</b> (3)
[12]	M 30 x 75				A 541 050 17 22 A 541 050 20 22	<b>20 1003 50062</b> <small>NEW</small> (4)
	(3) Rollenstößel/roller tappet/poussoir à galet/empujador de rodillos/роликовый толкатель					
	(4) Mit 2 Ölbohrungen/with 2 oil holes/avec 2 trous d'huile/con 2 agujeros de aceite/c 2-мя смазочными отверстиями					
I [1]					A 541 050 04 33 A 541 050 06 33 A 541 050 07 33 A 541 050 08 33 A 541 050 09 33 A 541 055 07 50	<b>20 1003 50010</b> (5)
[1]					A 541 050 05 34 A 541 050 06 34 A 541 050 07 34 A 541 050 08 34	<b>20 1003 50011</b>
(5) IN						

Fortsetzung nächste Seite / continued on next page / suite page suivante / continuación página próxima / Продолжение на следующей странице

M

					Reference	Item No.
	- - G - S -	- - -			A 541 010 37 21 A 541 010 50 20 A 541 010 64 20	<b>20 0803 50100</b> (6)
	- - G - S -	- - -			A 541 010 19 20 A 541 010 27 20 A 541 010 34 21 A 541 010 45 20 A 541 010 53 20	<b>20 0803 50110</b> (7)
	- V - G - S -	- - -	- EVB	ready-to-install	A 541 010 34 21 A 541 010 53 20	<b>20 0803 50111</b> (7)
<p>(6) Schutzhülse/Injector sleeve/puits d'injecteur/casquillo de protección/защитная гильза Ø 9,6 mm</p> <p>(7) Schutzhülse/Injector sleeve/puits d'injecteur/casquillo de protección/защитная гильза Ø 7,6 mm</p>						

M

**527** **130**

**OM 542 Euro 2**

**924**

04.1997 →

D

(LA)

8

15928 cm<sup>3</sup> 4V

420 kW

(571 PS) 17,25:1 150,00 mm

40 448 6..., 40 463 6..

	IN [2]	45,5 x 9 x 144,9	RA/S- Cr -	- 30° - -	5 - III	A 457 053 00 01 A 541 050 02 26	<b>160054</b>
	IN [2]	45,5 x 9 x 145,0 M + 1	S - Cr -	- 30° - -	5 - III	A 460 053 00 01 A 541 053 01 01	<b>16204</b>
	EX [2]	17,0 x 8 x 87,0	A - -	- 45° - -	9 -	A 541 016 05 91 A 541 016 06 91 A 541 016 07 91	<b>261101</b> (1)
	EX [2]	41,0 x 9 x 145,0	RA/S- Cr -	- 45° - -	5 - III	A 541 050 01 27 A 541 050 02 27	<b>160055</b>
	EX [2]	42,1 x 9 x 145,0	RA/S- Cr -	- 36° - -	5 - III	A 457 050 03 27 A 457 050 05 27	<b>16205</b>
<p>(1) Konstantdrosselventil - flach Exhaust brake valve - flat Soupape de réduction permanente - plate Válvula de reducción permanente - plana Постоянный дроссельный клапан</p>							
	[50]	Ø 9 mm				A 541 053 00 26 A 541 053 01 26 A 541 053 02 26	<b>LK-2615</b>
	IN/EX [4]	15,03 x 9 x 61,0	G2			A 457 053 12 30 A 541 053 12 30 A 541 053 27 30	<b>81-16103</b> (2)
	IN/EX [4]	15,24 x 9 x 61,0	G2			A 457 053 13 30 A 541 053 13 30 A 541 053 28 30	<b>81-16104</b> (2)

Fortsetzung nächste Seite / continued on next page / suite page suivante / continuación página próxima / Продолжение на следующей странице

					Reference	Item No.
	(2) abweichend zu OE Bohrung fertigbearbeitet finish-machined with other than original bore usiné à un alésage différent de l'origine orificio mecanizado de manera diferente al original в отличие от OE отверстие расточено					
	IN [2] 47,38 x 40 x 7,7	G1 30°			A 541 053 17 31 A 541 053 21 31 A 541 053 26 31	<b>92-16157</b>
	EX [2] 43,10 x 34 x 8,0	G1 45°			A 541 053 05 32	<b>92-16158</b>
	779,5 mm - 8,3 mm 779,5 mm - 8,3 mm				A 542 050 14 01 A 542 050 06 01	<b>20 1003 50201</b> <b>20 1003 50200</b>
	[12] M 30 x 75				A 541 050 03 22 A 541 050 05 22 A 541 050 07 22 A 541 050 13 22	<b>20 1003 50060</b> (3)
	[12] M 30 x 75				A 541 050 17 22 A 541 050 20 22	<b>20 1003 50062</b> <small>NEW</small> (4)
	(3) Rollenstößel/roller tappet/poussoir à galet/empujador de rodillos/роликовый толкатель					
	(4) Mit 2 Ölbohrungen/with 2 oil holes/avec 2 trous d'huile/con 2 agujeros de aceite/c 2-мя смазочными отверстиями					
	I [1]				A 541 050 04 33 A 541 050 06 33 A 541 050 07 33 A 541 050 08 33 A 541 050 09 33 A 541 055 07 50	<b>20 1003 50010</b> (5)
	[1]				A 541 050 05 34 A 541 050 06 34 A 541 050 07 34 A 541 050 08 34	<b>20 1003 50011</b>
	(5) IN					

**528**
**130**

<b>OM 542 Euro 5</b>	<b>963, 966, 971</b>	08.1998 →	D (LA)	8	15928 cm <sup>3</sup>	4V	350-448 kW	(476-609 PS)	150,00 mm
<b>OM 542 Euro 4/5</b>	<b>965</b>	04.2003 →	D (LA)	8	15928 cm <sup>3</sup>	4V	440 kW	(598 PS) 18,5:1	150,00 mm

40 310 6..

	IN [2] 45,5 x 9 x 144,9	RA/S- Cr -	- 30° -	-	5 - III	A 457 053 00 01 A 541 050 02 26	<b>160054</b>
	IN [2] 45,5 x 9 x 145,0 M + 1	S - Cr -	- 30° -	-	5 - III	A 460 053 00 01 A 541 053 01 01	<b>16204</b>
	EX [2] 17,0 x 8 x 87,0	A - -	- 45° -	-	9 -	A 541 016 05 91 A 541 016 06 91 A 541 016 07 91	<b>261101</b> (1)
	EX [2] 41,0 x 9 x 145,0	RA/S- Cr -	- 45° -	-	5 - III	A 541 050 01 27 A 541 050 02 27	<b>160055</b>
	EX [2] 42,1 x 9 x 145,0	RA/S- Cr -	- 36° -	-	5 - III	A 457 050 03 27 A 457 050 05 27	<b>16205</b>
	(1) Konstantdrosselventil - flach Exhaust brake valve - flat Soupape de réduction permanente - plate Válvula de reducción permanente - plana Постоянный дроссельный клапан						
	[50] Ø 9 mm					A 541 053 00 26 A 541 053 01 26 A 541 053 02 26	<b>LK-2615</b>
Fortsetzung nächste Seite / continued on next page / suite page suivante / continuación página próxima / Продолжение на следующей странице							

					Reference	Item No.
	IN/EX [4] 15,03 x 9 x 61,0	G2			A 457 053 12 30 A 541 053 12 30 A 541 053 27 30	<b>81-16103</b> (2)
	IN/EX [4] 15,24 x 9 x 61,0	G2			A 457 053 13 30 A 541 053 13 30 A 541 053 28 30	<b>81-16104</b> (2)
	(2) abweichend zu OE Bohrung fertiggearbeitet finish-machined with other than original bore usiné à un alésage différent de l'origine orificio mecanizado de manera diferente al original в отличие от OE отверстие расточено					
	IN [2] 47,38 x 40 x 7,7	G1 30°			A 541 053 17 31 A 541 053 21 31 A 541 053 26 31	<b>92-16157</b>
	EX [2] 43,10 x 34 x 8,0	G1 45°			A 541 053 05 32	<b>92-16158</b>
	EX [1] 43,10 x 34,4 x 7,8	G1 36°			A 457 053 13 32	<b>92-16170</b> <small>NEW</small>
					A 542 050 17 01	<b>20 1003 54200</b>
	[12] M 30 x 75				A 541 050 17 22 A 541 050 20 22	<b>20 1003 50062</b> <small>NEW</small> (3)
	(3) Mit 2 Ölbohrungen/with 2 oil holes/avec 2 trous d'huile/con 2 agujeros de aceite/c 2-мя смазочными отверстиями					
	I [1]				A 541 050 04 33 A 541 050 06 33 A 541 050 07 33 A 541 050 08 33 A 541 050 09 33 A 541 055 07 50	<b>20 1003 50010</b> (4)
	[1]				A 541 050 05 34 A 541 050 06 34 A 541 050 07 34 A 541 050 08 34	<b>20 1003 50011</b>
	(4) IN					

**529**
**130**
**OM 542 Euro 5**
**968 - 969**

10.2002 →

D

(LA)

8

 15928 cm<sup>3</sup> 4V

480 kW

(653 PS) 18,5

150,00 mm

40 310 6..

	IN [2] 45,5 x 9 x 145,0 M + 1	S - Cr -	- 30° - -	5 - III	A 460 053 00 01 A 541 053 01 01	<b>16204</b>
	EX [2] 17,0 x 8 x 87,0	A - -	- 45° - -	9 -	A 541 016 05 91 A 541 016 06 91 A 541 016 07 91	<b>261101</b> (1)
	EX [2] 42,1 x 9 x 145,0	RA/S- Cr -	- 36° - -	5 - III	A 457 050 03 27 A 457 050 05 27	<b>16205</b>
	(1) Konstantdrosselventil - flach Exhaust brake valve - flat Soupape de réduction permanente - plate Válvula de reducción permanente - plana Постоянный дроссельный клапан					
	IN/EX [4] 15,03 x 9 x 61,0	G2			A 457 053 12 30 A 541 053 12 30 A 541 053 27 30	<b>81-16103</b> (2)
	IN/EX [4] 15,24 x 9 x 61,0	G2			A 457 053 13 30 A 541 053 13 30 A 541 053 28 30	<b>81-16104</b> (2)

Fortsetzung nächste Seite / continued on next page / suite page suivante / continuación página próxima / Продолжение на следующей странице



					Reference	Item No.
	(2)	abweichend zu OE Bohrung fertigbearbeitet finish-machined with other than original bore usiné à un alésage différent de l'origine orificio mecanizado de manera diferente al original в отличие от OE отверстие расточено				
	EX [1]	43,10 x 34.4 x 7,8	G1 36°		A 457 053 13 32	<b>92-16170</b>
	[12]	M 30 x 75			A 541 050 17 22 A 541 050 20 22	<b>20 1003 50062</b> (3)
	(3)	Mit 2 Ölbohrungen/with 2 oil holes/avec 2 trous d'huile/con 2 agujeros de aceite/c 2-мя смазочными отверстиями				
	I [1]				A 541 050 04 33 A 541 050 06 33 A 541 050 07 33 A 541 050 08 33 A 541 050 09 33 A 541 055 07 50	<b>20 1003 50010</b> (4)
	[1]				A 541 050 05 34 A 541 050 06 34 A 541 050 07 34 A 541 050 08 34	<b>20 1003 50011</b>
	(4)	IN				

**530**
**130**

<b>OM 541 Euro 5</b>	<b>996, 998</b>	04.2003 →	D (LA)	6	11946 cm <sup>3</sup>	4V	235-265 kW	(320-360 PS)	17,75:1	150,00 mm
<b>OM 541 Euro 4/5</b>	<b>953, 991, 997, 999</b>	04.2003 →	D (LA)	6	11946 cm <sup>3</sup>	4V	235-320 kW	(320-435 PS)		150,00 mm
<b>OM 941 Euro 2/3</b>	<b>991</b>		D (LA)	6	11946 cm <sup>3</sup>	4V	260-315 kW	(354-428 PS)	17,25:1	150,00 mm

40 310 6.., 41 659 6..

	IN [2]	45,5 x 9 x 145,0 M + 1	S - Cr -	- 30° - -	5 - III	A 460 053 00 01 A 541 053 01 01	<b>16204</b>
	EX [2]	42,1 x 9 x 145,0	RA/S- Cr -	- 36° - -	5 - III	A 457 050 03 27 A 457 050 05 27	<b>16205</b>
	[50]	Ø 9 mm				A 541 053 00 26 A 541 053 01 26 A 541 053 02 26	<b>LK-2615</b>
	IN/EX [4]	15,03 x 9 x 61,0	G2			A 457 053 12 30 A 541 053 12 30 A 541 053 27 30	<b>81-16103</b> (1)
	IN/EX [4]	15,24 x 9 x 61,0	G2			A 457 053 13 30 A 541 053 13 30 A 541 053 28 30	<b>81-16104</b> (1)
	(1)	abweichend zu OE Bohrung fertigbearbeitet finish-machined with other than original bore usiné à un alésage différent de l'origine orificio mecanizado de manera diferente al original в отличие от OE отверстие расточено					
	EX [1]	43,10 x 34.4 x 7,8	G1 36°			A 457 053 13 32	<b>92-16170</b>
						A 541 050 21 01	<b>20 1003 54100</b>
	[12]	M 30 x 75				A 541 050 17 22 A 541 050 20 22	<b>20 1003 50062</b> (2)
	(2)	Mit 2 Ölbohrungen/with 2 oil holes/avec 2 trous d'huile/con 2 agujeros de aceite/c 2-мя смазочными отверстиями					

Fortsetzung nächste Seite / continued on next page / suite page suivante / continuación página próxima / Продолжение на следующей странице

					Reference	Item No.
	I [1]				A 541 050 04 33 A 541 050 06 33 A 541 050 07 33 A 541 050 08 33 A 541 050 09 33 A 541 055 07 50	<b>20 1003 50010</b> (3)
	[1]				A 541 050 05 34 A 541 050 06 34 A 541 050 07 34 A 541 050 08 34	<b>20 1003 50011</b>
	(3) IN					

**531**
**130**
**OM 541 Euro 4**
**970**

04.2003 →

D

(LA)

6

 11946 cm<sup>3</sup> 4V

235 kW

(320 PS) 18,5:1 150,00 mm

40 310 6..

	IN [2]	45,5 x 9 x 144,9	RA/S- Cr -	- 30° - -	5 - III	A 457 053 00 01 A 541 050 02 26	<b>160054</b>	
	IN [2]	45,5 x 9 x 145,0 M + 1	S - Cr -	- 30° - -	5 - III	A 460 053 00 01 A 541 053 01 01	<b>16204</b>	
	EX [2]	17,0 x 8 x 87,0	A - -	- 45° - -	9 -	A 541 016 05 91 A 541 016 06 91 A 541 016 07 91	<b>261101</b> (1)	
	EX [2]	41,0 x 9 x 145,0	RA/S- Cr -	- 45° - -	5 - III	A 541 050 01 27 A 541 050 02 27	<b>160055</b>	
	EX [2]	42,1 x 9 x 145,0	RA/S- Cr -	- 36° - -	5 - III	A 457 050 03 27 A 457 050 05 27	<b>16205</b>	
	(1)	Konstantdrosselventil - flach Exhaust brake valve - flat Soupape de réduction permanente - plate Válvula de reducción permanente - plana Постоянный дроссельный клапан						
	[50]	Ø 9 mm				A 541 053 00 26 A 541 053 01 26 A 541 053 02 26	<b>LK-2615</b>	
	IN/EX [4]	15,03 x 9 x 61,0	G2			A 457 053 12 30 A 541 053 12 30 A 541 053 27 30	<b>81-16103</b> (2)	
	IN/EX [4]	15,24 x 9 x 61,0	G2			A 457 053 13 30 A 541 053 13 30 A 541 053 28 30	<b>81-16104</b> (2)	
	(2)	abweichend zu OE Bohrung fertigbearbeitet finish-machined with other than original bore usiné à un alésage différent de l'origine orificio mecanizado de manera diferente al original в отличие от OE отверстие расточено						
	IN [2]	47,38 x 40 x 7,7	G1 30°			A 541 053 17 31 A 541 053 21 31 A 541 053 26 31	<b>92-16157</b>	
	EX [2]	43,10 x 34 x 8,0	G1 45°			A 541 053 05 32	<b>92-16158</b>	
	EX [1]	43,10 x 34,4 x 7,8	G1 36°			A 457 053 13 32	<b>92-16170</b> <small>NEW</small>	
		613,5 mm				A 541 050 16 01 A 541 050 18 01 A 541 050 21 01	<b>20 1003 50101</b> <b>20 1003 54100</b>	
	[12]	M 30 x 75				A 541 050 03 22 A 541 050 05 22 A 541 050 07 22 A 541 050 13 22	<b>20 1003 50060</b> (3)	
	[12]	M 30 x 75				A 541 050 17 22 A 541 050 20 22	<b>20 1003 50062</b> <small>NEW</small> (4)	
	(3)	Rollenstößel/roller tappet/poussoir à galet/empujador de rodillos/поликовый толкатель						

Fortsetzung nächste Seite / continued on next page / suite page suivante / continuación página próxima / Продолжение на следующей странице

					Reference	Item No.
(4)	Mit 2 Ölbohrungen/with 2 oil holes/avec 2 trous d'huile/con 2 agujeros de aceite/c 2-мя смазочными отверстиями					
	I [1]				A 541 050 04 33 A 541 050 06 33 A 541 050 07 33 A 541 050 08 33 A 541 050 09 33 A 541 055 07 50 A 541 050 05 34 A 541 050 06 34 A 541 050 07 34 A 541 050 08 34	20 1003 50010 (5)  20 1003 50011
	[1]					
(5)	IN					
	- - G - S -	- - -			A 541 010 19 20 A 541 010 27 20 A 541 010 34 21 A 541 010 45 20 A 541 010 53 20	20 0803 50110 (6)
	- V - G - S -	- - - EVB	ready-to-install		A 541 010 34 21 A 541 010 53 20	20 0803 50111 (6)
(6)	Schutzhülse/Injector sleeve/puits d'injecteur/casquillo de protección/защитная гильза Ø 7,6 mm					

## 532 130

<b>OM 541 Euro 4/5</b>	<b>971</b>	04.2003 →	D (LA)	6	11946 cm <sup>3</sup>	4V	235 kW	(320 PS)	17,75:1	150,00 mm
<b>OM 541 Euro 4</b>	<b>972 - 974, 976</b>	04.2003 →	D (LA)	6	11946 cm <sup>3</sup>	4V	265-320 kW	(360-435 PS)	18,5:1	150,00 mm
<b>OM 541 Euro 3</b>	<b>978</b>	04.2003 →	D (LA)	6	11946 cm <sup>3</sup>	4V	350 kW	(476 PS)	18,5:1	150,00 mm

40 310 6..

	IN [2]	45,5 x 9 x 144,9	RA/S- Cr -	- 30° - -	5 - III	A 457 053 00 01 A 541 050 02 26	<b>160054</b>
	IN [2]	45,5 x 9 x 145,0	S - Cr -	- 30° - -	5 - III	A 460 053 00 01 A 541 053 01 01	<b>16204</b>
	EX [2]	17,0 x 8 x 87,0	A - -	- 45° - -	9 -	A 541 016 05 91 A 541 016 06 91 A 541 016 07 91	<b>261101</b> (1)
	EX [2]	41,0 x 9 x 145,0	RA/S- Cr -	- 45° - -	5 - III	A 541 050 01 27 A 541 050 02 27	<b>160055</b>
	EX [2]	42,1 x 9 x 145,0	RA/S- Cr -	- 36° - -	5 - III	A 457 050 03 27 A 457 050 05 27	<b>16205</b>
(1)	Konstantdrosselventil - flach Exhaust brake valve - flat Soupape de réduction permanente - plate Válvula de reducción permanente - plana Постоянный дроссельный клапан						

Fortsetzung nächste Seite / continued on next page / suite page suivante / continuación página próxima / Продолжение на следующей странице

					Reference	Item No.
[50]	Ø 9 mm				A 541 053 00 26 A 541 053 01 26 A 541 053 02 26	<b>LK-2615</b>
IN/EX [4]	15,03 x 9 x 61,0	G2			A 457 053 12 30 A 541 053 12 30 A 541 053 27 30	<b>81-16103</b> (2)
IN/EX [4]	15,24 x 9 x 61,0	G2			A 457 053 13 30 A 541 053 13 30 A 541 053 28 30	<b>81-16104</b> (2)
	(2) abweichend zu OE Bohrung fertiggearbeitet finish-machined with other than original bore usiné à un alésage différent de l'origine orificio mecanizado de manera diferente al original в отличие от OE отверстие расточено					
IN [2]	47,38 x 40 x 7,7	G1 30°			A 541 053 17 31 A 541 053 21 31 A 541 053 26 31	<b>92-16157</b>
EX [2]	43,10 x 34 x 8,0	G1 45°			A 541 053 05 32	<b>92-16158</b>
EX [1]	43,10 x 34.4 x 7,8	G1 36°			A 457 053 13 32	<b>92-16170</b> <span style="border: 1px solid black; padding: 1px;">NEW</span>
					A 541 050 21 01	<b>20 1003 54100</b>
[12]	M 30 x 75				A 541 050 03 22 A 541 050 05 22 A 541 050 07 22 A 541 050 13 22	<b>20 1003 50060</b> (3)
[12]	M 30 x 75				A 541 050 17 22 A 541 050 20 22	<b>20 1003 50062</b> <span style="border: 1px solid black; padding: 1px;">NEW</span> (4)
	(3) Rollenstößel/roller tappet/poussoir à galet/empujador de rodillos/роликовый толкатель					
	(4) Mit 2 Ölbohrungen/with 2 oil holes/avec 2 trous d'huile/con 2 agujeros de aceite/c 2-мя смазочными отверстиями					
I [1]					A 541 050 04 33 A 541 050 06 33 A 541 050 07 33 A 541 050 08 33 A 541 050 09 33 A 541 055 07 50	<b>20 1003 50010</b> (5)
[1]					A 541 050 05 34 A 541 050 06 34 A 541 050 07 34 A 541 050 08 34	<b>20 1003 50011</b>
	(5) IN					

## 533 130

<b>OM 541 Euro 4/5</b>	<b>979</b>	02.2005 → 12.2008	D (LA)	6	11946 cm <sup>3</sup>	4V	350 kW	(476 PS)	18,5:1	150,00 mm
<b>OM 541 Euro 4</b>	<b>975, 977</b>	04.2003 →	D (LA)	6	11946 cm <sup>3</sup>	4V	300-320 kW	(408-435 PS)	18,5:1	150,00 mm

40 310 6..

IN [2]	45,5 x 9 x 144,9	RA/S- Cr -	- 30° - -	5 - III	A 457 053 00 01 A 541 050 02 26	<b>160054</b>
IN [2]	45,5 x 9 x 145,0	S - Cr -	- 30° - -	5 - III	A 460 053 00 01 A 541 053 01 01	<b>16204</b>
EX [2]	17,0 x 8 x 87,0	A - -	- 45° - -	9 -	A 541 016 05 91 A 541 016 06 91 A 541 016 07 91	<b>261101</b> (1)
EX [2]	41,0 x 9 x 145,0	RA/S- Cr -	- 45° - -	5 - III	A 541 050 01 27 A 541 050 02 27	<b>160055</b>
EX [2]	42,1 x 9 x 145,0	RA/S- Cr -	- 36° - -	5 - III	A 457 050 03 27 A 457 050 05 27	<b>16205</b>

Fortsetzung nächste Seite / continued on next page / suite page suivante / continuación página próxima / Продолжение на следующей странице

					Reference	Item No.
(1)	Konstantdrosselventil - flach Exhaust brake valve - flat Soupape de réduction permanente - plate Válvula de reducción permanente - plana Постоянный дроссельный клапан					
[50]	Ø 9 mm				A 541 053 00 26 A 541 053 01 26 A 541 053 02 26	<b>LK-2615</b>
IN/EX [4]	15,03 x 9 x 61,0	G2			A 457 053 12 30 A 541 053 12 30 A 541 053 27 30	<b>81-16103</b> (2)
IN/EX [4]	15,24 x 9 x 61,0	G2			A 457 053 13 30 A 541 053 13 30 A 541 053 28 30	<b>81-16104</b> (2)
(2)	abweichend zu OE Bohrung fertigbearbeitet finish-machined with other than original bore usiné à un alésage différent de l'origine orificio mecanizado de manera diferente al original в отличие от OE отверстие расточено					
IN [2]	47,38 x 40 x 7,7	G1 30°			A 541 053 17 31 A 541 053 21 31 A 541 053 26 31	<b>92-16157</b>
EX [2]	43,10 x 34 x 8,0	G1 45°			A 541 053 05 32	<b>92-16158</b>
EX [1]	43,10 x 34.4 x 7,8	G1 36°			A 457 053 13 32	<b>92-16170</b> <small>NEW</small>
					A 541 050 21 01	<b>20 1003 54100</b>
[12]	M 30 x 75				A 541 050 17 22 A 541 050 20 22	<b>20 1003 50062</b> <small>NEW</small> (3)
(3)	Mit 2 Ölbohrungen/with 2 oil holes/avec 2 trous d'huile/con 2 agujeros de aceite/c 2-мя смазочными отверстиями					
I [1]					A 541 050 04 33 A 541 050 06 33 A 541 050 07 33 A 541 050 08 33 A 541 050 09 33 A 541 055 07 50	<b>20 1003 50010</b> (4)
[1]					A 541 050 05 34 A 541 050 06 34 A 541 050 07 34 A 541 050 08 34	<b>20 1003 50011</b>
(4)	IN					

**534**
**130**
**OM 541 Euro 3**
**980**

04.2003 →

 D (LA) 6 11946 cm<sup>3</sup> 4V

335 kW

(456 PS) 18,5:1 150,00 mm

40 310 6..

IN [2]	45,5 x 9 x 144,9	RA/S- Cr -	- 30° - -	5 - III	A 457 053 00 01 A 541 050 02 26	<b>160054</b>
IN [2]	45,5 x 9 x 145,0 M + 1	S - Cr -	- 30° - -	5 - III	A 460 053 00 01 A 541 053 01 01	<b>16204</b>
EX [2]	17,0 x 8 x 87,0	A - -	- 45° - -	9 -	A 541 016 05 91 A 541 016 06 91 A 541 016 07 91	<b>261101</b> (1)
EX [2]	41,0 x 9 x 145,0	RA/S- Cr -	- 45° - -	5 - III	A 541 050 01 27 A 541 050 02 27	<b>160055</b>
EX [2]	42,1 x 9 x 145,0	RA/S- Cr -	- 36° - -	5 - III	A 457 050 03 27 A 457 050 05 27	<b>16205</b>

Fortsetzung nächste Seite / continued on next page / suite page suivante / continuación página próxima / Продолжение на следующей странице

					Reference	Item No.
	(1)	Konstantdrosselventil - flach Exhaust brake valve - flat Soupape de réduction permanente - plate Válvula de reducción permanente - plana Постоянный дроссельный клапан				
	[50]	Ø 9 mm			A 541 053 00 26 A 541 053 01 26 A 541 053 02 26	<b>LK-2615</b>
	IN/EX [4]	15,03 x 9 x 61,0	G2		A 457 053 12 30 A 541 053 12 30 A 541 053 27 30	<b>81-16103</b> (2)
	IN/EX [4]	15,24 x 9 x 61,0	G2		A 457 053 13 30 A 541 053 13 30 A 541 053 28 30	<b>81-16104</b> (2)
	(2)	abweichend zu OE Bohrung fertigbearbeitet finish-machined with other than original bore usiné à un alésage différent de l'origine orificio mecanizado de manera diferente al original в отличие от OE отверстие расточено				
	IN [2]	47,38 x 40 x 7,7	G1 30°		A 541 053 17 31 A 541 053 21 31 A 541 053 26 31	<b>92-16157</b>
	EX [2]	43,10 x 34 x 8,0	G1 45°		A 541 053 05 32	<b>92-16158</b>
	EX [1]	43,10 x 34,4 x 7,8	G1 36°		A 457 053 13 32	<b>92-16170</b> <small>NEW</small>
					A 541 050 21 01	<b>20 1003 54100</b>
	[12]	M 30 x 75			A 541 050 03 22 A 541 050 05 22 A 541 050 07 22 A 541 050 13 22	<b>20 1003 50060</b> (3)
	[12]	M 30 x 75			A 541 050 17 22 A 541 050 20 22	<b>20 1003 50062</b> <small>NEW</small> (4)
	(3)	Rollenstößel/roller tappet/poussoir à galet/empujador de rodillos/роликовый толкатель				
	(4)	Mit 2 Ölbohrungen/with 2 oil holes/avec 2 trous d'huile/con 2 agujeros de aceite/c 2-мя смазочными отверстиями				
	I [1]				A 541 050 04 33 A 541 050 06 33 A 541 050 07 33 A 541 050 08 33 A 541 050 09 33 A 541 055 07 50	<b>20 1003 50010</b> (5)
	[1]				A 541 050 05 34 A 541 050 06 34 A 541 050 07 34 A 541 050 08 34	<b>20 1003 50011</b>
	(5)	IN				
Fortsetzung nächste Seite / continued on next page / suite page suivante / continuación página próxima / Продолжение на следующей странице						



					Reference	Item No.
	- - G - S -	- - - -			A 541 010 19 20 A 541 010 27 20 A 541 010 34 21 A 541 010 45 20 A 541 010 53 20	20 0803 50110 (6)
		- - - -	- - - - EVB	ready-to-install	A 541 010 34 21 A 541 010 53 20	20 0803 50111 (6)

(6) Schutzhülse/Injector sleeve/puits d'injecteur/casquillo de protección/защитная гильза Ø 7,6 mm

**535**

**130**

OM 541 Euro 3

981

04.2003 →

D (LA)

6

11946 cm<sup>3</sup> 4V

335 kW

(456 PS) 18,5:1

150,00 mm

40 310 6..

**M**

	IN [2]	45,5 x 9 x 144,9	RA/S- Cr -	- 30° - -	5 - III	A 457 053 00 01 A 541 050 02 26	160054
	IN [2]	45,5 x 9 x 145,0	S - Cr -	- 30° - -	5 - III	A 460 053 00 01 A 541 053 01 01	16204
	EX [2]	17,0 x 8 x 87,0	A - -	- 45° - -	9 -	A 541 016 05 91 A 541 016 06 91 A 541 016 07 91	261101 (1)
	EX [2]	41,0 x 9 x 145,0	RA/S- Cr -	- 45° - -	5 - III	A 541 050 01 27 A 541 050 02 27	160055
	EX [2]	42,1 x 9 x 145,0	RA/S- Cr -	- 36° - -	5 - III	A 457 050 03 27 A 457 050 05 27	16205
	(1) Konstantdrosselventil - flach Exhaust brake valve - flat Soupape de réduction permanente - plate Válvula de reducción permanente - plana Постоянный дроссельный клапан						
	[50]	Ø 9 mm				A 541 053 00 26 A 541 053 01 26 A 541 053 02 26	LK-2615
	IN/EX [4]	15,03 x 9 x 61,0	G2			A 457 053 12 30 A 541 053 12 30 A 541 053 27 30	81-16103 (2)
	IN/EX [4]	15,24 x 9 x 61,0	G2			A 457 053 13 30 A 541 053 13 30 A 541 053 28 30	81-16104 (2)
	(2) abweichend zu OE Bohrung fertigbearbeitet finish-machined with other than original bore usiné à un alésage différent de l'origine orificio mecanizado de manera diferente al original в отличие от OE отверстие расточено						
	IN [2]	47,38 x 40 x 7,7	G1 30°			A 541 053 17 31 A 541 053 21 31 A 541 053 26 31	92-16157
	EX [2]	43,10 x 34 x 8,0	G1 45°			A 541 053 05 32	92-16158
	EX [1]	43,10 x 34,4 x 7,8	G1 36°			A 457 053 13 32	92-16170 <b>NEW</b>

Fortsetzung nächste Seite / continued on next page / suite page suivante / continuación página próxima / Продолжение на следующей странице

					Reference	Item No.
	613,5 mm				A 541 050 16 01 A 541 050 18 01 A 541 050 21 01	<b>20 1003 50101</b> <b>20 1003 54100</b>
	[12] M 30 x 75				A 541 050 03 22 A 541 050 05 22 A 541 050 07 22 A 541 050 13 22	<b>20 1003 50060</b> (3)
	[12] M 30 x 75				A 541 050 17 22 A 541 050 20 22	<b>20 1003 50062</b> <b>NEW</b> (4)
	(3) Rollenstößel/roller tappet/poussoir à galet/empujador de rodillos/роликовый толкатель					
	(4) Mit 2 Ölbohrungen/with 2 oil holes/avec 2 trous d'huile/con 2 agujeros de aceite/c 2-мя смазочными отверстиями					
	I [1]				A 541 050 04 33 A 541 050 06 33 A 541 050 07 33 A 541 050 08 33 A 541 050 09 33 A 541 055 07 50	<b>20 1003 50010</b> (5)
	[1]				A 541 050 05 34 A 541 050 06 34 A 541 050 07 34 A 541 050 08 34	<b>20 1003 50011</b>
	(5) IN					

**M**
**536** **130**
**OM 541 Euro 5**
**990**

04.2003 →

D

(LA)

6

 11946 cm<sup>3</sup> 4V

300 kW

(408 PS) 17,75:1 150,00 mm

40 310 6..

	IN [2]	45,5 x 9 x 145,0 M + 1	S - Cr -	- 30° - -	5 - III	A 460 053 00 01 A 541 053 01 01	<b>16204</b>
	EX [2]	42,1 x 9 x 145,0	RA/S- Cr -	- 36° - -	5 - III	A 457 050 03 27 A 457 050 05 27	<b>16205</b>
	[50]	∅ 9 mm				A 541 053 00 26 A 541 053 01 26 A 541 053 02 26	<b>LK-2615</b>
	IN/EX [4]	15,03 x 9 x 61,0	G2			A 457 053 12 30 A 541 053 12 30 A 541 053 27 30	<b>81-16103</b> (1)
	IN/EX [4]	15,24 x 9 x 61,0	G2			A 457 053 13 30 A 541 053 13 30 A 541 053 28 30	<b>81-16104</b> (1)
	(1) abweichend zu OE Bohrung fertigbearbeitet finish-machined with other than original bore usiné à un alésage différent de l'origine orificio mecanizado de manera diferente al original в отличие от OE отверстие расточено						
	EX [1]	43,10 x 34,4 x 7,8	G1 36°			A 457 053 13 32	<b>92-16170</b> <b>NEW</b>
		613,5 mm				A 541 050 16 01 A 541 050 18 01 A 541 050 21 01	<b>20 1003 50101</b> <b>20 1003 54100</b>
	[12]	M 30 x 75				A 541 050 17 22 A 541 050 20 22	<b>20 1003 50062</b> <b>NEW</b> (2)
	(2) Mit 2 Ölbohrungen/with 2 oil holes/avec 2 trous d'huile/con 2 agujeros de aceite/c 2-мя смазочными отверстиями						

Fortsetzung nächste Seite / continued on next page / suite page suivante / continuación página próxima / Продолжение на следующей странице

					Reference	Item No.
	I [1]				A 541 050 04 33 A 541 050 06 33 A 541 050 07 33 A 541 050 08 33 A 541 050 09 33 A 541 055 07 50	20 1003 50010 (3)
	[1]				A 541 050 05 34 A 541 050 06 34 A 541 050 07 34 A 541 050 08 34	20 1003 50011
	(3) IN					

## 537 130

OM 541 Euro 4/5

993

04.2003 → D (LA) 6 11946 cm<sup>3</sup> 4V 320 kW (435 PS) 17,75:1 150,00 mm

OM 541 Euro 5

992, 994

04.2003 → D (LA) 6 11946 cm<sup>3</sup> 4V 320-335 kW (435-456 PS) 17,75:1 150,00 mm

40 310 6..

	IN [2] EX [2]	45,5 x 9 x 145,0 M + 1 42,1 x 9 x 145,0	S - Cr - RA/S- Cr -	- 30° - - - 36° - -	5 - III 5 - III	A 460 053 00 01 A 541 053 01 01 A 457 050 03 27 A 457 050 05 27	16204 16205	
	[50]	Ø 9 mm				A 541 053 00 26 A 541 053 01 26 A 541 053 02 26	LK-2615	
	IN/EX [4]	15,03 x 9 x 61,0	G2			A 457 053 12 30 A 541 053 12 30 A 541 053 27 30	81-16103 (1)	
	IN/EX [4]	15,24 x 9 x 61,0	G2			A 457 053 13 30 A 541 053 13 30 A 541 053 28 30	81-16104 (1)	
	(1)	abweichend zu OE Bohrung fertiggearbeitet finish-machined with other than original bore usiné à un alésage différent de l'origine orificio mecanizado de manera diferente al original в отличие от OE отверстия расточено						
	EX [1]	43,10 x 34.4 x 7,8	G1 36°			A 457 053 13 32	92-16170 <b>NEW</b>	
						A 541 050 21 01	20 1003 54100	
	[12]	M 30 x 75				A 541 050 17 22 A 541 050 20 22	20 1003 50062 <b>NEW</b> (2)	
	(2)	Mit 2 Ölbohrungen/with 2 oil holes/avec 2 trous d'huile/con 2 agujeros de aceite/c 2-мя смазочными отверстиями						

## 538 130

OM 541

995

04.2003 → D (LA) 6 11946 cm<sup>3</sup> 4V 335 kW (456 PS) 17,75:1 150,00 mm

40 310 6..

	EX [1]	43,10 x 34.4 x 7,8	G1 36°			A 457 053 13 32	92-16170 <b>NEW</b>	
	[12]	M 30 x 75				A 541 050 17 22 A 541 050 20 22	20 1003 50062 <b>NEW</b> (1)	
	(1)	Mit 2 Ölbohrungen/with 2 oil holes/avec 2 trous d'huile/con 2 agujeros de aceite/c 2-мя смазочными отверстиями						

					Reference	Item No.	
<b>539</b>		<b>130</b>	<b>OM 542 Euro 5</b> <b>961 - 962, 964</b> 04.2003 →    D (LA) 8 15928 cm <sup>3</sup> 4V 375-440 kW (510-598 PS) 18,5:1 150,00 mm 40 310 6..				
	IN [2]	45,5 x 9 x 144,9	RA/S- Cr -	- 30° - -	5 - III	A 457 053 00 01 A 541 050 02 26	<b>160054</b>
	IN [2]	45,5 x 9 x 145,0 M + 1	S - Cr -	- 30° - -	5 - III	A 460 053 00 01 A 541 053 01 01	<b>16204</b>
	EX [2]	17,0 x 8 x 87,0	A - -	- 45° - -	9 -	A 541 016 05 91 A 541 016 06 91 A 541 016 07 91	<b>261101</b> (1)
	EX [2]	41,0 x 9 x 145,0	RA/S- Cr -	- 45° - -	5 - III	A 541 050 01 27 A 541 050 02 27	<b>160055</b>
	EX [2]	42,1 x 9 x 145,0	RA/S- Cr -	- 36° - -	5 - III	A 457 050 03 27 A 457 050 05 27	<b>16205</b>
	(1) Konstantdrosselventil - flach Exhaust brake valve - flat Soupape de réduction permanente - plate Válvula de reducción permanente - plana Постоянный дроссельный клапан						
	[50]	Ø 9 mm				A 541 053 00 26 A 541 053 01 26 A 541 053 02 26	<b>LK-2615</b>
	IN/EX [4]	15,03 x 9 x 61,0	G2			A 457 053 12 30 A 541 053 12 30 A 541 053 27 30	<b>81-16103</b> (2)
	IN/EX [4]	15,24 x 9 x 61,0	G2			A 457 053 13 30 A 541 053 13 30 A 541 053 28 30	<b>81-16104</b> (2)
	(2) abweichend zu OE Bohrung fertigbearbeitet finish-machined with other than original bore usiné à un alésage différent de l'origine orificio mecanizado de manera diferente al original в отличие от OE отверстие расточено						
	IN [2]	47,38 x 40 x 7,7	G1 30°			A 541 053 17 31 A 541 053 21 31 A 541 053 26 31	<b>92-16157</b>
	EX [2]	43,10 x 34 x 8,0	G1 45°			A 541 053 05 32	<b>92-16158</b>
	EX [1]	43,10 x 34,4 x 7,8	G1 36°			A 457 053 13 32	<b>92-16170</b> <small>NEW</small>
						A 542 050 17 01	<b>20 1003 54200</b>
	[12]	M 30 x 75				A 541 050 03 22 A 541 050 05 22 A 541 050 07 22 A 541 050 13 22	<b>20 1003 50060</b> (3)
	[12]	M 30 x 75				A 541 050 17 22 A 541 050 20 22	<b>20 1003 50062</b> <small>NEW</small> (4)
	(3) Rollenstößel/roller tappet/poussoir à galet/empujador de rodillos/поликовый толкатель						
	(4) Mit 2 Ölbohrungen/with 2 oil holes/avec 2 trous d'huile/con 2 agujeros de aceite/c 2-мя смазочными отверстиями						
Fortsetzung nächste Seite / continued on next page / suite page suivante / continuación página próxima / Продолжение на следующей странице							

					Reference	Item No.	
	I [1]				A 541 050 04 33 A 541 050 06 33 A 541 050 07 33 A 541 050 08 33 A 541 050 09 33 A 541 055 07 50	20 1003 50010 (5)	
	[1]				A 541 050 05 34 A 541 050 06 34 A 541 050 07 34 A 541 050 08 34	20 1003 50011	
	(5) IN						
<b>540</b>		<b>130</b>					
<b>OM 542 Euro 5</b>	<b>960</b>						
40 310 6..	02.2005 →	D (LA)	8	15928 cm <sup>3</sup>	4V	375 kW (510 PS) 17,5:1 150,00 mm	
	IN [2]	45,5 x 9 x 144,9	RA/S- Cr -	- 30° - -	5 - III	A 457 053 00 01 A 541 050 02 26	160054
	IN [2]	45,5 x 9 x 145,0 M + 1	S - Cr -	- 30° - -	5 - III	A 460 053 00 01 A 541 053 01 01	16204
	EX [2]	17,0 x 8 x 87,0	A - -	- 45° - -	9 -	A 541 016 05 91 A 541 016 06 91 A 541 016 07 91	261101 (1)
	EX [2]	41,0 x 9 x 145,0	RA/S- Cr -	- 45° - -	5 - III	A 541 050 01 27 A 541 050 02 27	160055
	EX [2]	42,1 x 9 x 145,0	RA/S- Cr -	- 36° - -	5 - III	A 457 050 03 27 A 457 050 05 27	16205
	(1)	Konstantdrosselventil - flach Exhaust brake valve - flat Soupape de réduction permanente - plate Válvula de reducción permanente - plana Постоянный дроссельный клапан					
	[50]	Ø 9 mm				A 541 053 00 26 A 541 053 01 26 A 541 053 02 26	LK-2615
	IN/EX [4]	15,03 x 9 x 61,0	G2			A 457 053 12 30 A 541 053 12 30 A 541 053 27 30	81-16103 (2)
	IN/EX [4]	15,24 x 9 x 61,0	G2			A 457 053 13 30 A 541 053 13 30 A 541 053 28 30	81-16104 (2)
	(2)	abweichend zu OE Bohrung fertigbearbeitet finish-machined with other than original bore usiné à un alésage différent de l'origine orificio mecanizado de manera diferente al original в отличие от OE отверстие расточено					
	IN [2]	47,38 x 40 x 7,7	G1 30°			A 541 053 17 31 A 541 053 21 31 A 541 053 26 31	92-16157
	EX [2]	43,10 x 34 x 8,0	G1 45°			A 541 053 05 32	92-16158
	EX [1]	43,10 x 34.4 x 7,8	G1 36°			A 457 053 13 32	92-16170 <b>NEW</b>
		779,5 mm - 8,3 mm				A 542 050 14 01 A 542 050 17 01	20 1003 50201 20 1003 54200
	[12]	M 30 x 75				A 541 050 03 22 A 541 050 05 22 A 541 050 07 22 A 541 050 13 22	20 1003 50060 (3)
	[12]	M 30 x 75				A 541 050 17 22 A 541 050 20 22	20 1003 50062 <b>NEW</b> (4)
	(3)	Rollenstößel/roller tappet/poussoir à galet/empujador de rodillos/роликовый толкатель					

Fortsetzung nächste Seite / continued on next page / suite page suivante / continuación página próxima / Продолжение на следующей странице

					Reference	Item No.
(4)	Mit 2 Ölbohrungen/with 2 oil holes/avec 2 trous d'huile/con 2 agujeros de aceite/c 2-мя смазочными отверстиями					
	I [1]				A 541 050 04 33 A 541 050 06 33 A 541 050 07 33 A 541 050 08 33 A 541 050 09 33 A 541 055 07 50	<b>20 1003 50010</b> (5)
	[1]				A 541 050 05 34 A 541 050 06 34 A 541 050 07 34 A 541 050 08 34	<b>20 1003 50011</b>
	(5) IN					

**541**
**130**
**OM 440 Euro 1**
**910 - 911**

D (NA) 8 15078 cm<sup>3</sup> 2V

218 kW

(296 PS) 16,9:1 142,00 mm

90 614 6..

	IN [1]	59,0 x 12 x 142,5	A/S - Cr -	- 30° - -	5 - III	A 403 053 09 01 A 422 050 00 26 A 422 050 02 26 A 422 050 05 26 A 422 053 01 01 A 423 050 00 26 A 442 050 02 26 A 442 050 03 26	<b>16117</b>
	IN [1]	59,0 x 12 x 142,5	A/S - Cr -	- 30° - -	5 - III	A 442 050 05 26	<b>16146</b>
	EX [1]	51,0 x 12 x 142,5	A/S - Cr -	- 45° - -	5 - III	A 422 050 00 27	<b>16116</b>
	EX [1]	51,0 x 12 x 142,5	RA/S- Cr -	- 45° - -	5 - III	A 422 050 01 27 A 422 050 02 27 A 442 050 01 27 A 442 050 02 27 A 442 050 03 27 A 442 050 04 27	<b>16150</b>
	[50]	Ø 12 mm				A 422 053 00 26	<b>LK-1610</b>
	IN/EX [6]	18,03 x 12 x 67,0	G2			A 422 053 04 30	<b>81-16100</b>
	IN [2]	60,11 x 51 x 8,9	G1 30°			A 403 053 09 31 A 403 053 15 31	<b>92-16100</b>
	IN [1]	60,31 x 51 x 9,1	G1 30°			A 403 053 10 31	<b>92-16147</b>
	IN [1]	60,51 x 51 x 9,3	G1 30°			A 403 053 11 31	<b>92-16101</b>
	EX [2]	53,11 x 43 x 9,7	G1 45°			A 403 053 00 32 A 403 053 03 32 A 403 053 21 32 A 403 053 25 32 A 403 053 28 32	<b>92-16104</b>
	EX [1]	53,31 x 43 x 9,9	G1 45°			A 403 053 01 32 A 403 053 13 32 A 403 053 22 32 A 403 053 26 32 A 403 053 29 32	<b>92-16148</b>
	EX [1]	53,51 x 43 x 10,2	G1 45°			A 403 053 02 32 A 403 053 23 32 A 403 053 27 32 A 403 053 30 32	<b>92-16105</b>
		724 mm				A 422 050 01 01 A 422 050 03 01 A 422 050 05 01 A 422 050 21 01	<b>20 1003 42200</b>

Fortsetzung nächste Seite / continued on next page / suite page suivante / continuación página próxima / Продолжение на следующей странице



					Reference	Item No.
[4] [1] [1]					A 403 050 07 33 A 442 050 03 33 A 403 050 03 33 A 403 050 07 33 A 442 050 03 33 A 403 050 03 33 A 403 050 07 33 A 442 050 03 33 A 442 055 00 20	20 1002 25010 (1)  20 1003 40010  20 1003 40012 (2)
(1) nur 2-Ventiler/only 2 valves version/seulement 2 soupapes/sólo sistemas de 2 válvulas/заменяемо 2 Клапаны						
(2) mit Einstellschraube/with adjusting screw/avec vis de réglage/con tornillo de ajuste/c установочным винтом						
	- - G - S -	- - -			A 402 010 03 20 A 403 010 40 20 A 403 010 89 20 A 427 010 00 20 A 427 010 10 20 A 429 010 02 20 A 442 010 07 20	20 0803 40300
	- V - G - S -	- - -	ready-to-install		A 427 010 10 20	20 0803 40301

## 542 130

OM 521 Euro 2 952

D (LA) 6 11946 cm<sup>3</sup> 4V 430 kW (585 PS) 17,25:1 150,00 mm

OM 941 992

D (LA) 6 11946 cm<sup>3</sup> 4V 265-350 kW (360-476 PS) 17,25 150,00 mm

40 310 6..

	IN [2] EX [2]	45,5 x 9 x 145,0 M + 1 42,1 x 9 x 145,0	S - Cr - RA/S- Cr -	- 30° - - - 36° - -	5 - III 5 - III	A 460 053 00 01 A 541 053 01 01 A 457 050 03 27 A 457 050 05 27	16204 16205
	[50]	Ø 9 mm				A 541 053 00 26 A 541 053 01 26 A 541 053 02 26	LK-2615
	IN/EX [4] IN/EX [4]	15,03 x 9 x 61,0 15,24 x 9 x 61,0	G2 G2			A 457 053 12 30 A 541 053 12 30 A 541 053 27 30 A 457 053 13 30 A 541 053 13 30 A 541 053 28 30	81-16103 (1) 81-16104 (1)
	(1)	abweichend zu OE Bohrung fertigmachend finish-machined with other than original bore usiné à un alésage différent de l'origine orificio mecanizado de manera diferente al original в отличие от OE отверстие расточено					
Fortsetzung nächste Seite / continued on next page / suite page suivante / continuación página próxima / Продолжение на следующей странице							

					Reference	Item No.
IN [2]	47,38 x 40 x 7,7	G1 30°			A 541 053 17 31 A 541 053 21 31 A 541 053 26 31	<b>92-16157</b>
IN [2]	47,39 x 36.6 x 7,8	G1 30°			A 457 053 16 31	<b>92-16156</b>
EX [2]	43,10 x 34 x 8,0	G1 45°			A 541 053 05 32	<b>92-16158</b>
EX [1]	43,10 x 34.4 x 7,8	G1 36°			A 457 053 13 32	<b>92-16170</b> <small>NEW</small>
[12]	M 30 x 75				A 541 050 17 22 A 541 050 20 22	<b>20 1003 50062</b> <small>NEW</small> (2)
	(2) Mit 2 Ölbohrungen/with 2 oil holes/avec 2 trous d'huile/con 2 agujeros de aceite/c 2-мя смазочными отверстиями					

**543**
**130**
**OM 522 Euro 2**
**951 - 953**

D (LA) 8 15928 cm<sup>3</sup> 4V 530-560 kW (721-762 PS) 17,25:1 150,00 mm

IN [2]	45,5 x 9 x 144,9	RA/S- Cr -	- 30° -	- 5 - III	A 457 053 00 01 A 541 050 02 26	<b>160054</b>
IN [2]	45,5 x 9 x 145,0	S - Cr -	- 30° -	- 5 - III	A 460 053 00 01 A 541 053 01 01	<b>16204</b>
EX [2]	17,0 x 8 x 87,0	A - -	- 45° -	- 9 -	A 541 016 05 91 A 541 016 06 91 A 541 016 07 91	<b>261101</b> (1)
EX [2]	41,0 x 9 x 145,0	RA/S- Cr -	- 45° -	- 5 - III	A 541 050 01 27 A 541 050 02 27	<b>160055</b>
EX [2]	42,1 x 9 x 145,0	RA/S- Cr -	- 36° -	- 5 - III	A 457 050 03 27 A 457 050 05 27	<b>16205</b>
	(1) Konstantdrosselventil - flach Exhaust brake valve - flat Soupape de réduction permanente - plate Válvula de reducción permanente - plana Постоянный дроссельный клапан					
[50]	Ø 9 mm				A 541 053 00 26 A 541 053 01 26 A 541 053 02 26	<b>LK-2615</b>
IN/EX [4]	15,03 x 9 x 61,0	G2			A 457 053 12 30 A 541 053 12 30 A 541 053 27 30	<b>81-16103</b> (2)
IN/EX [4]	15,24 x 9 x 61,0	G2			A 457 053 13 30 A 541 053 13 30 A 541 053 28 30	<b>81-16104</b> (2)
	(2) abweichend zu OE Bohrung fertigbearbeitet finish-machined with other than original bore usiné à un alésage différent de l'origine orificio mecanizado de manera diferente al original в отличие от OE отверстие расточено					
IN [2]	47,38 x 40 x 7,7	G1 30°			A 541 053 17 31 A 541 053 21 31 A 541 053 26 31	<b>92-16157</b>
EX [2]	43,10 x 34 x 8,0	G1 45°			A 541 053 05 32	<b>92-16158</b>
EX [1]	43,10 x 34.4 x 7,8	G1 36°			A 457 053 13 32	<b>92-16170</b> <small>NEW</small>
	779,5 mm - 8,3 mm				A 542 050 14 01	<b>20 1003 50201</b>
[12]	M 30 x 75				A 541 050 17 22 A 541 050 20 22	<b>20 1003 50062</b> <small>NEW</small> (3)
	(3) Mit 2 Ölbohrungen/with 2 oil holes/avec 2 trous d'huile/con 2 agujeros de aceite/c 2-мя смазочными отверстиями					
Fortsetzung nächste Seite / continued on next page / suite page suivante / continuación página próxima / Продолжение на следующей странице						

					Reference	Item No.
I [1]					A 541 050 04 33 A 541 050 06 33 A 541 050 07 33 A 541 050 08 33 A 541 050 09 33 A 541 055 07 50	20 1003 50010 (4)
[1]					A 541 050 05 34 A 541 050 06 34 A 541 050 07 34 A 541 050 08 34	20 1003 50011
(4) IN						
	- - G - S -	- - - -			A 541 010 37 21 A 541 010 50 20 A 541 010 64 20	20 0803 50100 (5)
	- V - G - S -	- - - - EVB	ready-to-install		A 541 010 37 21 A 541 010 50 20 A 541 010 64 20	20 0803 50101 (5)
(5)	Schutzhülse/Injector sleeve/puits d'injecteur/casquillo de protección/защитная гильза Ø 9,6 mm					

**544**
**130**
**OM 522 Euro 2**
**954**
**D (LA) 8 15928 cm<sup>3</sup> 4V**
**17,25:1 150,00 mm**

40 310 6..

IN [2]	45,5 x 9 x 145,0 M + 1	S - Cr -	- 30° - -	5 - III	A 460 053 00 01 A 541 053 01 01	<b>16204</b>
EX [2]	42,1 x 9 x 145,0	RA/S- Cr -	- 36° - -	5 - III	A 457 050 03 27 A 457 050 05 27	<b>16205</b>
[50]	Ø 9 mm				A 541 053 00 26 A 541 053 01 26 A 541 053 02 26	<b>LK-2615</b>
IN/EX [4]	15,03 x 9 x 61,0	G2			A 457 053 12 30 A 541 053 12 30 A 541 053 27 30	<b>81-16103</b> (1)
IN/EX [4]	15,24 x 9 x 61,0	G2			A 457 053 13 30 A 541 053 13 30 A 541 053 28 30	<b>81-16104</b> (1)
(1)	abweichend zu OE Bohrung fertigbearbeitet finish-machined with other than original bore usiné à un alésage différent de l'origine orificio mecanizado de manera diferente al original в отличие от OE отверстие расточено					
EX [1]	43,10 x 34.4 x 7,8	G1 36°			A 457 053 13 32	<b>92-16170</b>
[12]	M 30 x 75				A 541 050 17 22 A 541 050 20 22	<b>20 1003 50062</b> (2)
Fortsetzung nächste Seite / continued on next page / suite page suivante / continuación página próxima / Продолжение на следующей странице						

					Reference	Item No.
	(2) Mit 2 Ölbohrungen/with 2 oil holes/avec 2 trous d'huile/con 2 agujeros de aceite/c 2-мя смазочными отверстиями					
	I [1]				A 541 050 04 33 A 541 050 06 33 A 541 050 07 33 A 541 050 08 33 A 541 050 09 33 A 541 055 07 50	20 1003 50010 (3)
	[1]				A 541 050 05 34 A 541 050 06 34 A 541 050 07 34 A 541 050 08 34	20 1003 50011
	(3) IN					

**545**
**130**
**OM 541 Euro 2/3 952**

D (LA) 6 11946 cm<sup>3</sup> 4V 230-260 kW (313-354 PS) 17,25:1 150,00 mm

40 448 6..., 40 463 6..

	IN [2]	45,5 x 9 x 144,9	RA/S- Cr -	- 30° - -	5 - III	A 457 053 00 01 A 541 050 02 26	<b>160054</b>
	IN [2]	45,5 x 9 x 145,0 M + 1	S - Cr -	- 30° - -	5 - III	A 460 053 00 01 A 541 053 01 01	<b>16204</b>
	EX [2]	17,0 x 8 x 87,0	A - -	- 45° - -	9 -	A 541 016 05 91 A 541 016 06 91 A 541 016 07 91	<b>261101</b> (1)
	EX [2]	41,0 x 9 x 145,0	RA/S- Cr -	- 45° - -	5 - III	A 541 050 01 27 A 541 050 02 27	<b>160055</b>
	EX [2]	42,1 x 9 x 145,0	RA/S- Cr -	- 36° - -	5 - III	A 457 050 03 27 A 457 050 05 27	<b>16205</b>
	(1) Konstantdrosselventil - flach Exhaust brake valve - flat Soupape de réduction permanente - plate Válvula de reducción permanente - plana Постоянный дроссельный клапан						
	[50]	∅ 9 mm				A 541 053 00 26 A 541 053 01 26 A 541 053 02 26	<b>LK-2615</b>
	IN/EX [4]	15,03 x 9 x 61,0	G2			A 457 053 12 30 A 541 053 12 30 A 541 053 27 30	<b>81-16103</b> (2)
	IN/EX [4]	15,24 x 9 x 61,0	G2			A 457 053 13 30 A 541 053 13 30 A 541 053 28 30	<b>81-16104</b> (2)
	(2) abweichend zu OE Bohrung fertigmachend finish-machined with other than original bore usiné à un alésage différent de l'origine orificio mecanizado de manera diferente al original в отличие от OE отверстие расточено						
	IN [2]	47,38 x 40 x 7,7	G1 30°			A 541 053 17 31 A 541 053 21 31 A 541 053 26 31	<b>92-16157</b>
	EX [2]	43,10 x 34 x 8,0	G1 45°			A 541 053 05 32	<b>92-16158</b>
	EX [1]	43,10 x 34,4 x 7,8	G1 36°			A 457 053 13 32	<b>92-16170</b> <small>NEW</small>
		613,5 mm				A 541 050 16 01 A 541 050 18 01	<b>20 1003 50101</b>

Fortsetzung nächste Seite / continued on next page / suite page suivante / continuación página próxima / Продолжение на следующей странице

					Reference	Item No.
[12]	M 30 x 75				A 541 050 03 22 A 541 050 05 22 A 541 050 07 22 A 541 050 13 22	20 1003 50060 (3)
[12]	M 30 x 75				A 541 050 17 22 A 541 050 20 22	20 1003 50062 <b>NEW</b> (4)
(3)	Rollenstößel/roller tappet/poussoir à galet/empujador de rodillos/роликовый толкатель					
(4)	Mit 2 Ölbohrungen/with 2 oil holes/avec 2 trous d'huile/con 2 agujeros de aceite/c 2-мя смазочными отверстиями					
I [1]					A 541 050 04 33 A 541 050 06 33 A 541 050 07 33 A 541 050 08 33 A 541 050 09 33 A 541 055 07 50	20 1003 50010 (5)
[1]					A 541 050 05 34 A 541 050 06 34 A 541 050 07 34 A 541 050 08 34	20 1003 50011
(5)	IN					

**546**
**130**
**OM 541 Euro 4/5 955 - 957**

D (LA) 6 11946 cm<sup>3</sup> 4V 235-300 kW (320-408 PS) 150,00 mm

IN [2]	45,5 x 9 x 145,0 M + 1	S - Cr -	- 30° - -	5 - III	A 460 053 00 01 A 541 053 01 01	16204
EX [2]	17,0 x 8 x 87,0	A - -	- 45° - -	9 -	A 541 016 05 91 A 541 016 06 91 A 541 016 07 91	261101 (1)
EX [2]	42,1 x 9 x 145,0	RA/S- Cr -	- 36° - -	5 - III	A 457 050 03 27 A 457 050 05 27	16205
(1)	Konstantdrosselventil - flach Exhaust brake valve - flat Soupape de réduction permanente - plate Válvula de reducción permanente - plana Постоянный дроссельный клапан					
IN/EX [4]	15,03 x 9 x 61,0	G2			A 457 053 12 30 A 541 053 12 30 A 541 053 27 30	81-16103 (2)
IN/EX [4]	15,24 x 9 x 61,0	G2			A 457 053 13 30 A 541 053 13 30 A 541 053 28 30	81-16104 (2)
(2)	abweichend zu OE Bohrung fertigbearbeitet finish-machined with other than original bore usiné à un alésage différent de l'origine orificio mecanizado de manera diferente al original в отличие от OE отверстие расточено					
EX [1]	43,10 x 34.4 x 7,8	G1 36°			A 457 053 13 32	92-16170 <b>NEW</b>
	613,5 mm				A 541 050 16 01 A 541 050 18 01	20 1003 50101
[12]	M 30 x 75				A 541 050 17 22 A 541 050 20 22	20 1003 50062 <b>NEW</b> (3)
(3)	Mit 2 Ölbohrungen/with 2 oil holes/avec 2 trous d'huile/con 2 agujeros de aceite/c 2-мя смазочными отверстиями					

Fortsetzung nächste Seite / continued on next page / suite page suivante / continuación página próxima / Продолжение на следующей странице

					Reference	Item No.
I [1]					A 541 050 04 33 A 541 050 06 33 A 541 050 07 33 A 541 050 08 33 A 541 050 09 33 A 541 055 07 50	20 1003 50010 (4)
[1]					A 541 050 05 34 A 541 050 06 34 A 541 050 07 34 A 541 050 08 34	20 1003 50011
(4) IN						

**547**
**130**
**OM 541 Euro 4/5 959**

D (LA) 6 11946 cm<sup>3</sup> 4V 300 kW (408 PS) 18,5:1 150,00 mm

40 310 6..

IN [2]	45,5 x 9 x 145,0 M + 1	S - Cr -	- 30° - -	5 - III	A 460 053 00 01 A 541 053 01 01	16204
EX [2]	42,1 x 9 x 145,0	RA/S- Cr -	- 36° - -	5 - III	A 457 050 03 27 A 457 050 05 27	16205
[50]	∅ 9 mm				A 541 053 00 26 A 541 053 01 26 A 541 053 02 26	LK-2615
IN/EX [4]	15,03 x 9 x 61,0	G2			A 457 053 12 30 A 541 053 12 30 A 541 053 27 30	81-16103 (1)
IN/EX [4]	15,24 x 9 x 61,0	G2			A 457 053 13 30 A 541 053 13 30 A 541 053 28 30	81-16104 (1)
	(1) abweichend zu OE Bohrung fertigbearbeitet finish-machined with other than original bore usiné à un alésage différent de l'origine orificio mecanizado de manera diferente al original в отличие от OE отверстия расточено					
IN [2]	47,38 x 40 x 7,7	G1 30°			A 541 053 17 31 A 541 053 21 31 A 541 053 26 31	92-16157
EX [2]	43,10 x 34 x 8,0	G1 45°			A 541 053 05 32	92-16158
EX [1]	43,10 x 34,4 x 7,8	G1 36°			A 457 053 13 32	92-16170 <b>NEW</b>
					A 541 050 21 01	20 1003 54100
[12]	M 30 x 75				A 541 050 17 22 A 541 050 20 22	20 1003 50062 <b>NEW</b> (2)
	(2) Mit 2 Ölbohrungen/with 2 oil holes/avec 2 trous d'huile/con 2 agujeros de aceite/c 2-мя смазочными отверстиями					
I [1]					A 541 050 04 33 A 541 050 06 33 A 541 050 07 33 A 541 050 08 33 A 541 050 09 33 A 541 055 07 50	20 1003 50010 (3)
[1]					A 541 050 05 34 A 541 050 06 34 A 541 050 07 34 A 541 050 08 34	20 1003 50011
(3) IN						



					Reference	Item No.		
<b>548</b>		<b>130</b>						
<b>OM 541 Euro 4/5 982</b>								
		D (LA)	6	11946 cm <sup>3</sup>	4V	355 kW (483 PS)	150,00 mm	
	IN [2]	45,5 x 9 x 144,9	RA/S- Cr -	- 30°	-	5 - III	A 457 053 00 01 A 541 050 02 26	<b>160054</b>
	IN [2]	45,5 x 9 x 145,0 M + 1	S - Cr -	- 30°	-	5 - III	A 460 053 00 01 A 541 053 01 01	<b>16204</b>
	EX [2]	17,0 x 8 x 87,0	A - -	- 45°	-	9 -	A 541 016 05 91 A 541 016 06 91 A 541 016 07 91	<b>261101</b> (1)
	EX [2]	41,0 x 9 x 145,0	RA/S- Cr -	- 45°	-	5 - III	A 541 050 01 27 A 541 050 02 27	<b>160055</b>
	EX [2]	42,1 x 9 x 145,0	RA/S- Cr -	- 36°	-	5 - III	A 457 050 03 27 A 457 050 05 27	<b>16205</b>
	(1) Konstantdrosselventil - flach Exhaust brake valve - flat Soupape de réduction permanente - plate Válvula de reducción permanente - plana Постоянный дроссельный клапан							
	[50]	Ø 9 mm					A 541 053 00 26 A 541 053 01 26 A 541 053 02 26	<b>LK-2615</b>
	IN/EX [4]	15,03 x 9 x 61,0	G2				A 457 053 12 30 A 541 053 12 30 A 541 053 27 30	<b>81-16103</b> (2)
	IN/EX [4]	15,24 x 9 x 61,0	G2				A 457 053 13 30 A 541 053 13 30 A 541 053 28 30	<b>81-16104</b> (2)
	(2) abweichend zu OE Bohrung fertigbearbeitet finish-machined with other than original bore usiné à un alésage différent de l'origine orificio mecanizado de manera diferente al original в отличие от OE отверстие расточено							
	IN [2]	47,38 x 40 x 7,7	G1 30°				A 541 053 17 31 A 541 053 21 31 A 541 053 26 31	<b>92-16157</b>
	EX [2]	43,10 x 34 x 8,0	G1 45°				A 541 053 05 32	<b>92-16158</b>
	EX [1]	43,10 x 34.4 x 7,8	G1 36°				A 457 053 13 32	<b>92-16170</b> <span style="border: 1px solid black; padding: 1px;">NEW</span>
		613,5 mm					A 541 050 16 01 A 541 050 18 01	<b>20 1003 50101</b>
	[12]	M 30 x 75					A 541 050 17 22 A 541 050 20 22	<b>20 1003 50062</b> <span style="border: 1px solid black; padding: 1px;">NEW</span> (3)
	(3) Mit 2 Ölbohrungen/with 2 oil holes/avec 2 trous d'huile/con 2 agujeros de aceite/c 2-мя смазочными отверстиями							
	I [1]						A 541 050 04 33 A 541 050 06 33 A 541 050 07 33 A 541 050 08 33 A 541 050 09 33 A 541 055 07 50 A 541 050 05 34 A 541 050 06 34 A 541 050 07 34 A 541 050 08 34	<b>20 1003 50010</b> (4)
	[1]							<b>20 1003 50011</b>
	(4) IN							

**M**

					Reference	Item No.
<b>549</b>	<b>130</b>					
<b>OM 542</b>	<b>976</b>	D (LA)	8	15928 cm <sup>3</sup>	4V 370-480 kW (503-653 PS) 17,25:1	150,00 mm
<b>OM 542 Euro 2/3</b>	<b>946</b>	D (LA)	8	15928 cm <sup>3</sup>	4V 370-480 kW (503-653 PS) 17,25:1	150,00 mm
	IN [2] 45,5 x 9 x 145,0 M + 1	S - Cr -	- 30° - -	5 - III	A 460 053 00 01 A 541 053 01 01	<b>16204</b>
	EX [2] 42,1 x 9 x 145,0	RA/S- Cr -	- 36° - -	5 - III	A 457 050 03 27 A 457 050 05 27	<b>16205</b>
	[50] Ø 9 mm				A 541 053 00 26 A 541 053 01 26 A 541 053 02 26	<b>LK-2615</b>
	IN/EX [4] 15,03 x 9 x 61,0	G2			A 457 053 12 30 A 541 053 12 30 A 541 053 27 30	<b>81-16103</b> (1)
	IN/EX [4] 15,24 x 9 x 61,0	G2			A 457 053 13 30 A 541 053 13 30 A 541 053 28 30	<b>81-16104</b> (1)
	(1) abweichend zu OE Bohrung fertigbearbeitet finish-machined with other than original bore usiné à un alésage différent de l'origine orificio mecanizado de manera diferente al original в отличие от OE отверстие расточено					
	IN [2] 47,38 x 40 x 7,7	G1 30°			A 541 053 17 31 A 541 053 21 31 A 541 053 26 31	<b>92-16157</b>
	IN [2] 47,39 x 36.6 x 7,8	G1 30°			A 457 053 16 31	<b>92-16156</b>
	EX [2] 43,10 x 34 x 8,0	G1 45°			A 541 053 05 32	<b>92-16158</b>
	EX [1] 43,10 x 34.4 x 7,8	G1 36°			A 457 053 13 32	<b>92-16170</b> <small>NEW</small>
	779,5 mm - 8,3 mm				A 542 050 14 01	<b>20 1003 50201</b>
	[12] M 30 x 75				A 541 050 17 22 A 541 050 20 22	<b>20 1003 50062</b> <small>NEW</small> (2)
	(2) Mit 2 Ölbohrungen/with 2 oil holes/avec 2 trous d'huile/con 2 agujeros de aceite/c 2-мя смазочными отверстиями					
<b>550</b>	<b>130</b>					
<b>OM 542 Euro 5</b>	<b>970</b>	D (LA)	8	15928 cm <sup>3</sup>	4V 448 kW (609 PS) 18,5:1	150,00 mm
40 310 6..						
	IN [2] 45,5 x 9 x 144,9	RA/S- Cr -	- 30° - -	5 - III	A 457 053 00 01 A 541 050 02 26	<b>160054</b>
	IN [2] 45,5 x 9 x 145,0 M + 1	S - Cr -	- 30° - -	5 - III	A 460 053 00 01 A 541 053 01 01	<b>16204</b>
	EX [2] 17,0 x 8 x 87,0	A - -	- 45° - -	9 -	A 541 016 05 91 A 541 016 06 91 A 541 016 07 91	<b>261101</b> (1)
	EX [2] 41,0 x 9 x 145,0	RA/S- Cr -	- 45° - -	5 - III	A 541 050 01 27 A 541 050 02 27	<b>160055</b>
	EX [2] 42,1 x 9 x 145,0	RA/S- Cr -	- 36° - -	5 - III	A 457 050 03 27 A 457 050 05 27	<b>16205</b>
	(1) Konstantdrosselventil - flach Exhaust brake valve - flat Soupape de réduction permanente - plate Válvula de reducción permanente - plana Постоянный дроссельный клапан					
	[50] Ø 9 mm				A 541 053 00 26 A 541 053 01 26 A 541 053 02 26	<b>LK-2615</b>
Fortsetzung nächste Seite / continued on next page / suite page suivante / continuación página próxima / Продолжение на следующей странице						

					Reference	Item No.
	IN/EX [4] 15,03 x 9 x 61,0	G2			A 457 053 12 30 A 541 053 12 30 A 541 053 27 30	<b>81-16103</b> (2)
	IN/EX [4] 15,24 x 9 x 61,0	G2			A 457 053 13 30 A 541 053 13 30 A 541 053 28 30	<b>81-16104</b> (2)
	(2) abweichend zu OE Bohrung fertigbearbeitet finish-machined with other than original bore usiné à un alésage différent de l'origine orificio mecanizado de manera diferente al original в отличие от OE отверстия расточено					
	IN [2] 47,38 x 40 x 7,7	G1 30°			A 541 053 17 31 A 541 053 21 31 A 541 053 26 31	<b>92-16157</b>
	EX [2] 43,10 x 34 x 8,0	G1 45°			A 541 053 05 32	<b>92-16158</b>
	EX [1] 43,10 x 34.4 x 7,8	G1 36°			A 457 053 13 32	<b>92-16170</b> <small>NEW</small>
	779,5 mm - 8,3 mm				A 542 050 14 01 A 542 050 17 01	<b>20 1003 50201</b> <b>20 1003 54200</b>
	[12] M 30 x 75				A 541 050 17 22 A 541 050 20 22	<b>20 1003 50062</b> <small>NEW</small> (3)
	(3) Mit 2 Ölbohrungen/with 2 oil holes/avec 2 trous d'huile/con 2 agujeros de aceite/c 2-мя смазочными отверстиями					
	I [1]				A 541 050 04 33 A 541 050 06 33 A 541 050 07 33 A 541 050 08 33 A 541 050 09 33 A 541 055 07 50	<b>20 1003 50010</b> (4)
	[1]				A 541 050 05 34 A 541 050 06 34 A 541 050 07 34 A 541 050 08 34	<b>20 1003 50011</b>
	(4) IN					

## 551 130

**OM 542 Euro 5 972**

D (LA) 8 15928 cm<sup>3</sup> 4V 405-480 kW (551-653 PS) 18,5:1 150,00 mm

**OM 942 992**

D (LA) 8 15928 cm<sup>3</sup> 4V 330-420 kW (449-571 PS) 150,00 mm

40 310 6.., 41 659 6..

	IN [2] 45,5 x 9 x 145,0 M + 1	S - Cr -	- 30° - -	5 - III	A 460 053 00 01 A 541 053 01 01	<b>16204</b>
	EX [2] 42,1 x 9 x 145,0	RA/S- Cr -	- 36° - -	5 - III	A 457 050 03 27 A 457 050 05 27	<b>16205</b>
	[50] Ø 9 mm				A 541 053 00 26 A 541 053 01 26 A 541 053 02 26	<b>LK-2615</b>
	IN/EX [4] 15,03 x 9 x 61,0	G2			A 457 053 12 30 A 541 053 12 30 A 541 053 27 30	<b>81-16103</b> (1)
	IN/EX [4] 15,24 x 9 x 61,0	G2			A 457 053 13 30 A 541 053 13 30 A 541 053 28 30	<b>81-16104</b> (1)
	(1) abweichend zu OE Bohrung fertigbearbeitet finish-machined with other than original bore usiné à un alésage différent de l'origine orificio mecanizado de manera diferente al original в отличие от OE отверстия расточено					

Fortsetzung nächste Seite / continued on next page / suite page suivante / continuación página próxima / Продолжение на следующей странице

					Reference	Item No.
EX [1]	43,10 x 34.4 x 7,8	G1 36°			A 457 053 13 32	<b>92-16170</b> <small>NEW</small>
					A 542 050 17 01	<b>20 1003 54200</b>
[12]	M 30 x 75				A 541 050 17 22 A 541 050 20 22	<b>20 1003 50062</b> <small>NEW</small> (2)
	(2) Mit 2 Ölbohrungen/with 2 oil holes/avec 2 trous d'huile/con 2 agujeros de aceite/c 2-мя смазочными отверстиями					
I [1]					A 541 050 04 33 A 541 050 06 33 A 541 050 07 33 A 541 050 08 33 A 541 050 09 33 A 541 055 07 50	<b>20 1003 50010</b> (3)
[1]					A 541 050 05 34 A 541 050 06 34 A 541 050 07 34 A 541 050 08 34	<b>20 1003 50011</b>
(3) IN						

## 552 130

OM 542 Euro 4/5 973

D (LA) 8 15928 cm<sup>3</sup> 4V

17,25:1 150,00 mm

40 310 6..

					A 542 050 17 01	<b>20 1003 54200</b>
--	--	--	--	--	-----------------	----------------------

## 553 130

OM 542 Euro 5 975

D (LA) 8 15928 cm<sup>3</sup> 4V

450 kW

(612 PS) 18,5:1 150,00 mm

IN [2]	45,5 x 9 x 144,9	RA/S- Cr -	- 30° - -	5 - III	A 457 053 00 01 A 541 050 02 26	<b>160054</b>
IN [2]	45,5 x 9 x 145,0 M + 1	S - Cr -	- 30° - -	5 - III	A 460 053 00 01 A 541 053 01 01	<b>16204</b>
EX [2]	17,0 x 8 x 87,0	A - -	- 45° - -	9 -	A 541 016 05 91 A 541 016 06 91 A 541 016 07 91	<b>261101</b> (1)
EX [2]	41,0 x 9 x 145,0	RA/S- Cr -	- 45° - -	5 - III	A 541 050 01 27 A 541 050 02 27	<b>160055</b>
EX [2]	42,1 x 9 x 145,0	RA/S- Cr -	- 36° - -	5 - III	A 457 050 03 27 A 457 050 05 27	<b>16205</b>
(1)	Konstantdrosselventil - flach Exhaust brake valve - flat Soupape de réduction permanente - plate Válvula de reducción permanente - plana Постоянный дроссельный клапан					

[50]	Ø 9 mm				A 541 053 00 26 A 541 053 01 26 A 541 053 02 26	<b>LK-2615</b>
------	--------	--	--	--	---	----------------

IN/EX [4]	15,03 x 9 x 61,0	G2			A 457 053 12 30 A 541 053 12 30 A 541 053 27 30	<b>81-16103</b> (2)
IN/EX [4]	15,24 x 9 x 61,0	G2			A 457 053 13 30 A 541 053 13 30 A 541 053 28 30	<b>81-16104</b> (2)

Fortsetzung nächste Seite / continued on next page / suite page suivante / continuación página próxima / Продолжение на следующей странице

					Reference	Item No.
	(2) abweichend zu OE Bohrung fertigbearbeitet finish-machined with other than original bore usiné à un alésage différent de l'origine orificio mecanizado de manera diferente al original в отличие от OE отверстие расточено					
	IN [2] 47,38 x 40 x 7,7	G1 30°			A 541 053 17 31 A 541 053 21 31 A 541 053 26 31	<b>92-16157</b>
	EX [2] 43,10 x 34 x 8,0	G1 45°			A 541 053 05 32	<b>92-16158</b>
	EX [1] 43,10 x 34.4 x 7,8	G1 36°			A 457 053 13 32	<b>92-16170</b> <small>NEW</small>
	779,5 mm - 8,3 mm				A 542 050 14 01	<b>20 1003 50201</b>
	[12] M 30 x 75				A 541 050 17 22 A 541 050 20 22	<b>20 1003 50062</b> <small>NEW</small> (3)
	(3) Mit 2 Ölbohrungen/with 2 oil holes/avec 2 trous d'huile/con 2 agujeros de aceite/c 2-мя смазочными отверстиями					
	I [1]				A 541 050 04 33 A 541 050 06 33 A 541 050 07 33 A 541 050 08 33 A 541 050 09 33 A 541 055 07 50	<b>20 1003 50010</b> (4)
	[1]				A 541 050 05 34 A 541 050 06 34 A 541 050 07 34 A 541 050 08 34	<b>20 1003 50011</b>
	(4) IN					

**554**
**130**
**OM 942**
**991**

D (LA) 8 15928 cm<sup>3</sup> 4V 448-480 kW (609-653 PS)

150,00 mm

41 659 6..

	IN [2] 45,5 x 9 x 145,0 M + 1	S - Cr -	- 30° - -	5 - III	A 460 053 00 01 A 541 053 01 01	<b>16204</b>
	EX [2] 42,1 x 9 x 145,0	RA/S- Cr -	- 36° - -	5 - III	A 457 050 03 27 A 457 050 05 27	<b>16205</b>
	[50] Ø 9 mm				A 541 053 00 26 A 541 053 01 26 A 541 053 02 26	<b>LK-2615</b>
	IN/EX [4] 15,03 x 9 x 61,0	G2			A 457 053 12 30 A 541 053 12 30 A 541 053 27 30	<b>81-16103</b> (1)
	IN/EX [4] 15,24 x 9 x 61,0	G2			A 457 053 13 30 A 541 053 13 30 A 541 053 28 30	<b>81-16104</b> (1)
	(1) abweichend zu OE Bohrung fertigbearbeitet finish-machined with other than original bore usiné à un alésage différent de l'origine orificio mecanizado de manera diferente al original в отличие от OE отверстие расточено					
	EX [1] 43,10 x 34.4 x 7,8	G1 36°			A 457 053 13 32	<b>92-16170</b> <small>NEW</small>
					A 542 050 17 01	<b>20 1003 54200</b>
Fortsetzung nächste Seite / continued on next page / suite page suivante / continuación página próxima / Продолжение на следующей странице						

					Reference	Item No.
[12]	M 30 x 75				A 541 050 03 22 A 541 050 05 22 A 541 050 07 22 A 541 050 13 22	<b>20 1003 50060</b> (2)
[12]	M 30 x 75				A 541 050 17 22 A 541 050 20 22	<b>20 1003 50062</b> <small>NEW</small> (3)
	(2) Rollenstößel/roller tappet/poussoir à galet/empujador de rodillos/роликовый толкатель					
	(3) Mit 2 Ölbohrungen/with 2 oil holes/avec 2 trous d'huile/con 2 agujeros de aceite/c 2-мя смазочными отверстиями					
I [1]					A 541 050 04 33 A 541 050 06 33 A 541 050 07 33 A 541 050 08 33 A 541 050 09 33 A 541 055 07 50	<b>20 1003 50010</b> (4)
[1]					A 541 050 05 34 A 541 050 06 34 A 541 050 07 34 A 541 050 08 34	<b>20 1003 50011</b>
	(4) IN					

**555**
**130**
**OM 942**
**993**

D (LA) 8 15928 cm<sup>3</sup> 4V 376-480 kW (510-653 PS)

150,00 mm

40 310 6..

IN [2]	45,5 x 9 x 145,0 M + 1	S - Cr -	- 30° - -	5 - III	A 460 053 00 01 A 541 053 01 01	<b>16204</b>
EX [2]	42,1 x 9 x 145,0	RA/S- Cr -	- 36° - -	5 - III	A 457 050 03 27 A 457 050 05 27	<b>16205</b>
[50]	∅ 9 mm				A 541 053 00 26 A 541 053 01 26 A 541 053 02 26	<b>LK-2615</b>
IN/EX [4]	15,03 x 9 x 61,0	G2			A 457 053 12 30 A 541 053 12 30 A 541 053 27 30	<b>81-16103</b> (1)
IN/EX [4]	15,24 x 9 x 61,0	G2			A 457 053 13 30 A 541 053 13 30 A 541 053 28 30	<b>81-16104</b> (1)
	(1) abweichend zu OE Bohrung fertigmachend finish-machined with other than original bore usiné à un alésage différent de l'origine orificio mecanizado de manera diferente al original в отличие от OE отверстие расточено					
IN [2]	47,38 x 40 x 7,7	G1 30°			A 541 053 17 31 A 541 053 21 31 A 541 053 26 31	<b>92-16157</b>
EX [2]	43,10 x 34 x 8,0	G1 45°			A 541 053 05 32	<b>92-16158</b>
EX [1]	43,10 x 34.4 x 7,8	G1 36°			A 457 053 13 32	<b>92-16170</b> <small>NEW</small>
					A 542 050 17 01	<b>20 1003 54200</b>
[12]	M 30 x 75				A 541 050 17 22 A 541 050 20 22	<b>20 1003 50062</b> <small>NEW</small> (2)
	(2) Mit 2 Ölbohrungen/with 2 oil holes/avec 2 trous d'huile/con 2 agujeros de aceite/c 2-мя смазочными отверстиями					

Fortsetzung nächste Seite / continued on next page / suite page suivante / continuación página próxima / Продолжение на следующей странице



					Reference	Item No.
	I [1]				A 541 050 04 33 A 541 050 06 33 A 541 050 07 33 A 541 050 08 33 A 541 050 09 33 A 541 055 07 50	20 1003 50010 (3)
	[1]				A 541 050 05 34 A 541 050 06 34 A 541 050 07 34 A 541 050 08 34	20 1003 50011
	(3) IN					

**556**
**132**
**OM 471 Euro 6**
**900, 906, 909**

07.2011 →

 D (LA) 6 12809 cm<sup>3</sup> 4V 310-375 kW (422-510 PS) 17,0:1 156,00 mm

	IN [2]	45,0 x 9,5 x 240,0	RA/S- Cr -	- 20° - -	9 - III	A 471 050 04 26 A 471 050 09 26 A 471 050 13 26	16211 <b>NEW</b>
	EX [2]	43,0 x 9,5 x 246,5	A/S - Cr -	- 30° - VS -	9 - III	A 471 050 05 27 A 471 050 09 27	16212 <b>NEW</b>
	[50]					A 472 053 00 26	RK-9.5H
	IN/EX [1]	15,04 x 9.5 x 98,1	G2				81-16110 <b>NEW</b>
		ES				A 471 050 13 01 A 471 050 17 01 A 471 050 18 01	20 1003 47100 20 1003 47101 (1) 20 1003 47102
		ES AS AS AS				A 471 050 20 01 A 471 050 19 01	20 1003 47103 (1) 20 1003 47104 (1)
	(1) (12)						
	IN [1]					A 471 050 00 33 A 471 050 03 33	20 1003 47110
	EX [2]					A 471 050 00 34 A 472 050 38 34 A 472 050 42 34	20 1003 47111 20 1003 47112 (2)
	[2]						
	(2)	Motorbremse engine break frein moteur freno motor устройство для торможения двигателем					

**557**
**132**
**OM 471 Euro 6**
**922, 944**

07.2011 →

 D (LA) 6 12809 cm<sup>3</sup> 4V 310-390 kW (422-530 PS) 156,00 mm

		ES				A 471 050 13 01 A 471 050 17 01 A 471 050 18 01	20 1003 47100 20 1003 47101 (1)
	(1) (12)						
	IN [1]					A 471 050 00 33 A 471 050 03 33	20 1003 47110
	EX [2]					A 471 050 00 34 A 472 050 38 34 A 472 050 42 34	20 1003 47111 20 1003 47112 (2)
	[2]						
	(2)	Motorbremse engine break frein moteur freno motor устройство для торможения двигателем					

					Reference	Item No.	
<b>558</b>		<b>132</b>					
<b>OM 471 Euro 6</b>	<b>926</b>	07.2011 →	D (LA)	6	12809 cm <sup>3</sup> 4V	310-390 kW (422-530 PS) 17	156,00 mm
	ES				A 471 050 13 01	<b>20 1003 47100</b>	
	ES				A 471 050 17 01	<b>20 1003 47101</b> (1)	
	AS				A 471 050 18 01	<b>20 1003 47102</b> (1)	
	AS				A 471 050 14 01	<b>20 1003 47103</b> (1)	
	AS				A 471 050 20 01	<b>20 1003 47104</b> (1)	
(1) (12)							
	IN [1]				A 471 050 00 33	<b>20 1003 47110</b>	
	EX [2]				A 471 050 03 33	<b>20 1003 47111</b>	
	[2]				A 471 050 00 34	<b>20 1003 47112</b> (2)	
	(2)	Motorbremse engine break frein moteur freno motor устройство для торможения двигателем			A 472 050 38 34		
					A 472 050 42 34		
<b>559</b>		<b>132</b>					
<b>OM 471 Euro 6</b>	<b>901, 910</b>		D (LA)	6	12809 cm <sup>3</sup> 4V	310-375 kW (422-510 PS) 17,0:1	156,00 mm
<b>OM 471 LA Euro 6</b>			D (LA)	6	12809 cm <sup>3</sup> 4V	310-375 kW (421-510 PS) 17,0:1	156,00 mm
	IN/EX [1]	15,04 x 9,5 x 98,1	G2				<b>81-16110</b> <small>NEW</small>
<b>560</b>		<b>132</b>					
<b>OM 471 Euro 6</b>	<b>902, 919</b>		D (LA)	6	12809 cm <sup>3</sup> 4V	310-375 kW (422-510 PS) 17,0:1	156,00 mm
	IN [2]	45,0 x 9,5 x 240,0	RA/S- Cr -	- 20° -	- 9 - III	A 471 050 04 26	<b>16211</b> <small>NEW</small>
						A 471 050 09 26	
						A 471 050 13 26	
	EX [2]	43,0 x 9,5 x 246,5	A/S - Cr -	- 30° - VS -	9 - III	A 471 050 05 27	<b>16212</b> <small>NEW</small>
						A 471 050 09 27	
	[50]					A 472 053 00 26	<b>RK-9.5H</b>
	IN/EX [1]	15,04 x 9,5 x 98,1	G2				<b>81-16110</b> <small>NEW</small>
	ES					A 471 050 13 01	<b>20 1003 47100</b>
	ES					A 471 050 17 01	<b>20 1003 47101</b> (1)
	AS					A 471 050 18 01	<b>20 1003 47102</b> (1)
	AS					A 471 050 14 01	<b>20 1003 47103</b> (1)
(1) (12)						A 471 050 20 01	
	IN [1]					A 471 050 00 33	<b>20 1003 47110</b>
	EX [2]					A 471 050 03 33	<b>20 1003 47111</b>
	[2]					A 471 050 00 34	<b>20 1003 47112</b> (2)
	(2)	Motorbremse engine break frein moteur freno motor устройство для торможения двигателем				A 472 050 38 34	
						A 472 050 42 34	

					Reference	Item No.
<b>561</b>		<b>132</b>				
<b>OM 471 Euro 6 903</b>						
D (LA) 6 12809 cm <sup>3</sup> 4V 310-375 kW (422-510 PS) 17,0:1 156,00 mm						
	IN [2]	45,0 x 9,5 x 240,0	RA/S- Cr -	- 20° -	- 9 - III	A 471 050 04 26 A 471 050 09 26 A 471 050 13 26 <b>16211</b> <small>NEW</small>
	EX [2]	43,0 x 9,5 x 246,5	A/S - Cr -	- 30° - VS -	9 - III	A 471 050 05 27 A 471 050 09 27 <b>16212</b> <small>NEW</small>
	IN/EX [1]	15,04 x 9.5 x 98,1	G2			<b>81-16110</b> <small>NEW</small>
	AS AS				A 471 050 14 01 A 471 050 20 01	<b>20 1003 47102</b> <b>20 1003 47103</b> (1)
	(1) (12)					
<b>562</b>		<b>132</b>				
<b>OM 471 Euro 6 905, 911, 913 - 914, 917, 920, 927, 932 - 935</b>						
D (LA) 6 12809 cm <sup>3</sup> 4V 306-375 kW (416-510 PS) 17,0:1 156,00 mm						
	IN/EX [1]	15,04 x 9.5 x 98,1	G2			<b>81-16110</b> <small>NEW</small>
	ES				A 471 050 13 01 A 471 050 17 01 A 471 050 18 01	<b>20 1003 47100</b> <b>20 1003 47101</b> (1)
	ES AS AS				A 471 050 14 01 A 471 050 20 01	<b>20 1003 47102</b> <b>20 1003 47103</b> (1)
	(1) (12)					
<b>563</b>		<b>132</b>				
<b>OM 471 Euro 6 915</b>						
D (LA) 6 12809 cm <sup>3</sup> 4V 310-375 kW (422-510 PS) 17,0:1 156,00 mm						
	IN/EX [1]	15,04 x 9.5 x 98,1	G2			<b>81-16110</b> <small>NEW</small>
	AS AS				A 471 050 14 01 A 471 050 20 01	<b>20 1003 47102</b> <b>20 1003 47103</b> (1)
	(1) (12)					
<b>564</b>		<b>132</b>				
<b>OM 471 Euro 6 928, 940 - 942</b>						
D (LA) 6 12809 cm <sup>3</sup> 4V 310-375 kW (422-510 PS) 156,00 mm						
	ES				A 471 050 13 01 A 471 050 17 01 A 471 050 18 01	<b>20 1003 47100</b> <b>20 1003 47101</b> (1)
	ES					
	(1) (12)					
<b>565</b>		<b>132</b>				
<b>OM 471 Euro 6 937</b>						
D (LA) 6 12809 cm <sup>3</sup> 4V 306-375 kW (416-510 PS) 17,3 156,00 mm						
	ES				A 471 050 13 01 A 471 050 17 01 A 471 050 18 01	<b>20 1003 47100</b> <b>20 1003 47101</b> (1)
	ES AS AS				A 471 050 14 01 A 471 050 20 01	<b>20 1003 47102</b> <b>20 1003 47103</b> (1)
	(1) (12)					

Fortsetzung nächste Seite / continued on next page / suite page suivante / continuación página próxima / Продолжение на следующей странице

					Reference	Item No.
	IN [1]				A 471 050 00 33	<b>20 1003 47110</b>
	EX [2]				A 471 050 03 33	
	[2]				A 471 050 00 34	<b>20 1003 47111</b>
	(2) Motorbremse engine break frein moteur freno motor устройство для торможения двигателем				A 472 050 38 34	<b>20 1003 47112 (2)</b>
					A 472 050 42 34	

**566**
**132**
**OM 471 Euro 6**
**946, 951**

D (LA) 6 12809 cm<sup>3</sup> 4V 310-375 kW (422-510 PS) 17,3 156,00 mm

**OM 471**
**945**

D (LA) 6 12809 cm<sup>3</sup> 4V 17,3 156,00 mm

IN [1]

EX [2]  
[2]

(1) Motorbremse  
engine break  
frein moteur  
freno motor  
устройство для торможения двигателем

A 471 050 00 33  
A 471 050 03 33  
A 471 050 00 34  
A 472 050 38 34  
A 472 050 42 34

**20 1003 47110**
**20 1003 47111**  
**20 1003 47112 (1)**
**M**
**567**
**139**
**OM 473 Euro 6**
**900, 903, 905**

07.2011 →

D (LA) 6 15569 cm<sup>3</sup> 4V 380-460 kW (517-626 PS) 17,0:1 171,00 mm

IN [2]

47,1 x 9,5 x 240,0

RA/S- Cr - - 20° - - 9 - III

A 472 050 02 26  
A 472 050 03 26  
A 473 050 01 26  
A 473 050 06 26

**162180** NEW

EX [2]

45,1 x 9,5 x 246,5

A/S - Cr - - 30° - VS - 9 - III

A 473 050 01 27  
A 473 050 02 27  
A 473 050 05 27

**162190** NEW

[50]

A 472 053 00 26

**RK-9.5H**

IN/EX [1]

15,04 x 9,5 x 98,1

G2

**81-16110** NEW

EX [2]

A 471 050 00 34

**20 1003 47111**
**568**
**139**
**OM 473 Euro 6**
**907, 914 - 915, 917**

07.2011 →

D (LA) 6 15569 cm<sup>3</sup> 4V 380-460 kW (517-626 PS) 171,00 mm

EX [2]

A 471 050 00 34

**20 1003 47111**
**569**
**139**
**OM 473 Euro 6**
**909, 919**

07.2011 →

D (LA) 6 15569 cm<sup>3</sup> 4V 380-460 kW (517-626 PS) 17,0:1 171,00 mm

IN/EX [1]

15,04 x 9,5 x 98,1

G2

**81-16110** NEW

EX [2]

A 471 050 00 34

**20 1003 47111**

					Reference	Item No.	
<b>570</b>		<b>139</b>					
<b>OM 472</b>	<b>900 - 904, 906 - 909</b>	D (LA) 6	14841 cm <sup>3</sup>	4V	335-512 kW (455-696 PS)	17,0:1 163,00 mm	
<b>OM 473 Euro 6</b>	<b>901 - 902, 908</b>	D (LA) 6	15569 cm <sup>3</sup>	4V	380-460 kW (517-626 PS)	17,0:1 171,00 mm	
	IN [2] 47,1 x 9,5 x 240,0	RA/S- Cr -	- 20° -	-	9 - III	A 472 050 02 26 A 472 050 03 26 A 473 050 01 26 A 473 050 06 26 <b>162180</b> <small>NEW</small>	
	EX [2] 45,1 x 9,5 x 246,5	A/S - Cr -	- 30° -	VS -	9 - III	A 473 050 01 27 A 473 050 02 27 A 473 050 05 27 <b>162190</b> <small>NEW</small>	
	[50]					A 472 053 00 26 <b>RK-9.5H</b>	
	IN/EX [1] 15,04 x 9.5 x 98,1	G2				<b>81-16110</b> <small>NEW</small>	
<b>571</b>		<b>139</b>					
<b>OM 472</b>	<b>905</b>	D (LA) 6	14841 cm <sup>3</sup>	4V		17,0:1 163,00 mm	
<b>OM 473 Euro 6</b>	<b>906</b>	D (LA) 6	15569 cm <sup>3</sup>	4V		17,0:1 171,00 mm	
	IN/EX [1] 15,04 x 9.5 x 98,1	G2				<b>81-16110</b> <small>NEW</small>	

	Cyl.		mm	cm <sup>3</sup>	Comp. Ratio $\epsilon$	kW	PS	Pos
CA16	B 4	78 x 83,6	1598	2	9:1	62	84	11
CA16D	B (NA) 4	78 x 83,6	1598	4	10:1	79-81	107-110	11
CA16DE	B (NA) 4	80 x 79,5	1598	4		85-91	116-124	14
CA16S	B (NA) 4	78 x 83,6	1598	2	9	60-66	82-90	11
CA18D	B (NA) 4	83 x 83,6	1809	4	10,5:1	92-99	125-129	21
CA18DE	B (NA) 4	83 x 83,6	1809	4	10,5	93-99	126-135	23
CA18DET Euro 1	B (A) 4	83 x 83,6	1809	4	8,5	124-148	169-201	22
CA18ET	B (A) 4	83 x 83,6	1809	2	8	90-100	122-136	21
CA18S	B (NA) 4	83 x 83,6	1809	2	8,8	65-74	88-101	21
CA18T	B (A) 4	83 x 83,6	1809	2	8:1	99	135	21
CA18i	B (NA) 4	83 x 83,6	1809	2	8,8	67	91	21
CA20E	B (NA) 4	84,5 x 88	1974	2	9,4	72-85	98-116	27
CA20S	B (NA) 4	84,5 x 88	1974	2	8,5	66-81	90-110	27
CD17	D (NA) 4	80 x 83,6	1681	2	22,2	40-41	54-56	16
CD20	D (NA) 4	84,5 x 88	1974	2	22,2	55-56	75-76	28
CD20ET	D (LA) 4	84,5 x 88	1974	2	22,2	71	97	29
CD20T	D (A) 4	84,5 x 88	1974	2	22,2	66-67	90-91	28
D4F 712	B (NA) 4	69 x 76,8	1149	4	9,8	55	75	2
D7F 764	B (NA) 4	69 x 76,8	1149	2	9,6	44	60	1
F4R 720	B (NA) 4	82,7 x 93	1998	4	9,8	88	120	19
F4R 722	B (NA) 4	82,7 x 93	1998	4	9,8	88	120	19
F4R 820	B (NA) 4	82,7 x 93	1998	4	9,8	86	117	20
F9Q 760	D (A) 4	80 x 93	1870	2	19	74	101	17
F9Q 762	D (A) 4	80 x 93	1870	2	19	60	82	17
F9Q 772	D (A) 4	80 x 93	1870	2	18,3	60	82	17
G9T 722	D (LA) 4	87 x 92	2188	4	18	66	90	38
G9U 650 Euro 4	D (LA) 4	89 x 99	2463	4	18,1	74-88	101-120	41
G9U 720 Euro 3	D (LA) 4	89 x 99	2463	4	21	73-84	99-114	41
G9U 730 Euro 3	D (LA) 4	89 x 99	2463	4	21	99	135	41
H4B 408	B (A) 3	72,2 x 73,1	898	4	9,5	66	90	5
HR12DE	BG (NA) 3	78 x 83,6	1198	4	10,5	50-95	68-129	10
HR16DE	AB (NA) 4	78 x 83,6	1598	4	10,7	64-103	87-140	12
HRA2DDT Euro 6	B (LA) 4	72 x 73,2	1198	4	10,0:1	85-88	116-120	3
HRA2DDT	B (A) 4	72,2 x 73,1	1197	4	10	85	116	4
ISB4-4H Euro 4	D (LA) 4	107 x 124	4500	4	17,3	136	185	44
ISB4-4L Euro 4	D (LA) 4	107 x 124	4500	4	17,3	103	140	44
ISB4-6H Euro 4	D (LA) 6	107 x 124	6700	4		184	250	44
ISB4-6L Euro 4	D (LA) 6	107 x 124	6700	4		165	224	44
K4M 752	B (NA) 4	79,5 x 80,5	1598	4	10	70	95	13
K9K 270	D (LA) 4	76 x 80,5	1461	4	18,8:1	63	86	7
K9K 270	D (A) 4	76 x 80,5	1461	2	16	78-81	106-110	7
K9K 274	D (LA) 4	76 x 80,5	1461	2	18,8:1	50	68	7
K9K 276	D (LA) 4	76 x 80,5	1461	2	18,8	62-66	84-90	7
K9K 278	D (A) 4	76 x 80,5	1461	2	15,3	76-78	103-106	7
K9K 282	D (A) 4	76 x 80,5	1461	2	15,3	76-78	103-106	7
K9K 292	D (A) 4	76 x 80,5	1461	2	15,3	76-78	103-106	7
K9K 400 Euro 4	D (A) 4	76 x 80,5	1461	2	15,9	63	86	7
K9K 410	D (A) 4	76 x 80,5	1461	2		81	110	7
K9K 430	D (A) 4	76 x 80,5	1461	2		81	110	7
K9K 608 Euro 5	D (A) 4	76 x 80,5	1461	2	15,9	63-66	86-90	7
K9K 628 Euro 6	D (A) 4	76 x 80,5	1461	2	15,9	63-66	86-90	7
K9K 636 Euro 5	D (A) 4	76 x 80,5	1461	2	15,2	81	110	7
K9K 646 Euro 6	D (A) 4	76 x 80,5	1461	2	15,2	81	110	7
K9K 700	D (A) 4	76 x 80,5	1461	2	18,8	47-50	64-68	6
K9K 702	D (A) 4	76 x 80,5	1461	2	18,8	60	82	9
K9K 704	D (A) 4	76 x 80,5	1461	2	18,8	47-48	64-65	6
K9K 708	D (A) 4	76 x 80,5	1461	2	18,8	48-50	65-68	7
K9K 710	D (A) 4	76 x 80,5	1461	2	18,8	42-45	57-61	6
K9K 714	D (A) 4	76 x 80,5	1461	2	18,8	42-45	57-61	6
K9K 716	D (A) 4	76 x 80,5	1461	2	18,8	50-51	68-69	7
K9K 718	D (A) 4	76 x 80,5	1461	2	18,8	50-62	68-84	8
K9K 722	D (A) 4	76 x 80,5	1461	2	18,8	60	82	6
K9K 728	D (A) 4	76 x 80,5	1461	2	18,8	74-78	101-106	9
K9K 732	D (A) 4	76 x 80,5	1461	2	18,8	78	106	7
K9K 764	D (A) 4	76 x 80,5	1461	2	15,6	78	106	7
K9K 772	D (A) 4	76 x 80,5	1461	2	15,6	63-76	86-103	7
K9K 872 Euro 6	D (A) 4	76 x 80,5	1461	2		59-85	80-116	7
K9K 892 Euro 4	D (A) 4	76 x 80,5	1461	2	15,9	66	90	8
K9K 896 Euro 5	D (A) 4	76 x 80,5	1461	2	15,5	81	110	8



		Cyl.		mm	cm <sup>3</sup>		Comp. Ratio $\epsilon$	kW	PS	Pos
M1D Euro 4	D (LA)	4	84 x 90	1994	4	15,3	110	150	26	
M9R	D (LA)	4	84 x 90	1995	4	16	110-130	150-177	26	
M9R 630	D (LA)	4	84 x 90	1995	4	15,5	66-84	90-114	24	
M9R 760	D (LA)	4	84 x 90	1995	4	16	127-130	173-177	26	
M9R 780 Euro 4	D (LA)	4	84 x 90	1995	4	16	66-84	90-114	25	
M9R 782	D (LA)	4	84 x 90	1995	4	17	66	90	25	
M9T	D (LA)	4	85 x 101,3	2299	4	16	74-125	100-170	32	
M9T 670 Euro 5	D (A)	4	85 x 101,3	2299	4	16	74-92	101-125	32	
M9T 672 Euro 5	D (A)	4	85 x 101,3	2299	4	16	74-92	101-125	32	
M9T 676 Euro 4	D (A)	4	85 x 101,3	2299	4	16	74-92	101-125	32	
M9T 678	D (A)	4	85 x 101,3	2299	4	16	107	146	32	
M9T 680	D (A)	4	85 x 101,3	2299	4	16	92-107	125-145	32	
M9T 686 Euro 5	D (A)	4	85 x 101,3	2299	4	16	92	125	32	
M9T 690 Euro 5	D (A)	4	85 x 101,3	2299	4	16	74-92	101-125	32	
M9T 692 Euro 4	D (A)	4	85 x 101,3	2299	4	16	66-92	90-125	32	
M9T 694 Euro 4	D (A)	4	85 x 101,3	2299	4	16	107	146	32	
M9T 696 Euro 4	D (A)	4	85 x 101,3	2299	4	16	92-107	125-146	32	
M9T 698 Euro 5	D (A)	4	85 x 101,3	2299	4	16	92-107	125-146	32	
M9T 702 Euro 5	D (A)	4	85 x 101,3	2299	4	16	100-120	136-163	32	
M9T 706 Euro 4/5	D (A)	4	85 x 101,3	2299	4	16	107-125	145-170	32	
M9T 870 Euro 5	D (A)	4	85 x 101,3	2299	4	16	74-92	100-125	32	
M9T 880 Euro 5	D (A)	4	85 x 101,3	2299	4	16	110	150	32	
M9T 896 Euro 4	D (A)	4	85 x 101,3	2299	4	16	92-110	125-150	32	
QG18DE	B (NA)	4	80 x 88	1769	4	9,5	78-94	106-128	15	
R9M	D (A)	4	80 x 79,5	1598	4	15,4	70-107	95-146	18	
R9M 413	D (A)	4	80 x 79,5	1598	4	15,4	70-89	95-121	18	
R9M 452	D (A)	4	80 x 79,5	1598	4	15,4	92-118	125-160	18	
RD28	D (NA)	6	85 x 83	2826	2	21,2	66-69	90-94	30	
RD28T	D (A)	6	85 x 83	2826	2	21,2	74-86	101-117	31	
RD28Ti	D (A)	6	85 x 83	2826	2	21	95-96	129-131	31	
SR20DI	B (NA)	4	86 x 86	1998	4	9,5	85	116	33	
SR20De	B (NA)	4	86 x 86	1998	4	9,5	85	115	34	
YD22D	D (NA)	4	86 x 94	2184	4	16,7	84	114	35	
YD22DCi	D (LA)	4	86 x 94	2184	4	18:1	100-102	136-139	35	
YD22DDT	D (A)	4	86 x 94	2184	4	18	81-102	110-139	36	
YD22DDTi	D (LA)	4	86 x 94	2184	4	16,7	84-110	114-150	36	
YD22ETI	D (LA)	4	86 x 94	2184	4	16,3	84-100	114-136	37	
YD25DDTi	D (LA)	4	89 x 100	2488	4	17,5-18	76-140	103-190	39	
YD25EFi	D (LA)	4	89 x 100	2488	4		98	133	43	
YD25ETI	D (LA)	4	89 x 100	2488	4	16,3	96-98	131-133	40	
YD25K3LD-5MI	D (LA)	4	89 x 100	2488	4	15,9	100	136	42	

N

			Pos				Pos
				1.8i Turbo 16V	07.1986 → 05.1990	CA18DET	B 22
<b>180 NX</b>				<b>BLUEBIRD (T72, T12, U12)</b>			
2.0i 16V	01.1991 → 10.1994	SR20De	B 34	1.6	12.1985 → 02.1990	CA16S	B 11
<b>180SX Coupe (S13)</b>				1.6	03.1986 → 06.1990	CA16S	B 11
1.8	09.1988 → 06.1992	CA18DE	B 23	1.8	11.1986 → 04.1990	CA18S	B 21
1.8	09.1988 → 06.1992	CA18DET	B 22	1.8 Turbo	12.1985 → 05.1990	CA18T	B 21
1.8 Turbo II	04.1989 → 06.1992	CA18DET	B 22	1.8 i 16V (RLT72)	02.1989 → 12.1990	CA18D	B 21
<b>200 SX</b>				2.0 (T12)	12.1985 → 12.1987	CA20S	B 27
1.8	11.1983 → 06.1988	CA18S	B 21	2.0 LX	12.1985 → 02.1990	CA20S	B 27
2.0i	01.1983 → 07.1989	CA20E	B 27	2.0 i	09.1988 → 09.1990	CA20E	B 27
<b>200SX (S13)</b>				2.0 i (HLT72, T12)	12.1985 → 12.1990	CA20E	B 27
1.8	09.1988 → 03.1994	CA18DE	B 23	2.0 i (HLT72, T12)	12.1985 → 12.1990	CA20S	B 27
1.8 Turbo	07.1988 → 11.1993	CA18DET	B 22	<b>BLUEBIRD (U11)</b>			
<b>ALMERA (N17)</b>				1.6	12.1985 → 02.1990	CA16S	B 11
1.2 i	09.2011 →	HR12DE	BG 10	1.6 DX	11.1983 → 02.1988	CA16S	B 11
1.6	04.2014 →	HR16DE	AB 12	1.8	11.1983 → 06.1988	CA18S	B 21
1.6	03.2019 →	HR16DE	AB 12	1.8 Turbo	04.1984 → 05.1990	CA18T	B 21
<b>ALMERA (N18_)</b>				2.0	12.1985 → 01.1988	CA20E	B 27
1.6	09.2019 →	HR16DE	AB 12	2.0	12.1985 → 02.1990	CA20S	B 27
1.6	09.2019 →	HR16DE	AB 12	2.0 i	04.1984 → 01.1988	CA20E	B 27
1.6 SENSE / ADVANCE / EXCLUSIVE	10.2020 →	HR16DE	AB 12	<b>BLUEBIRD (U13, U14)</b>			
<b>ALMERA I (N15)</b>				2.0 D	09.1991 → 12.1995	CD20	D 28
1.8	07.1995 → 05.2000	QG18DE	B 15	2.0 D	04.1997 → 05.2002	CD20	D 28
2.0 D	11.1995 → 07.2000	CD20	D 28	2.0 D AWD	09.1991 → 12.1995	CD20	D 28
<b>ALMERA I Hatchback (N15)</b>				<b>BLUEBIRD (U14)</b>			
1.8	07.1995 → 05.2000	QG18DE	B 15	1.8	09.1998 → 08.2001	QG18DE	B 15
2.0 D	11.1995 → 03.2000	CD20	D 28	<b>BLUEBIRD Hatchback (T72, T12)</b>			
<b>ALMERA II (N16)</b>				1.6	03.1986 → 06.1990	CA16S	B 11
1.5 dCi	01.2003 → 09.2006	K9K 722	D 6	1.6	03.1986 → 06.1991	CA16S	B 11
1.8	06.2000 →	QG18DE	B 15	1.8 Turbo	12.1985 → 11.1992	CA18T	B 21
1.8	07.2000 → 11.2002	QG18DE	B 15	1.8 i 16V (FRLT72)	02.1989 → 12.1990	CA18D	B 21
1.8	01.2002 →	QG18DE	B 15	2.0 (T12)	12.1985 → 12.1987	CA20S	B 27
1.8	10.2002 → 09.2006	QG18DE	B 15	2.0 i	09.1988 → 09.1990	CA20E	B 27
2.2 Di	07.2000 → 04.2003	YD22DDT	D 36	2.0 i (FHLT72, T12)	12.1985 → 12.1990	CA20E	B 27
2.2 dCi	09.2003 → 09.2006	YD22DDT	D 36	<b>BLUEBIRD SYLPHY / SYLPHY III (B17)</b>			
2.2 dCi	09.2003 → 09.2006	YD22DDTi	D 36	1.6	08.2012 →	HR16DE	AB 12
<b>ALMERA II Hatchback (N16)</b>				1.6	05.2013 →	HR16DE	AB 12
1.5 dCi	01.2003 → 09.2006	K9K 722	D 6	1.6 CNG	01.2013 →	HR16DE	AB 12
1.8	01.2000 → 11.2002	QG18DE	B 15	<b>BLUEBIRD SYLPHY I (G10, N16)</b>			
1.8	08.2002 →	QG18DE	B 15	1.8	01.2000 → 06.2006	QG18DE	B 15
1.8	10.2002 → 09.2006	QG18DE	B 15	1.8	01.2000 → 06.2006	QG18DE	B 15
2.2 Di	03.2000 → 04.2003	YD22DDT	D 36	1.8	08.2002 → 08.2005	QG18DE	B 15
2.2 dCi	09.2003 → 09.2006	YD22DDT	D 36	1.8 4WD	01.2000 → 07.2002	QG18DE	B 15
2.2 dCi	09.2003 → 09.2006	YD22DDTi	D 36	1.8 4WD	08.2000 → 07.2002	QG18DE	B 15
<b>ALMERA TINO (V10)</b>				<b>BLUEBIRD Saloon (910)</b>			
1.8	12.1998 → 02.2003	QG18DE	B 15	2.0	12.1985 → 06.1986	CA20S	B 27
1.8	08.2000 → 02.2006	QG18DE	B 15	<b>BLUEBIRD Station Wagon (WU11)</b>			
1.8	12.2002 → 02.2006	QG18DE	B 15	1.6	12.1985 → 02.1990	CA16S	B 11
2.2 dCi	08.2000 → 02.2006	YD22DDTi	D 36	1.8	11.1983 → 04.1990	CA18S	B 21
2.2 dCi	08.2000 → 02.2006	YD22DDTi	D 36	1.8 Turbo	09.1984 → 04.1990	CA18ET	B 21
2.2 dCi	09.2003 → 02.2006	YD22DDT	D 36	2.0	04.1986 → 09.1990	CA20S	B 27
2.2 dCi	09.2003 → 02.2006	YD22DDTi	D 36	2.0 LX	12.1985 → 02.1990	CA20S	B 27
<b>AUSTER (T12)</b>				2.0 i	04.1984 → 12.1990	CA20E	B 27
1.8 Turbo	04.1987 → 10.1989	CA18ET	B 21	2.0 i	09.1988 → 09.1990	CA20E	B 27
1.8 Turbo	04.1987 → 10.1989	CA18T	B 21	<b>BLUEBIRD Traveller (W910)</b>			
1.8 Xt	04.1987 → 10.1989	CA18DET	B 22	2.0	04.1985 → 06.1986	CA20S	B 27
2.0	06.1986 → 10.1989	CA20S	B 27	<b>CEDRIC (Y30)</b>			
<b>AVENIR (W10, PW10)</b>				2.0	05.1984 → 08.1987	CA20S	B 27
2.0	06.1986 → 10.1990	CA20S	B 27	2.0	05.1984 → 08.1987	CA20S	B 27
2.0	10.1989 → 10.1997	CA20E	B 27	2.8 D	07.1985 → 08.1997	RD28	D 30
2.0 TD	09.1996 → 10.1997	CD20T	D 28	<b>CEDRIC (Y32)</b>			
<b>AVENIR (W11)</b>				2.8 D	06.1991 → 10.1995	RD28T	D 31
1.8	11.1997 → 12.2005	QG18DE	B 15	2.8 TD	06.1991 → 10.1995	RD28	D 30
2.0 TD	11.1997 → 09.1999	CD20T	D 28	<b>CEDRIC (Y33)</b>			
<b>BASSARA</b>				2.8 TD	11.1995 → 07.1998	RD28T	D 31
2.5 DCi	11.1999 → 08.2003	YD25DDTi	D 39	<b>CEDRIC Hardtop (Y31)</b>			
<b>BLUEBIRD (B610)</b>				2.8 D	09.1987 → 05.1991	RD28	D 30
				<b>CHERRY III (N12)</b>			
				1.7 D	10.1982 → 12.1986	CD17	D 16

					Pos						Pos
<b>CIVILIAN</b>					<b>MICRA III (K12)</b>						
2.8 TD		RD28T	D	<b>31</b>	1.5 dCi	01.2003 → 06.2010	K9K 704	D	<b>6</b>		
<b>CREW ( _K30 )</b>					<b>MICRA IV (K13K)</b>						
2.8 D (SK30)	06.1993 → 08.2003	RD28	D	<b>30</b>	1.5 dCi	09.2003 → 06.2010	K9K 722	D	<b>6</b>		
<b>CUBE (Z12)</b>					<b>MICRA IV (K13K)</b>						
1.5 dCi	10.2009 →	K9K 270	D	<b>7</b>	1.5 dCi	06.2005 → 06.2010	K9K 276	D	<b>7</b>		
1.5 dCi	03.2010 →	K9K 270	D	<b>7</b>	160 SR	05.2005 → 06.2010	HR16DE	AB	<b>12</b>		
1.6 16V	08.2009 →	HR16DE	AB	<b>12</b>	<b>MICRA IV (K13K)</b>						
<b>DUALIS</b>					1.2	05.2010 →	HR12DE	BG	<b>10</b>		
1.5 dCi 16V	04.2007 →	K9K 292	D	<b>7</b>	1.2	05.2010 →	HR12DE	BG	<b>10</b>		
1.6i 16V	11.2006 →	HR16DE	AB	<b>12</b>	1.2	05.2010 →	HR12DE	BG	<b>10</b>		
2.0 dCi 16V	04.2007 →	M9R	D	<b>26</b>	1.2	01.2013 →	HR12DE	BG	<b>10</b>		
<b>EXA Targa (N13)</b>					1.2 4WD	05.2010 →	HR12DE	BG	<b>10</b>		
1.6 i (KEN13)	02.1987 → 12.1987	CA16DE	B	<b>14</b>	1.2 Active	07.2013 →	HR12DE	BG	<b>10</b>		
1.8 i (KCN13)	07.1987 → 10.1991	CA18DE	B	<b>23</b>	1.2 LPG	05.2010 →	HR12DE	BG	<b>10</b>		
<b>EXPERT II (W11)</b>					1.5 D	11.2010 →	K9K 700	D	<b>6</b>		
1.8	10.1998 → 04.2004	QG18DE	B	<b>15</b>	1.5 D	11.2010 →	K9K 704	D	<b>6</b>		
2.2 D	10.1998 → 04.2004	YD22D	D	<b>35</b>	1.6	09.2011 →	HR16DE	AB	<b>12</b>		
<b>GLORIA</b>					1.6	07.2014 →	HR16DE	AB	<b>12</b>		
2.8 TD	06.1991 → 10.1995	RD28	D	<b>30</b>	1.6	02.2016 →	HR16DE	AB	<b>12</b>		
<b>GLORIA VII (Y30)</b>					1.6 Flex	10.2011 →	HR16DE	AB	<b>12</b>		
2.0	05.1984 → 08.1987	CA20S	B	<b>27</b>	<b>MICRA IV (K13KK)</b>						
<b>JUKE (F15)</b>					1.2	01.2013 →	HR12DE	BG	<b>10</b>		
1.2 DIG-T	05.2014 →	HRA2DDT	B	<b>4</b>	1.2	10.2015 →	HR12DE	BG	<b>10</b>		
1.5 dCi	06.2010 →	K9K 410	D	<b>7</b>	1.2	10.2015 →	HR12DE	BG	<b>10</b>		
1.5 dCi	06.2010 →	K9K 636	D	<b>7</b>	1.6	01.2015 →	HR16DE	AB	<b>12</b>		
1.5 dCi	06.2010 →	K9K 646	D	<b>7</b>	<b>MICRA V (K14)</b>						
1.5 dCi	06.2010 →	K9K 896	D	<b>8</b>	0.9 IG-T	12.2016 →	H4B 408	B	<b>5</b>		
1.6	06.2010 →	HR16DE	AB	<b>12</b>	1.5 DCI	12.2016 →	K9K 628	D	<b>7</b>		
1.6	01.2013 →	HR16DE	AB	<b>12</b>	<b>MURANO II (Z51)</b>						
1.6	03.2016 →	HR16DE	AB	<b>12</b>	2.5 dCi 4x4	01.2010 → 09.2014	YD25DDTi	D	<b>39</b>		
1.6	07.2018 →	HR16DE	AB	<b>12</b>	<b>NAVARA (D22)</b>						
1.6 CVTC	08.2014 →	HR16DE	AB	<b>12</b>	2.5 D	01.2008 →	YD25DDTi	D	<b>39</b>		
1.6 Flexfuel	06.2010 →	HR16DE	AB	<b>12</b>	2.5 D 4x4	11.2001 →	YD25DDTi	D	<b>39</b>		
1.6 LPG	01.2012 →	HR16DE	AB	<b>12</b>	2.5 D 4x4	01.2008 →	YD25DDTi	D	<b>39</b>		
1.6 LPG	09.2018 →	HR16DE	AB	<b>12</b>	<b>NOTE</b>						
<b>KICKS (P15 _)</b>					1.2 HYBRID E-POWER	02.2021 →	HR12DE	BG	<b>10</b>		
1.2 Combined e-Power	03.2020 →	HR12DE	BG	<b>10</b>	<b>NOTE (E11, NE11)</b>						
1.2 e-Power	03.2020 →	HR12DE	BG	<b>10</b>	1.5 dCi	03.2006 → 06.2012	K9K 276	D	<b>7</b>		
1.6	11.2016 →	HR16DE	AB	<b>12</b>	1.5 dCi	03.2006 → 06.2012	K9K 700	D	<b>6</b>		
1.6	09.2018 →	HR16DE	AB	<b>12</b>	1.5 dCi	09.2010 → 06.2012	K9K 276	D	<b>7</b>		
1.6 Flex	01.2017 →	HR16DE	AB	<b>12</b>	1.6	03.2006 → 06.2012	HR16DE	AB	<b>12</b>		
<b>LARGO MPV (W30)</b>					<b>NOTE (E12)</b>						
2.0 TD (W30)	06.1993 → 06.1999	CD20	D	<b>28</b>	1.2	06.2013 →	HR12DE	BG	<b>10</b>		
2.0 TD (W30)	06.1993 → 06.1999	CD20T	D	<b>28</b>	1.2	06.2013 →	HR12DE	BG	<b>10</b>		
2.0 TD AWD (W30)	06.1993 → 06.1999	CD20	D	<b>28</b>	1.2 4WD	06.2013 →	HR12DE	BG	<b>10</b>		
2.0 TD AWD (W30)	06.1993 → 06.1999	CD20T	D	<b>28</b>	1.2 Hybrid e-Power	10.2016 →	HR12DE	BG	<b>10</b>		
<b>LATIO Saloon (N17)</b>					1.2 LPG	03.2015 →	HR12DE	BG	<b>10</b>		
1.6	03.2007 →	HR16DE	AB	<b>12</b>	1.5 dCi	06.2013 →	K9K 608	D	<b>7</b>		
<b>LAUREL (JC31)</b>					1.5 dCi	06.2013 →	K9K 892	D	<b>8</b>		
2.0 GL	11.1984 → 12.1985	CA20S	B	<b>27</b>	1.6	06.2013 →	HR16DE	AB	<b>12</b>		
<b>LAUREL (JC32)</b>					1.6	06.2013 →	HR16DE	AB	<b>12</b>		
2.0 GL	11.1984 → 12.1985	CA20S	B	<b>27</b>	1.6 NISMO S	06.2013 →	HR16DE	AB	<b>12</b>		
2.8 D	01.1985 → 12.1989	RD28	D	<b>30</b>	<b>NP200</b>						
<b>LIBERTA</b>					1.6	10.2008 →	HR16DE	AB	<b>12</b>		
2.0	07.1986 → 06.1990	CA20S	B	<b>27</b>	<b>NP300 NAVARA (D40)</b>						
<b>LIVINA / GRAND LIVINA (L10, L11)</b>					2.5 D	09.2008 →	YD25DDTi	D	<b>39</b>		
1.6	02.2007 →	HR16DE	AB	<b>12</b>	2.5 D 4WD	09.2008 →	YD25DDTi	D	<b>39</b>		
1.6	03.2014 →	HR16DE	AB	<b>12</b>	2.5 dCi	07.2005 →	YD25DDTi	D	<b>39</b>		
1.6 (L10L, NTL10L)	03.2009 →	HR16DE	AB	<b>12</b>	2.5 dCi	12.2005 →	YD25DDTi	D	<b>39</b>		
1.6 CVTC	05.2013 →	HR16DE	AB	<b>12</b>	2.5 dCi	10.2006 →	YD25DDTi	D	<b>39</b>		
<b>LUCINO Saloon</b>					2.5 dCi	11.2012 →	YD25DDTi	D	<b>39</b>		
2.0 D	11.1997 → 01.2000	CD20	D	<b>28</b>	2.5 dCi 4WD	07.2005 →	YD25DDTi	D	<b>39</b>		
<b>MARCH</b>					2.5 dCi 4WD	10.2006 →	YD25DDTi	D	<b>39</b>		
1.5 dCi	02.2003 →	K9K 700	D	<b>6</b>	2.5 dCi 4WD	01.2007 →	YD25DDTi	D	<b>39</b>		
1.5 dCi	02.2003 →	K9K 704	D	<b>6</b>	2.5 dCi 4WD	11.2012 →	YD25DDTi	D	<b>39</b>		
1.6i 16V	07.2005 →	HR16DE	AB	<b>12</b>	2.5 dCi 4WD (D40TT, D40T, D40M, D40BB)	12.2009 →	YD25DDTi	D	<b>39</b>		
<b>MICRA C+C III (K12)</b>					2.5 dCi 4x4	02.2012 → 12.2016	YD25DDTi	D	<b>39</b>		
1.6 160 SR	08.2005 →	HR16DE	AB	<b>12</b>	<b>NP300 NAVARA Pickup (D23)</b>						

N

			Pos				Pos
2.5 dCi	09.2020 →	YD25DDTi	D	39	<b>PRIMERA (P10)</b>		
2.5 dCi AWD	09.2020 →	YD25DDTi	D	39	2.0 16V	06.1990 → 01.1996	SR20DI B 33
2.5 dCi	07.2014 →	YD25DDTi	D	39	2.0 16V 4x4	04.1991 → 06.1996	SR20DI B 33
2.5 dCi	07.2014 →	YD25DDTi	D	39	2.0 D	01.1991 → 01.1996	CD20 D 28
2.5 dCi 4x4	07.2014 →	YD25DDTi	D	39	<b>PRIMERA (P11)</b>		
2.5 dCi 4x4	07.2014 →	YD25DDTi	D	39	1.8 16V	08.1999 → 12.2001	QG18DE B 15
<b>NP300 PICKUP (D22)</b>					2.0 16V	09.1996 → 12.2001	SR20De B 34
2.5 dCi	04.2008 →	YD25DDTi	D	39	2.0 TD	09.1996 → 12.2001	CD20T D 28
2.5 dCi 4x4	04.2008 →	YD25DDTi	D	39	<b>PRIMERA (P12)</b>		
<b>PATHFINDER III (R51)</b>					1.8	03.2002 → 10.2008	QG18DE B 15
2.5 dCi	01.2005 →	YD25DDTi	D	39	1.8 LPG	03.2002 →	QG18DE B 15
2.5 dCi	10.2012 → 08.2014	YD25DDTi	D	39	2.2 Di	03.2002 → 05.2007	YD22DDT D 36
2.5 dCi 4WD	01.2005 →	YD25DDTi	D	39	2.2 dCi	04.2003 → 04.2006	YD22DDT D 36
2.5 dCi 4WD	03.2005 →	YD25DDTi	D	39	<b>PRIMERA Estate (WP12)</b>		
2.5 dCi 4WD	10.2006 →	YD25DDTi	D	39	1.8	03.2002 → 05.2007	QG18DE B 15
2.5 dCi 4WD	08.2010 →	YD25DDTi	D	39	2.2 Di	03.2002 → 04.2003	YD22DDT D 36
<b>PATROL GR IV (Y60, GR)</b>					2.2 dCi	04.2003 →	YD22DDT D 36
2.8 D	01.1986 → 02.1998	RD28T	D	31	<b>PRIMERA Hatchback (P10)</b>		
2.8 TD	10.1995 → 02.1998	RD28T	D	31	2.0 16V	06.1990 → 01.1996	SR20DI B 33
2.8 TD (Y60A)	09.1988 → 06.1997	RD28T	D	31	2.0 16V 4x4	04.1991 → 06.1996	SR20DI B 33
<b>PATROL GR V Wagon (Y61)</b>					2.0 D	01.1991 → 01.1996	CD20 D 28
2.8 D	03.1998 → 04.2001	RD28T	D	31	<b>PRIMERA Hatchback (P11)</b>		
2.8 TD	06.1997 → 05.2000	RD28Ti	D	31	1.8 16V	08.1999 → 07.2002	QG18DE B 15
2.8 TDiC (Y61)	10.1997 → 02.2000	RD28Ti	D	31	2.0 16V	09.1996 → 07.2002	SR20De B 34
<b>PATROL III/2 Hardtop (K260)</b>					2.0 TD	09.1996 → 07.2002	CD20T D 28
2.8 D	03.1989 → 03.1996	RD28	D	30	<b>PRIMERA Hatchback (P12)</b>		
2.8 TD	05.1986 → 06.1990	RD28T	D	31	1.8	07.2002 → 10.2008	QG18DE B 15
<b>PATROL III/2 Station Wagon (W260)</b>					2.2 Di	07.2002 → 05.2007	YD22DDT D 36
2.8 D 4x4	03.1989 → 03.1996	RD28	D	30	2.2 dCi	04.2003 →	YD22DDT D 36
2.8 D 4x4	01.1990 → 01.1991	RD28	D	30	<b>PRIMERA Traveller (W10)</b>		
2.8 TD	06.1989 → 11.1995	RD28T	D	31	2.0 D	07.1990 → 12.1995	CD20 D 28
2.8 TD 4x4	03.1992 → 06.1993	RD28T	D	31	2.0 i	07.1990 → 03.1998	SR20DI B 33
<b>PICK UP (D22)</b>					<b>PRIMERA Traveller (WP11)</b>		
2.5 Di	03.2002 → 12.2010	YD25DDTi	D	39	1.8 16V	08.1999 → 12.2001	QG18DE B 15
2.5 dCi 4WD	03.2002 →	YD25DDTi	D	39	1.8 16V LPG	08.1999 → 12.2001	QG18DE B 15
2.5 dCi 4WD	01.2013 →	YD25DDTi	D	39	2.0 16V	06.1996 → 12.2001	SR20De B 34
<b>PINTARA</b>					2.0 TD	04.1998 → 12.2001	CD20T D 28
2.0i	06.1986 → 10.1992	CA20E	B	27	<b>PULSAR</b>		
<b>PINTARA Estate (R31)</b>					1.6i 16V	09.1986 → 12.1987	CA16DE B 14
2.0 i	06.1986 → 10.1990	CA20E	B	27	1.6i 16V	02.1987 → 10.1988	CA16D B 11
<b>PINTARA Hatchback (U12)</b>					1.7 D	04.1982 → 08.1990	CD17 D 16
2.0 i	11.1990 → 10.1992	CA20E	B	27	1.8i 16V	10.1988 → 08.1990	CA18D B 21
<b>PINTARA Saloon (R31)</b>					1.8i 16V	10.1988 → 08.1990	CA18DE B 23
2.0 i	06.1986 → 10.1990	CA20E	B	27	2.0i 16V	08.1995 → 06.2000	SR20De B 34
<b>PINTARA Saloon (U12)</b>					<b>PULSAR Hatchback (C13)</b>		
2.0 i	11.1989 → 10.1992	CA20E	B	27	1.2 DIG-T	10.2014 →	HRA2DDT B 4
<b>PRAIRIE</b>					<b>PULSAR NX Coupe</b>		
2.0i 16V	08.1995 → 11.1998	SR20De	B	34	1.6	09.1986 → 12.1987	CA16DE B 14
<b>PRAIRIE (M10, NM10)</b>					1.8	09.1987 → 12.1989	CA18DE B 23
1.8 SGL (M10)	07.1983 → 12.1985	CA18S	B	21	<b>QASHQAI / QASHQAI + 2 I (J10, NJ10, JJ10E)</b>		
1.8 SGL (M10)	05.1985 → 10.1987	CA18S	B	21	1.5 dCi	02.2007 → 12.2013	K9K 282 D 7
2.0	01.1986 → 09.1988	CA20E	B	27	1.5 dCi	02.2007 → 12.2013	K9K 292 D 7
2.0	01.1986 → 09.1988	CA20S	B	27	1.5 dCi	07.2008 → 12.2013	K9K 282 D 7
2.0 4x4	01.1986 → 09.1988	CA20E	B	27	1.5 dCi	07.2008 → 12.2013	K9K 292 D 7
2.0 4x4	01.1986 → 09.1988	CA20S	B	27	1.5 dCi	01.2010 → 12.2013	K9K 430 D 7
2.0 4x4 (NM10)	06.1986 → 09.1988	CA20S	B	27	1.6	02.2007 → 12.2013	HR16DE AB 12
<b>PRAIRIE PRO (M11)</b>					1.6	02.2007 → 12.2013	HR16DE AB 12
2.0	03.1989 → 08.1990	CA20E	B	27	1.6	11.2010 → 12.2013	HR16DE AB 12
2.0	10.1989 → 03.1992	CA20S	B	27	1.6 LPG	11.2010 → 12.2013	HR16DE AB 12
2.0	09.1990 → 03.1992	CA20E	B	27	1.6 dCi	10.2011 → 12.2013	R9M D 18
2.0 4x4	03.1989 → 08.1990	CA20E	B	27	1.6 dCi All-wheel Drive	10.2011 → 12.2013	R9M D 18
2.0 4x4	10.1989 → 03.1992	CA20S	B	27	2.0 dCi	02.2007 → 12.2013	M1D D 26
2.0 4x4	09.1990 → 03.1992	CA20E	B	27	2.0 dCi	02.2007 → 12.2013	M9R D 26
2.0 i	10.1988 → 04.1992	CA20E	B	27	2.0 dCi All-wheel Drive	02.2007 → 12.2013	M1D D 26
2.0 i 4x4	10.1988 → 12.1992	CA20E	B	27	2.0 dCi All-wheel Drive	02.2007 → 12.2013	M9R D 26
<b>PRESAGE (U30)</b>					<b>QASHQAI II SUV (J11, J11_)</b>		
2.5 D (VU30)	03.1998 → 12.2003	YD25DDTi	D	39	1.2 DIG-T	11.2013 →	HRA2DDT B 4
2.5 D 4WD (VNU30)	03.1998 → 12.2003	YD25DDTi	D	39	1.5 dCi	11.2013 →	K9K 636 D 7
2.5 Di 16V	06.1998 → 08.2001	YD25DDTi	D	39	1.5 dCi	11.2013 →	K9K 646 D 7

				Pos					Pos
1.5 dCi	06.2018 →	K9K 872	D	7	1.7 D	09.1984 → 12.1986	CD17	D	16
1.6 dCi	11.2013 →	R9M	D	18	<b>SUNNY I Traveller (B11)</b>				
1.6 dCi ALL MODE 4x4-i	11.2013 →	R9M	D	18	1.7 D	03.1982 → 10.1986	CD17	D	16
<b>SANI Closed Off-Road Vehicle</b>					<b>SUNNY II (N13, B12)</b>				
2.5 dCi	01.2005 →	YD25DDTi	D	39	1.6 GTI 16V	02.1987 → 10.1988	CA16D	B	11
2.5 dCi 4x4	01.2005 →	YD25DDTi	D	39	1.7 D	06.1986 → 05.1989	CD17	D	16
<b>SENTRA Hatchback</b>					<b>SUNNY II Coupe (B12)</b>				
1.7 D	09.1984 → 12.1986	CD17	D	16	1.6 GTI 16V	05.1987 → 05.1989	CA16D	B	11
<b>SENTRA Saloon</b>					1.8 GTI 16V	01.1989 → 06.1991	CA18D	B	21
1.7 D	09.1984 → 12.1986	CD17	D	16	<b>SUNNY II Hatchback (N13)</b>				
<b>SENTRA V (B15)</b>					1.6 GTI 16V	06.1987 → 05.1989	CA16D	B	11
1.8	01.2000 → 08.2006	QG18DE	B	15	1.7 D	06.1986 → 01.1991	CD17	D	16
1.8	01.2000 → 08.2006	QG18DE	B	15	1.8 GTI 16V	01.1989 → 06.1991	CA18D	B	21
1.8	01.2000 → 09.2006	QG18DE	B	15	<b>SUNNY II Traveller (B12)</b>				
1.8	03.2002 → 08.2006	QG18DE	B	15	1.7 D	01.1986 → 06.1991	CD17	D	16
<b>SENTRA VII (B17)</b>					<b>SUNNY III (N14)</b>				
1.6	05.2013 →	HR16DE	AB	12	1.8	06.1990 → 12.1992	CA18DE	B	23
1.6	05.2013 →	HR16DE	AB	12	2.0 D	10.1990 → 05.1995	CD20	D	28
1.6	08.2014 →	HR16DE	AB	12	<b>SUNNY III Hatchback (N14)</b>				
<b>SERENA (C23)</b>					2.0 D	10.1990 → 05.1995	CD20	D	28
2.0 D (KVJC23)	06.1991 → 09.2001	CD20	D	28	<b>SUNNY III Liftback (N14)</b>				
2.0 TD (KVC23)	09.1996 → 09.1996	CD20T	D	28	2.0 D	10.1990 → 05.1995	CD20	D	28
2.0 TD 4WD (KVNC23)	06.1991 → 09.1996	CD20T	D	28	<b>SUNNY III Traveller (Y10)</b>				
2.0 TDI (KVC23)	09.1996 → 06.1999	CD20ET	D	29	2.0 D	06.1991 → 03.2000	CD20	D	28
2.0 TDI 4WD (KVNC23)	09.1996 → 06.1999	CD20ET	D	29	<b>SUNNY IV Coupe</b>				
<b>SERENA (C24)</b>					1.8	04.2000 → 09.2003	QG18DE	B	15
2.5 DCi SGX	06.1999 → 09.2005	YD25DDTi	D	39	<b>SUNNY IV Hatchback</b>				
2.5 DCi SGX 4x4	06.1999 → 09.2005	YD25DDTi	D	39	1.8	04.2000 → 09.2003	QG18DE	B	15
<b>SERENA (C27)</b>					<b>SUNNY IV Saloon (N16)</b>				
1.2 Combined e-Power	03.2018 →	HR12DE	BG	10	1.8	04.2000 → 09.2003	QG18DE	B	15
1.2 e-Power	03.2018 →	HR12DE	BG	10	<b>TERRA (JD23TT, JD23F)</b>				
<b>SILVIA (S12)</b>					2.5 TDCI	08.2018 →	YD25DDTi	D	39
1.8	06.1984 → 12.1988	CA18ET	B	21	2.5 TDCI	08.2018 →	YD25DDTi	D	39
1.8 Turbo R	08.1983 → 04.1988	CA18ET	B	21	2.5 TDCI 4WD	08.2018 →	YD25DDTi	D	39
2.0	09.1984 → 12.1988	CA20E	B	27	<b>TIIDA Hatchback (C11)</b>				
2.0 GP	01.1984 → 12.1988	CA20E	B	27	1.5 dCi	09.2007 → 12.2011	K9K 278	D	7
2.0i	10.1983 → 06.1988	CA20E	B	27	1.6	08.2005 → 06.2013	HR16DE	AB	12
<b>SILVIA Coupe (S13)</b>					1.6	09.2007 → 12.2011	HR16DE	AB	12
1.8	08.1988 → 03.1994	CA18D	B	21	1.6 Flexfuel	06.2006 → 06.2013	HR16DE	AB	12
1.8i 16V	06.1988 → 11.1993	CA18DE	B	23	<b>TIIDA Hatchback (C12)</b>				
<b>SILVIA Hatchback (S12)</b>					1.6	08.2012 →	HR16DE	AB	12
2.0	06.1983 → 12.1986	CA20E	B	27	1.6 CVTC	08.2012 →	HR16DE	AB	12
2.0	09.1986 → 12.1988	CA20E	B	27	1.6 CVTC	01.2014 →	HR16DE	AB	12
<b>SKYLINE (R31)</b>					<b>TIIDA Saloon (SC11)</b>				
1.8	07.1986 → 03.1989	CA18S	B	21	1.5 dCi	01.2007 → 12.2012	K9K 278	D	7
2.0	09.1985 → 04.1989	CA20S	B	27	1.5 dCi	09.2007 → 12.2012	K9K 278	D	7
<b>SKYLINE (R32)</b>					1.6	05.2006 → 06.2013	HR16DE	AB	12
1.8	03.1989 → 06.1993	CA18i	B	21	1.6 (C11L)	09.2007 → 12.2012	HR16DE	AB	12
<b>STANZA (T11)</b>					1.6 Flexfuel	05.2006 → 06.2013	HR16DE	AB	12
1.6	08.1981 → 12.1985	CA16S	B	11	<b>TIIDA Saloon (SC12)</b>				
1.8 SGL	03.1983 → 12.1985	CA18S	B	21	1.6	09.2012 → 09.2016	HR16DE	AB	12
2.0	09.1982 → 12.1983	CA20S	B	27	1.6	09.2016 →	HR16DE	AB	12
2.0	09.1983 → 12.1985	CA20E	B	27	<b>VERSA I</b>				
<b>STANZA Hatchback (T11)</b>					1.6	09.2008 → 06.2013	HR16DE	AB	12
1.6	08.1981 → 12.1985	CA16S	B	11	1.6i 16V	01.2006 →	HR16DE	AB	12
1.8	08.1981 → 12.1985	CA18S	B	21	<b>VERSA II (N17_)</b>				
1.8	08.1981 → 12.1985	CA18S	B	21	1.6	08.2011 →	HR16DE	AB	12
2.0	08.1981 → 12.1983	CA20S	B	27	1.6	08.2011 →	HR16DE	AB	12
2.0	04.1983 → 12.1985	CA20E	B	27	1.6 Flex	10.2011 →	HR16DE	AB	12
2.0	04.1983 → 12.1985	CA20S	B	27	<b>WINGROAD / AD Wagon (_Y10)</b>				
<b>STANZA Hatchback (T12)</b>					1.7 D	10.1990 → 04.1999	CD17	D	16
2.0	09.1986 → 12.1989	CA20E	B	27	2.0 D (WEY10)	04.1994 → 08.1998	CD20	D	28
2.0 4WD	09.1986 → 12.1988	CA20E	B	27	<b>WINGROAD / AD Wagon (_Y11)</b>				
<b>STANZA Saloon (T12)</b>					1.7 D	05.1999 → 08.2004	CD17	D	16
2.0	09.1985 → 12.1989	CA20E	B	27	1.8	05.1999 → 08.2004	QG18DE	B	15
<b>SUNNY I (B11)</b>					1.8 All-wheel Drive	10.2003 → 11.2005	QG18DE	B	15
1.7 D	03.1982 → 10.1986	CD17	D	16	<b>X-TRAIL (T30)</b>				
1.7 D	03.1982 → 12.1987	CD17	D	16	2.2 DCi	10.2004 → 01.2013	YD22DDTi	D	36
<b>SUNNY I Coupe (B11)</b>					2.2 DCi	10.2004 → 01.2013	YD22ETI	D	37

N







		Pos			Pos
2.2 DCi FWD 06.2001 → 09.2004	YD22ETI D	37	1.5 dCi 08.2003 → 10.2009	K9K 710 D	6
2.2 Di 4x4 07.2001 → 10.2005	YD22DDTi D	36	1.5 dCi 08.2003 → 10.2009	K9K 714 D	6
2.2 Di 4x4 07.2001 → 10.2005	YD22ETI D	37	1.5 dCi 08.2003 → 10.2009	K9K 722 D	6
2.2 dCi 12.2003 → 01.2013	YD22DDTi D	36	1.5 dCi 08.2003 →	K9K 704 D	6
2.2 dCi 12.2003 → 01.2013	YD22ETI D	37	1.5 dCi 08.2005 → 10.2009	K9K 710 D	6
2.2 dCi 4x4 06.2001 → 12.2008	YD22DDTi D	36	1.5 dCi 08.2005 → 10.2009	K9K 714 D	6
2.2 dCi 4x4 06.2001 → 12.2008	YD22ETI D	37	1.5 dCi 70 09.2005 → 10.2009	K9K 700 D	6
<b>X-TRAIL (T31)</b>			1.5 dCi 70 09.2005 → 10.2009	K9K 716 D	7
2.0 dCi 06.2007 → 11.2013	M9R D	26	1.6 16V 08.2003 → 10.2009	K4M 752 B	13
2.0 dCi 4x4 06.2007 → 11.2013	M9R D	26	dCi 85 04.2006 → 10.2009	K9K 276 D	7
2.0 dCi 4x4 06.2007 → 11.2013	M9R 760 D	26	dCi 85 04.2006 → 10.2009	K9K 718 D	8
2.0 dCi 4x4 10.2009 → 11.2013	M9R 760 D	26	<b>MURANO II VAN (Z51)</b>		
<b>X-TRAIL (T32R)</b>			2.5 dCi 4x4 03.2013 → 09.2014	YD25DDTi D	39
1.6 dCi 12.2014 →	R9M D	18	<b>NAVARA Platform/Chassis (D22)</b>		
<b>X-TRAIL (T32RR)</b>			2.5 Di 02.2002 →	YD25DDTi D	39
1.6 dCi ALL MODE 4x4-i 04.2016 →	R9M D	18	2.5 Di 02.2002 →	YD25ETI D	40
<b>X-TRAIL (T32 )</b>			2.5 Di 06.2014 →	YD25DDTi D	39
1.6 dCi (T32) 04.2014 →	R9M D	18	2.5 Di 4WD 02.2002 →	YD25DDTi D	39
1.6 dCi ALL MODE 4x4-i 04.2014 →	R9M D	18	2.5 Di 4WD 06.2014 →	YD25DDTi D	39
(NT32)			<b>NAVARA Platform/Chassis (D23)</b>		
2.0 dCi (T32) 10.2016 →	M9R D	26	2.5 DDTi 01.2015 →	YD25DDTi D	39
2.0 dCi ALL MODE 4x4-i 10.2016 →	M9R D	26	2.5 dCi 11.2017 →	YD25DDTi D	39
(NT32)			<b>NOTE VAN (E11)</b>		
			1.5 dCi 01.2011 → 09.2012	K9K 276 D	7
<b>AD Van (VB11)</b>			<b>NP300 NAVARA Platform/Chassis (D40)</b>		
1.7 D 10.1984 → 08.1990	CD17 D	16	2.5 dCi 08.2008 → 12.2015	YD25DDTi D	39
<b>AD Van (Y10)</b>			2.5 dCi 03.2010 →	YD25DDTi D	39
2.0 D 10.1994 → 04.1999	CD20 D	28	2.5 dCi 4WD 08.2008 →	YD25DDTi D	39
<b>AD Van (Y11)</b>			2.5 dCi 4WD 08.2008 →	YD25DDTi D	39
1.7 D 05.1999 → 12.2008	CD17 D	16	<b>NT400 CABSTAR (F24M)</b>		
<b>AD Van (Y12)</b>			35.14, 45.14 01.2014 →	YD25K3LD-5MI D	42
1.6 4WD 12.2008 →	HR16DE AB	12	<b>NV200 / EVALIA Bus</b>		
<b>CABSTAR (F24M, F24W)</b>			1.5 dCi 110 (M20, M20M) 04.2011 →	K9K 636 D	7
28.11 DCI, 32.11 DCI, 09.2006 → 12.2013	YD25DDTi D	39	1.5 dCi 110 (M20, M20M) 04.2011 →	K9K 646 D	7
35.11 DCI 2.5 (F24M)			1.5 dCi 85 (M20, M20M, 07.2010 →	K9K 400 D	7
28.12 DCI, 32.12 DCI, 09.2006 → 12.2013	YD25DDTi D	39	M20K, M20KK)		
34.12 DCI, 35.12 DCI 2.5 (F24M)			1.5 dCi 85 (M20, M20M, 07.2010 →	K9K 608 D	7
34.110 DCI 2.5 (F24M) 01.2007 → 04.2012	YD25DDTi D	39	M20K, M20KK)		
35.13 DCI, 45.13 DCI 2.5 (F24M) 09.2006 → 12.2012	YD25DDTi D	39	1.5 dCi 85 (M20, M20M, 07.2010 →	K9K 628 D	7
35.14 DCI, 45.14 DCI 2.5 (F24M) 09.2006 → 12.2013	YD25DDTi D	39	M20K, M20KK)		
35.14 DCI, 45.14 DCI 2.5 (F24M) 09.2006 → 12.2013	YD25DDTi D	39	1.5 dCi 90 (M20, M20M) 04.2011 →	K9K 892 D	8
35.14 DCI, 45.14 DCI 2.5 (F24M) 09.2006 → 12.2013	YD25K3LD-5MI D	42	1.6 16V (M20, M20M) 07.2010 →	HR16DE AB	12
<b>INTERSTAR Bus (X70)</b>			<b>NV200 Van</b>		
dCi 90 07.2002 → 08.2006	G9T 722 D	38	1.5 dCi 110 (M20, M20M) 04.2011 →	K9K 636 D	7
dCi 100 11.2003 → 03.2006	G9U 720 D	41	1.5 dCi 110 (M20, M20M) 04.2011 →	K9K 646 D	7
dCi 100 04.2006 → 03.2011	G9U 650 D	41	1.5 dCi 85 (M20, M20M) 02.2010 →	K9K 400 D	7
dCi 115 07.2002 → 08.2006	G9U 720 D	41	1.5 dCi 85 (M20, M20M) 02.2010 →	K9K 608 D	7
dCi 120 09.2006 → 03.2011	G9U 650 D	41	1.5 dCi 85 (M20, M20M) 02.2010 →	K9K 628 D	7
dCi 80 04.2002 → 08.2006	F9Q 772 D	17	1.5 dCi 90 (M20, M20M) 04.2011 →	K9K 892 D	8
<b>INTERSTAR Platform/Chassis</b>			1.6 16V (M20, M20M) 02.2010 →	HR16DE AB	12
dCi 100 02.2004 →	G9U 720 D	41	<b>NV250 Bus (X61)</b>		
dCi 115 08.2003 →	G9U 720 D	41	dCi 115 07.2019 →	K9K 872 D	7
dCi 120 08.2006 →	G9U 650 D	41	dCi 80 07.2019 →	K9K 872 D	7
<b>INTERSTAR Van (X70)</b>			dCi 95 07.2019 →	K9K 872 D	7
dCi 90 07.2002 →	G9T 722 D	38	<b>NV250 Van (X61)</b>		
dCi 100 11.2003 → 03.2006	G9U 720 D	41	dCi 115 07.2019 →	K9K 872 D	7
dCi 100 04.2006 →	G9U 720 D	41	dCi 80 07.2019 →	K9K 872 D	7
dCi 115 04.2002 →	G9U 720 D	41	dCi 95 07.2019 →	K9K 872 D	7
dCi 120 09.2006 →	G9U 650 D	41	<b>NV300 Kombi (X82)</b>		
dCi 80 04.2002 → 08.2006	F9Q 772 D	17	1.6 dCi 125 09.2016 →	R9M 452 D	18
<b>JUKE Van (F15)</b>			1.6 dCi 145 09.2016 →	R9M 452 D	18
CVTC 03.2013 →	HR16DE AB	12	1.6 dci 120 09.2016 →	R9M 413 D	18
dCi 06.2010 →	K9K 636 D	7	1.6 dci 95 09.2016 →	R9M 413 D	18
<b>KUBISTAR Van (X76)</b>			<b>NV300 Platform/Chassis (X82)</b>		
1.2 08.2003 →	D7F 764 B	1	1.6 dci 125 09.2016 →	R9M 452 D	18
1.2 16V 04.2006 →	D4F 712 B	2	1.6 dci 145 09.2016 →	R9M 452 D	18



					Pos						Pos		
<b>NV300 Van (X82)</b>						dCi 125 RWD	11.2011 → 09.2016	M9T 692	D	<b>32</b>			
1.6 dCi 120	09.2016 →	R9M 413	D	<b>18</b>	dCi 125 RWD	11.2011 → 09.2016	M9T 696	D	<b>32</b>				
1.6 dCi 125	09.2016 →	R9M 452	D	<b>18</b>	dCi 125 RWD	11.2011 → 09.2016	M9T 698	D	<b>32</b>				
1.6 dCi 145	09.2016 →	R9M 452	D	<b>18</b>	dCi 125 RWD	11.2011 → 09.2016	M9T 870	D	<b>32</b>				
1.6 dCi 95	09.2016 →	R9M 413	D	<b>18</b>	dCi 125 RWD	11.2011 → 09.2016	M9T 896	D	<b>32</b>				
<b>NV350 / CARAVAN Bus (E26)</b>						dCi 135	06.2014 → 09.2016	M9T 702	D	<b>32</b>			
2.5 dCi	05.2012 →	YD25DDTi	D	<b>39</b>	dCi 145	11.2011 → 02.2014	M9T 678	D	<b>32</b>				
2.5 dCi	09.2013 →	YD25DDTi	D	<b>39</b>	dCi 145	11.2011 → 02.2014	M9T 680	D	<b>32</b>				
2.5 dCi 4WD	05.2012 →	YD25DDTi	D	<b>39</b>	dCi 145	11.2011 → 02.2014	M9T 706	D	<b>32</b>				
<b>NV350 Van (E26)</b>						dCi 145 RWD	11.2011 → 02.2014	M9T 694	D	<b>32</b>			
2.5 dCi	06.2012 →	YD25DDTi	D	<b>39</b>	dCi 145 RWD	11.2011 → 02.2014	M9T 696	D	<b>32</b>				
2.5 dCi 4WD	06.2012 →	YD25DDTi	D	<b>39</b>	dCi 145 RWD	11.2011 → 02.2014	M9T 698	D	<b>32</b>				
<b>NV400 Bus (X62, X62B)</b>						dCi 150	02.2014 → 09.2016	M9T 880	D	<b>32</b>			
dCi 100	11.2011 → 06.2014	M9T 670	D	<b>32</b>	dCi 150 RWD	02.2014 → 09.2016	M9T 880	D	<b>32</b>				
dCi 100	11.2011 → 06.2014	M9T 672	D	<b>32</b>	dCi 165	06.2014 → 09.2016	M9T 702	D	<b>32</b>				
dCi 100	11.2011 → 06.2014	M9T 676	D	<b>32</b>	dCi 170	09.2016 →	M9T 706	D	<b>32</b>				
dCi 110	06.2014 → 09.2016	M9T 870	D	<b>32</b>	<b>PATHFINDER III VAN (R51 )</b>								
dCi 125	11.2011 → 09.2016	M9T 670	D	<b>32</b>	2.5 dCi 4x4 (R51M)	03.2013 → 08.2014	YD25DDTi	D	<b>39</b>				
dCi 125	11.2011 → 09.2016	M9T 672	D	<b>32</b>	<b>PATROL GR IV Platform/Chassis (Y60)</b>								
dCi 125	11.2011 → 09.2016	M9T 676	D	<b>32</b>	2.8 TD 4x4	01.1994 → 12.1997	RD28T	D	<b>31</b>				
dCi 125	11.2011 → 09.2016	M9T 680	D	<b>32</b>	<b>PICK UP (D22G)</b>								
dCi 125	11.2011 → 09.2016	M9T 870	D	<b>32</b>	2.5 dCi	01.2016 →	YD25DDTi	D	<b>39</b>				
dCi 135	06.2014 → 09.2016	M9T 702	D	<b>32</b>	<b>PRIMASTAR Bus (X83)</b>								
dCi 145	11.2011 → 02.2014	M9T 678	D	<b>32</b>	2.0	03.2001 → 08.2006	F4R 720	B	<b>19</b>				
dCi 145	11.2011 → 02.2014	M9T 680	D	<b>32</b>	2.0	03.2001 → 08.2006	F4R 722	B	<b>19</b>				
dCi 145	11.2011 → 02.2014	M9T 706	D	<b>32</b>	2.0	04.2006 →	F4R 820	B	<b>20</b>				
dCi 150	02.2014 → 09.2016	M9T 880	D	<b>32</b>	dCi 100	03.2001 →	F9Q 760	D	<b>17</b>				
dCi 160	06.2014 → 09.2016	M9T 702	D	<b>32</b>	dCi 120	09.2006 →	M9R 630	D	<b>24</b>				
dCi 170	07.2015 →	M9T 706	D	<b>32</b>	dCi 120	09.2006 →	M9R 780	D	<b>25</b>				
<b>NV400 Platform/Chassis (X62, X62B)</b>						dCi 140	07.2003 →	G9U 730	D	<b>41</b>			
dCi 100	11.2011 → 06.2014	M9T 670	D	<b>32</b>	dCi 80	03.2001 →	F9Q 762	D	<b>17</b>				
dCi 100	11.2011 → 06.2014	M9T 672	D	<b>32</b>	dCi 90	09.2006 →	M9R 630	D	<b>24</b>				
dCi 100	11.2011 → 06.2014	M9T 676	D	<b>32</b>	dCi 90	09.2006 →	M9R 782	D	<b>25</b>				
dCi 110	06.2014 → 06.2016	M9T 870	D	<b>32</b>	<b>PRIMASTAR Platform/Chassis (X83)</b>								
dCi 125	11.2011 → 06.2016	M9T 670	D	<b>32</b>	1.9 dCi 100	07.2002 → 08.2006	F9Q 760	D	<b>17</b>				
dCi 125	11.2011 → 06.2016	M9T 672	D	<b>32</b>	1.9 dCi 80	07.2002 → 08.2006	F9Q 762	D	<b>17</b>				
dCi 125	11.2011 → 06.2016	M9T 676	D	<b>32</b>	2.0	07.2002 → 08.2006	F4R 720	B	<b>19</b>				
dCi 125	11.2011 → 06.2016	M9T 680	D	<b>32</b>	2.5 dCi 140	07.2002 → 08.2006	G9U 730	D	<b>41</b>				
dCi 125 RWD	11.2011 → 06.2016	M9T 686	D	<b>32</b>	<b>PRIMASTAR Van (X83)</b>								
dCi 125 RWD	11.2011 → 06.2016	M9T 690	D	<b>32</b>	1.9 dCi 100	09.2002 →	F9Q 760	D	<b>17</b>				
dCi 125 RWD	11.2011 → 06.2016	M9T 692	D	<b>32</b>	1.9 dCi 80	09.2002 →	F9Q 762	D	<b>17</b>				
dCi 125 RWD	11.2011 → 06.2016	M9T 696	D	<b>32</b>	2.0	02.2003 →	F4R 720	B	<b>19</b>				
dCi 125 RWD	11.2011 → 06.2016	M9T 698	D	<b>32</b>	2.0	04.2006 →	F4R 820	B	<b>20</b>				
dCi 125 RWD	11.2011 → 06.2016	M9T 870	D	<b>32</b>	2.0 dCi 115	09.2006 →	M9R 630	D	<b>24</b>				
dCi 125 RWD	11.2011 → 06.2016	M9T 896	D	<b>32</b>	2.0 dCi 115	09.2006 →	M9R 780	D	<b>25</b>				
dCi 135	06.2014 → 06.2016	M9T 702	D	<b>32</b>	2.0 dCi 90	09.2006 →	M9R 630	D	<b>24</b>				
dCi 135 RWD	06.2014 → 06.2016	M9T 696	D	<b>32</b>	2.0 dCi 90	09.2006 →	M9R 782	D	<b>25</b>				
dCi 135 RWD	06.2014 → 06.2016	M9T 698	D	<b>32</b>	2.5 dCi 140	07.2003 →	G9U 730	D	<b>41</b>				
dCi 145	11.2011 → 06.2016	M9T 678	D	<b>32</b>	<b>QASHQAI / QASHQAI +2 I VAN (J10, JJ10E)</b>								
dCi 145	11.2011 → 06.2016	M9T 680	D	<b>32</b>	1.6 CVTC	03.2013 → 04.2014	HR16DE	AB	<b>12</b>				
dCi 145	11.2011 → 06.2016	M9T 706	D	<b>32</b>	1.6 dCi	03.2013 → 04.2014	R9M	D	<b>18</b>				
dCi 145 RWD	11.2011 → 06.2016	M9T 694	D	<b>32</b>	1.6 dCi All-wheel Drive	03.2013 → 04.2014	R9M	D	<b>18</b>				
dCi 145 RWD	11.2011 → 06.2016	M9T 696	D	<b>32</b>	2.0 dCi All-wheel Drive	03.2013 → 04.2014	M9R	D	<b>26</b>				
dCi 145 RWD	11.2011 → 06.2016	M9T 698	D	<b>32</b>	<b>QASHQAI II VAN (J11 )</b>								
dCi 150	08.2014 → 06.2016	M9T 880	D	<b>32</b>	1.5 dCi	05.2015 →	K9K 646	D	<b>7</b>				
dCi 150 RWD	08.2014 → 06.2016	M9T 880	D	<b>32</b>	1.5 dCi	06.2018 →	K9K 872	D	<b>7</b>				
dCi 165	06.2014 → 06.2016	M9T 702	D	<b>32</b>	<b>SUNNY III Estate Van (Y10)</b>								
dCi 170	06.2016 →	M9T 706	D	<b>32</b>	1.7 D	11.1990 → 03.2000	CD17	D	<b>16</b>				
<b>NV400 Van (X62, X62B)</b>						<b>X-TRAIL VAN (T31)</b>							
dCi 100	11.2011 → 05.2014	M9T 670	D	<b>32</b>	dCi	01.2011 → 02.2014	M9R	D	<b>26</b>				
dCi 100	11.2011 → 05.2014	M9T 672	D	<b>32</b>	dCi 4x4	01.2013 → 02.2014	M9R	D	<b>26</b>				
dCi 100	11.2011 → 05.2014	M9T 676	D	<b>32</b>	dCi 4x4	03.2013 → 02.2014	M9R 760	D	<b>26</b>				
dCi 110	06.2014 →	M9T 870	D	<b>32</b>	<b>X-TRAIL VAN (T32)</b>								
dCi 125	11.2011 → 09.2016	M9T 670	D	<b>32</b>	dCi	04.2014 →	R9M	D	<b>18</b>				
dCi 125	11.2011 → 09.2016	M9T 672	D	<b>32</b>	dCi 4x4	04.2014 →	R9M	D	<b>18</b>				
dCi 125	11.2011 → 09.2016	M9T 676	D	<b>32</b>									
dCi 125	11.2011 → 09.2016	M9T 680	D	<b>32</b>	<b>ATLEON</b>								
dCi 125 RWD	11.2011 → 09.2016	M9T 686	D	<b>32</b>	6.7 dCi	11.2006 →	ISB4-6H	D	<b>44</b>				
dCi 125 RWD	11.2011 → 09.2016	M9T 690	D	<b>32</b>									

N

				Pos				Pos
6.7 dCi	11.2006 →	ISB4-6L	D	44				
80.19	11.2006 →	ISB4-4H	D	44				
80.19	11.2006 →	ISB4-4L	D	44				

N

					Reference	Item No.		
<b>1</b>		<b>69</b>						
<b>D7F 764</b>	08.2003 →	B (NA)	4	1149 cm <sup>3</sup>	2V	44 kW (60 PS)	9,6	76,80 mm
	IN [2] EX [2]	32,8 x 6 x 106,7 29,9 x 6 x 106,7	S - - A/S - -	- 30° - - - 45° - -	1 - III 1 - III			<b>511019</b> <b>511020</b>
	IN/EX [4]	11,07 x 6 x 45,0	B1					<b>81-5132</b>
<b>2</b>		<b>69</b>						
<b>D4F 712</b>	04.2006 →	B (NA)	4	1149 cm <sup>3</sup>	4V	55 kW (75 PS)	9,8	76,80 mm
	IN [2] EX [2]	26,0 x 5,5 x 110,8 22,1 x 5,5 x 112,5	S - - RA/S- -	- 45° - - - 45° - -	22 - III 22 - III	13201-00QAJ 13202-00QAK		<b>539028</b> <b>539029</b>
	[50]	∅ 5,5 mm						<b>MK-5.5H</b>
	IN/EX [4]	11,07 x 5.5 x 40,6	B1					<b>81-5136</b> (1)
	(1) ohne Ventilschaftabdichtung/without valve stem gasket/sans joint de tige de soupape/sin junta de vástago de válvula/без уплотнения стержня клапана							
<b>3</b>		<b>72</b>						
<b>HRA2DDT Euro 6</b>		B (LA)	4	1198 cm <sup>3</sup>	4V	85-88 kW (116-120 PS)	10,0:1	73,20 mm
	[4]	M 30 x 28				13231-00Q0A		<b>50 007 814</b>
	[4]	M 30 x 28				13231-00Q0B		<b>50 007 815</b>
	[4]	M 30 x 28				13231-00Q0C		<b>50 007 816</b>
	[4]	M 30 x 28				13231-00Q0D		<b>50 007 818</b>
	[4]	M 30 x 28				13231-00Q0E		<b>50 007 819</b>
	[4]	M 30 x 28				13231-00Q0F		<b>50 007 820</b>
	[4]	M 30 x 28				13231-00Q0G		<b>50 007 821</b>
	[4]	M 30 x 28				13231-00Q0H		<b>50 007 822</b>
	[4]	M 30 x 28				13231-00Q0J		<b>50 007 823</b>
	[4]	M 30 x 28				13231-00Q0K		<b>50 007 824</b>
	[4]	M 30 x 28				13231-00Q0L		<b>50 007 825</b>
	[4]	M 30 x 28				13231-00Q0M		<b>50 007 826</b>
	[4]	M 30 x 28				13231-00Q1A		<b>50 007 827</b>
	[4]	M 30 x 28				13231-00Q1B		<b>50 007 828</b>
	[4]	M 30 x 28				13231-00Q1C		<b>50 007 830</b>
	[4]	M 30 x 28				13231-00Q1D		<b>50 007 831</b>
	[4]	M 30 x 28				13231-00Q1E		<b>50 007 832</b>
	[4]	M 30 x 28				13231-00Q1F		<b>50 007 833</b>
	[4]	M 30 x 28				13231-00Q1G		<b>50 007 834</b>
	[4]	M 30 x 28				13231-00Q1H		<b>50 007 835</b>
	[4]	M 30 x 28				13231-00Q1J		<b>50 007 836</b>
	[4]	M 30 x 28				13231-00Q1K		<b>50 007 838</b>
	[4]	M 30 x 28				13231-00Q1L		<b>50 007 839</b>
	[4]	M 30 x 28				13231-00Q1M		<b>50 007 840</b>
	[4]	M 30 x 28				13231-00Q2A		<b>50 007 841</b>
	[4]	M 30 x 28				13231-00Q2B		<b>50 007 842</b>
	[4]	M 30 x 28				13231-00Q2C		<b>50 007 843</b>
	[4]	M 30 x 28				13231-00Q2D		<b>50 007 844</b>
	[4]	M 30 x 28				13231-00Q2E		<b>50 007 845</b>
	[4]	M 30 x 28				13231-00Q2F		<b>50 007 846</b>
	[4]	M 30 x 28				13231-00Q2G		<b>50 007 847</b>
<b>4</b>		<b>72,2</b>						
<b>HRA2DDT</b>	11.2013 →	B (A)	4	1197 cm <sup>3</sup>	4V	85 kW (116 PS)	10	73,10 mm
Fortsetzung nächste Seite / continued on next page / suite page suivante / continuación página próxima / Продолжение на следующей странице								

N

					Reference	Item No.	
	[4]	M	30 x 28			13231-00Q0A	50 007 814
	[4]	M	30 x 28			13231-00Q0B	50 007 815
	[4]	M	30 x 28			13231-00Q0C	50 007 816
	[4]	M	30 x 28			13231-00Q0D	50 007 818
	[4]	M	30 x 28			13231-00Q0E	50 007 819
	[4]	M	30 x 28			13231-00Q0F	50 007 820
	[4]	M	30 x 28			13231-00Q0G	50 007 821
	[4]	M	30 x 28			13231-00Q0H	50 007 822
	[4]	M	30 x 28			13231-00Q0J	50 007 823
	[4]	M	30 x 28			13231-00Q0K	50 007 824
	[4]	M	30 x 28			13231-00Q0L	50 007 825
	[4]	M	30 x 28			13231-00Q0M	50 007 826
	[4]	M	30 x 28			13231-00Q1A	50 007 827
	[4]	M	30 x 28			13231-00Q1B	50 007 828
	[4]	M	30 x 28			13231-00Q1C	50 007 830
	[4]	M	30 x 28			13231-00Q1D	50 007 831
	[4]	M	30 x 28			13231-00Q1E	50 007 832
	[4]	M	30 x 28			13231-00Q1F	50 007 833
	[4]	M	30 x 28			13231-00Q1G	50 007 834
	[4]	M	30 x 28			13231-00Q1H	50 007 835
	[4]	M	30 x 28			13231-00Q1J	50 007 836
	[4]	M	30 x 28			13231-00Q1K	50 007 838
	[4]	M	30 x 28			13231-00Q1L	50 007 839
	[4]	M	30 x 28			13231-00Q1M	50 007 840
	[4]	M	30 x 28			13231-00Q2A	50 007 841
	[4]	M	30 x 28			13231-00Q2B	50 007 842
	[4]	M	30 x 28			13231-00Q2C	50 007 843
	[4]	M	30 x 28			13231-00Q2D	50 007 844
	[4]	M	30 x 28			13231-00Q2E	50 007 845
	[4]	M	30 x 28			13231-00Q2F	50 007 846
	[4]	M	30 x 28			13231-00Q2G	50 007 847

N

<b>5</b>		<b>72,2</b>					
<b>H4B 408</b>	12.2016 →	B (A) 3	898 cm <sup>3</sup> 4V	66 kW	(90 PS) 9,5	73,10 mm	
	IN [2] EX [2]	26,6 x 5,5 x 100,8 23,5 x 5,5 x 101,7	S - Ni - RA/S- -	- 45° - - - 30° - -	22 - III 22 - III	<b>539048</b> <small>NEW</small> <b>539052</b> <small>NEW</small>	
	[50]	Ø 5,5 mm				<b>MK-5.5H</b>	

Fortsetzung nächste Seite / continued on next page / suite page suivante / continuación página próxima / Продолжение на следующей странице

					Reference	Item No.
	[4]	M 30 x 28			13231-00Q0A	50 007 814
	[4]	M 30 x 28			13231-00Q0B	50 007 815
	[4]	M 30 x 28			13231-00Q0C	50 007 816
	[4]	M 30 x 28			13231-00Q0D	50 007 818
	[4]	M 30 x 28			13231-00Q0E	50 007 819
	[4]	M 30 x 28			13231-00Q0F	50 007 820
	[4]	M 30 x 28			13231-00Q0G	50 007 821
	[4]	M 30 x 28			13231-00Q0H	50 007 822
	[4]	M 30 x 28			13231-00Q0J	50 007 823
	[4]	M 30 x 28			13231-00Q0K	50 007 824
	[4]	M 30 x 28			13231-00Q0L	50 007 825
	[4]	M 30 x 28			13231-00Q0M	50 007 826
	[4]	M 30 x 28			13231-00Q1A	50 007 827
	[4]	M 30 x 28			13231-00Q1B	50 007 828
	[4]	M 30 x 28			13231-00Q1C	50 007 830
	[4]	M 30 x 28			13231-00Q1D	50 007 831
	[4]	M 30 x 28			13231-00Q1E	50 007 832
	[4]	M 30 x 28			13231-00Q1F	50 007 833
	[4]	M 30 x 28			13231-00Q1G	50 007 834
	[4]	M 30 x 28			13231-00Q1H	50 007 835
	[4]	M 30 x 28			13231-00Q1J	50 007 836
	[4]	M 30 x 28			13231-00Q1K	50 007 838
	[4]	M 30 x 28			13231-00Q1L	50 007 839
	[4]	M 30 x 28			13231-00Q1M	50 007 840
	[4]	M 30 x 28			13231-00Q2A	50 007 841
	[4]	M 30 x 28			13231-00Q2B	50 007 842
	[4]	M 30 x 28			13231-00Q2C	50 007 843
	[4]	M 30 x 28			13231-00Q2D	50 007 844
	[4]	M 30 x 28			13231-00Q2E	50 007 845
	[4]	M 30 x 28			13231-00Q2F	50 007 846
	[4]	M 30 x 28			13231-00Q2G	50 007 847

N

6		76								
<b>K9K 700</b>		02.2003 →	D (A)	4	1461 cm <sup>3</sup>	2V	47-50 kW	(64-68 PS)	18,8	80,50 mm
<b>K9K 704</b>		01.2003 →	D (A)	4	1461 cm <sup>3</sup>	2V	47-48 kW	(64-65 PS)	18,8	80,50 mm
<b>K9K 710</b>		08.2003 → 10.2009	D (A)	4	1461 cm <sup>3</sup>	2V	42-45 kW	(57-61 PS)	18,8	80,50 mm
<b>K9K 714</b>		08.2003 → 10.2009	D (A)	4	1461 cm <sup>3</sup>	2V	42-45 kW	(57-61 PS)	18,8	80,50 mm
<b>K9K 722</b>		01.2003 → 06.2010	D (A)	4	1461 cm <sup>3</sup>	2V	60 kW	(82 PS)	18,8	80,50 mm

40 190 6..., 40 465 6..

	IN [2]	33,4 x 6 x 101,0	S - -	- 45° - -	22 - III	13201-00QAN 13201-BN700	<b>539018</b>	
	EX [2]	28,9 x 6 x 100,8	RA/S- -	- 45° - -	22 - III	13202-00QAP 13202-BN700	<b>539017</b>	
	[50]	Ø 6 mm					<b>MK-6H</b>	
	IN/EX [4]	11,05 x 6 x 40,5	B1				<b>81-51000</b>	
	IN/EX [4]	11,25/8.8 x 6 x 40,5	B1				<b>81-51001</b>	
						13001-00Q0T	<b>50 006 314</b> (2) <b>50 007 076</b> (2) <b>50 007 017</b> (1)	
	(1)	Schalenhartguss/chilled cast iron/pièce moulée trempée en surface/fundición en coquilla/Отливка с отбелсным поверхностным слоем / (ST)						
	(2)	(ST)						

Fortsetzung nächste Seite / continued on next page / suite page suivante / continuación página próxima / Продолжение на следующей странице

					Reference	Item No.
	[8]	M	35 x 30 x 33 x 7,55			<b>50 007 540</b>
	[8]	M	35 x 30 x 33 x 7,6			<b>50 007 541</b>
	[8]	M	35 x 30 x 33 x 7,65			<b>50 007 542</b>
	[8]	M	35 x 30 x 33 x 7,7			<b>50 007 543</b>
	[8]	M	35 x 30 x 33 x 7,75			<b>50 007 544</b>
	[8]	M	35 x 30 x 33 x 7,8			<b>50 007 545</b>
	[8]	M	35 x 30 x 33 x 7,85			<b>50 007 546</b>
	[8]	M	35 x 30 x 33 x 7,9			<b>50 007 547</b>
	[8]	M	35 x 30 x 33 x 7,95			<b>50 007 548</b>
	[8]	M	35 x 30 x 33 x 8			<b>50 007 549</b>

## 7

<b>K9K 270</b>		D (LA)	4	1461 cm <sup>3</sup>	4V	63 kW	(86 PS)	18,8:1	80,50 mm
<b>K9K 270</b>	10.2009 →	D (A)	4	1461 cm <sup>3</sup>	2V	78-81 kW	(106-110 PS)	16	80,50 mm
<b>K9K 274</b>		D (LA)	4	1461 cm <sup>3</sup>	2V	50 kW	(68 PS)	18,8:1	80,50 mm
<b>K9K 276</b>	06.2005 → 09.2012	D (LA)	4	1461 cm <sup>3</sup>	2V	62-66 kW	(84-90 PS)	18,8	80,50 mm
<b>K9K 278</b>	01.2007 → 12.2012	D (A)	4	1461 cm <sup>3</sup>	2V	76-78 kW	(103-106 PS)	15,3	80,50 mm
<b>K9K 282</b>	02.2007 → 12.2013	D (A)	4	1461 cm <sup>3</sup>	2V	76-78 kW	(103-106 PS)	15,3	80,50 mm
<b>K9K 292</b>	02.2007 →	D (A)	4	1461 cm <sup>3</sup>	2V	76-78 kW	(103-106 PS)	15,3	80,50 mm
<b>K9K 400 Euro 4</b>	02.2010 →	D (A)	4	1461 cm <sup>3</sup>	2V	63 kW	(86 PS)	15,9	80,50 mm
<b>K9K 410</b>	06.2010 →	D (A)	4	1461 cm <sup>3</sup>	2V	81 kW	(110 PS)		80,50 mm
<b>K9K 430</b>	01.2010 → 12.2013	D (A)	4	1461 cm <sup>3</sup>	2V	81 kW	(110 PS)		80,50 mm
<b>K9K 608 Euro 5</b>	02.2010 →	D (A)	4	1461 cm <sup>3</sup>	2V	63-66 kW	(86-90 PS)	15,9	80,50 mm
<b>K9K 628 Euro 6</b>	02.2010 →	D (A)	4	1461 cm <sup>3</sup>	2V	63-66 kW	(86-90 PS)	15,9	80,50 mm
<b>K9K 636 Euro 5</b>	06.2010 →	D (A)	4	1461 cm <sup>3</sup>	2V	81 kW	(110 PS)	15,2	80,50 mm
<b>K9K 646 Euro 6</b>	06.2010 →	D (A)	4	1461 cm <sup>3</sup>	2V	81 kW	(110 PS)	15,2	80,50 mm
<b>K9K 708</b>	06.2005 → 06.2010	D (A)	4	1461 cm <sup>3</sup>	2V	48-50 kW	(65-68 PS)	18,8	80,50 mm
<b>K9K 716</b>	09.2005 → 10.2009	D (A)	4	1461 cm <sup>3</sup>	2V	50-51 kW	(68-69 PS)	18,8	80,50 mm
<b>K9K 732</b>		D (A)	4	1461 cm <sup>3</sup>	2V	78 kW	(106 PS)	18,8	80,50 mm
<b>K9K 764</b>		D (A)	4	1461 cm <sup>3</sup>	2V	78 kW	(106 PS)	15,6	80,50 mm
<b>K9K 772</b>		D (A)	4	1461 cm <sup>3</sup>	2V	63-76 kW	(86-103 PS)	15,6	80,50 mm
<b>K9K 872 Euro 6</b>	06.2018 →	D (A)	4	1461 cm <sup>3</sup>	2V	59-85 kW	(80-116 PS)		80,50 mm

40 190 6..., 40 465 6..., 41 069 6..., 41 812 6..

	IN [2]	33,4 x 6 x 101,0	S - -	- 45° - -	22 - III	13201-00QAN 13201-BN700	<b>539018</b>
	EX [2]	28,9 x 6 x 100,8	RA/S- -	- 45° - -	22 - III	13202-00QAP 13202-BN700	<b>539017</b>
	[50]	∅ 6 mm					<b>MK-6H</b>
	IN/EX [4]	11,05 x 6 x 40,5	B1				<b>81-51000</b>
	IN/EX [4]	11,25/8.8 x 6 x 40,5	B1				<b>81-51001</b>

## 8

<b>K9K 718</b>	04.2006 → 10.2009	D (A)	4	1461 cm <sup>3</sup>	2V	50-62 kW	(68-84 PS)	18,8	80,50 mm
<b>K9K 892 Euro 4</b>	04.2011 →	D (A)	4	1461 cm <sup>3</sup>	2V	66 kW	(90 PS)	15,9	80,50 mm
<b>K9K 896 Euro 5</b>	06.2010 →	D (A)	4	1461 cm <sup>3</sup>	2V	81 kW	(110 PS)	15,5	80,50 mm

41 068 6..., 41 097 6..

	IN [2]	33,4 x 6 x 101,0	S - -	- 45° - -	22 - III	13201-00QAN 13201-BN700	<b>539018</b>
	EX [2]	28,9 x 6 x 100,8	RA/S- -	- 45° - -	22 - III	13202-00QAP 13202-BN700	<b>539017</b>
	[50]	∅ 6 mm					<b>MK-6H</b>
	IN/EX [4]	11,05 x 6 x 40,5	B1				<b>81-51000</b>
	IN/EX [4]	11,25/8.8 x 6 x 40,5	B1				<b>81-51001</b>
	(1) (ST)					13001-00Q0T	<b>50 007 076</b> (1)



					Reference	Item No.				
<b>9</b>		<b>76</b>								
<b>K9K 702</b>			D (A)	4	1461 cm <sup>3</sup>	2V	60 kW	(82 PS)	18,8	80,50 mm
<b>K9K 728</b>			D (A)	4	1461 cm <sup>3</sup>	2V	74-78 kW	(101-106 PS)	18,8	80,50 mm
41 068 6..										
									13001-00Q0T	<b>50 007 076</b> (1)
	(1)	(ST)								
<b>10</b>		<b>78</b>								
<b>HR12DE</b>		05.2010 →	BG (NA)	3	1198 cm <sup>3</sup>	4V	50-95 kW	(68-129 PS)	10,5	83,60 mm
	IN [4]	9,00 x 5 x 42,2	G2							<b>81-70004</b>
	IN [4]	9,20 x 5 x 42,2	G2							<b>81-70005</b> (1)
	EX [4]	9,00 x 5 x 42,2	G2							<b>81-70006</b>
	EX [4]	9,20 x 5 x 42,2	G2							<b>81-70007</b>
	(1)	1. oversize								
<b>11</b>		<b>78</b>								
<b>CA16</b>			B	4	1598 cm <sup>3</sup>	2V	62 kW	(84 PS)	9:1	83,60 mm
<b>CA16D</b>		02.1987 → 05.1989	B (NA)	4	1598 cm <sup>3</sup>	4V	79-81 kW	(107-110 PS)	10:1	83,60 mm
<b>CA16S</b>		08.1981 → 06.1991	B (NA)	4	1598 cm <sup>3</sup>	2V	60-66 kW	(82-90 PS)	9	83,60 mm
	IN [4]	11,03 x 7 x 45,0	G1						13212-D0110	<b>81-70001</b>
	EX [4]	11,03 x 7 x 48,0	G1							<b>81-70002</b>
<b>12</b>		<b>78</b>								
<b>HR16DE</b>		05.2005 →	AB (NA)	4	1598 cm <sup>3</sup>	4V	64-103 kW	(87-140 PS)	10,7	83,60 mm
	IN [2]	31,2 x 5 x 101,8	S - Ni -		- 45° -	-	1 -		13201-ED000	<b>701032</b>
									13201-ED00C	
	EX [2]	25,5 x 5 x 102,5	A - Ni -		- 45° -	-	1 -		13202-ED000	<b>701033</b>
									13202-ED00C	
	IN [4]	9,00 x 5 x 42,2	G2							<b>81-70004</b>
	IN [4]	9,20 x 5 x 42,2	G2							<b>81-70005</b> (1)
	EX [4]	9,00 x 5 x 42,2	G2							<b>81-70006</b>
	EX [4]	9,20 x 5 x 42,2	G2							<b>81-70007</b>
	(1)	1. oversize								
<b>13</b>		<b>79,5</b>								
<b>K4M 752</b>		08.2003 → 10.2009	B (NA)	4	1598 cm <sup>3</sup>	4V	70 kW	(95 PS)	10	80,50 mm
99 746 6..										
	IN [2]	32,5 x 5,5 x 109,2	S - -		- 45° -	-	1 - III		13201-00QAA	<b>531031</b>
	EX [2]	28,0 x 5,5 x 107,5	A/S - -		- 45° -	-	1 - III		13202-00QAA	<b>531032</b>
	[50]	∅ 5,5 mm								<b>LK-5.5H</b>
	IN/EX [4]	11,07 x 5.5 x 40,6	B1							<b>81-5136</b> (1)
	(1)	ohne Ventilschaftabdichtung/without valve stem gasket/sans joint de tige de soupape/sin junta de vástago de válvula/без уплотнения стержня клапана								
		AS								<b>50 006 315</b> (2)
		ES								<b>50 006 316</b> (2)
	(2)	(ST)								
	[8]	H 12 x 39 x 39								<b>50 006 437</b>
Fortsetzung nächste Seite / continued on next page / suite page suivante / continuación página próxima / Продолжение на следующей странице										

N

					Reference	Item No.
[4]					13257-00QAB	50 006 486
<b>14</b>	80					
<b>CA16DE</b>	09.1986 → 12.1987	B (NA)	4	1598 cm <sup>3</sup> 4V	85-91 kW (116-124 PS)	79,50 mm
[8]	H 31				13231-79S00	50 007 665
<b>15</b>	80					
<b>QG18DE</b>	07.1995 →	B (NA)	4	1769 cm <sup>3</sup> 4V	78-94 kW (106-128 PS)	9,5 88,00 mm
40 302 6..						
IN [2]	30,1 x 5,5 x 94,4	S - Ni -	- 45° - -	1 -	13201-AU300	701034
EX [2]	25,1 x 5,5 x 94,7	A - Ni -	- 45° - -	1 -	13202-AU300	701035
<b>16</b>	80					
<b>CD17</b>	03.1982 → 12.2008	D (NA)	4	1681 cm <sup>3</sup> 2V	40-41 kW (54-56 PS)	22,2 83,60 mm
IN [4]	11,03 x 7 x 45,0	G1			13212-D0110	81-70001
EX [4]	11,03 x 7 x 48,0	G1				81-70002
<b>17</b>	80					
<b>F9Q 760</b>	03.2001 →	D (A)	4	1870 cm <sup>3</sup> 2V	74 kW (101 PS)	19 93,00 mm
<b>F9Q 762</b>	03.2001 →	D (A)	4	1870 cm <sup>3</sup> 2V	60 kW (82 PS)	19 93,00 mm
<b>F9Q 772</b>	04.2002 → 08.2006	D (A)	4	1870 cm <sup>3</sup> 2V	60 kW (82 PS)	18,3 93,00 mm
99 561 6..						
IN [2]	35,3 x 7 x 110,9	S - -	- 45° - -	1 - III	13201-00QAC 13201-00QAM 13201-AW300	511013
EX [2]	32,6 x 7 x 110,7	A/S - -	- 45° - -	1 - III	13202-00QAN 13202-AW300	511014
[50]	∅ 7 mm					KK-7H
IN/EX [4]	12,06 x 7 x 38,3	B1				81-5135
[8]	M 35 x 30 x 33 x 7,55					50 007 540
[8]	M 35 x 30 x 33 x 7,6					50 007 541
[8]	M 35 x 30 x 33 x 7,65					50 007 542
[8]	M 35 x 30 x 33 x 7,7					50 007 543
[8]	M 35 x 30 x 33 x 7,75					50 007 544
[8]	M 35 x 30 x 33 x 7,8					50 007 545
[8]	M 35 x 30 x 33 x 7,85					50 007 546
[8]	M 35 x 30 x 33 x 7,9					50 007 547
[8]	M 35 x 30 x 33 x 7,95					50 007 548
[8]	M 35 x 30 x 33 x 8					50 007 549
<b>18</b>	80					
<b>R9M</b>	10.2011 →	D (A)	4	1598 cm <sup>3</sup> 4V	70-107 kW (95-146 PS)	15,4 79,50 mm
<b>R9M 413</b>	09.2016 →	D (A)	4	1598 cm <sup>3</sup> 4V	70-89 kW (95-121 PS)	15,4 79,50 mm
<b>R9M 452</b>	09.2016 →	D (A)	4	1598 cm <sup>3</sup> 4V	92-118 kW (125-160 PS)	15,4 79,50 mm
40 892 6..						
IN [2]	23,5 x 6 x 104,2	S - -	- 45° - -	22 - III		539044 <small>NEW</small>
EX [2]	23,4 x 6 x 104,1	RA/S- -	- 45° - -	22 - III		539045 <small>NEW</small>
[50]	∅ 6 mm					MK-6H
Fortsetzung nächste Seite / continued on next page / suite page suivante / continuación página próxima / Продолжение на следующей странице						

					Reference	Item No.	
[4]					13257-00Q0A	50 007 711	
<b>19</b>		<b>82,7</b>					
<b>F4R 720</b>	03.2001 →	B (NA)	4	1998 cm <sup>3</sup>	4V	88 kW (120 PS)	9,8 93,00 mm
<b>F4R 722</b>	03.2001 → 08.2006	B (NA)	4	1998 cm <sup>3</sup>	4V	88 kW (120 PS)	9,8 93,00 mm
IN [2]	33,4 x 5,5 x 110,1	S - -		- 45° - -	1 - III	13201-00QAE	<b>539011</b>
EX [2]	28,9 x 5,5 x 108,9	RA/S- -		- 45° - -	1 - III	13202-00QAE	<b>539014</b>
IN/EX [4]	11,07 x 5,5 x 40,6	B1					<b>81-5136</b> (1)
	(1) ohne Ventilschaftabdichtung/without valve stem gasket/sans joint de tige de soupape/sin junta de vástago de válvula/без уплотнения стержня клапана						
[8]	H 12 x 39 x 39						<b>50 006 437</b>
[4]					13257-00QAB		<b>50 006 486</b>
<b>20</b>		<b>82,7</b>					
<b>F4R 820</b>	04.2006 →	B (NA)	4	1998 cm <sup>3</sup>	4V	86 kW (117 PS)	9,8 93,00 mm
IN [2]	33,4 x 5,5 x 110,1	S - -		- 45° - -	1 - III	13201-00QAE	<b>539011</b>
EX [2]	28,9 x 5,5 x 108,9	RA/S- -		- 45° - -	1 - III	13202-00QAE	<b>539014</b>
IN/EX [4]	11,07 x 5,5 x 40,6	B1					<b>81-5136</b> (1)
	(1) ohne Ventilschaftabdichtung/without valve stem gasket/sans joint de tige de soupape/sin junta de vástago de válvula/без уплотнения стержня клапана						
<b>21</b>		<b>83</b>					
<b>CA18D</b>	08.1988 → 03.1994	B (NA)	4	1809 cm <sup>3</sup>	4V	92-99 kW (125-129 PS)	10,5:1 83,60 mm
<b>CA18ET</b>	08.1983 → 04.1990	B (A)	4	1809 cm <sup>3</sup>	2V	90-100 kW (122-136 PS)	8 83,60 mm
<b>CA18S</b>	08.1981 → 04.1990	B (NA)	4	1809 cm <sup>3</sup>	2V	65-74 kW (88-101 PS)	8,8 83,60 mm
<b>CA18T</b>	04.1984 → 11.1992	B (A)	4	1809 cm <sup>3</sup>	2V	99 kW (135 PS)	8:1 83,60 mm
<b>CA18i</b>	03.1989 → 06.1993	B (NA)	4	1809 cm <sup>3</sup>	2V	67 kW (91 PS)	8,8 83,60 mm
IN [4]	11,03 x 7 x 45,0	G1				13212-D0110	<b>81-70001</b>
EX [4]	11,03 x 7 x 48,0	G1					<b>81-70002</b>
<b>22</b>		<b>83</b>					
<b>CA18DET Euro 1</b>	07.1986 → 11.1993	B (A)	4	1809 cm <sup>3</sup>	4V	124-148 kW (169-201 PS)	8,5 83,60 mm
IN [4]	10,23 x 6 x 43,0	G1				13212-53J60	<b>81-70003</b>
[8]	H 31					13231-79S00	<b>50 007 665</b>
<b>23</b>		<b>83</b>					
<b>CA18DE</b>	07.1987 → 03.1994	B (NA)	4	1809 cm <sup>3</sup>	4V	93-99 kW (126-135 PS)	10,5 83,60 mm
IN [4]	11,03 x 7 x 45,0	G1				13212-D0110	<b>81-70001</b>
EX [4]	11,03 x 7 x 48,0	G1					<b>81-70002</b>
[8]	H 31					13231-79S00	<b>50 007 665</b>
<b>24</b>		<b>84</b>					
<b>M9R 630</b>	09.2006 →	D (LA)	4	1995 cm <sup>3</sup>	4V	66-84 kW (90-114 PS)	15,5 90,00 mm
Fortsetzung nächste Seite / continued on next page / suite page suivante / continuación página próxima / Продолжение на следующей странице							

**N**

						Reference	Item No.	
	IN [2] EX [2]	27,7 x 6 x 104,0 26,0 x 6 x 103,8	S - - A/S - -	- 45° - - - 45° - -	22 - III 22 - III	13201-00QOA 13202-00QOA	<b>539024</b> <b>539025</b>	
	[50]	∅ 6 mm					<b>MK-6H</b>	
	IN/EX [4]	11,05 x 6 x 42,4	B1				<b>81-51002</b> <small>NEW</small>	
	[8]	H 12 x 34,6 x 34,6				1323400Q0A	<b>50 006 432</b>	
<b>25</b>		<b>84</b>						
<b>M9R 780 Euro 4</b>	09.2006 →	D (LA) 4	1995 cm <sup>3</sup> 4V	66-84 kW	(90-114 PS) 16	90,00 mm		
<b>M9R 782</b>	09.2006 →	D (LA) 4	1995 cm <sup>3</sup> 4V	66 kW	(90 PS) 17	90,00 mm		
40 262 6..								
	IN [2] EX [2]	27,7 x 6 x 104,0 26,0 x 6 x 103,8	S - - A/S - -	- 45° - - - 45° - -	22 - III 22 - III	13201-00QOA 13202-00QOA	<b>539024</b> <b>539025</b>	
	[50]	∅ 6 mm					<b>MK-6H</b>	
	IN/EX [4]	11,05 x 6 x 42,4	B1				<b>81-51002</b> <small>NEW</small>	
	IN/EX [4]	11,25 x 6 x 42,4	B1				<b>81-51003</b> <small>NEW</small>	
		ES					<b>50 007 854</b>	
	[8]	H 12 x 34,6 x 34,6				1323400Q0A	<b>50 006 432</b>	
<b>26</b>		<b>84</b>						
<b>M1D Euro 4</b>	02.2007 → 12.2013	D (LA) 4	1994 cm <sup>3</sup> 4V	110 kW	(150 PS) 15,3	90,00 mm		
<b>M9R</b>	02.2007 →	D (LA) 4	1995 cm <sup>3</sup> 4V	110-130 kW	(150-177 PS) 16	90,00 mm		
<b>M9R 760</b>	06.2007 → 02.2014	D (LA) 4	1995 cm <sup>3</sup> 4V	127-130 kW	(173-177 PS) 16	90,00 mm		
40 262 6..								
	IN [2] EX [2]	27,7 x 6 x 104,0 26,0 x 6 x 103,8	S - - A/S - -	- 45° - - - 45° - -	22 - III 22 - III	13201-00QOA 13202-00QOA	<b>539024</b> <b>539025</b>	
	[50]	∅ 6 mm					<b>MK-6H</b>	
	IN/EX [4]	11,05 x 6 x 42,4	B1				<b>81-51002</b> <small>NEW</small>	
	IN/EX [4]	11,25 x 6 x 42,4	B1				<b>81-51003</b> <small>NEW</small>	
	[8]	H 12 x 34,6 x 34,6				1323400Q0A	<b>50 006 432</b>	
<b>27</b>		<b>84,5</b>						
<b>CA20E</b>	01.1983 → 10.1997	B (NA) 4	1974 cm <sup>3</sup> 2V	72-85 kW	(98-116 PS) 9,4	88,00 mm		
<b>CA20S</b>	08.1981 → 03.1992	B (NA) 4	1974 cm <sup>3</sup> 2V	66-81 kW	(90-110 PS) 8,5	88,00 mm		
	IN [4] EX [4]	11,03 x 7 x 45,0 11,03 x 7 x 48,0	G1 G1			13212-D0110	<b>81-70001</b> <b>81-70002</b>	
<b>28</b>		<b>84,5</b>						
<b>CD20</b>	07.1990 → 05.2002	D (NA) 4	1974 cm <sup>3</sup> 2V	55-56 kW	(75-76 PS) 22,2	88,00 mm		
<b>CD20T</b>	06.1991 → 07.2002	D (A) 4	1974 cm <sup>3</sup> 2V	66-67 kW	(90-91 PS) 22,2	88,00 mm		
	IN [4] EX [4]	11,03 x 7 x 45,0 11,03 x 7 x 48,0	G1 G1			13212-D0110	<b>81-70001</b> <b>81-70002</b>	
Fortsetzung nächste Seite / continued on next page / suite page suivante / continuación página próxima / Продолжение на следующей странице								

					Reference	Item No.		
[8]	H 35 x 26				13231-40L00 13231-40L05	<b>50 007 602</b>		
<b>29</b>	<b>84,5</b>							
<b>CD20ET</b>	09.1996 → 06.1999	D (LA)	4	1974 cm <sup>3</sup>	2V	71 kW (97 PS)	22,2	88,00 mm
[8]	H 35					13231-V7215	<b>50 007 666</b>	
<b>30</b>	<b>85</b>							
<b>RD28</b>	01.1985 → 08.2003	D (NA)	6	2826 cm <sup>3</sup>	2V	66-69 kW (90-94 PS)	21,2	83,00 mm
IN [4] EX [4]	11,03 x 7 x 45,0 11,03 x 7 x 48,0	G1 G1				13212-D0110	<b>81-70001</b> <b>81-70002</b>	
[8]	H 35 x 26					13231-40L00 13231-40L05	<b>50 007 602</b> (1)	
	(1) Ventillänge/valve length/longueur de soupape/longitud válvula/Длина клапан 101,8 mm							
<b>31</b>	<b>85</b>							
<b>RD28T</b>		D (A)	6	2826 cm <sup>3</sup>	2V	74-86 kW (101-117 PS)	21,2	83,00 mm
<b>RD28Ti</b>	06.1997 → 05.2000	D (A)	6	2826 cm <sup>3</sup>	2V	95-96 kW (129-131 PS)	21	83,00 mm
94 807 6..								
IN [4] EX [4]	11,03 x 7 x 45,0 11,03 x 7 x 48,0	G1 G1				13212-D0110	<b>81-70001</b> <b>81-70002</b>	
						13020 VB100	<b>50 006 330</b> (1)	
	(1) Schalenhartguss/chilled cast iron/pièce moulée trempée en surface/fundición en coquilla/Отливка с отбеленным поверхностным слоем							
[8]	H 35 x 26					13231-40L00 13231-40L05	<b>50 007 602</b> (2)	
	(2) Ventillänge/valve length/longueur de soupape/longitud válvula/Длина клапан 101,8 mm							
<b>32</b>	<b>85</b>							
<b>M9T</b>		D (LA)	4	2299 cm <sup>3</sup>	4V	74-125 kW (100-170 PS)	16	101,30 mm
<b>M9T 670 Euro 5</b>	11.2011 → 09.2016	D (A)	4	2299 cm <sup>3</sup>	4V	74-92 kW (101-125 PS)	16	101,30 mm
<b>M9T 672 Euro 5</b>	11.2011 → 09.2016	D (A)	4	2299 cm <sup>3</sup>	4V	74-92 kW (101-125 PS)	16	101,30 mm
<b>M9T 676 Euro 4</b>	11.2011 → 09.2016	D (A)	4	2299 cm <sup>3</sup>	4V	74-92 kW (101-125 PS)	16	101,30 mm
<b>M9T 678</b>	11.2011 → 06.2016	D (A)	4	2299 cm <sup>3</sup>	4V	107 kW (146 PS)	16	101,30 mm
<b>M9T 680</b>	11.2011 → 09.2016	D (A)	4	2299 cm <sup>3</sup>	4V	92-107 kW (125-145 PS)	16	101,30 mm
<b>M9T 686 Euro 5</b>	11.2011 → 09.2016	D (A)	4	2299 cm <sup>3</sup>	4V	92 kW (125 PS)	16	101,30 mm
<b>M9T 690 Euro 5</b>	11.2011 → 09.2016	D (A)	4	2299 cm <sup>3</sup>	4V	74-92 kW (101-125 PS)	16	101,30 mm
<b>M9T 692 Euro 4</b>	11.2011 → 09.2016	D (A)	4	2299 cm <sup>3</sup>	4V	66-92 kW (90-125 PS)	16	101,30 mm
<b>M9T 694 Euro 4</b>	11.2011 → 06.2016	D (A)	4	2299 cm <sup>3</sup>	4V	107 kW (146 PS)	16	101,30 mm
<b>M9T 696 Euro 4</b>	11.2011 → 09.2016	D (A)	4	2299 cm <sup>3</sup>	4V	92-107 kW (125-146 PS)	16	101,30 mm
<b>M9T 698 Euro 5</b>	11.2011 → 09.2016	D (A)	4	2299 cm <sup>3</sup>	4V	92-107 kW (125-146 PS)	16	101,30 mm
<b>M9T 702 Euro 5</b>	06.2014 → 09.2016	D (A)	4	2299 cm <sup>3</sup>	4V	100-120 kW (136-163 PS)	16	101,30 mm
<b>M9T 706 Euro 4/5</b>	11.2011 →	D (A)	4	2299 cm <sup>3</sup>	4V	107-125 kW (145-170 PS)	16	101,30 mm
<b>M9T 870 Euro 5</b>	11.2011 →	D (A)	4	2299 cm <sup>3</sup>	4V	74-92 kW (100-125 PS)	16	101,30 mm
<b>M9T 880 Euro 5</b>	02.2014 → 09.2016	D (A)	4	2299 cm <sup>3</sup>	4V	110 kW (150 PS)	16	101,30 mm
<b>M9T 896 Euro 4</b>	11.2011 → 09.2016	D (A)	4	2299 cm <sup>3</sup>	4V	92-110 kW (125-150 PS)	16	101,30 mm
97 504 6..								
IN [2] EX [2]	27,7 x 6 x 104,0 26,0 x 6 x 103,8	S - - A/S - -		- 45° - - - 45° - -		22 - III 22 - III	13201-00QOA 13202-00QOA	<b>539024</b> <b>539025</b>
[50]	∅ 6 mm						<b>MK-6H</b>	
Fortsetzung nächste Seite / continued on next page / suite page suivante / continuación página próxima / Продолжение на следующей странице								

N





					Reference	Item No.
	IN/EX [4]	11,05 x 6 x 42,4	B1			<b>81-51002</b> <small>NEW</small>
	[8]	H 12 x 34,6 x 34,6			1323400Q0A	<b>50 006 432</b>
<b>33</b>		<b>86</b>				
<b>SR20DI</b>	06.1990 → 03.1998	B (NA)	4	1998 cm <sup>3</sup> 4V	85 kW (116 PS)	9,5 86,00 mm
	IN [4]	10,23 x 6 x 43,0	G1		13212-53J60	<b>81-70003</b>
<b>34</b>		<b>86</b>				
<b>SR20De</b>	01.1991 → 07.2002	B (NA)	4	1998 cm <sup>3</sup> 4V	85 kW (115 PS)	9,5 86,00 mm
	IN [2]	34,1 x 6 x 98,4	S - Ni -	- 45° - -	1 -	13201-2J201 <b>701007</b>
	IN [4]	10,23 x 6 x 43,0	G1		13212-53J60	<b>81-70003</b>
<b>35</b>		<b>86</b>				
<b>YD22D</b>	10.1998 → 04.2004	D (NA)	4	2184 cm <sup>3</sup> 4V	84 kW (114 PS)	16,7 94,00 mm
<b>YD22DCi</b>		D (LA)	4	2184 cm <sup>3</sup> 4V	100-102 kW (136-139 PS)	18:1 94,00 mm
	IN [2]	28,2 x 6 x 106,7	A - Ni -	- 45° - -	1 -	13201-AD210 13201-BN300 13201-EB300 <b>701030</b>
	EX [2]	26,2 x 6 x 106,4	A - Ni -	- 45° - -	1 -	13202-AD210 13202-BN300 13202-EB300 <b>701031</b>
<b>36</b>		<b>86</b>				
<b>YD22DDT</b>	03.2000 →	D (A)	4	2184 cm <sup>3</sup> 4V	81-102 kW (110-139 PS)	18 94,00 mm
<b>YD22DDTi</b>	08.2000 → 01.2013	D (LA)	4	2184 cm <sup>3</sup> 4V	84-110 kW (114-150 PS)	16,7 94,00 mm
	IN [2]	28,2 x 6 x 106,7	A - Ni -	- 45° - -	1 -	13201-AD210 13201-BN300 13201-EB300 <b>701030</b>
	EX [2]	26,2 x 6 x 106,4	A - Ni -	- 45° - -	1 -	13202-AD210 13202-BN300 13202-EB300 <b>701031</b>
	IN [1]	10,04 x 6 x 59,8	G2		13212-AD260	<b>81-70008</b> <small>NEW</small>
	EX [1]	10,04 x 6 x 44,2	G2		13213-AD260	<b>81-70009</b> <small>NEW</small>
<b>37</b>		<b>86</b>				
<b>YD22ETi</b>	06.2001 → 01.2013	D (LA)	4	2184 cm <sup>3</sup> 4V	84-100 kW (114-136 PS)	16,3 94,00 mm
	IN [2]	28,2 x 6 x 106,7	A - Ni -	- 45° - -	1 -	13201-AD210 13201-BN300 13201-EB300 <b>701030</b>
	EX [2]	26,2 x 6 x 106,4	A - Ni -	- 45° - -	1 -	13202-AD210 13202-BN300 13202-EB300 <b>701031</b>
	IN [1]	10,04 x 6 x 59,8	G2		13212-AD260	<b>81-70008</b> <small>NEW</small>
	EX [1]	10,04 x 6 x 44,2	G2		13213-AD260	<b>81-70009</b> <small>NEW</small>
Fortsetzung nächste Seite / continued on next page / suite page suivante / continuación página próxima / Продолжение на следующей странице						



					Reference	Item No.	
	- - G - S -	- - - -			11039-EB30A 11039-EC00A 11040-EB300 11040-EB30A 11040-EC00A 11040-EC00C	<b>50 003 175</b>	
				40 Nm 180° 90° 40 Nm 90°			
<b>38</b>		<b>87</b>					
<b>G9T 722</b>	07.2002 →	D (LA)	4	2188 cm <sup>3</sup> 4V	66 kW (90 PS) 18	92,00 mm	
	IN [2] EX [2]	30,6 x 6 x 123,2 29,5 x 6 x 123,0	S - - A/S - -	- 45° - - - 45° - -	22 - III 22 - III	1320100QAD 1320200QAD	<b>539020</b> <b>539021</b>
	IN/EX [4]	11,04 x 6 x 50,0	B1				<b>81-5332</b>
	ES AS AS ES (1) (ST) (2) gegossene Version / cast Version / version coule / versión fundida / литая версия						<b>50 007 118</b> (1) <b>50 007 123</b> (1) <b>50 007 124</b> (2) <b>50 007 126</b> (2)
<b>39</b>		<b>89</b>					
<b>YD25DDTi</b>	03.1998 →	D (LA)	4	2488 cm <sup>3</sup> 4V	76-140 kW (103-190 PS) 17,5-18	100,00 mm	
40 363 6..							
	IN [2] EX [2]	28,2 x 6 x 106,7 26,2 x 6 x 106,4	A - Ni - A - Ni -	- 45° - - - 45° - -	1 - 1 -	13201-AD210 13201-BN300 13201-EB300 13202-AD210 13202-BN300 13202-EB300	<b>701030</b> <b>701031</b>
	IN [1] EX [1]	10,04 x 6 x 59,8 10,04 x 6 x 44,2	G2 G2			13212-AD260 13213-AD260	<b>81-70008</b> <b>81-70009</b>
	ES AS AS ES (1) Schalenhartguss/chilled cast iron/pièce moulée trempée en surface/fundición en coquilla/Отливка с отбелсным поверхностным слоем					13020-4KV0A 13020-4KV0C 13001-AU600 13020-AD212 13020-5M306 13020-AD202	<b>50 007 703</b> (1) <b>50 007 704</b> (1) <b>50 007 802</b> <b>50 007 803</b>
	- - G - S -	- - - -				11039-EB30A 11039-EC00A 11040-EB300 11040-EB30A 11040-EC00A 11040-EC00C	<b>50 003 175</b>
				40 Nm 180° 90° 40 Nm 90°			

**N**

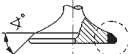
					Reference	Item No.
<b>40</b>		<b>89</b>				
<b>YD25ETI</b>	02.2002 →	D (LA)	4	2488 cm <sup>3</sup> 4V	96-98 kW (131-133 PS)	16,3 100,00 mm
	IN [1] EX [1]	10,04 x 6 x 59,8 10,04 x 6 x 44,2	G2 G2		13212-AD260 13213-AD260	<b>81-70008</b> <b>81-70009</b>
<b>41</b>		<b>89</b>				
<b>G9U 650 Euro 4</b>	04.2006 →	D (LA)	4	2463 cm <sup>3</sup> 4V	74-88 kW (101-120 PS)	18,1 99,00 mm
<b>G9U 720 Euro 3</b>	04.2002 →	D (LA)	4	2463 cm <sup>3</sup> 4V	73-84 kW (99-114 PS)	21 99,00 mm
<b>G9U 730 Euro 3</b>	07.2002 →	D (LA)	4	2463 cm <sup>3</sup> 4V	99 kW (135 PS)	21 99,00 mm
40 079 6..						
	IN [2] EX [2]	30,6 x 6 x 123,2 29,5 x 6 x 123,0	S - - A/S - -	- 45° - - - 45° - -	22 - III 22 - III	1320100QAD 1320200QAD
	IN/EX [4]	11,04 x 6 x 50,0	B1			<b>81-5332</b>
		ES AS AS ES (1) (ST) (2) gegossene Version / cast Version / version coule / versión fundida / литая версия				<b>50 007 118</b> (1) <b>50 007 123</b> (1) <b>50 007 124</b> (2) <b>50 007 126</b> (2)
<b>42</b>		<b>89</b>				
<b>YD25K3LD-5MI</b>	09.2006 →	D (LA)	4	2488 cm <sup>3</sup> 4V	100 kW (136 PS)	15,9 100,00 mm
		- - G - S -	- - -			11039-EB30A 11039-EC00A 11040-EB300 11040-EB30A 11040-EC00A 11040-EC00C
				40 Nm 180° 90° 40 Nm 90°		<b>50 003 175</b>
<b>43</b>		<b>89</b>				
<b>YD25EFi</b>		D (LA)	4	2488 cm <sup>3</sup> 4V	98 kW (133 PS)	100,00 mm
	IN [2] EX [2]	28,2 x 6 x 106,7 26,2 x 6 x 106,4	A - Ni - A - Ni -	- 45° - - - 45° - -	1 - 1 -	13201-AD210 13201-BN300 13201-EB300 13202-AD210 13202-BN300 13202-EB300
						<b>701030</b> <b>701031</b>
<b>44</b>		<b>107</b>				
<b>ISB4-4H Euro 4</b>	11.2006 →	D (LA)	4	4500 cm <sup>3</sup> 4V	136 kW (185 PS)	17,3 124,00 mm
<b>ISB4-4L Euro 4</b>	11.2006 →	D (LA)	4	4500 cm <sup>3</sup> 4V	103 kW (140 PS)	17,3 124,00 mm
<b>ISB4-6H Euro 4</b>	11.2006 →	D (LA)	6	6700 cm <sup>3</sup> 4V	184 kW (250 PS)	124,00 mm
<b>ISB4-6L Euro 4</b>	11.2006 →	D (LA)	6	6700 cm <sup>3</sup> 4V	165 kW (224 PS)	124,00 mm
	IN [2] EX [2]	33,0 x 7 x 124,7 33,0 x 7 x 124,3	S - Cr - A/S - Cr -	- 30° - - - 45° - -	9 - III 9 - III	<b>105-35632</b> <b>105-35633</b>
	[50]	∅ 7 mm				<b>RK-7H</b>
Fortsetzung nächste Seite / continued on next page / suite page suivante / continuación página próxima / Продолжение на следующей странице						

					Reference	Item No.
 IN [2] EX [2]	34,91 x 29.6 x 5,8 34,91 x 29.5 x 5,8	G1 20° G1 20°				92-17000 92-17001

		Cyl.		mm	cm <sup>3</sup>		Comp. Ratio ε	kW	PS	Pos
112		B (NA) 6	88 x 73	2664	2	8,65	92-96	125-131	95	
140		B (NA) 6	88 x 73	2664	2	9,2	105	143	95	
144.01		B (NA) 6	88 x 73	2664	2	9,2:1	85-96	116-131	95	
688	02, 13	B (NA) 4	70 x 72	1108	2		33-41	45-56	7	
688.01		B (NA) 4	70 x 72	1108	2	9	25-39	34-53	7	
688.06		B (NA) 4	70 x 72	1108	2	9,5:1	26	35	7	
688.09		B (NA) 4	70 x 72	1108	2	9,5:1	26	35	7	
688.10		B (NA) 4	70 x 72	1108	2	9,5	25-39	34-53	7	
688.11		B (NA) 4	70 x 72	1108	2	8,3-9,5	25-39	34-53	7	
689.01		B (NA) 4	65 x 72	956	2	8,5:1	29	39	2	
689.10		B (NA) 4	65 x 72	956	2	9,25:1	31-33	42-45	2	
712		D (NA) 4	98 x 110	3320	2	17,5:1	56	76	111	
797-20		D (A) 6	102 x 112	5491	2	17,5:1	95-98	129-133	114	
798		D (A) 6	102 x 112,1	5489	2	17:1	110-113	150-154	114	
798-20		D (A) 6	102 x 112	5490	2	17:1	113	154	114	
807		B (NA) 4	77 x 84	1565	2	8,6	49-61	67-83	29	
807.04		B (NA) 4	77 x 84	1565	2	8,6	61	83	29	
807.06		B	77 x 84	1565	2	8,6:1	61	83	29	
810	719, 725, 726, 729	B (NA) 4	73 x 77	1289	2		31-47	42-64	13	
810-02/97		B (NA) 4	73 x 77	1289	2	8,5	40	54	13	
810.01		B (NA) 4	73 x 77	1289	2	8,5	26-32	37-44	13	
810.02		B (NA) 4	73 x 77	1289	2	8,5	37	50	13	
810.03		B (NA) 4	73 x 77	1289	2	8,5	35	48	13	
810.05		B (NA) 4	73 x 77	1289	2	9,5	31-45	42-61	13	
810.06		B (NA) 4	73 x 77	1289	2	9,5	44	60	13	
810.10		B (NA) 4	73 x 77	1289	2	9,5:1	44	60	13	
810.19		B (NA) 4	73 x 77	1289	2	8,2:1	33	45	13	
810.25		B (NA) 4	73 x 77	1289	2	9,5:1	31-50	42-68	13	
810.26		B (NA) 4	73 x 77	1289	2	9,5:1	31-50	42-68	13	
810.29		B (NA) 4	73 x 77	1289	2	9,6:1	40	54	13	
813.02		B (NA) 4	61,4 x 72	852	2	8:1	21	29	1	
8140.21.235		D (A) 4	93 x 90	2445	2	18:1	68	92	101	
8140.27.2500		D (A) 4	93 x 92	2499	2		69	94	100	
8140.27.2510		D (A) 4	93 x 92	2499	2		69	94	100	
8140.27.2530 IDS Euro 1		D (A) 4	93 x 92	2499	2	18,5:1	71-78	96-106	100	
8140.27.2565 Euro 1		D (A) 4	94,4 x 100	2798	2	18,5:1	78	106	106	
8140.27.2580		D (A) 4	93 x 92	2499	2	22:1	72	98	100	
8140.27.2582		D (A) 4	93 x 92	2499	2	18,5:1	74-79	101-107	100	
8140.27.2590		D (A) 4	93 x 92	2499	2	18,5:1	69	94	105	
8140.47.2530 Euro 1		D (LA) 4	93 x 92	2499	2	18,5:1	85	116	103	
8140.47.2785 Euro 1		D (A) 4	93 x 92	2499	2	18,5:1	85	116	100	
8140.61.2300		D (NA) 4	93 x 90	2445	2	21	52	71	98	
8140.61.240		D (A) 4	93 x 90	2445	2	21:1	51	69	98	
8140.67.2500		D (NA) 4	93 x 92	2499	2	22	55	75	102	
8140.67.2510		D (NA) 4	93 x 92	2499	2	21	55	75	102	
8140.67.2550		D (NA) 4	93 x 92	2499	2	21	55	75	102	
8140.67.2580 Euro 2		D (NA) 4	93 x 92	2499	2	18,5	55	75	102	
829	710	B (NA) 4	88 x 82	1995	2	9,2	81	110	95	
841	726	B (NA) 4	79 x 84	1647	2	9,3	58	79	31	
841.25		B	79 x 84	1647	2	9,3:1	53-54	72-74	31	
843.20		B (NA) 4	79 x 84	1647	2	9,3:1	66-71	90-97	31	
843.21		B (NA) 4	79 x 84	1647	2	9,3:1	66-71	89-97	31	
847	700, 701, 720, 722	B (NA) 4	76 x 77	1397	2		35-47	48-64	17	
852	710, 720, 750	D (NA) 4	86 x 89	2068	2	21,5	43-49	58-67	89	
852		D (NA) 4	86 x 89	2068	2	21,5	47	64	89	
A 4.236		D	98,48 x 126,8	3864	2	16:1	37-65	50-89	112	
AKD	112-2	D (NA) 2	98 x 120	1810	2	19,5:1	14-18	20-24	110	
AKD	112-3	D (NA) 3	98 x 120	2715	2	19,5:1	24	33	110	
B 172 K		B	81 x 82,9	1709	2	10:1	59	80	57	
C1C	706, 754	B (NA) 4	65 x 72	956	2	8,6:1	24-31	33-42	2	
C1E	688, 700, 714, 715, 718, 719, 720, 726, 750, 752, 754, 756, 760, 762, 764, 792	B (NA) 4	70 x 72	1108	2		25-36	34-49	7	
C1G	700, 702, 710, 720, 722, 726, 730	B (NA) 4	71,5 x 77	1237	2	9,25	40-44	54-60	8	
C1J	700, 715, 742, 768, 780, 791, 792, 796	B (NA) 4	76 x 77	1397	2		35-53	48-72	17	
C1J	798	B	76 x 77	1397	2	9,25:1	53	72	17	
C1J	760, 764	B (A) 4	76 x 77	1397	2	8,05	69-87	105-118	17	
C1J	770, 782, 784, 788	B (LA) 4	76 x 77	1397	2		85-88	115-120	17	

			Cyl.		mm	cm <sup>3</sup>		Comp. Ratio $\epsilon$	kW	PS	Pos
C2J	700, 713, 717, 718, 720, 730, 755, 757, 760, 766, 767, 768, 770, 772, 776, 780, 781, 782, 784, 788, 789, 792, 794, 796, 797, 798	B (NA)	4		76 x 77	1397	2		43-53	58-72	17
C3G	700, 702, 710, 712, 720, 750	B (NA)	4		74 x 72	1239	2		40	54-55	14
C3J	762	B (NA)	4		75,8 x 77	1390	2	9	43-44	58-60	15
C3J	710, 760	B (NA)	4		75,8 x 77	1390	2		43-44	58-60	15
C3J	756	B (NA)	4		76 x 77	1397	2	9:1	43	58	17
C3J	700, 702	B (NA)	4		76 x 77	1397	2	9	43-44	58-60	17
D 225-2		D (NA)	2		95 x 120	1700	2	18:1	13-24	18-33	108
D 225-3		D (NA)	3		95 x 120	2550	2	18:1	35-37	48-50	109
D 226-3		D (NA)	3		105 x 120	3120	2	17,8:1	33-44	45-60	117
D 226-4		D (NA)	4		105 x 120	4160	2	18:1	44-64	60-87	117
D 226-6		D (NA)	6		105 x 120	6234	2	18:1	66-114	90-155	117
D 227-4		D (NA)	4		100 x 120	3768	2	18:1	46-61	63-83	113
D 227-6		D (NA)	6		100 x 120	5654	2	18:1	63-91	86-124	113
D 325-2		D (NA)	2		95 x 120	1700	2	18:1	21-25	29-34	108
D 325-3		D (NA)	3		95 x 120	2551	2	18:1	25-35	34-48	108
D 325-4		D (NA)	4		95 x 120	3400	2	18:1	43-51	58-69	108
D 327-2		D (NA)	2		100 x 120	1885	2	18:1	24-27	33-37	113
D 327-3		D (NA)	3		100 x 120	2827	2	18:1	26-48	35-65	113
D 327-4		D (NA)	4		100 x 120	3768	2	18:1	45-55	61-75	113
D4D	752	B	4		69 x 76,8	999	4	9,6:1	44	60	5
D4D	706	B	4		69 x 66,8	999	4	9,6:1	44	60	5
D4D	700, 712, 720, 754	B (NA)	4		69 x 66,8	999	4	9,8	44-59	60-80	5
D4F	702, 706, 712, 714, 716, 722, 728, 730, 732, 734, 764, 770, 772, 784, 786, 790	B (NA)	4		69 x 76,8	1149	4		43-76	58-103	5
D4F Euro 3	708	B (NA)	4		69 x 76,8	1149	4	9,8	44	60	5
D4F	44 kW, 48 kW, 726	B	4		69 x 76,8	1149	4		44-55	60-75	5
D4F	740, 744	BG (NA)	4		69 x 76,8	1149	4	9,8	48-55	65-75	3
D4F	742	AB (NA)	4		69 x 76,8	1149	4	9,8	55-58	75-79	6
D4F	780	B (LA)	4		69 x 76,8	1149	4	9,5	74-75	100-102	5
D4F Euro 5	782	B (LA)	4		69 x 76,8	1149	4	9,5	74-75	101-102	5
D7F	700, 701, 702, 703, 704, 706, 708, 710, 720, 722, 726, 730, 744, 746, 764, 800	B (NA)	4		69 x 76,8	1149	2		40-44	54-60	4
D7F Euro 4	766	B (NA)	4		69 x 76,8	1149	2	9,6	43	58	4
DXi Euro 3	11 330, 11 440	D (A)	6		123 x 152	10837	4	18:1	243-324	330-441	122
DXi Euro 4/5	11 370, 11 450	D (A)	6		123 x 152	10837	4	18:1	272-332	370-451	123
DXi Euro 4/5	13 440, 13 480, 13 520	D (LA)	6		131 x 158	12777	4	18:1	323-382	440-520	126
DXi Euro 4/5	13 460, 13 500	D (LA)	6		131 x 158	12777	4	18:1	338-368	460-500	127
E5F	716	B	4		75,8 x 64,9	1171	2	8,8:1	40-44	55-60	16
E5F	710	B (NA)	4		75,8 x 64,9	1171	2	8,8	40-44	55-60	16
E6J	712, 713, 718, 738	B (NA)	4		75,8 x 77	1390	2		43-57	60-80	16
E6J	700, 701, 706, 734, 760	B (NA)	4		75,8 x 77	1390	2	9,5	43-60	60-82	16
E7F	700, 704, 706, 730	B (NA)	4		75,8 x 64,9	1171	2		40-46	54-63	16
E7F	708, 750	B (NA)	4		75,8 x 64,9	1171	2		43-48	58-65	16
E7J	626, 720, 724, 728, 742, 780	B (NA)	4		75,8 x 77	1390	2	9,5	43-59	58-80	16
E7J	601, 624, 634, 635, 700, 706, 707, 710, 711, 718, 719, 726, 745, 754, 756, 757, 764, 770, 771, 773	B (NA)	4		75,8 x 77	1390	2		52-59	71-80	16
F1N	720, 722, 724	B (NA)	4		81 x 83,5	1721	2	9,5	50-51	68-69	56
F2N	700, 704, 708, 710, 711, 716, 720, 721, 722, 726, 727, 728, 730, 732, 740, 742, 750, 753, 754, 758, 770, 783, 786, 796, 797	B (NA)	4		81 x 83,5	1721	2		54-69	73-94	56
F2N	712, 724, 752, 798	B (NA)	4		81 x 83,5	1721	2		55-65	75-88	56
F2R	702	B	4		81 x 83,5	1721	2	9,5:1	66	90	56
F3N	702, 716, 717, 718, 723, 726, 740, 741, 742, 743, 746	B (NA)	4		81 x 83,5	1721	2		54-80	73-109	56
F3N	708, 722	B (NA)	4		81 x 83,5	1721	2	9,5	66-70	90-95	56
F3P	682, 712, 714, 720, 724	B (NA)	4		82,7 x 83,5	1794	2		65-80	88-109	61
F3P	674, 678, 700, 704, 705, 706, 707, 708, 710, 760, 765	B (NA)	4		82,7 x 83,5	1794	2	9,7	65-83	88-110	61
F3P	755	B (NA)	4		82,7 x 83	1783	2	9,8	66	90	60
F3P	670, 676	B (NA)	4		82,7 x 83,5	1794	2	9,7	66-70	90-95	60
F3P	744, 745, 748	B	4		82,7 x 83,5	1794	2	9,8:1	66-80	90-109	60
F3P	754, 758	B (NA)	4		82,7 x 83,5	1794	2	9,8	66-80	90-109	60
F3P	764	B (NA)	4		82,7 x 83	1783	2	9,7	79	107	61
F3R	750, 751, 752, 791, 797	B (NA)	4		82,7 x 93	1998	2	9,7	80-85	109-115	60
F3R	722, 723, 742, 769, 796, 798	B (NA)	4		82,7 x 93	1998	2		80-85	109-115	61

R

Cyl.	mm	cm <sup>3</sup>	Comp. Ratio $\epsilon$	kW	PS	Pos			
F3R	611	B (NA) 4	82,7 x 93	1998	2	9,5	80-85	109-116	61
F3R	768	B (NA) 4	82,7 x 93	1998	2	9,8	84	114	63
F3R	728, 729	B (NA) 4	82,7 x 93	1998	2	9,8	84	114	64
F4P	720, 722, 760, 770, 774	B (NA) 4	82,7 x 83	1783	4	9,8	85-89	115-121	65
F4P	773	B (NA) 4	82,7 x 83	1783	4	9,8	85-89	116-121	68
F4P	771, 772, 775	B (NA) 4	82,7 x 83	1783	4	9,8	85-89	116-121	67
F4R	712, 713, 714, 715, 720, 730, 732, 736, 740, 741, 744, 746, 747, 770, 771, 780, 790, 791, 792, 820, 830	B (NA) 4	82,7 x 93	1998	4		86-148	117-200	65
F4R	700, 701, 722	B (NA) 4	82,7 x 93	1998	4	9,8	88-103	120-140	65
F4R	401, 414	B 4	82,7 x 93	1998	4		98	133	68
F4R	400, 402, 403, 408, 410, 867	B (NA) 4	82,7 x 93	1998	4		98-109	133-148	68
F4R	404, 405, 412, 416	AB (NA) 4	82,7 x 93	1998	4		98-110	133-150	71
F4R	769	B (LA) 4	82,7 x 93	1998	4	9,5:1	120	163	69
F4R	760, 761, 762, 763, 764, 765, 776, 784, 787, 796	B (A) 4	82,7 x 93	1998	4	9,5	120-125	163-170	65
F4R	774, 786, 794, 795, 797, 800, 811, 813, 886, 887	B (LA) 4	82,7 x 93	1998	4		120-169	163-230	65
F4R Euro 3	738	B (NA) 4	82,7 x 93	1998	4	11	124-132	168-180	65
F4R Euro 4	766, 767	B (A) 4	82,7 x 93	1998	4	9,5	125	170	65
F4R	870, 872, 896, 897	B (LA) 4	82,7 x 93	1998	4		125-140	170-190	68
F4R Euro 4	832	B (NA) 4	82,7 x 93	1998	4	11,5	145-148	197-201	68
F4R Euro 5	874	B (LA) 4	82,7 x 93	1998	4	8,5	162-202	220-275	68
F4Rt 774 Euro 4		B (A) 4	82,7 x 93	1998	4	9	165	224	65
F4Rt 800 Euro 4		B (A) 4	82,7 x 93	1998	4		150	204	68
F4Rt 811 Euro 4		B (A) 4	82,7 x 93	1998	4	9,5	125	170	65
F5R	700, 701, 740	B (NA) 4	82,7 x 93	1998	4	10	103	140	66
F7P	704	B (NA) 4	82 x 83,5	1764	4	10,1	99-101	135-137	59
F7P	720, 722	B (NA) 4	82 x 83,5	1764	4		99-103	135-140	58
F7P	700	B (NA) 4	82 x 83,5	1764	4	10	101-103	137-140	58
F7R	700	B (NA) 4	82,7 x 93	1998	4	10	108-110	147-150	62
F7R	710, 714, 720	B (NA) 4	82,7 x 93	1998	4		108-110	147-150	62
F7R	712	B (NA) 4	82,7 x 93	1998	4	9,8:1	110	150	70
F8M	700, 720, 730, 736, 760	D (NA) 4	78 x 83,5		2	22,5	40	55	30
F8Q	630, 662	D (NA) 4	80 x 93	1870	2	21,5	40-48	54-65	47
F8Q	640, 706, 710	D (NA) 4	80 x 93	1870	2	21,5	40-48	54-65	40
F8Q	648, 680, 682	D (NA) 4	80 x 93	1870	2		40-66	54-90	43
F8Q	606, 620, 624, 644, 646, 676, 678, 684, 696, 714, 722, 724, 730, 732, 742, 764, 774, 776	D (NA) 4	80 x 93	1870	2		40-66	54-90	42
F8Q	636	D (NA) 4	80 x 93	1870	2	21,5:1	45	61	54
F8Q	622	D (NA) 4	80 x 93	1870	2	21,5	47	64	41
F8Q	632, 790	D (NA) 4	80 x 93	1870	2	21,5	47-48	64-65	45
F8Q	672, 692, 704	D 4	80 x 93	1870	2	21,5:1	47-48	64-65	40
F8Q	610, 731, 736, 740, 744, 768, 785, 788	D (A) 4	80 x 93	1870	2		47-72	64-98	40
F8Q	786	D (A) 4	80 x 93	1870	2	20,5	66	90	44
F8Q	784	D (A) 4	80 x 93	1870	2	20,5	66-76	90-104	41
F9Q	738	D (A) 4	80 x 93	1870	2	19	59-79	80-107	51
F9Q	718, 750, 751, 752, 754, 760, 762, 770, 772, 780, 782, 790	D (A) 4	80 x 93	1870	2		59-92	80-125	50
F9Q	744, 800, 804	D (A) 4	80 x 93	1870	2		59-97	80-132	51
F9Q	716, 730, 734	D (A) 4	80 x 93	1870	2	18,3	60-75	82-102	46
F9Q	650, 664, 670, 674, 680, 746, 748, 756, 758, 759, 774, 803, 808, 812, 816, 818, 820, 826, J 803	D (A) 4	80 x 93	1870	2		60-96	82-131	49
F9Q	722	D (A) 4	80 x 93	1870	2	18,3	72	98	48
F9Q	720	D (A) 4	80 x 93	1870	2	18,3:1	72	98	55
F9Q	710, 717, 731, 736	D (A) 4	80 x 93	1870	2	18,3	72-75	98-102	46
F9Q	732, 733, 740	D (A) 4	80 x 93	1870	2	19	74-77	101-105	50
F9Q Euro 4	E 804, EE 804	D (A) 4	80 x 93	1870	2	17	81-96	110-131	51
G8T	706, 752, 790, 792, 794	D (NA) 4	87 x 92	2188	3		61	83	90
G8T	740	D (LA) 4	87 x 92	2188	3	22	83	113	92
G8T	716	D (A) 4	87 x 92	2188	3	22	83	113	92
G8T	760	D (LA) 4	87 x 92	2188	3	22	83	113	91
G8T	714	D (LA) 4	87 x 92	2188	3	22	83	113	93
G9T	720	D (A) 4	87 x 92	2188	4	18	66	90	94
G9T	607, 642, 700, 703, 706, 707, 710, 712, 722, 750	D (LA) 4	87 x 92	2188	4		66-110	90-150	94
G9T Euro 4	600, 605, 606, 645	D (A) 4	87 x 92	2188	4	18	78-102	106-139	94
G9T Euro 3	702	D (A) 4	87 x 92	2188	4	18	83-110	113-150	94



			Cyl.		mm	cm <sup>3</sup>		Comp. Ratio $\epsilon$	kW	PS	Pos
G9T Euro 3	742, 743	D (LA)	4		87 x 92	2188	4	18	110	150	94
G9U Euro 3	720, 724, 730, 750, 754	D (LA)	4		89 x 99	2463	4		73-99	99-135	96
G9U Euro 4	630, 632, 650	D (LA)	4		89 x 99	2463	4		74-107	101-146	96
H4B	400, 401, 408	B (A)	3		72,2 x 73,1	898	4	9,5	56-80	76-109	11
H4B	451	BG (A)	3		72,2 x 73,1	898	4		66	90	9
H4B	410, 453	B (A)	3		72,2 x 73,1	898	4		66-68	90-92	12
H5F Filter	400, 403, 404, 408, 412	B (A)	4		72,2 x 73,1	1197	4	10	74-97	101-132	10
J5R	716, 718, 722, 726, 728	B (NA)	4		88 x 82	1995	2	9,2	57-81	78-84	95
J5R	A7	B	4		88 x 82	1995	2	9,2:1	61	83	95
J6R	234, 236, 706, 707, 710, 712, 713, 714, 715, 716, 726, 734, 758, 759, 760, 762, 763, 792, 793	B (NA)	4		88 x 82	1995	2		69-81	101-110	95
J7R	768	B (NA)	4		88 x 82	1995	2	9,2	76	103	95
J7R	722, 723, 732, 733, 738, 739, 746, 747, 750, 751, 760	B (NA)	4		88 x 82	1995	2		77-99	105-135	95
J7R	730	B	4		88 x 82	1995	2	10:1	88	120	95
J7R	720, 726, 740, 754	B (NA)	4		88 x 82	1995	3	9,3	98-103	133-140	95
J7R	721	B (NA)	4		88 x 82	1995	3	9,3	103	140	95
J7R	756	B (A)	4		88 x 82	1995	2	8,5	119	162	95
J7R	752	B (A)	4		88 x 82	1995	2	8	129	175	95
J7T	600, 718, 732, 733, 755, 762, 770, 772, 773, 776, 788	B (NA)	4		88 x 89	2165	2		59-91	91-116	95
J7T	706, 707, 708, 714, 715, 719, 730, 731, 736, 754, 756, 763, 780, 782	B (NA)	4		88 x 89	2165	2		67-91	91-124	95
J7T	760	B (NA)	4		88 x 89	2165	3	9,2	101	137	95
J7T	766, 767	B	4		88 x 89	2165	3	9,2:1	101-103	137-140	95
J8S	330, 600, 620, 704, 706, 711, 736, 740, 758, 784	D (NA)	4		86 x 89	2068	2		44-53	60-72	89
J8S	240, 604, 702, 712, 714, 742, 746, 760, 774, 776, 778, 786, 788, 890	D (A)	4		86 x 89	2068	2		63-66	86-90	89
J8S	610, 612, 708, 738, 772, 814	D (LA)	4		86 x 89	2068	2		63-66	86-90	89
K4J	712, 713, 714, 730, 732	B (NA)	4		79,5 x 70	1390	4	10	60-72	82-98	33
K4J	718	B (NA)	4		79,5 x 70	1390	4		70	95	35
K4J	740, 750, 770, 780	B (NA)	4		79,5 x 70	1390	4	10	70-72	95-98	33
K4J	700, 715	B (NA)	4		79,5 x 70	1390	4	10	70-72	95-98	34
K4J Euro 4	710, 711	B (NA)	4		79,5 x 70	1390	4	10	72	98	33
K4M	670, 674, 680	B	4		79,5 x 80,5	1598	4				35
K4M Euro 4	744, 745, 830	B (NA)	4		79,5 x 80,5	1598	4		55-85	75-107	33
K4M	711, 716, 734, 736, 760, 761, 762, 768, 782, 788, 790, 791, 792, 794	B (NA)	4		79,5 x 80,5	1598	4		58-83	79-113	34
K4M	694, 850	AB (NA)	4		79,5 x 80,5	1598	4		60-81	82-106	39
K4M	800, 801, 804, 812, 813	B (NA)	4		79,5 x 80,5	1598	4		65-82	88-112	36
K4M	690, 698, 700, 701, 704, 706, 708, 709, 710, 712, 714, 730, 732, 740, 742, 743, 746, 750, 752, 753, 754, 764, 776	B (NA)	4		79,5 x 80,5	1598	4		66-98	90-133	33
K4M	755	B	4		79,5 x 80,5	1598	4	10:1	70	95	34
K4M Euro 4	260, 496, 497	B	4		79,5 x 80,5	1598	4		74-81	101-110	35
K4M Euro 4	831, 834, 842, 848, 856, 858, 862	B (NA)	4		79,5 x 80,5	1598	4		74-98	101-133	35
K4M	616, 696, 707, 718, 766, 780, 878, 838, 839, 845, 866	B (NA)	4		79,5 x 80,5	1598	4		75-86	102-116	35
K4M	697, 748	AB (NA)	4		79,5 x 80,5	1598	4		76-86	103-117	38
K4M	720	B (NA)	4		79,5 x 80,5	1598	4	10	79	107	33
K4M	724	B (NA)	4		79,5 x 80,5	1598	4	10	79	107	34
K4M Euro 4	824	B (NA)	4		79,5 x 80,5	1598	4	9,8	81	110	36
K4M	C 812, C 813	B (NA)	4		79,5 x 80,5	1598	4	10,0:1	82	112	37
K4M Euro 4/5	854	B (NA)	4		79,5 x 80,5	1598	4	11	98	133	34
K7J	700, 701	B (NA)	4		75,8 x 77	1390	2	9,5	55-72	75-98	16
K7J	710	B (NA)	4		79,5 x 70	1390	2	9,5	55	75	32
K7J	712	B	4		79,5 x 70	1390	2	10:1	70	95	32
K7M	720, 744, 745, 746, 790	B (NA)	4		79,5 x 80,5	1598	2		54-73	75-100	32
K7M Euro 4	718, 732	B (NA)	4		79,5 x 80,5	1598	2		62-66	84-90	32
K7M	702, 703, 704, 710, 750	B (NA)	4		79,5 x 80,5	1598	2		64-76	87-103	32
K9K	700, 702, 704, 710, 714, 722, 728, 729, 750	D (A)	4		76 x 80,5	1461	2		42-78	57-106	18
K9K	706, 716, 724, 732, 734, 762, 764, 768, 800	D (A)	4		76 x 80,5	1461	2		45-78	61-106	19
K9K	752, 766	D (A)	4		76 x 80,5	1461	2		47-65	64-88	22
K9K	500, 608, 609, 612, 628, 646, 647, 740, 760, 770, 772, 782, 808, 812, 820, 834, 836, 838, 840, 873	D (A)	4		76 x 80,5	1461	2		47-85	64-116	21

**R**

Cyl.	Cyl.	mm	cm <sup>3</sup>	Comp. Ratio ε	kW	PS	Pos		
								mm	cm <sup>3</sup>
K9K	790	D (A) 4	76 x 80,5	1461	2	18,3	48	65	26
K9K	260, 262, 272	D (LA) 4	76 x 80,5	1461	2	18,8:1	48	65	21
K9K	792, 794, 796	D (A) 4	76 x 80,5	1461	2		48-63	65-86	24
K9K Euro 4	780, 802, 804	D (A) 4	76 x 80,5	1461	2	15,6	50-81	68-110	19
K9K	830, 856, 858, 872, 898	D (A) 4	76 x 80,5	1461	2		59-85	80-116	25
K9K	718	D (A) 4	76 x 80,5	1461	2	18,8	60-62	82-84	20
K9K Filter	629	D (A) 4	76 x 80,5	1461	2	15,5	66	90	21
K9K Euro 5	656, 846	D (A) 4	76 x 80,5	1461	2		66-81	90-110	25
K9K Euro 5	636, 657, 816, 826, 837, 838, 884	D (A) 4	76 x 80,5	1461	2		66-81	90-110	21
K9K Euro 3	712	D (A) 4	76 x 80,5	1461	2	18,8	74	100	18
K9K Euro 4	774, 806, 832	D (A) 4	76 x 80,5	1461	2		76-78	103-106	21
K9K	P 732	D (A) 4	76 x 80,5	1461	2	18,8	78	106	23
K9K	658, 675, 886	D (A) 4	76 x 80,5	1461	2		80-81	109-110	28
K9K	896	D (A) 4	76 x 80,5	1461	2	15,2	81	110	27
M9R Euro 4	780	D (LA) 4	84 x 90	1995	4	16	66-84	90-114	77
M9R	782	D (LA) 4	84 x 90	1995	4	15,7	66-84	90-114	77
M9R Euro 4	786, 805	D (LA) 4	84 x 90	1995	4		66-110	90-150	73
M9R	610, 615, 630, 700, 721, 722, 724, 740, 742, 744, 746, 748, 750, 760, 761, 762, 763, 800, 802, 804, 809, 814, 815, 816, 817, 820, 824, 830, 832, 833	D (LA) 4	84 x 90	1995	4		66-132	90-180	73
M9R	784	D (LA) 4	84 x 90	1995	4		84	114	82
M9R Euro 5	692	D (A) 4	84 x 90	1995	4	15,5	84	114	76
M9R	756, D 833	D (LA) 4	84 x 90	1995	4		96-110	131-150	81
M9R	828, 846, 850, 854, 857, 858	D (LA) 4	84 x 90	1995	4	15,7	96-131	131-178	75
M9R	754, 808	D (LA) 4	84 x 90	1995	4	15,7	110	150	78
M9R	834, 835, 836, 838	D (LA) 4	84 x 90	1995	4	15,7	110	150	80
M9R Euro 4	A 700, B 721	D (A) 4	84 x 90	1995	4	15,7:1	110	150	76
M9R	B 610, C 613, C 615, C 830, G 832	D (LA) 4	84 x 90	1995	4		110-118	150-160	76
M9R	844, 845, 849, 855, 864	D (LA) 4	84 x 90	1995	4		110-127	150-173	79
M9R Euro 4	856, 862, 865, 866	D (LA) 4	84 x 90	1995	4	15,7	110-127	150-173	79
M9R Euro 4	859	D (LA) 4	84 x 90	1995	4	15,7	127	173	75
M9R	806, 812	D (LA) 4	84 x 90	1995	4		127	173	74
M9R Euro 5	891	D (LA) 6	84 x 90,2	2998	4	15,7:1	173	235	80
M9Ra 742 Euro 4		D (A) 4	84 x 90	1995	4	16,0:1	96-110	131-150	83
M9Rk 800 Euro 4		D (A) 4	84 x 90	1995	4	16,0:1	127	173	76
M9Rk 802 Euro 4		D (A) 4	84 x 90	1995	4	16,0:1	96-110	131-150	76
M9Rk 805 Euro 4		D (A) 4	84 x 90	1995	4	16,0:1	110	150	76
M9Rk 816 Euro 4		D (A) 4	84 x 90	1995	4	16:1	131	178	76
M9T	892	D	85 x 101,3	2298	4	16:1			85
M9T	606	D	85 x 101,3	2298	4	16:1			88
M9T Euro 4/5	870, 872	D (A) 4	85 x 101,3	2298	4		74-92	100-125	85
M9T Euro 4	676, 692, 694, 696	D (A) 4	85 x 101,3	2298	4	16	74-110	101-150	84
M9T Euro 5	670, 672, 686, 690, 698	D (A) 4	85 x 101,3	2298	4	16	74-110	101-150	84
M9T Euro 5	700, 702, 880, 890	D (A) 4	85 x 101,3	2298	4	16	74-120	100-163	85
M9T Euro 4	882	D (A) 4	85 x 101,3	2298	4		92-96	125-131	85
M9T	678, 680	D (A) 4	85 x 101,3	2298	4	16	92-107	125-146	84
M9T Euro 5	898	D (A) 4	85 x 101,3	2298	4	16	92-110	125-150	86
M9T Euro 4	896	D (A) 4	85 x 101,3	2298	4	16	92-110	125-150	86
M9T Euro 4/5	706	D (A) 4	85 x 101,3	2299	4	16	107-125	145-170	86
M9T	260	D (LA) 4	85 x 101,3	2298	4	16	120-140	163-190	87
MID	06.20.30 G	D (NA) 6	120 x 130	8822	2	17:1	141	192	121
MIDR 06.02.12		D (LA) 6	102 x 112	5491	2	17:1	128-134	173-182	114
MIDR 06.02.26 DU		D (LA) 6	102 x 126	6177	2		166	226	115
MIDR 06.02.26 I		D (LA) 6	102 x 126	6177	2		133	181	116
MIDR 06.02.26 K		D (LA) 6	102 x 126	6177	2		155	211	116
MIDR 06.02.26 L		D (LA) 6	102 x 126	6177	2		132	180	116
MIDR 06.02.26 L2		D (LA) 6	102 x 126	6177	2		132	180	116
MIDR 06.02.26 M		D (LA) 6	102 x 126	6177	2		155	211	116
MIDR 06.02.26 M2		D (LA) 6	102 x 126	6177	2		155	211	116
MIDR 06.20.30		D (LA) 6	120 x 130	8822	2	15:1	194	264	121
MIDR 06.20.45 BC		D (LA) 6	120 x 145	9839	2		195	265	121
MIDR 06.20.45 C		D (LA) 6	120 x 145	9839	2	16:1	206-210	280-285	121
MIDR 06.20.45 DD		D (LA) 6	120 x 145	9839	2	18:1	222	302	121
MIDR 06.23.56 B/43 Euro 3		D (LA) 6	123 x 156	11122	2	17:1	303	412	124
MIDR 06.24.65 AB Euro 2		D (LA) 6	124 x 165	11955	4		287	390	125
MIDS 06.02.12		D (A) 6	102 x 112	5491	2		107	145	114
MIDS 06.02.12 B		D (A) 6	102 x 112	5491	2	17:1	113-117	154-159	114
MIDS 06.02.12 D		D (A) 6	102 x 112	5491	2	17:1	110	150	114

			Cyl.		mm	cm <sup>3</sup>		Comp. Ratio $\epsilon$	kW	PS	Pos
MIDS 06.20.45 D			D (A) 6		120 x 145	9839	2	17:1	129	175	121
MIDS 06.35.40 B			D (A) 6		135 x 140	12024	2		225	306	128
MIDS 06.35.40 E			D (A) 6		135 x 140	12024	2	15:1	195	265	128
MIP	06.20.30		D (NA) 6		120 x 130	8820	2	17:1	141-158	192-215	121
MIPR 06.20.45			D (LA) 6		120 x 145	9840	2	17:1	195-265	265-360	121
MIPS 06.20.30			D (A) 6		120 x 130	8820	2		166	225	121
MIPS 06.20.45			D (LA) 6		120 x 145	9840	2	17:1	137-186	186-253	121
N7Q	711		B (NA) 4		83 x 90	1948	4	10,5	100	136	72
N7Q	700, 704, 710		B (NA) 4		83 x 90	1948	4	10,5	100-102	136-139	72
R9M	408, 413, 414, 450, 452, 453		D (A) 4		80 x 79,5	1598	4	15,4	66-120	90-163	53
R9M Euro 5	409		D (A) 4		80 x 79,5	1598	4	15,4	96	130	53
R9M Euro 5	402, 404		D (A) 4		80 x 79,5	1598	4	15,4	96	130	52
S8U	720, 722, 730, 731, 748		D (NA) 4		93 x 90	2445	2		50-55	68-75	99
S8U	742, 750, 752, 758, 780		D (NA) 4		93 x 92	2499	2	22	55-58	75-79	99
S8U	770		D (A) 4		93 x 92	2499	2	22,5	59	80	99
S8U	762		D (LA) 4		93 x 92	2499	2	21	83	113	99
S8U	763		D (LA) 4		93 x 92	2499	2	21	83	113	104
S9U			D (A) 4		93 x 92	2499	2	17,5:1	55	75	99
S9U	700, 702, 704, 714, 740		D (A) 4		93 x 92	2499	2		69-72	94-98	99
S9W Euro 2	702		D (A) 4		94,4 x 100	2799	2	19	84	114	107
TD 226 B-6			D (A) 6		105 x 120	6234	2	16,4:1	81-136	110-185	118
TD 226-4			D (A) 4		105 x 120	4160	2	15,5:1	68-74	93-100	119
TD 228-6			D (A) 6		105 x 120	6234	2	16:1	99-110	135-150	120
Z7V	709, 711		B (NA) 6		88 x 73	2664	2	9,2	104	141	95
Z7W	701, 702, 709		B (NA) 6		91 x 73	2849	2		100-115	136-156	97
Z7W	700, 706, 707, 712, 713, 717		B (NA) 6		91 x 73	2849	2	9,5	110-115	150-156	97





R

				Pos					Pos
					1.3 (1300)	03.1972 → 10.1980	810.05	B	13
10 (119_)					16 (115_)				
1.1	05.1966 → 10.1972	688.01	B	7	1.6 TS (1151, 1154)	09.1968 → 08.1980	807.04	B	29
1.3	07.1969 → 10.1972	810.03	B	13	18 (134_)				
11 (B/C37_)					1.4	03.1983 → 10.1991	847 720	B	17
1.1 (B/C371)	03.1983 → 06.1986	C1E 715	B	7	1.4 (1340)	04.1978 → 07.1986	847 720	B	17
1.1 (B/C371)	03.1983 → 06.1986	C1E 720	B	7	1.4 (1340)	04.1978 → 07.1986	847 722	B	17
1.2 (B37S, C375)	10.1984 → 12.1988	C1G 700	B	8	1.6 (1341)	04.1978 → 09.1982	841 726	B	31
1.2 (B37S, C375)	10.1984 → 12.1988	C1G 710	B	8	2.0	09.1983 → 12.1986	J6R 716	B	95
1.3	01.1974 → 1980	810.10	B	13	2.0 (1343)	05.1982 → 07.1986	J6R 716	B	95
1.4	07.1986 → 10.1987	C2J 720	B	17	2.1 Diesel	11.1981 → 07.1986	J8S 711	D	89
1.4 (B/C372, B/C37C)	03.1983 → 12.1988	C1J 715	B	17	2.1 Diesel (1344)	11.1981 → 07.1986	852 710	D	89
1.4 (B/C372, B/C37C)	10.1986 → 12.1988	C2J 730	B	17	2.1 Diesel (1344)	11.1981 → 07.1986	J8S 711	D	89
1.4 (B/C373)	03.1983 → 12.1984	C2J 757	B	17	2.1 TD	11.1981 → 07.1986	J8S 712	D	89
1.4 (B/C373)	03.1983 → 12.1985	C2J 718	B	17	18 Variable (135_)				
1.4 (B/C373)	05.1983 → 12.1984	C2J 755	B	17	1.4	03.1983 → 10.1991	847 720	B	17
1.4 (B/C373)	05.1983 → 12.1985	C2J 717	B	17	1.4 (1350)	05.1979 → 07.1986	847 720	B	17
1.4 (B/C373, B/C37R)	10.1984 → 12.1988	C2J 766	B	17	1.4 (1350)	05.1979 → 07.1986	847 722	B	17
1.4 (B/C373, B/C37R)	10.1984 → 12.1988	C2J 767	B	17	1.6 (1351)	05.1979 → 09.1982	841 726	B	31
1.4 (B/C373, B/C37R)	10.1985 → 12.1988	C2J 768	B	17	2.0	09.1983 → 12.1986	J6R 716	B	95
1.4 (B/C373, B/C37R)	10.1986 → 11.1987	C2J 720	B	17	2.0 (1353)	05.1982 → 07.1986	J6R 716	B	95
1.4 Turbo	02.1984 → 06.1986	C1J 764	B	17	2.0 4x4	05.1983 → 07.1986	J6R 716	B	95
1.4 Turbo	05.1986 → 01.1989	C1J 760	B	17	2.0 4x4	05.1983 → 12.1986	J6R 714	B	95
1.4 Turbo (B/C375)	04.1984 → 12.1986	C1J 760	B	17	2.1 Diesel	05.1979 → 07.1986	J8S 711	D	89
1.4 Turbo (B/C375)	04.1984 → 12.1986	C1J 764	B	17	2.1 Diesel (1354)	11.1981 → 07.1986	852 710	D	89
1.4 Turbo (B/C375)	10.1986 → 12.1988	C1J 770	B	17	2.1 Diesel (1354)	11.1981 → 07.1986	J8S 711	D	89
1.4 Turbo (B/C375)	10.1986 → 12.1988	C1J 782	B	17	19 I (B/C53_)				
1.6 D (B/C374)	08.1983 → 12.1988	F8M 700	D	30	1.2	01.1988 → 12.1992	C1G 730	B	8
1.6 D (B/C374)	08.1983 → 12.1988	F8M 720	D	30	1.4	01.1988 → 12.1992	E6J 700	B	16
1.6 D (B/C374)	08.1983 → 12.1988	F8M 730	D	30	1.4	01.1988 → 12.1992	E6J 701	B	16
1.7 (B/C376)	10.1983 → 12.1987	F2N 700	B	56	1.4	09.1990 → 04.1992	E7J 700	B	16
1.7 (B/C376)	10.1983 → 12.1987	F2N 704	B	56	1.4 (B/C53P)	01.1989 → 12.1989	C2J 772	B	17
1.7 (B/C37D)	06.1987 → 12.1988	F2N 732	B	56	1.4 Cat (B/C532)	01.1989 → 04.1992	C3J 710	B	15
1.7 (B/C37D)	06.1987 → 12.1988	F2N 742	B	56	1.6i	01.1992 →	E7J 707	B	16
1.7 (B/C37E)	06.1987 → 12.1988	F3N 708	B	56	1.7	07.1988 → 04.1992	F2N 721	B	56
1.7 (B/C37F)	10.1984 → 12.1988	F3N 718	B	56	1.7	07.1988 → 04.1992	F2N 722	B	56
1.7 (B/C37L)	10.1986 → 12.1988	F2N 730	B	56	1.7	07.1988 → 04.1992	F2N 720	B	56
1.7 (B37N, C73N)	10.1986 → 12.1988	F2N 708	B	56	1.7	09.1988 → 04.1992	F2N 720	B	56
1.7 (B37N, C73N)	10.1986 → 12.1988	F2N 710	B	56	1.7	06.1989 → 04.1992	F3N 746	B	56
1.7 (B37N, C73N)	10.1986 → 12.1988	F2N 798	B	56	1.7 (B/C53B)	09.1988 → 04.1992	F3N 740	B	56
12					1.7 (B/C53B)	09.1988 → 04.1992	F3N 741	B	56
1.3	07.1973 → 03.1983	810.06	B	13	1.7 (B/C53C)	03.1989 → 04.1992	F3N 742	B	56
1.3 (1170)	01.1970 → 04.1980	810-02/97	B	13	1.7 (B/C53C)	03.1989 → 04.1992	F3N 743	B	56
1.3 (1170)	07.1975 → 04.1980	810.02	B	13	1.8	04.1994 → 09.1994	F3P 765	B	61
1.3 TS (1177, 1337)	08.1972 → 04.1980	810.06	B	13	1.8 16V	06.1989 → 04.1992	F7P 700	B	58
1.3 TS (1177, 1337)	08.1972 → 04.1980	810.05	B	13	1.8 16V (B/C53D)	06.1991 → 04.1992	F7P 704	B	59
1.4	08.1976 → 05.1979	C1J 791	B	17	1.9 D (B/C534, B/C53J)	09.1988 → 04.1992	F8Q 706	D	40
1.4	04.1983 → 12.1989	C1J 791	B	17	1.9 D (B/C534, B/C53J)	09.1990 → 04.1992	F8Q 742	D	42
1.4	05.1983 → 06.1989	C1J 791	B	17	1.9 DT	09.1990 → 04.1992	F8Q 610	D	40
1.4	01.1989 → 05.1995	C1J 791	B	17	1.9 DT	09.1990 → 04.1992	F8Q 740	D	40
12 Estate					19 I Cabriolet (D53_)				
1.4	04.1983 → 12.1989	C1J 791	B	17	1.7	07.1991 → 04.1992	F2N 724	B	56
1.4	05.1983 → 06.1989	C1J 791	B	17	1.7	07.1991 → 04.1992	F3N 742	B	56
1.4	01.1989 → 05.1995	C1J 791	B	17	1.7	07.1991 → 04.1992	F3N 742	B	56
12 TOROS Estate					1.7	07.1991 → 04.1992	F3N 743	B	56
1.4	04.1989 → 10.2000	C1J 791	B	17	1.8 16V (D53D)	07.1991 → 04.1992	F7P 700	B	58
12 TOROS Saloon					1.8 16V (D53D)	07.1991 → 04.1992	F7P 704	B	59
1.4	04.1989 → 10.2000	C1J 791	B	17	19 I Chamade (L53_)				
12 Variable (117_)					1.1 TR	07.1988 → 04.1992	C1E 700	B	7
1.3	08.1982 → 03.1983	810.06	B	13	1.2	01.1988 → 12.1992	C1G 730	B	8
1.3 (1170)	10.1970 → 04.1980	810-02/97	B	13	1.4	07.1988 → 08.1990	E6J 700	B	16
1.3 (1170)	07.1975 → 04.1980	810.02	B	13	1.4	07.1988 → 08.1990	E6J 701	B	16
1.3 (1177)	08.1973 → 04.1980	810.06	B	13	1.4	06.1989 → 08.1990	E6J 700	B	16
1.3 (1177)	08.1973 → 08.1980	810.05	B	13	1.4	09.1990 → 04.1992	E7J 700	B	16
1.4	08.1976 → 08.1980	C1J 791	B	17	1.4 (L532, L53P)	07.1988 → 04.1992	C2J 772	B	17
14 (121_)					1.4 (L532, L53P)	07.1988 → 04.1992	C3J 710	B	15
1.3	01.1972 →	810.10	B	13	1.7	09.1990 → 04.1992	F2N 721	B	56
15 (130_)					1.7 (L533)	09.1988 → 12.1992	F2N 720	B	56
					1.7 (L533)	09.1988 → 12.1992	F2N 721	B	56

				Pos					Pos
1.7 (L53B)	10.1989 → 04.1992	F3N 740	B	56	1.7	05.1992 → 11.1995	F3N 740	B	56
1.7 (L53B)	10.1989 → 04.1992	F3N 741	B	56	1.7	05.1992 → 11.1995	F3N 741	B	56
1.7 (L53C)	10.1989 → 04.1992	F3N 742	B	56	1.7 (L533)	01.1993 → 08.1995	F2N 720	B	56
1.7 (L53C)	10.1989 → 04.1992	F3N 743	B	56	1.7 (L533)	01.1993 → 08.1995	F2N 721	B	56
1.7 (L53F)	08.1988 → 12.1992	F3N 746	B	56	1.7 (L53B)	04.1992 → 06.1995	F3N 740	B	56
1.8 16V	06.1989 → 08.1990	F7P 700	B	58	1.7 (L53B)	04.1992 → 06.1995	F3N 741	B	56
1.8 16V (L53D)	06.1991 → 04.1992	F7P 704	B	59	1.7 (L53C)	04.1992 → 12.1995	F3N 742	B	56
1.9 D (L534, L53J)	10.1989 → 04.1992	F8Q 706	D	40	1.7 (L53C)	04.1992 → 12.1995	F3N 743	B	56
1.9 D (L534, L53J)	09.1990 → 04.1992	F8Q 742	D	42	1.8	05.1992 → 11.1995	F3P 700	B	61
1.9 DT	09.1990 → 04.1992	F8Q 740	D	40	1.8	09.1992 → 11.1995	F3P 706	B	61
1.9 TD (L53K)	09.1990 → 04.1992	F8Q 740	D	40	1.8	04.1994 → 09.1994	F3P 765	B	61
<b>19 II (B/C53 )</b>					1.8 (453A/F)	09.1992 → 12.1995	F3P 706	B	61
1.2	04.1992 → 12.1995	C1G 730	B	8	1.8 (453A/F)	09.1992 → 12.1995	F3P 760	B	61
1.2	05.1992 → 09.1994	E7F 730	B	16	1.8 (L538)	04.1992 → 05.1994	F3P 700	B	61
1.4	01.1992 → 12.1995	E6J 700	B	16	1.8 (L53V, L538)	05.1994 → 12.1995	F3P 682	B	61
1.4	01.1992 → 12.1995	E7J 706	B	16	1.8 (L53Y)	04.1992 → 01.1993	F3P 704	B	61
1.4	05.1993 → 12.1998	E6J 700	B	16	1.8 (L53Y)	04.1992 → 01.1993	F3P 705	B	61
1.4	10.1996 → 06.2001	E6J 706	B	16	1.8 (L53Y)	04.1992 → 01.1993	F3P 707	B	61
1.4	10.1998 → 06.2001	K4J 718	B	35	1.8 (L53Y)	09.1992 → 12.1995	F3P 706	B	61
1.4 (B/C532)	04.1992 → 12.1995	C3J 710	B	15	1.8 (L53Y)	09.1992 → 12.1995	F3P 760	B	61
1.4 (B/C535)	09.1994 → 12.1995	E7J 742	B	16	1.8 (L53Y)	01.1993 → 12.1995	F3P 708	B	61
1.6	07.1998 → 06.2001	K4M 744	B	33	1.8 16V (L53D)	04.1992 → 12.1995	F7P 704	B	59
1.7	05.1992 → 09.1994	F3N 746	B	56	1.9 D	05.1992 → 11.1995	F8Q 740	D	40
1.7 (B/C53B)	04.1992 → 06.1995	F3N 740	B	56	1.9 D	05.1992 → 11.1995	F8Q 744	D	40
1.7 (B/C53B)	04.1992 → 06.1995	F3N 741	B	56	1.9 D (L53J)	04.1992 → 12.1995	F8Q 742	D	42
1.7 (B/C53C)	04.1992 → 12.1995	F3N 743	B	56	1.9 dT (L53T)	04.1992 → 12.1995	F8Q 744	D	40
1.8	02.1995 → 05.1998	F3P 700	B	61	<b>20 (127 )</b>				
1.8 (5/353A)	09.1992 → 12.1995	F3P 706	B	61	1.6 (1271)	10.1975 → 05.1977	843.20	B	31
1.8 (5/353A)	09.1992 → 12.1995	F3P 760	B	61	1.6 (1271)	10.1975 → 05.1977	843.21	B	31
1.8 (5/353F, B/C538)	05.1994 → 12.1995	F3P 682	B	61	1.9 D	10.1980 → 12.1983	F8Q 704	D	40
1.8 (5/353F, B/C538)	05.1994 → 12.1995	F3P 765	B	61	2.1 TD	01.1982 → 12.1983	J8S 702	D	89
1.8 (B/C538)	04.1992 → 05.1994	F3P 700	B	61	<b>21 (B48 )</b>				
1.8 (B/C53Y)	04.1992 → 01.1993	F3P 707	B	61	1.4 (B48D)	09.1989 → 05.1993	C2J 770	B	17
1.8 (B/C53Y)	09.1992 → 12.1995	F3P 706	B	61	1.7	07.1989 → 05.1993	F2N 711	B	56
1.8 (B/C53Y)	09.1992 → 12.1995	F3P 760	B	61	1.7	07.1989 → 05.1993	F2N 712	B	56
1.8 (B/C53Y)	01.1993 → 12.1995	F3P 708	B	61	1.7	07.1989 → 05.1993	F2N 754	B	56
1.8 16V	10.1994 → 12.1997	F7P 700	B	58	1.7	07.1989 → 05.1993	F3N 726	B	56
1.8 16V (B/C53D)	04.1992 → 12.1995	F7P 704	B	59	1.7 (B48E)	09.1989 → 12.1993	F3N 722	B	56
1.9 D (B/C53J)	04.1992 → 12.1995	F8Q 742	D	42	1.7 (B48E)	09.1989 → 12.1993	F3N 723	B	56
1.9 dT (B/C53T)	04.1992 → 12.1995	F8Q 744	D	40	1.7 (B48F)	09.1989 → 10.1992	F3N 726	B	56
<b>19 II Cabriolet (D53 , 853 )</b>					1.9 D (B48H, B48I)	09.1989 → 01.1994	F8Q 710	D	40
1.7 (D53C)	04.1992 → 09.1993	F3N 742	B	56	1.9 TD	05.1989 → 12.1994	F8Q 784	D	41
1.7 (D53C)	04.1992 → 09.1993	F3N 743	B	56	2.0	07.1989 → 06.1992	J7R 750	B	95
1.8 (853A)	09.1993 → 06.1996	F3P 706	B	61	2.0	07.1989 → 06.1992	J7R 751	B	95
1.8 (853A)	09.1993 → 06.1996	F3P 760	B	61	2.0 (B48C)	09.1989 → 12.1993	J7R 746	B	95
1.8 (D53V, 853F, D53C)	07.1994 → 06.1996	F3P 682	B	61	2.0 (B48C)	09.1989 → 12.1993	J7R 747	B	95
1.8 (D53V, 853F, D53C)	07.1994 → 06.1996	F3P 764	B	61	2.0 (B48R/Y)	02.1990 → 10.1992	J7R 740	B	95
1.8 (D53V, 853F, D53C)	07.1994 → 06.1996	F3P 765	B	61	2.0 4x4 (B48R/Y)	09.1990 → 10.1992	J7R 740	B	95
1.8 (D53Y)	04.1992 → 01.1993	F3P 707	B	61	2.0 TXi	07.1989 → 05.1993	J7R 740	B	95
1.8 (D53Y)	04.1992 → 01.1996	F3P 706	B	61	2.0 TXi	07.1989 → 05.1993	J7R 754	B	95
1.8 (D53Y)	04.1992 → 01.1996	F3P 707	B	61	2.1 D	07.1989 → 05.1993	J8S 704	D	89
1.8 (D53Y)	04.1992 → 06.1996	F3P 704	B	61	2.1 D	07.1989 → 05.1993	J8S 784	D	89
1.8 (D53Y)	04.1992 → 06.1996	F3P 705	B	61	2.1 D (B480)	04.1992 → 06.1994	J8S 784	D	89
1.8 (D53Y)	04.1992 → 06.1996	F3P 706	B	61	2.1 D (B48V/B48O)	09.1989 → 12.1992	J8S 600	D	89
1.8 (D53Y)	01.1993 → 06.1996	F3P 708	B	61	2.1 D (B48V/B48O)	09.1989 → 12.1992	J8S 740	D	89
1.8 (D53Y)	01.1993 → 06.1996	F3P 760	B	61	2.1 Turbo-D (B486, B488, B48V)	09.1989 → 12.1993	J8S 714	D	89
1.8 16V	05.1992 → 04.1994	F7P 704	B	59	2.1 Turbo-D (B486, B488, B48V)	09.1989 → 12.1993	J8S 788	D	89
1.8 16V (D53D)	04.1992 → 06.1996	F7P 704	B	59	2.1 Turbo-D (B486, B488, B48V)	08.1991 → 06.1994	J8S 786	D	89
<b>19 II Chamade (L53 )</b>					2.2	07.1989 → 05.1993	J7T 755	B	95
1.2	05.1992 → 09.1994	E7F 730	B	16	2.2	03.1992 → 06.1994	J7T 755	B	95
1.4	05.1992 → 09.1994	C1J 742	B	17	2.2 (B48K)	09.1989 → 06.1994	J7T 754	B	95
1.4	05.1992 → 09.1994	C2J 772	B	17	2.2 (B48K)	09.1989 → 06.1994	J7T 755	B	95
1.4	05.1992 → 09.1994	C3J 710	B	15	2.2 4x4 (B48K)	07.1990 → 12.1993	J7T 754	B	95
1.4	10.1994 → 11.1995	E6J 700	B	16	2.2 4x4 (B48K)	07.1990 → 12.1993	J7T 755	B	95
1.4	10.1994 → 11.1995	E7J 706	B	16	<b>21 Estate (K48 )</b>				
1.4	10.1998 → 06.2001	K4J 715	B	34	1.7 (K/S481)	06.1986 → 12.1987	F2N 712	B	56
1.4 (532)	04.1992 → 12.1995	C3J 710	B	15					
1.4 (L535)	09.1994 → 12.1995	E7J 742	B	16					
1.6	10.1996 → 06.2001	K7M 703	B	32					

R



		Pos			Pos					
1.7 (K/S482)	10.1986 → 12.1988	F2N 710	B	56	2.0 Turbo 4x4	08.1989 → 03.1990	J7R 752	B	95	
1.7 (K48E)	06.1986 → 12.1989	F3N 722	B	56	2.0 Turbo 4x4 (L48L)	02.1990 → 10.1992	J7R 756	B	95	
1.7 (K48E)	06.1986 → 12.1989	F3N 723	B	56	2.1 D (L480)	10.1992 → 06.1994	J8S 784	D	89	
1.7 (K48E)	10.1989 → 12.1993	F3N 722	B	56	2.1 D (L486)	03.1986 → 12.1989	J8S 704	D	89	
1.7 (K48E)	10.1989 → 12.1993	F3N 723	B	56	2.1 D (L48V, L48O)	05.1989 → 06.1994	J8S 600	D	89	
1.7 (K48M)	07.1986 → 12.1989	F2N 750	B	56	2.1 D (L48V, L48O)	08.1989 → 12.1992	J8S 740	D	89	
1.7 (K48N)	06.1987 → 04.1989	F2N 752	B	56	2.1 TD	04.1986 → 06.1989	J8S 704	D	89	
1.7 Cat (K48F)	07.1989 → 06.1993	F3N 726	B	56	2.1 Turbo-D (L48A, L48W, L487, L488)	03.1986 → 12.1993	J8S 714	D	89	
1.9 D	03.1986 → 08.1994	F8Q 710	D	40	2.1 Turbo-D (L48A, L48W, L487, L488)	03.1986 → 12.1993	J8S 788	D	89	
2.0	07.1989 → 06.1992	J7R 750	B	95	2.1 Turbo-D (L48A, L48W, L487, L488)	08.1991 → 06.1994	J8S 786	D	89	
2.0	07.1989 → 06.1992	J7R 751	B	95	2.2	04.1986 → 06.1989	J7T 755	B	95	
2.0	06.1991 → 05.1993	J6R 758	B	95	2.2	06.1986 → 07.1997	J7T 755	B	95	
2.0	06.1991 → 05.1993	J6R 759	B	95	2.2	03.1992 → 07.1997	J7T 730	B	95	
2.0	06.1991 → 05.1993	J6R 792	B	95	2.2	03.1992 → 07.1997	J7T 731	B	95	
2.0 (K483)	06.1986 → 12.1988	J7R 750	B	95	2.2 (L48K)	08.1986 → 12.1993	J7T 754	B	95	
2.0 (K483)	06.1986 → 12.1988	J7R 751	B	95	2.2 (L48K)	08.1986 → 12.1993	J7T 755	B	95	
2.0 (K48C)	03.1986 → 12.1993	J7R 746	B	95	2.2 4x4 (L48K)	07.1990 → 12.1993	J7T 754	B	95	
2.0 (K48C)	03.1986 → 12.1993	J7R 747	B	95	2.2 4x4 (L48K)	07.1990 → 12.1993	J7T 755	B	95	
2.0 (K48R)	06.1990 → 02.1994	J7R 740	B	95	<b>25 (B29_)</b>					
2.0 4x4	03.1989 → 12.1993	J7R 746	B	95	2.0	03.1987 → 12.1993	J7R 722	B	95	
2.0 4x4	03.1989 → 12.1993	J7R 747	B	95	2.0	03.1987 → 12.1993	J7R 723	B	95	
2.1 D (K/S486)	10.1986 → 09.1990	J8S 704	D	89	2.0 (B297)	04.1984 → 12.1989	J6R 706	B	95	
2.1 D (K/S48V, K/S48O)	08.1989 → 12.1992	J8S 600	D	89	2.0 (B297)	04.1984 → 12.1989	J6R 707	B	95	
2.1 D (K/S48V, K/S48O)	08.1989 → 12.1992	J8S 740	D	89	2.0 (B297)	04.1984 → 12.1989	J6R 760	B	95	
2.1 D (K480)	04.1992 → 09.1995	J8S 784	D	89	2.0 (B297)	04.1984 → 12.1989	J6R 762	B	95	
2.1 D 4x4 (K486)	10.1988 → 05.1992	J8S 704	D	89	2.0 (B297)	04.1984 → 12.1989	J6R 763	B	95	
2.1 Turbo-D (K48A, K48W, K487, K488)	10.1986 → 11.1993	J8S 714	D	89	2.0 12V	06.1988 → 12.1993	J7R 720	B	95	
2.1 Turbo-D (K48A, K48W, K487, K488)	10.1986 → 11.1993	J8S 788	D	89	2.0 12V	06.1988 → 12.1993	J7R 721	B	95	
2.1 Turbo-D (K48A, K48W, K487, K488)	04.1992 → 11.1993	J8S 786	D	89	2.0 12V (B294)	06.1989 → 12.1992	J7R 726	B	95	
2.2	03.1992 → 07.1997	J7T 755	B	95	2.1 Diesel (B296)	04.1984 → 05.1989	J8S 706	D	89	
2.2 (K48K)	08.1986 → 11.1993	J7T 754	B	95	2.1 Diesel (B296)	06.1989 → 12.1992	J8S 736	D	89	
2.2 (K48K)	08.1986 → 11.1993	J7T 755	B	95	2.1 Turbo-D FWD (B290, B29W)	04.1984 → 12.1992	J8S 708	D	89	
2.2 4x4 (K48K)	08.1986 → 12.1993	J7T 754	B	95	2.1 Turbo-D FWD (B290, B29W)	02.1990 → 07.1991	J8S 738	D	89	
2.2 4x4 (K48K)	08.1986 → 12.1993	J7T 755	B	95	<b>21 Saloon (L48_)</b>					
<b>21 Saloon (L48_)</b>						2.2 (B29)	11.1985 → 03.1989	J7T 708	B	95
1.4 (L48D)	06.1988 → 10.1993	C2J 770	B	17	2.2 (B29)	11.1985 → 03.1989	J7T 732	B	95	
1.7	04.1986 → 06.1989	F3N 722	B	56	2.2 (B29B)	09.1986 → 12.1992	J7T 708	B	95	
1.7	04.1986 → 06.1989	F3N 723	B	56	2.2 (B29B)	09.1986 → 12.1992	J7T 732	B	95	
1.7 (L481)	03.1986 → 12.1987	F2N 712	B	56	2.2 (B29B)	09.1986 → 12.1992	J7T 733	B	95	
1.7 (L482)	06.1986 → 03.1992	F2N 710	B	56	2.2 (B29E)	04.1984 → 12.1989	J7T 706	B	95	
1.7 (L48E)	06.1986 → 12.1993	F3N 722	B	56	2.2 (B29E)	04.1984 → 12.1989	J7T 707	B	95	
1.7 (L48E)	06.1986 → 12.1993	F3N 723	B	56	2.2 (B29E)	04.1984 → 12.1989	J7T 714	B	95	
1.7 (L48E)	09.1989 → 12.1993	F3N 722	B	56	2.2 (B29E)	04.1984 → 12.1989	J7T 715	B	95	
1.7 (L48E)	09.1989 → 12.1993	F3N 723	B	56	2.2 (B29E)	04.1984 → 12.1989	J7T 730	B	95	
1.7 (L48M, L48F)	07.1986 → 12.1989	F2N 750	B	56	2.2 (B29E)	04.1984 → 12.1989	J7T 731	B	95	
1.7 (L48M, L48F)	07.1989 → 02.1994	F3N 726	B	56	2.7 V6 Injection (B298)	04.1984 → 08.1989	Z7V 709	B	95	
1.7 (L48N)	06.1987 → 04.1989	F2N 752	B	56	2.7 V6 Injection (B298)	04.1984 → 08.1989	Z7V 711	B	95	
1.9 D (L48H, L48I)	08.1989 → 10.1993	F8Q 710	D	40	2.8 V6 (B293)	06.1987 → 02.1990	Z7W 700	B	97	
2.0	04.1986 → 06.1989	J7R 750	B	95	2.8 V6 Injection (B29A)	06.1986 → 02.1988	Z7W 702	B	97	
2.0	04.1986 → 06.1989	J7R 751	B	95	2.8 V6 Injection (B29F)	06.1987 → 12.1992	Z7W 706	B	97	
2.0	04.1988 → 06.1989	J6R 792	B	95	2.8 V6 Injection (B29F)	06.1987 → 12.1992	Z7W 707	B	97	
2.0	04.1988 → 06.1989	J6R 793	B	95	2.8 V6 Injection (B29F)	06.1989 → 12.1992	Z7W 709	B	97	
2.0	05.1991 → 10.1993	J6R 758	B	95	<b>30 (127_)</b>					
2.0 (L483)	03.1986 → 12.1988	J7R 750	B	95	2.1 Turbo-D (1270)	02.1982 → 03.1986	J8S 702	D	89	
2.0 (L483)	03.1986 → 12.1988	J7R 751	B	95	2.6 (1273)	02.1975 → 07.1976	112	B	95	
2.0 (L489)	03.1986 → 10.1993	J6R 758	B	95	2.6 (1273)	08.1976 → 08.1978	112	B	95	
2.0 (L489)	03.1986 → 10.1993	J6R 759	B	95	2.6 TX (1278)	10.1978 → 12.1983	140	B	95	
2.0 (L489)	03.1986 → 10.1993	J6R 792	B	95	2.7i	10.1978 → 12.1983	140	B	95	
2.0 (L489)	03.1986 → 10.1993	J6R 793	B	95	<b>4 (112_)</b>					
2.0 (L48C)	03.1986 → 12.1993	J7R 746	B	95	1.1	06.1986 → 06.1990	C1E 714	B	7	
2.0 (L48C)	03.1986 → 12.1993	J7R 747	B	95	1.1 (1128, S128)	06.1978 → 06.1990	C1E 714	B	7	
2.0 (L48R)	02.1990 → 02.1994	J7R 740	B	95	1.1 (1128, S128)	06.1978 → 06.1990	C1E 719	B	7	
2.0 4x4 (L48R)	02.1990 → 02.1994	J7R 740	B	95	<b>5 (122_)</b>					
2.0 TXi 4x4	08.1989 → 08.1994	J7R 754	B	95	1.1 (1227, 1397)	01.1981 → 12.1985	C1E 726	B	7	
2.0 Turbo (L485)	04.1987 → 03.1990	J7R 752	B	95	1.3 (1224, 1394)	09.1975 → 09.1984	810 725	B	13	
2.0 Turbo (L48L)	02.1990 → 10.1992	J7R 756	B	95	1.3 (1225)	09.1976 → 09.1979	810 726	B	13	

R



			Pos				Pos		
1.3 (1225, 1395)	06.1979 → 09.1984	810 719	B	13	1.5 dCi (J5MW)	06.2013 →	K9K 830	D	25
1.3 Automatik (1225, 1395)	06.1979 → 09.1984	810 729	B	13	1.5 dCi 110	01.2015 →	K9K 646	D	21
1.4 (1229, 1399)	01.1982 → 12.1985	C2J 713	B	17	1.5 dCi 110	01.2015 →	K9K 856	D	25
1.7i	10.1986 → 12.1996	F3N 702	B	56	1.5 dCi 90	06.2013 →	K9K 608	D	21
1.7i	10.1986 → 12.1996	F3N 716	B	56	1.5 dCi 90	06.2013 →	K9K 609	D	21
1.7i	10.1986 → 12.1996	F3N 717	B	56	1.5 dCi 90	06.2013 →	K9K 628	D	21
1.7i	10.1986 → 12.1996	F3N 718	B	56	1.5 dCi 90	06.2013 →	K9K 629	D	21
1.7i	10.1986 → 12.1996	F3N 722	B	56	1.5 dCi 90	06.2013 →	K9K 838	D	21
<b>6 (118_)</b>					2.0	07.2017 →	F4R 410	B	68
1.1	08.1970 → 04.1987	688.10	B	7	2.0 (H5AA)	12.2016 →	F4R 410	B	68
1.1	07.1971 → 04.1980	688.10	B	7	2.0 (H5AA)	12.2016 →	F4R 412	AB	71
<b>7 (124_)</b>					2.0 Flex (H5AA)	01.2017 → 12.2020	F4R 410	B	68
1.1	09.1980 → 12.1982	688 13	B	7	2.0 Flex (H5AA)	01.2017 → 12.2020	F4R 412	AB	71
<b>8 (113_)</b>					<b>CAPTUR II</b>				
1.1	11.1962 → 10.1972	688.01	B	7	Blue dCi 115 (HFAD)	01.2020 →	K9K 872	D	25
<b>9 (L42_)</b>					Blue dCi 115 (HFAD)	01.2020 →	K9K 873	D	21
1.1 (L421)	09.1981 → 06.1986	C1E 715	B	7	Blue dCi 95 (HFAF)	01.2020 →	K9K 872	D	25
1.1 (L421)	09.1981 → 06.1986	C1E 720	B	7	<b>CLIO I (B/C57_, 5/357_)</b>				
1.2 (L42S)	09.1985 → 12.1988	C1G 700	B	8	1.1	01.1991 → 09.1998	C1E 700	B	7
1.2 (L42S)	09.1985 → 12.1988	C1G 710	B	8	1.1	04.1992 → 08.1992	C1E 700	B	7
1.4	07.1986 → 10.1987	C2J 720	B	17	1.2 (5/357Y, 5/357K)	01.1996 → 09.1998	D7F 730	B	4
1.4 (L422, L42C)	12.1981 → 12.1988	C1J 715	B	17	1.2 (5/357Y, 5/357K)	01.1996 → 09.1998	D7F 730	B	4
1.4 (L422, L42C)	12.1981 → 12.1988	C1J 792	B	17	1.2 (B/C/S572)	05.1990 → 03.1996	E5F 710	B	16
1.4 (L422, L42C)	12.1981 → 12.1988	C1J 796	B	17	1.2 (B/C/S577)	01.1996 → 12.1996	C3G 720	B	14
1.4 (L422, L42C)	10.1986 → 12.1988	C2J 730	B	17	1.2 (B/C/S57A, B/C57S, 5/357F, 5/357J, 5/357L, 5/357R)	05.1990 → 09.1998	E7F 700	B	16
1.4 (L423)	10.1982 → 12.1984	C2J 755	B	17	1.2 (B/C/S57A, B/C57S, 5/357F, 5/357J, 5/357L, 5/357R)	05.1990 → 09.1998	E7F 708	B	16
1.4 (L423)	03.1983 → 12.1985	C2J 717	B	17	1.2 (B/C/S57A, B/C57S, 5/357F, 5/357J, 5/357L, 5/357R)	01.1994 → 09.1998	E7F 750	B	16
1.4 (L423, L42R)	09.1985 → 12.1988	C2J 766	B	17	1.2 (B/C/S57A, B/C57S, 5/357F, 5/357J, 5/357L, 5/357R)	01.1991 → 06.1996	E7F 706	B	16
1.4 (L423, L42R)	09.1985 → 12.1988	C2J 767	B	17	1.4	05.1990 → 02.1998	E6J 712	B	16
1.4 (L423, L42R)	10.1985 → 12.1988	C2J 768	B	17	1.4	05.1990 → 02.1998	E6J 713	B	16
1.4 (L423, L42R)	10.1986 → 11.1987	C2J 720	B	17	1.4	05.1990 → 02.1998	E6J 760	B	16
1.4 Automatik (L423)	10.1982 → 12.1984	C2J 757	B	17	1.4	01.1991 → 09.1998	E7J 710	B	16
1.4 Automatik (L423)	03.1983 → 12.1985	C2J 718	B	17	1.4	01.1991 → 09.1998	E7J 711	B	16
1.4 Turbo	07.1986 → 12.1989	C1J 764	B	17	1.4	01.1991 → 09.1998	E7J 711	B	16
1.4 Turbo	12.1986 → 12.1986	C1J 764	B	17	1.4 (B/C57T, B/C57Y)	01.1991 → 09.1998	E7J 601	B	16
1.4 Turbo (L425)	04.1984 → 12.1986	C1J 760	B	17	1.4 (B/C57T, B/C57Y)	01.1991 → 09.1998	E7J 718	B	16
1.4 Turbo (L425)	04.1984 → 12.1986	C1J 764	B	17	1.4 (B/C57T, B/C57Y)	01.1991 → 09.1998	E7J 719	B	16
1.6 D (L424)	10.1982 → 12.1988	F8M 700	D	30	1.4 (B/C57T, B/C57Y)	03.1994 → 09.1998	E7J 754	B	16
1.6 D (L424)	10.1982 → 12.1988	F8M 720	D	30	1.4 (B57J, C57J, B57P)	01.1991 → 09.1998	E6J 718	B	16
1.6 D (L424)	10.1982 → 12.1988	F8M 730	D	30	1.4 (B57J, C57J, B57P)	01.1991 → 09.1998	E7J 756	B	16
1.7 (L426)	09.1984 → 12.1987	F2N 700	B	56	1.4 (B57J, C57J, B57P)	01.1991 → 09.1998	E7J 757	B	16
1.7 (L426)	09.1984 → 12.1987	F2N 704	B	56	1.7 (B/C574)	01.1991 → 12.1993	F2N 770	B	56
1.7 (L42E)	06.1987 → 12.1988	F3N 708	B	56	1.8	08.1990 → 04.1996	F3P 755	B	60
1.7 (L42F)	10.1986 → 12.1988	F3N 718	B	56	1.8	01.1991 → 09.1998	F3P 710	B	61
1.7 (L42L)	10.1986 → 12.1988	F2N 730	B	56	1.8 (B/C578)	08.1994 → 09.1998	F3P 754	B	60
1.7 (L42N)	10.1986 → 12.1988	F2N 708	B	56	1.8 (B/C578)	08.1994 → 09.1998	F3P 755	B	60
1.7 (L42N)	10.1986 → 12.1988	F2N 710	B	56	1.8 (B/C57C, B/C57U)	01.1991 → 09.1998	F3P 710	B	61
1.7 (L42N)	10.1986 → 12.1988	F2N 798	B	56	1.8 (B/C57C, B/C57U)	01.1991 → 09.1998	F3P 714	B	61
<b>ALASKAN</b>					1.8 16V (C57D)	08.1991 → 06.1994	F7P 722	B	58
2.3 dCi 163 4x4 (U3MB)	09.2017 →	M9T 260	D	87	1.8 Rsi (B/C579)	01.1993 → 08.1995	F3P 712	B	61
2.3 dCi 190 4x4 (U3MD)	09.2017 →	M9T 260	D	87	1.8 Rsi (B/C57H)	08.1995 → 09.1998	F3P 758	B	60
<b>ALLIANCE Saloon</b>					1.9 D	05.1996 → 02.1998	F8Q 632	D	45
1.7	09.1983 → 12.1986	F2N 730	B	56	1.9 D	05.1996 → 02.1998	F8Q 676	D	42
<b>AVANTIME (DE0_)</b>					1.9 D	05.1996 → 02.1998	F8Q 696	D	42
1.9 dTi	09.2001 → 12.2003	F9Q 722	D	48	1.9 D	05.1996 → 02.1998	F8Q 714	D	42
2.0 16V Turbo (DE0U, DE0V)	11.2001 → 05.2003	F4R 760	B	65	1.9 D	01.1997 → 09.1998	F8Q 678	D	42
2.0 16V Turbo (DE0U, DE0V)	11.2001 → 05.2003	F4R 761	B	65	1.9 D (B/C/S576, B/C/S57L)	01.1991 → 12.1993	F8Q 730	D	42
2.2 dCi (DE01)	05.2002 → 05.2003	G9T 712	D	94	1.9 D (B/C/S576, B/C/S57L)	01.1991 → 09.1998	F8Q 732	D	42
<b>CAPTUR I (J5_, H5_)</b>					Williams	10.1994 → 04.1996	F7R 700	B	62
0.9 TCe 90	06.2013 →	H4B 400	B	11	Williams (B/C57M)	01.1994 → 09.1998	F7R 700	B	62
1.2 T	06.2013 →	H5F 403	B	10	<b>CLIO II</b>				
1.2 T	06.2015 →	H5F 403	B	10	1.0i 16V	06.2001 → 11.2004	D4D 700	B	5
1.2 TCe (J5AU)	02.2018 →	H5F 408	B	10	1.0i 16V	06.2001 → 11.2004	D4D 706	B	5
1.2 TCe 120	06.2013 →	H5F 403	B	10					
1.2 TCe 120	01.2016 →	H5F 408	B	10					
1.2 TCe 120	01.2016 →	H5F 412	B	10					

R

		Pos			Pos
1.0i 16V 06.2001 → 11.2004	D4D 712 B	5	1.6 16V (BB01, BB0H, BB0T, BB14, BB1D, BB1R, BB2KL, BB3G...	K4M 708 B	33
1.0i 16V 06.2001 → 11.2004	D4D 720 B	5			
1.0i 16V 06.2001 → 11.2004	D4D 752 B	5			
<b>CLIO II (BB, CB)</b>			1.6 16V (BB01, BB0H, BB0T, BB14, BB1D, BB1R, BB2KL, BB3G...	K4M 740 B	33
1.0 Campus Flex (CB32, CB3B, CB3V, CB3W, BB32, BB3B,...	D4D 754 B	5			
1.0 Flex (CB32, CB3B, CB3V, CB3W, BB32, BB3B, BB3V,...	D4D 754 B	5			
1.2 (BB0A, BB0F, BB10, BB1K, BB28, BB2D, BB2H, CB0A,...	D7F 710 B	4			
1.2 (BB0A, BB0F, BB10, BB1K, BB28, BB2D, BB2H, CB0A,...	D7F 720 B	4			
1.2 (BB0A, BB0F, BB10, BB1K, BB28, BB2D, BB2H, CB0A,...	D7F 722 B	4			
1.2 (BB0A, BB0F, BB10, BB1K, BB28, BB2D, BB2H, CB0A,...	D7F 726 B	4			
1.2 (BB0A, BB0F, BB10, BB1K, BB28, BB2D, BB2H, CB0A,...	D7F 746 B	4	1.6 Authentique Hi-Flex 11.2004 → 02.2009	K4M 748 AB	38
1.2 16V (BB05, BB0W, BB11, BB27, BB2T, BB2U, BB2V, CB05,...	D4F 706 B	5	1.6 Flex 05.2000 → 12.2006	K4M 740 B	33
1.2 16V (BB05, BB0W, BB11, BB27, BB2T, BB2U, BB2V, CB05,...	D4F 712 B	5	1.6 Flex 05.2000 → 12.2006	K4M 748 AB	38
1.2 16V (BB05, BB0W, BB11, BB27, BB2T, BB2U, BB2V, CB05,...	D4F 714 B	5	1.6 Hi-Flex (CB0H) 01.2005 → 02.2010	K4M 748 AB	38
1.2 16V (BB05, BB0W, BB11, BB27, BB2T, BB2U, BB2V, CB05,...	D4F 722 B	5	1.9 D (B/CB0E) 09.1998 → 05.2005	F8Q 630 D	47
1.2 16V (BB05, BB0W, BB11, BB27, BB2T, BB2U, BB2V, CB05,...	D4F 728 B	5	1.9 D (B/CB0J) 02.2000 → 05.2001	F8Q 630 D	47
1.2 LPG 09.1998 → 06.2009	D7F 764 B	4	1.9 D (B/CB0J) 02.2000 → 05.2001	F8Q 632 D	45
1.2 LPG 09.1998 → 06.2009	D7F 766 B	4	1.9 dTi (B/CB0U) 12.1999 → 05.2005	F9Q 780 D	50
1.2 LPG (BB0A, CB0A) 03.1999 → 05.2001	D7F 722 B	4	1.9 dTi (B/CB0U) 12.1999 → 05.2005	F9Q 782 D	50
1.4 (B/CB0C, B/CB0S) 09.1998 → 05.2005	E7J 634 B	16	2.0 16V 06.2001 → 05.2005	F4R 730 B	65
1.4 (B/CB0C, B/CB0S) 09.1998 → 05.2005	E7J 635 B	16	2.0 16V 06.2001 → 05.2005	F4R 736 B	65
1.4 (B/CB0C, B/CB0S) 09.1998 → 05.2005	E7J 780 B	16	2.0 16V Sport 01.2004 → 04.2005	F4R 738 B	65
1.4 (B/CB0C, B/CB0S) 09.1998 → 05.2005	K7J 700 B	16	2.0 16V Sport (CB0M) 02.2000 → 06.2009	F4R 730 B	65
1.4 16V (B/CB0L) 10.1999 → 09.2004	K4J 712 B	33	2.0 16V Sport (CB0M) 02.2000 → 06.2009	F4R 736 B	65
1.4 16V (B/CB0L) 10.1999 → 09.2004	K4J 713 B	33	<b>CLIO III</b>		
1.4 16V (B/CB0P, BB13) 02.2000 → 07.2008	K4J 710 B	33	1.2i Turbo 16V 06.2005 →	D4F 780 B	5
1.4 16V (B/CB0P, BB13) 02.2000 → 07.2008	K4J 711 B	33	1.9 dCi 06.2005 →	F9Q 670 D	49
1.4 16V (B/CB0P, BB13) 02.2000 → 07.2008	K4J 712 B	33	1.9 dCi 06.2005 →	F9Q 674 D	49
1.4 16V (B/CB0P, BB13) 02.2000 → 07.2008	K4J 713 B	33	<b>CLIO III (BR0/1, CR0/1)</b>		
1.4 16V (B/CB0P, BB13) 02.2000 → 07.2008	K4J 715 B	34	1.2 (BR01, BR03, BR0E, CR0E) 10.2005 → 12.2012	D4F 764 B	5
1.5 dCi 06.2001 → 12.2006	K9K 704 D	18	1.2 16V 06.2005 → 12.2014	D4F 764 B	5
1.5 dCi 10.2003 → 04.2005	K9K 712 D	18	1.2 16V 06.2006 → 08.2010	D4F 764 B	5
1.5 dCi (B/C2J) 08.2004 → 12.2012	K9K 700 D	18	1.2 16V 09.2010 → 12.2014	D4F 786 B	5
1.5 dCi (B/C2J) 08.2004 → 12.2012	K9K 714 D	18	1.2 16V (BR02, BR0J, BR11, CR02, CR0J, CR11) 06.2005 → 12.2014	D4F 706 B	5
1.5 dCi (B/CB03) 06.2001 → 10.2003	K9K 702 D	18	1.2 16V (BR02, BR0J, BR11, CR02, CR0J, CR11) 06.2005 → 12.2014	D4F 740 BG	3
1.5 dCi (B/CB07) 06.2001 → 07.2009	K9K 700 D	18	1.2 16V (BR02, BR0J, BR11, CR02, CR0J, CR11) 06.2005 → 12.2014	D4F 764 B	5
1.5 dCi (B/CB07) 06.2001 → 07.2009	K9K 704 D	18	1.2 16V (BR0P, CR0P) 05.2007 → 12.2014	D4F 784 B	5
1.5 dCi (B/CB08) 06.2001 → 04.2005	K9K 702 D	18	1.2 16V (BR0R, BR1D, BR1L, CR0R) 06.2005 → 12.2012	D4F 740 BG	3
1.5 dCi (B/CB3M) 06.2005 → 12.2010	K9K 740 D	21	1.2 16V Hi-Flex (BR1U, CR1U) 07.2008 → 12.2012	D4F 740 BG	3
1.5 dCi (BB3N, CB3N) 02.2007 → 06.2009	K9K 718 D	20	1.2 Ethanol (CR1U, BR1U) 07.2008 → 12.2012	D4F 742 AB	6
1.6 06.1999 → 04.2003	K7M 746 B	32	1.4 16V 06.2005 → 12.2012	K4J 780 B	33
1.6 11.2004 → 02.2009	K4M 740 B	33	1.5 dCi 05.2005 → 07.2010	K9K 752 D	22
1.6 11.2004 → 02.2009	K4M 748 AB	38	1.5 dCi 06.2005 → 12.2012	K9K 752 D	22
1.6 (B/CB0D) 09.1998 → 05.2005	K7M 744 B	32	1.5 dCi 11.2007 → 12.2012	K9K 750 D	18
1.6 (B/CB0D) 09.1998 → 05.2005	K7M 745 B	32	1.5 dCi 08.2010 → 12.2014	K9K 766 D	22
1.6 (B/CB0D) 09.1998 → 05.2005	K7M 746 B	32	1.5 dCi 08.2010 → 12.2014	K9K 770 D	21
1.6 16V 03.1999 → 12.2008	K4M 708 B	33	1.5 dCi 08.2010 → 12.2014	K9K 770 D	21
			1.5 dCi (BR0H, CR0H, CR1S, BR1S) 06.2005 → 12.2014	K9K 764 D	19

		Pos			Pos
1.5 dCi (BR0H, CR0H, CR1S, BR1S)	K9K 774	D 21	1.2 TCe 120 (KHAU)	H5F 408	B 10
1.5 dCi (BR17, CR17)	K9K 766	D 22	1.2 TCe 120 (KHAU)	H5F 412	B 10
1.5 dCi (BR1C, CR1C)	K9K 772	D 21	1.2 TCe 120 (KHM0)	H5F 403	B 10
1.5 dCi (C/BR0G, C/BR1G)	K9K 714	D 18	1.5 dCi 110	K9K 646	D 21
1.5 dCi (C/BR0G, C/BR1G)	K9K 768	D 19	1.5 dCi 75	K9K 612	D 21
1.6 16V (BR05, BR0B, BR0Y, BR15, BR1J, BR1M, BR1Y, CR0B,...	K4M 800	B 36	1.5 dCi 75	K9K 628	D 21
1.6 16V (BR05, BR0B, BR0Y, BR15, BR1J, BR1M, BR1Y, CR0B,...	K4M 801	B 36	1.5 dCi 90 (KHN3, KHN4)	K9K 608	D 21
1.6 16V (BR09, BR0T, CR09, CR0T)	K4M 804	B 36	1.5 dCi 90 (KHN3, KHN4)	K9K 628	D 21
1.6 16V GT (BR10, CR10)	K4M 862	B 35	1.5 dCi 90 (KHN3, KHN4)	K9K 629	D 21
2.0 16V Sport	F4R 832	B 68	<b>CLIO V (B7_)</b>		
2.0 16V Sport (CR0N, CR1P)	F4R 830	B 65	1.5 Blue dCi 115 (B7AD)	K9K 872	D 25
2.0 16V Sport (CR0N, CR1P)	F4R 832	B 68	1.5 Blue dCi 85 (B7AG)	K9K 872	D 25
<b>CLIO III Grandtour (KR0/1_)</b>			<b>DUSTER (HM_)</b>		
1.2 16V	D4F 786	B 5	1.5 dCi 110 (HMAB)	K9K 656	D 25
1.2 16V (KR02, KR0J)	D4F 740	BG 3	1.5 dCi 110 (HMAB)	K9K 657	D 21
1.2 16V (KR0E)	D4F 764	B 5	1.5 dCi 110 4x4 (HMAB)	K9K 658	D 28
1.2 16V (KR0P)	D4F 784	B 5	1.5 dCi 90 (HMAA)	K9K 656	D 25
1.2 16V Hi-Flex (KR0S)	D4F 740	BG 3	<b>DUSTER (HS_)</b>		
1.2 16V Hi-Flex (KR1U)	D4F 742	AB 6	1.5 dCi	K9K 796	D 24
1.4 16V	K4J 780	B 33	1.5 dCi	K9K 896	D 27
1.5 dCi	K9K 752	D 22	1.5 dCi (HSAE, HSAD, HSAF, HSJ7, HSMC, HSMD)	K9K 856	D 25
1.5 dCi	K9K 770	D 21	1.5 dCi (HSAE, HSAD, HSAF, HSJ7, HSMC, HSMD)	K9K 898	D 25
1.5 dCi	K9K 770	D 21	1.5 dCi 4x4 (HSMC)	K9K 884	D 21
1.5 dCi	K9K 772	D 21	1.5 dCi 4x4 (HSMC)	K9K 896	D 27
1.5 dCi (KR0F)	K9K 766	D 22	1.5 dCi 4x4 (HSMD)	K9K 856	D 25
1.5 dCi (KR0G)	K9K 714	D 18	1.5 dCi 4x4 (HSMD)	K9K 858	D 25
1.5 dCi (KR0G)	K9K 768	D 19	1.6 16V	K4M 690	B 33
1.5 dCi (KR0H, KR1S)	K9K 764	D 19	1.6 16V	K4M 718	B 35
1.5 dCi (KR0H, KR1S)	K9K 774	D 21	1.6 16V (HSAT)	K4M 616	B 35
1.5 dCi (KR1C, KR1N)	K9K 772	D 21	1.6 16V (HSAT)	K4M 616	B 35
1.6 16V	K4M 804	B 36	1.6 16V 4x4	K4M 690	B 33
1.6 16V (KR0B)	K4M 800	B 36	1.6 16V 4x4 (HSA5, HSA9, HSMR, HSA8)	K4M 690	B 33
1.6 16V (KR0B)	K4M 801	B 36	1.6 Hi-Flex	K4M 690	B 33
1.6 16V (KR10)	K4M 862	B 35	1.6 Hi-Flex	K4M 694	AB 39
<b>CLIO IV (BH_)</b>			2.0	F4R 402	B 68
0.9 TCe 75 (BHNP)	H4B 408	B 11	2.0	F4R 404	AB 71
0.9 TCe 90	H4B 400	B 11	2.0	F4R 402	B 68
0.9 TCe 90	H4B 408	B 11	2.0	F4R 403	B 68
0.9 TCe 90 LPG	H4B 410	B 12	2.0	F4R 403	B 68
1.2 16V	D4F 728	B 5	2.0	F4R 405	AB 71
1.2 16V	D4F 740	BG 3	2.0 (HSAB)	F4R 410	B 68
1.2 16V (BHA1, BHAK, BHM6, BHM7)	D4F 740	BG 3	2.0 4x4	F4R 400	B 68
1.2 LPG (BHM6)	D4F 744	BG 3	2.0 4x4	F4R 402	B 68
1.2 LPG 16V	D4F 740	BG 3	2.0 4x4	F4R 402	B 68
1.2 TCe 120 (BHAU)	H5F 408	B 10	2.0 4x4	F4R 403	B 68
1.2 TCe 120 (BHAU)	H5F 412	B 10	2.0 4x4	F4R 400	B 68
1.2 TCe 120 (BHM0)	H5F 403	B 10	2.0 4x4	F4R 402	B 68
1.5 dCi (BHM6)	K9K 838	D 21	2.0 4x4	F4R 402	B 68
1.5 dCi (BHMW)	K9K 830	D 25	2.0 4x4	F4R 410	B 68
1.5 dCi 110	K9K 646	D 21	2.0 Flex	F4R 402	B 68
1.5 dCi 75	K9K 612	D 21	2.0 Flex	F4R 403	B 68
1.5 dCi 75	K9K 628	D 21	2.0 Flex	F4R 405	AB 71
1.5 dCi 90	K9K 608	D 21	2.0 Flex 4x4	F4R 400	B 68
1.5 dCi 90	K9K 628	D 21	2.0 Flex 4x4	F4R 402	B 68
<b>CLIO IV Grandtour (KH_)</b>			2.0 Flex 4x4	F4R 408	B 68
0.9 TCe 75 (KHNP)	H4B 408	B 11	2.0 Flex 4x4	F4R 402	B 68
0.9 TCe 90	H4B 400	B 11	2.0 Flex 4x4	F4R 402	B 68
0.9 TCe 90	H4B 408	B 11	2.0 Flex 4x4	F4R 408	B 68
1.2 16V	D4F 740	BG 3	2.0 Flex 4x4	F4R 402	B 68
			2.0 Flex 4x4	F4R 403	B 68
			2.0 Hi-Flex	F4R 402	B 68
			2.0 Hi-Flex	F4R 403	B 68
			2.0 Hi-Flex	F4R 404	AB 71
			2.0 Hi-Flex	F4R 405	AB 71
			2.0 Hi-Flex	F4R 416	AB 71
			2.0 Hi-Flex 4x4	F4R 400	B 68

R

		Pos			Pos				
2.0 Hi-Flex 4x4	01.2011 → 12.2015	F4R 402	B	68	2.0 Turbo (JK0A, JK0B, 11.2002 → JK0N)	F4R 795	B	65	
2.0 Hi-Flex 4x4	01.2011 → 12.2015	F4R 408	B	68	2.0 Turbo (JK0A, JK0B, 11.2002 → JK0N)	F4R 796	B	65	
<b>ESPACE I (J11_)</b>									
2.0 (J/S112)	07.1984 → 12.1987	J6R 234	B	95	2.0 Turbo (JK0A, JK0B, 11.2002 → JK0N)	F4R 797	B	65	
2.0 (J/S112)	01.1988 → 12.1990	J6R 236	B	95	2.0 dCi (JK01, JK02, 01.2006 → JK1J, JK1K, JK1H)	M9R 740	D	73	
2.0 (J/S112)	01.1988 → 12.1990	J6R 734	B	95	2.0 dCi (JK01, JK02, 01.2006 → JK1J, JK1K, JK1H)	M9R 750	D	73	
2.0 i (J116)	01.1989 → 12.1990	J7R 760	B	95	2.0 dCi (JK01, JK02, 01.2006 → JK1J, JK1K, JK1H)	M9R 814	D	73	
2.0 i Quadra (J116)	03.1988 → 12.1992	J7R 760	B	95	2.0 dCi (JK01, JK02, 01.2006 → JK1J, JK1K, JK1H)	M9R 815	D	73	
2.1 TD (J/S115)	10.1984 → 12.1990	J8S 240	D	89	2.0 dCi (JK01, JK02, 01.2006 → JK1J, JK1K, JK1H)	M9R 858	D	75	
2.1 TD (J/S115)	10.1984 → 12.1990	J8S 776	D	89	2.0 dCi (JK02, JK03)	M9R 740	D	73	
2.1 TD (J/S115)	01.1989 → 12.1990	J8S 774	D	89	2.0 dCi (JK02, JK03)	M9R 750	D	73	
2.2 (J117)	07.1986 → 12.1990	J7T 770	B	95	2.0 dCi (JK02, JK03)	M9R 760	D	73	
2.2 Quadra	06.1987 → 12.1987	J7T 770	B	95	2.0 dCi (JK02, JK03)	M9R 761	D	73	
2.2 Quadra (J117)	01.1988 → 12.1990	J7T 770	B	95	2.0 dCi (JK02, JK03)	M9R 762	D	73	
<b>ESPACE II (J/S63_)</b>									
2.0 (J636)	01.1991 → 10.1996	J7R 768	B	95	2.0 dCi (JK02, JK03)	M9R 763	D	73	
2.1 RTDT Quadra	01.1991 → 05.1992	J8S 772	D	89	2.0 dCi (JK03, JK04, 01.2006 → JK1C, JK1G, JK1J, JK1K)	M9R 760	D	73	
2.1 TD (J633, J634, J/S635, J/S63D)	01.1991 → 10.1996	J8S 610	D	89	2.0 dCi (JK03, JK04, 01.2006 → JK1C, JK1G, JK1J, JK1K)	M9R 761	D	73	
2.1 TD (J633, J634, J/S635, J/S63D)	01.1991 → 10.1996	J8S 772	D	89	2.0 dCi (JK03, JK04, 01.2006 → JK1C, JK1G, JK1J, JK1K)	M9R 762	D	73	
2.1 TD (J633, J634, J/S635, J/S63D)	01.1991 → 10.1996	J8S 776	D	89	2.0 dCi (JK03, JK04, 01.2006 → JK1C, JK1G, JK1J, JK1K)	M9R 763	D	73	
2.1 TD (J633, J634, J/S635, J/S63D)	01.1991 → 10.1996	J8S 778	D	89	2.0 dCi (JK03, JK04, 01.2006 → JK1C, JK1G, JK1J, JK1K)	M9R 760	D	73	
2.1 TD (J63E)	11.1994 → 10.1996	J8S 612	D	89	2.0 dCi (JK03, JK04, 01.2006 → JK1C, JK1G, JK1J, JK1K)	M9R 761	D	73	
2.2 (J/S637, J63G)	01.1991 → 10.1996	J7T 772	B	95	2.0 dCi (JK03, JK04, 01.2006 → JK1C, JK1G, JK1J, JK1K)	M9R 762	D	73	
2.2 (J/S637, J63G)	01.1991 → 10.1996	J7T 773	B	95	2.0 dCi (JK03, JK04, 01.2006 → JK1C, JK1G, JK1J, JK1K)	M9R 763	D	73	
2.2 (J/S637, J63G)	01.1991 → 10.1996	J7T 776	B	95	2.0 dCi (JK03, JK04, 01.2006 → JK1C, JK1G, JK1J, JK1K)	M9R 760	D	73	
2.2 4x4 (J/S637, J63G)	03.1991 → 12.1996	J7T 772	B	95	2.0 dCi (JK03, JK04, 01.2006 → JK1C, JK1G, JK1J, JK1K)	M9R 761	D	73	
2.2 4x4 (J/S637, J63G)	03.1991 → 12.1996	J7T 773	B	95	2.0 dCi (JK03, JK04, 01.2006 → JK1C, JK1G, JK1J, JK1K)	M9R 762	D	73	
2.8 V6 (J638, J63J)	01.1991 → 10.1996	Z7W 712	B	97	2.0 dCi (JK03, JK04, 01.2006 → JK1C, JK1G, JK1J, JK1K)	M9R 763	D	73	
2.8 V6 (J638, J63J)	01.1991 → 10.1996	Z7W 713	B	97	2.0 dCi (JK03, JK04, 01.2006 → JK1C, JK1G, JK1J, JK1K)	M9R 812	D	74	
2.8 V6 (J638, J63J)	01.1991 → 10.1996	Z7W 717	B	97	2.0 dCi (JK03, JK04, 01.2006 → JK1C, JK1G, JK1J, JK1K)	M9R 815	D	73	
<b>ESPACE III (JE0_)</b>									
1.9 dTi (JE0M)	02.1999 → 10.2002	F9Q 722	D	48	2.0 dCi (JK03, JK04, 01.2006 → JK1C, JK1G, JK1J, JK1K)	M9R 859	D	75	
2.0	09.2001 → 10.2002	F4R 700	B	65	2.2 dCi (JK07)	G9T 645	D	94	
2.0	09.2001 → 10.2002	F4R 701	B	65	2.2 dCi (JK0H)	G9T 742	D	94	
2.0 (JE0A)	11.1996 → 10.2000	F3R 728	B	64	2.2 dCi (JK0H)	G9T 743	D	94	
2.0 (JE0A)	11.1996 → 10.2000	F3R 729	B	64	<b>ESPACE V (JR_)</b>				
2.0 (JE0A)	11.1996 → 10.2000	F3R 742	B	61	1.6 dCi 130	06.2015 →	R9M 409	D	53
2.0 (JE0A)	11.1996 → 10.2000	F3R 768	B	63	1.6 dCi 160	06.2015 →	R9M 452	D	53
2.0 (JE0A)	11.1996 → 10.2000	F3R 769	B	61	<b>EXPRESS</b>				
2.0 16V (JE0N, JE0L, JE02)	10.1998 → 10.2002	F4R 700	B	65	1.0	03.1986 → 08.1991	C1C 706	B	2
2.0 16V (JE0N, JE0L, JE02)	10.1998 → 10.2002	F4R 701	B	65	1.0	03.1986 → 08.1991	C1C 754	B	2
2.2 12V TD (JE0E, JE0H, JE0P)	11.1996 → 10.2000	G8T 714	D	93	1.1	03.1986 → 07.1990	C1E 688	B	7
2.2 12V TD (JE0E, JE0H, JE0P)	11.1996 → 10.2000	G8T 716	D	92	1.1	03.1986 → 07.1990	C1E 750	B	7
2.2 12V TD (JE0E, JE0H, JE0P)	11.1996 → 10.2000	G8T 760	D	91	1.1	03.1986 → 07.1990	C1E 752	B	7
2.2 D	11.1997 → 01.2000	G8T 716	D	92	1.1	03.1986 → 08.1991	C1E 754	B	7
2.2 dCi (JE0K)	10.2000 → 10.2002	G9T 642	D	94	1.1	06.1987 → 08.1991	C1E 756	B	7
2.2 dCi (JE0K)	10.2000 → 10.2002	G9T 710	D	94	1.1	09.1991 → 10.1997	C1E 764	B	7
2.2 dCi (JE0S)	07.2000 → 10.2002	G9T 710	D	94	1.1	07.1993 → 09.1994	C1E 762	B	7
<b>ESPACE IV (JK0/1_)</b>									
1.9 dCi (JK0U)	04.2003 → 02.2005	F9Q 820	D	49	1.2i	09.1991 → 10.1997	C3G 700	B	14
1.9 dCi (JK0U, JK0G)	11.2002 →	F9Q 680	D	49	1.2i	07.1993 → 06.1997	C3G 710	B	14
1.9 dCi (JK0U, JK0G)	11.2002 →	F9Q 820	D	49	1.2i	12.1996 → 06.1997	C3G 712	B	14
1.9 dCi (JK0U, JK0G)	11.2002 →	F9Q 826	D	49	1.4	03.1986 → 05.1987	C3J 700	B	17
2.0 (JK09)	11.2002 → 01.2015	F4R 792	B	65	1.4	03.1986 → 06.1989	C1J 768	B	17
2.0 (JK0A, JK1D, JK0N)	04.2005 →	F4R 796	B	65	1.4	03.1986 → 08.1991	C1J 780	B	17
2.0 (JK0A, JK1D, JK0N)	04.2005 →	F4R 797	B	65	1.4	03.1986 → 09.1997	C1J 715	B	17
2.0 (JK0A, JK1D, JK0N)	04.2005 →	F4R 896	B	68	1.4	06.1987 → 08.1991	C3J 702	B	17
2.0 (JK0A, JK1D, JK0N)	04.2005 →	F4R 897	B	68	1.4	06.1987 → 09.1997	C2J 782	B	17
2.0 (JK0K)	11.2002 → 12.2015	F4R 790	B	65	1.4	06.1987 → 09.1997	C2J 784	B	17
2.0 Turbo (JK0A, JK0B, JK0N)	11.2002 →	F4R 794	B	65	1.4i	03.1986 → 09.1997	E6J 712	B	16
					1.4i	03.1986 → 09.1997	E6J 734	B	16

R



			Pos				Pos		
1.4i	03.1986 → 09.1997	E6J 738	B	16	1.5 dCi (JM02, JM13)	04.2004 → 11.2008	K9K 728	D	18
1.4i	06.1987 → 08.1991	C3J 760	B	15	1.5 dCi (JM1E)	05.2005 → 01.2009	K9K 732	D	19
1.4i	09.1991 → 03.1997	C3J 762	B	15	1.6	04.2004 → 08.2006	K4M 761	B	34
1.4i	09.1991 → 10.1997	E7J 720	B	16	1.6	04.2004 → 08.2006	K4M 782	B	34
1.4i	09.1991 → 10.1997	E7J 724	B	16	1.6	06.2006 → 11.2008	K4M 788	B	34
1.4i	09.1991 → 10.1997	E7J 726	B	16	1.6	06.2006 → 11.2008	K4M 812	B	36
1.4i	09.1991 → 10.1997	E7J 754	B	16	1.6 Flex	06.2006 → 06.2009	K4M 766	B	35
1.4i	03.1994 → 10.1997	E7J 728	B	16	1.9 dCi	05.2005 → 01.2009	F9Q 803	D	49
1.4i	03.1994 → 10.1997	E7J 773	B	16	1.9 dCi	05.2005 → 01.2009	F9Q 804	D	51
1.4i	03.1996 → 09.1997	E7J 770	B	16	1.9 dCi	05.2005 → 01.2009	F9Q 812	D	49
1.4i	03.1996 → 09.1997	E7J 771	B	16	1.9 dCi (JM0G, JM12, JM1G, JM2C)	04.2004 → 05.2006	F9Q 812	D	49
1.6 D	03.1986 → 03.1997	F8M 720	D	30	1.9 dCi (JM14)	04.2004 → 02.2008	F9Q 816	D	49
1.6 D	10.1987 → 03.1997	F8M 730	D	30	1.9 dCi (JM14)	04.2004 → 02.2008	F9Q 818	D	49
1.6 D	09.1991 → 03.1997	F8M 736	D	30	1.9 dCi (JM14)	04.2004 → 02.2008	F9Q EE 804	D	51
1.9 D	09.1991 → 03.1997	F8Q 776	D	42	1.9 dCi (JM14)	04.2004 → 02.2008	F9Q J 803	D	49
1.9 D	09.1991 → 10.1997	F8Q 722	D	42	1.9 dCi (JM14)	04.2004 → 02.2008	F9Q J 803	D	49
1.9 D	09.1991 → 10.1997	F8Q 724	D	42	1.9 dCi (JM15)	05.2005 → 11.2008	F9Q E 804	D	51
1.9 D	09.1991 → 10.1997	F8Q 730	D	42	2.0	04.2004 → 06.2009	F4R 770	B	65
1.9 D	09.1991 → 10.1997	F8Q 732	D	42	2.0	04.2004 → 06.2009	F4R 771	B	65
1.9 D	09.1991 → 10.1997	F8Q 774	D	42	2.0	04.2004 → 06.2009	F4R 776	B	65
<b>EXPRESS Pickup</b>					2.0 dCi (JM1K)	09.2005 → 11.2008	M9R 700	D	73
1.2	07.1995 → 10.1999	C3G 710	B	14	2.0 dCi (JM1K)	09.2005 → 11.2008	M9R 721	D	73
1.9 D	07.1995 → 10.1997	F8Q 640	D	40	2.0 dCi (JM1K)	09.2005 → 11.2008	M9R 722	D	73
1.9 D	07.1995 → 10.1999	F8Q 724	D	42	<b>GRAND SCÉNIC III (JZ0/1_)</b>				
1.9 D	07.1995 → 10.1999	F8Q 776	D	42	1.2 TCe	04.2012 →	H5F 400	B	10
<b>FLUENCE (L3_)</b>					1.2 TCe	07.2014 →	H5F 408	B	10
1.5 dCi	07.2014 →	K9K 826	D	21	1.2 TCe (JZ16)	01.2013 →	H5F 404	B	10
1.5 dCi (L30A)	02.2010 →	K9K 830	D	25	1.5 dCi	02.2009 →	K9K 832	D	21
1.5 dCi (L30B)	02.2010 →	K9K 832	D	21	1.5 dCi	04.2009 →	K9K 636	D	21
1.5 dCi (L30D, L30L, L306, L33F, L33L, L33M, L33V, L33W)	02.2010 →	K9K 656	D	25	1.5 dCi	04.2009 →	K9K 830	D	25
1.5 dCi (L30D, L30L, L306, L33F, L33L, L33M, L33V, L33W)	02.2010 →	K9K 657	D	21	1.5 dCi	04.2009 →	K9K 836	D	21
1.5 dCi (L30D, L30L, L306, L33F, L33L, L33M, L33V, L33W)	02.2010 →	K9K 836	D	21	1.5 dCi	04.2009 →	K9K 837	D	21
1.5 dCi (L30D, L30L, L306, L33F, L33L, L33M, L33V, L33W)	02.2010 →	K9K 837	D	21	1.5 dCi	11.2010 →	K9K 846	D	25
1.5 dCi (L30S)	02.2010 →	K9K 834	D	21	1.6 16V (JZ0U)	02.2009 →	K4M 858	B	35
1.6 16V	02.2010 →	K4M 838	B	35	1.6 16V Bifuel	02.2009 →	K4M 866	B	35
1.6 16V (L301, L30F, L30P, L30R)	02.2010 →	K4M 838	B	35	1.6 16V Bifuel	04.2012 →	K4M 866	B	35
1.6 16V (L301, L30F, L30P, L30R)	02.2010 →	K4M 839	B	35	1.6 E85	02.2009 →	K4M 866	B	35
1.6 16V (L304, L305, L30H)	02.2010 →	K4M 838	B	35	1.6 dCi (JZ00, JZ12)	04.2011 →	R9M 402	D	52
1.6 Flex	01.2012 → 11.2014	K4M 838	B	35	1.6 dCi (JZ00, JZ12)	04.2011 →	R9M 404	D	52
1.6 LPG 16V	01.2012 →	K4M 839	B	35	1.6 dCi (JZ00, JZ12)	04.2011 →	R9M 414	D	53
1.6 dCi	07.2014 →	R9M 402	D	52	2.0 dCi (JZ0L)	04.2009 →	M9R 610	D	73
2.0	02.2011 → 11.2014	F4R 872	B	68	2.0 dCi (JZ0Y)	02.2009 →	M9R 615	D	73
2.0	01.2013 →	F4R 872	B	68	<b>GRAND SCÉNIC IV (R9_)</b>				
<b>FUEGO (136_)</b>					1.2 TCe 115	09.2016 →	H5F 408	B	10
1.4 TL/GTL	02.1980 → 10.1985	847 720	B	17	1.2 TCe 130	09.2016 →	H5F 408	B	10
2.0 TX/GTX	02.1981 → 11.1986	J6R 714	B	95	1.5 dCi 110	09.2016 →	K9K 646	D	21
2.0 TX/GTX (1363)	10.1980 → 10.1985	829 710	B	95	1.5 dCi 110	09.2016 →	K9K 647	D	21
2.0 TX/GTX (1363)	10.1980 → 10.1985	J6R 710	B	95	1.5 dCi 110 Hybrid	04.2017 →	K9K 500	D	21
2.0 TX/GTX (1363)	10.1980 → 10.1985	J6R 712	B	95	Assist (R9AE)				
2.0 TX/GTX (1363)	10.1980 → 10.1985	J6R 713	B	95	1.6 dCi 130	09.2016 →	R9M 409	D	53
2.0 TX/GTX (1363)	10.1980 → 10.1985	J6R 715	B	95	1.6 dCi 160	09.2016 →	R9M 452	D	53
2.0 TX/GTX (1363)	10.1980 → 10.1985	J6R 726	B	95	<b>KADJAR (HA_ , HL_)</b>				
2.1 TD	08.1982 → 10.1985	J8S 712	D	89	1.2 TCe 130	06.2015 →	H5F 408	B	10
2.2	10.1983 → 10.1985	J7T 718	B	95	1.5 BLUE dCi 115	08.2018 →	K9K 872	D	25
2.2	11.1984 → 06.1988	J7T 718	B	95	1.5 BLUE dCi 115	08.2018 →	K9K 873	D	21
2.2	05.1985 → 11.1992	J7T 718	B	95	1.5 dCi 110 (HLA3)	06.2015 →	K9K 646	D	21
2.2	05.1985 → 11.1992	J7T 718	B	95	1.5 dCi 110 (HLA3)	06.2015 →	K9K 647	D	21
<b>GRAND SCÉNIC II (JM0/1_)</b>					1.6 dCi 130	06.2015 →	R9M 414	D	53
1.5 dCi	06.2006 → 11.2008	K9K 734	D	19	1.6 dCi 130 4x4	06.2015 →	R9M 414	D	53
					<b>KANGOO (KC0/1_)</b>				
					1.0	01.2002 → 01.2007	D4D 700	B	5
					1.0	01.2002 → 01.2007	D4D 720	B	5
					1.2 (KC0A, KC0K, KC0F, KC01)	08.1997 →	D7F 720	B	4
					1.2 (KC0A, KC0K, KC0F, KC01)	08.1997 →	D7F 722	B	4
					1.2 (KC0A, KC0K, KC0F, KC01)	08.1997 →	D7F 726	B	4
					1.2 (KC0A, KC0K, KC0F, KC01)	08.1997 →	D7F 744	B	4

		Pos			Pos	
1.2 (KC0A, KC0K, KC0F, 08.1997 → KC01)	D7F 746	B	4	1.5 dCi 110 (KW06, KW12)	D	21
1.2 (KC0A, KC0K, KC0F, 03.1998 → KC01)	D7F 710	B	4	1.5 dCi 110 (KW06, KW12)	D	21
1.2 16V (KC05, KC06, KC03, KC0T, KC0W, KC1D)	D4F 712	B	5	1.5 dCi 110 (KW06, KW12)	D	21
1.2 16V (KC05, KC06, KC03, KC0T, KC0W, KC1D)	D4F 714	B	5	1.5 dCi 110 (KW0C, KW0H)	D	19
1.2 16V (KC05, KC06, KC03, KC0T, KC0W, KC1D)	D4F 716	B	5	1.5 dCi 110 (KW0C, KW0H)	D	21
1.2 16V (KC05, KC06, KC03, KC0T, KC0W, KC1D)	D4F 716	B	5	1.5 dCi 115 (KW17)	D	25
1.2 16V (KC05, KC06, KC03, KC0T, KC0W, KC1D)	D4F 730	B	5	1.5 dCi 70 (KW0V, KW0A)	D	19
1.4 (KC0C, KC0H, KC0B, 08.1997 → KC0M)	E7J 634	B	16	1.5 dCi 70 (KW0V, KW0A)	D	19
1.4 (KC0C, KC0H, KC0B, 08.1997 → KC0M)	E7J 635	B	16	1.5 dCi 75 (KW07, KW10, KW04)	D	21
1.4 (KC0C, KC0H, KC0B, 08.1997 → KC0M)	K7J 700	B	16	1.5 dCi 75 (KW07, KW10, KW04)	D	21
1.4 (KC0C, KC0H, KC0B, 08.1997 → KC0M)	K7J 701	B	16	1.5 dCi 75 (KW07, KW10, KW04)	D	21
1.4 (KC0C, KC0H, KC0B, 08.1997 → KC0M)	K7J 701	B	16	1.5 dCi 80 (KW15)	D	25
1.4 (KC0C, KC0H, KC0B, 03.1998 → KC0M)	E7J 780	B	16	1.5 dCi 80 (KW15)	D	19
1.5 dCi	K9K 704	D	18	1.5 dCi 85 (KW0K, KW0L, KW0B)	D	21
1.5 dCi	K9K 700	D	18	1.5 dCi 85 (KW0K, KW0L, KW0B)	D	21
1.5 dCi	K9K 702	D	18	1.5 dCi 90 (KW05, KW08, KW0G, KW11)	D	21
1.5 dCi	K9K 714	D	18	1.5 dCi 90 (KW05, KW08, KW0G, KW11)	D	21
1.5 dCi	K9K 718	D	20	1.5 dCi 90 (KW05, KW08, KW0G, KW11)	D	21
1.5 dCi (KC07)	K9K 700	D	18	1.5 dCi 90 (KW05, KW08, KW0G, KW11)	D	21
1.5 dCi (KC07)	K9K 704	D	18	1.5 dCi 90 (KW18)	D	21
1.5 dCi (KC08, KC09)	K9K 702	D	18	1.5 dCi 95 (KW16)	D	25
1.5 dCi (KC08, KC09)	K9K 710	D	18	1.6 (KW00, KW0Y, KW0E, KW0N, KW0P)	B	32
1.6	K7M 746	B	32	1.6 16V (KW03, KW09, KW0D, KW0U, KW0W, KW13)	B	33
1.6	K4M 730	B	33	1.6 16V (KW03, KW09, KW0D, KW0U, KW0W, KW13)	B	35
1.6	K4M 706	B	33	1.6 16V (KW03, KW09, KW0D, KW0U, KW0W, KW13)	B	35
1.6 16V	K4M 706	B	33	1.6 16V (KW03, KW09, KW0D, KW0U, KW0W, KW13)	B	35
1.6 16V	K4M 730	B	33	1.6 16V (KW03, KW09, KW0D, KW0U, KW0W, KW13)	B	35
1.6 16V	K4M 750	B	33	1.6 16V (KW03, KW09, KW0D, KW0U, KW0W, KW13)	B	35
1.6 16V	K4M 752	B	33	1.6 16V (KW03, KW09, KW0D, KW0U, KW0W, KW13)	B	35
1.6 16V	K4M 753	B	33	1.6 16V (KW03, KW09, KW0D, KW0U, KW0W, KW13)	B	35
1.6 16V 4x4 (KC0P, KC0S, KC0L)	K4M 750	B	33	1.6 16V (KW03, KW09, KW0D, KW0U, KW0W, KW13)	B	35
1.6 16V 4x4 (KC0P, KC0S, KC0L)	K4M 752	B	33	1.6 16V FLEX (KW01)	B	35
1.6 16V 4x4 (KC0P, KC0S, KC0L)	K4M 753	B	33	1.6 16V LPG (KW0U)	B	35
1.6 16V bivalent	K4M 850	AB	39	1.6 SCe (FW17)	B	33
1.6 Flex	K4M 730	B	33	<b>KANGOO BE BOP (KW0/1_)</b>		
1.9 RXED	F8Q 632	D	45	1.5 dCi	D	19
1.9 dCi 4x4	F9Q 790	D	50	1.5 dCi	D	18
1.9 dCi 4x4 (KC0V)	F9Q 782	D	50	1.5 dCi (KW0F)	D	21
1.9 dCi 4x4 (KC0V)	F9Q 790	D	50	1.5 dCi (KW0G)	D	21
1.9 dTi (KC0U)	F9Q 780	D	50	1.5 dCi 75	D	19
D 55 1.9 (KC0D)	F8Q 662	D	47	1.6 (KW0D)	B	33
D 65 1.9 (KC0E, KC02, KC0J, KC0N)	F8Q 632	D	45	1.6 16V	B	33
D 65 1.9 (KC0E, KC02, KC0J, KC0N)	F8Q 630	D	47	<b>KAPTUR (H5_)</b>		
<b>KANGOO / GRAND KANGOO (KW0/1_)</b>			<b>KOLEOS I (HY_)</b>			
1.2 TCe 115 (KW02, KW14)	H5F 400	B	10	2.0 4WD	B	68
1.2 TCe 115 (KW02, KW14)	H5F 408	B	10	<b>KOLEOS I (HY_)</b>		
1.2 TCe 115 (KW02, KW14)	H5F 412	B	10	2.0 dCi	D	79
1.5 dCi	K9K 804	D	19	2.0 dCi (HY0K)	D	79
1.5 dCi 105 (KW0F)	K9K 806	D	21	2.0 dCi (HY0K)	D	79
				2.0 dCi (HY0K)	D	79
				2.0 dCi (HY0K)	D	79
				2.0 dCi (HY0K)	D	79
				2.0 dCi (HY0K)	D	79
				2.0 dCi (HY0K)	D	79
				2.0 dCi (HY0K)	D	79
				2.0 dCi 4x4	D	73
				2.0 dCi 4x4 (HY0B)	D	73
				2.0 dCi 4x4 (HY0K)	D	73
				2.0 dCi 4x4 (HY0K)	D	73
				2.0 dCi 4x4 (HY0K)	D	73
				2.0 dCi 4x4 (HY0K)	D	80
				2.0 dCi 4x4 (HY0K)	D	80



			Pos				Pos		
2.0 dCi 4x4 (HY0K)	09.2008 →	M9R 836	D	80	1.8	06.1995 → 06.1998	F3P 678	B	61
2.0 dCi 4x4 (HY0K)	09.2008 →	M9R 838	D	80	1.8	06.1995 → 02.2001	F3P 674	B	61
2.0 dCi 4x4 (HY0K)	09.2008 →	M9R 850	D	75	1.8 (B56A/B)	11.1993 → 03.2001	F3P 720	B	61
2.0 dCi 4x4 (HY0K)	09.2008 →	M9R 855	D	79	1.8 (B56A/B)	11.1993 → 03.2001	F3P 724	B	61
2.0 dCi 4x4 (HY0K)	09.2008 →	M9R 856	D	79	1.8 (B56S/T/0)	08.1995 → 03.2001	F3P 670	B	60
2.0 dCi 4x4 (HY0K)	09.2008 →	M9R 862	D	79	1.8 (B56S/T/0)	08.1995 → 03.2001	F3P 678	B	61
2.0 dCi 4x4 (HY0K)	09.2008 →	M9R 865	D	79	1.8 (B56Z)	08.1995 → 03.2001	F3P 720	B	61
2.0 dCi 4x4 (HY0K)	09.2008 →	M9R 866	D	79	1.8 (B56Z)	08.1995 → 03.2001	F3P 724	B	61
<b>KOLEOS II (HC )</b>					1.8 16V (B563, B564)	04.1998 → 03.2001	F4P 760	B	65
1.6 dCi 130	08.2016 →	R9M 409	D	53	1.8 16V (B563, B564)	04.1998 → 03.2001	F4P 770	B	65
1.6 dCi 130	08.2016 →	R9M 414	D	53	1.9 dCi (B56W)	09.1999 → 03.2001	F9Q 718	D	50
<b>LAGUNA Coupe (DT0/1)</b>					1.9 dTi	06.1998 → 08.2002	F9Q 716	D	46
1.5 dCi	03.2012 → 12.2015	K9K 846	D	25	1.9 dTi (B56J)	10.1997 → 03.2001	F9Q 710	D	46
2.0 16V Turbo	09.2008 → 12.2015	F4R 811	B	65	1.9 dTi (B56J)	10.1997 → 03.2001	F9Q 716	D	46
2.0 16V Turbo	09.2008 → 12.2015	F4Rt 811	B	65	1.9 dTi (B56J)	10.1997 → 03.2001	F9Q 717	D	46
2.0 GT	09.2008 → 12.2015	F4R 800	B	65	2.0	06.1995 → 02.2001	F3R 722	B	61
2.0 dCi (DT01, DT08, DT09, DT0K, DT12, DT1C, DT1D, DT1M,....	09.2008 → 12.2015	M9R 744	D	73	2.0	06.1995 → 02.2001	F3R 768	B	63
2.0 dCi (DT01, DT08, DT09, DT0K, DT12, DT1C, DT1D, DT1M,....	09.2008 → 12.2015	M9R 748	D	73	2.0	06.1995 → 02.2001	N7Q 700	B	72
2.0 dCi (DT01, DT08, DT09, DT0K, DT12, DT1C, DT1D, DT1M,....	09.2008 → 12.2015	M9R 754	D	78	2.0	06.1995 → 02.2001	N7Q 704	B	72
2.0 dCi (DT01, DT08, DT09, DT0K, DT12, DT1C, DT1D, DT1M,....	09.2008 → 12.2015	M9R 802	D	73	2.0	09.1995 → 02.2001	F3R 768	B	63
2.0 dCi (DT01, DT08, DT09, DT0K, DT12, DT1C, DT1D, DT1M,....	09.2008 → 12.2015	M9R 805	D	73	2.0	03.1999 → 03.2001	F3R 611	B	61
2.0 dCi (DT01, DT08, DT09, DT0K, DT12, DT1C, DT1D, DT1M,....	09.2008 → 12.2015	M9R 808	D	78	2.0 (556A)	09.1999 → 02.2001	F4R 780	B	65
2.0 dCi (DT01, DT08, DT09, DT0K, DT12, DT1C, DT1D, DT1M,....	09.2008 → 12.2015	M9R 814	D	73	2.0 (B56C/H/N)	12.1993 → 03.2001	F3R 722	B	61
2.0 dCi (DT01, DT08, DT09, DT0K, DT12, DT1C, DT1D, DT1M,....	09.2008 → 12.2015	M9R 845	D	79	2.0 (B56C/H/N)	12.1993 → 03.2001	F3R 723	B	61
2.0 dCi (DT01, DT08, DT09, DT0K, DT12, DT1C, DT1D, DT1M,....	09.2008 → 12.2015	M9R 854	D	75	2.0 16V (556A/B)	09.1999 → 03.2001	F4R 780	B	65
2.0 dCi (DT01, DT08, DT09, DT0K, DT12, DT1C, DT1D, DT1M,....	09.2008 → 12.2015	M9R 858	D	75	2.0 16V (B56D/M)	08.1995 → 03.2001	N7Q 700	B	72
2.0 dCi (DT0M, DT0N, DT0S, DT19, DT1F)	09.2008 → 12.2015	M9R 800	D	73	2.0 16V (B56D/M)	08.1995 → 03.2001	N7Q 704	B	72
2.0 dCi (DT0M, DT0N, DT0S, DT19, DT1F)	09.2008 → 12.2015	M9R 806	D	74	2.2 D (B56F/2)	11.1993 → 11.1995	G8T 706	D	90
2.0 dCi (DT0M, DT0N, DT0S, DT19, DT1F)	09.2008 → 12.2015	M9R 809	D	73	2.2 D (B56F/2)	11.1993 → 11.1995	G8T 790	D	90
2.0 dCi (DT0M, DT0N, DT0S, DT19, DT1F)	09.2008 → 12.2015	M9R 815	D	73	2.2 D (B56F/2)	11.1995 → 03.2001	G8T 752	D	90
2.0 dCi (DT0M, DT0N, DT0S, DT19, DT1F)	09.2008 → 12.2015	M9R 849	D	79	2.2 D (B56F/2)	11.1995 → 03.2001	G8T 794	D	90
2.0 dCi (DT0M, DT0N, DT0S, DT19, DT1F)	09.2008 → 12.2015	M9R 854	D	75	2.2 dT (B569)	03.1996 → 03.2001	G8T 760	D	91
2.0 dCi (DT0M, DT0N, DT0S, DT19, DT1F)	09.2008 → 12.2015	M9R 857	D	75	<b>LAGUNA I Grandtour (K56 )</b>				
2.0 dCi GT (DT11, DT1E, DT1N)	09.2008 → 12.2015	M9R 816	D	73	1.6 16V (K568)	11.1997 → 03.2001	K4M 720	B	33
2.0 dCi GT (DT11, DT1E, DT1N)	09.2008 → 12.2015	M9R 820	D	73	1.6 16V (K568)	11.1997 → 03.2001	K4M 724	B	34
2.0 dCi GT (DT11, DT1E, DT1N)	09.2008 → 12.2015	M9R 828	D	75	1.8 (K56S/T/0)	09.1995 → 03.2001	F3P 670	B	60
<b>LAGUNA GRANDTOUR</b>					1.8 (K56S/T/0)	09.1995 → 03.2001	F3P 678	B	61
1.9 dCi	09.1999 → 02.2001	F9Q 718	D	50	1.8 (K56Z)	09.1995 → 03.2001	F3P 678	B	61
<b>LAGUNA I (B56 , 556 )</b>					1.8 (K56Z)	09.1995 → 03.2001	F3P 720	B	61
1.6 16V (B568, B561)	11.1997 → 03.2001	K4M 720	B	33	1.8 (K56Z)	09.1995 → 03.2001	F3P 724	B	61
1.6 16V (B568, B561)	11.1997 → 03.2001	K4M 724	B	34	1.8 16V (K563, K564)	04.1998 → 03.2001	F4P 760	B	65
1.8	06.1995 → 06.1998	F3P 676	B	60	1.9 dCi (K56W)	09.1999 → 03.2001	F9Q 718	D	50
					1.9 dTi (K56J)	10.1997 → 03.2001	F9Q 710	D	46
					1.9 dTi (K56J)	10.1997 → 03.2001	F9Q 716	D	46
					1.9 dTi (K56J)	10.1997 → 03.2001	F9Q 717	D	46
					2.0	10.1998 → 01.2001	F3R 728	B	64
					2.0	10.1998 → 01.2001	F3R 768	B	63
					2.0 (K56C/H)	09.1995 → 03.2001	F3R 722	B	61
					2.0 (K56C/H)	09.1995 → 03.2001	F3R 723	B	61
					2.0 16V (A56A/B)	09.1999 → 03.2001	F4R 780	B	65
					2.0 16V (K56D/M)	09.1995 → 03.2001	N7Q 700	B	72
					2.0 16V (K56D/M)	09.1995 → 03.2001	N7Q 704	B	72
					2.2 D (K56F/2, S56F)	09.1995 → 11.1995	G8T 706	D	90
					2.2 D (K56F/2, S56F)	09.1995 → 11.1995	G8T 790	D	90
					2.2 D (K56F/2, S56F)	11.1995 → 03.2001	G8T 752	D	90
					2.2 D (K56F/2, S56F)	11.1995 → 03.2001	G8T 794	D	90
					2.2 dT (K569)	03.1996 → 03.2001	G8T 760	D	91
					<b>LAGUNA II (BG0/1 )</b>				
					1.6	03.2001 → 05.2005	K4M 710	B	33
					1.6 16V (BG0A, BG0L)	03.2001 → 05.2005	K4M 710	B	33
					1.6 16V (BG0A, BG0L)	03.2001 → 05.2005	K4M 714	B	33
					1.6 16V (BG1G, BG1H)	02.2005 → 08.2007	K4M 716	B	34
					1.6 LPG	03.2001 → 05.2005	K4M 714	B	33
					1.6 LPG	03.2001 → 05.2005	K4M 718	B	35
					1.8 16V (BG04, BG0B, BG0C, BG0V)	03.2001 → 05.2005	F4P 770	B	65
					1.8 16V (BG04, BG0B, BG0C, BG0V)	03.2001 → 05.2005	F4P 774	B	65

R

		Pos			Pos				
1.8 16V (BG06, BG0J, BG0M)	03.2001 → 12.2007	F4P 770	B	65	2.2 dCi (BG0F)	10.2001 → 08.2006	G9T 702	D	94
<b>LAGUNA II Grandtour (KG0/1)</b>									
1.8 16V (BG06, BG0J, BG0M)	03.2001 → 12.2007	F4P 771	B	67	1.6	03.2001 → 10.2005	K4M 710	B	33
1.8 16V (BG06, BG0J, BG0M)	03.2001 → 12.2007	F4P 773	B	68	1.6 16V	02.2005 → 08.2007	K4M 716	B	34
1.8 16V (BG06, BG0J, BG0M)	03.2001 → 12.2007	F4P 774	B	65	1.6 16V (KG0A, KG0L)	03.2001 → 12.2007	K4M 710	B	33
1.8 16V (BG06, BG0J, BG0M)	03.2001 → 12.2007	F4P 775	B	67	1.6 16V (KG0A, KG0L)	03.2001 → 12.2007	K4M 714	B	33
1.8 16V (BG06, BG0J, BG0M)	03.2001 → 12.2007	F4P 770	B	65	1.6 Bifuel	06.2005 → 12.2007	K4M 714	B	33
1.8 16V (BG06, BG0J, BG0M)	03.2001 → 12.2007	F4P 772	B	67	1.8 16V	03.2001 → 05.2005	F4P 770	B	65
1.8 16V (BG0B, BG0C, BG0J, BG0M, BG0V)	03.2001 → 05.2005	F4P 770	B	65	1.8 16V	03.2001 → 05.2005	F4P 770	B	65
1.8 16V (BG0B, BG0C, BG0J, BG0M, BG0V)	03.2001 → 05.2005	F4P 772	B	67	1.8 16V (KG0B, KG0M)	03.2001 → 05.2005	F4P 770	B	65
1.8 16V (BG0B, BG0M)	03.2001 → 09.2007	F4P 770	B	65	1.8 16V (KG0B, KG0M)	03.2001 → 05.2005	F4P 773	B	68
1.8 16V (BG0B, BG0M)	03.2001 → 09.2007	F4P 773	B	68	1.8 16V (KG0J)	03.2001 → 05.2005	F4P 770	B	65
1.9 dCi (BG0E)	06.2001 → 05.2005	F9Q 752	D	50	1.8 16V (KG0J)	03.2001 → 05.2005	F4P 771	B	67
1.9 dCi	03.2001 → 09.2007	F9Q 718	D	50	1.8 16V (KG0J)	03.2001 → 05.2005	F4P 774	B	65
1.9 dCi	03.2001 → 09.2007	F9Q 754	D	50	1.8 16V (KG0J)	03.2001 → 05.2005	F4P 775	B	67
1.9 dCi	09.2005 → 12.2007	F9Q 750	D	50	1.9 dCi (KG0E)	06.2001 → 05.2005	F9Q 752	D	50
1.9 dCi (BG05)	03.2004 → 05.2005	F9Q 664	D	49	1.9 dCi	03.2001 → 12.2007	F9Q 754	D	50
1.9 dCi (BG08, BG0G)	03.2001 → 09.2007	F9Q 650	D	49	1.9 dCi	08.2003 → 09.2007	F9Q 664	D	49
1.9 dCi (BG08, BG0G)	03.2001 → 09.2007	F9Q 670	D	49	1.9 dCi	09.2005 → 12.2007	F9Q 750	D	50
1.9 dCi (BG08, BG0G)	03.2001 → 09.2007	F9Q 674	D	49	1.9 dCi (KG05)	03.2004 → 05.2005	F9Q 664	D	49
1.9 dCi (BG08, BG0G)	03.2001 → 09.2007	F9Q 750	D	50	1.9 dCi (KG0E, KG0R)	10.2001 → 05.2005	F9Q 752	D	50
1.9 dCi (BG0R)	10.2001 → 05.2005	F9Q 754	D	50	1.9 dCi (KG0G)	03.2001 → 09.2007	F9Q 670	D	49
1.9 dCi (BG12)	09.2005 → 12.2007	F9Q 750	D	50	1.9 dCi (KG0G)	03.2001 → 09.2007	F9Q 674	D	49
1.9 dCi (BG12)	09.2005 → 12.2007	F9Q 758	D	49	1.9 dCi (KG0G)	03.2001 → 09.2007	F9Q 750	D	50
1.9 dCi (BG12)	09.2005 → 12.2007	F9Q 759	D	49	1.9 dCi (KG12)	08.2005 → 09.2007	F9Q 758	D	49
1.9 dCi (BG1A, BG1V)	05.2005 → 08.2007	F9Q 758	D	49	1.9 dCi (KG12)	08.2005 → 09.2007	F9Q 759	D	49
1.9 dCi (BG1A, BG1V)	05.2005 → 08.2007	F9Q 759	D	49	1.9 dCi (KG1A, KG1W)	01.2005 → 12.2007	F9Q 674	D	49
1.9 dCi (BG1A, BG1W)	01.2005 → 08.2007	F9Q 674	D	49	1.9 dCi (KG1A, KG1W)	01.2005 → 12.2007	F9Q 758	D	49
1.9 dCi (BG1A, BG1W)	01.2005 → 08.2007	F9Q 758	D	49	1.9 dCi (KG1V)	05.2005 → 12.2007	F9Q 758	D	49
2.0 16V (BG00, BG0K, BG0P, BG0W)	08.2002 → 12.2007	F4R 712	B	65	1.9 dCi (KG1V)	05.2005 → 12.2007	F9Q 759	D	49
2.0 16V (BG00, BG0K, BG0P, BG0W)	08.2002 → 12.2007	F4R 713	B	65	2.0 16V (KG00, KG0K, KG0W, KG0P)	08.2002 → 12.2007	F4R 712	B	65
2.0 16V (BG00, BG0K, BG0P, BG0W)	08.2002 → 12.2007	F4R 714	B	65	2.0 16V (KG00, KG0K, KG0W, KG0P)	08.2002 → 12.2007	F4R 713	B	65
2.0 16V (BG00, BG0K, BG0P, BG0W)	08.2002 → 12.2007	F4R 715	B	65	2.0 16V (KG00, KG0K, KG0W, KG0P)	08.2002 → 12.2007	F4R 714	B	65
2.0 16V (BG00, BG0W, BG0K, BG0P)	08.2002 → 12.2006	F4R 712	B	65	2.0 16V (KG00, KG0K, KG0W, KG0P)	08.2002 → 12.2007	F4R 715	B	65
2.0 16V (BG00, BG0W, BG0K, BG0P)	08.2002 → 12.2006	F4R 713	B	65	2.0 16V (KG00, KG0K, KG0W, KG0P)	10.2004 → 09.2007	F4R 712	B	65
2.0 16V (BG00, BG0W, BG0K, BG0P)	08.2002 → 12.2006	F4R 714	B	65	2.0 16V (KG00, KG0K, KG0W, KG0P)	10.2004 → 09.2007	F4R 713	B	65
2.0 16V (BG00, BG0W, BG0K, BG0P)	08.2002 → 12.2006	F4R 715	B	65	2.0 16V (KG00, KG0K, KG0W, KG0P)	10.2004 → 09.2007	F4R 714	B	65
2.0 16V (BG03, BG0Z, BG0T, BG1Y)	01.2005 → 09.2007	F4R 784	B	65	2.0 16V (KG00, KG0K, KG0W, KG0P)	10.2004 → 09.2007	F4R 715	B	65
2.0 16V (BG03, BG0Z, BG0T, BG1Y)	01.2005 → 09.2007	F4R 786	B	65	2.0 16V (KG03, KG0Z, KG0T, KG1Y)	01.2005 → 09.2007	F4R 784	B	65
2.0 16V (BG03, BG0Z, BG0T, BG1Y)	01.2005 → 09.2007	F4R 787	B	65	2.0 16V (KG03, KG0Z, KG0T, KG1Y)	01.2005 → 09.2007	F4R 786	B	65
2.0 16V (BG1Y)	01.2005 → 09.2007	F4R 886	B	65	2.0 16V (KG03, KG0Z, KG0T, KG1Y)	01.2005 → 09.2007	F4R 787	B	65
2.0 16V (BG1Y)	01.2005 → 09.2007	F4R 887	B	65	2.0 16V (KG1Y)	01.2005 → 09.2007	F4R 886	B	65
2.0 16V IDE (BG0N)	04.2001 → 09.2007	F5R 700	B	66	2.0 16V (KG1Y)	01.2005 → 09.2007	F4R 887	B	65
2.0 16V IDE (BG0N)	04.2001 → 09.2007	F5R 701	B	66	2.0 16V IDE (KG0N)	04.2001 → 09.2007	F5R 700	B	66
2.0 16V Turbo (BG0S, BG1L, BG1M)	01.2003 → 03.2005	F4R 764	B	65	2.0 16V IDE (KG0N)	04.2001 → 09.2007	F5R 701	B	66
2.0 16V Turbo (BG0S, BG1L, BG1M)	01.2003 → 03.2005	F4R 765	B	65	2.0 16V Turbo (KG0S, KG1L, KG03)	01.2003 → 08.2005	F4R 764	B	65
2.0 dCi (BG14, BG1S)	01.2006 → 08.2007	M9R 760	D	73	2.0 16V Turbo (KG0S, KG1L, KG03)	01.2003 → 08.2005	F4R 765	B	65
2.0 dCi (BG1T)	08.2005 → 08.2006	M9R 740	D	73	2.0 dCi (KG1S)	01.2006 → 12.2007	M9R 760	D	73
2.2 dCi	05.2005 → 08.2007	G9T 600	D	94	2.0 dCi (KG1T)	08.2005 → 08.2006	M9R 740	D	73
2.2 dCi	05.2005 → 08.2007	G9T 605	D	94	2.2 dCi	05.2005 → 12.2007	G9T 600	D	94
2.2 dCi	05.2005 → 08.2007	G9T 706	D	94	2.2 dCi	05.2005 → 12.2007	G9T 706	D	94
2.2 dCi	05.2005 → 08.2007	G9T 707	D	94	2.2 dCi	05.2005 → 12.2007	G9T 707	D	94
2.2 dCi (BG09)	04.2004 → 10.2005	G9T 600	D	94	2.2 dCi (KG09)	04.2004 → 10.2005	G9T 600	D	94
2.2 dCi (BG0F)	10.2001 → 08.2006	G9T 700	D	94	2.2 dCi (KG0F)	10.2001 → 08.2006	G9T 702	D	94
<b>LAGUNA III (BT0/1)</b>									

		Pos			Pos
1.5 dCi (BT00, BT0A, BT0T, BT1J) 10.2007 → 12.2015	K9K 780	D 19	2.0 dCi GT (BT11, BT1E, 03.2008 → 12.2015 BT1N)	M9R 816	D 73
1.5 dCi (BT00, BT0A, BT0T, BT1J) 10.2007 → 12.2015	K9K 782	D 21	2.0 dCi GT (BT11, BT1E, 03.2008 → 12.2015 BT1N)	M9R 820	D 73
1.5 dCi (BT00, BT0A, BT0T, BT1J) 10.2007 → 12.2015	K9K 846	D 25	2.0 dCi GT (BT11, BT1E, 03.2008 → 12.2015 BT1N)	M9R 828	D 75
1.6 16V (BT04, BT0D, BT0U) 10.2007 → 12.2015	K4M 824	B 36	<b>LAGUNA III Grandtour (KT0/1)</b>		
2.0 16V Turbo 10.2007 → 12.2015	F4R 811	B 65	1.5 dCi (KT0A) 10.2007 → 12.2015	K9K 780	D 19
2.0 GT 03.2008 → 12.2015	F4R 800	B 65	1.5 dCi (KT0A) 10.2007 → 12.2015	K9K 782	D 21
2.0 dCi (BT01, BT08, BT09, BT0E, BT0K, BT12, BT1C, BT1D,...) 10.2007 → 12.2015	M9R 742	D 73	1.5 dCi (KT0A) 10.2007 → 12.2015	K9K 846	D 25
2.0 dCi (BT01, BT08, BT09, BT0E, BT0K, BT12, BT1C, BT1D,...) 10.2007 → 12.2015	M9R 744	D 73	1.6 16V (KT0D) 10.2007 → 12.2015	K4M 824	B 36
2.0 dCi (BT01, BT08, BT09, BT0E, BT0K, BT12, BT1C, BT1D,...) 10.2007 → 12.2015	M9R 746	D 73	2.0 16V Turbo 10.2007 → 12.2015	F4R 811	B 65
2.0 dCi (BT01, BT08, BT09, BT0E, BT0K, BT12, BT1C, BT1D,...) 10.2007 → 12.2015	M9R 748	D 73	2.0 GT 03.2008 → 12.2015	F4R 800	B 65
2.0 dCi (BT01, BT08, BT09, BT0E, BT0K, BT12, BT1C, BT1D,...) 10.2007 → 12.2015	M9R 754	D 78	2.0 dCi (KT01, KT08, KT09, KT0K, KT12, KT1D, KT1W) 10.2007 → 12.2015	M9R 742	D 73
2.0 dCi (BT01, BT08, BT09, BT0E, BT0K, BT12, BT1C, BT1D,...) 10.2007 → 12.2015	M9R 802	D 73	2.0 dCi (KT01, KT08, KT09, KT0K, KT12, KT1D, KT1W) 10.2007 → 12.2015	M9R 744	D 73
2.0 dCi (BT01, BT08, BT09, BT0E, BT0K, BT12, BT1C, BT1D,...) 10.2007 → 12.2015	M9R 805	D 73	2.0 dCi (KT01, KT08, KT09, KT0K, KT12, KT1D, KT1W) 10.2007 → 12.2015	M9R 802	D 73
2.0 dCi (BT01, BT08, BT09, BT0E, BT0K, BT12, BT1C, BT1D,...) 10.2007 → 12.2015	M9R 808	D 78	2.0 dCi (KT01, KT08, KT09, KT0K, KT12, KT1D, KT1W) 10.2007 → 12.2015	M9R 805	D 73
2.0 dCi (BT01, BT08, BT09, BT0E, BT0K, BT12, BT1C, BT1D,...) 10.2007 → 12.2015	M9R 814	D 73	2.0 dCi (KT01, KT08, KT09, KT0K, KT12, KT1D, KT1W) 10.2007 → 12.2015	M9R 808	D 78
2.0 dCi (BT01, BT08, BT09, BT0E, BT0K, BT12, BT1C, BT1D,...) 10.2007 → 12.2015	M9R 845	D 79	2.0 dCi (KT01, KT08, KT09, KT0K, KT12, KT1D, KT1W) 10.2007 → 12.2015	M9R 814	D 73
2.0 dCi (BT01, BT08, BT09, BT0E, BT0K, BT12, BT1C, BT1D,...) 10.2007 → 12.2015	M9R 854	D 75	2.0 dCi (KT01, KT08, KT09, KT0K, KT12, KT1D, KT1W) 10.2007 → 12.2015	M9R 845	D 79
2.0 dCi (BT01, BT08, BT09, BT0E, BT0K, BT12, BT1C, BT1D,...) 10.2007 → 12.2015	M9R 858	D 75	2.0 dCi (KT01, KT08, KT09, KT0K, KT12, KT1D, KT1W) 10.2007 → 12.2015	M9R 854	D 75
2.0 dCi (BT07, BT0J, BT14, BT1A, BT1S) 10.2007 → 12.2015	M9R 742	D 73	2.0 dCi (KT01, KT08, KT09, KT0K, KT12, KT1D, KT1W) 10.2007 → 12.2015	M9R 858	D 75
2.0 dCi (BT07, BT0J, BT14, BT1A, BT1S) 10.2007 → 12.2015	M9R 744	D 73	2.0 dCi (KT07, KT0J, KT14, KT1A, KT1S) 10.2007 → 12.2015	M9R 814	D 73
2.0 dCi (BT07, BT0J, BT14, BT1A, BT1S) 10.2007 → 12.2015	M9R 802	D 73	2.0 dCi (KT07, KT0J, KT14, KT1A, KT1S) 10.2007 → 12.2015	M9R 814	D 73
2.0 dCi (BT07, BT0J, BT14, BT1A, BT1S) 10.2007 → 12.2015	M9R 814	D 73	2.0 dCi (KT07, KT0J, KT14, KT1A, KT1S) 10.2007 → 12.2015	M9R 854	D 75
2.0 dCi (BT07, BT0J, BT14, BT1A, BT1S) 10.2007 → 12.2015	M9R 854	D 75	2.0 dCi (KT07, KT0J, KT14, KT1A, KT1S) 10.2007 → 12.2015	M9R 858	D 75
2.0 dCi (BT07, BT0J, BT14, BT1A, BT1S) 10.2007 → 12.2015	M9R 858	D 75	2.0 dCi (KT07, KT0J, KT14, KT1A, KT1S) 10.2007 → 12.2015	M9R 800	D 73
2.0 dCi (BT0M, BT0N, BT0S, BT19, BT1F) 01.2008 → 12.2015	M9R 800	D 73	2.0 dCi (KT0M, KT0N, KT0S, KT19, KT1F) 01.2008 → 12.2015	M9R 806	D 74
2.0 dCi (BT0M, BT0N, BT0S, BT19, BT1F) 01.2008 → 12.2015	M9R 806	D 74	2.0 dCi (KT0M, KT0N, KT0S, KT19, KT1F) 01.2008 → 12.2015	M9R 806	D 74
2.0 dCi (BT0M, BT0N, BT0S, BT19, BT1F) 01.2008 → 12.2015	M9R 809	D 73	2.0 dCi (KT0M, KT0N, KT0S, KT19, KT1F) 01.2008 → 12.2015	M9R 809	D 73
2.0 dCi (BT0M, BT0N, BT0S, BT19, BT1F) 01.2008 → 12.2015	M9R 815	D 73	2.0 dCi (KT0M, KT0N, KT0S, KT19, KT1F) 01.2008 → 12.2015	M9R 809	D 73
2.0 dCi (BT0M, BT0N, BT0S, BT19, BT1F) 01.2008 → 12.2015	M9R 854	D 75	2.0 dCi (KT0M, KT0N, KT0S, KT19, KT1F) 01.2008 → 12.2015	M9R 815	D 73
2.0 dCi (BT0M, BT0N, BT0S, BT19, BT1F) 01.2008 → 12.2015	M9R 857	D 75	2.0 dCi (KT0M, KT0N, KT0S, KT19, KT1F) 01.2008 → 12.2015	M9R 849	D 79
2.0 dCi (BT0M, BT0N, BT0S, BT19, BT1F) 01.2008 → 12.2015	M9R 854	D 75	2.0 dCi (KT0M, KT0N, KT0S, KT19, KT1F) 01.2008 → 12.2015	M9R 854	D 75
2.0 dCi (BT0M, BT0N, BT0S, BT19, BT1F) 01.2008 → 12.2015	M9R 857	D 75	2.0 dCi (KT0M, KT0N, KT0S, KT19, KT1F) 01.2008 → 12.2015	M9R 857	D 75
2.0 dCi (BT0M, BT0N, BT0S, BT19, BT1F) 01.2008 → 12.2015	M9R 858	D 75	2.0 dCi (KT0M, KT0N, KT0S, KT19, KT1F) 01.2008 → 12.2015	M9R 858	D 75
2.0 dCi (BT0M, BT0N, BT0S, BT19, BT1F) 01.2008 → 12.2015	M9R 858	D 75	2.0 dCi GT (KT11, KT1E, 03.2008 → 12.2015 KT1N)	M9R 816	D 73
2.0 dCi (BT0M, BT0N, BT0S, BT19, BT1F) 01.2008 → 12.2015	M9R 858	D 75	2.0 dCi GT (KT11, KT1E, 03.2008 → 12.2015 KT1N)	M9R 820	D 73

**R**

		Pos			Pos				
2.0 dCi GT (KT11, KT1E, 03.2008 → 12.2015 KT1N)	M9R 828	D	75	1.2 16V LPG	11.2013 →	D4F 734	B	5	
<b>LATITUDE (L70_)</b>				1.5 dCi	12.2013 →	K9K 612	D	21	
1.5 dCi (L70R, L731)	07.2010 →	K9K 782	D	21	1.5 dCi	12.2013 →	K9K 838	D	21
2.0 dCi 130	12.2013 →	M9R 756	D	81	1.6	11.2013 →	K4M 842	B	35
2.0 dCi 150 (L70H)	02.2011 →	M9R 824	D	73	1.6	11.2013 →	K4M 845	B	35
2.0 dCi 150 (L70H)	02.2011 →	M9R 846	D	75	1.6 (L8A9, L8J0)	04.2014 →	K4M 842	B	35
2.0 dCi 175 (L70Y)	05.2011 →	M9R 804	D	73	1.6 (L8A9, L8J0)	04.2014 →	K4M 845	B	35
2.0 dCi 175 (L70Y)	05.2011 →	M9R 817	D	73	<b>MEGANE CC (EZ0/1_)</b>				
2.0 dCi 175 (L70Y)	05.2011 →	M9R 844	D	79	1.2 TCe	09.2012 → 08.2015	H5F 400	B	10
<b>LODGY (JS_)</b>				1.2 TCe (EZ16)	01.2013 →	H5F 404	B	10	
1.5 dCi	01.2015 →	K9K 830	D	25	1.5 dCi (EZ09, EZ1G, EZ0D)	06.2010 →	K9K 837	D	21
1.5 dCi	04.2015 → 12.2019	K9K 846	D	25	1.5 dCi (EZ0B, EZ07)	11.2013 → 08.2015	K9K 832	D	21
1.6	07.2013 →	K4M 845	B	35	1.6 16V (EZ0U, EZ1U)	06.2010 →	K4M 858	B	35
<b>LOGAN I (LS_)</b>				1.6 16V Hi-Flex	06.2010 →	K4M 866	B	35	
1.4	09.2004 →	K7J 710	B	32	1.6 dCi (EZ00)	04.2011 →	R9M 402	D	52
1.5 dCi	04.2007 →	K9K 792	D	24	2.0 TCe (EZ1T)	06.2010 →	F4R 870	B	68
1.5 dCi	02.2008 → 06.2015	K9K 796	D	24	2.0 TCe (EZ1T)	06.2010 →	F4R 872	B	68
1.5 dCi	06.2011 →	K9K 700	D	18	2.0 dCi (EZ0L)	06.2010 →	M9R 610	D	73
1.5 dCi	06.2011 →	K9K 790	D	26	<b>MEGANE CC III</b>				
1.5 dCi	06.2011 →	K9K 794	D	24	1.6 dCi	04.2011 →	R9M 402	D	52
1.6	09.2004 →	K7M 710	B	32	1.6 dCi	04.2011 →	R9M 404	D	52
1.6	02.2007 → 09.2010	K4M 706	B	33	<b>MEGANE CLASSIC</b>				
1.6	04.2007 →	K4M 690	B	33	2.0i 16V	09.2001 → 08.2003	F4R 740	B	65
1.6	04.2007 →	K4M 697	AB	38	2.0i 16V	09.2001 → 08.2003	F4R 741	B	65
1.6	05.2008 →	K7M 710	B	32	2.0i 16V	09.2001 → 08.2003	F4R 746	B	65
1.6	05.2008 →	K7M 718	B	32	2.0i 16V	09.2001 → 08.2003	F4R 747	B	65
1.6 (LS0L, LS09, LS0V, LS0P, LS18, LS1S, LS1V, LS1Y,...	04.2007 → 10.2013	K4M 690	B	33	<b>MEGANE GRANDTOUR</b>				
1.6 (LS0L, LS09, LS0V, LS0P, LS18, LS1S, LS1V, LS1Y,...	04.2007 → 10.2013	K4M 694	AB	39	1.9 TD	03.1999 → 08.2003	F8Q 784	D	41
1.6 (LS0L, LS09, LS0V, LS0P, LS18, LS1S, LS1V, LS1Y,...	04.2007 → 10.2013	K4M 696	B	35	1.9 TD	03.1999 → 08.2003	F8Q 786	D	44
1.6 (LS0L, LS09, LS0V, LS0P, LS18, LS1S, LS1V, LS1Y,...	04.2007 → 10.2013	K4M 697	AB	38	1.9 dCi	03.1999 → 02.2001	F9Q 732	D	50
1.6 (LS0L, LS09, LS0V, LS0P, LS18, LS1S, LS1V, LS1Y,...	04.2007 → 10.2013	K4M 698	B	33	1.9 dCi	03.1999 → 02.2001	F9Q 733	D	50
1.6 Flex (LS1V, LS09)	07.2007 → 09.2013	K4M 694	AB	39	1.9 dCi	03.1999 → 02.2001	F9Q 738	D	51
1.6 Flex (LS1V, LS09)	07.2007 → 09.2013	K4M 697	AB	38	1.9 dCi	03.1999 → 02.2001	F9Q 744	D	51
1.6 Flex (LS1V, LS09)	07.2007 → 09.2013	K4M 698	B	33	1.9 dCi	03.1999 → 02.2001	F9Q 800	D	51
<b>LOGAN I Estate (KS_)</b>				1.9 dCi	03.1999 → 02.2001	F9Q 803	D	49	
1.4	10.2007 →	K7J 710	B	32	1.9 dCi	03.1999 → 02.2001	F9Q 804	D	51
1.5 dCi	04.2007 →	K9K 792	D	24	1.9 dCi	03.1999 → 02.2001	F9Q 808	D	49
1.5 dCi	02.2008 → 06.2015	K9K 796	D	24	1.9 dCi	03.1999 → 02.2001	F9Q 816	D	49
1.5 dCi	06.2011 →	K9K 612	D	21	1.9 dCi	03.1999 → 02.2001	F9Q 818	D	49
1.6	04.2007 →	K7M 710	B	32	1.9 dCi	03.1999 → 02.2001	F9Q E 804	D	51
1.6 (KS0L, KS0M, KS0P, KS1S)	04.2007 →	K4M 690	B	33	1.9 dCi	03.1999 → 02.2001	F9Q EE 804	D	51
1.6 (KS0L, KS0M, KS0P, KS1S)	04.2007 →	K4M 696	B	35	1.9 dCi	03.1999 → 02.2001	F9Q J 803	D	49
1.6 (KS0L, KS0M, KS0P, KS1S)	04.2007 →	K4M 697	AB	38	2.0i	03.1999 → 08.2003	F3R 750	B	60
<b>LOGAN II Estate (K8_)</b>				2.0i	03.1999 → 08.2003	F3R 751	B	60	
1.2 16V	12.2013 →	D4F 732	B	5	2.0i	03.1999 → 08.2003	F3R 752	B	60
1.2 16V	12.2013 →	D4F 734	B	5	2.0i	03.1999 → 08.2003	F3R 791	B	60
1.2 16V LPG	12.2013 →	D4F 732	B	5	2.0i	03.1999 → 08.2003	F3R 796	B	61
1.2 16V LPG	12.2013 →	D4F 734	B	5	2.0i	03.1999 → 08.2003	F3R 797	B	60
1.5 dCi	12.2013 →	K9K 612	D	21	2.0i	03.1999 → 08.2003	F3R 798	B	61
1.5 dCi	12.2013 →	K9K 838	D	21	2.0i 16V	09.2001 → 08.2003	F4R 740	B	65
<b>LOGAN Pickup (US_)</b>				2.0i 16V	09.2001 → 08.2003	F4R 741	B	65	
1.6 16V (US1Y)	01.2010 → 08.2013	K4M 690	B	33	2.0i 16V	09.2001 → 08.2003	F4R 746	B	65
<b>LOGAN/STEPWAY II (L8_)</b>				2.0i 16V	09.2001 → 08.2003	F4R 747	B	65	
1.0 Hi-Flex (L8A0)	10.2013 → 12.2016	D4D 754	B	5	<b>MEGANE GRANDTOUR II</b>				
1.2	11.2013 →	D4F 732	B	5	1.4i 16V	08.2003 → 05.2009	K4J 730	B	33
1.2 16V LPG	11.2013 →	D4F 732	B	5	1.4i 16V	08.2003 → 05.2009	K4J 740	B	33
					1.5 dCi	08.2003 → 05.2009	K9K 722	D	18
					1.5 dCi	02.2004 → 05.2009	K9K 728	D	18
					1.5 dCi	02.2004 → 05.2009	K9K 729	D	18
					1.5 dCi	05.2005 → 05.2009	K9K 724	D	19
					1.5 dCi	05.2005 → 05.2009	K9K 732	D	19
					1.5 dCi	05.2005 → 05.2009	K9K P 732	D	23
					1.5 dCi	01.2006 → 11.2008	K9K 734	D	19
					1.6i 16V	08.2003 → 05.2009	K4M 760	B	34
					1.6i 16V	08.2003 → 05.2009	K4M 761	B	34
					1.6i 16V	02.2008 → 05.2009	K4M 762	B	34
					1.9 dCi	08.2003 → 05.2009	F9Q 800	D	51
					1.9 dCi	03.2004 → 05.2009	F9Q 808	D	49



				Pos					Pos
1.9 dCi	05.2005 → 05.2009	F9Q 803	D	49	2.0	05.1998 → 05.2001	F3R 798	B	61
1.9 dCi	05.2005 → 05.2009	F9Q 804	D	51	2.0 16V (BA0H)	07.1996 → 08.2003	F7R 710	B	62
1.9 dCi	05.2005 → 05.2009	F9Q 818	D	49	2.0 16V (BA0H)	07.1996 → 08.2003	F7R 714	B	62
1.9 dCi	05.2005 → 05.2009	F9Q E 804	D	51	2.0 i	03.1999 → 08.2003	F3R 750	B	60
1.9 dCi	05.2005 → 05.2009	F9Q EE 804	D	51	2.0 i	03.1999 → 08.2003	F3R 751	B	60
1.9 dCi	05.2005 → 05.2009	F9Q J 803	D	49	2.0 i (BA0G)	01.1996 → 08.2003	F3R 750	B	60
2.0i 16V	08.2003 → 05.2009	F4R 770	B	65	2.0 i (BA0G)	01.1996 → 08.2003	F3R 751	B	60
2.0i 16V	08.2003 → 05.2009	F4R 771	B	65	<b>MEGANE I Cabriolet (EA0/1 )</b>				
<b>MEGANE I (BA0/1 )</b>					1.4 16V (EA0D, EA1H, EA0W, EA10)	03.1999 → 08.2003	K4J 714	B	33
1.4 16V (BA0D, BA1H, BA0W, BA10)	03.1999 → 08.2003	K4J 714	B	33	1.4 16V (EA0D, EA1H, EA0W, EA10)	03.1999 → 08.2003	K4J 750	B	33
1.4 16V (BA0D, BA1H, BA0W, BA10)	03.1999 → 08.2003	K4J 750	B	33	1.6 16V (EA04, EA0B, EA11, EA1J)	03.1999 → 07.2003	K4M 700	B	33
1.4 Eco (BA0T)	01.1996 → 03.1999	E7J 624	B	16	1.6 16V (EA04, EA0B, EA11, EA1J)	03.1999 → 07.2003	K4M 701	B	33
1.4 e (BA0E, BA0V)	01.1996 → 08.2003	E7J 626	B	16	1.6 16V (EA04, EA0B, EA11, EA1J)	03.1999 → 07.2003	K4M 708	B	33
1.4 e (BA0E, BA0V)	01.1996 → 08.2003	E7J 764	B	16	1.6 16V (EA04, EA0B, EA11, EA1J)	03.1999 → 07.2003	K4M 709	B	33
1.6 16V	11.2001 → 12.2004	K4M 700	B	33	1.6 e (EA0F)	10.1996 → 03.1999	K7M 702	B	32
1.6 16V (BA04, BA0B, BA11, BA1J, BA16, BA19, BA1K, BA1V,...)	03.1999 → 08.2002	K4M 700	B	33	1.6 e (EA0F)	10.1996 → 03.1999	K7M 703	B	32
1.6 16V (BA04, BA0B, BA11, BA1J, BA16, BA19, BA1K, BA1V,...)	03.1999 → 08.2002	K4M 701	B	33	2.0 (EA0G)	04.1997 → 08.2003	F3R 750	B	60
1.6 16V (BA04, BA0B, BA11, BA1J, BA16, BA19, BA1K, BA1V,...)	03.1999 → 08.2002	K4M 706	B	33	2.0 (EA0G)	04.1997 → 08.2003	F3R 798	B	61
1.6 16V (BA04, BA0B, BA11, BA1J, BA16, BA19, BA1K, BA1V,...)	03.1999 → 08.2002	K4M 708	B	33	2.0 16V	08.1997 → 11.2000	F7R 714	B	62
1.6 16V (BA04, BA0B, BA11, BA1J, BA16, BA19, BA1K, BA1V,...)	03.1999 → 08.2002	K4M 709	B	33	2.0 16V	01.2002 → 08.2003	F4R 746	B	65
1.6 LPG	08.1995 → 03.1999	K7M 702	B	32	2.0 16V	01.2002 → 08.2003	F4R 770	B	65
1.6 LPG	10.2000 → 08.2002	K4M 704	B	33	2.0 16V (EA0H)	10.1996 → 11.1999	F7R 710	B	62
1.6 LPG	10.2000 → 08.2002	K4M 712	B	33	2.0 16V (EA0H)	10.1996 → 11.1999	F7R 714	B	62
1.6 e (BA0F, BA0S)	01.1996 → 03.1999	K7M 702	B	32	2.0 16V IDE (EA03, EA0P, EA14)	11.1999 → 08.2003	F5R 740	B	66
1.6 e (BA0F, BA0S)	01.1996 → 03.1999	K7M 703	B	32	2.0 i (EA0G)	03.1999 → 08.2003	F3R 791	B	60
1.6 e (BA0F, BA0S)	01.1996 → 03.1999	K7M 790	B	32	2.0 i (EA0G)	03.1999 → 08.2003	F3R 796	B	61
1.6 i (BA0L)	01.1996 → 03.1999	K7M 720	B	32	<b>MEGANE I Classic (LA0/1 )</b>				
1.8 16V (BA06, BA12, BA1A, BA1M, BA1R)	01.2001 → 08.2003	F4P 720	B	65	1.4 (LA0E, LA0V)	09.1996 → 08.2003	E7J 626	B	16
1.8 16V (BA06, BA12, BA1A, BA1M, BA1R)	01.2001 → 08.2003	F4P 722	B	65	1.4 (LA0E, LA0V)	09.1996 → 08.2003	E7J 764	B	16
1.9 D	04.1996 → 02.2001	F8Q 784	D	41	1.4 16V (LA0D, LA1H, IA0W, LA10)	03.1999 → 08.2003	K4J 714	B	33
1.9 D Eco (BA0A, BA0U, BA0R)	01.1996 → 08.2003	F8Q 620	D	42	1.4 16V (LA0D, LA1H, IA0W, LA10)	03.1999 → 08.2003	K4J 750	B	33
1.9 D Eco (BA0A, BA0U, BA0R)	01.1996 → 08.2003	F8Q 622	D	41	1.6	02.2000 → 09.2000	K7M 704	B	32
1.9 D Eco (BA0A, BA0U, BA0R)	01.1996 → 08.2003	F8Q 624	D	42	1.6 16V	01.1999 → 08.2008	K4M 706	B	33
1.9 DCi	03.1999 → 08.2003	F9Q 732	D	50	1.6 16V (LA00, LA04, LA0B, LA11, LA16, LA19, LA1J, LA1K,...)	03.1999 → 07.2003	K4M 700	B	33
1.9 DCi	03.1999 → 08.2003	F9Q 738	D	51	1.6 16V (LA00, LA04, LA0B, LA11, LA16, LA19, LA1J, LA1K,...)	03.1999 → 07.2003	K4M 701	B	33
1.9 DTi	02.2000 → 09.2000	F9Q 730	D	46	1.6 16V (LA00, LA04, LA0B, LA11, LA16, LA19, LA1J, LA1K,...)	03.1999 → 07.2003	K4M 706	B	33
1.9 TDI	09.1996 → 08.2003	F8Q 784	D	41	1.6 16V (LA00, LA04, LA0B, LA11, LA16, LA19, LA1J, LA1K,...)	03.1999 → 07.2003	K4M 708	B	33
1.9 dCi (BA05, BA1F)	02.2001 → 08.2003	F9Q 732	D	50	1.6 e (LA0F, LA0S)	09.1996 → 03.1999	K7M 702	B	32
1.9 dCi (BA05, BA1F)	02.2001 → 08.2003	F9Q 733	D	50	1.6 e (LA0F, LA0S)	09.1996 → 03.1999	K7M 703	B	32
1.9 dT	08.1998 → 10.1999	F8Q 784	D	41	1.6 e (LA0F, LA0S)	09.1996 → 03.1999	K7M 790	B	32
1.9 dT (B/SA0K, B/SA0Y)	01.1996 → 08.2003	F8Q 784	D	41	1.6 i (LA0L)	09.1996 → 03.1999	K7M 720	B	32
1.9 dT (B/SA0K, B/SA0Y)	01.1996 → 08.2003	F8Q 786	D	44	1.8 16V (LA06, LA12, LA1A, LA1M, LA1R)	01.2001 → 08.2003	F4P 720	B	65
1.9 dTi (BA08, BA0N)	03.1997 → 02.2001	F9Q 730	D	46	1.8 16V (LA06, LA12, LA1A, LA1M, LA1R)	01.2001 → 08.2003	F4P 722	B	65
1.9 dTi (BA08, BA0N)	03.1997 → 02.2001	F9Q 731	D	46	1.9 D (LA0A, LA0U, LA0R)	09.1996 → 08.2003	F8Q 620	D	42
1.9 dTi (BA08, BA0N)	03.1997 → 02.2001	F9Q 734	D	46	1.9 D (LA0A, LA0U, LA0R)	09.1996 → 08.2003	F8Q 622	D	41
1.9 dTi (BA08, BA0N)	03.1997 → 02.2001	F9Q 736	D	46	1.9 D (LA0A, LA0U, LA0R)	09.1996 → 08.2003	F8Q 624	D	42
1.9 dTi (BA1U)	02.2001 → 08.2003	F9Q 744	D	51					
2.0	05.1998 → 05.2001	F3R 750	B	60					
2.0	05.1998 → 05.2001	F3R 751	B	60					
2.0	05.1998 → 05.2001	F3R 791	B	60					
2.0	05.1998 → 05.2001	F3R 796	B	61					
2.0	05.1998 → 05.2001	F3R 797	B	60					

R

		Pos			Pos
1.9 TDI 09.1996 → 08.2003	F8Q 784	D 41	2.0 i (DA0G) 03.1996 → 08.2003	F3R 751	B 60
1.9 dCi (LA05) 03.1999 → 07.2003	F9Q 732	D 50	2.0 i (DA0G) 03.1996 → 08.2003	F3R 798	B 61
1.9 dCi (LA05) 03.1999 → 07.2003	F9Q 733	D 50	<b>MEGANE I Grandtour (KA0/1_)</b>		
1.9 dCi (LA05, LA1F) 02.2001 → 08.2003	F9Q 732	D 50	1.4 16V (KA0D, KA1H, KA0W, KA10) 03.1999 → 08.2003	K4J 714	B 33
1.9 dCi (LA05, LA1F) 02.2001 → 08.2003	F9Q 733	D 50	1.4 16V (KA0D, KA1H, KA0W, KA10) 03.1999 → 08.2003	K4J 750	B 33
1.9 dCi (LA05, LA1F) 02.2001 → 08.2003	F9Q 738	D 51	1.4 e (KA0V) 03.1999 → 08.2003	E7J 626	B 16
1.9 dT 08.1998 → 10.1999	F8Q 784	D 41	1.6 16V (KA0B, KA04, KA11) 03.1999 → 08.2003	K4M 700	B 33
1.9 dT (LA0K, LA0Y) 09.1996 → 08.2003	F8Q 784	D 41	1.6 16V (KA0B, KA04, KA11) 03.1999 → 08.2003	K4M 701	B 33
1.9 dT (LA0K, LA0Y) 09.1996 → 08.2003	F8Q 786	D 44	1.6 16V (KA0B, KA04, KA11) 03.1999 → 08.2003	K4M 708	B 33
1.9 dTi (LA08, LA0N) 03.1997 → 02.2001	F9Q 730	D 46	1.6 16V (KA0B, KA04, KA11) 03.1999 → 08.2003	K4M 709	B 33
1.9 dTi (LA08, LA0N) 03.1997 → 02.2001	F9Q 731	D 46	1.6 16V (KA0B, KA04, KA11) 03.1999 → 08.2003	K4M 712	B 33
1.9 dTi (LA08, LA0N) 03.1997 → 02.2001	F9Q 734	D 46	1.6 Bifuel 03.1999 → 09.2000	K4M 704	B 33
1.9 dTi (LA08, LA0N) 03.1997 → 02.2001	F9Q 736	D 46	1.6 e (KA0F) 03.1999 → 08.2003	K7M 702	B 32
1.9 dTi (LA1U) 02.2001 → 08.2003	F9Q 744	D 51	1.6 e (KA0F) 03.1999 → 08.2003	K7M 703	B 32
2.0 05.1998 → 05.2001	F3R 750	B 60	1.8 16V (KA0S, KA12, KA1A, KA1M, KA1R) 01.2001 → 08.2003	F4P 720	B 65
2.0 05.1998 → 05.2001	F3R 752	B 60	1.8 16V (KA0S, KA12, KA1A, KA1M, KA1R) 01.2001 → 08.2003	F4P 722	B 65
2.0 05.1998 → 05.2001	F3R 791	B 60	1.9 D (KA0J, KA0R) 04.1999 → 08.2003	F8Q 622	D 41
2.0 05.1998 → 05.2001	F3R 796	B 61	1.9 D (KA0J, KA0R) 04.1999 → 08.2003	F8Q 790	D 45
2.0 05.1998 → 05.2001	F3R 797	B 60	1.9 dCi 03.1999 → 09.2000	F9Q 732	D 50
2.0 05.1998 → 05.2001	F3R 798	B 61	1.9 dCi (KA05, KA1F) 02.2001 → 08.2003	F9Q 732	D 50
2.0 01.2001 → 03.2006	F4R 740	B 65	1.9 dCi (KA05, KA1F) 02.2001 → 08.2003	F9Q 733	D 50
2.0 RT 03.2001 → 08.2003	F4R 747	B 65	1.9 dCi (KA05, KA1F) 02.2001 → 08.2003	F9Q 738	D 51
2.0 RT 03.2001 → 08.2003	F5R 740	B 66	1.9 dTi (KA0N) 03.1999 → 02.2001	F9Q 731	D 46
2.0 i (LA07, LA0G) 09.1996 → 08.2003	F3R 750	B 60	1.9 dTi (KA0N) 03.1999 → 02.2001	F9Q 736	D 46
2.0 i (LA07, LA0G) 09.1996 → 08.2003	F3R 751	B 60	1.9 dTi (KA1U) 02.2001 → 08.2003	F9Q 744	D 51
2.0 i (LA07, LA0G) 09.1996 → 08.2003	F3R 752	B 60	<b>MEGANE II (BM0/1_, CM0/1_)</b>		
2.0 i (LA07, LA0G) 09.1996 → 08.2003	F3R 791	B 60	1.4 16V 10.2003 → 02.2008	K4J 732	B 33
2.0 i (LA07, LA0G) 09.1996 → 08.2003	F3R 796	B 61	1.4 16V (BM0B, CM0B) 11.2002 → 02.2008	K4J 730	B 33
2.0 i (LA07, LA0G) 09.1996 → 08.2003	F3R 797	B 60	1.4 16V (BM0B, CM0B) 11.2002 → 02.2008	K4J 740	B 33
2.0 i (LA07, LA0G) 09.1996 → 08.2003	F3R 798	B 61	1.5 dCi (BM02, BM13, BM2A, CM02, CM13) 10.2003 → 02.2008	K9K 728	D 18
2.0 i (LA0G) 03.1999 → 08.2003	F3R 750	B 60	1.5 dCi (BM02, BM13, BM2A, CM02, CM13) 10.2003 → 02.2008	K9K 729	D 18
2.0 i (LA0G) 03.1999 → 08.2003	F3R 751	B 60	1.5 dCi (BM0F, BM0T, BM2B, CM0F, CM0T) 09.2002 → 02.2008	K9K 722	D 18
2.0 i (LA0G) 03.1999 → 08.2003	F3R 752	B 60	1.5 dCi (BM16, CM16) 01.2007 → 03.2009	K9K 734	D 19
2.0 i (LA0G) 03.1999 → 08.2003	F3R 791	B 60	1.5 dCi (BM1E, CM1E) 05.2005 → 06.2008	K9K 732	D 19
2.0 i (LA0G) 03.1999 → 08.2003	F3R 796	B 61	1.5 dCi (BM1F, CM1F) 05.2005 → 02.2008	K9K 724	D 19
2.0 i (LA0G) 03.1999 → 08.2003	F3R 797	B 60	1.6 06.2005 → 02.2008	K4M 788	B 34
2.0 i (LA0G) 03.1999 → 08.2003	F3R 798	B 61	1.6 16V 01.2006 → 06.2008	K4M 760	B 34
<b>MEGANE I Coach (DA0/1_)</b>			1.6 16V 01.2006 → 06.2008	K4M 812	B 36
1.4 16V (DA0D, DA1H, DA0W, DA10) 03.1999 → 07.2003	K4J 700	B 34	1.6 16V 01.2006 → 06.2008	K4M 813	B 36
1.4 16V (DA0D, DA1H, DA0W, DA10) 03.1999 → 07.2003	K4J 714	B 33	1.6 16V (BM0C, CM0C) 11.2002 → 02.2008	K4M 760	B 34
1.4 16V (DA0D, DA1H, DA0W, DA10) 03.1999 → 07.2003	K4J 750	B 33	1.6 Bifuel 06.2005 → 02.2008	K4M 788	B 34
1.6 16V (DA0B, DA04, DA11) 03.1999 → 07.2003	K4M 700	B 33	1.6 Flex-Fuel 01.2007 → 02.2008	K4M 788	B 34
1.6 16V (DA0B, DA04, DA11) 03.1999 → 07.2003	K4M 701	B 33	1.9 dCi 11.2002 → 12.2005	F9Q 808	D 49
1.6 16V (DA0B, DA04, DA11) 03.1999 → 07.2003	K4M 708	B 33	1.9 dCi 11.2002 → 02.2008	F9Q 804	D 51
1.6 16V (DA0B, DA04, DA11) 03.1999 → 07.2003	K4M 709	B 33	1.9 dCi 11.2002 → 02.2008	F9Q 816	D 49
1.6 e (DA0F) 03.1996 → 03.1999	K7M 702	B 32	1.9 dCi 11.2002 → 02.2008	F9Q 818	D 49
1.6 e (DA0F) 03.1996 → 03.1999	K7M 703	B 32	1.9 dCi 03.2004 → 08.2006	F9Q 808	D 49
1.9 DCi 03.1999 → 09.2000	F9Q 732	D 50	1.9 dCi 05.2005 → 02.2008	F9Q 804	D 51
1.9 DCi 03.1999 → 09.2000	F9Q 733	D 50	1.9 dCi 05.2005 → 02.2008	F9Q 818	D 49
1.9 dCi (DA05, DA1F) 02.2001 → 08.2003	F9Q 732	D 50	1.9 dCi 05.2005 → 12.2009	F9Q 803	D 49
1.9 dCi (DA05, DA1F) 02.2001 → 08.2003	F9Q 733	D 50	1.9 dCi 05.2005 → 12.2009	F9Q 804	D 51
1.9 dTi (DA0N) 03.1997 → 02.2001	F9Q 731	D 46	1.9 dCi 05.2005 → 12.2009	F9Q 816	D 49
1.9 dTi (DA0N) 03.1997 → 02.2001	F9Q 734	D 46	1.9 dCi 05.2005 → 12.2009	F9Q 818	D 49
1.9 dTi (DA0N) 03.1997 → 02.2001	F9Q 736	D 46	1.9 dCi (BM0G, CM0G) 11.2002 → 02.2008	F9Q 800	D 51
2.0 16V 08.1997 → 11.2000	F7R 714	B 62	2.0 09.2003 → 12.2009	F4R 770	B 65
2.0 16V 01.2002 → 08.2003	F4R 746	B 65	2.0 09.2003 → 12.2009	F4R 771	B 65
2.0 16V (DA0H) 03.1996 → 11.1999	F7R 710	B 62	2.0 08.2006 → 02.2008	F4R 774	B 65
2.0 16V (DA0H) 03.1996 → 11.1999	F7R 714	B 62	2.0 16V (BM0U, CM0U) 11.2002 → 02.2008	F4R 770	B 65
2.0 16V IDE (DA03, DA0P, DA14) 11.1999 → 08.2003	F5R 740	B 66			
2.0 i 03.1999 → 08.2003	F3R 791	B 60			
2.0 i 03.1999 → 08.2003	F3R 796	B 61			
2.0 i (DA0G) 03.1996 → 08.2003	F3R 750	B 60			

R



				Pos					Pos
2.0 16V Turbo	05.2004 → 02.2008	F4R 776	B	65	<b>MEGANE II Saloon (LM0/1_)</b>				
2.0 16V Turbo	01.2009 → 12.2009	F4R 776	B	65	1.4	09.2003 →	K4J 730	B	33
2.0 Renault Sport	05.2004 → 10.2009	F4R 774	B	65	1.4	09.2003 →	K4J 732	B	33
2.0 Renault Sport	05.2004 → 10.2009	F4Rt 774	B	65	1.4	09.2003 →	K4J 740	B	33
2.0 dCi	01.2007 → 02.2008	M9R 724	D	73	1.5 dCi (LM02, LM13, LM2A)	02.2004 → 12.2010	K9K 728	D	18
2.0 dCi (BM1K, CM1K)	09.2005 → 02.2008	M9R 700	D	73	1.5 dCi (LM02, LM13, LM2A)	02.2004 → 12.2010	K9K 729	D	18
2.0 dCi (BM1K, CM1K)	09.2005 → 02.2008	M9R 722	D	73	1.5 dCi (LM0F, LM0T, LM2B)	08.2003 → 12.2010	K9K 722	D	18
<b>MEGANE II Coupé-Cabriolet (EM0/1_)</b>					1.5 dCi (LM16)	10.2003 → 12.2010	K9K 734	D	19
1.5 dCi (EM16)	01.2007 → 06.2009	K9K 734	D	19	1.5 dCi (LM1E)	05.2005 → 12.2010	K9K 732	D	19
1.5 dCi (EM1E)	03.2006 → 01.2009	K9K 732	D	19	1.5 dCi (LM1F)	05.2005 → 12.2010	K9K 724	D	19
1.6	09.2003 → 03.2009	K4M 760	B	34	1.6	09.2003 → 11.2008	K4M 760	B	34
1.6	09.2003 → 03.2009	K4M 761	B	34	1.6	09.2003 → 11.2008	K4M 761	B	34
1.6	06.2005 → 03.2009	K4M 788	B	34	1.6	09.2003 →	K4M 760	B	34
1.6 16V	01.2006 → 06.2008	K4M 760	B	34	1.6	09.2003 →	K4M 761	B	34
1.6 16V	01.2006 → 06.2008	K4M 761	B	34	1.6	09.2003 →	K4M 761	B	34
1.6 16V	01.2006 → 06.2008	K4M 812	B	36	1.6	09.2003 →	K4M 768	B	34
1.6 16V	01.2006 → 06.2008	K4M 813	B	36	1.6	05.2005 →	K4M 762	B	34
1.9 dCi	09.2003 → 03.2009	F9Q 800	D	51	1.6	09.2007 → 12.2010	K4M 812	B	36
1.9 dCi	09.2003 → 03.2009	F9Q 804	D	51	1.6 16V (LM1R, LM0C)	01.2006 →	K4M 760	B	34
1.9 dCi	09.2003 → 03.2009	F9Q 816	D	49	1.6 16V (LM1R, LM0C)	01.2006 →	K4M 761	B	34
1.9 dCi	09.2003 → 03.2009	F9Q 818	D	49	1.6 16V (LM1R, LM0C)	01.2006 →	K4M 812	B	36
1.9 dCi	05.2005 → 02.2007	F9Q 803	D	49	1.6 16V (LM1R, LM0C)	01.2006 →	K4M 813	B	36
1.9 dCi	05.2005 → 02.2007	F9Q 804	D	51	1.6 16V (LM1R, LM0C)	01.2006 →	K4M 813	B	36
1.9 dCi	05.2005 → 03.2009	F9Q 804	D	51	1.6 Hi-Flex	03.2006 →	K4M 766	B	35
1.9 dCi	05.2005 → 03.2009	F9Q 816	D	49	1.9 dCi	09.2003 → 12.2005	F9Q 808	D	49
1.9 dCi	05.2005 → 03.2009	F9Q 818	D	49	1.9 dCi	03.2004 →	F9Q 808	D	49
2.0	09.2003 → 02.2007	F4R 770	B	65	1.9 dCi	05.2005 →	F9Q 803	D	49
2.0	09.2003 → 02.2007	F4R 771	B	65	1.9 dCi	05.2005 →	F9Q 804	D	51
2.0	09.2003 → 12.2009	F4R 770	B	65	1.9 dCi	05.2005 →	F9Q 804	D	51
2.0	09.2003 → 12.2009	F4R 771	B	65	1.9 dCi (LM0G, LM1G, LM2C)	09.2003 →	F9Q 800	D	51
2.0 16V Turbo	05.2004 → 03.2009	F4R 776	B	65	1.9 dCi (LM14, LM1D)	05.2005 →	F9Q 803	D	49
2.0 dCi	09.2005 → 03.2009	M9R 700	D	73	1.9 dCi (LM14, LM1D)	05.2005 →	F9Q 804	D	51
2.0 dCi	09.2005 → 03.2009	M9R 722	D	73	1.9 dCi (LM14, LM1D)	05.2005 →	F9Q 816	D	49
<b>MEGANE II Estate (KM0/1_)</b>					1.9 dCi (LM14, LM1D)	05.2005 →	F9Q 818	D	49
1.4	08.2003 → 07.2009	K4J 730	B	33	2.0	09.2003 → 12.2007	F4R 770	B	65
1.4	08.2003 → 07.2009	K4J 740	B	33	2.0	09.2003 →	F4R 770	B	65
1.5 dCi (KM02, KM13)	02.2004 → 03.2006	K9K 728	D	18	2.0	09.2003 →	F4R 771	B	65
1.5 dCi (KM02, KM13)	02.2004 → 03.2006	K9K 729	D	18	2.0	04.2006 → 11.2010	F4R 770	B	65
1.5 dCi (KM0F, KM0T, KM2B)	08.2003 → 05.2006	K9K 722	D	18	2.0	06.2006 → 12.2010	F4R 771	B	65
1.5 dCi (KM16)	01.2007 → 07.2009	K9K 734	D	19	2.0 dCi	09.2005 →	M9R 700	D	73
1.5 dCi (KM16, KM1E)	05.2005 → 06.2008	K9K 732	D	19	2.0 dCi	09.2005 →	M9R 722	D	73
1.5 dCi (KM1F)	05.2005 → 07.2009	K9K 724	D	19	<b>MEGANE III Coupe (DZ0/1_)</b>				
1.6	08.2003 → 07.2009	K4M 760	B	34	1.2 TCe (DZ16, DZ28)	01.2013 → 08.2015	H5F 404	B	10
1.6	08.2003 → 07.2009	K4M 761	B	34	1.2 TCe (DZ16, DZ28)	01.2013 → 08.2015	H5F 412	B	10
1.6 16V	05.2005 → 07.2009	K4M 762	B	34	1.2 TCe (DZ2B, DZ11)	03.2012 → 08.2015	H5F 400	B	10
1.6 16V	05.2005 → 07.2009	K4M 768	B	34	1.2 TCe (DZ2B, DZ11)	03.2012 → 08.2015	H5F 408	B	10
1.6 16V	01.2006 → 08.2009	K4M 760	B	34	1.5 dCi	07.2014 →	K9K 846	D	25
1.6 16V	01.2006 → 08.2009	K4M 761	B	34	1.5 dCi (DZ09, DZ0D, DZ1F, DZ1G)	02.2009 → 08.2015	K9K 636	D	21
1.6 16V	01.2006 → 08.2009	K4M 812	B	36	1.5 dCi (DZ09, DZ0D, DZ1F, DZ1G)	02.2009 → 08.2015	K9K 836	D	21
1.6 16V	01.2006 → 08.2009	K4M 813	B	36	1.5 dCi (DZ09, DZ0D, DZ1F, DZ1G)	02.2009 → 08.2015	K9K 837	D	21
1.6 16V	05.2006 → 10.2011	K4M 762	B	34	1.5 dCi (DZ09, DZ0D, DZ1F, DZ1G)	02.2009 → 08.2015	K9K 846	D	25
1.6 16V Hi-Flex	02.2008 → 07.2009	K4M 856	B	35	1.5 dCi (DZ0A)	11.2008 → 08.2015	K9K 830	D	25
1.6 LPG 16V	01.2006 → 08.2009	K4M 760	B	34	1.5 dCi (DZ0B)	02.2009 →	K9K 832	D	21
1.9 dCi	03.2004 → 02.2007	F9Q 808	D	49	1.5 dCi (DZ0C, DZ1A)	11.2008 → 08.2015	K9K 834	D	21
1.9 dCi	04.2004 → 12.2005	F9Q 808	D	49	1.6 16V (DZ0H)	11.2008 →	K4M 848	B	35
1.9 dCi	05.2005 → 07.2009	F9Q 803	D	49	1.6 16V (DZ0U, DZ1B, DZ1H)	11.2008 → 08.2015	K4M 858	B	35
1.9 dCi	05.2005 → 07.2009	F9Q 804	D	51	1.6 16V Bifuel (DZ03, DZ1Y)	11.2008 →	K4M 866	B	35
1.9 dCi	05.2005 → 07.2009	F9Q 804	D	51	1.6 dCi (DZ00)	04.2011 → 08.2015	R9M 402	D	52
1.9 dCi	05.2005 → 07.2009	F9Q 818	D	49	2.0 R.S.	11.2008 →	F4R 874	B	68
1.9 dCi	05.2005 → 07.2009	F9Q 818	D	49	2.0 R.S.	07.2014 →	F4R 874	B	68
1.9 dCi (KMRG, KM1G, KMOG, KM2C)	08.2003 → 07.2009	F9Q 800	D	51	2.0 TCe	06.2012 →	F4R 872	B	68
2.0	08.2003 → 07.2009	F4R 770	B	65	2.0 TCe (DZ0K)	11.2008 → 08.2015	F4R 870	B	68
2.0	08.2003 → 07.2009	F4R 771	B	65	2.0 TCe (DZ1N)	05.2009 →	F4R 874	B	68
2.0	12.2006 → 01.2011	F4R 770	B	65					
2.0	12.2006 → 01.2011	F4R 771	B	65					
2.0 dCi	09.2005 → 07.2009	M9R 700	D	73					
2.0 dCi	09.2005 → 07.2009	M9R 722	D	73					

R

			Pos				Pos
2.0 TCe 220	11.2013 →	F4R 874	B	68	1.6 16V (BZ1B, BZ1H)	11.2008 →	K4M 858 B 35
2.0 dCi	07.2012 →	M9R 610	D	73	1.6 16V BiFuel (BZ1U, BZ0U)	05.2009 → 08.2015	K4M 858 B 35
2.0 dCi (DZ0L)	04.2009 → 08.2015	M9R 610	D	73	1.6 16V Hi-Flex (BZ03)	11.2008 → 08.2015	K4M 858 B 35
2.0 dCi (DZ0Y)	04.2009 →	M9R 615	D	73	1.6 16V Hi-Flex (BZ03)	11.2008 → 08.2015	K4M 866 B 35
<b>MEGANE III Grandtour (KZ0/1)</b>							
1.2 TCe (KZ16, KZ28)	01.2013 →	H5F 404	B	10	1.6 dCi (BZ00, BZ12)	04.2011 → 08.2015	R9M 402 D 52
1.2 TCe (KZ16, KZ28)	01.2013 →	H5F 412	B	10	1.6 dCi (BZ00, BZ12)	04.2011 → 08.2015	R9M 404 D 52
1.2 TCe (KZ2B, KZ11)	03.2012 →	H5F 400	B	10	2.0 R.S.	06.2014 →	F4R 874 B 68
1.2 TCe (KZ2B, KZ11)	03.2012 →	H5F 408	B	10	2.0 TCe	06.2012 →	F4R 872 B 68
1.5 dCi	03.2009 →	K9K 830	D	25	2.0 TCe (BZ0K)	11.2008 → 08.2015	F4R 870 B 68
1.5 dCi	11.2013 →	K9K 846	D	25	2.0 TCe 220	11.2013 →	F4R 874 B 68
1.5 dCi (KZ09, KZ0D, KZ1G)	02.2009 →	K9K 636	D	21	2.0 dCi	07.2012 →	M9R 610 D 73
1.5 dCi (KZ09, KZ0D, KZ1G)	02.2009 →	K9K 836	D	21	2.0 dCi (BZ0L)	04.2009 → 08.2015	M9R 610 D 73
1.5 dCi (KZ09, KZ0D, KZ1G)	02.2009 →	K9K 837	D	21	2.0 dCi (BZ0Y)	10.2010 →	M9R 615 D 73
1.5 dCi (KZ09, KZ0D, KZ1G)	02.2009 →	K9K 846	D	25	<b>MEGANE IV GRAND COUPE</b>		
1.5 dCi (KZ0C, KZ1A)	05.2009 →	K9K 834	D	21	1.2 Tce 130	10.2016 →	H5F 408 B 10
1.5 dCi (KZ1M, KZ1W)	02.2009 →	K9K 832	D	21	1.5 Blue dCi 115 (LVA6)	02.2019 →	K9K 872 D 25
1.5 dCi (KZ1M, KZ1W)	02.2009 →	K9K 836	D	21	1.5 Blue dCi 115 (LVA6)	02.2019 →	K9K 873 D 21
1.5 dCi (KZ1M, KZ1W)	02.2009 →	K9K 846	D	25	1.5 Blue dCi 95 (LVA2)	02.2019 →	K9K 872 D 25
1.6 16V (KZ0H)	05.2009 →	K4M 848	B	35	1.5 dCi 110	10.2016 →	K9K 656 D 25
1.6 16V (KZ0U, KZ1B, KZ1U)	05.2009 →	K4M 858	B	35	1.5 dCi 110	10.2016 →	K9K 657 D 21
1.6 16V (KZ0U, KZ1B, KZ1U)	05.2009 →	K4M 866	B	35	1.5 dCi 110	10.2016 →	K9K 675 D 28
1.6 BiFuel (KZ03)	11.2008 →	K4M 866	B	35	1.5 dCi 90 (LVA1)	10.2016 →	K9K 656 D 25
1.6 dCi (KZ00, KZ12, KZ13)	04.2011 →	R9M 402	D	52	1.6 dCi 130	10.2016 →	R9M 409 D 53
1.6 dCi (KZ00, KZ12, KZ13)	04.2011 →	R9M 404	D	52	<b>MEGANE IV Grandtour (K9A/M/N_)</b>		
1.6 dCi (KZ00, KZ12, KZ13)	04.2011 →	R9M 414	D	53	1.2 TCe 100	04.2016 →	H5F 408 B 10
2.0 TCe	09.2012 →	F4R 872	B	68	1.2 TCe 130 (K9MR)	04.2016 →	H5F 408 B 10
2.0 TCe	09.2012 →	F4R 874	B	68	1.5 Blue dCi 115 (K9A6)	08.2018 →	K9K 872 D 25
2.0 TCe (KZ0K, KZ1T)	11.2008 →	F4R 870	B	68	1.5 Blue dCi 115 (K9A6)	08.2018 →	K9K 873 D 21
2.0 TCe (KZ0K, KZ1T)	11.2008 →	F4R 872	B	68	1.5 Blue dCi 95 (K9A2)	08.2018 →	K9K 872 D 25
2.0 dCi	07.2012 →	M9R 610	D	73	1.5 dCi 110	04.2016 →	K9K 656 D 25
2.0 dCi (KZ0L)	04.2009 →	M9R 610	D	73	1.5 dCi 110	04.2016 →	K9K 657 D 21
2.0 dCi (KZ0Y)	10.2010 →	M9R 615	D	73	1.5 dCi 90	04.2016 →	K9K 656 D 25
<b>MEGANE III Hatchback (BZ0/1_ , B3_)</b>							
1.2 TCe (BZ16, BZ28)	01.2013 →	H5F 404	B	10	1.6 dCi 130	04.2016 →	R9M 409 D 53
1.2 TCe (BZ16, BZ28)	01.2013 →	H5F 412	B	10	1.6 dCi 165	04.2016 →	R9M 452 D 53
1.2 TCe (BZ2B, BZ11)	03.2012 → 08.2015	H5F 400	B	10	<b>MEGANE IV Hatchback (B9A/M/N_)</b>		
1.2 TCe (BZ2B, BZ11)	03.2012 → 08.2015	H5F 408	B	10	1.2 TCe 100 (B9MS)	11.2015 →	H5F 408 B 10
1.5 DCi (BZ29)	02.2009 → 08.2015	K9K 656	D	25	1.2 TCe 130 (B9MR)	11.2015 →	H5F 408 B 10
1.5 dCi	11.2008 →	K9K 830	D	25	1.5 Blue dCi 115 (B9A6)	08.2018 →	K9K 872 D 25
1.5 dCi	02.2009 →	K9K 832	D	21	1.5 Blue dCi 115 (B9A6)	08.2018 →	K9K 873 D 21
1.5 dCi (BZ09, BZ0D, BZ1W, BZ29)	02.2009 →	K9K 636	D	21	1.5 Blue dCi 95 (B9A2)	08.2018 →	K9K 872 D 25
1.5 dCi (BZ09, BZ0D, BZ1W, BZ29)	02.2009 →	K9K 656	D	25	1.5 dCi 110 (B9A3)	11.2015 →	K9K 646 D 21
1.5 dCi (BZ09, BZ0D, BZ1W, BZ29)	02.2009 →	K9K 657	D	21	1.5 dCi 110 (B9A3)	11.2015 →	K9K 656 D 25
1.5 dCi (BZ09, BZ0D, BZ1W, BZ29)	02.2009 →	K9K 836	D	21	1.5 dCi 110 (B9A3)	11.2015 →	K9K 657 D 21
1.5 dCi (BZ09, BZ0D, BZ1W, BZ29)	02.2009 →	K9K 837	D	21	1.5 dCi 90 (B9A1)	11.2015 →	K9K 656 D 25
1.5 dCi (BZ09, BZ0D, BZ1W, BZ29)	02.2009 →	K9K 846	D	25	1.6 dCi 130 (B9A4)	11.2015 →	R9M 409 D 53
1.5 dCi (BZ0C)	11.2008 → 08.2015	K9K 834	D	21	1.6 dCi 165	11.2015 →	R9M 452 D 53
1.5 dCi (BZ1G, BZ1W, BZ0R)	11.2013 → 08.2015	K9K 846	D	25	<b>MEGANE Scenic (JA0/1_)</b>		
1.6 16V	11.2008 →	K4M 858	B	35	1.4 i (JA0E)	01.1997 → 09.1999	E7J 764 B 16
1.6 16V	11.2008 →	K4M 866	B	35	1.6 16V (JA0B, JA04, JA11)	04.1998 → 10.1999	K4M 700 B 33
1.6 16V	01.2013 →	K4M 848	B	35	1.6 16V (JA0B, JA04, JA11)	04.1998 → 10.1999	K4M 701 B 33
1.6 16V	01.2013 →	K4M 858	B	35	1.6 16V (JA0B, JA04, JA11)	04.1998 → 10.1999	K4M 704 B 33
1.6 16V (BZ0H)	11.2008 → 08.2015	K4M 848	B	35	1.6 16V (JA0B, JA04, JA11)	04.1998 → 10.1999	K4M 708 B 33
1.6 16V (BZ0H, BZ1R)	01.2010 → 08.2015	K4M 848	B	35	1.6 e (JA0F)	01.1997 → 10.1999	K7M 702 B 32
					1.6 e (JA0F)	01.1997 → 10.1999	K7M 703 B 32
					1.6 i (JA0L)	01.1997 → 09.1999	K7M 720 B 32
					1.9 D (JA0J)	03.1997 → 09.1999	F8Q 790 D 45
					1.9 dT (JA0K, JA0Y)	01.1997 → 09.1999	F8Q 784 D 41
					1.9 dT (JA0K, JA0Y)	01.1997 → 09.1999	F8Q 786 D 44
					1.9 dT (JA0Y)	03.1997 → 08.1999	F8Q 784 D 41
					1.9 dTi (JA0N)	04.1997 → 09.1999	F9Q 730 D 46
					1.9 dTi (JA0N)	04.1997 → 09.1999	F9Q 734 D 46
					2.0	01.1999 → 12.2001	F3R 798 B 61
					2.0 RXE 4x4	05.1997 → 10.1999	F3R 750 B 60
					2.0 i (JA02, JA0G)	01.1999 → 09.1999	F3R 791 B 60
					2.0 i (JA02, JA0G)	01.1999 → 09.1999	F3R 796 B 61

					Pos					
2.0 i (JA0G)	01.1997 → 09.1999	F3R 750	B	60	1.6	11.2007 →	K4M 732	B	33	
2.0 i (JA0G)	01.1997 → 09.1999	F3R 751	B	60	1.6	11.2007 →	K7M 710	B	32	
<b>MODUS / GRAND MODUS</b>					1.6	12.2007 → 07.2013	K4M 697	AB	38	
1.2i 16V	09.2007 →	D4F 780	B	5	1.6	12.2007 →	K4M 710	B	32	
<b>MODUS / GRAND MODUS (F/JP0_)</b>					1.6	02.2008 →	K4M 706	B	33	
1.2	04.2011 →	D4F 786	B	5	1.6	02.2009 →	K7M 710	B	32	
1.2 (FP0C, FP0K, FP0P)	05.2005 →	D4F 740	BG	3	1.6	05.2009 →	K7M 710	B	32	
1.2 (JP0C, JP0K, FP0C, FP0K, FP0P, JP0P, JP0T)	12.2004 →	D4F 740	BG	3	1.6	09.2009 →	K4M 732	B	33	
1.2 (JP0S)	12.2004 →	D4F 764	B	5	1.6	11.2010 →	K7M 718	B	32	
1.2 16V (JP0W)	05.2007 →	D4F 784	B	5	1.6	12.2012 →	K4M 690	B	33	
1.2 16V Hi-Flex	10.2008 →	D4F 740	BG	3	1.6 Flex	12.2012 →	K4M 696	B	35	
1.2 GPL (JP0R)	05.2008 → 12.2012	D4F 744	BG	3	1.6 Flex (BS0V, BS1V, BS09)	08.2008 →	K4M 766	B	35	
1.4 (JP01, JP0J)	12.2004 →	K4J 770	B	33	<b>SANDERO/STEPWAY II (B8_)</b>					
1.4 (JP01, JP0J)	12.2004 →	K4J 780	B	33	1.2 16V	12.2013 →	D4F 732	B	5	
1.5 dCi (FP0D, JP0D)	09.2004 →	K9K 750	D	18	1.2 16V	12.2013 →	D4F 734	B	5	
1.5 dCi (FP0E, JP0E)	12.2004 →	K9K 752	D	22	1.2 16V	04.2015 →	D4F 732	B	5	
1.5 dCi (FP0E, JP0E)	12.2004 →	K9K 768	D	19	1.2 16V LPG	12.2013 →	D4F 734	B	5	
1.5 dCi (FP0F, JP0F)	12.2004 →	K9K 760	D	21	1.5 dCi	12.2013 →	K9K 830	D	25	
1.5 dCi (FP0F, JP0F)	12.2004 →	K9K 766	D	22	1.6	09.2014 →	K4M 842	B	35	
1.5 dCi (FP0G, JP0G)	12.2004 →	K9K 768	D	19	1.6	05.2015 →	K7M 710	B	32	
1.5 dCi (JP02)	05.2007 →	K9K 772	D	21	1.6 16V	04.2014 →	K4M 732	B	33	
1.5 dCi (JP0G, JP0H)	05.2005 →	K9K 764	D	19	1.6 16V	04.2014 →	K4M 766	B	35	
1.5 dCi 75	10.2010 →	K9K 770	D	21	1.6 16V	04.2014 →	K4M 845	B	35	
1.5 dCi 90	10.2010 →	K9K 750	D	18	1.6 16V	05.2015 →	K4M 842	B	35	
1.5 dCi 90	10.2010 →	K9K 770	D	21	2.0 RS	04.2016 →	F4R 412	AB	71	
1.6 (JP03, JP0B, JP0U, JP0Y, JP1G)	12.2004 →	K4M 790	B	34	2.0 RS	04.2016 →	F4R 416	AB	71	
1.6 (JP03, JP0B, JP0U, JP0Y, JP1G)	12.2004 →	K4M 791	B	34	2.0 RS	09.2019 →	F4R 412	AB	71	
1.6 (JP03, JP0B, JP0U, JP0Y, JP1G)	12.2004 →	K4M 800	B	36	2.0 RS	09.2019 →	F4R 416	AB	71	
1.6 (JP03, JP0B, JP0U, JP0Y, JP1G)	12.2004 →	K4M 801	B	36	2.0 RS Flex (B8A4)	09.2015 →	F4R 412	AB	71	
1.6 (JP0L, JP0V)	12.2004 →	K4M 794	B	34	2.0 RS Flex (B8A4)	09.2015 →	F4R 416	AB	71	
<b>OROCH</b>					TCe 90	09.2015 →	H4B 400	B	11	
1.6 16V	09.2015 →	K4M 690	B	33	<b>SCALA (LJM_)</b>					
1.6 16V	09.2015 →	K4M 690	B	33	1.5 dCi	09.2012 → 10.2017	K9K 766	D	22	
1.6 Flex	09.2015 → 09.2017	K4M 842	B	35	<b>SCÉNIC I Großraumlimousine (JA0/1_, FA0_)</b>					
<b>RAPID</b>					1.9 TD	11.1996 → 03.1997	F8Q 784	D	41	
1.9 D	09.1994 → 03.1998	F8Q 646	D	42	1.9 TD	11.1996 → 03.1997	F8Q 786	D	44	
1.9 D	09.1994 → 03.1998	F8Q 684	D	42	<b>SCÉNIC I MPV (JA0/1_, FA0_)</b>					
1.9 D	09.1994 → 03.1998	F8Q 724	D	42	1.4 16V (JA0D, JA1H, Ja0W, JA10)	09.1999 → 08.2003	K4J 714	B	33	
1.9 D	09.1994 → 03.1998	F8Q 776	D	42	1.4 16V (JA0D, JA1H, Ja0W, JA10)	09.1999 → 08.2003	K4J 750	B	33	
<b>RODEO</b>					1.6	03.2001 → 08.2003	K4M 708	B	33	
6 1.3	10.1980 → 08.1981	810.10	B	13	1.6	03.2001 → 08.2003	K4M 709	B	33	
6 1.3	10.1980 → 08.1981	810.19	B	13	1.6	06.2001 → 09.2003	K4M 700	B	33	
<b>RODEO 6 (ACL_)</b>					1.6	06.2001 → 09.2003	K4M 701	B	33	
1.1	08.1973 → 11.1981	688.10	B	7	1.6	06.2001 → 09.2003	K4M 708	B	33	
<b>SAFRANE I (B54_)</b>					1.6 (JA00, JA16, JA15, JA19, JA1V, JA2B, JA2C, JA0B)	09.1999 → 09.2003	K4M 700	B	33	
2.0 (B540)	11.1992 → 07.1996	J7R 732	B	95	1.6 (JA00, JA16, JA15, JA19, JA1V, JA2B, JA2C, JA0B)	09.1999 → 09.2003	K4M 706	B	33	
2.0 (B540)	11.1992 → 07.1996	J7R 733	B	95	1.6 (JA00, JA16, JA15, JA19, JA1V, JA2B, JA2C, JA0B)	09.1999 → 09.2003	K4M 707	B	35	
2.1 dT (B546)	11.1993 → 07.1996	J8S 760	D	89	1.6 (JA00, JA16, JA15, JA19, JA1V, JA2B, JA2C, JA0B)	09.1999 → 09.2003	K4M 776	B	33	
2.2 (B541)	04.1992 → 07.1996	J7T 762	B	95	1.6 (JA00, JA16, JA15, JA19, JA1V, JA2B, JA2C, JA0B)	09.1999 → 09.2003	K4M 712	B	33	
2.2 (B543)	02.1994 → 07.1996	J7T 760	B	95	1.6 BiFuel	03.2001 → 08.2003	K4M 712	B	33	
2.5 dT (B548)	12.1992 → 07.1996	S8U 762	D	99	1.6 BiFuel (JA04)	09.1999 → 04.2001	K4M 704	B	33	
2.5 dT (B548)	12.1992 → 07.1996	S8U 763	D	104	1.6 BiFuel (JA04)	09.1999 → 04.2001	K4M 712	B	33	
<b>SAFRANE II (B54_)</b>					1.6 Hi-Flex (JA0B)	03.2005 → 07.2010	K4M 700	B	33	
2.0 16V (B54L)	07.1996 → 12.2000	N7Q 710	B	72	1.6 Hi-Flex (JA0B)	03.2005 → 07.2010	K4M 701	B	33	
2.0 16V (B54L)	07.1996 → 12.2000	N7Q 711	B	72	1.6 Hi-Flex (JA0B)	03.2005 → 07.2010	K4M 708	B	33	
2.2 dT (B54G)	07.1996 → 12.2000	G8T 740	D	92	1.8 16V (JA12, JA1R, JA1M, JA1A)	01.2001 → 08.2003	F4P 720	B	65	
<b>SANDERO/STEPWAY I (BS_)</b>					1.8 16V (JA12, JA1R, JA1M, JA1A)	01.2001 → 08.2003	F4P 722	B	65	
1.0 Authentique Hi-Flex	06.2014 → 12.2016	D4D 754	B	5	1.8 4x4	07.2000 → 04.2001	F4P 722	B	65	
1.0 Hi-Flex	11.2007 →	D4D 754	B	5						
1.0 Hi-Flex (BS0R, BS1R, BS1G)	11.2007 →	D4D 754	B	5						
1.4	02.2009 →	K7J 710	B	32						
1.5 dCi	02.2008 → 11.2011	K9K 700	D	18						
1.5 dCi	02.2008 → 11.2011	K9K 740	D	21						
1.5 dCi	02.2008 → 11.2011	K9K 790	D	26						

R

		Pos			Pos
1.9 D (JA0J, FA0J) 09.1999 → 03.2001	F8Q 788	D 40	1.5 dCi 02.2009 →	K9K 832	D 21
1.9 D (JA0J, FA0J) 09.1999 → 03.2001	F8Q 790	D 45	1.5 dCi 04.2009 →	K9K 636	D 21
1.9 dCi (JA05, JA1F) 09.1999 → 08.2003	F9Q 732	D 50	1.5 dCi 04.2009 →	K9K 656	D 25
1.9 dCi (JA05, JA1F) 09.1999 → 08.2003	F9Q 733	D 50	1.5 dCi 04.2009 →	K9K 657	D 21
1.9 dCi RX4 11.2000 → 08.2003	F9Q 740	D 50	1.5 dCi 04.2009 →	K9K 830	D 25
1.9 dCi RX4 12.2002 → 08.2003	F9Q 732	D 50	1.5 dCi 04.2009 →	K9K 836	D 21
1.9 dCi RX4 12.2002 → 08.2003	F9Q 748	D 49	1.5 dCi 04.2009 →	K9K 837	D 21
1.9 dTi (JA0N) 09.1999 → 08.2003	F9Q 731	D 46	1.5 dCi (JZ02, JZ0R) 11.2010 →	K9K 846	D 25
1.9 dTi (JA0N) 09.1999 → 08.2003	F9Q 734	D 46	1.6 16V (JZ0U, JZ1B) 02.2009 →	K4M 858	B 35
1.9 dTi (JA0N) 09.1999 → 08.2003	F9Q 736	D 46	1.6 16V Bifuel 02.2009 →	K4M 866	B 35
1.9 dTi (JA1U) 02.2001 → 08.2003	F9Q 744	D 51	1.6 16V Bifuel 04.2012 → 12.2013	K4M 866	B 35
2.0 16V 09.1999 → 08.2003	F4R 740	B 65	1.6 E85 (JZ03, JZ1Y) 02.2009 →	K4M 866	B 35
2.0 16V 09.1999 → 08.2003	F4R 741	B 65	1.6 dCi (JZ00, JZ12) 04.2011 →	R9M 402	D 52
2.0 16V 09.1999 → 08.2003	F4R 744	B 65	1.6 dCi (JZ00, JZ12) 04.2011 →	R9M 404	D 52
2.0 16V 09.1999 → 08.2003	F4R 747	B 65	1.6 dCi (JZ00, JZ12) 04.2011 →	R9M 414	D 53
2.0 16V (JA1B, JA1D) 07.2000 → 08.2003	F4R 740	B 65	2.0 dCi (JZ0L) 04.2009 →	M9R 610	D 73
2.0 16V (JA1B, JA1D) 07.2000 → 08.2003	F4R 741	B 65	2.0 dCi (JZ0Y, JZ26) 02.2009 →	M9R 615	D 73
2.0 16V (JA1B, JA1D) 07.2000 → 08.2003	F4R 746	B 65	<b>SCÉNIC IV (J9 )</b>		
2.0 16V RX4 06.2000 → 08.2003	F4R 744	B 65	1.2 TCe 115 09.2016 →	H5F 408	B 10
2.0 16V RX4 06.2000 → 08.2003	F4R 746	B 65	1.2 TCe 130 09.2016 →	H5F 408	B 10
<b>SCÉNIC II (JM0/1 )</b>			1.5 dCi 110 09.2016 →	K9K 646	D 21
1.4 (JM0B, JM0H, JM1A) 06.2003 → 11.2008	K4J 730	B 33	1.5 dCi 110 09.2016 →	K9K 647	D 21
1.4 (JM0B, JM0H, JM1A) 06.2003 → 11.2008	K4J 740	B 33	1.5 dCi 110 Hybrid 04.2017 →	K9K 500	D 21
1.4 (JM0B, JM0H, JM1A) 06.2003 → 11.2008	K4J 770	B 33	Assist (J9AE)		
1.5 dCi (JM02, JM13) 11.2003 → 08.2005	K9K 728	D 18	1.5 dCi 95 09.2016 →	K9K 646	D 21
1.5 dCi (JM02, JM13) 11.2003 → 08.2005	K9K 729	D 18	1.5 dCi 95 09.2016 →	K9K 846	D 25
1.5 dCi (JM0F) 06.2003 → 05.2006	K9K 722	D 18	1.6 dCi 130 09.2016 →	R9M 409	D 53
1.5 dCi (JM16) 01.2007 → 11.2008	K9K 728	D 18	1.6 dCi 160 09.2016 →	R9M 452	D 53
1.5 dCi (JM16) 01.2007 → 11.2008	K9K 734	D 19	<b>SPORT SPIDER (EF0 )</b>		
1.5 dCi (JM1E, JM16) 05.2005 → 11.2008	K9K 732	D 19	2.0 12.1995 → 08.1996	F7R 710	B 62
1.5 dCi (JM1E, JM16) 05.2005 → 11.2008	K9K 734	D 19	2.0 16V 03.1995 → 10.1999	F7R 710	B 62
1.5 dCi (JM1F) 05.2005 → 11.2008	K9K 724	D 19	<b>SUPER 5 (B/C40 )</b>		
1.6 06.2006 → 11.2008	K4M 788	B 34	1.1 10.1989 → 06.1990	C1E 750	B 7
1.6 (JM0C, JM0J, JM1B) 06.2003 → 10.2006	K4M 761	B 34	1.1 (B/C/401) 10.1984 → 10.1988	C1E 750	B 7
1.6 (JM0C, JM0J, JM1B) 06.2003 → 10.2006	K4M 782	B 34	1.1 (B/C/401) 10.1984 → 10.1988	C1E 752	B 7
1.6 16V (JM1R) 10.2005 → 11.2008	K4M 706	B 33	1.1 (B/C/401) 10.1984 → 10.1988	C1E 754	B 7
1.6 16V (JM1R) 10.2005 → 11.2008	K4M 766	B 35	1.1 (B/C/401, B/C40H) 01.1986 → 06.1989	C1E 752	B 7
1.6 16V (JM1R) 10.2005 → 11.2008	K4M 812	B 36	1.1 (B/C/401, B/C40H) 01.1986 → 07.1989	C1E 750	B 7
1.6 16V (JM1R) 10.2005 → 11.2008	K4M 813	B 36	1.1 (B/C/401, B/C40H) 01.1986 → 07.1989	C1E 756	B 7
1.6 BiFuel 08.2003 → 05.2006	K4M 764	B 33	1.1 (B/C/401, B/C40H) 01.1986 → 08.1991	C1E 760	B 7
1.6 Hi-Flex 03.2005 → 07.2010	K4M 766	B 35	1.2 (B/C40F) 01.1987 → 08.1990	C1G 702	B 8
1.9 D 06.2006 → 11.2008	F9Q 812	D 49	1.2 (B/C40F) 01.1987 → 08.1990	C1G 720	B 8
1.9 D 06.2006 → 11.2008	F9Q J 803	D 49	1.2 (B/C40F) 01.1987 → 08.1990	C1G 722	B 8
1.9 dCi 06.2003 → 11.2008	F9Q 804	D 51	1.4 (B/C402) 10.1984 → 06.1988	C1J 768	B 17
1.9 dCi 04.2004 → 10.2008	F9Q 803	D 49	1.4 (B/C402) 10.1984 → 06.1988	C1J 780	B 17
1.9 dCi (JM0G, JM12, JM1G, JM2C) 06.2003 → 05.2006	F9Q 812	D 49	1.4 (B/C403) 10.1984 → 07.1989	C2J 780	B 17
1.9 dCi (JM14) 05.2005 → 11.2008	F9Q 804	D 51	1.4 (B/C403) 10.1984 → 07.1989	C2J 781	B 17
1.9 dCi (JM14) 05.2005 → 11.2008	F9Q 816	D 49	1.4 (B/C403) 10.1984 → 07.1989	C2J 788	B 17
1.9 dCi (JM14) 05.2005 → 11.2008	F9Q 818	D 49	1.4 (B/C403) 10.1984 → 07.1989	C2J 789	B 17
1.9 dCi (JM14) 05.2005 → 11.2008	F9Q J 803	D 49	1.4 (B/C403) 06.1986 → 06.1989	C2J 798	B 17
1.9 dCi (JM15) 05.2005 → 11.2008	F9Q 804	D 51	1.4 (B/C403) 06.1987 → 07.1989	C2J 700	B 17
1.9 dCi 130 10.2005 → 12.2009	F9Q 804	D 51	1.4 (B/C40J) 07.1987 → 07.1989	C2J 782	B 17
2.0 02.2008 → 04.2009	F4R 771	B 65	1.4 (B/C40M) 06.1987 → 08.1990	C2J 784	B 17
2.0 (JM05, JM0U, JM1N, JM1U, JM2V) 06.2003 → 06.2009	F4R 770	B 65	1.4 Cat (B/C/407) 10.1985 → 08.1991	C3J 760	B 15
2.0 (JM05, JM0U, JM1N, JM1U, JM2V) 06.2003 → 06.2009	F4R 771	B 65	1.4 Cat (B/C/407) 10.1985 → 12.1996	C3J 700	B 17
2.0 16V Turbo (JM0W) 05.2004 → 11.2008	F4R 776	B 65	1.4 Cat (B/C/407) 08.1988 → 12.1996	C3J 702	B 17
2.0 dCi (JM1K) 09.2005 → 11.2008	M9R 700	D 73	1.4 Turbo (C405) 07.1986 → 08.1990	C1J 784	B 17
2.0 dCi (JM1K) 09.2005 → 11.2008	M9R 721	D 73	1.4 Turbo (C405) 10.1986 → 08.1990	C1J 782	B 17
2.0 dCi (JM1K) 09.2005 → 11.2008	M9R 722	D 73	1.4 Turbo (C405) 06.1987 → 08.1990	C1J 788	B 17
<b>SCÉNIC III (JZ0/1 )</b>			1.6 D 04.1985 → 12.1990	F8M 730	D 30
1.2 TCe 04.2012 →	H5F 400	B 10	1.6 D (B/C/404) 08.1985 → 09.1987	F8M 720	D 30
1.2 TCe 07.2014 →	H5F 408	B 10	1.6 D (B/C/404) 10.1987 → 07.1989	F8M 730	D 30
1.2 TCe (JZ16) 01.2013 →	H5F 404	B 10	1.7 09.1988 → 09.1990	F2N 740	B 56
1.2 TCe (JZ16) 01.2013 →	H5F 408	B 10	1.7 (B/C408) 10.1986 → 03.1995	F3N 716	B 56
			1.7 (B/C408) 10.1986 → 03.1995	F3N 717	B 56
			1.7 (B/C40K, B/C40G) 06.1987 → 03.1995	F2N 740	B 56
			1.7 (B/C40K, B/C40G) 06.1987 → 03.1995	F2N 742	B 56
			1.7 i (C409) 10.1986 → 08.1991	F3N 702	B 56
			1.7 i (C409) 10.1986 → 08.1991	F3N 722	B 56



					Pos						Pos		
<b>SYMBOL</b>					0.9 TCe	06.2014 → 06.2014	H4B 400	B	11				
1.2i 16V		D4F 728	B	5	1.2 16V	12.2013 →	D4F 732	B	5				
1.4i	05.2001 →	K7J 700	B	16	1.2 LPG	03.2014 →	D4F 732	B	5				
1.4i 16V	06.2001 →	K4J 712	B	33	1.5 dCi	12.2013 →	K9K 612	D	21				
1.4i 16V	06.2001 →	K4J 713	B	33	1.5 dCi	12.2013 →	K9K 830	D	25				
1.5 dCi		K9K 700	D	18	1.5 dCi	12.2013 →	K9K 838	D	21				
1.5 dCi		K9K 706	D	19	1.5 dCi	07.2014 → 06.2014	K9K 612	D	21				
1.5 dCi		K9K 718	D	20	1.5 dCi	11.2019 →	K9K 872	D	25				
1.5 dCi		K9K 740	D	21	1.5 dCi (L8AJ)	12.2013 →	K9K 612	D	21				
1.6i	11.2001 →	K4M 734	B	34	1.6 16V	12.2013 → 09.2014	K4M 842	B	35				
1.6i 16V		K4M 670	B	35	1.6 16V	12.2013 →	K4M 842	B	35				
1.6i 16V		K4M 674	B	35	<b>TWINGO I (C06_)</b>								
1.6i 16V		K4M 745	B	33	1.0	03.2001 → 05.2007	D4D 712	B	5				
<b>TALISMAN (LP_)</b>					1.0i 16V	03.2001 →	D4D 712	B	5				
1.5 dCi 110	11.2015 →	K9K 646	D	21	1.2	09.1998 → 08.2000	D7F 702	B	4				
1.5 dCi 110	11.2015 →	K9K 647	D	21	1.2	09.1998 → 08.2000	D7F 703	B	4				
1.6 dCi 130	11.2015 →	R9M 409	D	53	1.2	09.1998 → 08.2000	D7F 704	B	4				
1.6 dCi 160	06.2015 →	R9M 452	D	53	1.2 (C063, C064)	03.1993 → 10.1996	C3G 700	B	14				
1.6 dCi 160	06.2015 →	R9M 453	D	53	1.2 (C063, C064)	10.1994 → 10.1996	C3G 702	B	14				
<b>TALISMAN Grandtour (KP_)</b>					1.2 (C066, C068)	05.1996 → 06.2007	D7F 700	B	4				
1.5 dCi 110	03.2016 →	K9K 646	D	21	1.2 (C066, C068)	05.1996 → 06.2007	D7F 701	B	4				
1.5 dCi 110	03.2016 →	K9K 647	D	21	1.2 (C066, C068)	05.1996 → 06.2007	D7F 702	B	4				
1.6 dCi 130	03.2016 →	R9M 409	D	53	1.2 (C066, C068)	05.1996 → 06.2007	D7F 703	B	4				
1.6 dCi 160	03.2016 →	R9M 452	D	53	1.2 (C066, C068)	05.1996 → 06.2007	D7F 704	B	4				
1.6 dCi 160	03.2016 →	R9M 453	D	53	1.2 (C067)	05.1996 → 03.2007	D7F 700	B	4				
<b>THALIA I (LB_)</b>					1.2 (C067)	05.1996 → 03.2007	D7F 701	B	4				
1.0	06.2000 → 01.2005	D4D 754	B	5	1.2 16V (C060)	08.2004 → 06.2007	D4F 708	B	5				
1.0 Expression Hi-Flex	11.2005 → 02.2009	D4D 754	B	5	1.2 16V (C06C, C06D, C06K)	01.2001 → 06.2007	D4F 702	B	5				
1.2	02.1998 → 10.2003	D7F 744	B	4	1.2 LPG	10.2003 → 06.2007	D7F 702	B	4				
1.2	02.1998 → 10.2003	D7F 746	B	4	1.2 LPG	10.2003 → 06.2007	D7F 708	B	4				
1.2 16V	04.2002 →	D4F 706	B	5	<b>TWINGO II (CN0_)</b>								
1.2 16V	04.2002 →	D4F 712	B	5	1.2 (CN0D)	03.2007 → 09.2014	D7F 800	B	4				
1.2 16V	04.2002 →	D4F 728	B	5	1.2 16V	03.2008 →	D4F 764	B	5				
1.4	08.2000 →	K7J 700	B	16	1.2 16V (CN04, CN0A, CN0B)	03.2007 → 09.2014	D4F 764	B	5				
1.4 (LB17)	05.2000 → 02.2009	K7J 700	B	16	1.2 16V (CN04, CN0A, CN0B)	03.2007 → 09.2014	D4F 770	B	5				
1.4 16V	08.2000 →	K4J 712	B	33	1.2 16V (CN04, CN0A, CN0B)	03.2007 → 09.2014	D4F 772	B	5				
1.5 dCi	06.2001 → 02.2009	K9K 706	D	19	1.2 16V (CN0K, CN0V)	03.2007 →	D4F 772	B	5				
1.5 dCi	06.2001 → 02.2009	K9K 718	D	20	1.2 TCe 100 (CN0P)	02.2011 →	D4F 780	B	5				
1.5 dCi	04.2002 →	K9K 700	D	18	1.2 TCe 100 (CN0P)	02.2011 →	D4F 782	B	5				
1.5 dCi	02.2003 →	K9K 700	D	18	1.2 Turbo (CN0C, CN0F)	03.2007 → 09.2014	D4F 780	B	5				
1.5 dCi	02.2003 →	K9K 714	D	18	1.2 Turbo (CN0C, CN0F)	03.2007 → 09.2014	D4F 782	B	5				
1.5 dCi	04.2004 → 11.2009	K9K 706	D	19	1.5 dCi (CN0E)	03.2007 → 09.2014	K9K 740	D	21				
1.5 dCi	06.2005 →	K9K 740	D	21	1.5 dCi (CN0U)	04.2008 → 09.2014	K9K 718	D	20				
1.6	03.1998 →	K7M 746	B	32	1.5 dCi 75	10.2010 →	K9K 820	D	21				
1.6	06.1999 → 04.2003	K7M 746	B	32	1.5 dCi 90	10.2010 →	K9K 820	D	21				
1.6	05.2000 → 10.2004	K4M 743	B	33	1.6 RS (CN0N, CN0R, CN0S)	05.2008 → 09.2014	K4M 854	B	34				
1.6	01.2004 → 12.2008	K4M 736	B	34	<b>TWINGO III (BCM_)</b>								
1.6 16V	07.2000 → 02.2009	K4M 740	B	33	0.9 TCe 110	11.2016 →	H4B 401	B	11				
1.6 Authentique Hi-Flex (LB2K)	11.2004 → 02.2009	K4M 742	B	33	0.9 TCe 90	09.2014 →	H4B 401	B	11				
1.6 Authentique Hi-Flex (LB2K)	11.2004 → 02.2009	K4M 743	B	33	0.9 TCe 90 LPG (BCMD)	08.2018 →	H4B 451	BG	9				
1.9 D	02.1998 → 05.2001	F8Q 630	D	47	0.9 TCe 95	03.2019 →	H4B 453	B	12				
<b>THALIA II (LU_)</b>					<b>VEL SATIS (BJ0_)</b>								
1.2 16V (LU2V)	09.2008 → 06.2014	D4F 728	B	5	2.0 16 V Turbo	04.2004 →	F4R 766	B	65				
1.2 LPG	01.2010 → 12.2013	D4F 728	B	5	2.0 16 V Turbo	04.2004 →	F4R 767	B	65				
1.4	09.2008 → 06.2014	K7J 700	B	16	2.0 16V Turbo (BJ0K)	06.2002 → 08.2009	F4R 762	B	65				
1.4	01.2009 → 12.2011	K4J 712	B	33	2.0 16V Turbo (BJ0K)	06.2002 → 08.2009	F4R 763	B	65				
1.5 dCi	09.2008 →	K9K 718	D	20	2.0 Turbo	04.2005 →	F4R 867	B	68				
1.5 dCi	09.2008 →	K9K 740	D	21	2.0 dCi (BJ03)	08.2005 →	M9R 760	D	73				
1.5 dCi	01.2009 →	K9K 700	D	18	2.0 dCi (BJ03, BJ0B)	01.2006 →	M9R 760	D	73				
1.5 dCi	01.2009 →	K9K 834	D	21	2.0 dCi (BJ03, BJ0B)	01.2006 →	M9R 762	D	73				
1.6	01.2009 → 05.2012	K7M 746	B	32	2.0 dCi (BJ03, BJ0B)	01.2006 →	M9R 763	D	73				
1.6 16V	09.2008 →	K4M 743	B	33	2.2 dCi (BJ0E, BJ0F)	06.2002 → 08.2009	G9T 702	D	94				
1.6 16V (LU1A, LU1B, LU1D, LU2M)	01.2009 →	K4M 744	B	33	2.2 dCi (BJ0E, BJ0F)	06.2002 → 08.2009	G9T 703	D	94				
1.6 16V (LU1A, LU1B, LU1D, LU2M)	01.2009 →	K4M 745	B	33	2.2 dCi (BJ0E, BJ0F, BJ0J, BJ0H)	09.2004 →	G9T 600	D	94				
1.6 Flex (LU0C, LU05)	03.2009 → 03.2013	K4M 744	B	33									
<b>THALIA III (L8_)</b>													

R

		Pos			Pos
2.2 dCi (BJ0E, BJ0F, BJ0G, BJ0H) 09.2004 →	G9T 606	D	1.9 D 01.1991 → 12.1993	F8Q 730	D
2.2 dCi (BJ0E, BJ0F, BJ0G, BJ0H) 09.2004 →	G9T 607	D	1.9 D 01.1991 → 09.1998	F8Q 732	D
2.2 dCi (BJ0E, BJ0F, BJ0G, BJ0H) 09.2004 →	G9T 700	D	1.9 RND 04.1996 → 02.1998	F8Q 678	D
2.2 dCi (BJ0E, BJ0F, BJ0G, BJ0H) 09.2004 →	G9T 702	D	<b>CLIO II Hatchback Van (SB0/1/2_)</b>		
2.2 dCi (BJ0H) 04.2004 →	G9T 600	D	1.2 (SB0A, SB0F, SB10) 03.1999 → 10.2003	D7F 722	B
2.2 dCi (BJ0H) 04.2004 →	G9T 702	D	1.2 (SB0A, SB0F, SB10) 03.1999 → 10.2003	D7F 726	B
2.2 dCi (BJ0M) 12.2004 →	G9T 700	D	1.2 (SB0A, SB0F, SB10) 03.1999 → 10.2003	D7F 746	B
2.2 dCi (BJ0M) 12.2004 →	G9T 702	D	1.2 (SB0A, SB0F, SB1K, SB2D) 09.1998 →	D7F 720	B
<b>WIND (E4M_)</b>			1.2 (SB0A, SB0F, SB1K, SB2D) 09.1998 →	D7F 726	B
1.2 (E4MF) 07.2010 →	D4F 782	B	1.2 (SB0A, SB0F, SB1K, SB2D) 09.1998 →	D7F 746	B
1.2 TCe 100 (E4MA) 02.2011 →	D4F 780	B	1.5 dCi 06.2001 → 10.2004	K9K 702	D
1.6 (E4MB, E4MC) 07.2010 →	K4M 854	B	1.5 dCi 11.2003 →	K9K 702	D
			1.5 dCi 11.2003 →	K9K 710	D
<b>11 Hatchback Van (S37_)</b>			1.5 dCi 11.2003 →	K9K 716	D
1.1 (S371) 03.1983 → 06.1986	C1E 715	B	1.5 dCi 04.2004 →	K9K 714	D
1.1 (S371) 03.1983 → 06.1986	C1E 720	B	1.5 dCi (SB07) 06.2001 →	K9K 700	D
1.2 (S37S) 10.1984 → 12.1988	C1G 700	B	1.5 dCi (SB07) 06.2001 →	K9K 704	D
1.2 (S37S) 10.1984 → 12.1988	C1G 710	B	1.6 (SB0H) 11.2003 →	K4M 746	B
1.4 (S372) 03.1983 → 09.1986	C1J 715	B	1.9 D (SB0E) 09.1998 →	F8Q 630	D
1.4 (S372) 03.1983 → 09.1986	C2J 730	B	1.9 D (SB0J) 02.2000 → 05.2001	F8Q 632	D
1.4 (S373) 10.1985 → 12.1986	C2J 768	B	1.9 D (SB0R) 03.1999 → 01.2000	F8Q 662	D
1.6 D (S374) 08.1983 → 12.1988	F8M 700	D	1.9 DTi (SB0U) 02.2000 → 05.2001	F9Q 780	D
1.6 D (S374) 08.1983 → 12.1988	F8M 720	D	<b>CLIO III Hatchback Van (SB_ , SR_)</b>		
1.6 D (S374) 08.1983 → 12.1988	F8M 730	D	1.2 (SR0J) 11.2005 → 12.2014	D4F 740	BG
<b>12 Estate Van</b>			1.2 (SR0P) 11.2007 → 12.2011	D4F 784	B
1.3 07.1975 → 04.1980	810.02	B	1.2 Hi-Flex (SR1U) 11.2007 → 12.2009	D4F 742	AB
<b>18 Estate Van</b>			1.5 dCi 06.2005 → 07.2010	K9K 766	D
1.4 05.1979 → 07.1986	847 720	B	1.5 dCi 10.2005 → 10.2007	K9K 764	D
1.4 05.1979 → 07.1986	847 722	B	1.5 dCi 10.2005 → 10.2007	K9K 772	D
2.1 Diesel 11.1981 → 07.1986	852 710	D	1.5 dCi 10.2005 → 07.2010	K9K 768	D
2.1 Diesel 11.1981 → 07.1986	J8S 711	D	1.5 dCi 08.2010 → 12.2014	K9K 770	D
<b>19 I Hatchback Van (S53_)</b>			1.5 dCi (SR1H) 08.2010 → 12.2014	K9K 770	D
1.2 01.1988 → 12.1992	C1G 730	B	<b>CLIO IV Grandtour (KH_)</b>		
1.4 01.1988 → 12.1992	E6J 700	B	0.9 TCe 90 01.2014 →	H4B 400	B
1.9 D 09.1988 → 12.1992	F8Q 706	D	1.5 dCi 75 01.2014 →	K9K 612	D
1.9 D 09.1990 → 12.1992	F8Q 742	D	1.5 dCi 90 01.2014 →	K9K 608	D
<b>19 II Hatchback Van (S53_)</b>			<b>CLIO IV Hatchback Van (BH_)</b>		
1.2 03.1992 → 12.1995	C1G 730	B	0.9 TCe 90 01.2014 →	H4B 400	B
1.4 03.1992 → 12.1995	E6J 700	B	0.9 TCe 90 01.2014 →	H4B 408	B
1.9 D 03.1992 → 12.1995	F8Q 706	D	0.9 TCe 90 LPG (BHM1) 08.2015 →	H4B 410	B
1.9 D 03.1992 → 12.1995	F8Q 742	D	1.2 16V 01.2014 →	D4F 722	B
1.9 dT 03.1992 → 12.1995	F8Q 740	D	1.2 16V (BHMK) 01.2014 →	D4F 740	BG
<b>21 Estate Van (S48_)</b>			1.2 16V LPG (BHMKG) 01.2014 →	D4F 744	BG
1.7 06.1986 → 03.1992	F2N 710	B	1.5 dCi 75 01.2014 →	K9K 612	D
1.9 D 06.1986 → 08.1994	F8Q 710	D	1.5 dCi 90 (BHAJ) 01.2014 →	K9K 608	D
2.1 D 06.1986 → 08.1994	J8S 704	D	1.5 dCi 90 (BHAJ) 01.2014 →	K9K 628	D
<b>4 Box Body/MPV (R21_ , R23_)</b>			1.5 dCi 90 (BHAJ) 01.2014 →	K9K 629	D
1.1 (2370, 210B) 10.1976 → 07.1989	C1E 714	B	<b>DOKKER</b>		
1.1 (2370, 210B) 10.1976 → 07.1989	C1E 718	B	1.5 dCi 12.2013 →	K9K 612	D
1.1 (2370, 210B) 10.1976 → 07.1989	C1E 719	B	<b>ESPACE II VAN (J/S63_)</b>		
1.1 (239B) 07.1982 → 05.1989	C1E 718	B	2.1 TD (S635, S63D) 06.1992 → 10.1996	J8S 610	D
1.1 (239B) 07.1982 → 05.1989	C1E 719	B	2.1 TD (S635, S63D) 06.1992 → 10.1996	J8S 772	D
<b>5 Hatchback Van (238_)</b>			2.2 (S637) 06.1992 → 10.1996	J7T 772	B
1.1 09.1980 → 12.1985	C1E 750	B	<b>ESTAFETTE (213_)</b>		
1.1 09.1980 → 12.1985	C1E 752	B	1.1 02.1962 → 12.1981	688.01	B
1.1 09.1980 → 12.1985	C1E 754	B	1.3 08.1969 → 12.1981	810.01	B
1.1 01.1981 → 12.1985	C1E 726	B	<b>KANGOO Express (FC0/1_)</b>		
1.3 (2387) 09.1976 → 09.1979	810 726	B	1.0 01.2002 → 01.2007	D4D 700	B
<b>CLIO I Hatchback Van (S57_)</b>			1.0 01.2002 → 01.2007	D4D 720	B
1.1 01.1991 → 09.1998	C1E 700	B	1.2 (FC01, FC0A, FC0F) 08.1997 →	D7F 720	B
1.2 01.1991 → 09.1998	E5F 710	B	1.2 (FC01, FC0A, FC0F) 08.1997 →	D7F 722	B
1.2 01.1991 → 09.1998	E7F 706	B	1.2 (FC01, FC0A, FC0F) 08.1997 →	D7F 726	B
1.2 01.1994 → 09.1998	E7F 750	B	1.2 (FC01, FC0A, FC0F) 08.1997 →	D7F 744	B
1.2 01.1996 → 12.1996	C3G 720	B	1.2 (FC01, FC0A, FC0F) 08.1997 →	D7F 746	B
			1.2 (FC01, FC0A, FC0F) 03.1998 →	D7F 710	B
			1.2 (FC1A) 07.1998 → 07.2001	D7F 710	B

R



			Pos				Pos		
1.2 (FC1A)	07.1998 → 07.2001	D7F 722	B	4	1.5 dCi 110 (FW06, FW12)	09.2013 →	K9K 646	D	21
1.2 (FC1A)	07.1998 → 07.2001	D7F 744	B	4	1.5 dCi 110 (FW06, FW12)	09.2013 →	K9K 647	D	21
1.2 (FC1A)	07.1998 → 07.2001	D7F 764	B	4	1.5 dCi 110 (FW0C, FW0H)	09.2010 →	K9K 804	D	19
1.2 (FC1A)	07.1998 → 07.2001	D7F 766	B	4	1.5 dCi 110 (FW0C, FW0H)	09.2010 →	K9K 816	D	21
1.2 16V (FC05, FC0W, FC1D, FC1P, FC1K, FC0T)	10.2001 →	D4F 712	B	5	1.5 dCi 115 (FW17)	10.2019 →	K9K 872	D	25
1.2 16V (FC05, FC0W, FC1D, FC1P, FC1K, FC0T)	10.2001 →	D4F 714	B	5	1.5 dCi 70 (FW0A, KW0V)	02.2008 →	K9K 800	D	19
1.2 16V (FC05, FC0W, FC1D, FC1P, FC1K, FC0T)	10.2001 →	D4F 730	B	5	1.5 dCi 75 (FW07, FW10, FW04)	09.2010 →	K9K 608	D	21
1.2 BiFuel	07.1998 → 07.2001	D7F 710	B	4	1.5 dCi 75 (FW07, FW10, FW04)	09.2010 →	K9K 628	D	21
1.2 BiFuel	07.1998 → 07.2001	D7F 744	B	4	1.5 dCi 75 (FW07, FW10, FW04)	09.2010 →	K9K 808	D	21
1.4 (FC0C, FC0B, FC0H, FCOM)	08.1997 → 06.2008	E7J 634	B	16	1.5 dCi 80 (FW15)	10.2019 →	K9K 872	D	25
1.4 (FC0C, FC0B, FC0H, FCOM)	08.1997 → 06.2008	E7J 635	B	16	1.5 dCi 85 (FW0K, FW0L, FW0B)	02.2008 →	K9K 802	D	19
1.4 (FC0C, FC0B, FC0H, FCOM)	08.1997 → 06.2008	K7J 700	B	16	1.5 dCi 85 (FW0K, FW0L, FW0B)	02.2008 →	K9K 812	D	21
1.4 (FC0C, FC0B, FC0H, FCOM)	08.1997 → 06.2008	K7J 701	B	16	1.5 dCi 90 (FW0G, FW05, FW08, FW11)	06.2009 →	K9K 608	D	21
1.4 (FC0C, FC0B, FC0H, FCOM)	03.1998 → 06.2008	E7J 780	B	16	1.5 dCi 90 (FW0G, FW05, FW08, FW11)	06.2009 →	K9K 628	D	21
1.5 dCi	10.2005 →	K9K 716	D	19	1.5 dCi 90 (FW0G, FW05, FW08, FW11)	06.2009 →	K9K 808	D	21
1.5 dCi (FC07, FC1R)	12.2001 →	K9K 700	D	18	1.5 dCi 90 (FW18)	08.2017 →	K9K 647	D	21
1.5 dCi (FC07, FC1R)	12.2001 →	K9K 702	D	18	1.5 dCi 95 (FW16)	10.2019 →	K9K 872	D	25
1.5 dCi (FC07, FC1R)	12.2001 →	K9K 704	D	18	1.6	02.2008 → 12.2009	K4M 706	B	33
1.5 dCi (FC08, FC09)	04.2003 →	K9K 702	D	18	1.6	02.2008 → 12.2009	K4M 730	B	33
1.5 dCi (FC08, FC09)	04.2003 →	K9K 710	D	18	1.6 (FW00, FW0E, FW0N, FW0P, FW0Y)	02.2008 →	K7M 750	B	32
1.5 dCi (FC1E)	06.2005 →	K9K 714	D	18	1.6 16V (FW03, FW09, FW0D, FW0U, FW0W, FW13)	02.2008 →	K4M 830	B	33
1.5 dCi (FC1G)	06.2005 →	K9K 718	D	20	1.6 16V (FW03, FW09, FW0D, FW0U, FW0W, FW13)	02.2008 →	K4M 831	B	35
1.5 dCi (FC1R)	12.2002 →	K9K 704	D	18	1.6 16V (FW03, FW09, FW0D, FW0U, FW0W, FW13)	02.2008 →	K4M 834	B	35
1.6	10.1998 → 06.2001	K7M 746	B	32	1.6 16V FLEX (FW01)	02.2008 →	K4M 834	B	35
1.6	09.1999 → 06.2001	K7M 746	B	32	1.6 16V LPG (FW03, FW09, FW0W)	02.2008 →	K4M 834	B	35
1.6	01.2002 → 02.2007	K4M 850	AB	39	1.6 S Ce (FW17)	10.2019 →	K4M 830	B	33
1.6 16V	10.2001 →	K4M 706	B	33	<b>LOGAN EXPRESS (US )</b>				
1.6 16V	10.2001 →	K4M 752	B	33	1.5 dCi	04.2007 →	K9K 792	D	24
1.6 16V 4x4 (FC0L, FC0P, FC0S)	10.2001 →	K4M 750	B	33	1.6	04.2007 →	K7M 710	B	32
1.6 16V 4x4 (FC0L, FC0P, FC0S)	10.2001 →	K4M 752	B	33	<b>MASTER</b>				
1.6 16V 4x4 (FC0L, FC0P, FC0S)	10.2001 →	K4M 753	B	33	2.4 TD	01.1986 → 06.1994	8140.21.235	D	101
1.6 16V bivalent	06.2005 →	K4M 850	AB	39	2.5 TD	09.1980 →	8140.47.2785	D	100
1.6 Flex	03.2007 → 12.2018	K4M 850	AB	39	2.5 TD	01.1986 → 07.1996	8140.27.2582	D	100
1.9 D (FC0J)	09.1999 → 06.2003	F8Q 632	D	45	2.5 TD	08.1990 → 08.1996	8140.27.2565	D	106
1.9 dCi (FC0V)	07.2003 →	F9Q 782	D	50	2.5 TD	10.1991 → 07.1996	8140.47.2530	D	103
1.9 dCi (FC0V)	07.2003 →	F9Q 790	D	50	2.5 TD	01.1994 → 09.1997	8140.27.2590	D	105
1.9 dCi 4x4 (FC0V)	10.2001 →	F9Q 782	D	50	<b>MASTER I Bus (T_)</b>				
1.9 dCi 4x4 (FC0V)	10.2001 →	F9Q 790	D	50	2.0	06.1985 → 10.1989	J5R 728	B	95
1.9 dTi (FC0U)	02.2000 →	F9Q 780	D	50	2.1 D	11.1989 → 04.1995	J8S 330	D	89
D 55 1.9 (FC0D)	03.1998 →	F8Q 662	D	47	2.4 D	09.1986 → 10.1989	S8U 731	D	99
D 65 1.9 (FC0E, FC02, FC0J, FC0N)	08.1997 →	F8Q 632	D	45	28-35 2.0	10.1986 → 07.1998	J5R 718	B	95
D 65 1.9 (FC0E, FC02, FC0J, FC0N)	03.1998 →	F8Q 630	D	47	28-35 2.1 D	08.1980 → 07.1998	J8S 330	D	89
<b>KANGOO Express (FW0/1_)</b>					28-35 2.4 D	08.1980 → 08.1989	8140.61.2300	D	98
1.2 TCe 115 (FW02, FW14)	07.2013 →	H5F 400	B	10	28-35 2.4 D	08.1980 → 08.1989	S8U 731	D	99
1.2 TCe 115 (FW02, FW14)	07.2013 →	H5F 408	B	10	28-35 2.5 D	08.1989 → 07.1998	8140.67.2510	D	102
1.2 TCe 115 (FW02, FW14)	07.2013 →	H5F 412	B	10	28-35 2.5 D	08.1989 → 07.1998	S8U 742	D	99
1.5 dCi	05.2008 → 01.2014	K9K 700	D	18	30 2,2	08.1980 → 07.1998	J7T 782	B	95
1.5 dCi 105 (FW0F)	02.2008 →	K9K 806	D	21	30 2,2	01.1994 → 07.1998	J7T 788	B	95
1.5 dCi 110 (FW06, FW12)	09.2013 →	K9K 636	D	21	35 2,5 TD	08.1989 → 07.1998	8140.27.2500	D	100
					35 2,5 TD	08.1989 → 07.1998	8140.27.2510	D	100

R

		Pos			Pos					
35 2,5 TD	01.1994 → 07.1998	S9U 714	D	99	2.5 dCi	10.2004 → 02.2012	G9U 724	D	96	
<b>MASTER I Platform/Chassis (P_)</b>						2.5 dCi	08.2006 → 01.2010	G9U 650	D	96
2.0	11.1989 → 07.1993	J5R 718	B	95	2.5 dCi	08.2006 →	G9U 632	D	96	
2.1 D	11.1989 → 07.1993	J8S 330	D	89	2.5 dCi	08.2006 →	G9U 650	D	96	
2.2	08.1993 → 02.1998	J7T 788	B	95	2.5 dCi 100 (FD0U, FD0V)	10.2003 →	G9U 754	D	96	
2.4 D	08.1993 → 02.1998	S8U 730	D	99	2.5 dCi 120	10.2001 →	G9U 720	D	96	
2.5 D	05.1989 → 10.1989	S8U 742	D	99	2.5 dCi 120	10.2001 →	G9U 724	D	96	
2.5 DT	11.1989 → 10.1993	S9U 702	D	99	2.5 dCi 120	10.2001 →	G9U 750	D	96	
2.5 DT	08.1993 → 02.1998	S9U 740	D	99	2.5 dCi 120	10.2001 →	G9U 754	D	96	
28-35 2.0	10.1986 → 07.1998	J5R 728	B	95	2.5 dCi 4x4	06.2006 → 03.2013	G9U 724	D	96	
28-35 2.5 D	09.1980 → 07.1998	8140.61.2300	D	98	2.8 dTi	07.1998 → 10.2001	S9W 702	D	107	
28-35 2.5 D	09.1980 → 07.1998	S8U 731	D	99	2.8 dTi 4x4	01.2002 → 09.2004	S9W 702	D	107	
<b>MASTER I Van (T_)</b>						<b>MASTER III Bus (JV)</b>				
2.4 D	07.1980 → 06.1983	S8U 731	D	99	2.3 dCi 100 FWD (JV0A, JV0B, JV0G, JV0H)	02.2011 →	M9T 670	D	84	
2.4 D	07.1983 → 08.1986	S8U 730	D	99	2.3 dCi 100 FWD (JV0A, JV0B, JV0G, JV0H)	02.2011 →	M9T 672	D	84	
2.4 D	09.1986 → 12.1992	S8U 730	D	99	2.3 dCi 100 FWD (JV0A, JV0B, JV0G, JV0H)	02.2011 →	M9T 676	D	84	
28-35 2,5 D	08.1989 → 07.1998	8140.67.2510	D	102	2.3 dCi 100 FWD (JV0A, JV0B, JV0G, JV0H)	02.2011 →	M9T 870	D	85	
28-35 2,5 D	08.1989 → 07.1998	S8U 742	D	99	2.3 dCi 110 FWD (JV0R, JV0W)	09.2014 →	M9T 870	D	85	
28-35 2,5 TD	08.1989 → 07.1998	8140.27.2580	D	100	2.3 dCi 125 FWD (JV0C, JV0D, JV0H, JV0G, JV0J)	02.2011 →	M9T 670	D	84	
28-35 2,5 TD	08.1989 → 07.1998	S9U 702	D	99	2.3 dCi 125 FWD (JV0C, JV0D, JV0H, JV0G, JV0J)	02.2011 →	M9T 672	D	84	
28-35 2.0	10.1986 → 07.1998	J5R 718	B	95	2.3 dCi 125 FWD (JV0C, JV0D, JV0H, JV0G, JV0J)	02.2011 →	M9T 676	D	84	
28-35 2.1 D	08.1980 → 07.1998	J8S 330	D	89	2.3 dCi 130 FWD	05.2013 →	M9T 702	D	85	
28-35 2.4 D	08.1980 → 08.1989	8140.61.2300	D	98	2.3 dCi 135 FWD (JV0N, JV08)	07.2014 →	M9T 702	D	85	
28-35 2.4 D	08.1980 → 08.1989	S8U 731	D	99	2.3 dCi 145 FWD (JV0F, JV0S, JV0T)	02.2011 →	M9T 680	D	84	
30 2,2	08.1980 → 07.1998	J7T 782	B	95	2.3 dCi 145 FWD (JV0F, JV0S, JV0T)	02.2011 →	M9T 706	D	86	
30 2,2	01.1994 → 07.1998	J7T 788	B	95	2.3 dCi 150 FWD (JV0F, JV03)	10.2012 →	M9T 880	D	85	
35 2,5 TD	08.1989 → 07.1998	8140.27.2500	D	100	2.3 dCi 165 FWD (JV0P, JV0U)	07.2014 →	M9T 702	D	85	
35 2,5 TD	08.1989 → 07.1998	8140.27.2510	D	100	2.3 dCi 170 FWD (JV0L)	07.2015 →	M9T 706	D	86	
35 2,5 TD	08.1989 → 07.1998	S9U 740	D	99	<b>MASTER III Platform/Chassis (EV, HV, UV)</b>					
35 2,5 TD	01.1994 → 07.1998	S9U 714	D	99	2.3 dCi 100 FWD (EV0A, EV0B, HV0A, HV0B, UV0A, UV0B,...)	02.2010 →	M9T 670	D	84	
<b>MASTER II Bus (JD)</b>						2.3 dCi 100 FWD (EV0A, EV0B, HV0A, HV0B, UV0A, UV0B,...)	02.2010 →	M9T 672	D	84
1.9 dCi 80	11.2001 →	F9Q 772	D	50	2.3 dCi 100 FWD (EV0A, EV0B, HV0A, HV0B, UV0A, UV0B,...)	02.2010 →	M9T 676	D	84	
1.9 dCi 80	11.2001 →	F9Q 774	D	49	2.3 dCi 100 RWD (HV0B, UV0B)	02.2010 →	M9T 690	D	84	
1.9 dTi	09.2000 →	F9Q 770	D	50	2.3 dCi 110 FWD (EV0R, EV0W, HV0R, HV0W, UV0R, UV0W)	09.2014 →	M9T 870	D	85	
2.2 dCi 90	09.2000 →	G9T 720	D	94						
2.2 dCi 90	09.2000 →	G9T 722	D	94						
2.2 dCi 90	09.2000 →	G9T 750	D	94						
2.5 D	07.1998 → 01.2001	S8U 770	D	99						
2.5 dCi	08.2006 →	G9U 632	D	96						
2.5 dCi	08.2006 →	G9U 650	D	96						
2.5 dCi	08.2006 →	G9U 650	D	96						
2.5 dCi 100 (JDCV)	10.2003 →	G9U 754	D	96						
2.5 dCi 120	10.2001 →	G9U 720	D	96						
2.5 dCi 120	10.2001 →	G9U 750	D	96						
2.5 dCi 120	10.2001 →	G9U 754	D	96						
2.8 dTi	07.1998 → 10.2001	S9W 702	D	107						
<b>MASTER II Platform/Chassis (ED/HD/UD)</b>										
2.2 dCi 90	09.2000 →	G9T 720	D	94						
2.2 dCi 90	09.2000 →	G9T 722	D	94						
2.2 dCi 90	09.2000 →	G9T 750	D	94						
2.5 D	07.1998 → 01.2001	S8U 770	D	99						
2.5 dCi	08.2006 →	G9U 632	D	96						
2.5 dCi	08.2006 →	G9U 650	D	96						
2.5 dCi	08.2006 →	G9U 650	D	96						
2.5 dCi 100 (ED4V, ED8V)	10.2003 →	G9U 754	D	96						
2.5 dCi 120	10.2001 →	G9U 720	D	96						
2.5 dCi 120	10.2001 →	G9U 724	D	96						
2.5 dCi 120	10.2001 →	G9U 750	D	96						
2.5 dCi 120	10.2001 →	G9U 754	D	96						
2.8 dTi	07.1998 → 10.2001	S9W 702	D	107						
<b>MASTER II Van (FD)</b>										
1.9 dCi 80	11.2001 →	F9Q 772	D	50						
1.9 dCi 80	11.2001 →	F9Q 774	D	49						
1.9 dTi	09.2000 →	F9Q 770	D	50						
2.2 dCi 90	09.2000 →	G9T 720	D	94						
2.2 dCi 90	09.2000 →	G9T 722	D	94						
2.2 dCi 90	09.2000 →	G9T 750	D	94						
2.5 D	07.1998 → 01.2001	S8U 770	D	99						

		Pos			Pos		
2.3 dCi 125 FWD (EV0C, 02.2010 → EV0D, EV0J, HV0C, HV0D, HV0H,...)	M9T 670	D	84	2.3 dCi 150 FWD (EV0F, 03.2013 → HV0F, UV0F, EV03, HV03, UV03)	M9T 880	D	85
2.3 dCi 125 FWD (EV0C, 02.2010 → EV0D, EV0J, HV0C, HV0D, HV0H,...)	M9T 672	D	84	2.3 dCi 150 RWD (HV0F, 03.2013 → UV0F)	M9T 896	D	86
2.3 dCi 125 FWD (EV0C, 02.2010 → EV0D, EV0J, HV0C, HV0D, HV0H,...)	M9T 676	D	84	2.3 dCi 150 RWD (HV0F, 03.2013 → UV0F)	M9T 898	D	86
2.3 dCi 125 FWD (EV0C, 02.2010 → EV0D, EV0J, HV0C, HV0D, HV0H,...)	M9T 680	D	84	2.3 dCi 165 FWD (EV0P, 07.2014 → EV0U, EV11, EV12, HV0P, HV0U,...)	M9T 702	D	85
2.3 dCi 125 FWD (EV0C, 02.2010 → EV0D, EV0J, HV0C, HV0D, HV0H,...)	M9T 680	D	84	2.3 dCi 165 RWD (HV0P, 07.2014 → HV0U, HV10, HV12, UV0P, UV0U,...)	M9T 700	D	85
2.3 dCi 125 FWD (EV0C, 02.2010 → EV0D, EV0J, HV0C, HV0D, HV0H,...)	M9T 670	D	84	2.3 dCi 170 FWD (EV0L, 06.2016 → HV0L, UV0L)	M9T 706	D	86
2.3 dCi 125 FWD (EV0C, 02.2010 → EV0D, EV0J, HV0C, HV0D, HV0H,...)	M9T 872	D	85	<b>MASTER III Van (FV)</b>			
2.3 dCi 125 FWD (EV0C, 02.2010 → EV0D, EV0J, HV0C, HV0D, HV0H,...)	M9T 880	D	85	2.3 dCi 100 FWD (FV0A, 02.2010 → FV0B, FV0G, FV0K, FV0H)	M9T 670	D	84
2.3 dCi 125 RWD (HV0C, 02.2010 → HV0D, UV0C, UV0D, UV0H, UV0J,...)	M9T 686	D	84	2.3 dCi 100 FWD (FV0A, 02.2010 → FV0B, FV0G, FV0K, FV0H)	M9T 672	D	84
2.3 dCi 125 RWD (HV0C, 02.2010 → HV0D, UV0C, UV0D, UV0H, UV0J,...)	M9T 690	D	84	2.3 dCi 100 FWD (FV0A, 02.2010 → FV0B, FV0G, FV0K, FV0H)	M9T 676	D	84
2.3 dCi 125 RWD (HV0C, 02.2010 → HV0D, UV0C, UV0D, UV0H, UV0J,...)	M9T 692	D	84	2.3 dCi 100 FWD (FV0A, 02.2010 → FV0B, FV0G, FV0K, FV0H)	M9T 870	D	85
2.3 dCi 125 RWD (HV0C, 02.2010 → HV0D, UV0C, UV0D, UV0H, UV0J,...)	M9T 696	D	84	2.3 dCi 100 RWD (FV0B) 02.2010 →	M9T 690	D	84
2.3 dCi 125 RWD (HV0C, 02.2010 → HV0D, UV0C, UV0D, UV0H, UV0J,...)	M9T 698	D	84	2.3 dCi 100 RWD (FV0B) 02.2010 →	M9T 890	D	85
2.3 dCi 125 RWD (HV0C, 02.2010 → HV0D, UV0C, UV0D, UV0H, UV0J,...)	M9T 882	D	85	2.3 dCi 110 FWD (FV0R, 09.2014 → FV0W)	M9T 870	D	85
2.3 dCi 125 RWD (HV0C, 02.2010 → HV0D, UV0C, UV0D, UV0H, UV0J,...)	M9T 890	D	85	2.3 dCi 125 FWD (FV0C, 02.2010 → FV0D, FV0G, FV0H, FV0J, FV0K)	M9T 670	D	84
2.3 dCi 125 RWD (HV0C, 02.2010 → HV0D, UV0C, UV0D, UV0H, UV0J,...)	M9T 896	D	86	2.3 dCi 125 FWD (FV0C, 02.2010 → FV0D, FV0G, FV0H, FV0J, FV0K)	M9T 672	D	84
2.3 dCi 125 RWD (HV0C, 02.2010 → HV0D, UV0C, UV0D, UV0H, UV0J,...)	M9T 898	D	86	2.3 dCi 125 FWD (FV0C, 02.2010 → FV0D, FV0G, FV0H, FV0J, FV0K)	M9T 676	D	84
2.3 dCi 130 FWD (EV0Y, 03.2012 → HV0Y, UV0M, UV0Y)	M9T 882	D	85	2.3 dCi 125 FWD (FV0C, 02.2010 → FV0D, FV0G, FV0H, FV0J, FV0K)	M9T 870	D	85
2.3 dCi 135 FWD (EV0N, 07.2014 → HV0N, UV0N, EV08, HV08, UV08)	M9T 702	D	85	2.3 dCi 125 FWD (FV0C, 02.2010 → FV0D, FV0G, FV0H, FV0J, FV0K)	M9T 872	D	85
2.3 dCi 135 RWD (HV0N, 07.2014 → UV0N)	M9T 700	D	85	2.3 dCi 125 FWD (FV0C, 02.2010 → FV0D, FV0G, FV0H, FV0J, FV0K)	M9T 880	D	85
2.3 dCi 145 FWD (EV0E, 02.2010 → EV0F, HV0E, HV0F, UV0E, UV0F,...)	M9T 678	D	84	2.3 dCi 125 FWD (FV0C, 02.2010 → FV0D, FV0G, FV0H, FV0J, FV0K)	M9T 882	D	85
2.3 dCi 145 FWD (EV0E, 02.2010 → EV0F, HV0E, HV0F, UV0E, UV0F,...)	M9T 680	D	84	2.3 dCi 125 RWD (FV0C, 02.2010 → FV0D, FV0H, FV0J, FV0A, FV0K)	M9T 686	D	84
2.3 dCi 145 FWD (EV0E, 02.2010 → EV0F, HV0E, HV0F, UV0E, UV0F,...)	M9T 706	D	86	2.3 dCi 125 RWD (FV0C, 02.2010 → FV0D, FV0H, FV0J, FV0A, FV0K)	M9T 690	D	84
2.3 dCi 145 RWD (UV0F, 02.2010 → UV0E, HV0E, HV0F, HV0T, HV10,...)	M9T 694	D	84	2.3 dCi 125 RWD (FV0C, 02.2010 → FV0D, FV0H, FV0J, FV0A, FV0K)	M9T 692	D	84
2.3 dCi 145 RWD (UV0F, 02.2010 → UV0E, HV0E, HV0F, HV0T, HV10,...)	M9T 696	D	84	2.3 dCi 125 RWD (FV0C, 02.2010 → FV0D, FV0H, FV0J, FV0A, FV0K)	M9T 696	D	84
2.3 dCi 145 RWD (UV0F, 02.2010 → UV0E, HV0E, HV0F, HV0T, HV10,...)	M9T 698	D	84	2.3 dCi 125 RWD (FV0C, 02.2010 → FV0D, FV0H, FV0J, FV0A, FV0K)	M9T 698	D	84

**R**

			Pos				Pos
2.3 dCi 125 RWD (FV0C, 02.2010 → FV0D, FV0H, FV0J, FV0A, FV0K)	M9T 890	D	85	1.9 DT (JA0K) 01.1997 → 09.1999	F8Q 786	D	44
				1.9 DTi (JA0N) 04.1997 → 09.1999			
<b>Megane I Kombi van (KA_)</b>							
2.3 dCi 125 RWD (FV0C, 02.2010 → FV0D, FV0H, FV0J, FV0A, FV0K)	M9T 896	D	86	1.4 (KA0D) 04.2001 → 07.2003	K4J 714	B	33
				1.4 (KA0D) 04.2001 → 07.2003	K4J 750	B	33
2.3 dCi 125 RWD (FV0C, 02.2010 → FV0D, FV0H, FV0J, FV0A, FV0K)	M9T 898	D	86	1.6 (KA0B, KA04) 04.2001 → 07.2003	K4M 700	B	33
				1.6 (KA0B, KA04) 04.2001 → 07.2003	K4M 701	B	33
2.3 dCi 125 RWD (FV0C, 02.2010 → FV0D, FV0H, FV0J, FV0A, FV0K)	M9T 898	D	86	1.6 (KA0B, KA04) 04.2001 → 07.2003	K4M 708	B	33
				1.6 (KA0B, KA04) 04.2001 → 07.2003	K4M 709	B	33
2.3 dCi 130 FWD (FV0M, 06.2016 → FV0Y)	M9T 882	D	85	1.6 BiFuel (KA04) 04.2001 → 07.2003	K4M 704	B	33
				1.6 BiFuel (KA0B) 04.2001 → 07.2003	K4M 712	B	33
2.3 dCi 135 FWD (FV0N, 07.2014 → FV08)	M9T 702	D	85	1.8 (KA1M) 04.2001 → 07.2003	F4P 722	B	65
				1.9 D (KA0R) 02.2000 → 09.2000	F8Q 622	D	41
2.3 dCi 135 RWD (FV0N) 07.2014 →	M9T 700	D	85	1.9 DTi (KA1U) 04.2001 → 07.2003	F9Q 744	D	51
2.3 dCi 145 FWD (FV0E, 02.2010 → FV0F, FV0H, FV02, FV0M, FV0S,...)	M9T 678	D	84	1.9 dCi (KA05) 04.2001 → 07.2003	F9Q 732	D	50
				1.9 dCi (KA05) 04.2001 → 07.2003	F9Q 732	D	50
2.3 dCi 145 FWD (FV0E, 02.2010 → FV0F, FV0H, FV02, FV0M, FV0S,...)	M9T 680	D	84	1.9 dCi (KA05) 04.2001 → 07.2003	F9Q 733	D	50
				1.9 dCi (KA05) 04.2001 → 07.2003	F9Q 733	D	50
<b>RAPID Box Body/MPV (F40_, G40_)</b>							
2.3 dCi 145 FWD (FV0E, 02.2010 → FV0F, FV0H, FV02, FV0M, FV0S,...)	M9T 706	D	86	1.0 09.1985 → 08.1991	C1C 706	B	2
				1.0 02.1986 → 05.1992	C1C 706	B	2
				1.1 09.1985 → 06.1990	C1E 750	B	7
2.3 dCi 145 RWD (FV0E, 02.2010 → FV0F, FV0T, FV10, FV12)	M9T 694	D	84	1.1 09.1993 → 04.1995	C1E 762	B	7
				1.1 (F401) 07.1985 → 06.1989	C1E 752	B	7
2.3 dCi 145 RWD (FV0E, 02.2010 → FV0F, FV0T, FV10, FV12)	M9T 696	D	84	1.1 (F401) 07.1985 → 06.1990	C1E 750	B	7
				1.1 (F401) 07.1985 → 08.1991	C1E 754	B	7
2.3 dCi 145 RWD (FV0E, 02.2010 → FV0F, FV0T, FV10, FV12)	M9T 698	D	84	1.1 (F401) 07.1985 → 08.1991	C1E 760	B	7
				1.1 (F401) 07.1985 → 08.1991	C1E 792	B	7
2.3 dCi 150 FWD (FV0F, 03.2013 → FV03)	M9T 880	D	85	1.1 (F401) 09.1991 → 04.1995	C1E 762	B	7
				1.1 (F40H) 06.1987 → 07.1989	C1E 756	B	7
2.3 dCi 150 RWD (FV0F) 03.2013 →	M9T 896	D	86	1.2 09.1991 → 08.1993	C1G 726	B	8
2.3 dCi 150 RWD (FV0F) 03.2013 →	M9T 898	D	86	1.2 (F406, G40A) 09.1991 → 03.1998	C3G 710	B	14
2.3 dCi 165 FWD (FV0P, 07.2014 → FV0U, FV11, FV12)	M9T 702	D	85	1.2 (F406, G40A) 09.1991 → 03.1998	C3G 712	B	14
				1.4 09.1991 → 08.1993	E7J 724	B	16
2.3 dCi 165 RWD (FV0P, 07.2014 → FV0U, FV10, FV12)	M9T 700	D	85	1.4 05.1995 → 08.1997	E7J 773	B	16
				1.4 (F402) 07.1985 → 08.1991	C1J 768	B	17
2.3 dCi 170 FWD (FV0L) 07.2015 →	M9T 706	D	86	1.4 (F402) 07.1985 → 08.1991	C1J 780	B	17
				1.4 (F40D) 01.1994 → 03.1998	E7J 728	B	16
<b>MEGANE I Hatchback Van (SA0/1_)</b>							
1.9 (SA0U, SA0R, SA0A) 08.1995 → 09.2000	F8Q 620	D	42	1.4 (F40M) 03.1986 → 08.1991	C2J 784	B	17
1.9 (SA0U, SA0R, SA0A) 08.1995 → 09.2000	F8Q 622	D	41	1.4 (F40U, F40V) 09.1991 → 09.1995	E7J 720	B	16
1.9 (SA0U, SA0R, SA0A) 08.1995 → 09.2000	F8Q 624	D	42	1.4 (F40U, F40V) 09.1991 → 09.1995	E7J 724	B	16
1.9 dCi 10.2000 → 07.2003	F9Q 738	D	51	1.4 (F40U, F40V) 09.1991 → 09.1995	E7J 726	B	16
<b>MEGANE II Estate Van (KM_)</b>							
1.5 dCi (KM02) 08.2003 → 07.2009	K9K 728	D	18	1.4 (F40U, F40V) 09.1991 → 09.1995	E7J 773	B	16
1.5 dCi (KM0F) 08.2003 → 07.2009	K9K 722	D	18	1.4 (F40Y, F40A, F40V) 09.1991 → 08.1997	E6J 734	B	16
1.5 dCi (KM1E) 08.2003 → 07.2009	K9K 732	D	19	1.4 (F40Y, F40A, F40V) 09.1991 → 08.1997	E6J 738	B	16
1.5 dCi (KM1F) 05.2005 → 07.2009	K9K 724	D	19	1.4 (F40Y, F40A, F40V) 09.1991 → 08.1997	E7J 720	B	16
1.6 (KM0C) 10.2003 → 01.2008	K4M 780	B	35	1.4 Cat (F407) 08.1988 → 08.1991	C3J 760	B	15
1.9 dCi (KM14) 02.2006 → 10.2006	F9Q E 804	D	51	1.4 Cat (F407) 08.1988 → 03.1998	C3J 700	B	17
<b>MEGANE II Hatchback Van (KM0/2_)</b>							
1.5 dCi 08.2003 → 02.2008	K9K 722	D	18	1.4 Cat (F407) 09.1991 → 03.1998	C3J 762	B	15
1.5 dCi 08.2003 → 02.2008	K9K 728	D	18	1.4 RN 09.1991 → 08.1993	E6J 734	B	16
1.5 dCi 04.2005 → 02.2008	K9K 724	D	19	1.6 08.1996 → 11.2001	K4M 706	B	33
1.5 dCi 05.2005 → 02.2008	K9K 732	D	19	1.6 D 09.1993 → 04.1995	F8M 736	D	30
1.5 dCi 01.2007 → 03.2009	K9K 734	D	19	1.6 D (F404) 03.1986 → 08.1991	F8M 720	D	30
<b>MEGANE III Combi Van (KZ0/1_)</b>							
1.5 dCi 01.2009 → 08.2015	K9K 836	D	21	1.6 D (F404) 03.1986 → 08.1991	F8M 730	D	30
1.5 dCi 01.2009 → 08.2015	K9K 837	D	21	1.6 D (F404) 09.1991 → 08.1998	F8M 736	D	30
1.5 dCi 03.2010 → 08.2015	K9K 830	D	25	1.6 D (F404) 09.1991 → 08.1998	F8M 760	D	30
1.5 dCi 03.2010 → 08.2015	K9K 832	D	21	1.9 D (F40P, F40N, F40E) 09.1991 → 10.1992	F8Q 722	D	42
1.5 dCi (KZ1A) 03.2010 → 08.2015	K9K 834	D	21	1.9 D (F40P, F40N, F40E) 09.1991 → 03.1998	F8Q 646	D	42
<b>MEGANE III Hatchback Van (BZ_)</b>							
1.5 dCi (BZ0C, BZ1A) 11.2008 → 08.2015	K9K 834	D	21	1.9 D (F40P, F40N, F40E) 09.1991 → 03.1998	F8Q 724	D	42
1.5 dCi (BZ0D, BZ1G, BZ1F, BZ1M, BZ1W, BZ0R, BZ10)	K9K 836	D	21	1.9 D (F40P, F40N, F40E) 09.1991 → 03.1998	F8Q 776	D	42
				1.9 D (F40P, F40N, F40E) 10.1992 → 03.1998	F8Q 774	D	42
1.5 dCi (BZ0D, BZ1G, BZ1F, BZ1M, BZ1W, BZ0R, BZ10)	K9K 846	D	25	1.9 D (F40R) 09.1994 → 03.1998	F8Q 640	D	40
				1.9 D (F40R) 09.1994 → 03.1998	F8Q 648	D	43
<b>SCÉNIC I VAN (FA0_, JA0/1_)</b>							
MEGANE Scenic VAN (JA0/1_)				1.9 (FA0J) 09.1999 → 02.2001	F8Q 788	D	40
				1.9 (FA0J) 09.1999 → 02.2001	F8Q 790	D	45
				1.9 DTi (JA0N) 09.1999 → 04.2001	F9Q 734	D	46

R



Pos					Pos				
<b>SCÉNIC III VAN (JZ0/1_)</b>					2.5 D 4x4	08.1989 → 03.2001	S8U 758	D	<b>99</b>
1.5 dCi (JZ02)	01.2013 →	K9K 846	D	<b>25</b>	<b>TRAFIC II Bus (JL)</b>				
1.5 dCi (JZ0D, JZ1M, JZ09, JZ14, JZ1G, JZ1W, JZ10)	04.2009 →	K9K 836	D	<b>21</b>	1.9 dCi 100 (JLOC)	03.2001 →	F9Q 760	D	<b>50</b>
1.5 dCi (JZ0D, JZ1M, JZ09, JZ14, JZ1G, JZ1W, JZ10)	04.2009 →	K9K 837	D	<b>21</b>	1.9 dCi 80 (JLOB)	03.2001 →	F9Q 762	D	<b>50</b>
1.6 VVT (JZ0U, JZ1B, JZ1H, JZ1U, JZ24)	01.2013 →	K4M 858	B	<b>35</b>	1.9 dCi	04.2001 → 07.2003	F9Q 762	D	<b>50</b>
1.6 dCi (JZ00, JZ12, JZ2A)	01.2013 →	R9M 402	D	<b>52</b>	1.9 dCi	01.2012 → 12.2018	F9Q 760	D	<b>50</b>
<b>SUPER 5 Hatchback Van (S40_)</b>					2.0 (JLOA)	03.2001 →	F4R 720	B	<b>65</b>
1.1 (S401)	10.1984 → 06.1989	C1E 752	B	<b>7</b>	2.0 (JLOA)	03.2001 →	F4R 722	B	<b>65</b>
1.1 (S401)	10.1984 → 06.1990	C1E 750	B	<b>7</b>	2.0 16V	08.2006 →	F4R 820	B	<b>65</b>
1.1 (S401)	10.1984 → 08.1991	C1E 754	B	<b>7</b>	2.0 dCi 115	08.2006 →	M9R 692	D	<b>76</b>
1.2	07.1987 → 06.1989	C1G 702	B	<b>8</b>	2.0 dCi 115	08.2006 →	M9R 780	D	<b>77</b>
1.2 (S40F, S407)	01.1987 → 12.1996	C1G 702	B	<b>8</b>	2.0 dCi 115	08.2006 →	M9R 782	D	<b>77</b>
1.4	09.1985 → 07.1986	C3J 700	B	<b>17</b>	2.0 dCi 115	08.2006 →	M9R 786	D	<b>73</b>
1.4	06.1987 → 10.1987	C1J 788	B	<b>17</b>	2.5 dCi 115	02.2008 →	G9U 630	D	<b>96</b>
1.6 D (S404)	10.1984 → 12.1996	F8M 720	D	<b>30</b>	2.5 dCi 135 (JL0D)	05.2003 →	G9U 730	D	<b>96</b>
<b>TRAFIC</b>					2.5 dCi 145 (JL0J)	08.2006 →	G9U 630	D	<b>96</b>
110.150	10.1991 → 10.1991	798-20	D	<b>114</b>	<b>TRAFIC II Platform/Chassis (EL)</b>				
110.150	10.1991 → 01.1995	MIDS 06.02.12 B	D	<b>114</b>	1.9 dCi	09.2001 → 07.2003	F9Q 762	D	<b>50</b>
110.170	09.1985 → 01.1995	798-20	D	<b>114</b>	1.9 dCi 100 (EL0C)	03.2001 →	F9Q 760	D	<b>50</b>
2.0 dCi 16V	09.2006 →	M9R 780	D	<b>77</b>	1.9 dCi 80 (EL0B)	03.2001 →	F9Q 762	D	<b>50</b>
2.4 D	01.1981 → 12.1986	S8U 730	D	<b>99</b>	2.0 (EL0A)	03.2001 →	F4R 720	B	<b>65</b>
2.4 D	10.1981 → 01.1989	8140.61.240	D	<b>98</b>	2.0 16V	08.2006 →	F4R 820	B	<b>65</b>
75.130	06.1980 → 05.1991	797-20	D	<b>114</b>	2.0 dCi 115 (ELOH)	08.2006 →	M9R 692	D	<b>76</b>
85.150	09.1984 → 01.1995	798-20	D	<b>114</b>	2.0 dCi 115 (ELOH)	08.2006 →	M9R 780	D	<b>77</b>
95.130	06.1980 → 05.1991	797-20	D	<b>114</b>	2.0 dCi 115 (ELOH)	08.2006 →	M9R 782	D	<b>77</b>
P 862	01.1983 →	J5R A7	B	<b>95</b>	2.0 dCi 115 (ELOH)	08.2006 →	M9R 786	D	<b>73</b>
<b>TRAFIC Bus (T5, T6, T7)</b>					2.0 dCi 90 (ELOH)	08.2006 →	M9R 780	D	<b>77</b>
1.4	03.1980 → 04.1989	847 700	B	<b>17</b>	2.5 dCi	08.2007 →	G9U 630	D	<b>96</b>
1.4	03.1980 → 04.1989	847 701	B	<b>17</b>	2.5 dCi 135 (EL0D)	03.2001 →	G9U 730	D	<b>96</b>
1.4	03.1980 → 04.1989	C1J 700	B	<b>17</b>	2.5 dCi 145 (EL0J)	08.2006 →	G9U 630	D	<b>96</b>
1.7	06.1986 → 04.1989	F1N 724	B	<b>56</b>	<b>TRAFIC II Van (FL)</b>				
2.0	06.1986 → 04.1989	J5R 716	B	<b>95</b>	1.9 dCi	03.2001 →	F9Q 760	D	<b>50</b>
2.0	06.1986 → 04.1989	J5R 722	B	<b>95</b>	1.9 dCi	04.2001 → 07.2003	F9Q 762	D	<b>50</b>
2.0	06.1986 → 04.1989	J5R 726	B	<b>95</b>	1.9 dCi 100 (FLOC)	03.2001 →	F9Q 760	D	<b>50</b>
2.0 4x4	06.1986 → 04.1989	J5R 716	B	<b>95</b>	1.9 dCi 80 (FLOB)	03.2001 →	F9Q 760	D	<b>50</b>
2.0 4x4	06.1986 → 04.1989	J5R 722	B	<b>95</b>	1.9 dCi 80 (FLOB)	03.2001 →	F9Q 762	D	<b>50</b>
2.0 4x4	06.1986 → 04.1989	J5R 726	B	<b>95</b>	2.0 (FLOA)	03.2001 →	F4R 720	B	<b>65</b>
2.1 D	03.1985 → 04.1989	852 750	D	<b>89</b>	2.0 (FLOA)	03.2001 →	F4R 722	B	<b>65</b>
2.1 D 4x4	05.1985 → 02.1989	852 750	D	<b>89</b>	2.0 16V	08.2006 →	F4R 820	B	<b>65</b>
<b>TRAFIC Bus (TXW)</b>					2.0 dCi 115 (FLO1, FLOU)	08.2006 →	M9R 692	D	<b>76</b>
1.7	08.1992 → 08.1994	F1N 724	B	<b>56</b>	2.0 dCi 115 (FLO1, FLOU)	08.2006 →	M9R 780	D	<b>77</b>
1.9 D	06.1997 → 03.2001	F8Q 606	D	<b>42</b>	2.0 dCi 115 (FLO1, FLOU)	08.2006 →	M9R 782	D	<b>77</b>
2.0	05.1989 → 08.1990	J5R 726	B	<b>95</b>	2.0 dCi 115 (FLO1, FLOU)	08.2006 →	M9R 786	D	<b>73</b>
2.1 D	05.1989 → 06.1994	852 720	D	<b>89</b>	2.0 dCi 90 (FLOH)	08.2006 →	M9R 630	D	<b>73</b>
2.1 D	05.1989 → 06.1994	852 750	D	<b>89</b>	2.0 dCi 90 (FLOH)	08.2006 →	M9R 780	D	<b>77</b>
2.1 D	06.1994 → 10.1997	J8S 620	D	<b>89</b>	2.0 dCi 90 (FLOH)	08.2006 →	M9R 782	D	<b>77</b>
2.1 D	06.1994 → 10.1997	J8S 758	D	<b>89</b>	2.0 dCi 90 (FLOH)	08.2006 →	M9R 786	D	<b>73</b>
2.2	05.1989 → 06.1994	J7T 780	B	<b>95</b>	2.5 dCi	08.2007 →	G9U 630	D	<b>96</b>
2.2	06.1994 → 10.1997	J7T 600	B	<b>95</b>	2.5 dCi 135 (FLOD)	05.2003 →	G9U 730	D	<b>96</b>
2.2 4x4	05.1989 → 06.1994	J7T 780	B	<b>95</b>	2.5 dCi 145 (FLOJ)	08.2006 →	G9U 630	D	<b>96</b>
2.2 4x4	06.1994 → 10.1997	J7T 600	B	<b>95</b>	<b>TRAFIC III Bus (JG_)</b>				
2.5 D	05.1989 → 08.1994	S8U 750	D	<b>99</b>	1.6 dCi 115 (JGMD)	05.2014 →	R9M 408	D	<b>53</b>
2.5 D	05.1989 → 03.2001	8140.67.2500	D	<b>102</b>	1.6 dCi 120 (JGMB)	05.2014 →	R9M 450	D	<b>53</b>
2.5 D	05.1989 → 03.2001	8140.67.2550	D	<b>102</b>	1.6 dCi 125 (JGMH)	07.2015 →	R9M 452	D	<b>53</b>
2.5 D	05.1989 → 03.2001	8140.67.2580	D	<b>102</b>	1.6 dCi 140 (JGMA)	05.2014 →	R9M 450	D	<b>53</b>
2.5 D	05.1989 → 03.2001	S8U 750	D	<b>99</b>	1.6 dCi 145 (JGMG)	07.2015 →	R9M 452	D	<b>53</b>
2.5 D	05.1989 → 03.2001	S8U 752	D	<b>99</b>	1.6 dCi 90 (JGME)	05.2014 →	R9M 408	D	<b>53</b>
2.5 D	05.1989 → 03.2001	S8U 758	D	<b>99</b>	1.6 dCi 95 (JGMR, JGMJ)	07.2015 →	R9M 413	D	<b>53</b>
2.5 D	09.1994 → 04.1998	S8U 758	D	<b>99</b>	<b>TRAFIC III Platform/Chassis (EG_)</b>				
2.5 D 4x4	08.1989 → 03.2001	8140.67.2500	D	<b>102</b>	1.6 dCi 120 (EGMB)	06.2014 →	R9M 450	D	<b>53</b>
2.5 D 4x4	08.1989 → 03.2001	8140.67.2550	D	<b>102</b>	1.6 dCi 125 (EGMH)	07.2015 →	R9M 452	D	<b>53</b>
2.5 D 4x4	08.1989 → 03.2001	8140.67.2580	D	<b>102</b>	1.6 dCi 140 (EGMA)	06.2014 →	R9M 450	D	<b>53</b>
2.5 D 4x4	08.1989 → 03.2001	S8U 750	D	<b>99</b>	1.6 dCi 145 (EGMG)	07.2015 →	R9M 452	D	<b>53</b>
2.5 D 4x4	08.1989 → 03.2001	S8U 752	D	<b>99</b>					

R

				Pos					Pos
<b>TRAFIC III Van (FG_)</b>					2.2 4x4	05.1989 → 06.1994	J7T 780	B	95
1.6 dCi 115 (FGMD)	05.2014 →	R9M 408	D	53	2.2 4x4	06.1994 → 10.1997	J7T 600	B	95
1.6 dCi 120 (FGMB)	05.2014 →	R9M 450	D	53	2.5 D	03.1989 → 08.1994	S8U 750	D	99
1.6 dCi 120 (FGMK)	07.2015 →	R9M 413	D	53	2.5 D	05.1989 → 03.2001	8140.67.2500	D	102
1.6 dCi 125 (FGMH)	07.2015 →	R9M 452	D	53	2.5 D	05.1989 → 03.2001	8140.67.2550	D	102
1.6 dCi 140 (FGMA)	05.2014 →	R9M 450	D	53	2.5 D	05.1989 → 03.2001	8140.67.2580	D	102
1.6 dCi 145 (FGMG)	07.2015 →	R9M 452	D	53	2.5 D	05.1989 → 03.2001	S8U 750	D	99
1.6 dCi 90 (FGME)	05.2014 →	R9M 408	D	53	2.5 D	05.1989 → 03.2001	S8U 752	D	99
1.6 dCi 95 (FGMJ, FGMR)	07.2015 →	R9M 413	D	53	2.5 D	05.1989 → 03.2001	S8U 758	D	99
<b>TRAFIC Platform/Chassis (P6)</b>					2.5 D 4x4	05.1989 → 03.2001	8140.67.2500	D	102
1.4	03.1980 → 04.1989	847 700	B	17	2.5 D 4x4	05.1989 → 03.2001	8140.67.2580	D	99
1.4	03.1980 → 04.1989	C1J 700	B	17	2.5 D 4x4	05.1989 → 03.2001	S8U 750	D	99
1.7	06.1986 → 04.1989	F1N 722	B	56	2.5 D 4x4	05.1989 → 03.2001	S8U 752	D	99
2.0	03.1980 → 04.1989	J5R 726	B	95	<b>TWINGO I Hatchback Van (S06_)</b>				
2.0 4x4	05.1985 → 02.1989	J5R 716	B	95	1.2	03.1997 → 08.2003	D7F 700	B	4
2.1 D	03.1980 → 04.1989	852 720	D	89	1.2	03.1997 → 08.2003	D7F 701	B	4
2.1 D	07.1980 → 04.1985	852 750	D	89	1.2	01.2001 → 06.2012	D4F 702	B	5
2.1 D 4x4	05.1985 → 02.1989	852 750	D	89	1.2 (S063, S064)	03.1993 → 05.1996	C3G 700	B	14
2.5 D	03.1980 → 04.1989	8140.61.240	D	98	1.2 (S063, S064)	10.1994 → 05.1996	C3G 702	B	14
2.5 D	12.1982 → 04.1989	S8U 720	D	99	1.2 (S066, S068)	05.1996 → 08.2004	D7F 700	B	4
2.5 D	12.1982 → 04.1989	S8U 722	D	99	1.2 (S066, S068)	05.1996 → 08.2004	D7F 701	B	4
<b>TRAFIC Platform/Chassis (PXX)</b>					1.2 (S066, S068)	05.1996 → 08.2004	D7F 703	B	4
1.7	05.1989 → 08.1994	F1N 722	B	56	1.2 (S066, S068)	05.1996 → 08.2004	D7F 704	B	4
2.0 RWD	05.1989 → 10.1997	J5R 726	B	95	1.2 (S066, S068)	05.1996 → 08.2004	D7F 706	B	4
2.1 D	09.1994 → 04.1998	J8S 620	D	89	<b>TWINGO II Hatchback Van (CNO_)</b>				
2.1 D RWD	05.1989 → 06.1994	852 720	D	89	1.2 (CN01, CN06)	09.2010 → 09.2014	D4F 770	B	5
2.1 D RWD	06.1994 → 10.1997	J8S 620	D	89	1.5 dCi (CN03)	10.2010 → 09.2014	K9K 820	D	21
2.1 D RWD	06.1994 → 10.1997	J8S 758	D	89					
2.2	05.1989 → 06.1994	J7T 780	B	95	<b>TRACTOR</b>				
2.2	09.1994 → 04.1998	J7T 600	B	95	106	01.1970 →	D 227-6	D	113
2.2 4x4	09.1994 → 04.1998	J7T 600	B	95	110	01.1969 →	D 226-6	D	117
2.5 D	05.1989 → 08.1994	S8U 750	D	99	1451-4	01.1976 → 03.1981	TD 228-6	D	120
2.5 D	05.1989 → 03.2001	8140.61.240	D	98	32-50	01.1970 →	D 327-3	D	113
2.5 D	05.1989 → 03.2001	S8U 720	D	99	32-60	01.1970 →	D 327-3	D	113
2.5 D	05.1989 → 03.2001	S8U 722	D	99	42-70	01.1970 →	D 327-4	D	113
2.5 D	09.1994 → 04.1998	S8U 758	D	99	421	01.1970 →	D 327-3	D	113
2.5 D	05.1998 → 03.2001	S8U 758	D	99	461	01.1970 → 1977	D 227-4	D	113
2.5 D	05.1998 → 03.2001	S8U 780	D	99	461	01.1970 →	D 327-3	D	113
2.5 D 4x4	05.1989 → 08.1994	S8U 750	D	99	489	01.1968 → 12.1988	D 226-3	D	117
<b>TRAFIC Van (T1, T3, T4, T2)</b>					496	01.1968 → 12.1988	D 226-4	D	117
1.4	03.1980 → 04.1989	847 700	B	17	50	01.1969 → 1981	D 325-2	D	108
1.4	03.1980 → 04.1989	847 701	B	17	50 S	01.1972 → 1977	D 327-2	D	113
1.4	03.1980 → 04.1989	C1J 700	B	17	51	01.1969 → 1981	D 225-2	D	108
1.7	06.1986 → 04.1989	F1N 724	B	56	51	01.1969 → 1981	D 225-3	D	109
2.0	05.1985 → 02.1989	J5R 716	B	95	551	01.1968 → 12.1988	D 226-3	D	117
2.0	06.1986 → 04.1989	J5R 716	B	95	556	01.1968 → 12.1988	D 226-3	D	117
2.0	06.1986 → 04.1989	J5R 722	B	95	56	01.1969 → 1981	D 325-3	D	108
2.0	06.1986 → 04.1989	J5R 726	B	95	61	01.1969 →	D 226-3	D	117
2.0 4x4	06.1986 → 04.1989	J5R 716	B	95	65	01.1970 → 1977	D 227-4	D	113
2.0 4x4	06.1986 → 04.1989	J5R 722	B	95	68	01.1970 → 1977	D 227-4	D	113
2.0 4x4	06.1986 → 04.1989	J5R 726	B	95	681	01.1970 → 1977	D 227-4	D	113
2.1 D	09.1980 → 04.1989	852 750	D	89	70		A 4.236	D	112
2.1 D	05.1986 → 02.1989	852 750	D	89	75	01.1969 →	D 226-4	D	117
2.1 D 4x4	11.1986 → 04.1989	852 750	D	89	751	01.1968 → 12.1988	D 226-4	D	117
<b>TRAFIC Van (TXX)</b>					752	01.1968 → 12.1988	D 226-4	D	117
1.4	05.1989 → 06.1991	C1J 700	B	17	77	01.1969 →	D 226-4	D	117
1.4	07.1989 → 08.1992	C1J 768	B	17	781	01.1968 → 12.1988	D 226-4	D	117
1.7	03.1989 → 08.1994	F1N 724	B	56	80	01.1969 →	D 226-4	D	117
1.7	08.1992 → 08.1994	F1N 720	B	56	80	01.1972 → 1977	D 327-3	D	113
1.9 D	06.1997 → 01.1999	F8Q 606	D	42	85	01.1969 →	D 226-4	D	117
2.0	05.1989 → 08.1990	J5R 716	B	95	90	01.1970 → 1977	D 327-4	D	113
2.0	06.1999 → 12.2001	J5R 716	B	95	921	01.1970 → 1977	D 227-6	D	113
2.1 D	05.1989 → 06.1994	852 750	D	89	94	01.1969 → 1981	D 325-4	D	108
2.1 D	06.1994 → 10.1997	J8S 620	D	89	D 22	01.1960 → 1965	AKD 112-2	D	110
2.1 D	06.1994 → 10.1997	J8S 758	D	89	D 22	01.1960 → 1965	AKD 112-3	D	110
2.2	05.1989 → 06.1994	J7T 780	B	95	MX 58	01.1969 →	D 226-3	D	117
2.2	06.1994 → 10.1997	J7T 600	B	95	MX 65	01.1969 →	D 226-3	D	117
2.2	01.1995 → 05.1999	J7T 600	B	95					



			Pos				Pos
MX 75	01.1969 →	D 226-4	D				
MX 85	01.1969 →	D 226-4	D				
MX 90	01.1969 →	D 226-4	D				
TS 110	01.1969 →	D 226-6	D				
TX 103	01.1969 →	TD 226-4	D				
TX 113	1977 →	D 227-6	D				
TX 120	01.1969 →	D 226-6	D				
TX 133	01.1969 →	D 226-6	D				
TX 145	01.1976 →	TD 228-6	D				
TX 155	01.1969 →	TD 226 B-6	D				
TX 80	01.1969 →	D 226-4	D				
TX 85	01.1969 →	D 226-4	D				
TX 90	01.1969 →	D 226-4	D				
TX 95	01.1969 →	D 226-4	D				
TZ 120	01.1969 →	D 226-6	D				
TZ 133	01.1969 →	D 226-6	D				
TZ 145	01.1976 →	TD 228-6	D				
TZ 155	01.1969 →	TD 226 B-6	D				

R

					Reference	Item No.	
<b>1</b>		<b>61,4</b>					
<b>813.02</b>		B (NA)	4	852 cm <sup>3</sup> 2V	21 kW (29 PS)	8:1 72,00 mm	
	[50] [50]	∅ 7 mm ∅ 7 mm				77 00 725 145 08 54 895 300	<b>KK-7H</b> <b>MK-7H2</b>
	IN/EX [4]	11,14 x 7 x 41,5	G1			00 03 102 891 07 10 939 000	<b>81-5115</b>
<b>2</b>		<b>65</b>					
<b>689.01</b>		B (NA)	4	956 cm <sup>3</sup> 2V	29 kW (39 PS)	8,5:1 72,00 mm	
<b>689.10</b>		B (NA)	4	956 cm <sup>3</sup> 2V	31-33 kW (42-45 PS)	9,25:1 72,00 mm	
<b>C1C</b>		<b>706, 754</b>					
		09.1985 → 05.1992	B (NA)	4	956 cm <sup>3</sup> 2V	24-31 kW (33-42 PS)	8,6:1 72,00 mm
	[50] [50]	∅ 7 mm ∅ 7 mm				77 00 725 145 08 54 895 300	<b>KK-7H</b> <b>MK-7H2</b>
	IN/EX [4]	11,14 x 7 x 41,5	G1			00 03 102 891 07 10 939 000	<b>81-5115</b>
<b>3</b>		<b>69</b>					
<b>D4F</b>		<b>740, 744</b>					
		12.2004 →	BG (NA)	4	1149 cm <sup>3</sup> 4V	48-55 kW (65-75 PS)	9,8 76,80 mm
40 219 6..							
	IN [2]	26,0 x 5,5 x 110,8	S - -	- 45° - -	22 - III	77 01 472 986 82 00 343 407	<b>539028</b>
	EX [2]	22,1 x 5,5 x 112,5	RA/S- -	- 45° - -	22 - III	77 01 473 004 82 00 343 412	<b>539029</b>
	[50]	∅ 5,5 mm					<b>MK-5.5H</b>
	IN/EX [4]	11,07 x 5,5 x 40,6	B1			77 00 109 151	<b>81-5136</b> (1)
		(1) ohne Ventilschaftabdichtung/without valve stem gasket/sans joint de tige de soupape/sin junta de vástago de válvula/без уплотнения стержня клапана					
<b>4</b>		<b>69</b>					
<b>D7F Euro 4</b>		<b>766</b>					
		07.1998 → 06.2009	B (NA)	4	1149 cm <sup>3</sup> 2V	43 kW (58 PS)	9,6 76,80 mm
<b>D7F</b>		<b>700, 701, 702, 703, 704, 706, 708, 710, 720, 722, 726, 730, 744, 746, 764, 800</b>					
		01.1996 →	B (NA)	4	1149 cm <sup>3</sup> 2V	40-44 kW (54-60 PS)	76,80 mm
99 646 6..							
	IN [2]	32,8 x 6 x 106,7	S - -	- 30° - -	1 - III	77 01 469 266	<b>511019</b>
	EX [2]	29,9 x 6 x 106,7	A/S - -	- 45° - -	1 - III	77 01 469 269	<b>511020</b>
	IN/EX [4]	11,07 x 6 x 45,0	B1				<b>81-5132</b>

R

					Reference	Item No.
<b>5</b>		<b>69</b>				
<b>D4D</b>	<b>706</b>					
	06.2001 → 11.2004	B	4	999 cm <sup>3</sup>	4V	44 kW (60 PS) 9,6:1 66,80 mm
<b>D4D</b>	<b>700, 712, 720, 754</b>					
	06.2000 →	B (NA)	4	999 cm <sup>3</sup>	4V	44-59 kW (60-80 PS) 9,8 66,80 mm
<b>D4D</b>	<b>752</b>					
	06.2001 → 11.2004	B	4	999 cm <sup>3</sup>	4V	44 kW (60 PS) 9,6:1 76,80 mm
<b>D4F</b>	<b>780</b>					
	06.2005 →	B (LA)	4	1149 cm <sup>3</sup>	4V	74-75 kW (100-102 PS) 9,5 76,80 mm
<b>D4F</b>	<b>44 kW, 48 kW, 726</b>					
		B	4	1149 cm <sup>3</sup>	4V	44-55 kW (60-75 PS) 76,80 mm
<b>D4F Euro 3</b>	<b>708</b>					
	08.2004 → 06.2007	B (NA)	4	1149 cm <sup>3</sup>	4V	44 kW (60 PS) 9,8 76,80 mm
<b>D4F Euro 5</b>	<b>782</b>					
	03.2007 →	B (LA)	4	1149 cm <sup>3</sup>	4V	74-75 kW (101-102 PS) 9,5 76,80 mm
<b>D4F</b>	<b>702, 706, 712, 714, 716, 722, 728, 730, 732, 734, 764, 770, 772, 784, 786, 790</b>					
		B (NA)	4	1149 cm <sup>3</sup>	4V	43-76 kW (58-103 PS) 76,80 mm
40 219 6..						
	IN [2]	26,0 x 5,5 x 110,8	S - -	- 45° - -	22 - III	77 01 472 986 82 00 343 407 <b>539028</b>
	EX [2]	22,1 x 5,5 x 112,5	RA/S- -	- 45° - -	22 - III	77 01 473 004 82 00 343 412 <b>539029</b>
	[50]	Ø 5,5 mm				<b>MK-5.5H</b>
	IN/EX [4]	11,07 x 5.5 x 40,6	B1			77 00 109 151 <b>81-5136</b> (1)
	(1) ohne Ventilschaftabdichtung/without valve stem gasket/sans joint de tige de soupape/sin junta de vástago de válvula/без уплотнения стержня клапана					
<b>6</b>		<b>69</b>				
<b>D4F</b>	<b>742</b>					
	11.2007 → 12.2012	AB (NA)	4	1149 cm <sup>3</sup>	4V	55-58 kW (75-79 PS) 9,8 76,80 mm
	IN [2]	26,0 x 5,5 x 110,8	S - -	- 45° - -	22 - III	77 01 472 986 82 00 343 407 <b>539028</b>
	EX [2]	22,1 x 5,5 x 112,5	RA/S- -	- 45° - -	22 - III	77 01 473 004 82 00 343 412 <b>539029</b>
	[50]	Ø 5,5 mm				<b>MK-5.5H</b>
	IN/EX [4]	11,07 x 5.5 x 40,6	B1			77 00 109 151 <b>81-5136</b> (1)
	(1) ohne Ventilschaftabdichtung/without valve stem gasket/sans joint de tige de soupape/sin junta de vástago de válvula/без уплотнения стержня клапана					
<b>7</b>		<b>70</b>				
<b>688</b>	<b>02, 13</b>					
	09.1980 →	B (NA)	4	1108 cm <sup>3</sup>	2V	33-41 kW (45-56 PS) 72,00 mm
<b>688.01</b>						
	02.1962 → 12.1981	B (NA)	4	1108 cm <sup>3</sup>	2V	25-39 kW (34-53 PS) 9 72,00 mm
<b>688.06</b>						
		B (NA)	4	1108 cm <sup>3</sup>	2V	26 kW (35 PS) 9,5:1 72,00 mm
<b>688.09</b>						
		B (NA)	4	1108 cm <sup>3</sup>	2V	26 kW (35 PS) 9,5:1 72,00 mm
<b>688.10</b>						
	08.1970 → 04.1987	B (NA)	4	1108 cm <sup>3</sup>	2V	25-39 kW (34-53 PS) 9,5 72,00 mm
<b>688.11</b>						
		B (NA)	4	1108 cm <sup>3</sup>	2V	25-39 kW (34-53 PS) 8,3-9,5 72,00 mm
<b>C1E</b>	<b>688, 700, 714, 715, 718, 719, 720, 726, 750, 752, 754, 756, 760, 762, 764, 792</b>					
	10.1976 → 09.1998	B (NA)	4	1108 cm <sup>3</sup>	2V	25-36 kW (34-49 PS) 72,00 mm
Fortsetzung nächste Seite / continued on next page / suite page suivante / continuación página próxima / Продолжение на следующей странице						

**R**

					Reference	Item No.
[50] [50]	∅ 7 mm ∅ 7 mm				77 00 725 145 08 54 895 300	<b>KK-7H</b> <b>MK-7H2</b>
IN/EX [4]	11,14 x 7 x 41,5	G1			00 03 102 891 07 10 939 000	<b>81-5115</b>

<b>8</b> <b>71,5</b> <b>C1G</b> <b>700, 702, 710, 720, 722, 726, 730</b> 10.1984 → 12.1996 B (NA) 4    1237 cm <sup>3</sup> 2V    40-44 kW    (54-60 PS) 9,25    77,00 mm						
[50] [50]	∅ 7 mm ∅ 7 mm				77 00 725 145 08 54 895 300	<b>KK-7H</b> <b>MK-7H2</b>
IN/EX [4]	11,14 x 7 x 41,5	G1			00 03 102 891 07 10 939 000	<b>81-5115</b>

<b>9</b> <b>72,2</b> <b>H4B</b> <b>451</b> 08.2018 →    BG (A)    3    898 cm <sup>3</sup> 4V    66 kW    (90 PS)    73,10 mm						
[4]	M	30 x 28			13 23 110 18R	<b>50 007 814</b>
[4]	M	30 x 28			13 23 110 55R	<b>50 007 815</b>
[4]	M	30 x 28			13 23 100 94R	<b>50 007 816</b>
[4]	M	30 x 28			13 23 103 50R	<b>50 007 818</b>
[4]	M	30 x 28			13 23 103 55R	<b>50 007 819</b>
[4]	M	30 x 28			13 23 104 01R	<b>50 007 820</b>
[4]	M	30 x 28			13 23 105 14R	<b>50 007 821</b>
[4]	M	30 x 28			13 23 105 73R	<b>50 007 822</b>
[4]	M	30 x 28			13 23 107 66R	<b>50 007 823</b>
[4]	M	30 x 28			13 23 110 28R	<b>50 007 824</b>
[4]	M	30 x 28			13 23 114 44R	<b>50 007 825</b>
[4]	M	30 x 28			13 23 119 89R	<b>50 007 826</b>
[4]	M	30 x 28			13 23 125 91R	<b>50 007 827</b>
[4]	M	30 x 28			13 23 144 87R	<b>50 007 828</b>
[4]	M	30 x 28			13 23 144 88R	<b>50 007 830</b>
[4]	M	30 x 28			13 23 145 63R	<b>50 007 831</b>
[4]	M	30 x 28			13 23 157 48R	<b>50 007 832</b>
[4]	M	30 x 28			13 23 159 24R	<b>50 007 833</b>
[4]	M	30 x 28			13 23 162 45R	<b>50 007 834</b>
[4]	M	30 x 28			13 23 165 09R	<b>50 007 835</b>
[4]	M	30 x 28			13 23 168 83R	<b>50 007 836</b>
[4]	M	30 x 28			13 23 169 19R	<b>50 007 838</b>
[4]	M	30 x 28			13 23 170 88R	<b>50 007 839</b>
[4]	M	30 x 28			13 23 171 11R	<b>50 007 840</b>
[4]	M	30 x 28			13 23 171 31R	<b>50 007 841</b>
[4]	M	30 x 28			13 23 184 83R	<b>50 007 842</b>
[4]	M	30 x 28			13 23 188 43R	<b>50 007 843</b>
[4]	M	30 x 28			13 23 196 49R	<b>50 007 844</b>
[4]	M	30 x 28			13 23 153 87R	<b>50 007 845</b>
[4]	M	30 x 28			13 23 183 35R	<b>50 007 846</b>
[4]	M	30 x 28			13 23 187 70R	<b>50 007 847</b>

<b>10</b> <b>72,2</b> <b>H5F Filter</b> <b>400, 403, 404, 408, 412</b> 03.2012 →    B (A)    4    1197 cm <sup>3</sup> 4V    74-97 kW    (101-132 PS) 10    73,10 mm						
IN [2]	26,6 x 5,5 x 100,8	S - Ni -	- 45° - -	22 - III	13 20 135 62R 13 20 173 22R	<b>539048</b> <small>NEW</small>
EX [2]	23,5 x 5,5 x 101,7	RA/S- -	- 30° - -	22 - III	13 20 253 79R 13 20 272 23R	<b>539052</b> <small>NEW</small>

Fortsetzung nächste Seite / continued on next page / suite page suivante / continuación página próxima / Продолжение на следующей странице

					Reference	Item No.
[50]	Ø 5,5 mm					MK-5.5H
<b>11</b>	<b>72,2</b>					
<b>H4B</b>	<b>400, 401, 408</b> 11.2012 →	B (A) 3	898 cm <sup>3</sup> 4V	56-80 kW	(76-109 PS) 9,5	73,10 mm
IN [2]	26,6 x 5,5 x 100,8	S - Ni -	- 45° - -	22 - III	13 20 135 62R 13 20 173 22R	<b>539048</b>
EX [2]	23,5 x 5,5 x 101,7	RA/S- -	- 30° - -	22 - III	13 20 253 79R 13 20 272 23R	<b>539052</b>
[50]	Ø 5,5 mm					MK-5.5H
	[4] M 30 x 28				13 23 110 18R	<b>50 007 814</b>
	[4] M 30 x 28				13 23 110 55R	<b>50 007 815</b>
	[4] M 30 x 28				13 23 100 94R	<b>50 007 816</b>
	[4] M 30 x 28				13 23 103 50R	<b>50 007 818</b>
	[4] M 30 x 28				13 23 103 55R	<b>50 007 819</b>
	[4] M 30 x 28				13 23 104 01R	<b>50 007 820</b>
	[4] M 30 x 28				13 23 105 14R	<b>50 007 821</b>
	[4] M 30 x 28				13 23 105 73R	<b>50 007 822</b>
	[4] M 30 x 28				13 23 107 66R	<b>50 007 823</b>
	[4] M 30 x 28				13 23 110 28R	<b>50 007 824</b>
	[4] M 30 x 28				13 23 114 44R	<b>50 007 825</b>
	[4] M 30 x 28				13 23 119 89R	<b>50 007 826</b>
	[4] M 30 x 28				13 23 125 91R	<b>50 007 827</b>
	[4] M 30 x 28				13 23 144 87R	<b>50 007 828</b>
	[4] M 30 x 28				13 23 144 88R	<b>50 007 830</b>
	[4] M 30 x 28				13 23 145 63R	<b>50 007 831</b>
	[4] M 30 x 28				13 23 157 48R	<b>50 007 832</b>
	[4] M 30 x 28				13 23 159 24R	<b>50 007 833</b>
	[4] M 30 x 28				13 23 162 45R	<b>50 007 834</b>
	[4] M 30 x 28				13 23 165 09R	<b>50 007 835</b>
	[4] M 30 x 28				13 23 168 83R	<b>50 007 836</b>
	[4] M 30 x 28				13 23 169 19R	<b>50 007 838</b>
	[4] M 30 x 28				13 23 170 88R	<b>50 007 839</b>
	[4] M 30 x 28				13 23 171 11R	<b>50 007 840</b>
	[4] M 30 x 28				13 23 171 31R	<b>50 007 841</b>
	[4] M 30 x 28				13 23 184 83R	<b>50 007 842</b>
	[4] M 30 x 28				13 23 188 43R	<b>50 007 843</b>
	[4] M 30 x 28				13 23 196 49R	<b>50 007 844</b>
	[4] M 30 x 28				13 23 153 87R	<b>50 007 845</b>
	[4] M 30 x 28				13 23 183 35R	<b>50 007 846</b>
	[4] M 30 x 28				13 23 187 70R	<b>50 007 847</b>
<b>12</b>	<b>72,2</b>					
<b>H4B</b>	<b>410, 453</b> 08.2015 →	B (A) 3	898 cm <sup>3</sup> 4V	66-68 kW	(90-92 PS)	73,10 mm
Fortsetzung nächste Seite / continued on next page / suite page suivante / continuación página próxima / Продолжение на следующей странице						

**R**

					Reference	Item No.
	[4] M 30 x 28				13 23 110 18R	<b>50 007 814</b>
	[4] M 30 x 28				13 23 110 55R	<b>50 007 815</b>
	[4] M 30 x 28				13 23 100 94R	<b>50 007 816</b>
	[4] M 30 x 28				13 23 103 50R	<b>50 007 818</b>
	[4] M 30 x 28				13 23 103 55R	<b>50 007 819</b>
	[4] M 30 x 28				13 23 104 01R	<b>50 007 820</b>
	[4] M 30 x 28				13 23 105 14R	<b>50 007 821</b>
	[4] M 30 x 28				13 23 105 73R	<b>50 007 822</b>
	[4] M 30 x 28				13 23 107 66R	<b>50 007 823</b>
	[4] M 30 x 28				13 23 110 28R	<b>50 007 824</b>
	[4] M 30 x 28				13 23 114 44R	<b>50 007 825</b>
	[4] M 30 x 28				13 23 119 89R	<b>50 007 826</b>
	[4] M 30 x 28				13 23 125 91R	<b>50 007 827</b>
	[4] M 30 x 28				13 23 144 87R	<b>50 007 828</b>
	[4] M 30 x 28				13 23 144 88R	<b>50 007 830</b>
	[4] M 30 x 28				13 23 145 63R	<b>50 007 831</b>
	[4] M 30 x 28				13 23 157 48R	<b>50 007 832</b>
	[4] M 30 x 28				13 23 159 24R	<b>50 007 833</b>
	[4] M 30 x 28				13 23 162 45R	<b>50 007 834</b>
	[4] M 30 x 28				13 23 165 09R	<b>50 007 835</b>
	[4] M 30 x 28				13 23 168 83R	<b>50 007 836</b>
	[4] M 30 x 28				13 23 169 19R	<b>50 007 838</b>
	[4] M 30 x 28				13 23 170 88R	<b>50 007 839</b>
	[4] M 30 x 28				13 23 171 11R	<b>50 007 840</b>
	[4] M 30 x 28				13 23 171 31R	<b>50 007 841</b>
	[4] M 30 x 28				13 23 184 83R	<b>50 007 842</b>
	[4] M 30 x 28				13 23 188 43R	<b>50 007 843</b>
	[4] M 30 x 28				13 23 196 49R	<b>50 007 844</b>
	[4] M 30 x 28				13 23 153 87R	<b>50 007 845</b>
	[4] M 30 x 28				13 23 183 35R	<b>50 007 846</b>
	[4] M 30 x 28				13 23 187 70R	<b>50 007 847</b>

## 13 73

<b>810</b>	<b>719, 725, 726, 729</b>								
	09.1975 → 09.1984	B	(NA)	4	1289 cm <sup>3</sup>	2V	31-47 kW	(42-64 PS)	77,00 mm
<b>810-02/97</b>	01.1970 → 04.1980	B	(NA)	4	1289 cm <sup>3</sup>	2V	40 kW	(54 PS) 8,5	77,00 mm
<b>810.01</b>	08.1969 → 12.1981	B	(NA)	4	1289 cm <sup>3</sup>	2V	26-32 kW	(37-44 PS) 8,5	77,00 mm
<b>810.02</b>	07.1975 → 04.1980	B	(NA)	4	1289 cm <sup>3</sup>	2V	37 kW	(50 PS) 8,5	77,00 mm
<b>810.03</b>	07.1969 → 10.1972	B	(NA)	4	1289 cm <sup>3</sup>	2V	35 kW	(48 PS) 8,5	77,00 mm
<b>810.05</b>	03.1972 → 10.1980	B	(NA)	4	1289 cm <sup>3</sup>	2V	31-45 kW	(42-61 PS) 9,5	77,00 mm
<b>810.06</b>	08.1972 → 03.1983	B	(NA)	4	1289 cm <sup>3</sup>	2V	44 kW	(60 PS) 9,5	77,00 mm
<b>810.10</b>	01.1972 →	B	(NA)	4	1289 cm <sup>3</sup>	2V	44 kW	(60 PS) 9,5:1	77,00 mm
<b>810.19</b>	10.1980 → 08.1981	B	(NA)	4	1289 cm <sup>3</sup>	2V	33 kW	(45 PS) 8,2:1	77,00 mm
<b>810.25</b>		B	(NA)	4	1289 cm <sup>3</sup>	2V	31-50 kW	(42-68 PS) 9,5:1	77,00 mm
<b>810.26</b>		B	(NA)	4	1289 cm <sup>3</sup>	2V	31-50 kW	(42-68 PS) 9,5:1	77,00 mm
<b>810.29</b>		B	(NA)	4	1289 cm <sup>3</sup>	2V	40 kW	(54 PS) 9,6:1	77,00 mm

	[50] Ø 7 mm					77 00 725 145	<b>KK-7H</b>
	[50] Ø 7 mm					08 54 895 300	<b>MK-7H2</b>
	IN/EX [4] 11,14 x 7 x 41,5	G1				00 03 102 891	<b>81-5115</b>
						07 10 939 000	



					Reference	Item No.	
<b>14</b>		<b>74</b>					
<b>C3G</b>	<b>700, 702, 710, 712, 720, 750</b>						
	09.1991 →	B (NA)	4	1239 cm <sup>3</sup>	2V	40 kW (54-55 PS)	72,00 mm
	[50]	∅ 7 mm				77 00 725 145	<b>KK-7H</b>
	[50]	∅ 7 mm				08 54 895 300	
	IN/EX [4]	11,14 x 7 x 41,5	G1			00 03 102 891	<b>81-5115</b>
						07 10 939 000	
<b>15</b>		<b>75,8</b>					
<b>C3J</b>	<b>710, 760</b>						
	10.1985 → 12.1995	B (NA)	4	1390 cm <sup>3</sup>	2V	43-44 kW (58-60 PS)	77,00 mm
<b>C3J</b>	<b>762</b>						
	09.1991 → 03.1998	B (NA)	4	1390 cm <sup>3</sup>	2V	43-44 kW (58-60 PS) 9	77,00 mm
	[50]	∅ 7 mm				77 00 725 145	<b>KK-7H</b>
	[50]	∅ 7 mm				08 54 895 300	
	IN/EX [4]	11,14 x 7 x 41,5	G1			00 03 102 891	<b>81-5115</b>
						07 10 939 000	
<b>16</b>		<b>75,8</b>					
<b>E5F</b>	<b>710</b>						
	05.1990 → 09.1998	B (NA)	4	1171 cm <sup>3</sup>	2V	40-44 kW (55-60 PS) 8,8	64,90 mm
<b>E5F</b>	<b>716</b>						
		B	4	1171 cm <sup>3</sup>	2V	40-44 kW (55-60 PS) 8,8:1	64,90 mm
<b>E6J</b>	<b>712, 713, 718, 738</b>						
	03.1986 → 09.1998	B (NA)	4	1390 cm <sup>3</sup>	2V	43-57 kW (60-80 PS)	77,00 mm
<b>E6J</b>	<b>700, 701, 706, 734, 760</b>						
	03.1986 → 06.2001	B (NA)	4	1390 cm <sup>3</sup>	2V	43-60 kW (60-82 PS) 9,5	77,00 mm
<b>E7F</b>	<b>700, 704, 706, 730</b>						
	05.1990 →	B (NA)	4	1171 cm <sup>3</sup>	2V	40-46 kW (54-63 PS)	64,90 mm
<b>E7F</b>	<b>708, 750</b>						
	05.1990 → 09.1998	B (NA)	4	1171 cm <sup>3</sup>	2V	43-48 kW (58-65 PS)	64,90 mm
<b>E7J</b>	<b>626, 720, 724, 728, 742, 780</b>						
	09.1991 →	B (NA)	4	1390 cm <sup>3</sup>	2V	43-59 kW (58-80 PS) 9,5	77,00 mm
<b>E7J</b>	<b>601, 624, 634, 635, 700, 706, 707, 710, 711, 718, 719, 726, 745, 754, 756, 757, 764, 770, 771, 773</b>						
	09.1990 →	B (NA)	4	1390 cm <sup>3</sup>	2V	52-59 kW (71-80 PS)	77,00 mm
<b>K7J</b>	<b>700, 701</b>						
	08.1997 →	B (NA)	4	1390 cm <sup>3</sup>	2V	55-72 kW (75-98 PS) 9,5	77,00 mm
	IN [2]	37,6 x 7 x 107,7	S - -	- 30° - -	1 - III	60 01 548 030	<b>511017</b>
						77 00 273 371	
						77 00 273 373	
						77 00 853 390	
						77 01 465 088	
	EX [2]	33,6 x 7 x 107,7	A/S - -	- 45° - -	1 - III	60 01 548 029	<b>511018</b>
						77 00 865 832	
						77 00 865 934	
						77 01 465 090	
						77 01 468 419	
	[50]	∅ 7 mm				77 00 725 145	<b>KK-7H</b>
	IN [4]	12,06 x 7 x 42,0	B1				<b>81-5133</b>
	EX [4]	12,06 x 7 x 49,0	B1				

**R**

					Reference	Item No.
<b>17</b>	<b>76</b>					
<b>847</b>	<b>700, 701, 720, 722</b>					
	04.1978 → 10.1991 B (NA) 4 1397 cm <sup>3</sup> 2V 35-47 kW (48-64 PS) 77,00 mm					
<b>C1J</b>	<b>760, 764</b>					
	02.1984 → 12.1989 B (A) 4 1397 cm <sup>3</sup> 2V 69-87 kW (105-118 PS) 8,05 77,00 mm					
<b>C1J</b>	<b>700, 715, 742, 768, 780, 791, 792, 796</b>					
	08.1976 → 10.2000 B (NA) 4 1397 cm <sup>3</sup> 2V 35-53 kW (48-72 PS) 77,00 mm					
<b>C1J</b>	<b>770, 782, 784, 788</b>					
	07.1986 → 08.1990 B (LA) 4 1397 cm <sup>3</sup> 2V 85-88 kW (115-120 PS) 77,00 mm					
<b>C1J</b>	<b>798</b>					
	B 4 1397 cm <sup>3</sup> 2V 53 kW (72 PS) 9,25:1 77,00 mm					
<b>C2J</b>	<b>700, 713, 717, 718, 720, 730, 755, 757, 760, 766, 767, 768, 770, 772, 776, 780, 781, 782, 784, 788, 789, 792, 794, 796, 797, 798</b>					
	01.1982 → B (NA) 4 1397 cm <sup>3</sup> 2V 43-53 kW (58-72 PS) 77,00 mm					
<b>C3J</b>	<b>756</b>					
	B (NA) 4 1397 cm <sup>3</sup> 2V 43 kW (58 PS) 9:1 77,00 mm					
<b>C3J</b>	<b>700, 702</b>					
	09.1985 → 03.1998 B (NA) 4 1397 cm <sup>3</sup> 2V 43-44 kW (58-60 PS) 9 77,00 mm					
93 696 6..						
	[50] Ø 7 mm				77 00 725 145	<b>KK-7H</b>
	[50] Ø 7 mm				08 54 895 300	<b>MK-7H2</b>
	IN/EX [4] 11,14 x 7 x 41,5	G1			00 03 102 891	<b>81-5115</b>
					07 10 939 000	
<b>18</b>	<b>76</b>					
<b>K9K Euro 3</b>	<b>712</b>					
	10.2003 → 04.2005 D (A) 4 1461 cm <sup>3</sup> 2V 74 kW (100 PS) 18,8 80,50 mm					
<b>K9K</b>	<b>700, 702, 704, 710, 714, 722, 728, 729, 750</b>					
	D (A) 4 1461 cm <sup>3</sup> 2V 42-78 kW (57-106 PS) 80,50 mm					
40 190 6.., 40 465 6.., 41 068 6..						
	IN [2] 33,4 x 6 x 101,0	S - -	- 45° - -	22 - III	77 01 473 184	<b>539018</b>
	EX [2] 28,9 x 6 x 100,8	RA/S- -	- 45° - -	22 - III	77 01 476 573	<b>539017</b>
					77 01 473 183	
					77 01 476 572	
	[50] Ø 6 mm					<b>MK-6H</b>
	IN/EX [4] 11,05 x 6 x 40,5	B1				<b>81-51000</b> <small>NEW</small>
	IN/EX [4] 11,25/8.8 x 6 x 40,5	B1				<b>81-51001</b> <small>NEW</small>
					82 00 089 894	<b>50 006 314</b> (2)
					82 00 718 120	<b>50 007 017</b> <small>NEW</small> (1)
	(1) Schalenhartguss/chilled cast iron/pièce moulée trempée en surface/fundición en coquilla/Отливка с отбелсным поверхностным слоем / (ST)					
	(2) (ST)					
	[8] M 35 x 30 x 33 x 7,55				77 00 102 349	<b>50 007 540</b>
	[8] M 35 x 30 x 33 x 7,6				77 00 102 351	<b>50 007 541</b>
	[8] M 35 x 30 x 33 x 7,65				77 00 102 353	<b>50 007 542</b>
	[8] M 35 x 30 x 33 x 7,7				77 00 102 355	<b>50 007 543</b>
	[8] M 35 x 30 x 33 x 7,75				77 00 102 357	<b>50 007 544</b>
	[8] M 35 x 30 x 33 x 7,8				77 00 102 359	<b>50 007 545</b>
	[8] M 35 x 30 x 33 x 7,85				77 00 102 361	<b>50 007 546</b>
	[8] M 35 x 30 x 33 x 7,9				77 00 102 363	<b>50 007 547</b>
	[8] M 35 x 30 x 33 x 7,95				77 00 103 628	<b>50 007 548</b>
	[8] M 35 x 30 x 33 x 8				77 00 103 630	<b>50 007 549</b>

					Reference	Item No.	
<b>19</b>		<b>76</b>					
<b>K9K</b>	<b>706, 716, 724, 732, 734, 762, 764, 768, 800</b>						
			D (A)	4	1461 cm <sup>3</sup> 2V	45-78 kW (61-106 PS)	80,50 mm
<b>K9K Euro 4</b>	<b>780, 802, 804</b>						
	10.2007 →		D (A)	4	1461 cm <sup>3</sup> 2V	50-81 kW (68-110 PS)	15,6 80,50 mm
40 190 6.., 40 465 6.., 41 068 6.., 41 069 6..							
	IN [2]	33,4 x 6 x 101,0	S	- -	- 45° - -	22 - III	77 01 473 184 77 01 476 573 <b>539018</b>
	EX [2]	28,9 x 6 x 100,8	RA/S-	- -	- 45° - -	22 - III	77 01 473 183 77 01 476 572 <b>539017</b>
	[50]	Ø 6 mm					<b>MK-6H</b>
	IN/EX [4]	11,05 x 6 x 40,5	B1				<b>81-51000</b>
	IN/EX [4]	11,25/8.8 x 6 x 40,5	B1				<b>81-51001</b>
	[8]	M 35 x 30 x 33 x 7,55				77 00 102 349	<b>50 007 540</b>
	[8]	M 35 x 30 x 33 x 7,6				77 00 102 351	<b>50 007 541</b>
	[8]	M 35 x 30 x 33 x 7,65				77 00 102 353	<b>50 007 542</b>
	[8]	M 35 x 30 x 33 x 7,7				77 00 102 355	<b>50 007 543</b>
	[8]	M 35 x 30 x 33 x 7,75				77 00 102 357	<b>50 007 544</b>
	[8]	M 35 x 30 x 33 x 7,8				77 00 102 359	<b>50 007 545</b>
	[8]	M 35 x 30 x 33 x 7,85				77 00 102 361	<b>50 007 546</b>
	[8]	M 35 x 30 x 33 x 7,9				77 00 102 363	<b>50 007 547</b>
	[8]	M 35 x 30 x 33 x 7,95				77 00 103 628	<b>50 007 548</b>
	[8]	M 35 x 30 x 33 x 8				77 00 103 630	<b>50 007 549</b>
<b>20</b>		<b>76</b>					
<b>K9K</b>	<b>718</b>						
			D (A)	4	1461 cm <sup>3</sup> 2V	60-62 kW (82-84 PS)	18,8 80,50 mm
41 068 6..							
	IN [2]	33,4 x 6 x 101,0	S	- -	- 45° - -	22 - III	77 01 473 184 77 01 476 573 <b>539018</b>
	EX [2]	28,9 x 6 x 100,8	RA/S-	- -	- 45° - -	22 - III	77 01 473 183 77 01 476 572 <b>539017</b>
	[50]	Ø 6 mm					<b>MK-6H</b>
	IN/EX [4]	11,05 x 6 x 40,5	B1				<b>81-51000</b>
	IN/EX [4]	11,25/8.8 x 6 x 40,5	B1				<b>81-51001</b>
						82 00 718 120	<b>50 007 017</b> (1)
	(1) Schalenhartguss/chilled cast iron/pièce moulée trempée en surface/fundición en coquilla/Отливка с отбеленным поверхностным слоем / (ST)						
<b>21</b>		<b>76</b>					
<b>K9K Euro 5</b>	<b>636, 657, 816, 826, 837, 838, 884</b>						
	01.2009 →		D (A)	4	1461 cm <sup>3</sup> 2V	66-81 kW (90-110 PS)	80,50 mm
<b>K9K</b>	<b>260, 262, 272</b>						
			D (LA)	4	1461 cm <sup>3</sup> 2V	48 kW (65 PS)	18,8:1 80,50 mm
<b>K9K Euro 4</b>	<b>774, 806, 832</b>						
	06.2005 →		D (A)	4	1461 cm <sup>3</sup> 2V	76-78 kW (103-106 PS)	80,50 mm
<b>K9K Filter</b>	<b>629</b>						
	01.2013 →		D (A)	4	1461 cm <sup>3</sup> 2V	66 kW (90 PS)	15,5 80,50 mm
<b>K9K</b>	<b>500, 608, 609, 612, 628, 646, 647, 740, 760, 770, 772, 782, 808, 812, 820, 834, 836, 838, 840, 873</b>						
			D (A)	4	1461 cm <sup>3</sup> 2V	47-85 kW (64-116 PS)	80,50 mm
40 190 6.., 40 465 6.., 41 068 6.., 41 069 6.., 41 097 6.., 41 812 6.., 41 813 6..							
Fortsetzung nächste Seite / continued on next page / suite page suivante / continuación página próxima / Продолжение на следующей странице							

**R**

					Reference	Item No.
IN [2]	33,4 x 6 x 101,0	S - -	- 45° - -	22 - III	77 01 473 184 77 01 476 573	<b>539018</b>
EX [2]	28,9 x 6 x 100,8	RA/S- -	- 45° - -	22 - III	77 01 473 183 77 01 476 572	<b>539017</b>
[50]	Ø 6 mm					<b>MK-6H</b>
IN/EX [4]	11,05 x 6 x 40,5	B1				<b>81-51000</b> <small>NEW</small>
IN/EX [4]	11,25/8.8 x 6 x 40,5	B1				<b>81-51001</b> <small>NEW</small>

## 22 76

**K9K**
**752, 766**

12.2004 →

D (A)

4

 1461 cm<sup>3</sup> 2V

47-65 kW

(64-88 PS)

80,50 mm

40 190 6..., 40 465 6..., 41 068 6..

IN [2]	33,4 x 6 x 101,0	S - -	- 45° - -	22 - III	77 01 473 184 77 01 476 573	<b>539018</b>
EX [2]	28,9 x 6 x 100,8	RA/S- -	- 45° - -	22 - III	77 01 473 183 77 01 476 572	<b>539017</b>
[50]	Ø 6 mm					<b>MK-6H</b>
IN/EX [4]	11,05 x 6 x 40,5	B1				<b>81-51000</b> <small>NEW</small>
IN/EX [4]	11,25/8.8 x 6 x 40,5	B1				<b>81-51001</b> <small>NEW</small>
					82 00 718 120	<b>50 007 017</b> <small>NEW</small> (1)
	(1) Schalenhartguss/chilled cast iron/pièce moulée trempée en surface/fundición en coquilla/Отливка с отбеленным поверхностным слоем / (ST)					
[8]	M 35 x 30 x 33 x 7,55				77 00 102 349	<b>50 007 540</b>
[8]	M 35 x 30 x 33 x 7,6				77 00 102 351	<b>50 007 541</b>
[8]	M 35 x 30 x 33 x 7,65				77 00 102 353	<b>50 007 542</b>
[8]	M 35 x 30 x 33 x 7,7				77 00 102 355	<b>50 007 543</b>
[8]	M 35 x 30 x 33 x 7,75				77 00 102 357	<b>50 007 544</b>
[8]	M 35 x 30 x 33 x 7,8				77 00 102 359	<b>50 007 545</b>
[8]	M 35 x 30 x 33 x 7,85				77 00 102 361	<b>50 007 546</b>
[8]	M 35 x 30 x 33 x 7,9				77 00 102 363	<b>50 007 547</b>
[8]	M 35 x 30 x 33 x 7,95				77 00 103 628	<b>50 007 548</b>
[8]	M 35 x 30 x 33 x 8				77 00 103 630	<b>50 007 549</b>

## 23 76

**K9K**
**P 732**

05.2005 → 05.2009

D (A)

4

 1461 cm<sup>3</sup> 2V

78 kW

(106 PS)

18,8 80,50 mm

IN [2]	33,4 x 6 x 101,0	S - -	- 45° - -	22 - III	77 01 473 184 77 01 476 573	<b>539018</b>
[50]	Ø 6 mm					<b>MK-6H</b>
IN/EX [4]	11,05 x 6 x 40,5	B1				<b>81-51000</b> <small>NEW</small>
IN/EX [4]	11,25/8.8 x 6 x 40,5	B1				<b>81-51001</b> <small>NEW</small>

Fortsetzung nächste Seite / continued on next page / suite page suivante / continuación página próxima / Продолжение на следующей странице

					Reference	Item No.
	[8] M 35 x 30 x 33 x 7,55				77 00 102 349	50 007 540
	[8] M 35 x 30 x 33 x 7,6				77 00 102 351	50 007 541
	[8] M 35 x 30 x 33 x 7,65				77 00 102 353	50 007 542
	[8] M 35 x 30 x 33 x 7,7				77 00 102 355	50 007 543
	[8] M 35 x 30 x 33 x 7,75				77 00 102 357	50 007 544
	[8] M 35 x 30 x 33 x 7,8				77 00 102 359	50 007 545
	[8] M 35 x 30 x 33 x 7,85				77 00 102 361	50 007 546
	[8] M 35 x 30 x 33 x 7,9				77 00 102 363	50 007 547
	[8] M 35 x 30 x 33 x 7,95				77 00 103 628	50 007 548
	[8] M 35 x 30 x 33 x 8				77 00 103 630	50 007 549

**24** **76**  
**K9K** **792, 794, 796**  
 04.2007 → D (A) 4 1461 cm<sup>3</sup> 2V 48-63 kW (65-86 PS) 80,50 mm  
 40 190 6.., 40 465 6.., 41 068 6..

	IN [2] 33,4 x 6 x 101,0	S - -	- 45° - -	22 - III	77 01 473 184 77 01 476 573	539018
	EX [2] 28,9 x 6 x 100,8	RA/S- -	- 45° - -	22 - III	77 01 473 183 77 01 476 572	539017
	[50] Ø 6 mm					MK-6H
	IN/EX [4] 11,05 x 6 x 40,5	B1				81-51000
	IN/EX [4] 11,25/8.8 x 6 x 40,5	B1				81-51001
					82 00 089 894 82 00 679 572 82 00 978 873 82 01 004 849 82 01 033 581	50 006 314 (1) 50 007 076  (1)
	(1) (ST)					
	[8] M 35 x 30 x 33 x 7,55				77 00 102 349	50 007 540
	[8] M 35 x 30 x 33 x 7,6				77 00 102 351	50 007 541
	[8] M 35 x 30 x 33 x 7,65				77 00 102 353	50 007 542
	[8] M 35 x 30 x 33 x 7,7				77 00 102 355	50 007 543
	[8] M 35 x 30 x 33 x 7,75				77 00 102 357	50 007 544
	[8] M 35 x 30 x 33 x 7,8				77 00 102 359	50 007 545
	[8] M 35 x 30 x 33 x 7,85				77 00 102 361	50 007 546
	[8] M 35 x 30 x 33 x 7,95				77 00 103 628	50 007 548
	[8] M 35 x 30 x 33 x 8				77 00 103 630	50 007 549

**25** **76**  
**K9K** **830, 856, 858, 872, 898**  
 11.2008 → D (A) 4 1461 cm<sup>3</sup> 2V 59-85 kW (80-116 PS) 80,50 mm  
**K9K Euro 5** **656, 846**  
 10.2007 → D (A) 4 1461 cm<sup>3</sup> 2V 66-81 kW (90-110 PS) 80,50 mm  
 41 068 6.., 41 097 6..

	IN [2] 33,4 x 6 x 101,0	S - -	- 45° - -	22 - III	77 01 473 184 77 01 476 573	539018
	EX [2] 28,9 x 6 x 100,8	RA/S- -	- 45° - -	22 - III	77 01 473 183 77 01 476 572	539017
	[50] Ø 6 mm					MK-6H
	IN/EX [4] 11,05 x 6 x 40,5	B1				81-51000
	IN/EX [4] 11,25/8.8 x 6 x 40,5	B1				81-51001

Fortsetzung nächste Seite / continued on next page / suite page suivante / continuación página próxima / Продолжение на следующей странице

					Reference	Item No.
	[8]	M	35 x 30 x 33 x 7,55		77 00 102 349	50 007 540
	[8]	M	35 x 30 x 33 x 7,6		77 00 102 351	50 007 541
	[8]	M	35 x 30 x 33 x 7,65		77 00 102 353	50 007 542
	[8]	M	35 x 30 x 33 x 7,7		77 00 102 355	50 007 543
	[8]	M	35 x 30 x 33 x 7,75		77 00 102 357	50 007 544
	[8]	M	35 x 30 x 33 x 7,8		77 00 102 359	50 007 545
	[8]	M	35 x 30 x 33 x 7,85		77 00 102 361	50 007 546
	[8]	M	35 x 30 x 33 x 7,95		77 00 103 628	50 007 548
	[8]	M	35 x 30 x 33 x 8		77 00 103 630	50 007 549

**26**
**76**
**K9K**
**790**

02.2008 →

D

(A)

4

 1461 cm<sup>3</sup> 2V

48 kW

(65 PS) 18,3

80,50 mm

40 190 6.., 40 465 6..

	IN [2]	33,4 x 6 x 101,0	S - -	- 45° - -	22 - III	77 01 473 184 77 01 476 573	539018	
	EX [2]	28,9 x 6 x 100,8	RA/S- -	- 45° - -	22 - III	77 01 473 183 77 01 476 572	539017	
	[50]	∅ 6 mm					MK-6H	
	IN/EX [4]	11,05 x 6 x 40,5	B1				81-51000	
	IN/EX [4]	11,25/8.8 x 6 x 40,5	B1				81-51001	
						82 00 089 894 82 00 679 572 82 00 978 873 82 01 004 849 82 01 033 581 82 00 718 120	50 006 314 (2) 50 007 076  (2)  50 007 017  (1)	
	(1)	Schalenhartguss/chilled cast iron/pièce moulée trempée en surface/fundición en coquilla/Отливка с отбелнным поверхностным слоем / (ST)						
	(2)	(ST)						
	[8]	M	35 x 30 x 33 x 7,55			77 00 102 349	50 007 540	
	[8]	M	35 x 30 x 33 x 7,6			77 00 102 351	50 007 541	
	[8]	M	35 x 30 x 33 x 7,65			77 00 102 353	50 007 542	
	[8]	M	35 x 30 x 33 x 7,7			77 00 102 355	50 007 543	
	[8]	M	35 x 30 x 33 x 7,75			77 00 102 357	50 007 544	
	[8]	M	35 x 30 x 33 x 7,8			77 00 102 359	50 007 545	
	[8]	M	35 x 30 x 33 x 7,85			77 00 102 361	50 007 546	
	[8]	M	35 x 30 x 33 x 7,95			77 00 103 628	50 007 548	
	[8]	M	35 x 30 x 33 x 8			77 00 103 630	50 007 549	

**27**
**76**
**K9K**
**896**

02.2012 →

D

(A)

4

 1461 cm<sup>3</sup> 2V

81 kW

(110 PS) 15,2

80,50 mm

41 097 6..

	IN [2]	33,4 x 6 x 101,0	S - -	- 45° - -	22 - III	77 01 473 184 77 01 476 573	539018
	EX [2]	28,9 x 6 x 100,8	RA/S- -	- 45° - -	22 - III	77 01 473 183 77 01 476 572	539017
	[50]	∅ 6 mm					MK-6H
	IN/EX [4]	11,05 x 6 x 40,5	B1				81-51000
	IN/EX [4]	11,25/8.8 x 6 x 40,5	B1				81-51001

Fortsetzung nächste Seite / continued on next page / suite page suivante / continuación página próxima / Продолжение на следующей странице



					Reference	Item No.
					82 00 679 572 82 00 978 873 82 01 004 849 82 01 033 581	<b>50 007 076</b> <small>NEW</small> (1)
(1) (ST)						

<b>28</b>		<b>76</b>							
<b>K9K</b>		<b>658, 675, 886</b>	D (A)	4	1461 cm <sup>3</sup>	2V	80-81 kW	(109-110 PS)	80,50 mm
		10.2016 →							
	[8]	M 35 x 30 x 33 x 7,55					77 00 102 349		<b>50 007 540</b>
	[8]	M 35 x 30 x 33 x 7,6					77 00 102 351		<b>50 007 541</b>
	[8]	M 35 x 30 x 33 x 7,65					77 00 102 353		<b>50 007 542</b>
	[8]	M 35 x 30 x 33 x 7,7					77 00 102 355		<b>50 007 543</b>
	[8]	M 35 x 30 x 33 x 7,75					77 00 102 357		<b>50 007 544</b>
	[8]	M 35 x 30 x 33 x 7,8					77 00 102 359		<b>50 007 545</b>
	[8]	M 35 x 30 x 33 x 7,85					77 00 102 361		<b>50 007 546</b>
	[8]	M 35 x 30 x 33 x 7,95					77 00 103 628		<b>50 007 548</b>
	[8]	M 35 x 30 x 33 x 8					77 00 103 630		<b>50 007 549</b>

<b>29</b>		<b>77</b>							
<b>807</b>			B (NA)	4	1565 cm <sup>3</sup>	2V	49-61 kW	(67-83 PS)	8,6 84,00 mm
<b>807.04</b>		09.1968 → 08.1980	B (NA)	4	1565 cm <sup>3</sup>	2V	61 kW	(83 PS)	8,6 84,00 mm
<b>807.06</b>			B	4	1565 cm <sup>3</sup>	2V	61 kW	(83 PS)	8,6:1 84,00 mm
	EX [4]	13,14 x 8 x 49,0	G1				07 10 942 500		<b>81-5117</b>

<b>30</b>		<b>78</b>							
<b>F8M</b>		<b>700, 720, 730, 736, 760</b>	D (NA)	4		2V	40 kW	(55 PS)	22,5 83,50 mm
		10.1982 → 08.1998							
90 468 8..									
	[50]	∅ 8 mm							<b>KK-8H</b>

<b>31</b>		<b>79</b>							
<b>841</b>		<b>726</b>	B (NA)	4	1647 cm <sup>3</sup>	2V	58 kW	(79 PS)	9,3 84,00 mm
		04.1978 → 09.1982							
<b>841.25</b>			B	4	1647 cm <sup>3</sup>	2V	53-54 kW	(72-74 PS)	9,3:1 84,00 mm
<b>843.20</b>		10.1975 → 05.1977	B (NA)	4	1647 cm <sup>3</sup>	2V	66-71 kW	(90-97 PS)	9,3:1 84,00 mm
<b>843.21</b>		10.1975 → 05.1977	B (NA)	4	1647 cm <sup>3</sup>	2V	66-71 kW	(89-97 PS)	9,3:1 84,00 mm
	EX [4]	13,14 x 8 x 49,0	G1				07 10 942 500		<b>81-5117</b>

<b>32</b>		<b>79,5</b>							
<b>K7J</b>		<b>710</b>	B (NA)	4	1390 cm <sup>3</sup>	2V	55 kW	(75 PS)	9,5 70,00 mm
		09.2004 →							
<b>K7J</b>		<b>712</b>	B	4	1390 cm <sup>3</sup>	2V	70 kW	(95 PS)	10:1 70,00 mm
<b>K7M</b>		<b>720, 744, 745, 746, 790</b>	B (NA)	4	1598 cm <sup>3</sup>	2V	54-73 kW	(75-100 PS)	80,50 mm
		01.1996 →							
<b>K7M</b>		<b>702, 703, 704, 710, 750</b>	B (NA)	4	1598 cm <sup>3</sup>	2V	64-76 kW	(87-103 PS)	80,50 mm
		08.1995 →							
<b>K7M Euro 4</b>		<b>718, 732</b>	B (NA)	4	1598 cm <sup>3</sup>	2V	62-66 kW	(84-90 PS)	80,50 mm
		05.2008 →							
40 277 6.., 40 311 6..									

Fortsetzung nächste Seite / continued on next page / suite page suivante / continuación página próxima / Продолжение на следующей странице

					Reference	Item No.
IN [2]	37,6 x 7 x 107,7	S - -	- 30° - -	1 - III	60 01 548 030 77 00 273 371 77 00 273 373 77 00 853 390 77 01 465 088	<b>511017</b>
EX [2]	33,6 x 7 x 107,7	A/S - -	- 45° - -	1 - III	60 01 548 029 77 00 865 832 77 00 865 934 77 01 465 090 77 01 468 419	<b>511018</b>
[50]	Ø 7 mm				77 00 725 145	<b>KK-7H</b>
IN [4] EX [4]	12,06 x 7 x 42,0 12,06 x 7 x 49,0	B1 B1				<b>81-5133</b> <b>81-5134</b>

## 33 79,5

<b>K4J</b>	<b>712, 713, 714, 730, 732</b>	03.1999 →	B (NA)	4	1390 cm <sup>3</sup>	4V	60-72 kW	(82-98 PS)	10	70,00 mm
<b>K4J Euro 4</b>	<b>710, 711</b>	02.2000 → 07.2008	B (NA)	4	1390 cm <sup>3</sup>	4V	72 kW	(98 PS)	10	70,00 mm
<b>K4J</b>	<b>740, 750, 770, 780</b>	03.1999 →	B (NA)	4	1390 cm <sup>3</sup>	4V	70-72 kW	(95-98 PS)	10	70,00 mm
<b>K4M</b>	<b>690, 698, 700, 701, 704, 706, 708, 709, 710, 712, 714, 730, 732, 740, 742, 743, 746, 750, 752, 753, 754, 764, 776</b>	08.1996 →	B (NA)	4	1598 cm <sup>3</sup>	4V	66-98 kW	(90-133 PS)		80,50 mm
<b>K4M</b>	<b>720</b>	11.1997 → 03.2001	B (NA)	4	1598 cm <sup>3</sup>	4V	79 kW	(107 PS)	10	80,50 mm
<b>K4M Euro 4</b>	<b>744, 745, 830</b>		B (NA)	4	1598 cm <sup>3</sup>	4V	55-85 kW	(75-107 PS)		80,50 mm

40 015 6.., 99 746 6..

IN [2]	32,5 x 5,5 x 109,2	S - -	- 45° - -	1 - III	77 01 471 378 77 01 472 124	<b>531031</b>
EX [2]	28,0 x 5,5 x 107,5	A/S - -	- 45° - -	1 - III	77 01 471 354 77 01 471 379 77 01 473 354 77 01 473 355	<b>531032</b>
[50]	Ø 5,5 mm				77 00 873 652	<b>LK-5.5H</b>
IN/EX [4]	11,07 x 5,5 x 40,6	B1			77 00 109 151	<b>81-5136</b> (1)
	(1) ohne Ventilschaftabdichtung/without valve stem gasket/sans joint de tige de soupape/sin junta de vástagos de válvula/без уплотнения стержня клапана					
	AS				77 00 110 676 77 00 113 895 82 00 100 528	<b>50 006 315</b> (2)
	ES				77 00 110 675 77 00 113 894 82 00 100 527	<b>50 006 316</b> (2)
	(2) (ST)					
[8]	H 12 x 39 x 39				77 00 107 555	<b>50 006 437</b>
[4]					77 00 107 556 82 00 115 605	<b>50 006 486</b>

					Reference	Item No.	
<b>34</b>		<b>79,5</b>					
<b>K4J</b>	<b>700, 715</b>	10.1998 → 07.2008	B (NA) 4	1390 cm <sup>3</sup> 4V	70-72 kW (95-98 PS) 10	70,00 mm	
<b>K4M</b>	<b>711, 716, 734, 736, 760, 761, 762, 768, 782, 788, 790, 791, 792, 794</b>	11.2001 →	B (NA) 4	1598 cm <sup>3</sup> 4V	58-83 kW (79-113 PS)	80,50 mm	
<b>K4M Euro 4/5</b>	<b>854</b>	05.2008 →	B (NA) 4	1598 cm <sup>3</sup> 4V	98 kW (133 PS) 11	80,50 mm	
<b>K4M</b>	<b>755</b>		B	4 1598 cm <sup>3</sup> 4V	70 kW (95 PS) 10:1	80,50 mm	
<b>K4M</b>	<b>724</b>	11.1997 → 03.2001	B (NA) 4	1598 cm <sup>3</sup> 4V	79 kW (107 PS) 10	80,50 mm	
41 284 6..., 99 746 6..							
	IN [2]	32,5 x 5,5 x 109,2	S - -	- 45° - -	1 - III	77 01 471 378 77 01 472 124	<b>531031</b>
	EX [2]	28,0 x 5,5 x 107,5	A/S - -	- 45° - -	1 - III	77 01 471 354 77 01 471 379 77 01 473 354 77 01 473 355	<b>531032</b>
	[50]	∅ 5,5 mm				77 00 873 652	<b>LK-5.5H</b>
	IN/EX [4]	11,07 x 5.5 x 40,6	B1			77 00 109 151	<b>81-5136</b> (1)
	(1)	ohne Ventilschaftabdichtung/without valve stem gasket/sans joint de tige de soupape/sin junta de vástago de válvula/без уплотнения стержня клапана					
	[8]	H 12 x 39 x 39				77 00 107 555	<b>50 006 437</b>
	[4]					77 00 107 556 82 00 115 605	<b>50 006 486</b>
<b>35</b>		<b>79,5</b>					
<b>K4J</b>	<b>718</b>	10.1998 → 06.2001	B (NA) 4	1390 cm <sup>3</sup> 4V	70 kW (95 PS)	70,00 mm	
<b>K4M</b>	<b>616, 696, 707, 718, 766, 780, 8 788, 838, 839, 845, 866</b>	09.1999 →	B (NA) 4	1598 cm <sup>3</sup> 4V	75-86 kW (102-116 PS)	80,50 mm	
<b>K4M Euro 4</b>	<b>831, 834, 842, 848, 856, 858, 862</b>	11.2007 →	B (NA) 4	1598 cm <sup>3</sup> 4V	74-98 kW (101-133 PS)	80,50 mm	
<b>K4M Euro 4</b>	<b>260, 496, 497</b>		B	4 1598 cm <sup>3</sup> 4V	74-81 kW (101-110 PS)	80,50 mm	
<b>K4M</b>	<b>670, 674, 680</b>		B	4 1598 cm <sup>3</sup> 4V		80,50 mm	
41 284 6..., 99 746 6..							
	IN [2]	32,5 x 5,5 x 109,2	S - -	- 45° - -	1 - III	77 01 471 378 77 01 472 124	<b>531031</b>
	EX [2]	28,0 x 5,5 x 107,5	A/S - -	- 45° - -	1 - III	77 01 471 354 77 01 471 379 77 01 473 354 77 01 473 355	<b>531032</b>
	[50]	∅ 5,5 mm				77 00 873 652	<b>LK-5.5H</b>
	IN/EX [4]	11,07 x 5.5 x 40,6	B1			77 00 109 151	<b>81-5136</b> (1)
	(1)	ohne Ventilschaftabdichtung/without valve stem gasket/sans joint de tige de soupape/sin junta de vástago de válvula/без уплотнения стержня клапана					

					Reference	Item No.
<b>36</b>	<b>79,5</b>					
<b>K4M</b>	<b>800, 801, 804, 812, 813</b>					
	12.2004 →	B (NA)	4	1598 cm <sup>3</sup> 4V	65-82 kW (88-112 PS)	80,50 mm
<b>K4M Euro 4</b>	<b>824</b>					
	10.2007 → 12.2015	B (NA)	4	1598 cm <sup>3</sup> 4V	81 kW (110 PS) 9,8	80,50 mm
41 284 6..						
	IN [2]	32,5 x 5,5 x 109,2	S - -	- 45° - -	1 - III	77 01 471 378 77 01 472 124 <b>531031</b>
	EX [2]	28,0 x 5,5 x 107,5	A/S - -	- 45° - -	1 - III	77 01 471 354 77 01 471 379 77 01 473 354 77 01 473 355 <b>531032</b>
	[50]	∅ 5,5 mm				77 00 873 652 <b>LK-5.5H</b>
	IN/EX [4]	11,07 x 5.5 x 40,6	B1			77 00 109 151 <b>81-5136</b> (1)
	(1) ohne Ventilschaftabdichtung/without valve stem gasket/sans joint de tige de soupape/sin junta de vástago de válvula/без уплотнения стержня клапана					
	ES					82 00 235 677 <b>50 007 774</b> (2)
	AS					82 00 216 090 <b>50 007 776</b> (2)
	(2) Schalenhartguss/chilled cast iron/pièce moulée trempée en surface/fundición en coquilla/Отливка с отбеленным поверхностным слоем					
	[8]	H 12 x 39 x 39				77 00 107 555 <b>50 006 437</b>
	[4]					77 00 107 556 82 00 115 605 <b>50 006 486</b>
<b>37</b>	<b>79,5</b>					
<b>K4M</b>	<b>C 812, C 813</b>					
		B (NA)	4	1598 cm <sup>3</sup> 4V	82 kW (112 PS) 10,0:1	80,50 mm
41 284 6..						
	[8]	H 12 x 39 x 39				77 00 107 555 <b>50 006 437</b>
<b>38</b>	<b>79,5</b>					
<b>K4M</b>	<b>697, 748</b>					
	09.1998 →	AB (NA)	4	1598 cm <sup>3</sup> 4V	76-86 kW (103-117 PS)	80,50 mm
99 746 6..						
	IN [2]	32,5 x 5,5 x 109,2	S - -	- 45° - -	1 - III	77 01 471 378 77 01 472 124 <b>531031</b>
	EX [2]	28,0 x 5,5 x 107,5	A/S - -	- 45° - -	1 - III	77 01 471 354 77 01 471 379 77 01 473 354 77 01 473 355 <b>531032</b>
	[50]	∅ 5,5 mm				77 00 873 652 <b>LK-5.5H</b>
	IN/EX [4]	11,07 x 5.5 x 40,6	B1			77 00 109 151 <b>81-5136</b> (1)
	(1) ohne Ventilschaftabdichtung/without valve stem gasket/sans joint de tige de soupape/sin junta de vástago de válvula/без уплотнения стержня клапана					
Fortsetzung nächste Seite / continued on next page / suite page suivante / continuación página próxima / Продолжение на следующей странице						

					Reference	Item No.
	AS				77 00 110 676 77 00 113 895 82 00 100 528	<b>50 006 315</b> (2)
	ES				77 00 110 675 77 00 113 894 82 00 100 527	<b>50 006 316</b> (2)
	(2) (ST)					
	[8] H 12 x 39 x 39				77 00 107 555	<b>50 006 437</b>
	[4]				77 00 107 556 82 00 115 605	<b>50 006 486</b>

<b>39</b>		<b>79,5</b>							
<b>K4M</b>		<b>694, 850</b>							
		01.2002 →		AB (NA) 4		1598 cm <sup>3</sup> 4V		60-81 kW (82-106 PS) 80,50 mm	
	IN [2]	32,5 x 5,5 x 109,2	S - -	- 45° -	-	1 - III	77 01 471 378 77 01 472 124	<b>531031</b>	
	EX [2]	28,0 x 5,5 x 107,5	A/S - -	- 45° -	-	1 - III	77 01 471 354 77 01 471 379 77 01 473 354 77 01 473 355	<b>531032</b>	
	[50]	Ø 5,5 mm					77 00 873 652	<b>LK-5.5H</b>	
	IN/EX [4]	11,07 x 5,5 x 40,6	B1				77 00 109 151	<b>81-5136</b> (1)	
	(1) ohne Ventilschaftabdichtung/without valve stem gasket/sans joint de tige de soupape/sin junta de vástago de válvula/без уплотнения стержня клапана								

<b>40</b>		<b>80</b>							
<b>F8Q</b>		<b>610, 731, 736, 740, 744, 768, 785, 788</b>							
		09.1990 →		D (A) 4		1870 cm <sup>3</sup> 2V		47-72 kW (64-98 PS) 93,00 mm	
	<b>F8Q</b>	<b>640, 706, 710</b>							
		03.1986 → 03.1998	D (NA) 4	1870 cm <sup>3</sup> 2V	40-48 kW	(54-65 PS)	21,5	93,00 mm	
	<b>F8Q</b>	<b>672, 692, 704</b>							
		10.1980 →	D 4	1870 cm <sup>3</sup> 2V	47-48 kW	(64-65 PS)	21,5:1	93,00 mm	
92 006 8.., 94 357 6..									
	[50]	Ø 8 mm						<b>KK-8H</b>	
	IN/EX [4]	13,07 x 8 x 37,7	B1					<b>81-47103</b>	

<b>41</b>		<b>80</b>							
<b>F8Q</b>		<b>622</b>							
		08.1995 → 08.2003		D (NA) 4		1870 cm <sup>3</sup> 2V		47 kW (64 PS) 21,5 93,00 mm	
	<b>F8Q</b>	<b>784</b>							
		05.1989 → 08.2003	D (A) 4	1870 cm <sup>3</sup> 2V	66-76 kW	(90-104 PS)	20,5	93,00 mm	
94 357 6..									
	[50]	Ø 8 mm						<b>KK-8H</b>	
	IN/EX [4]	13,07 x 8 x 37,7	B1					<b>81-47103</b>	
							77 00 106 678	<b>50 006 198</b> (1)	
Fortsetzung nächste Seite / continued on next page / suite page suivante / continuación página próxima / Продолжение на следующей странице									

					Reference	Item No.
(1)	Schalenhartguss/chilled cast iron/pièce moulée trempée en surface/fundición en coquilla/Отливка с отбелнным поверхностным слоем					
[8]	M 35 x 26,5 x 26,5				77 00 100 939	50 006 427
<b>42</b>	<b>80</b>					
<b>F8Q</b>	<b>606, 620, 624, 644, 646, 676, 678, 684, 696, 714, 722, 724, 730, 732, 742, 764, 774, 776</b>					
92 006 8..	09.1990 →	D (NA)	4	1870 cm <sup>3</sup> 2V	40-66 kW (54-90 PS)	93,00 mm
[50]	∅ 8 mm					KK-8H
IN/EX [4]	13,07 x 8 x 37,7	B1				81-47103
[8]	M 35 x 26,5 x 26,5				77 00 100 939	50 006 427
<b>43</b>	<b>80</b>					
<b>F8Q</b>	<b>648, 680, 682</b>					
92 006 8..	09.1994 →	D (NA)	4	1870 cm <sup>3</sup> 2V	40-66 kW (54-90 PS)	93,00 mm
[50]	∅ 8 mm					KK-8H
IN/EX [4]	13,07 x 8 x 37,7	B1				81-47103
[8]	M 35 x 26,5 x 26,5				77 00 100 939	50 006 427
[8]	M 35 x 30 x 33 x 7,55				77 00 102 349	50 007 540
[8]	M 35 x 30 x 33 x 7,6				77 00 102 351	50 007 541
[8]	M 35 x 30 x 33 x 7,65				77 00 102 353	50 007 542
[8]	M 35 x 30 x 33 x 7,7				77 00 102 355	50 007 543
[8]	M 35 x 30 x 33 x 7,75				77 00 102 357	50 007 544
[8]	M 35 x 30 x 33 x 7,8				77 00 102 359	50 007 545
[8]	M 35 x 30 x 33 x 7,85				77 00 102 361	50 007 546
[8]	M 35 x 30 x 33 x 7,9				77 00 102 363	50 007 547
[8]	M 35 x 30 x 33 x 7,95				77 00 103 628	50 007 548
[8]	M 35 x 30 x 33 x 8				77 00 103 630	50 007 549
<b>44</b>	<b>80</b>					
<b>F8Q</b>	<b>786</b>					
94 357 6..	01.1996 → 08.2003	D (A)	4	1870 cm <sup>3</sup> 2V	66 kW (90 PS) 20,5	93,00 mm
[50]	∅ 8 mm					KK-8H
IN/EX [4]	13,07 x 8 x 37,7	B1				81-47103
[8]	M 35 x 30 x 33 x 7,55				77 00 102 349	50 007 540
[8]	M 35 x 30 x 33 x 7,6				77 00 102 351	50 007 541
[8]	M 35 x 30 x 33 x 7,65				77 00 102 353	50 007 542
[8]	M 35 x 30 x 33 x 7,7				77 00 102 355	50 007 543
[8]	M 35 x 30 x 33 x 7,75				77 00 102 357	50 007 544
[8]	M 35 x 30 x 33 x 7,8				77 00 102 359	50 007 545
[8]	M 35 x 30 x 33 x 7,85				77 00 102 361	50 007 546
[8]	M 35 x 30 x 33 x 7,9				77 00 102 363	50 007 547
[8]	M 35 x 30 x 33 x 7,95				77 00 103 628	50 007 548
[8]	M 35 x 30 x 33 x 8				77 00 103 630	50 007 549



					Reference	Item No.		
<b>45</b>	<b>80</b>							
<b>F8Q</b>	<b>632, 790</b>							
40 070 6..	05.1996 →	D (NA)	4	1870 cm <sup>3</sup>	2V	47-48 kW (64-65 PS) 21,5 93,00 mm		
	[50] Ø 8 mm					<b>KK-8H</b>		
	IN/EX [4] 13,07 x 8 x 37,7	B1				<b>81-47103</b>		
					77 00 106 678	<b>50 006 198</b> (1)		
	(1) Schalenhartguss/chilled cast iron/pièce moulée trempée en surface/fundición en coquilla/Отливка с отбеленным поверхностным слоем							
	[8] M 35 x 30 x 33 x 7,55				77 00 102 349	<b>50 007 540</b>		
	[8] M 35 x 30 x 33 x 7,6				77 00 102 351	<b>50 007 541</b>		
	[8] M 35 x 30 x 33 x 7,65				77 00 102 353	<b>50 007 542</b>		
	[8] M 35 x 30 x 33 x 7,7				77 00 102 355	<b>50 007 543</b>		
	[8] M 35 x 30 x 33 x 7,75				77 00 102 357	<b>50 007 544</b>		
	[8] M 35 x 30 x 33 x 7,8				77 00 102 359	<b>50 007 545</b>		
	[8] M 35 x 30 x 33 x 7,85				77 00 102 361	<b>50 007 546</b>		
	[8] M 35 x 30 x 33 x 7,9				77 00 102 363	<b>50 007 547</b>		
	[8] M 35 x 30 x 33 x 7,95				77 00 103 628	<b>50 007 548</b>		
	[8] M 35 x 30 x 33 x 8				77 00 103 630	<b>50 007 549</b>		
<b>46</b>	<b>80</b>							
<b>F9Q</b>	<b>716, 730, 734</b>							
	03.1997 → 08.2003	D (A)	4	1870 cm <sup>3</sup>	2V	60-75 kW (82-102 PS) 18,3 93,00 mm		
<b>F9Q</b>	<b>710, 717, 731, 736</b>							
	03.1997 → 08.2003	D (A)	4	1870 cm <sup>3</sup>	2V	72-75 kW (98-102 PS) 18,3 93,00 mm		
99 561 6..								
	IN [2] 35,3 x 7 x 110,9	S - -		- 45° -	-	1 - III	77 00 110 386 77 00 110 387 77 01 471 702 77 01 476 024 82 00 828 299	<b>511013</b>
	EX [2] 32,6 x 7 x 110,7	A/S - -		- 45° -		1 - III	77 00 110 388 77 00 110 389 77 01 471 703 77 01 476 025 77 01 476 256 82 00 872 426	<b>511014</b>
	[50] Ø 7 mm						77 00 725 145	<b>KK-7H</b>
	IN/EX [4] 12,06 x 7 x 38,3	B1					77 00 859 086	<b>81-5135</b>
							82 00 084 742	<b>50 006 332</b> (1)
	(1) Schalenhartguss/chilled cast iron/pièce moulée trempée en surface/fundición en coquilla/Отливка с отбеленным поверхностным слоем							
Fortsetzung nächste Seite / continued on next page / suite page suivante / continuación página próxima / Продолжение на следующей странице								

					Reference	Item No.	
	[8]	M	35 x 30 x 33 x 7,55			77 00 102 349	<b>50 007 540</b>
	[8]	M	35 x 30 x 33 x 7,6			77 00 102 351	<b>50 007 541</b>
	[8]	M	35 x 30 x 33 x 7,65			77 00 102 353	<b>50 007 542</b>
	[8]	M	35 x 30 x 33 x 7,7			77 00 102 355	<b>50 007 543</b>
	[8]	M	35 x 30 x 33 x 7,75			77 00 102 357	<b>50 007 544</b>
	[8]	M	35 x 30 x 33 x 7,8			77 00 102 359	<b>50 007 545</b>
	[8]	M	35 x 30 x 33 x 7,85			77 00 102 361	<b>50 007 546</b>
	[8]	M	35 x 30 x 33 x 7,9			77 00 102 363	<b>50 007 547</b>
	[8]	M	35 x 30 x 33 x 7,95			77 00 103 628	<b>50 007 548</b>
	[8]	M	35 x 30 x 33 x 8			77 00 103 630	<b>50 007 549</b>

## 47 80

**F8Q**
**630, 662**

02.1998 →

D

(NA)

4

 1870 cm<sup>3</sup> 2V

40-48 kW

(54-65 PS) 21,5

93,00 mm

40 070 6..

	[50]	∅ 8 mm					<b>KK-8H</b>
	IN/EX [4]	13,07 x 8 x 37,7	B1				<b>81-47103</b>
						77 00 106 678	<b>50 006 198</b> (1)
	(1) Schalenhartguss/chilled cast iron/pièce moulée trempée en surface/fundición en coquilla/Отливка с отбеленным поверхностным слоем						
	[8]	M	35 x 26,5 x 26,5			77 00 100 939	<b>50 006 427</b>
	[8]	M	35 x 30 x 33 x 7,55			77 00 102 349	<b>50 007 540</b>
	[8]	M	35 x 30 x 33 x 7,6			77 00 102 351	<b>50 007 541</b>
	[8]	M	35 x 30 x 33 x 7,65			77 00 102 353	<b>50 007 542</b>
	[8]	M	35 x 30 x 33 x 7,7			77 00 102 355	<b>50 007 543</b>
	[8]	M	35 x 30 x 33 x 7,75			77 00 102 357	<b>50 007 544</b>
	[8]	M	35 x 30 x 33 x 7,8			77 00 102 359	<b>50 007 545</b>
	[8]	M	35 x 30 x 33 x 7,85			77 00 102 361	<b>50 007 546</b>
	[8]	M	35 x 30 x 33 x 7,9			77 00 102 363	<b>50 007 547</b>
	[8]	M	35 x 30 x 33 x 7,95			77 00 103 628	<b>50 007 548</b>
	[8]	M	35 x 30 x 33 x 8			77 00 103 630	<b>50 007 549</b>

## 48 80

**F9Q**
**722**

02.1999 → 12.2003

D

(A)

4

 1870 cm<sup>3</sup> 2V

72 kW

(98 PS) 18,3

93,00 mm

	IN [2]	35,3 x 7 x 110,9	S - -	- 45° - -	1 - III	77 00 110 386 77 00 110 387 77 01 471 702 77 01 476 024 82 00 828 299	<b>511013</b>
	EX [2]	32,6 x 7 x 110,7	A/S - -	- 45° - -	1 - III	77 00 110 388 77 00 110 389 77 01 471 703 77 01 476 025 77 01 476 256 82 00 872 426	<b>511014</b>
	[50]	∅ 7 mm				77 00 725 145	<b>KK-7H</b>
	IN/EX [4]	12,06 x 7 x 38,3	B1			77 00 859 086	<b>81-5135</b>
						82 00 084 742	<b>50 006 332</b> (1)

Fortsetzung nächste Seite / continued on next page / suite page suivante / continuación página próxima / Продолжение на следующей странице

					Reference	Item No.
(1)	Schalenhartguss/chilled cast iron/pièce moulée trempée en surface/fundición en coquilla/Отливка с отбеленным поверхностным слоем					
	[8]	M	35 x 26,5 x 26,5		77 00 100 939	50 006 427
	[8]	M	35 x 30 x 33 x 7,55		77 00 102 349	50 007 540
	[8]	M	35 x 30 x 33 x 7,6		77 00 102 351	50 007 541
	[8]	M	35 x 30 x 33 x 7,65		77 00 102 353	50 007 542
	[8]	M	35 x 30 x 33 x 7,7		77 00 102 355	50 007 543
	[8]	M	35 x 30 x 33 x 7,75		77 00 102 357	50 007 544
	[8]	M	35 x 30 x 33 x 7,8		77 00 102 359	50 007 545
	[8]	M	35 x 30 x 33 x 7,85		77 00 102 361	50 007 546
	[8]	M	35 x 30 x 33 x 7,9		77 00 102 363	50 007 547
	[8]	M	35 x 30 x 33 x 7,95		77 00 103 628	50 007 548
	[8]	M	35 x 30 x 33 x 8		77 00 103 630	50 007 549

## 49 80

**F9Q** 650, 664, 670, 674, 680, 746, 748, 756, 758, 759, 774, 803, 808, 812, 816, 818, 820, 826, J 803  
 03.1999 → D (A) 4 1870 cm<sup>3</sup> 2V 60-96 kW (82-131 PS) 93,00 mm  
 99 561 6..., 99 780 6..., 99 940 6...

	IN [2]	35,3 x 7 x 110,9	S - -	- 45° - -	1 - III	77 00 110 386 77 00 110 387 77 01 471 702 77 01 476 024 82 00 828 299	511013
	EX [2]	32,6 x 7 x 110,7	A/S - -	- 45° - -	1 - III	77 00 110 388 77 00 110 389 77 01 471 703 77 01 476 025 77 01 476 256 82 00 872 426	511014
	[50]	Ø 7 mm				77 00 725 145	KK-7H
	IN/EX [4]	12,06 x 7 x 38,3	B1			77 00 859 086	81-5135
						82 00 084 742	50 006 332 (1)
(1)	Schalenhartguss/chilled cast iron/pièce moulée trempée en surface/fundición en coquilla/Отливка с отбеленным поверхностным слоем						

R

## 50 80

**F9Q** 732, 733, 740  
 03.1999 → 08.2003 D (A) 4 1870 cm<sup>3</sup> 2V 74-77 kW (101-105 PS) 19 93,00 mm  
**F9Q** 718, 750, 751, 752, 754, 760, 762, 770, 772, 780, 782, 790  
 09.1999 → D (A) 4 1870 cm<sup>3</sup> 2V 59-92 kW (80-125 PS) 93,00 mm  
 99 561 6..., 99 780 6...

	IN [2]	35,3 x 7 x 110,9	S - -	- 45° - -	1 - III	77 00 110 386 77 00 110 387 77 01 471 702 77 01 476 024 82 00 828 299	511013
	EX [2]	32,6 x 7 x 110,7	A/S - -	- 45° - -	1 - III	77 00 110 388 77 00 110 389 77 01 471 703 77 01 476 025 77 01 476 256 82 00 872 426	511014
	[50]	Ø 7 mm				77 00 725 145	KK-7H

Fortsetzung nächste Seite / continued on next page / suite page suivante / continuación página próxima / Продолжение на следующей странице

					Reference	Item No.
	IN/EX [4]	12,06 x 7 x 38,3	B1		77 00 859 086	<b>81-5135</b>
	[8]	M 35 x 30 x 33 x 7,55			77 00 102 349	<b>50 007 540</b>
	[8]	M 35 x 30 x 33 x 7,6			77 00 102 351	<b>50 007 541</b>
	[8]	M 35 x 30 x 33 x 7,65			77 00 102 353	<b>50 007 542</b>
	[8]	M 35 x 30 x 33 x 7,7			77 00 102 355	<b>50 007 543</b>
	[8]	M 35 x 30 x 33 x 7,75			77 00 102 357	<b>50 007 544</b>
	[8]	M 35 x 30 x 33 x 7,8			77 00 102 359	<b>50 007 545</b>
	[8]	M 35 x 30 x 33 x 7,85			77 00 102 361	<b>50 007 546</b>
	[8]	M 35 x 30 x 33 x 7,9			77 00 102 363	<b>50 007 547</b>
	[8]	M 35 x 30 x 33 x 7,95			77 00 103 628	<b>50 007 548</b>
	[8]	M 35 x 30 x 33 x 8			77 00 103 630	<b>50 007 549</b>

## 51

**F9Q Euro 4**

**E 804, EE 804**

03.1999 → 05.2009 D (A) 4 1870 cm<sup>3</sup> 2V 81-96 kW (110-131 PS) 17 93,00 mm

**F9Q**

**738**

03.1999 → 08.2003 D (A) 4 1870 cm<sup>3</sup> 2V 59-79 kW (80-107 PS) 19 93,00 mm

**F9Q**

**744, 800, 804**

03.1999 → D (A) 4 1870 cm<sup>3</sup> 2V 59-97 kW (80-132 PS) 93,00 mm

99 561 6.., 99 780 6.., 99 940 6..

	IN [2]	35,3 x 7 x 110,9	S - -	- 45° - -	1 - III	77 00 110 386 77 00 110 387 77 01 471 702 77 01 476 024 82 00 828 299	<b>511013</b>
	EX [2]	32,6 x 7 x 110,7	A/S - -	- 45° - -	1 - III	77 00 110 388 77 00 110 389 77 01 471 703 77 01 476 025 77 01 476 256 82 00 872 426	<b>511014</b>

	[50]	∅ 7 mm				77 00 725 145	<b>KK-7H</b>
--	------	--------	--	--	--	---------------	--------------

	IN/EX [4]	12,06 x 7 x 38,3	B1			77 00 859 086	<b>81-5135</b>
--	-----------	------------------	----	--	--	---------------	----------------

## 52

**R9M Euro 5**

**402, 404**

04.2011 → D (A) 4 1598 cm<sup>3</sup> 4V 96 kW (130 PS) 15,4 79,50 mm

40 892 6..

	IN [2]	23,5 x 6 x 104,2	S - -	- 45° - -	22 - III	13 20 103 70R	<b>539044</b> <small>NEW</small>
	EX [2]	23,4 x 6 x 104,1	RA/S- -	- 45° - -	22 - III	13 20 248 94R	<b>539045</b> <small>NEW</small>

	[50]	∅ 6 mm					<b>MK-6H</b>
--	------	--------	--	--	--	--	--------------

	IN/EX [4]	11,05 x 6 x 40,5	B1				<b>81-51000</b> <small>NEW</small>
	IN/EX [4]	11,25/8.8 x 6 x 40,5	B1				<b>81-51001</b> <small>NEW</small>

## 53

**R9M**

**408, 413, 414, 450, 452, 453**

04.2011 → D (A) 4 1598 cm<sup>3</sup> 4V 66-120 kW (90-163 PS) 15,4 79,50 mm

**R9M Euro 5**

**409**

06.2015 → D (A) 4 1598 cm<sup>3</sup> 4V 96 kW (130 PS) 15,4 79,50 mm

40 892 6..

	IN [2]	23,5 x 6 x 104,2	S - -	- 45° - -	22 - III	13 20 103 70R	<b>539044</b> <small>NEW</small>
	EX [2]	23,4 x 6 x 104,1	RA/S- -	- 45° - -	22 - III	13 20 248 94R	<b>539045</b> <small>NEW</small>

Fortsetzung nächste Seite / continued on next page / suite page suivante / continuación página próxima / Продолжение на следующей странице

					Reference	Item No.	
[50]	Ø 6 mm					MK-6H	
<b>54</b>	<b>80</b>						
<b>F8Q</b>	<b>636</b>	D (NA)	4	1870 cm <sup>3</sup>	2V	45 kW (61 PS) 21,5:1 93,00 mm	
92 006 8..							
[50]	Ø 8 mm					KK-8H	
					77 00 106 678	<b>50 006 198</b> (1)	
(1) Schalenhartguss/chilled cast iron/pièce moulée trempée en surface/fundición en coquilla/Отливка с отбеленным поверхностным слоем							
<b>55</b>	<b>80</b>						
<b>F9Q</b>	<b>720</b>	D (A)	4	1870 cm <sup>3</sup>	2V	72 kW (98 PS) 18,3:1 93,00 mm	
IN [2]	35,3 x 7 x 110,9	S - -		- 45° -	-	1 - III 77 00 110 386 77 00 110 387 77 01 471 702 77 01 476 024 82 00 828 299	<b>511013</b>
EX [2]	32,6 x 7 x 110,7	A/S - -		- 45° -	-	1 - III 77 00 110 388 77 00 110 389 77 01 471 703 77 01 476 025 77 01 476 256 82 00 872 426	<b>511014</b>
[50]	Ø 7 mm					77 00 725 145	KK-7H
IN/EX [4]	12,06 x 7 x 38,3	B1				77 00 859 086	<b>81-5135</b>
[8]	M 35 x 26,5 x 26,5					77 00 100 939	<b>50 006 427</b>
[8]	M 35 x 30 x 33 x 7,55					77 00 102 349	<b>50 007 540</b>
[8]	M 35 x 30 x 33 x 7,6					77 00 102 351	<b>50 007 541</b>
[8]	M 35 x 30 x 33 x 7,65					77 00 102 353	<b>50 007 542</b>
[8]	M 35 x 30 x 33 x 7,7					77 00 102 355	<b>50 007 543</b>
[8]	M 35 x 30 x 33 x 7,75					77 00 102 357	<b>50 007 544</b>
[8]	M 35 x 30 x 33 x 7,8					77 00 102 359	<b>50 007 545</b>
[8]	M 35 x 30 x 33 x 7,85					77 00 102 361	<b>50 007 546</b>
[8]	M 35 x 30 x 33 x 7,9					77 00 102 363	<b>50 007 547</b>
[8]	M 35 x 30 x 33 x 7,95					77 00 103 628	<b>50 007 548</b>
[8]	M 35 x 30 x 33 x 8					77 00 103 630	<b>50 007 549</b>
<b>56</b>	<b>81</b>						
<b>F1N</b>	<b>720, 722, 724</b>						
	06.1986 → 08.1994	B (NA)	4	1721 cm <sup>3</sup>	2V	50-51 kW (68-69 PS) 9,5 83,50 mm	
<b>F2N</b>	<b>700, 704, 708, 710, 711, 716, 720, 721, 722, 726, 727, 728, 730, 732, 740, 742, 750, 753, 754, 758, 770, 783, 786, 796, 797</b>						
	09.1983 →	B (NA)	4	1721 cm <sup>3</sup>	2V	54-69 kW (73-94 PS) 83,50 mm	
<b>F2N</b>	<b>712, 724, 752, 798</b>						
	03.1986 → 05.1993	B (NA)	4	1721 cm <sup>3</sup>	2V	55-65 kW (75-88 PS) 83,50 mm	
<b>F2R</b>	<b>702</b>	B	4	1721 cm <sup>3</sup>	2V	66 kW (90 PS) 9,5:1 83,50 mm	
<b>F3N</b>	<b>708, 722</b>						
	04.1986 → 12.1996	B (NA)	4	1721 cm <sup>3</sup>	2V	66-70 kW (90-95 PS) 9,5 83,50 mm	
<b>F3N</b>	<b>702, 716, 717, 718, 723, 726, 740, 741, 742, 743, 746</b>						
	10.1984 → 12.1996	B (NA)	4	1721 cm <sup>3</sup>	2V	54-80 kW (73-109 PS) 83,50 mm	
Fortsetzung nächste Seite / continued on next page / suite page suivante / continuación página próxima / Продолжение на следующей странице							

R

					Reference	Item No.
EX [2]	32,5 x 8 x 111,3	A/S - -	- 45° - VS -	1 - III	77 01 463 082	<b>517981</b>
[50]	Ø 8 mm					<b>KK-8H</b>
EX [4]	13,14 x 8 x 49,0	G1			07 10 942 500	<b>81-5117</b>
<b>57</b>	<b>81</b>					
<b>B 172 K</b>		B	4	1709 cm <sup>3</sup> 2V	59 kW (80 PS) 10:1	82,90 mm
EX [2]	32,5 x 8 x 111,3	A/S - -	- 45° - VS -	1 - III	77 01 463 082	<b>517981</b>
[50]	Ø 7 mm				77 00 725 145	<b>KK-7H</b>
[50]	Ø 8 mm					<b>KK-8H</b>
IN/EX [4]	13,07 x 8 x 37,7	B1				<b>81-47103</b>
EX [4]	13,14 x 8 x 49,0	G1			07 10 942 500	<b>81-5117</b>
<b>58</b>	<b>82</b>					
<b>F7P</b>	<b>720, 722</b>					
	08.1991 →	B (NA)	4	1764 cm <sup>3</sup> 4V	99-103 kW (135-140 PS)	83,50 mm
<b>F7P</b>	<b>700</b>					
	06.1989 → 12.1997	B (NA)	4	1764 cm <sup>3</sup> 4V	101-103 kW (137-140 PS) 10	83,50 mm
[50]	Ø 7 mm				77 00 725 145	<b>KK-7H</b>
IN/EX [4]	12,06 x 7.01 x 39,2	B1			77 00 743 529	<b>81-5131</b>
<b>59</b>	<b>82</b>					
<b>F7P</b>	<b>704</b>					
	06.1991 → 06.1996	B (NA)	4	1764 cm <sup>3</sup> 4V	99-101 kW (135-137 PS) 10,1	83,50 mm
[50]	Ø 7 mm				77 00 725 145	<b>KK-7H</b>
IN/EX [4]	12,06 x 7.01 x 39,2	B1			77 00 743 529	<b>81-5131</b>
[8]	H 33 x 26				7700744596	<b>50 007 604</b>
<b>60</b>	<b>82,7</b>					
<b>F3P</b>	<b>755</b>					
	08.1990 → 09.1998	B (NA)	4	1783 cm <sup>3</sup> 2V	66 kW (90 PS) 9,8	83,00 mm
<b>F3P</b>	<b>744, 745, 748</b>					
		B	4	1794 cm <sup>3</sup> 2V	66-80 kW (90-109 PS) 9,8:1	83,50 mm
<b>F3P</b>	<b>670, 676</b>					
	06.1995 → 03.2001	B (NA)	4	1794 cm <sup>3</sup> 2V	66-70 kW (90-95 PS) 9,7	83,50 mm
<b>F3P</b>	<b>754, 758</b>					
	08.1994 → 09.1998	B (NA)	4	1794 cm <sup>3</sup> 2V	66-80 kW (90-109 PS) 9,8	83,50 mm
<b>F3R</b>	<b>750, 751, 752, 791, 797</b>					
	01.1996 → 08.2003	B (NA)	4	1998 cm <sup>3</sup> 2V	80-85 kW (109-115 PS) 9,7	93,00 mm
IN [2]	40,2 x 8 x 107,0	S - -	- 45° - - -	1 - III	77 01 466 606	<b>510201</b>
EX [2]	32,6 x 8 x 107,0	A/S - -	- 45° - VS -	1 - III	77 01 466 607	<b>510202</b>
[50]	Ø 8 mm					<b>KK-8H</b>
Fortsetzung nächste Seite / continued on next page / suite page suivante / continuación página próxima / Продолжение на следующей странице						



					Reference	Item No.	
	IN/EX [4] 13,07 x 8 x 37,7	B1				<b>81-47103</b>	
	[8] M 35 x 26,5 x 26,5				77 00 100 939	<b>50 006 427</b>	
<b>61</b>	<b>82,7</b>						
<b>F3P</b>	<b>764</b> 07.1994 → 06.1996 B (NA) 4 1783 cm <sup>3</sup> 2V 79 kW (107 PS) 9,7 83,00 mm						
<b>F3P</b>	<b>674, 678, 700, 704, 705, 706, 707, 708, 710, 760, 765</b> 01.1991 → 03.2001 B (NA) 4 1794 cm <sup>3</sup> 2V 65-83 kW (88-110 PS) 9,7 83,50 mm						
<b>F3P</b>	<b>682, 712, 714, 720, 724</b> 01.1991 → 03.2001 B (NA) 4 1794 cm <sup>3</sup> 2V 65-80 kW (88-109 PS) 83,50 mm						
<b>F3R</b>	<b>722, 723, 742, 769, 796, 798</b> 12.1993 → 08.2003 B (NA) 4 1998 cm <sup>3</sup> 2V 80-85 kW (109-115 PS) 93,00 mm						
<b>F3R</b>	<b>611</b> 03.1999 → 03.2001 B (NA) 4 1998 cm <sup>3</sup> 2V 80-85 kW (109-116 PS) 9,5 93,00 mm						
	IN [2] 40,2 x 8 x 107,0 EX [2] 32,6 x 8 x 107,0	S - - A/S - -	- 45° - - - 45° - VS -	1 - III 1 - III	77 01 466 606 77 01 466 607	<b>510201</b> <b>510202</b>	
	[50] Ø 8 mm						<b>KK-8H</b>
	IN/EX [4] 13,07 x 8 x 37,7	B1				<b>81-47103</b>	
<b>62</b>	<b>82,7</b>						
<b>F7R</b>	<b>710, 714, 720</b> 03.1995 → B (NA) 4 1998 cm <sup>3</sup> 4V 108-110 kW (147-150 PS) 93,00 mm						
<b>F7R</b>	<b>700</b> 01.1994 → 09.1998 B (NA) 4 1998 cm <sup>3</sup> 4V 108-110 kW (147-150 PS) 10 93,00 mm						
	IN [2] 33,0 x 7 x 107,2 EX [2] 28,4 x 7 x 108,8	S - - A/S - -	- 45° - - - 45° - VS -	1 - III 1 - III	77 00 865 550 77 00 865 551	<b>511011</b> <b>511012</b>	
	[50] Ø 7 mm						77 00 725 145 <b>KK-7H</b>
	[8] H 33 x 26						7700744596 <b>50 007 604</b>
<b>63</b>	<b>82,7</b>						
<b>F3R</b>	<b>768</b> 06.1995 → 02.2001 B (NA) 4 1998 cm <sup>3</sup> 2V 84 kW (114 PS) 9,8 93,00 mm						
	[50] Ø 8 mm						<b>KK-8H</b>
	IN/EX [4] 13,07 x 8 x 37,7	B1				<b>81-47103</b>	
<b>64</b>	<b>82,7</b>						
<b>F3R</b>	<b>728, 729</b> 11.1996 → 01.2001 B (NA) 4 1998 cm <sup>3</sup> 2V 84 kW (114 PS) 9,8 93,00 mm						
	[50] Ø 8 mm						<b>KK-8H</b>
	IN/EX [4] 13,07 x 8 x 37,7	B1				<b>81-47103</b>	
	[8] M 35 x 26,5 x 26,5						77 00 100 939 <b>50 006 427</b>

**R**

					Reference	Item No.	
<b>65</b>	<b>82,7</b>						
<b>F4P</b>	<b>720, 722, 760, 770, 774</b>						
	04.1998 → 12.2007	B (NA)	4	1783 cm <sup>3</sup>	4V 85-89 kW (115-121 PS)	9,8 83,00 mm	
<b>F4R</b>	<b>760, 761, 762, 763, 764, 765, 776, 784, 787, 796</b>						
	11.2001 →	B (A)	4	1998 cm <sup>3</sup>	4V 120-125 kW (163-170 PS)	9,5 93,00 mm	
<b>F4R Euro 4</b>	<b>766, 767</b>						
	04.2004 →	B (A)	4	1998 cm <sup>3</sup>	4V 125 kW (170 PS)	9,5 93,00 mm	
<b>F4R</b>	<b>700, 701, 722</b>						
	10.1998 →	B (NA)	4	1998 cm <sup>3</sup>	4V 88-103 kW (120-140 PS)	9,8 93,00 mm	
<b>F4R Euro 3</b>	<b>738</b>						
	01.2004 → 04.2005	B (NA)	4	1998 cm <sup>3</sup>	4V 124-132 kW (168-180 PS)	11 93,00 mm	
<b>F4R</b>	<b>774, 786, 794, 795, 797, 800, 811, 813, 886, 887</b>						
	11.2002 →	B (LA)	4	1998 cm <sup>3</sup>	4V 120-169 kW (163-230 PS)	93,00 mm	
<b>F4R</b>	<b>712, 713, 714, 715, 720, 730, 732, 736, 740, 741, 744, 746, 747, 770, 771, 780, 790, 791, 792, 820, 830</b>						
	09.1999 →	B (NA)	4	1998 cm <sup>3</sup>	4V 86-148 kW (117-200 PS)	93,00 mm	
<b>F4Rt 774 Euro 4</b>							
	05.2004 → 10.2009	B (A)	4	1998 cm <sup>3</sup>	4V 165 kW (224 PS)	9 93,00 mm	
<b>F4Rt 811 Euro 4</b>							
	09.2008 → 12.2015	B (A)	4	1998 cm <sup>3</sup>	4V 125 kW (170 PS)	9,5 93,00 mm	
40 021 6..							
	IN [2]	33,4 x 5,5 x 110,1	S - -	- 45° - -	1 - III	77 01 471 279 77 01 474 287	<b>539011</b>
	EX [2]	28,9 x 5,5 x 108,9	RA/S- -	- 45° - -	1 - III	77 01 471 280 77 01 473 101 77 01 474 286 77 01 478 130	<b>539014</b>
	IN/EX [4]	11,07 x 5,5 x 40,6	B1			77 00 109 151	<b>81-5136</b> (1)
	(1) ohne Ventilschaftabdichtung/without valve stem gasket/sans joint de tige de soupape/sin junta de vástago de válvula/без уплотнения стержня клапана						
	[8]	H 12 x 39 x 39				77 00 107 555	<b>50 006 437</b>
	[4]					77 00 107 556 82 00 115 605	<b>50 006 486</b>
<b>66</b>	<b>82,7</b>						
<b>F5R</b>	<b>700, 701, 740</b>						
	11.1999 → 09.2007	B (NA)	4	1998 cm <sup>3</sup>	4V 103 kW (140 PS)	10 93,00 mm	
	[8]	H 12 x 39 x 39				77 00 107 555	<b>50 006 437</b>
<b>67</b>	<b>82,7</b>						
<b>F4P</b>	<b>771, 772, 775</b>						
	03.2001 → 12.2007	B (NA)	4	1783 cm <sup>3</sup>	4V 85-89 kW (116-121 PS)	9,8 83,00 mm	
40 021 6..							
	IN [2]	33,4 x 5,5 x 110,1	S - -	- 45° - -	1 - III	77 01 471 279 77 01 474 287	<b>539011</b>
	EX [2]	28,9 x 5,5 x 108,9	RA/S- -	- 45° - -	1 - III	77 01 471 280 77 01 473 101 77 01 474 286 77 01 478 130	<b>539014</b>
	IN/EX [4]	11,07 x 5,5 x 40,6	B1			77 00 109 151	<b>81-5136</b> (1)
	(1) ohne Ventilschaftabdichtung/without valve stem gasket/sans joint de tige de soupape/sin junta de vástago de válvula/без уплотнения стержня клапана						
	[4]					77 00 107 556 82 00 115 605	<b>50 006 486</b>

					Reference	Item No.		
<b>68</b>		<b>82,7</b>						
<b>F4P</b>	<b>773</b>	03.2001 → 12.2007	B (NA)	4	1783 cm <sup>3</sup> 4V	85-89 kW (116-121 PS) 9,8	83,00 mm	
<b>F4R</b>	<b>400, 402, 403, 408, 410, 867</b>	04.2005 →	B (NA)	4	1998 cm <sup>3</sup> 4V	98-109 kW (133-148 PS)	93,00 mm	
<b>F4R</b>	<b>401, 414</b>		B	4	1998 cm <sup>3</sup> 4V	98 kW (133 PS)	93,00 mm	
<b>F4R</b>	<b>870, 872, 896, 897</b>	04.2005 →	B (LA)	4	1998 cm <sup>3</sup> 4V	125-140 kW (170-190 PS)	93,00 mm	
<b>F4R Euro 5</b>	<b>874</b>	11.2008 →	B (LA)	4	1998 cm <sup>3</sup> 4V	162-202 kW (220-275 PS) 8,5	93,00 mm	
<b>F4R Euro 4</b>	<b>832</b>	02.2006 → 12.2014	B (NA)	4	1998 cm <sup>3</sup> 4V	145-148 kW (197-201 PS) 11,5	93,00 mm	
<b>F4Rt 800 Euro 4</b>			B (A)	4	1998 cm <sup>3</sup> 4V	150 kW (204 PS)	93,00 mm	
40 021 6..								
	IN [2]	33,4 x 5,5 x 110,1	S - -	-	- 45° - -	1 - III	77 01 471 279 77 01 474 287	<b>539011</b>
	EX [2]	28,9 x 5,5 x 108,9	RA/S- -	-	- 45° - -	1 - III	77 01 471 280 77 01 473 101 77 01 474 286 77 01 478 130	<b>539014</b>
	IN/EX [4]	11,07 x 5.5 x 40,6	B1				77 00 109 151	<b>81-5136</b> (1)
(1) ohne Ventilschaftabdichtung/without valve stem gasket/sans joint de tige de soupape/sin junta de vástago de válvula/без уплотнения стержня клапана								
<b>69</b>		<b>82,7</b>						
<b>F4R</b>	<b>769</b>		B (LA)	4	1998 cm <sup>3</sup> 4V	120 kW (163 PS) 9,5:1	93,00 mm	
	IN [2]	33,4 x 5,5 x 110,1	S - -	-	- 45° - -	1 - III	77 01 471 279 77 01 474 287	<b>539011</b>
	EX [2]	28,9 x 5,5 x 108,9	RA/S- -	-	- 45° - -	1 - III	77 01 471 280 77 01 473 101 77 01 474 286 77 01 478 130	<b>539014</b>
	IN/EX [4]	11,07 x 5.5 x 40,6	B1				77 00 109 151	<b>81-5136</b> (1)
(1) ohne Ventilschaftabdichtung/without valve stem gasket/sans joint de tige de soupape/sin junta de vástago de válvula/без уплотнения стержня клапана								
	[8]	H 12 x 39 x 39					77 00 107 555	<b>50 006 437</b>
<b>70</b>		<b>82,7</b>						
<b>F7R</b>	<b>712</b>		B (NA)	4	1998 cm <sup>3</sup> 4V	110 kW (150 PS) 9,8:1	93,00 mm	
	IN [2]	33,0 x 7 x 107,2	S - -	-	- 45° - -	1 - III	77 00 865 550	<b>511011</b>
	EX [2]	28,4 x 7 x 108,8	A/S - -	-	- 45° - VS -	1 - III	77 00 865 551	<b>511012</b>
	[50]	Ø 7 mm					77 00 725 145	<b>KK-7H</b>
<b>71</b>		<b>82,7</b>						
<b>F4R</b>	<b>404, 405, 412, 416</b>	01.2011 →	AB (NA)	4	1998 cm <sup>3</sup> 4V	98-110 kW (133-150 PS)	93,00 mm	
Fortsetzung nächste Seite / continued on next page / suite page suivante / continuación página próxima / Продолжение на следующей странице								

**R**

					Reference	Item No.
IN [2]	33,4 x 5,5 x 110,1	S - -	- 45° - -	1 - III	77 01 471 279	<b>539011</b>
EX [2]	28,9 x 5,5 x 108,9	RA/S- -	- 45° - -	1 - III	77 01 474 287 77 01 471 280 77 01 473 101 77 01 474 286 77 01 478 130	<b>539014</b>
IN/EX [4]	11,07 x 5.5 x 40,6	B1			77 00 109 151	<b>81-5136</b> (1)

(1) ohne Ventilschaftabdichtung/without valve stem gasket/sans joint de tige de soupape/sin junta de vástago de válvula/без уплотнения стержня клапана

## 72

### 83

<b>N7Q</b>	<b>711</b>								
	07.1996 → 12.2000	B (NA)	4	1948 cm <sup>3</sup>	4V	100 kW	(136 PS)	10,5	90,00 mm
<b>N7Q</b>	<b>700, 704, 710</b>								
	06.1995 → 03.2001	B (NA)	4	1948 cm <sup>3</sup>	4V	100-102 kW	(136-139 PS)	10,5	90,00 mm

IN [2]	31,0 x 7 x 104,1	S - Cr -	- 45° - -	22 - III	74 38 610 007	<b>47145</b>
EX [2]	27,0 x 7 x 103,3	A/S - Cr -	- 45° - VS -	22 - III	74 38 610 008	<b>47130</b>
[50]	Ø 7 mm					<b>MK-7H</b>
IN/EX [6]	11,99 x 7 x 45,0	G1				<b>81-47105</b>
[8]	H 32 x 26				7439207830	<b>50 007 605</b>

## 73

### 84

<b>M9R</b>	<b>610, 615, 630, 700, 721, 722, 724, 740, 742, 744, 746, 748, 750, 760, 761, 762, 763, 800, 802, 804, 809, 814, 815, 816, 817, 820, 824, 830, 832, 833</b>								
	08.2005 →	D (LA)	4	1995 cm <sup>3</sup>	4V	66-132 kW	(90-180 PS)		90,00 mm
<b>M9R Euro 4</b>	<b>786, 805</b>								
	08.2006 →	D (LA)	4	1995 cm <sup>3</sup>	4V	66-110 kW	(90-150 PS)		90,00 mm

40 262 6..., 97 597 7..

IN [2]	27,7 x 6 x 104,0	S - -	- 45° - -	22 - III	77 01 476 596	<b>539024</b>
EX [2]	26,0 x 6 x 103,8	A/S - -	- 45° - -	22 - III	77 01 476 595	<b>539025</b>
[50]	Ø 6 mm					<b>MK-6H</b>
IN/EX [4]	11,05 x 6 x 42,4	B1				<b>81-51002</b>
IN/EX [4]	11,25 x 6 x 42,4	B1				<b>81-51003</b>
	AS				82 00 456 103	<b>50 007 709</b> (1)
	ES				82 00 827 922 82 00 619 361 82 00 827 912	<b>50 007 710</b> (1)
	(1) Schalenhartguss/chilled cast iron/pièce moulée trempée en surface/fundición en coquilla/Отливка с отбелнным поверхностным слоем					
[8]	H 12 x 34,6 x 34,6				77 01 062 312	<b>50 006 432</b>
[4]					77 01 062 311	<b>50 007 711</b>

## 74

### 84

<b>M9R</b>	<b>806, 812</b>								
	01.2006 →	D (LA)	4	1995 cm <sup>3</sup>	4V	127 kW	(173 PS)		90,00 mm

Fortsetzung nächste Seite / continued on next page / suite page suivante / continuación página próxima / Продолжение на следующей странице

					Reference	Item No.
IN [2] EX [2]	27,7 x 6 x 104,0 26,0 x 6 x 103,8	S - - A/S - -	- 45° - - - 45° - -	22 - III 22 - III	77 01 476 596 77 01 476 595	<b>539024</b> <b>539025</b>
[50]	Ø 6 mm					<b>MK-6H</b>
IN/EX [4]	11,05 x 6 x 42,4	B1				<b>81-51002</b> <small>NEW</small>
	AS ES				82 00 456 103 82 00 827 922 82 00 619 361 82 00 827 912	<b>50 007 709</b> (1) <b>50 007 710</b> (1)
	(1) Schalenhartguss/chilled cast iron/pièce moulée trempée en surface/fundición en coquilla/Отливка с отбеленным поверхностным слоем					
[8]	H 12 x 34,6 x 34,6				77 01 062 312	<b>50 006 432</b>
[4]					77 01 062 311	<b>50 007 711</b>

<b>75</b>		<b>84</b>
<b>M9R Euro 4</b>	<b>859</b>	
	01.2006 →	D (LA) 4 1995 cm <sup>3</sup> 4V 127 kW (173 PS) 15,7 90,00 mm
<b>M9R</b>	<b>828, 846, 850, 854, 857, 858</b>	
	01.2006 →	D (LA) 4 1995 cm <sup>3</sup> 4V 96-131 kW (131-178 PS) 15,7 90,00 mm
97 597 7..		

IN [2] EX [2]	27,7 x 6 x 104,0 26,0 x 6 x 103,8	S - - A/S - -	- 45° - - - 45° - -	22 - III 22 - III	77 01 476 596 77 01 476 595	<b>539024</b> <b>539025</b>
[50]	Ø 6 mm					<b>MK-6H</b>
IN/EX [4]	11,05 x 6 x 42,4	B1				<b>81-51002</b> <small>NEW</small>
	AS ES				82 00 456 103 82 00 827 922 82 00 619 361 82 00 827 912	<b>50 007 709</b> (1) <b>50 007 710</b> (1)
	(1) Schalenhartguss/chilled cast iron/pièce moulée trempée en surface/fundición en coquilla/Отливка с отбеленным поверхностным слоем					
[8]	H 12 x 34,6 x 34,6				77 01 062 312	<b>50 006 432</b>

<b>76</b>		<b>84</b>
<b>M9R Euro 5</b>	<b>692</b>	
	08.2006 →	D (A) 4 1995 cm <sup>3</sup> 4V 84 kW (114 PS) 15,5 90,00 mm
<b>M9R</b>	<b>B 610, C 613, C 615, C 830, G 832</b>	
		D (LA) 4 1995 cm <sup>3</sup> 4V 110-118 kW (150-160 PS) 90,00 mm
<b>M9R Euro 4</b>	<b>A 700, B 721</b>	
		D (A) 4 1995 cm <sup>3</sup> 4V 110 kW (150 PS) 15,7:1 90,00 mm
<b>M9Rk 800 Euro 4</b>		D (A) 4 1995 cm <sup>3</sup> 4V 127 kW (173 PS) 16,0:1 90,00 mm
<b>M9Rk 802 Euro 4</b>		D (A) 4 1995 cm <sup>3</sup> 4V 96-110 kW (131-150 PS) 16,0:1 90,00 mm
<b>M9Rk 805 Euro 4</b>		D (A) 4 1995 cm <sup>3</sup> 4V 110 kW (150 PS) 16,0:1 90,00 mm
<b>M9Rk 816 Euro 4</b>		D (A) 4 1995 cm <sup>3</sup> 4V 131 kW (178 PS) 16:1 90,00 mm
97 597 7..		

Fortsetzung nächste Seite / continued on next page / suite page suivante / continuación página próxima / Продолжение на следующей странице

					Reference	Item No.
	IN/EX [4] 11,05 x 6 x 42,4	B1				<b>81-51002</b> <small>NEW</small>
	IN/EX [4] 11,25 x 6 x 42,4	B1				<b>81-51003</b> <small>NEW</small>
	AS				82 00 456 103 82 00 827 922	<b>50 007 709</b> (1)
	ES				82 00 619 361 82 00 827 912	<b>50 007 710</b> (1)
	(1) Schalenhartguss/chilled cast iron/pièce moulée trempée en surface/fundición en coquilla/Отливка с отбеленным поверхностным слоем					

## 77 84

<b>M9R</b>	<b>782</b>							
	08.2006 →	D (LA)	4	1995 cm <sup>3</sup>	4V	66-84 kW	(90-114 PS)	15,7 90,00 mm
<b>M9R Euro 4</b>	<b>780</b>							
	08.2006 →	D (LA)	4	1995 cm <sup>3</sup>	4V	66-84 kW	(90-114 PS)	16 90,00 mm

	IN [2] EX [2]	27,7 x 6 x 104,0 26,0 x 6 x 103,8	S - - A/S - -	- 45° - - - 45° - -	22 - III 22 - III	77 01 476 596 77 01 476 595	<b>539024</b> <b>539025</b>
	[50]	∅ 6 mm					<b>MK-6H</b>
	IN/EX [4] IN/EX [4]	11,05 x 6 x 42,4 11,25 x 6 x 42,4	B1 B1				<b>81-51002</b> <small>NEW</small> <b>81-51003</b> <small>NEW</small>
	AS					82 00 456 103 82 00 827 922	<b>50 007 709</b> (1)
	ES					82 00 381 578 82 00 825 144	<b>50 007 854</b>
	(1) Schalenhartguss/chilled cast iron/pièce moulée trempée en surface/fundición en coquilla/Отливка с отбеленным поверхностным слоем						
	[8]	H 12 x 34,6 x 34,6				77 01 062 312	<b>50 006 432</b>
	[4]					77 01 062 311	<b>50 007 711</b>

## 78 84

<b>M9R</b>	<b>754, 808</b>							
	10.2007 → 12.2015	D (LA)	4	1995 cm <sup>3</sup>	4V	110 kW	(150 PS)	15,7 90,00 mm

	AS					82 00 456 103 82 00 827 922	<b>50 007 709</b> (1)
	ES					82 00 619 361 82 00 827 912	<b>50 007 710</b> (1)
	(1) Schalenhartguss/chilled cast iron/pièce moulée trempée en surface/fundición en coquilla/Отливка с отбеленным поверхностным слоем						
	[4]					77 01 062 311	<b>50 007 711</b>

## 79 84

<b>M9R Euro 4</b>	<b>856, 862, 865, 866</b>							
	09.2008 →	D (LA)	4	1995 cm <sup>3</sup>	4V	110-127 kW	(150-173 PS)	15,7 90,00 mm
<b>M9R</b>	<b>844, 845, 849, 855, 864</b>							
	10.2007 →	D (LA)	4	1995 cm <sup>3</sup>	4V	110-127 kW	(150-173 PS)	90,00 mm

	IN [2] EX [2]	27,7 x 6 x 104,0 26,0 x 6 x 103,8	S - - A/S - -	- 45° - - - 45° - -	22 - III 22 - III	77 01 476 596 77 01 476 595	<b>539024</b> <b>539025</b>
	[50]	∅ 6 mm					<b>MK-6H</b>

Fortsetzung nächste Seite / continued on next page / suite page suivante / continuación página próxima / Продолжение на следующей странице



					Reference	Item No.
	IN/EX [4] 11,05 x 6 x 42,4 IN/EX [4] 11,25 x 6 x 42,4	B1 B1				<b>81-51002</b> <b>81-51003</b>
	AS ES  (1) Schalenhartguss/chilled cast iron/pièce moulée trempée en surface/fundición en coquilla/Отливка с отбеленным поверхностным слоем				82 00 456 103 82 00 827 922 82 00 619 361 82 00 827 912	<b>50 007 709</b> (1) <b>50 007 710</b> (1)
	[8] H 12 x 34,6 x 34,6				77 01 062 312	<b>50 006 432</b>

<b>80</b>		<b>84</b>			
<b>M9R</b>	<b>834, 835, 836, 838</b> 09.2008 →	D (LA) 4 1995 cm <sup>3</sup> 4V 110 kW (150 PS) 15,7 90,00 mm			
<b>M9R Euro 5</b>	<b>891</b>	D (LA) 6 2998 cm <sup>3</sup> 4V 173 kW (235 PS) 15,7:1 90,20 mm			
	IN [2] EX [2] 27,7 x 6 x 104,0 26,0 x 6 x 103,8	S - - A/S - - - 45° - - - 45° - - 22 - III 22 - III	77 01 476 596 77 01 476 595	<b>539024</b> <b>539025</b>	
	[50] Ø 6 mm			<b>MK-6H</b>	
	IN/EX [4] 11,05 x 6 x 42,4	B1			<b>81-51002</b>
	[8] H 12 x 34,6 x 34,6			77 01 062 312	<b>50 006 432</b>

<b>81</b>		<b>84</b>			
<b>M9R</b>	<b>756, D 833</b> 12.2013 →	D (LA) 4 1995 cm <sup>3</sup> 4V 96-110 kW (131-150 PS) 90,00 mm			
	AS ES  (1) Schalenhartguss/chilled cast iron/pièce moulée trempée en surface/fundición en coquilla/Отливка с отбеленным поверхностным слоем			82 00 456 103 82 00 827 922 82 00 619 361 82 00 827 912	<b>50 007 709</b> (1) <b>50 007 710</b> (1)

<b>82</b>		<b>84</b>			
<b>M9R</b>	<b>784</b> 40 262 6..	D (LA) 4 1995 cm <sup>3</sup> 4V 84 kW (114 PS) 90,00 mm			
	ES			82 00 381 578 82 00 825 144	<b>50 007 854</b>

<b>83</b>		<b>84</b>			
<b>M9Ra 742 Euro 4</b>		D (A) 4 1995 cm <sup>3</sup> 4V 96-110 kW (131-150 PS) 16,0:1 90,00 mm			
	IN/EX [4] IN/EX [4] 11,05 x 6 x 42,4 11,25 x 6 x 42,4	B1 B1			<b>81-51002</b> <b>81-51003</b>

<b>84</b>		<b>85</b>
<b>M9T</b>	<b>678, 680</b> 02.2010 →	D (A) 4 2298 cm <sup>3</sup> 4V 92-107 kW (125-146 PS) 16 101,30 mm
<b>M9T Euro 5</b>	<b>670, 672, 686, 690, 698</b> 02.2010 →	D (A) 4 2298 cm <sup>3</sup> 4V 74-110 kW (101-150 PS) 16 101,30 mm
<b>M9T Euro 4</b>	<b>676, 692, 694, 696</b> 02.2010 →	D (A) 4 2298 cm <sup>3</sup> 4V 74-110 kW (101-150 PS) 16 101,30 mm
97 504 6..		

Fortsetzung nächste Seite / continued on next page / suite page suivante / continuación página próxima / Продолжение на следующей странице

					Reference	Item No.	
	IN [2] EX [2]	27,7 x 6 x 104,0 26,0 x 6 x 103,8	S - - A/S - -	- 45° - - - 45° - -	22 - III 22 - III	77 01 476 596 77 01 476 595	<b>539024</b> <b>539025</b>
	[50]	∅ 6 mm					<b>MK-6H</b>
	IN/EX [4]	11,05 x 6 x 42,4	B1				<b>81-51002</b> <small>NEW</small>
		AS ES			82 00 456 103 82 00 827 922 82 00 619 361 82 00 827 912	<b>50 007 709</b> (1) <b>50 007 710</b> (1)	
	(1)	Schalenhartguss/chilled cast iron/pièce moulée trempée en surface/fundición en coquilla/Отливка с отбелсным поверхностным слоем					
	[8]	H 12 x 34,6 x 34,6			77 01 062 312	<b>50 006 432</b>	
	[4]				77 01 062 311	<b>50 007 711</b>	

## 85

<b>M9T Euro 5</b>	<b>700, 702, 880, 890</b>	02.2010 →	D (A)	4	2298 cm <sup>3</sup>	4V	74-120 kW	(100-163 PS)	16	101,30 mm
<b>M9T Euro 4</b>	<b>882</b>	02.2010 →	D (A)	4	2298 cm <sup>3</sup>	4V	92-96 kW	(125-131 PS)		101,30 mm
<b>M9T Euro 4/5</b>	<b>870, 872</b>	02.2010 →	D (A)	4	2298 cm <sup>3</sup>	4V	74-92 kW	(100-125 PS)		101,30 mm
<b>M9T</b>	<b>892</b>		D	4	2298 cm <sup>3</sup>	4V			16:1	101,30 mm

97 504 6..

	IN [2] EX [2]	27,7 x 6 x 104,0 26,0 x 6 x 103,8	S - - A/S - -	- 45° - - - 45° - -	22 - III 22 - III	77 01 476 596 77 01 476 595	<b>539024</b> <b>539025</b>
	[50]	∅ 6 mm					<b>MK-6H</b>
	IN/EX [4]	11,05 x 6 x 42,4	B1				<b>81-51002</b> <small>NEW</small>
		AS ES			82 00 456 103 82 00 827 922 82 00 619 361 82 00 827 912	<b>50 007 709</b> (1) <b>50 007 710</b> (1)	
	(1)	Schalenhartguss/chilled cast iron/pièce moulée trempée en surface/fundición en coquilla/Отливка с отбелсным поверхностным слоем					
	[8]	H 12 x 34,6 x 34,6			77 01 062 312	<b>50 006 432</b>	

## 86

<b>M9T Euro 4</b>	<b>896</b>	02.2010 →	D (A)	4	2298 cm <sup>3</sup>	4V	92-110 kW	(125-150 PS)	16	101,30 mm
<b>M9T Euro 5</b>	<b>898</b>	02.2010 →	D (A)	4	2298 cm <sup>3</sup>	4V	92-110 kW	(125-150 PS)	16	101,30 mm
<b>M9T Euro 4/5</b>	<b>706</b>	02.2010 →	D (A)	4	2299 cm <sup>3</sup>	4V	107-125 kW	(145-170 PS)	16	101,30 mm

97 504 6..

	IN [2] EX [2]	27,7 x 6 x 104,0 26,0 x 6 x 103,8	S - - A/S - -	- 45° - - - 45° - -	22 - III 22 - III	77 01 476 596 77 01 476 595	<b>539024</b> <b>539025</b>
--	------------------	--------------------------------------	------------------	------------------------	----------------------	--------------------------------	--------------------------------

Fortsetzung nächste Seite / continued on next page / suite page suivante / continuación página próxima / Продолжение на следующей странице

					Reference	Item No.
[50]	Ø 6 mm					<b>MK-6H</b>
IN/EX [4]	11,05 x 6 x 42,4	B1				<b>81-51002</b>
IN/EX [4]	11,25 x 6 x 42,4	B1				<b>81-51003</b>
	AS				82 00 456 103	<b>50 007 709</b> (1)
	ES				82 00 827 922	
					82 00 619 361	<b>50 007 710</b> (1)
					82 00 827 912	
	(1) Schalenhartguss/chilled cast iron/pièce moulée trempée en surface/fundición en coquilla/Отливка с отбеленным поверхностным слоем					
[8]	H 12 x 34,6 x 34,6				77 01 062 312	<b>50 006 432</b>
<b>87</b>	<b>85</b>					
<b>M9T</b>	<b>260</b>					
	09.2017 →	D (LA)	4	2298 cm <sup>3</sup>	4V 120-140 kW (163-190 PS)	16 101,30 mm
	AS				82 00 456 103	<b>50 007 709</b> (1)
	ES				82 00 827 922	
					82 00 619 361	<b>50 007 710</b> (1)
					82 00 827 912	
	(1) Schalenhartguss/chilled cast iron/pièce moulée trempée en surface/fundición en coquilla/Отливка с отбеленным поверхностным слоем					
<b>88</b>	<b>85</b>					
<b>M9T</b>	<b>606</b>					
		D	4	2298 cm <sup>3</sup>	4V	16:1 101,30 mm
	97 504 6..					
IN [2]	27,7 x 6 x 104,0	S - -	- 45° - -	22 - III	77 01 476 596	<b>539024</b>
EX [2]	26,0 x 6 x 103,8	A/S - -	- 45° - -	22 - III	77 01 476 595	<b>539025</b>
[50]	Ø 6 mm					<b>MK-6H</b>
IN/EX [4]	11,05 x 6 x 42,4	B1				<b>81-51002</b>
[8]	H 12 x 34,6 x 34,6				77 01 062 312	<b>50 006 432</b>
<b>89</b>	<b>86</b>					
<b>852</b>	<b>710, 720, 750</b>					
	03.1980 → 06.1994	D (NA)	4	2068 cm <sup>3</sup>	2V 43-49 kW (58-67 PS)	21,5 89,00 mm
<b>852</b>		D (NA)	4	2068 cm <sup>3</sup>	2V 47 kW (64 PS)	21,5 89,00 mm
<b>J8S</b>	<b>610, 612, 708, 738, 772, 814</b>					
	04.1984 →	D (LA)	4	2068 cm <sup>3</sup>	2V 63-66 kW (86-90 PS)	89,00 mm
<b>J8S</b>	<b>240, 604, 702, 712, 714, 742, 746, 760, 774, 776, 778, 786, 788, 890</b>					
	11.1981 →	D (A)	4	2068 cm <sup>3</sup>	2V 63-66 kW (86-90 PS)	89,00 mm
<b>J8S</b>	<b>330, 600, 620, 704, 706, 711, 736, 740, 758, 784</b>					
	05.1979 → 07.1998	D (NA)	4	2068 cm <sup>3</sup>	2V 44-53 kW (60-72 PS)	89,00 mm
	90 436 6..					
IN [2]	40,3 x 8 x 111,6	S - -	- 45° - VS -	1 - III	77 00 663 545	<b>515319</b>
					77 00 692 312	
					77 01 461 338	
[50]	Ø 8 mm					<b>KK-8H</b>

**R**

					Reference	Item No.	
<b>90</b>	<b>87</b>						
<b>G8T</b>	<b>706, 752, 790, 792, 794</b>						
	11.1993 →	D (NA)	4	2188 cm <sup>3</sup>	3V	61 kW (83 PS)	92,00 mm
[50]	Ø 7 mm						<b>MK-7H</b>
[12]	H 15 x 42,8 x 42,8					77 00 858 606	<b>50 006 431</b>
[4]						77 00 856 805	<b>50 006 429</b>
<b>91</b>	<b>87</b>						
<b>G8T</b>	<b>760</b>						
	03.1996 → 03.2001	D (LA)	4	2188 cm <sup>3</sup>	3V	83 kW (113 PS) 22	92,00 mm
[50]	Ø 7 mm						<b>MK-7H</b>
IN [4] EX [4]	12,06 x 7 x 42,0 12,06 x 7 x 49,0	B1 B1					<b>81-5133</b> <b>81-5134</b>
						77 00 869 325	<b>50 006 188</b> (1)
	(1) Schalenhartguss/chilled cast iron/pièce moulée trempée en surface/fundición en coquilla/Отливка с отбелсным поверхностным слоем						
[12]	H 15 x 42,8 x 42,8					77 00 858 606	<b>50 006 431</b>
<b>92</b>	<b>87</b>						
<b>G8T</b>	<b>716</b>						
	11.1996 → 10.2000	D (A)	4	2188 cm <sup>3</sup>	3V	83 kW (113 PS) 22	92,00 mm
<b>G8T</b>	<b>740</b>						
	07.1996 → 12.2000	D (LA)	4	2188 cm <sup>3</sup>	3V	83 kW (113 PS) 22	92,00 mm
[50]	Ø 7 mm						<b>MK-7H</b>
						77 00 869 325	<b>50 006 188</b> (1)
	(1) Schalenhartguss/chilled cast iron/pièce moulée trempée en surface/fundición en coquilla/Отливка с отбелсным поверхностным слоем						
[12]	H 15 x 42,8 x 42,8					77 00 858 606	<b>50 006 431</b>
[4]						77 00 856 805	<b>50 006 429</b>
<b>93</b>	<b>87</b>						
<b>G8T</b>	<b>714</b>						
	11.1996 → 10.2000	D (LA)	4	2188 cm <sup>3</sup>	3V	83 kW (113 PS) 22	92,00 mm
[50]	Ø 7 mm						<b>MK-7H</b>
						77 00 869 325	<b>50 006 188</b> (1)
	(1) Schalenhartguss/chilled cast iron/pièce moulée trempée en surface/fundición en coquilla/Отливка с отбелсным поверхностным слоем						
Fortsetzung nächste Seite / continued on next page / suite page suivante / continuación página próxima / Продолжение на следующей странице							

					Reference	Item No.
[12]	H 15 x 42,8 x 42,8				77 00 858 606	50 006 431

<b>94</b>		<b>87</b>	
<b>G9T Euro 4</b>	<b>600, 605, 606, 645</b>		
	04.2004 →	D (A) 4	2188 cm <sup>3</sup> 4V 78-102 kW (106-139 PS) 18 92,00 mm
<b>G9T</b>	<b>607, 642, 700, 703, 706, 707, 710, 712, 722, 750</b>		
	07.2000 →	D (LA) 4	2188 cm <sup>3</sup> 4V 66-110 kW (90-150 PS) 92,00 mm
<b>G9T</b>	<b>720</b>		
	09.2000 →	D (A) 4	2188 cm <sup>3</sup> 4V 66 kW (90 PS) 18 92,00 mm
<b>G9T Euro 3</b>	<b>702</b>		
	10.2001 →	D (A) 4	2188 cm <sup>3</sup> 4V 83-110 kW (113-150 PS) 18 92,00 mm
<b>G9T Euro 3</b>	<b>742, 743</b>		
	11.2002 → 08.2006	D (LA) 4	2188 cm <sup>3</sup> 4V 110 kW (150 PS) 18 92,00 mm

	IN [2] EX [2]	30,6 x 6 x 123,2 29,5 x 6 x 123,0	S - - A/S - -	- 45° - - - 45° - -	22 - III 22 - III	77 01 472 669 77 01 472 670	<b>539020</b> <b>539021</b>
	IN/EX [4]	11,04 x 6 x 50,0	B1			82 00 562 080	<b>81-5332</b>
	ES AS AS ES (1) (ST) (2) gegossene Version / cast Version / version coule / versión fundida / литая версия					82 00 019 181 82 00 019 183 82 00 019 183 82 00 019 181	<b>50 007 118</b> (1) <b>50 007 123</b> (1) <b>50 007 124</b> (2) <b>50 007 126</b> (2)

<b>95</b>		<b>88</b>	
<b>112</b>	02.1975 → 08.1978	B (NA) 6	2664 cm <sup>3</sup> 2V 92-96 kW (125-131 PS) 8,65 73,00 mm
<b>140</b>	10.1978 → 12.1983	B (NA) 6	2664 cm <sup>3</sup> 2V 105 kW (143 PS) 9,2 73,00 mm
<b>144.01</b>		B (NA) 6	2664 cm <sup>3</sup> 2V 85-96 kW (116-131 PS) 9,2:1 73,00 mm
<b>829</b>	<b>710</b>		
	10.1980 → 10.1985	B (NA) 4	1995 cm <sup>3</sup> 2V 81 kW (110 PS) 9,2 82,00 mm
<b>J5R</b>	<b>A7</b>		
	01.1983 →	B	4 1995 cm <sup>3</sup> 2V 61 kW (83 PS) 9,2:1 82,00 mm
<b>J5R</b>	<b>716, 718, 722, 726, 728</b>		
	03.1980 → 12.2001	B (NA) 4	1995 cm <sup>3</sup> 2V 57-81 kW (78-84 PS) 9,2 82,00 mm
<b>J6R</b>	<b>234, 236, 706, 707, 710, 712, 713, 714, 715, 716, 726, 734, 758, 759, 760, 762, 763, 792, 793</b>		
	10.1980 → 10.1993	B (NA) 4	1995 cm <sup>3</sup> 2V 69-81 kW (101-110 PS) 82,00 mm
<b>J7R</b>	<b>756</b>		
	02.1990 → 10.1992	B (A) 4	1995 cm <sup>3</sup> 2V 119 kW (162 PS) 8,5 82,00 mm
<b>J7R</b>	<b>720, 726, 740, 754</b>		
	06.1988 → 08.1994	B (NA) 4	1995 cm <sup>3</sup> 3V 98-103 kW (133-140 PS) 9,3 82,00 mm
<b>J7R</b>	<b>722, 723, 732, 733, 738, 739, 746, 747, 750, 751, 760</b>		
	03.1986 →	B (NA) 4	1995 cm <sup>3</sup> 2V 77-99 kW (105-135 PS) 82,00 mm
<b>J7R</b>	<b>752</b>		
	04.1987 → 03.1990	B (A) 4	1995 cm <sup>3</sup> 2V 129 kW (175 PS) 8 82,00 mm
<b>J7R</b>	<b>730</b>		
		B	4 1995 cm <sup>3</sup> 2V 88 kW (120 PS) 10:1 82,00 mm
<b>J7R</b>	<b>768</b>		
	01.1991 → 10.1996	B (NA) 4	1995 cm <sup>3</sup> 2V 76 kW (103 PS) 9,2 82,00 mm
<b>J7R</b>	<b>721</b>		
	06.1988 → 12.1993	B (NA) 4	1995 cm <sup>3</sup> 3V 103 kW (140 PS) 9,3 82,00 mm
<b>J7T</b>	<b>766, 767</b>		
		B	4 2165 cm <sup>3</sup> 3V 101-103 kW (137-140 PS) 9,2:1 89,00 mm
<b>J7T</b>	<b>600, 718, 732, 733, 755, 762, 770, 772, 773, 776, 788</b>		
	10.1983 → 05.1999	B (NA) 4	2165 cm <sup>3</sup> 2V 59-91 kW (91-116 PS) 89,00 mm
<b>J7T</b>	<b>706, 707, 708, 714, 715, 719, 730, 731, 736, 754, 756, 763, 780, 782</b>		
	08.1980 →	B (NA) 4	2165 cm <sup>3</sup> 2V 67-91 kW (91-124 PS) 89,00 mm
<b>J7T</b>	<b>760</b>		
	02.1994 → 07.1996	B (NA) 4	2165 cm <sup>3</sup> 3V 101 kW (137 PS) 9,2 89,00 mm
<b>Z7V</b>	<b>709, 711</b>		
	04.1984 → 08.1989	B (NA) 6	2664 cm <sup>3</sup> 2V 104 kW (141 PS) 9,2 73,00 mm

Fortsetzung nächste Seite / continued on next page / suite page suivante / continuación página próxima / Продолжение на следующей странице

					Reference	Item No.
IN [2] EX [2]	43,9 x 8 x 112,0 37,0 x 8 x 111,3	S - - A/S - Cr -	- 30° - - - 45° - VS -	1 - III 1 - III	77 01 460 147 79 00 000 681	<b>536226</b> <b>538930</b>
[50]	∅ 8 mm					<b>KK-8H</b>
<b>96</b>	<b>89</b>					
<b>G9U Euro 3</b>	<b>720, 724, 730, 750, 754</b>					
	03.2001 →	D (LA)	4	2463 cm <sup>3</sup>	4V 73-99 kW (99-135 PS)	99,00 mm
<b>G9U Euro 4</b>	<b>630, 632, 650</b>					
	08.2006 →	D (LA)	4	2463 cm <sup>3</sup>	4V 74-107 kW (101-146 PS)	99,00 mm
40 079 6..						
IN [2] EX [2]	30,6 x 6 x 123,2 29,5 x 6 x 123,0	S - - A/S - -	- 45° - - - 45° - -	22 - III 22 - III	77 01 472 669 77 01 472 670	<b>539020</b> <b>539021</b>
IN/EX [4]	11,04 x 6 x 50,0	B1			82 00 562 080	<b>81-5332</b>
	ES AS AS ES				82 00 019 181 82 00 019 183 82 00 019 183 82 00 019 181	<b>50 007 118</b> (1) <b>50 007 123</b> (1) <b>50 007 124</b> (2) <b>50 007 126</b> (2)
	(1) (ST)					
	(2) gegossene Version / cast Version / version coule / versión fundida / литая версия					
<b>97</b>	<b>91</b>					
<b>Z7W</b>	<b>700, 706, 707, 712, 713, 717</b>					
	06.1987 → 10.1996	B (NA)	6	2849 cm <sup>3</sup>	2V 110-115 kW (150-156 PS) 9,5	73,00 mm
<b>Z7W</b>	<b>701, 702, 709</b>					
	06.1986 →	B (NA)	6	2849 cm <sup>3</sup>	2V 100-115 kW (136-156 PS)	73,00 mm
IN [2] EX [2]	43,9 x 8 x 112,0 37,0 x 8 x 111,3	S - - A/S - Cr -	- 30° - - - 45° - VS -	1 - III 1 - III	77 01 460 147 79 00 000 681	<b>536226</b> <b>538930</b>
[50]	∅ 8 mm					<b>KK-8H</b>
<b>98</b>	<b>93</b>					
<b>8140.61.2300</b>	08.1980 → 07.1998	D (NA)	4	2445 cm <sup>3</sup>	2V 52 kW (71 PS) 21	90,00 mm
<b>8140.61.240</b>	03.1980 → 03.2001	D (A)	4	2445 cm <sup>3</sup>	2V 51 kW (69 PS) 21:1	90,00 mm
IN [2] EX [2]	41,0 x 8 x 120,8 34,5 x 8 x 122,0	S - Cr - A/S - Cr -	- 30° - - - 45° - -	9 - III 9 - III	77 01 030 863 77 01 462 678 77 01 463 603	<b>171120</b> <b>17063</b>
[50] [50]	∅ 8 mm ∅ 8 mm				50 01 001 245	<b>RK-8</b> <b>RK-8H</b>
IN/EX [4]	13,07 x 8.02 x 60,0	G1			50 01 001 581	<b>81-17114</b> (1)
	(1) ohne Ventilschaftabdichtung/without valve stem gasket/sans joint de tige de soupape/sin junta de vástago de válvula/без уплотнения стержня клапана					



					Reference	Item No.			
<b>99</b>		<b>93</b>							
<b>S8U</b>	<b>720, 722, 730, 731, 748</b>	07.1980 →	D (NA)	4	2445 cm <sup>3</sup>	2V	50-55 kW (68-75 PS)	90,00 mm	
<b>S8U</b>	<b>742, 750, 752, 758, 780</b>	03.1989 → 03.2001	D (NA)	4	2499 cm <sup>3</sup>	2V	55-58 kW (75-79 PS)	22 92,00 mm	
<b>S8U</b>	<b>762</b>	12.1992 → 07.1996	D (LA)	4	2499 cm <sup>3</sup>	2V	83 kW (113 PS)	21 92,00 mm	
<b>S8U</b>	<b>770</b>	07.1998 → 01.2001	D (A)	4	2499 cm <sup>3</sup>	2V	59 kW (80 PS)	22,5 92,00 mm	
<b>S9U</b>			D (A)	4	2499 cm <sup>3</sup>	2V	55 kW (75 PS)	17,5:1 92,00 mm	
<b>S9U</b>	<b>700, 702, 704, 714, 740</b>	08.1989 →	D (A)	4	2499 cm <sup>3</sup>	2V	69-72 kW (94-98 PS)	92,00 mm	
	IN [2]	41,0 x 8 x 120,8	S - Cr -		- 30° -		9 - III	77 01 030 863 77 01 462 678 77 01 463 603	<b>171120</b>
	[50] [50]	∅ 8 mm ∅ 8 mm						50 01 001 245	<b>RK-8</b> <b>RK-8H</b>
	IN/EX [4]	13,07 x 8.02 x 60,0	G1					50 01 001 581	<b>81-17114</b> (1)
	(1)	ohne Ventilschaftabdichtung/without valve stem gasket/sans joint de tige de soupape/sin junta de vástago de válvula/без уплотнения стержня клапана							
<b>100</b>		<b>93</b>							
<b>8140.27.2500</b>		08.1989 → 07.1998	D (A)	4	2499 cm <sup>3</sup>	2V	69 kW (94 PS)	92,00 mm	
<b>8140.27.2510</b>		08.1989 → 07.1998	D (A)	4	2499 cm <sup>3</sup>	2V	69 kW (94 PS)	92,00 mm	
<b>8140.27.2530 IDS Euro 1</b>			D (A)	4	2499 cm <sup>3</sup>	2V	71-78 kW (96-106 PS)	18,5:1 92,00 mm	
<b>8140.27.2580</b>		08.1989 → 07.1998	D (A)	4	2499 cm <sup>3</sup>	2V	72 kW (98 PS)	22:1 92,00 mm	
<b>8140.27.2582</b>		01.1986 → 07.1996	D (A)	4	2499 cm <sup>3</sup>	2V	74-79 kW (101-107 PS)	18,5:1 92,00 mm	
<b>8140.47.2785 Euro 1</b>		09.1980 →	D (A)	4	2499 cm <sup>3</sup>	2V	85 kW (116 PS)	18,5:1 92,00 mm	
	IN [2]	41,0 x 8 x 120,8	S - Cr -		- 30° -		9 - III	77 01 030 863 77 01 462 678 77 01 463 603	<b>171120</b>
	EX [2]	34,5 x 8 x 122,0	A/S - Cr -		- 45° -		9 - III		<b>17063</b>
	EX [2]	36,0 x 8 x 122,0	A/S - Cr -		- 45° -		9 - III		<b>171055</b>
	[50] [50]	∅ 8 mm ∅ 8 mm						50 01 001 245	<b>RK-8</b> <b>RK-8H</b>
	IN/EX [4]	13,02 x 8.02 x 56,0	G1						<b>81-17116</b>
	IN/EX [4]	13,07 x 8.02 x 56,0	G1						<b>81-17115</b>
	IN/EX [4]	13,07 x 8.02 x 60,0	G1					50 01 001 581	<b>81-17114</b> (1)
	IN/EX [4]	13,12 x 8 x 56,0	G1						<b>81-5611</b>
	(1)	ohne Ventilschaftabdichtung/without valve stem gasket/sans joint de tige de soupape/sin junta de vástago de válvula/без уплотнения стержня клапана							
	[8]	M 44 x 32							<b>50 006 180</b>
<b>101</b>		<b>93</b>							
<b>8140.21.235</b>		01.1986 → 06.1994	D (A)	4	2445 cm <sup>3</sup>	2V	68 kW (92 PS)	18:1 90,00 mm	
	IN [2]	41,0 x 8 x 120,8	S - Cr -		- 30° -		9 - III	77 01 030 863 77 01 462 678 77 01 463 603	<b>171120</b>
	EX [2]	34,5 x 8 x 122,0	A/S - Cr -		- 45° -		9 - III		<b>17063</b>
	[50] [50]	∅ 8 mm ∅ 8 mm						50 01 001 245	<b>RK-8</b> <b>RK-8H</b>
Fortsetzung nächste Seite / continued on next page / suite page suivante / continuación página próxima / Продолжение на следующей странице									

					Reference	Item No.
	IN/EX [4] 13,02 x 8.02 x 56,0 IN/EX [4] 13,07 x 8.02 x 56,0 IN/EX [4] 13,07 x 8.02 x 60,0 IN/EX [4] 13,12 x 8 x 56,0	G1 G1 G1 G1			50 01 001 581	<b>81-17116</b> <b>81-17115</b> <b>81-17114</b> (1) <b>81-5611</b>
(1) ohne Ventilschaftabdichtung/without valve stem gasket/sans joint de tige de soupape/sin junta de vástago de válvula/без уплотнения стержня клапана						
<b>102</b>		<b>93</b>				
<b>8140.67.2500</b>	05.1989 → 03.2001	D (NA)	4	2499 cm <sup>3</sup>	2V	55 kW (75 PS) 22 92,00 mm
<b>8140.67.2510</b>	08.1989 → 07.1998	D (NA)	4	2499 cm <sup>3</sup>	2V	55 kW (75 PS) 21 92,00 mm
<b>8140.67.2550</b>	05.1989 → 03.2001	D (NA)	4	2499 cm <sup>3</sup>	2V	55 kW (75 PS) 21 92,00 mm
<b>8140.67.2580 Euro 2</b>	05.1989 → 03.2001	D (NA)	4	2499 cm <sup>3</sup>	2V	55 kW (75 PS) 18,5 92,00 mm
	[50] Ø 8 mm [50] Ø 8 mm					50 01 001 245 <b>RK-8</b> <b>RK-8H</b>
	IN/EX [4] 13,07 x 8.02 x 60,0	G1			50 01 001 581	<b>81-17114</b> (1)
(1) ohne Ventilschaftabdichtung/without valve stem gasket/sans joint de tige de soupape/sin junta de vástago de válvula/без уплотнения стержня клапана						
						<b>50 007 054</b>
<b>103</b>		<b>93</b>				
<b>8140.47.2530 Euro 1</b>	10.1991 → 07.1996	D (LA)	4	2499 cm <sup>3</sup>	2V	85 kW (116 PS) 18,5:1 92,00 mm
	IN [2] 41,0 x 8 x 120,8	S - Cr -		- 30° -	- 9 - III	77 01 030 863 <b>171120</b> 77 01 462 678 77 01 463 603
	EX [2] 34,5 x 8 x 122,0	A/S - Cr -		- 45° -	- 9 - III	<b>17063</b>
	EX [2] 36,0 x 8 x 122,0	A/S - Cr -		- 45° -	- 9 - III	<b>171055</b>
	[50] Ø 8 mm [50] Ø 8 mm					50 01 001 245 <b>RK-8</b> <b>RK-8H</b>
	IN/EX [4] 13,02 x 8.02 x 56,0 IN/EX [4] 13,07 x 8.02 x 56,0 IN/EX [4] 13,07 x 8.02 x 60,0 IN/EX [4] 13,12 x 8 x 56,0	G1 G1 G1 G1			50 01 001 581	<b>81-17116</b> <b>81-17115</b> <b>81-17114</b> (1) <b>81-5611</b>
(1) ohne Ventilschaftabdichtung/without valve stem gasket/sans joint de tige de soupape/sin junta de vástago de válvula/без уплотнения стержня клапана						
						<b>50 007 054</b>
	[8] M 44 x 32					<b>50 006 180</b>
<b>104</b>		<b>93</b>				
<b>S8U</b>	<b>763</b>					
	12.1992 → 07.1996	D (LA)	4	2499 cm <sup>3</sup>	2V	83 kW (113 PS) 21 92,00 mm
	IN [2] 41,0 x 8 x 120,8	S - Cr -		- 30° -	- 9 - III	77 01 030 863 <b>171120</b> 77 01 462 678 77 01 463 603
	[50] Ø 8 mm [50] Ø 8 mm					50 01 001 245 <b>RK-8</b> <b>RK-8H</b>
	IN/EX [4] 13,02 x 8.02 x 56,0 IN/EX [4] 13,07 x 8.02 x 56,0 IN/EX [4] 13,07 x 8.02 x 60,0 IN/EX [4] 13,12 x 8 x 56,0	G1 G1 G1 G1			50 01 001 581	<b>81-17116</b> <b>81-17115</b> <b>81-17114</b> (1) <b>81-5611</b>
(1) ohne Ventilschaftabdichtung/without valve stem gasket/sans joint de tige de soupape/sin junta de vástago de válvula/без уплотнения стержня клапана						

					Reference	Item No.	
<b>105</b>		<b>93</b>					
<b>8140.27.2590</b>	01.1994 → 09.1997	D (A)	4	2499 cm <sup>3</sup>	2V	69 kW (94 PS) 18,5:1 92,00 mm	
	IN [2]	41,0 x 8 x 120,8	S - Cr -	- 30° -	- 9 - III	77 01 030 863 77 01 462 678 77 01 463 603	<b>171120</b>
	EX [2]	36,0 x 8 x 122,0	A/S - Cr -	- 45° -	- 9 - III		<b>171055</b>
	[50]	∅ 8 mm				50 01 001 245	<b>RK-8</b> <b>RK-8H</b>
	[50]	∅ 8 mm					
	IN/EX [4]	13,02 x 8.02 x 56,0	G1			50 01 001 581	<b>81-17116</b>
	IN/EX [4]	13,07 x 8.02 x 56,0	G1				<b>81-17115</b>
	IN/EX [4]	13,07 x 8.02 x 60,0	G1				<b>81-17114</b> (1)
	IN/EX [4]	13,12 x 8 x 56,0	G1				<b>81-5611</b>
	(1) ohne Ventilschaftabdichtung/without valve stem gasket/sans joint de tige de soupape/sin junta de vástago de válvula/без уплотнения стержня клапана						
	[8]	M 44 x 32					<b>50 006 180</b>
<b>106</b>		<b>94,4</b>					
<b>8140.27.2565 Euro 1</b>	08.1990 → 08.1996	D (A)	4	2798 cm <sup>3</sup>	2V	78 kW (106 PS) 18,5:1 100,00 mm	
	IN [2]	41,0 x 8 x 120,8	S - Cr -	- 30° -	- 9 - III	77 01 030 863 77 01 462 678 77 01 463 603	<b>171120</b>
	IN [2]	41,0 x 8 x 121,9	A/S - Ni -	- 30° -	- 1 - III		<b>17080</b>
	EX [2]	36,0 x 8 x 122,0	A/S - Cr -	- 45° -	- 9 - III		<b>171055</b>
	[50]	∅ 8 mm				50 01 001 245	<b>RK-8</b> <b>RK-8H</b>
	[50]	∅ 8 mm					
	IN/EX [4]	13,02 x 8.02 x 56,0	G1			50 01 001 581	<b>81-17116</b>
	IN/EX [4]	13,07 x 8.02 x 56,0	G1				<b>81-17115</b>
	IN/EX [4]	13,07 x 8.02 x 60,0	G1				<b>81-17114</b> (1)
	IN/EX [4]	13,12 x 8 x 56,0	G1				<b>81-5611</b>
	(1) ohne Ventilschaftabdichtung/without valve stem gasket/sans joint de tige de soupape/sin junta de vástago de válvula/без уплотнения стержня клапана						
	[8]	M 44 x 32					<b>50 006 180</b>
<b>107</b>		<b>94,4</b>					
<b>S9W Euro 2</b>	<b>702</b>	07.1998 → 09.2004	D (A)	4	2799 cm <sup>3</sup>	2V	84 kW (114 PS) 19 100,00 mm
94 701 6..							
	IN [2]	41,0 x 8 x 120,8	S - Cr -	- 30° -	- 9 - III	77 01 030 863 77 01 462 678 77 01 463 603	<b>171120</b>
	[50]	∅ 8 mm				50 01 001 245	<b>RK-8</b> <b>RK-8H</b>
	[50]	∅ 8 mm					
	IN/EX [4]	13,02 x 8.02 x 56,0	G1			50 01 001 581	<b>81-17116</b>
	IN/EX [4]	13,07 x 8.02 x 56,0	G1				<b>81-17115</b>
	IN/EX [4]	13,07 x 8.02 x 60,0	G1				<b>81-17114</b> (1)
	IN/EX [4]	13,12 x 8 x 56,0	G1				<b>81-5611</b>
	(1) ohne Ventilschaftabdichtung/without valve stem gasket/sans joint de tige de soupape/sin junta de vástago de válvula/без уплотнения стержня клапана						

					Reference	Item No.	
<b>108</b>		<b>95</b>					
<b>D 225-2</b>	01.1969 → 1981	D (NA) 2	1700 cm <sup>3</sup> 2V	13-24 kW	(18-33 PS) 18:1	120,00 mm	
<b>D 325-2</b>	01.1969 → 1981	D (NA) 2	1700 cm <sup>3</sup> 2V	21-25 kW	(29-34 PS) 18:1	120,00 mm	
<b>D 325-3</b>	01.1969 → 1981	D (NA) 3	2551 cm <sup>3</sup> 2V	25-35 kW	(34-48 PS) 18:1	120,00 mm	
<b>D 325-4</b>	01.1969 → 1981	D (NA) 4	3400 cm <sup>3</sup> 2V	43-51 kW	(58-69 PS) 18:1	120,00 mm	
91 005 7..							
	IN [2] EX [2]	38,0 x 9 x 117,0 35,0 x 9 x 117,0	S - Cr - A/S - Cr -	- 45° - - - 45° - -	22 - III 22 - III	<b>2723</b> <b>2721</b>	
	[50]	∅ 9 mm				<b>MK-9H</b>	
	IN/EX [4]	15,00/16.5 x 9 x 58,0	G2			<b>81-2722</b>	
<b>109</b>		<b>95</b>					
<b>D 225-3</b>	01.1969 → 1981	D (NA) 3	2550 cm <sup>3</sup> 2V	35-37 kW	(48-50 PS) 18:1	120,00 mm	
91 005 7..							
	IN [2] EX [2]	38,0 x 9 x 117,0 35,0 x 9 x 117,0	S - Cr - A/S - Cr -	- 45° - - - 45° - -	22 - III 22 - III	<b>2723</b> <b>2721</b>	
	[50]	∅ 9 mm				<b>MK-9H</b>	
	IN/EX [4]	15,00/16.5 x 9 x 58,0	G2			<b>81-2722</b>	
	[12]	M 27 x 50,3 x 18				<b>20 1005 22510</b>	
<b>110</b>		<b>98</b>					
<b>AKD</b>	<b>112-3</b>	01.1960 → 1965	D (NA) 3	2715 cm <sup>3</sup> 2V	24 kW	(33 PS) 19,5:1 120,00 mm	
<b>AKD</b>	<b>112-2</b>	01.1960 → 1965	D (NA) 2	1810 cm <sup>3</sup> 2V	14-18 kW	(20-24 PS) 19,5:1 120,00 mm	
	IN [2] EX [2]	41,0 x 10 x 129,0 37,0 x 10 x 129,0	S - Cr - S - Cr -	- 45° - - - 45° - -	8 - III 8 - III	<b>2786</b> <b>2787</b>	
	IN/EX [4]	15,00/18 x 10 x 66,0	G2			<b>81-2706</b>	
<b>111</b>		<b>98</b>					
<b>712</b>		D (NA) 4	3320 cm <sup>3</sup> 2V	56 kW	(76 PS) 17,5:1	110,00 mm	
	IN [2] EX [2]	45,8 x 10 x 140,2 38,9 x 10 x 140,3	A/S - Cr - A/S - Cr -	- 30° - - - 45° - -	1 - III 1 - III	<b>597673</b> <b>425351</b>	
	[50]	∅ 10 mm				<b>KK-10H</b>	
	IN [4] EX [4]	16,07 x 9.96 x 86,0 16,07 x 9.96 x 67,0	G1 G1			<b>81-59000</b> <b>81-59001</b>	
<b>112</b>		<b>98,48</b>					
<b>A 4.236</b>		D	4	3864 cm <sup>3</sup> 2V	37-65 kW	(50-89 PS) 16:1 126,80 mm	
91 118 6..							
Fortsetzung nächste Seite / continued on next page / suite page suivante / continuación página próxima / Продолжение на следующей странице							

					Reference	Item No.
	IN [2] 44,2 x 9,5 x 122,8 IN [2] 44,2 x 9,5 x 122,8 M + 1	S - - S - -	- 45° - - - 45° - -	1 - III 1 - III		<b>105-03365</b> <b>105-35472</b>
	EX [2] 36,5 x 9,5 x 123,2 EX [2] 36,6 x 9,5 x 123,3 M + 1	A/S - - A/S - -	- 45° - - - 45° - -	1 - III 1 - III		<b>105-03366</b> <b>105-35473</b>
	IN [6] 15,90 x 9.515 x 57,9 EX [6] 15,90 x 9.53 x 61,1	G2 G2				<b>81-85003</b> <b>81-85004</b>

## 113 100

<b>D 227-4</b>	01.1970 → 1977	D (NA)	4	3768 cm <sup>3</sup>	2V	46-61 kW	(63-83 PS)	18:1	120,00 mm
<b>D 227-6</b>	01.1970 →	D (NA)	6	5654 cm <sup>3</sup>	2V	63-91 kW	(86-124 PS)	18:1	120,00 mm
<b>D 327-2</b>	01.1972 → 1977	D (NA)	2	1885 cm <sup>3</sup>	2V	24-27 kW	(33-37 PS)	18:1	120,00 mm
<b>D 327-3</b>	01.1970 →	D (NA)	3	2827 cm <sup>3</sup>	2V	26-48 kW	(35-65 PS)	18:1	120,00 mm
<b>D 327-4</b>	01.1970 →	D (NA)	4	3768 cm <sup>3</sup>	2V	45-55 kW	(61-75 PS)	18:1	120,00 mm

91 753 6..., 93 063 6..

	IN [2] 41,0 x 9 x 117,0 EX [2] 38,0 x 9 x 117,0	S - Cr - A/S - Cr -	- 45° - - - 45° - -	22 - III 22 - III		<b>2726</b> <b>2757</b>
	[50]	Ø 9 mm				<b>MK-9H</b>
	IN/EX [4] 15,00/16.5 x 9 x 58,0	G2				<b>81-2722</b>
	[12]	M 28 x 56,8 x 18				<b>20 0105 22700</b>

## 114 102

<b>797-20</b>	06.1980 → 05.1991	D (A)	6	5491 cm <sup>3</sup>	2V	95-98 kW	(129-133 PS)	17,5:1	112,00 mm
<b>798</b>		D (A)	6	5489 cm <sup>3</sup>	2V	110-113 kW	(150-154 PS)	17:1	112,10 mm
<b>798-20</b>	09.1984 → 01.1995	D (A)	6	5490 cm <sup>3</sup>	2V	113 kW	(154 PS)	17:1	112,00 mm
<b>MIDR 06.02.12</b>		D (LA)	6	5491 cm <sup>3</sup>	2V	128-134 kW	(173-182 PS)	17:1	112,00 mm
<b>MIDS 06.02.12</b>		D (A)	6	5491 cm <sup>3</sup>	2V	107 kW	(145 PS)		112,00 mm
<b>MIDS 06.02.12 B</b>	10.1991 → 01.1995	D (A)	6	5491 cm <sup>3</sup>	2V	113-117 kW	(154-159 PS)	17:1	112,00 mm
<b>MIDS 06.02.12 D</b>		D (A)	6	5491 cm <sup>3</sup>	2V	110 kW	(150 PS)	17:1	112,00 mm

	IN [2] 45,8 x 10 x 140,2 EX [2] 38,9 x 10 x 140,3	A/S - Cr - A/S - Cr -	- 30° - - - 45° - -	1 - III 1 - III		<b>59763</b> <b>425351</b>
	[50]	Ø 10 mm				<b>KK-10H</b>
	IN [4] 16,07 x 9.96 x 86,0 EX [4] 16,07 x 9.96 x 67,0	G1 G1				<b>81-59000</b> <b>81-59001</b>

## 115 102

<b>MIDR 06.02.26 DU</b>		D (LA)	6	6177 cm <sup>3</sup>	2V	166 kW	(226 PS)		126,00 mm
-------------------------	--	--------	---	----------------------	----	--------	----------	--	-----------

94 724 7..

	IN [2] 46,5 x 10 x 140,2 EX [2] 40,5 x 10 x 140,2	A/S - Cr - A/S - Cr -	- 30° - - - 45° - -	1 - III 1 - III		<b>59108</b> <b>59109</b>
	[50]	Ø 10 mm				<b>KK-10H</b>

## 116 102

<b>MIDR 06.02.26 I</b>		D (LA)	6	6177 cm <sup>3</sup>	2V	133 kW	(181 PS)		126,00 mm
<b>MIDR 06.02.26 K</b>		D (LA)	6	6177 cm <sup>3</sup>	2V	155 kW	(211 PS)		126,00 mm
<b>MIDR 06.02.26 L</b>		D (LA)	6	6177 cm <sup>3</sup>	2V	132 kW	(180 PS)		126,00 mm
<b>MIDR 06.02.26 L2</b>		D (LA)	6	6177 cm <sup>3</sup>	2V	132 kW	(180 PS)		126,00 mm
<b>MIDR 06.02.26 M</b>		D (LA)	6	6177 cm <sup>3</sup>	2V	155 kW	(211 PS)		126,00 mm
<b>MIDR 06.02.26 M2</b>		D (LA)	6	6177 cm <sup>3</sup>	2V	155 kW	(211 PS)		126,00 mm

Fortsetzung nächste Seite / continued on next page / suite page suivante / continuación página próxima / Продолжение на следующей странице

					Reference	Item No.
	IN [1] EX [1]	16,03 x 10 x 78,0 16,03 x 10 x 67,0	G2 G2			<b>81-59006</b> <small>NEW</small> <b>81-59007</b> <small>NEW</small>

## 117

<b>D 226-3</b>	01.1968 →	D (NA)	3	3120 cm <sup>3</sup>	2V	33-44 kW	(45-60 PS)	17,8:1	120,00 mm
<b>D 226-4</b>	01.1968 →	D (NA)	4	4160 cm <sup>3</sup>	2V	44-64 kW	(60-87 PS)	18:1	120,00 mm
<b>D 226-6</b>	01.1969 →	D (NA)	6	6234 cm <sup>3</sup>	2V	66-114 kW	(90-155 PS)	18:1	120,00 mm

91 557 7..., 93 061 6..., 93 069 6..

	IN [2] EX [2]	41,0 x 9 x 117,0 38,0 x 9 x 117,0	S - Cr - A/S - Cr -	- 45° - - 45° -	- -	22 - III 22 - III		<b>2726</b> <b>2757</b>
	[50]	∅ 9 mm						<b>MK-9H</b>
	IN/EX [4]	15,00/16.5 x 9 x 58,0	G2					<b>81-2722</b>
	[12] [1]	M 28 x 56,8 x 18 M					60 05 024 961	<b>20 0105 22700</b> <b>20 1005 22660</b> (1)
	(1)	3-rillig/groove/gorges/nervaduras/канавками						

## 118

<b>TD 226 B-6</b>	01.1969 →	D (A)	6	6234 cm <sup>3</sup>	2V	81-136 kW	(110-185 PS)	16,4:1	120,00 mm
-------------------	-----------	-------	---	----------------------	----	-----------	--------------	--------	-----------

90 093 6..

	IN [2] EX [2]	47,0 x 9 x 117,0 43,0 x 9 x 117,0	A/S - Cr - A/S - Cr -	- 30° - - 45° -	- -	22 - III 22 - III		<b>27119</b> <b>27104</b>
	[50]	∅ 9 mm						<b>MK-9H</b>
	IN [4] EX [4]	15,00 x 9 x 58,0 15,00 x 9 x 51,5	G2 CC G2 CC					<b>81-2728</b> <b>81-2729</b>
	IN [1] EX [1]	48,05 x 39 x 6,2 45,05 x 36 x 7,2	G1 30° G1 45°					<b>92-22021</b> <small>NEW</small> <b>92-22022</b> <small>NEW</small>
	[1]	M					60 05 024 961	<b>20 1005 22660</b> (1)
	(1)	3-rillig/groove/gorges/nervaduras/канавками						

## 119

<b>TD 226-4</b>	01.1969 →	D (A)	4	4160 cm <sup>3</sup>	2V	68-74 kW	(93-100 PS)	15,5:1	120,00 mm
-----------------	-----------	-------	---	----------------------	----	----------	-------------	--------	-----------

93 045 6..

	IN [2] EX [2]	42,0 x 9 x 117,2 38,0 x 9 x 117,0	S - Cr - A/S - Cr -	- 30° - - 45° -	- -	22 - III 22 - III		<b>2734</b> <b>2757</b>
	[50]	∅ 9 mm						<b>MK-9H</b>
	IN/EX [4]	15,00/16.5 x 9 x 58,0	G2					<b>81-2722</b>
	[12] [1]	M 28 x 56,8 x 18 M					60 05 024 961	<b>20 0105 22700</b> <b>20 1005 22660</b> (1)
	(1)	3-rillig/groove/gorges/nervaduras/канавками						

## 120

<b>TD 228-6</b>	01.1976 →	D (A)	6	6234 cm <sup>3</sup>	2V	99-110 kW	(135-150 PS)	16:1	120,00 mm
-----------------	-----------	-------	---	----------------------	----	-----------	--------------	------	-----------

Fortsetzung nächste Seite / continued on next page / suite page suivante / continuación página próxima / Продолжение на следующей странице



					Reference	Item No.
IN [2] EX [2]	42,0 x 9 x 117,2 38,0 x 9 x 117,0	S - Cr - A/S - Cr -	- 30° - - 45° -	- -	22 - III 22 - III	<b>2734</b> <b>2757</b>
[50]	Ø 9 mm					<b>MK-9H</b>
IN/EX [4]	15,00/16.5 x 9 x 58,0	G2				<b>81-2722</b>

## 121 120

MID	06.20.30 G	D (NA)	6	8822 cm <sup>3</sup>	2V	141 kW	(192 PS)	17:1	130,00 mm
<b>MIDR 06.20.30</b>		(LA)	6	8822 cm <sup>3</sup>	2V	194 kW	(264 PS)	15:1	130,00 mm
<b>MIDR 06.20.45 BC</b>		(LA)	6	9839 cm <sup>3</sup>	2V	195 kW	(265 PS)		145,00 mm
<b>MIDR 06.20.45 C</b>		(LA)	6	9839 cm <sup>3</sup>	2V	206-210 kW	(280-285 PS)	16:1	145,00 mm
<b>MIDR 06.20.45 DD</b>		(LA)	6	9839 cm <sup>3</sup>	2V	222 kW	(302 PS)	18:1	145,00 mm
<b>MIDS 06.20.45 D</b>		(A)	6	9839 cm <sup>3</sup>	2V	129 kW	(175 PS)	17:1	145,00 mm
MIP	06.20.30	D (NA)	6	8820 cm <sup>3</sup>	2V	141-158 kW	(192-215 PS)	17:1	130,00 mm
<b>MIPR 06.20.45</b>		(LA)	6	9840 cm <sup>3</sup>	2V	195-265 kW	(265-360 PS)	17:1	145,00 mm
<b>MIPS 06.20.30</b>		(A)	6	8820 cm <sup>3</sup>	2V	166 kW	(225 PS)		130,00 mm
<b>MIPS 06.20.45</b>		(LA)	6	9840 cm <sup>3</sup>	2V	137-186 kW	(186-253 PS)	17:1	145,00 mm

90 747 7..., 91 681 7..., 91 683 7..., 99 844 6..., 99 943 6..

IN [2] EX [2]	54,0 x 9 x 163,3 48,0 x 9 x 163,1	A/S - Cr - A/S - Cr -	- 30° - - 45° -	- -	1 - III 1 - III	<b>598142</b> <b>598141</b>
IN/EX [6] IN [6] EX [6]	17,05 x 9.06 x 78,0 17,04 x 9.06 x 78,0 17,53 x 9.06 x 78,0	G1 G1 G1				<b>81-59002</b> <b>81-59003</b> <b>81-59005</b>

## 122 123

DXi Euro 3	11 330, 11 440	D (A)	6	10837 cm <sup>3</sup>	4V	243-324 kW	(330-441 PS)	18:1	152,00 mm
IN [2] EX [2]	40,0 x 8 x 192,0 38,0 x 8 x 192,7	RA/S- Cr - RA/S- Cr -	- 30° - - 30° -	VS - VS -	22 - III 22 - III	<b>48313</b> <b>48314</b>			
[50]	Ø 8 mm					<b>MK-8H</b>			
IN/EX [6]	15,00 x 8.01 x 83,4	G2				<b>81-47119</b>			
IN/EX [6]	15,00 x 8.02 x 83,2	G2				<b>81-47114</b>			
IN [1] IN [1] EX [1] EX [1]	42,00 x 33 x 7,3 42,04 x 33 x 7,4 40,00 x 31.2 x 6,4 40,04 x 31.2 x 6,4	G3 30° G1 30° G3 30° G1 30°				<b>92-47030</b> <b>92-59000</b> <b>92-47031</b> <b>92-59001</b>			
(1)	(1) EBR-EPG Motorbremsentyp - Auspuffdrucklager/engine brake type - exhaust thrust bearing/type de frein moteur - butée d'embrayage/tipo de freno del motor: cojinete de empuje de gases de escape/Тип моторного тормоза — упорный подшипник системы выпуска					74 20 746 807 74 22 584 593	<b>20 1004 11001</b> (1)		

					Reference	Item No.
<b>123</b>	<b>123</b>	<b>DXi Euro 4/5 11 370, 11 450</b>				
		D (A)	6	10837 cm <sup>3</sup> 4V	272-332 kW (370-451 PS) 18:1	152,00 mm
	IN [2] EX [2]	40,0 x 8 x 192,0 38,0 x 8 x 192,7	RA/S- Cr - RA/S- Cr -	- 30° - VS - - 30° - VS -	22 - III 22 - III	<b>48313</b> <b>48314</b>
	[50]	∅ 8 mm				<b>MK-8H</b>
	IN/EX [6]	15,00 x 8.01 x 83,4	G2		00 20 905 400 74 03 165 303 74 20 904 074	<b>81-47119</b>
	IN/EX [6]	15,00 x 8.02 x 83,2	G2		00 20 905 400 74 03 165 303 74 20 904 074 74 20 905 400	<b>81-47114</b>
	IN [1] IN [1] EX [1] EX [1]	42,00 x 33 x 7,3 42,04 x 33 x 7,4 40,00 x 31.2 x 6,4 40,04 x 31.2 x 6,4	G3 30° G1 30° G3 30° G1 30°			<b>92-47030</b> <small>NEW</small> <b>92-59000</b> <b>92-47031</b> <small>NEW</small> <b>92-59001</b>
					74 20 746 807 74 22 584 593 74 21 189 194 74 22 584 592	<b>20 1004 11001</b> (1) <b>20 1004 11002</b> (2)
	(1) EBR-EPG Motorbremsentyp - Auspuffdrucklager/engine brake type - exhaust thrust bearing/type de frein moteur - butée d'embrayage/tipo de freno del motor: cojinete de empuje de gases de escape/ Тип моторного тормоза — упорный подшипник системы выпуска					
	(2) Volvo information: EBR-VEB/EBR-EPGC,EM-EC06/EM-EU5					
<b>124</b>	<b>123</b>	<b>MIDR 06.23.56 B/43 Euro 3</b>				
		D (LA)	6	11122 cm <sup>3</sup> 2V	303 kW (412 PS) 17:1	156,00 mm
	IN [2] EX [2]	54,0 x 9 x 163,3 48,0 x 9 x 163,1	A/S - Cr - A/S - Cr -	- 30° - - - 45° - -	1 - III 1 - III	<b>598142</b> <b>598141</b>
	IN/EX [6] IN [6] EX [6]	17,05 x 9.06 x 78,0 17,04 x 9.06 x 78,0 17,53 x 9.06 x 78,0	G1 G1 G1			<b>81-59002</b> <b>81-59003</b> <b>81-59005</b>
<b>125</b>	<b>124</b>	<b>MIDR 06.24.65 AB Euro 2</b>				
		D (LA)	6	11955 cm <sup>3</sup> 4V	287 kW (390 PS)	165,00 mm
	IN/EX [4]	20,04 x 12.03 x 105,0	G1		50 10 248 411	<b>81-59004</b>
<b>126</b>	<b>131</b>	<b>DXi Euro 4/5 13 440, 13 480, 13 520</b>				
		D (LA)	6	12777 cm <sup>3</sup> 4V	323-382 kW (440-520 PS) 18:1	158,00 mm
40 834 6..						
	IN [2] EX [2]	42,0 x 8 x 192,0 40,0 x 8 x 191,7	RA/S- Cr - NB/S- Cr -	- 24.5°- VS - - 39.5°- VS -	22 - III 22 - III	<b>48315</b> <b>48316</b>
	[50]	∅ 8 mm				<b>MK-8H</b>
Fortsetzung nächste Seite / continued on next page / suite page suivante / continuación página próxima / Продолжение на следующей странице						

					Reference	Item No.
	IN/EX [6] 15,00 x 8.01 x 83,4	G2			00 20 905 400 74 03 165 303 74 20 904 074	<b>81-47119</b>
	IN/EX [6] 15,00 x 8.02 x 83,2	G2			00 20 905 400 74 03 165 303 74 20 904 074 74 20 905 400	<b>81-47114</b>
	IN [1] 45,05 x 34 x 7,5	G1 24.5°				<b>92-47028</b> <small>NEW</small>
	IN [1] 45,10 x 34 x 7,5	G1 24°				<b>92-47034</b>
	EX [1] 43,05 x 33 x 7,5	G1 39.5°				<b>92-47029</b> <small>NEW</small>
	EX [1] 43,10 x 33 x 7,5	G1 30°				<b>92-47035</b>
					74 21 110 842	<b>20 1004 13001</b> (1)

(1) Motorbremsentyp/engine brake type/type de freine de moteur/Тип моторного тормоза

<b>127</b>		<b>131</b>
<b>DXi Euro 4/5</b>		<b>13 460, 13 500</b>
40 834 6..	D (LA) 6	12777 cm <sup>3</sup> 4V 338-368 kW (460-500 PS) 18:1 158,00 mm

	IN [2] 42,0 x 8 x 192,0	RA/S- Cr -	- 24.5°- VS -	22 - III		<b>48315</b>
	EX [2] 40,0 x 8 x 191,7	NB/S- Cr -	- 39.5°- VS -	22 - III		<b>48316</b>
	[50] Ø 8 mm					<b>MK-8H</b>
	IN/EX [6] 15,00 x 8.01 x 83,4	G2			00 20 905 400 74 03 165 303 74 20 904 074	<b>81-47119</b>
	IN/EX [6] 15,00 x 8.02 x 83,2	G2			00 20 905 400 74 03 165 303 74 20 904 074 74 20 905 400	<b>81-47114</b>
	IN [1] 45,05 x 34 x 7,5	G1 24.5°				<b>92-47028</b> <small>NEW</small>
	IN [1] 45,10 x 34 x 7,5	G1 24°				<b>92-47034</b>
	EX [1] 43,05 x 33 x 7,5	G1 39.5°				<b>92-47029</b> <small>NEW</small>
	EX [1] 43,10 x 33 x 7,5	G1 30°				<b>92-47035</b>
					74 21 110 842 74 21 110 437	<b>20 1004 13001</b> (1) <b>20 1004 13005</b> (2)







(1) Motorbremsentyp/engine brake type/type de freine de moteur/Тип моторного тормоза

(2) EBR-VEB (Motorbremsentyp - Volvo Motorbremse einschließlich Auspuffdrucklager)  
 EBR-EPGC (Motorbremsentyp - Auspuffdruckregler mit VCB (Volvo Kompressionsbremse))  
 EBR-VEB - (engine brake type - Volvo engine brake including exhaust thrust bearing)  
 EPGC - (engine brake type - integrated pressure regulator with VCB (Volvo compression brake))  
 EBR-VEB - (type de frein moteur - frein moteur Volvo avec butée d'embrayage)  
 EPGC - (type de frein moteur - butée d'embrayage avec VCB (frein par compression Volvo))  
 EBR-VEB - (tipo de freno del motor: freno del motor Volvo incluido cojinete de empuje de gases de escape)  
 EPGC - (tipo de freno del motor: regulador de empuje de gases de escape con VCB (freno de compresión Volvo))  
 EBR-VEB (Тип моторного тормоза — моторный тормоз Volvo вместе с упорным подшипником системы выпуска)  
 EPGC - (Тип моторного тормоза — регулятор давления системы выпуска с VCB (компрессионный тормоз Volvo))

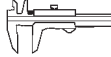
<b>128</b>		<b>135</b>
<b>MIDS 06.35.40 B</b>		<b>MIDS 06.35.40 E</b>
93 987 7..	D (A) 6	12024 cm <sup>3</sup> 2V 225 kW (306 PS) 140,00 mm
	D (A) 6	12024 cm <sup>3</sup> 2V 195 kW (265 PS) 15:1 140,00 mm

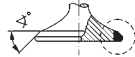
	IN [1] 60,0 x 12 x 189,3	A/S - Cr -	- 30° - -	1 - III		<b>598349</b>
	EX [1] 54,0 x 12 x 189,3	A - Cr -	- 45° - -	1 - III		<b>595915</b>

Fortsetzung nächste Seite / continued on next page / suite page suivante / continuación página próxima / Продолжение на следующей странице

					Reference	Item No.
 [50]	Ø 12 mm					KK-12H
 IN/EX [4]	20,04 x 12.03 x 105,0	G1			50 10 248 411	81-59004

R

	Cyl.	mm	cm <sup>3</sup>	Comp. Ratio $\epsilon$	kW	PS	Pos
14 K2A	B (NA) 4	75 x 79	1396	2 9,5:1	55	75	5
14 K4C	B (NA) 4	75 x 79	1396	4 9,5	66-70	90-95	3
14 K4F	B (NA) 4	75 x 79	1396	4 9,5	76	103	5
14K2	B (NA) 4	75 x 79	1396	2 10,5	62-63	84-86	3
16 H	B (NA) 4	76,2 x 87,6	1598	2 9,6	61-75	83-102	8
18 K4F	B (NA) 4	80 x 89,3	1796	4 10,5	85-88	116-120	10
18 K4K	B (NA) 4	80 x 89,3	1796	4 10,5	107-110	146-150	10
20 H	B (NA) 4	84,5 x 89	1994	2 9,1:1	75-86	102-117	16
A Plus	B 4	64,56 x 76,2	998	2 8,3:1	29-35	39-48	1
D 16 A7	B (NA) 4	75 x 90	1590	4 9,5	85	116	2
D 16 A8	B (NA) 4	75 x 90	1590	4 9,5:1	90	122	4
D 16 A9	B (NA) 4	75 x 90	1590	4 9,5	96	131	6
D 16 Z2	B (NA) 4	75 x 90	1590	4 9,1:1	82	112	4
F 18 A3	B (NA) 4	85 x 81,5	1850	4 9	85	115	17
F 20 Z1	B (NA) 4	85 x 88	1997	4 9	96	131	17
F 20 Z2	B (NA) 4	85 x 88	1997	4 9:1	85	115	17
F20A	B (NA) 4	85 x 88	1997	4 9	85-96	116-131	17
K 16	B 4	75 x 79	1396	4 9,5:1	76	103	3
K 16-1.6	B 4	80 x 79	1588	4 10,5:1	82	111	10
M 47 R	D (LA) 4	84 x 88	1950	4 19,5	85	116	12
M47 D20R	D (A) 4	84 x 88	1951	4 19,5:1	85	116	13
O Series (110 kW)	B (A) 4	84,45 x 88,9	1994	2 9:1	110	150	14
Prima 80 T	D (A) 4	84,45 x 88,9	1994	2 16,5:1	60	82	15
TUD 3	D (NA) 4	75 x 77	1361	2 22,1	38	52	7
TUD 5	D (NA) 4	77 x 82	1527	2 23	42	57	9
XUD 7TE	D (A) 4	80 x 88	1769	2 22	64-65	87-88	11

		Pos			Pos
			620 Si	08.1993 → 02.1999	F 20 Z1 B 17
			620 i	08.1993 → 06.1996	F 20 Z2 B 17
<b>100 / METRO Hatchback (XP)</b>			<b>75 I Tourer (RJ)</b>		
114 D	10.1992 → 12.1994	TUD 3 D 7	2.0 CDT	08.2001 → 05.2005	M 47 R D 12
114 GSi	10.1994 → 10.1995	14 K4F B 5	<b>AUSTIN MONTEGO</b>		
114 GTI 16V	03.1990 → 08.1991	14 K4C B 3	2.0 TD	09.1988 → 12.1993	Prima 80 T D 15
114 GTI 16V	08.1991 → 12.1998	14 K4F B 5	<b>CITYROVER Hatchback</b>		
114 GTI/GT 16V Cat	03.1990 → 12.1998	14 K4C B 3	1.4 Elegance	09.2003 → 12.2005	14K2 B 3
114 S/L/GTA	03.1990 → 12.1998	14 K2A B 5	<b>COUPE</b>		
115 D	12.1994 → 12.1998	TUD 5 D 9	1.8 16 V	03.1996 → 11.1999	18 K4K B 10
<b>100 Convertible (XP)</b>			<b>MAESTRO</b>		
114	04.1994 → 10.1997	14 K2A B 5	1.6i	09.1988 → 12.1993	16 H B 8
114	03.1997 → 10.1998	14 K4F B 5	2.0i	10.1984 → 12.1993	20 H B 16
<b>200 Coupe (XW)</b>			<b>MAESTRO Hatchback</b>		
216	10.1992 → 06.1999	D 16 A8 B 4	1.6	09.1990 → 01.1995	16 H B 8
<b>200 I Saloon (XH)</b>			<b>MINI</b>		
216	03.1985 → 09.1989	16 H B 8	1.4i 16V	09.1995 → 09.2000	K 16 B 3
216 Vitesse	09.1984 → 09.1989	16 H B 8	1000 MK II	10.1967 → 06.1993	A Plus B 1
<b>200 II Convertible (XW)</b>			<b>MONTEGO</b>		
214 1.4	04.1990 → 09.1992	14 K4C B 3	2.0 GTi	02.1985 → 10.1991	20 H B 16
214 1.4	01.1992 → 11.1999	14 K4C B 3	2.0 i Cat	12.1990 → 10.1994	20 H B 16
214 1.4i 16V	01.1993 → 11.1999	14 K4F B 5	<b>MONTEGO Estate (XE)</b>		
216 1.6	04.1990 → 02.1996	D 16 Z2 B 4	2.0 GTi/LXI	12.1990 → 12.1993	20 H B 16
216 1.6i	01.1992 → 11.1999	D 16 A8 B 4	2.0 GTi	10.1988 → 10.1991	20 H B 16
<b>200 II Hatchback (RF)</b>			<b>ROVER 400</b>		
214 Si	11.1995 → 03.2000	14 K4F B 5	416 SLi 16V	05.1995 → 03.2000	K 16-1.6 B 10
218 K Vi	11.1995 → 03.2000	18 K4K B 10	<b>ROVER 600</b>		
218 Si	08.1999 → 03.2000	18 K4F B 10	620i	09.1993 → 06.1996	F20A B 17
218 Td	03.1998 → 11.2000	XUD 7TE D 11	<b>STREETWISE Hatchback</b>		
<b>200 II Hatchback (XW)</b>			1.4	08.2003 → 05.2005	14 K4F B 5
214	09.1993 → 12.1995	14 K2A B 5	1.8	08.2003 → 05.2005	18 K4F B 10
214 GSi/Si	01.1990 → 10.1995	14 K4C B 3			
214 GSi/Si	12.1992 → 10.1995	14 K4F B 5			
214 Si/Gsi	10.1989 → 10.1995	14 K4C B 3			
216 GSi	10.1989 → 10.1995	D 16 A7 B 2			
216 GSi	01.1990 → 12.1995	D 16 Z2 B 4			
216 GTi	01.1990 → 10.1995	D 16 A8 B 4			
216 GTi	09.1990 → 10.1995	D 16 A9 B 6			
218 TD	09.1991 → 10.1995	XUD 7TE D 11			
<b>25 I Hatchback (RF)</b>					
1.4 16V	10.1999 → 05.2005	14 K4F B 5			
1.8 16V	10.1999 → 05.2005	18 K4F B 10			
1.8 16V	02.2000 → 05.2005	18 K4K B 10			
<b>400 II (RT)</b>					
414 Si	05.1995 → 03.2000	14 K4F B 5			
<b>400 II (XW)</b>					
414	01.1993 → 04.1995	14 K4C B 3			
414 GSi/Si	04.1990 → 04.1995	14 K4C B 3			
414 GSi/Si Cat	10.1992 → 04.1995	14 K4F B 5			
416 GSi	04.1990 → 04.1995	D 16 Z2 B 4			
416 GSi/GSE	04.1990 → 04.1995	D 16 A7 B 2			
416 GTI	04.1990 → 04.1995	D 16 A8 B 4			
416 GTI/GTE	04.1990 → 04.1995	D 16 A9 B 6			
418 TD	09.1991 → 04.1995	XUD 7TE D 11			
<b>400 II Hatchback (RT)</b>					
414 Si	05.1995 → 03.2000	14 K4F B 5			
<b>400 Tourer (XW)</b>					
1.6 i	05.1994 → 11.1998	D 16 A8 B 4			
1.6 i	05.1994 → 11.1998	D 16 Z2 B 4			
1.8 TD	09.1993 → 11.1998	XUD 7TE D 11			
1.8 i	06.1996 → 11.1998	18 K4K B 10			
<b>45 I Hatchback (RT)</b>					
1.4	02.2000 → 05.2005	14 K4F B 5			
1.8	02.2000 → 05.2005	18 K4F B 10			
<b>45 I Saloon (RT)</b>					
1.4	02.2000 → 05.2005	14 K4F B 5			
1.8	02.2000 → 05.2005	18 K4F B 10			
<b>600 I (RH)</b>					
618 i/Si	03.1996 → 02.1999	F 18 A3 B 17			

R



					Reference	Item No.
<b>1</b>		<b>64,56</b>				
<b>A Plus</b>		10.1967 → 06.1993	B	4	998 cm <sup>3</sup> 2V	29-35 kW (39-48 PS) 8,3:1 76,20 mm
	IN/EX [4]	11,94 x 7.1 x 42,9	G1			12G1111 <b>81-88004</b>
<b>2</b>		<b>75</b>				
<b>D 16 A7</b>		10.1989 → 10.1995	B (NA)	4	1590 cm <sup>3</sup> 4V	85 kW (116 PS) 9,5 90,00 mm
	IN [2]	29,0 x 5,5 x 115,0	S - Ni -	- 45° - VS -	1 - III	<b>V3816</b>
<b>3</b>		<b>75</b>				
<b>14 K4C</b>		10.1989 → 11.1999	B (NA)	4	1396 cm <sup>3</sup> 4V	66-70 kW (90-95 PS) 9,5 79,00 mm
<b>14K2</b>		09.2003 → 12.2005	B (NA)	4	1396 cm <sup>3</sup> 2V	62-63 kW (84-86 PS) 10,5 79,00 mm
<b>K 16</b>		09.1995 → 09.2000	B	4	1396 cm <sup>3</sup> 4V	76 kW (103 PS) 9,5:1 79,00 mm
	IN/EX [4]	9,88 x 6.01 x 30,0	G1			WAM 1452 <b>81-88000</b>
<b>4</b>		<b>75</b>				
<b>D 16 A8</b>		01.1990 → 11.1999	B (NA)	4	1590 cm <sup>3</sup> 4V	90 kW (122 PS) 9,5:1 90,00 mm
<b>D 16 Z2</b>		01.1990 → 11.1998	B (NA)	4	1590 cm <sup>3</sup> 4V	82 kW (112 PS) 9,1:1 90,00 mm
	IN [2]	29,0 x 5,5 x 115,0	S - Ni -	- 45° - VS -	1 - III	<b>V3816</b>
	IN [4]	12,11 x 6.6 x 45,0	G2			<b>81-72003</b>
	EX [4]	11,06 x 5.5 x 54,0	G1			<b>81-72001</b>
	EX [4]	12,10 x 6.6 x 50,0	G2			<b>81-72000</b>
<b>5</b>		<b>75</b>				
<b>14 K2A</b>		03.1990 → 12.1998	B (NA)	4	1396 cm <sup>3</sup> 2V	55 kW (75 PS) 9,5:1 79,00 mm
<b>14 K4F</b>		08.1991 → 05.2005	B (NA)	4	1396 cm <sup>3</sup> 4V	76 kW (103 PS) 9,5 79,00 mm
	IN [2]	27,7 x 6 x 89,6	S - Ni -	- 45° - -	1 -	LGH10029 <b>105-35474</b>
	EX [2]	24,1 x 6 x 90,0	A - Ni -	- 45° - VS -	1 -	LGH100820 <b>105-35475</b>
						LGH101190
	IN/EX [4]	9,88 x 6.01 x 30,0	G1			WAM 1452 <b>81-88000</b>
<b>6</b>		<b>75</b>				
<b>D 16 A9</b>		04.1990 → 10.1995	B (NA)	4	1590 cm <sup>3</sup> 4V	96 kW (131 PS) 9,5 90,00 mm
	IN [4]	12,11 x 6.6 x 45,0	G2			<b>81-72003</b>
	EX [4]	12,10 x 6.6 x 50,0	G2			<b>81-72000</b>
<b>7</b>		<b>75</b>				
<b>TUD 3</b>		10.1992 → 12.1994	D (NA)	4	1361 cm <sup>3</sup> 2V	38 kW (52 PS) 22,1 77,00 mm
	[50]	∅ 7 mm				<b>KK-7H</b>
<b>8</b>		<b>76,2</b>				
<b>16 H</b>		09.1984 → 01.1995	B (NA)	4	1598 cm <sup>3</sup> 2V	61-75 kW (83-102 PS) 9,6 87,60 mm
	IN/EX [4]	12,75 x 7.97 x 52,4	G1			058923 <b>81-88003</b>
<b>9</b>		<b>77</b>				
<b>TUD 5</b>		12.1994 → 12.1998	D (NA)	4	1527 cm <sup>3</sup> 2V	42 kW (57 PS) 23 82,00 mm
94 642 7..						
Fortsetzung nächste Seite / continued on next page / suite page suivante / continuación página próxima / Продолжение на следующей странице						

**R**

					Reference	Item No.
	IN [2] EX [2]	37,0 x 7 x 108,4 31,6 x 7 x 108,2	S - - A - Cr -	- 45° - - - 45° - -	9 - 9 -	<b>537627</b> <b>537628</b>
	[50]	∅ 7 mm				<b>KK-7H</b>
<b>10</b>		<b>80</b>				
<b>18 K4F</b>	08.1999 → 05.2005	B (NA)	4	1796 cm <sup>3</sup>	4V 85-88 kW (116-120 PS)	10,5 89,30 mm
<b>18 K4K</b>	11.1995 → 05.2005	B (NA)	4	1796 cm <sup>3</sup>	4V 107-110 kW (146-150 PS)	10,5 89,30 mm
<b>K 16-1.6</b>	05.1995 → 03.2000	B	4	1588 cm <sup>3</sup>	4V 82 kW (111 PS)	10,5:1 79,00 mm
	IN/EX [4]	9,88 x 6.01 x 30,0	G1		WAM 1452	<b>81-88000</b>
<b>11</b>		<b>80</b>				
<b>XUD 7TE</b>	09.1991 → 11.2000	D (A)	4	1769 cm <sup>3</sup>	2V 64-65 kW (87-88 PS)	22 88,00 mm
	IN [2] EX [2]	38,5 x 8 x 112,4 33,0 x 8 x 112,0	S - - A - Cr -	- 45° - - - 45° - -	1 - III 1 -	<b>531005</b> <b>537450</b> (1)
	(1)	Ventilsitz/valve seat/siège de soupape/asiento de válvula/седло клапана 3,8 mm				
	[50]	∅ 8 mm			LGN10005	<b>KK-8H</b>
	IN/EX [4]	14,05 x 8 x 48,0	B1			<b>81-5326</b>
		491 mm				<b>50 006 220</b> (2)
	(2)	Schalenhartguss/chilled cast iron/pièce moulée trempée en surface/fundición en coquilla/Отливка с отбеленным поверхностным слоем				
<b>12</b>		<b>84</b>				
<b>M 47 R</b>	08.2001 → 05.2005	D (LA)	4	1950 cm <sup>3</sup>	4V 85 kW (116 PS)	19,5 88,00 mm
	IN/EX [6]	11,54 x 6 x 39,0	B1			<b>81-11116</b>
<b>13</b>		<b>84</b>				
<b>M47 D20R</b>		D (A)	4	1951 cm <sup>3</sup>	4V 85 kW (116 PS)	19,5:1 88,00 mm
	IN/EX [2]	25,9 x 6 x 99,9	RA/S- Cr -	- 45° - VS -	22 - III	LGH101450 <b>111113</b>
	[50]	∅ 6 mm				<b>MK-6H</b>
	IN/EX [6]	11,54 x 6 x 39,0	B1			<b>81-11116</b>
	[8]	H 12 x 34,5 x 34,5				<b>50 006 414</b>
	[4]					<b>50 006 132</b>
<b>14</b>		<b>84,45</b>				
<b>O Series (110 kW)</b>		B (A)	4	1994 cm <sup>3</sup>	2V 110 kW (150 PS)	9:1 88,90 mm
	IN/EX [4]	12,08 x 7.49 x 38,9	G1		CAM5821	<b>81-88005</b>

					Reference	Item No.	
<b>15</b>	<b>84,45</b>						
<b>Prima 80 T</b>	09.1988 → 12.1993	D	(A)	4	1994 cm <sup>3</sup> 2V	60 kW (82 PS) 16,5:1 88,90 mm	
	IN/EX [4] 12,08 x 7.49 x 38,9	G1				CAM5821 <b>81-88005</b>	
<b>16</b>	<b>84,5</b>						
<b>20 H</b>	10.1984 → 10.1994	B	(NA)	4	1994 cm <sup>3</sup> 2V	75-86 kW (102-117 PS) 9,1:1 89,00 mm	
	IN/EX [4] 12,08 x 7.49 x 38,9	G1				CAM5821 <b>81-88005</b>	
<b>17</b>	<b>85</b>						
<b>F 18 A3</b>	03.1996 → 02.1999	B	(NA)	4	1850 cm <sup>3</sup> 4V	85 kW (115 PS) 9 81,50 mm	
<b>F 20 Z1</b>	08.1993 → 02.1999	B	(NA)	4	1997 cm <sup>3</sup> 4V	96 kW (131 PS) 9 88,00 mm	
<b>F 20 Z2</b>	08.1993 → 06.1996	B	(NA)	4	1997 cm <sup>3</sup> 4V	85 kW (115 PS) 9:1 88,00 mm	
<b>F20A</b>	09.1993 → 06.1996	B	(NA)	4	1997 cm <sup>3</sup> 4V	85-96 kW (116-131 PS) 9 88,00 mm	
	IN [2] 29,0 x 5,5 x 115,0	S	- Ni -	- 45° - VS -	1 - III	<b>V3816</b>	
	EX [4] 11,06 x 5.5 x 54,0	G1				<b>81-72001</b>	

Cyl.	mm	cm <sup>3</sup>	Comp. Ratio $\epsilon$	kW	PS	Pos		
AEE	B (NA) 4	76,5 x 86,9	1598	2	9,8	55	75	18
AEF	D (NA) 4	79,5 x 95,5	1896	2	22,5	47	64	40
AEG	B (NA) 4	82,5 x 92,8	1984	2	10,5	85	116	84
AEH	B (NA) 4	81 x 77,4	1595	2	10,3	74	101	65
AGN	B (NA) 4	81 x 86,4	1781	5	10,3	92	125	64
AGP	D (NA) 4	79,5 x 95,5	1896	2	19,5	50	68	43
AGR	D (LA) 4	79,5 x 95,5	1896	2	19,5	66	90	41
AGU	B (LA) 4	81 x 86,4	1781	5	9,5	110	150	66
AHF	D (LA) 4	79,5 x 95,5	1896	2	19,5	81	110	41
AKL	B (NA) 4	81 x 77,4	1595	2	10,2	74	101	65
ALH	D (LA) 4	79,5 x 95,5	1896	2	19,5	66	90	42
AMD	B (NA) 4	75,5 x 78	1397	2	10:1	44	60	17
AME	B (NA) 4	75,5 x 78	1397	2	10:1	50	68	17
AMF	D (A) 3	79,5 x 95,5	1422	2	19,5	55	75	48
AMX	B (NA) 6	82,5 x 86,4	2771	5	10,6	142	193	87
APK	B (NA) 4	82,5 x 92,8	1984	2	10,5	85	116	85
AQM	D (NA) 4	79,5 x 95,5	1896	2	19,5	50	68	44
AQW	B (NA) 4	75,5 x 78	1397	2	10:1	50	68	17
AQY	B (NA) 4	82,5 x 92,8	1984	2	10,5	85	116	85
ARX	B (LA) 4	81 x 86,4	1781	5	9,5	110	150	67
ARZ	B (LA) 4	81 x 86,4	1781	5	9,5	110	150	66
ASV	D (LA) 4	79,5 x 95,5	1896	2	19,5	81	110	42
ASY	D (NA) 4	79,5 x 95,5	1896	2	19,5	47	64	44
ASZ	D (LA) 4	79,5 x 95,5	1896	2	19	96	130	47
ATD	D (LA) 4	79,5 x 95,5	1896	2	19,5	74	100	45
ATZ	B (NA) 4	75,5 x 78	1397	2	10	50	68	17
AUA	B (NA) 4	76,5 x 75,6	1390	4	10,5	55	75	19
AUB	B (NA) 4	76,5 x 75,6	1390	4	10,5	74	100	21
AUM	B (LA) 4	81 x 86,4	1781	5	9,5	110	150	68
AUQ	B (A) 4	81 x 86,4	1781	5	9,5	132	180	68
AVB	D (LA) 4	79,5 x 95,5	1896	2	19	74	101	45
AVF	D (LA) 4	79,5 x 95,5	1896	2	19:1	96	130	47
AVU	B (NA) 4	81 x 77,4	1595	2	10,3	75	102	69
AWT	B (A) 4	81 x 86,4	1781	5	9,5	110	150	71
AWX	D (LA) 4	79,5 x 95,5	1896	2	19:1	96	130	47
AWY	B (NA) 3	76,5 x 86,9	1198	2	10,3	40	54	23
AXP	B (NA) 4	76,5 x 75,6	1390	4	10,5	55	75	22
AXR	D (LA) 4	79,5 x 95,5	1896	2	19	74	100	46
AYM	D (LA) 6	78,3 x 86,4	2496	4	18,5	120	163	39
AZE	B (NA) 4	75,5 x 78	1397	2	10	44	60	17
AZF	B (NA) 4	75,5 x 78	1397	2	10:1	44	60	17
AZH	B (NA) 4	82,5 x 92,8	1984	2	10,5	85	116	85
AZJ	B (NA) 4	82,5 x 92,8	1984	2	10,5	85	116	85
AZL	B (NA) 4	82,5 x 92,8	1984	2	10,5	85	116	86
AZM	B (NA) 4	82,5 x 92,8	1984	2	10,5	85	115	85
AZQ	B (NA) 3	76,5 x 86,9	1198	4	10,5	47	64	25
AZV	D (LA) 4	81 x 95,5	1968	4	18	100	136	74
BBG	B (NA) 6	82,5 x 86,4	2771	5	10,6	140	190	87
BBM	B (NA) 3	76,5 x 86,9	1198	2	10,5	44	60	24
BBY	B (NA) 4	76,5 x 75,6	1390	4	10,5	55	75	19
BBZ	B (NA) 4	76,5 x 75,6	1390	4	10,5	74	100	21
BCA	B (NA) 4	76,5 x 75,6	1390	4	10,5	55	75	22
BDG	D (LA) 6	78,3 x 86,4	2496	4	18,5	120	163	39
BFQ	B (NA) 4	81 x 77,4	1595	2	10,2	75	102	70
BGU Euro 4	B (NA) 4	81 x 77,4	1595	2	10,5	75	102	72
BJB	D (LA) 4	79,5 x 95,5	1896	2	19	77	105	50
BKC	D (LA) 4	79,5 x 95,5	1896	2	19	77	105	46
BKD	D (LA) 4	81 x 95,5	1968	4	18	103	140	74
BKY	B (NA) 4	76,5 x 75,6	1390	4	10,5	55	75	20
BLF	B (NA) 4	76,5 x 86,9	1598	4	12	85	115	26
BLR	B (NA) 4	82,5 x 92,8	1984	4	11,5	110	150	88
BLS	D (LA) 4	79,5 x 95,5	1896	2	19:1	77	105	51
BLT	D (LA) 4	79,5 x 95,5	1896	2	19	96	130	49
BLX	B (NA) 4	82,5 x 92,8	1984	4	11,5	110	150	88
BLY	B (NA) 4	82,5 x 92,8	1984	4	11,5	110	150	88
BMD	B (NA) 3	76,5 x 86,9	1198	2	10,3	40	54	24
BME	B (NA) 3	76,5 x 86,9	1198	4	10,5	47	64	25
BMM	D (LA) 4	81 x 95,5	1968	2	18,5:1	103	140	77
BMN	D (LA) 4	81 x 95,5	1968	4	18,5	125	170	79

S



KOLBENSCHMIDT

**SKODA**

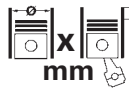
			Cyl.	 mm	cm <sup>3</sup>		Comp. Ratio $\epsilon$	kW	PS	Pos
BMP	D (LA)	4		81 x 95,5	1968	2	18,5	103	140	80
BMS	D (LA)	3		79,5 x 95,5	1422	2	19,5	59	80	55
BNM	D (LA)	3		79,5 x 95,5	1422	2	19,5	51	70	54
BNV	D (LA)	3		79,5 x 95,5	1422	2	19,5	59	80	54
BPZ	D (LA)	4		79,5 x 95,5	1896	2	19	85	115	53
BSE Euro 4/5	B (NA)	4		81 x 77,4	1595	2	10,5	75	102	73
BSF Euro 2	B (NA)	4		81 x 77,4	1595	2	10,5	75	102	73
BSS	D (LA)	4		81 x 95,5	1968	2	18,5:1	103	140	76
BSV	D (LA)	4		79,5 x 95,5	1896	2	19	77	105	53
BSW	D (LA)	4		79,5 x 95,5	1896	2	18,5:1	77	105	56
BTS	B (NA)	4		76,5 x 86,9	1598	4	10,5	77	105	28
BUD	B (NA)	4		76,5 x 75,6	1390	4	10,5	59	80	22
BVX	B (NA)	4		82,5 x 92,8	1984	4	11,5	110	150	88
BVY	B (NA)	4		82,5 x 92,8	1984	4	11,5	110	150	88
BVZ	B (NA)	4		82,5 x 92,8	1984	4	11,5	110	150	88
BWA	B (LA)	4		82,5 x 92,8	1984	4	10,3	147	200	89
BWW	D (LA)	4		81 x 95,5	1968	2		91	124	78
BXE	D (LA)	4		79,5 x 95,5	1896	2	19	77	105	52
BXW	B (NA)	4		76,5 x 75,6	1390	4	10,5:1	63	86	29
BZB	B (A)	4		82,5 x 84,2	1798	4	9,6	118	160	91
BZG	B (NA)	3		76,5 x 86,9	1198	4	10,5	51	70	25
CAVE	B (A)	4		76,5 x 75,6	1390	4	10	132	180	33
CAXA Euro 5	B (LA)	4		76,5 x 75,6	1390	4	10	90	122	32
CAXC	B (LA)	4		76,5 x 75,6	1390	4	10	92	125	32
CAYA	D (LA)	4		79,5 x 80,5	1598	4	16,5	55	75	59
CAYB Euro 5	D (LA)	4		79,5 x 80,5	1598	4	16,5	66	90	57
CAYC	D (LA)	4		79,5 x 80,5	1598	4	16,5	77	105	57
CBBB	D (LA)	4		81 x 95,5	1968	4	16,5	125	170	75
CBDB	D (A)	4		81 x 95,5	1968	4	16,5	103	140	75
CBZA	B (A)	4		71 x 75,6	1197	2	10	63	86	1
CBZB Euro 5	B (A)	4		71 x 75,6	1197	2	10	77	105	1
CCSA Euro 4/5	B (NA)	4		81 x 77,4	1595	2	10,5	75	102	73
CCZA	B (LA)	4		82,5 x 92,8	1984	4	9,6	147	200	90
CDAA	B (A)	4		82,5 x 84,1	1798	4	9,6	118	160	92
CDAB	B (LA)	4		82,5 x 84,1	1798	4	9,6	112	152	93
CDVA Euro 5	B (NA)	6		89 x 96,4	3597	4	11,4	191	260	102
CEAA	B (A)	4		82,5 x 84,2	1798	4	0	118	160	101
CEGA	D (A)	4		81 x 95,5	1968	4	16,5	125	170	75
CEVA	B (NA)	3		76,5 x 86,9	1198	4	10,5:1	51	70	31
CFFB	D (LA)	4		81 x 95,5	1968	4	18,5	103	140	75
CFGB	D (LA)	4		81 x 95,5	1968	4	16,5	125	170	75
CFHA	D (A)	4		81 x 95,5	1968	4	16,5	81	110	81
CFHC	D (A)	4		81 x 95,5	1968	4	16,5	103	140	75
CFHF	D (A)	4		81 x 95,5	1968	4	16,5	81	110	75
CFJA	D (A)	4		81 x 95,5	1968	4	16,5	125	170	75
CFNA Euro 4	B (NA)	4		76,5 x 86,9	1598	4	10,5	77	105	30
CFWA	D (A)	3		79,5 x 80,5	1199	4	16,5	55	75	58
CGGA	B (NA)	4		76,5 x 75,6	1390	4	10,5	59	80	27
CGGB Euro 5	B (NA)	4		76,5 x 75,6	1390	4	10,5:1	63	85	22
CGMA	B (A)	4		82,5 x 92,8	1984	4	0	147	200	101
CGPA	B (NA)	3		76,5 x 86,9	1198	4	10,5	51	70	25
CGPB	B (NA)	3		76,5 x 86,9	1198	4	10,5	44	60	25
CGPC	B (NA)	3		76,5 x 86,9	1198	4	10,5	55	75	36
CHFA	B (NA)	3		76,5 x 86,9	1198	2	10,5	44	60	24
CHGA	BG (NA)	4		81 x 77,4	1595	2		75	102	63
CHHA	B (LA)	4		82,5 x 92,8	1984	4	9,6	169	230	99
CHHB Euro 6	B (LA)	4		82,5 x 92,8	1984	4	9,6	162	220	94
CHPA Euro 5	B (LA)	4		74,5 x 80	1395	4	10,5	103	140	11
CHPB Euro 6	B (LA)	4		74,5 x 80	1395	4	10	110	150	11
CHTA	B (NA)	3		76,5 x 86,9	1198	4	10,5	51	70	31
CHYA Filter	B (NA)	3		74,5 x 76,4	999	4		44	60	10
CHYB Filter	B (NA)	3		74,5 x 76,4	999	4	10,5	55	75	10
CHZB Euro 6	B (A)	3		74,5 x 76,4	999	4	10,5	70	95	12
CHZC Euro 6	B (A)	3		74,5 x 76,4	999	4	10,5	81	110	12
CHZD	B (LA)	3		74,5 x 76,4	999	4	10,5	85	115	14
CHZJ	B (A)	3		74,5 x 76,4	999	4		85	115	15
CJLA	B (NA)	3		76,5 x 86,9	1198	4		55	75	35
CJSA Euro 6	B (LA)	4		82,5 x 84,1	1798	4	9,6	132	180	95
CJSB Euro 6	B (LA)	4		82,5 x 84,1	1798	4	9,6	132	180	95

**S**

			Cyl.		mm	cm <sup>3</sup>	Comp. Ratio $\epsilon$	kW	PS	Pos
CJSC Euro 6	B (LA)	4	82,5 x 84,1	1798	4	9,6	132	180	96	
CJXA	B (A)	4	82,5 x 92,8	1984	4		206	280	97	
CJZA Euro 6	B (LA)	4	71 x 75,6	1197	4	10,5	77	105	2	
CJZB Euro 5	B (LA)	4	71 x 75,6	1197	4	10,5	63	86	3	
CJZC Euro 6	B (A)	4	71 x 75,6	1197	4	10,5	66	90	5	
CJZD Euro 6	B (LA)	4	71 x 75,6	1197	4	10,5	81	110	6	
CKFB Euro 6	D (LA)	4	81 x 95,5	1968	4		105	143	81	
CKFC Euro 5	D (LA)	4	81 x 95,5	1968	4	16	110	150	81	
CLCA	D (LA)	4	81 x 95,5	1968	4	16,5	81	110	75	
CLCB	D (A)	4	81 x 95,5	1968	4	16,5	103	140	75	
CLHA Euro 5	D (LA)	4	79,5 x 80,5	1598	4	16,2	77	105	59	
CLHB Euro 5	D (LA)	4	79,5 x 80,5	1598	4	16,2	66	90	59	
CLJA	D (LA)	4	81 x 95,5	1968	4	18,5	103	140	75	
CLNA Euro 5	D (LA)	4	79,5 x 80,5	1598	4	16,5	77	105	57	
CLSA	B (NA)	4	76,5 x 86,9	1598	4	10,5	77	105	30	
CMXA Euro 5	B (NA)	4	81 x 77,4	1595	2	10,5	75	102	70	
CPGA Euro 5	BG (NA)	3	74,5 x 76,4	999	4	11,5	50	68	16	
CPWA	BG (A)	4	74,5 x 80	1395	4	10,5	81	110	8	
CRGA Euro 4	D (LA)	4	81 x 95,5	1968	4	15,5	130	177	82	
CRKB Filter	D (LA)	4	79,5 x 80,5	1598	4	16,2	81	110	59	
CRLB Euro 6	D (LA)	4	81 x 95,5	1968	4	16,2	110	150	82	
CRMB Euro 6	D (LA)	4	81 x 95,5	1968	4	16,2	110	150	81	
CRVC Euro 4	D (LA)	4	81 x 95,5	1968	4	16	105	143	81	
CTHE	B (A)	4	76,5 x 75,6	1390	4	10	132	180	34	
CUNA Euro 6	D (LA)	4	81 x 95,5	1968	4	15,8	135	184	81	
CUPA	D (A)	4	81 x 95,5	1968	4		135	184	81	
CUSA Euro 6	D (LA)	3	79,5 x 95,5	1422	4	16,2	55	75	60	
CUSB Euro 6	D (LA)	3	79,5 x 95,5	1422	4	16,2	66	90	60	
CUTA Euro 6	D (LA)	3	79,5 x 95,5	1422	4	16,2	77	105	60	
CUUA	D (A)	4	81 x 95,5	1968	4		81	110	82	
CUUB	D (A)	4	81 x 95,5	1968	4		110	150	82	
CWVA Euro 5	B (NA)	4	76,5 x 86,9	1598	4	10,5	81	110	37	
CWVB Euro 5	B (NA)	4	76,5 x 86,9	1598	4		66	90	37	
CXXA Euro 6	D (LA)	4	79,5 x 80,5	1598	4	16,2	66	90	60	
CXXB Euro 6	D (LA)	4	79,5 x 80,5	1598	4	16,2	81	110	60	
CYKA	D (LA)	4	81 x 95,5	1968	4	0	110	150	82	
CYVA Euro 6	B (LA)	4	71 x 75,6	1197	4	10,5	63	86	4	
CYVB	B (LA)	4	71 x 75,6	1197	4	10,5	81	110	7	
CZCA Euro 6	B (LA)	4	74,5 x 80	1395	4	10	92	125	12	
CZDA Euro 6	B (LA)	4	74,5 x 80	1395	4	10	110	150	12	
CZEA Euro 6	B (LA)	4	74,5 x 80	1395	4	10	110	150	13	
CZPA Euro 6	B (A)	4	82,5 x 92,8	1984	4	11,65	132	180	100	
DAFA	B (NA)	3	74,5 x 76,4	999	4		44	60	13	
DBGA Euro 5	D (LA)	4	81 x 95,5	1968	4	16,2	110	150	82	
DBGC Euro 5	D (A)	4	81 x 95,5	1968	4	16,2	110	150	82	
DBKA Euro 6	D (LA)	4	79,5 x 80,5	1598	4	16,2	81	110	62	
DBYA	BG (A)	3	74,5 x 76,4	999	4		66	90	9	
DCYA Euro 6	D (LA)	4	81 x 95,5	1968	4	16,2	110	150	82	
DDAA	D (A)	4	81 x 95,5	1968	4	15,8	140	190	83	
DDYA Euro 6	D (LA)	4	79,5 x 80,5	1598	4	16,2	85	115	61	
DDYB Euro 6	D (LA)	4	79,5 x 80,5	1598	4	16,2	66	90	61	
DFCA	D (A)	4	81 x 95,5	1968	4	15,5	140	190	82	
DFEA Euro 6	D (LA)	4	81 x 95,5	1968	4	16,2	110	150	82	
DFGA Euro 6	D (LA)	4	81 x 95,5	1968	4	16,2	110	150	82	
DFHA Euro 6	D (LA)	4	81 x 95,5	1968	4	15,5-16,2	140	190	82	
DFSA	D (A)	4	81 x 95,5	1968	4		81	110	82	
DFSB	D (A)	4	81 x 95,5	1968	4		110	150	82	
DGTE Euro 6	D (LA)	4	79,5 x 80,5	1598	4		85	115	61	
DJGA Euro 6	D (LA)	4	81 x 95,5	1968	4	16,2	135	184	83	
DKLA	B (A)	3	74,5 x 76,4	999	4		70	95	15	
DKRF Euro 6	B (LA)	3	74,5 x 76,4	999	4		85	115	15	
DKTB Euro 6	B (LA)	4	82,5 x 92,8	1984	4		180	245	97	
DKZA Euro 6	B (LA)	4	82,5 x 92,8	1984	4		140	190	100	
DLBA	B (A)	4	82,5 x 92,8	1984	4		180	245	98	
DNUA	B (LA)	4	82,5 x 92,8	1984	4		200	272	98	

S



					Pos						Pos	
<b>CITIGO (NF1)</b>												
1.0	10.2011 → 08.2019	CHYA	B	10	1.4 16V	04.2006 → 12.2007	BUD	B	22			
1.0	10.2011 → 08.2019	CHYB	B	10	1.4 TDI	04.2003 → 12.2007	AMF	D	48			
1.0 CNG	11.2012 → 08.2019	CPGA	BG	16	1.4 TDI	10.2005 → 12.2007	BNM	D	54			
<b>FABIA I (6Y2)</b>												
1.2	07.2001 → 04.2007	AWY	B	23	1.4 TDI	10.2005 → 12.2007	BNV	D	54			
1.2	07.2001 → 04.2007	BMD	B	24	1.9 SDI	11.1999 → 12.2007	ASY	D	44			
1.2	01.2003 → 03.2008	AZQ	B	25	1.9 TDI	01.2000 → 12.2007	ATD	D	45			
1.2	01.2003 → 03.2008	BME	B	25	1.9 TDI	01.2000 → 12.2007	AXR	D	46			
1.4	08.1999 → 05.2003	AME	B	17	2.0	12.1999 → 12.2007	AZL	B	86			
1.4	08.1999 → 05.2003	AQW	B	17	<b>FABIA II (542)</b>							
1.4	08.1999 → 05.2003	ATZ	B	17	1.2	12.2006 → 12.2014	BBM	B	24			
1.4	08.2000 → 08.2002	AZE	B	17	1.2	12.2006 → 12.2014	CHFA	B	24			
1.4	08.2000 → 08.2002	AZF	B	17	1.2	01.2007 → 12.2014	BZG	B	25			
1.4	02.2006 → 10.2006	BUD	B	22	1.2	01.2007 → 12.2014	CEVA	B	31			
1.4 16V	12.1999 → 03.2008	AUA	B	19	1.2	01.2007 → 12.2014	CGPA	B	25			
1.4 16V	12.1999 → 03.2008	AUB	B	21	1.2	01.2007 → 12.2014	CHTA	B	31			
1.4 16V	12.1999 → 03.2008	BBY	B	19	1.2 12V	10.2010 → 12.2014	CJLA	B	35			
1.4 16V	12.1999 → 03.2008	BBZ	B	21	1.2 12V	11.2011 → 12.2014	CGPB	B	25			
1.4 16V	12.1999 → 03.2008	BKY	B	20	1.2 LPG	07.2007 → 11.2014	CGPA	B	25			
1.4 TDI	04.2003 → 03.2008	AMF	D	48	1.2 LPG	03.2009 → 11.2011	CHFA	B	24			
1.4 TDI	10.2005 → 03.2008	BNM	D	54	1.2 TDI	05.2010 → 12.2014	CFWA	D	58			
1.4 TDI	10.2005 → 03.2008	BNV	D	54	1.2 TDI	03.2010 → 12.2014	CBZA	B	1			
1.9 SDI	12.1999 → 03.2008	ASY	D	44	1.2 TSI	03.2010 → 12.2014	CBZB	B	1			
1.9 TDI	01.2000 → 03.2008	ATD	D	45	1.4	01.2007 → 12.2014	BXW	B	29			
1.9 TDI	01.2000 → 03.2008	AXR	D	46	1.4	01.2007 → 12.2014	CGGB	B	22			
1.9 TDI RS	06.2003 → 03.2008	ASZ	D	47	1.4 LPG	01.2007 → 11.2014	BXW	B	29			
1.9 TDI RS	06.2003 → 03.2008	BLT	D	49	1.4 LPG	01.2007 → 11.2014	CGGB	B	22			
2.0	12.1999 → 03.2008	AZL	B	86	1.4 TDI	01.2007 → 03.2010	BMS	D	55			
<b>FABIA I Combi (6Y5)</b>												
1.2	07.2001 → 12.2007	AWY	B	23	1.4 TDI	01.2007 → 03.2010	BNV	D	54			
1.2	07.2001 → 12.2007	BMD	B	24	1.4 TDI	02.2007 → 03.2010	BNM	D	54			
1.2	01.2003 → 12.2007	AZQ	B	25	1.4 TSI RS	05.2010 → 12.2014	CAVE	B	33			
1.2	01.2003 → 12.2007	BME	B	25	1.4 TSI RS	05.2010 → 12.2014	CTHE	B	34			
1.4	04.2000 → 03.2003	AZE	B	17	1.6	04.2007 → 12.2014	BTS	B	28			
1.4	04.2000 → 03.2003	AZF	B	17	1.6	04.2007 → 12.2014	CFNA	B	30			
1.4	04.2000 → 05.2003	AME	B	17	1.6	04.2007 → 12.2014	CLSA	B	30			
1.4	04.2000 → 05.2003	AQW	B	17	1.6 TDI	03.2010 → 12.2014	CAYB	D	57			
1.4	04.2000 → 05.2003	ATZ	B	17	1.6 TDI	03.2010 → 12.2014	CAYC	D	57			
1.4 16V	04.2000 → 12.2007	AUB	B	21	1.6 TDI	04.2010 → 12.2014	CAYA	D	59			
1.4 16V	04.2000 → 12.2007	BBZ	B	21	1.9 TDI	04.2007 → 03.2010	BLS	D	51			
1.4 16V	05.2000 → 12.2007	AUA	B	19	1.9 TDI	04.2007 → 03.2010	BSW	D	56			
1.4 16V	05.2000 → 12.2007	BBY	B	19	<b>FABIA II Combi (545)</b>							
1.4 16V	05.2000 → 12.2007	BKY	B	20	1.2	10.2007 → 11.2014	BBM	B	24			
1.4 16V	05.2000 → 12.2007	BUD	B	22	1.2	10.2007 → 11.2014	CHFA	B	24			
1.4 TDI	04.2006 → 12.2007	BUD	B	22	1.2	10.2007 → 12.2014	BZG	B	25			
1.4 TDI	04.2003 → 12.2007	AMF	D	48	1.2	10.2007 → 12.2014	CEVA	B	31			
1.4 TDI	10.2005 → 12.2007	BNM	D	54	1.2	10.2007 → 12.2014	CGPA	B	25			
1.4 TDI	10.2005 → 12.2007	BNV	D	54	1.2	10.2007 → 12.2014	CHTA	B	31			
1.9 SDI	04.2000 → 12.2007	ASY	D	44	1.2 12V	11.2011 → 12.2014	CGPB	B	25			
1.9 TDI	04.2000 → 12.2007	ATD	D	45	1.2 LPG	10.2007 → 11.2014	CGPA	B	25			
1.9 TDI	04.2000 → 12.2007	AXR	D	46	1.2 LPG	03.2009 → 11.2011	CHFA	B	24			
2.0	04.2000 → 12.2007	AZL	B	86	1.2 TDI	05.2010 → 12.2014	CFWA	D	58			
<b>FABIA I Saloon (6Y3)</b>												
1.2	07.2001 → 12.2007	AWY	B	23	1.2 TSI	03.2010 → 12.2014	CBZA	B	1			
1.2	07.2001 → 12.2007	BMD	B	24	1.2 TSI	03.2010 → 12.2014	CBZB	B	1			
1.2	01.2003 → 12.2007	AZQ	B	25	1.4	10.2007 → 12.2014	BXW	B	29			
1.2	01.2003 → 12.2007	BME	B	25	1.4	10.2007 → 12.2014	CGGB	B	22			
1.4	04.2000 → 08.2002	AZE	B	17	1.4 LPG	10.2007 → 11.2014	BXW	B	29			
1.4	04.2000 → 08.2002	AZF	B	17	1.4 LPG	10.2007 → 11.2014	CGGB	B	22			
1.4	07.2001 → 05.2003	AME	B	17	1.4 TDI	10.2007 → 03.2010	BMS	D	55			
1.4	07.2001 → 05.2003	AQW	B	17	1.4 TDI	10.2007 → 03.2010	BNM	D	54			
1.4	07.2001 → 05.2003	ATZ	B	17	1.4 TDI	10.2007 → 03.2010	BNV	D	54			
1.4 16V	10.1999 → 12.2007	AUA	B	19	1.4 TSI RS	05.2010 → 12.2014	CAVE	B	33			
1.4 16V	10.1999 → 12.2007	BBY	B	19	1.4 TSI RS	05.2010 → 12.2014	CTHE	B	34			
1.4 16V	10.1999 → 12.2007	BKY	B	20	1.6	10.2007 → 12.2014	BTS	B	28			
1.4 16V	12.1999 → 12.2007	AUB	B	21	1.6	10.2007 → 12.2014	CFNA	B	30			
1.4 16V	12.1999 → 12.2007	BBZ	B	21	1.6 TDI	03.2010 → 12.2014	CAYB	D	57			
1.4 16V	12.1999 → 12.2007	BBZ	B	21	1.6 TDI	03.2010 → 12.2014	CAYC	D	57			
					<b>FABIA III (NJ3)</b>							

S

				Pos					Pos
1.0	08.2014 →	CHYA	B	10	1.4 TSI	10.2016 →	CZDA	B	12
1.0	08.2014 →	CHYB	B	10	1.4 TSI	10.2016 →	CZEA	B	13
1.0 TSI	08.2014 →	CHZB	B	12	1.4 TSI 4x4	10.2016 →	CZDA	B	12
1.0 TSI	08.2014 →	CHZC	B	12	1.4 TSI 4x4	10.2016 →	CZEA	B	13
1.2 TSI	08.2014 →	CJZC	B	5	2.0 TDI	10.2016 →	DBGA	D	82
1.2 TSI	08.2014 →	CJZD	B	6	2.0 TDI	10.2016 →	DBGC	D	82
1.4 TDI	08.2014 →	CUSB	D	60	2.0 TDI	10.2016 →	DFGA	D	82
1.4 TDI	08.2014 →	CUTA	D	60	2.0 TDI 4x4	10.2016 →	DBGA	D	82
1.4 TDI	05.2015 →	CUSA	D	60	2.0 TDI 4x4	10.2016 →	DBGC	D	82
1.4 TSI R5	02.2018 →	CZCA	B	12	2.0 TDI 4x4	10.2016 →	DFGA	D	82
1.6	08.2014 →	CWVB	B	37	2.0 TDI 4x4	10.2016 →	DFHA	D	82
1.6	01.2015 →	CWVA	B	37	2.0 TSI 4x4	10.2016 →	CZPA	B	100
<b>FABIA III Estate (NJ5)</b>					2.0 TSI 4x4	02.2019 →	DKZA	B	100
1.0	10.2014 →	CHYA	B	10	<b>OCTAVIA I (1U2)</b>				
1.0	10.2014 →	CHYB	B	10	1.4	04.1999 → 03.2001	AMD	B	17
1.0 TSI	08.2014 →	CHZB	B	12	1.4 16V	09.2000 → 12.2010	AXP	B	22
1.0 TSI	08.2014 →	CHZC	B	12	1.4 16V	09.2000 → 12.2010	BCA	B	22
1.2 TSI	10.2014 →	CJZC	B	5	1.6	09.1996 → 09.2004	AEE	B	18
1.2 TSI	10.2014 →	CJZD	B	6	1.6	02.1997 → 12.2007	AEH	B	65
1.4 TDI	10.2014 →	CUSB	D	60	1.6	02.1997 → 12.2007	AKL	B	65
1.4 TDI	10.2014 →	CUTA	D	60	1.6	11.2000 → 12.2010	AVU	B	69
1.4 TDI	05.2015 →	CUSA	D	60	1.6	11.2000 → 12.2010	BFQ	B	70
1.6	10.2014 →	CWVB	B	37	1.8	09.1996 → 07.2000	AGN	B	64
1.6	01.2015 →	CWVA	B	37	1.8 T	08.1997 → 12.2010	AGU	B	66
<b>FABIA SCOUT</b>					1.8 T	08.1997 → 12.2010	ARX	B	67
1.2 TDI	03.2010 →	CFWA	D	58	1.8 T	08.1997 → 12.2010	ARZ	B	66
1.2i	03.2010 →	CBZA	B	1	1.8 T	08.1997 → 12.2010	AUM	B	68
1.2i	03.2010 →	CBZB	B	1	1.8 T 4x4	05.2001 → 05.2006	ARX	B	67
1.4 TDI	05.2009 → 03.2010	BMS	D	55	1.9 SDI	06.1997 → 12.2003	AGP	D	43
1.4 TDI	05.2009 → 03.2010	BNV	D	54	1.9 SDI	06.1997 → 12.2003	AQM	D	44
1.4i 16V	05.2009 → 03.2010	BXW	B	29	1.9 TDI	09.1996 → 03.2010	AGR	D	41
1.4i 16V	03.2010 → 03.2010	CGGB	B	22	1.9 TDI	09.1996 → 03.2010	ALH	D	42
1.6 TDI 16V	03.2010 →	CAYB	D	57	1.9 TDI	08.1997 → 01.2006	AHF	D	41
1.6 TDI 16V	03.2010 →	CAYC	D	57	1.9 TDI	08.1997 → 01.2006	ASV	D	42
1.6i 16V	05.2009 → 03.2010	BTS	B	28	1.9 TDI	01.2003 → 09.2004	ASZ	D	47
1.9 TDI	05.2009 → 03.2010	BLS	D	51	1.9 TDI	10.2005 → 12.2010	AXR	D	46
1.9 TDI	05.2009 → 03.2010	BSW	D	56	2.0	04.1999 → 05.2007	AEG	B	84
<b>FELICIA I (6U1)</b>					2.0	04.1999 → 05.2007	APK	B	85
1.6 LX	08.1995 → 03.1998	AEE	B	18	2.0	04.1999 → 05.2007	AQY	B	85
1.9 D	10.1995 → 03.1998	AEF	D	40	2.0	04.1999 → 05.2007	AZH	B	85
<b>FELICIA I Estate (6U5)</b>					2.0	04.1999 → 05.2007	AZJ	B	85
1.6 GLX	08.1995 → 03.1998	AEE	B	18	RS 1.8 T	05.2001 → 01.2006	AUQ	B	68
1.9 D	10.1995 → 03.1998	AEF	D	40	<b>OCTAVIA I Combi (1U5)</b>				
<b>FELICIA I Pickup (6UF, 6U7)</b>					1.4 16V	08.2000 → 12.2010	AXP	B	22
1.6	06.1997 → 04.2002	AEE	B	18	1.4 16V	08.2000 → 12.2010	BCA	B	22
1.9 D	06.1997 → 04.2002	AEF	D	40	1.6	07.1998 → 09.2004	AEE	B	18
<b>FELICIA II (6U1)</b>					1.6	07.1998 → 12.2007	AEH	B	65
1.6	01.1998 → 06.2001	AEE	B	18	1.6	07.1998 → 12.2007	AKL	B	65
1.9 D	01.1998 → 06.2001	AEF	D	40	1.6	09.2000 → 12.2010	AVU	B	69
<b>FELICIA II Estate (6U5)</b>					1.6	09.2000 → 12.2010	BFQ	B	70
1.6	01.1998 → 06.2001	AEE	B	18	1.8 20V	07.1998 → 07.2000	AGN	B	64
1.9 D	01.1998 → 06.2001	AEF	D	40	1.8 T	07.1998 → 12.2010	AGU	B	66
<b>KAMIQ (NW4)</b>					1.8 T	07.1998 → 12.2010	ARX	B	67
1.0 TGI CNG	11.2019 →	DBYA	BG	9	1.8 T	07.1998 → 12.2010	ARZ	B	66
1.0 TSI	07.2019 →	DKLA	B	15	1.8 T	07.1998 → 12.2010	AUM	B	68
1.0 TSI	07.2019 →	DKRF	B	15	1.8 T 4x4	05.2001 → 05.2006	ARX	B	67
1.6 SRE	07.2019 →	CWVA	B	37	1.9 SDI	07.1998 → 12.2003	AGP	D	43
<b>KAROQ (NU7)</b>					1.9 SDI	07.1998 → 12.2003	AQM	D	44
1.0 TSI	07.2017 →	CHZJ	B	15	1.9 TDI	07.1998 → 01.2006	AHF	D	41
1.0 TSI	07.2017 →	DKRF	B	15	1.9 TDI	07.1998 → 01.2006	ASV	D	42
1.4 TSI	09.2019 →	CZEA	B	13	1.9 TDI	07.1998 → 03.2010	AGR	D	41
1.6 SRE	06.2020 →	CWVA	B	37	1.9 TDI	07.1998 → 03.2010	ALH	D	42
1.6 TDI	07.2017 →	DDYA	D	61	1.9 TDI	08.2000 → 12.2010	AXR	D	46
1.6 TDI	07.2017 →	DGTE	D	61	1.9 TDI	01.2003 → 09.2004	ASZ	D	47
2.0 TDI 4x4	07.2017 →	DFHA	D	82	1.9 TDI 4x4	11.1999 → 02.2006	AGR	D	41
2.0 TDI 4x4	07.2018 →	CRVC	D	81	1.9 TDI 4x4	09.2000 → 01.2006	ATD	D	45
2.0 TSI 4x4	04.2019 →	DKZA	B	100	2.0	04.1999 → 05.2007	AEG	B	84
<b>KODIAQ (NS7, NV7)</b>					2.0	04.1999 → 05.2007	APK	B	85
1.4 TSI	10.2016 →	CZCA	B	12	2.0	04.1999 → 05.2007	AQY	B	85

S

				Pos					Pos
2.0	04.1999 → 05.2007	AZH	B	85	1.9 TDI	09.2004 → 12.2010	BXE	D	52
2.0	04.1999 → 05.2007	AZJ	B	85	1.9 TDI 4x4	11.2004 → 12.2010	BKC	D	46
2.0 4x4	08.2000 → 09.2004	AZH	B	85	1.9 TDI 4x4	11.2004 → 12.2010	BLS	D	51
2.0 4x4	08.2000 → 09.2004	AZJ	B	85	1.9 TDI 4x4	11.2004 → 12.2010	BXE	D	52
RS 1.8 T	08.2002 → 01.2006	AUQ	B	68	2.0 FSI	11.2004 → 10.2008	BLR	B	88
<b>OCTAVIA II (1Z3)</b>					2.0 FSI	11.2004 → 10.2008	BLY	B	88
1.2 TSI	02.2010 → 06.2013	CBZB	B	1	2.0 FSI	11.2004 → 10.2008	BVY	B	88
1.4	05.2004 → 05.2006	BCA	B	22	2.0 FSI	11.2004 → 10.2008	BVZ	B	88
1.4	06.2004 → 04.2013	BUD	B	22	2.0 FSI 4x4	11.2004 → 04.2009	BLX	B	88
1.4	06.2004 → 04.2013	CGGA	B	27	2.0 FSI 4x4	11.2004 → 04.2009	BLY	B	88
1.4 TSI	11.2008 → 06.2013	CAXA	B	32	2.0 FSI 4x4	11.2004 → 04.2009	BVX	B	88
1.6	06.2004 → 06.2013	BGU	B	72	2.0 RS	10.2005 → 02.2013	BWA	B	89
1.6	06.2004 → 06.2013	BSE	B	73	2.0 RS	10.2005 → 02.2013	CCZA	B	90
1.6	06.2004 → 06.2013	BSF	B	73	2.0 TDI	11.2005 → 05.2010	BMM	D	77
1.6	06.2004 → 06.2013	CCSA	B	73	2.0 TDI	03.2010 → 06.2013	CFHF	D	75
1.6	06.2004 → 06.2013	CMXA	B	70	2.0 TDI	03.2010 → 06.2013	CLCA	D	75
1.6 FSI	02.2004 → 10.2008	BLF	B	26	2.0 TDI 16V	02.2004 → 05.2010	AZV	D	74
1.6 LPG	08.2009 → 11.2012	BSE	B	73	2.0 TDI 16V	02.2004 → 05.2013	BKD	D	74
1.6 LPG	08.2009 → 11.2012	CHGA	BG	63	2.0 TDI 16V	02.2004 → 05.2013	CFHC	D	75
1.6 MultiFuel	01.2008 → 06.2013	CCSA	B	73	2.0 TDI 16V	02.2004 → 05.2013	CLCB	D	75
1.6 MultiFuel	01.2008 → 06.2013	CMXA	B	70	2.0 TDI 16V 4x4	05.2010 → 02.2013	BKD	D	74
1.6 TDI	06.2009 → 04.2013	CAYC	D	57	2.0 TDI 16V 4x4	05.2010 → 02.2013	CFHC	D	75
1.8 TSI	06.2007 → 04.2013	BZB	B	91	2.0 TDI 16V 4x4	05.2010 → 02.2013	CLCB	D	75
1.8 TSI	06.2007 → 04.2013	CDAA	B	92	2.0 TDI 4x4	07.2006 → 05.2010	BMM	D	77
1.8 TSI	03.2009 → 06.2013	CDAB	B	93	2.0 TDI 4x4	05.2011 → 02.2013	CFHF	D	75
1.9 TDI	06.2004 → 12.2010	BJB	D	50	2.0 TDI RS	04.2006 → 02.2013	BMN	D	79
1.9 TDI	06.2004 → 12.2010	BKC	D	46	2.0 TDI RS	04.2006 → 02.2013	CEGA	D	75
1.9 TDI	06.2004 → 12.2010	BLS	D	51	<b>OCTAVIA III (5E3, NL3, NR3)</b>				
1.9 TDI	06.2004 → 12.2010	BXE	D	52	1.0 TSI	05.2016 →	CHZD	B	14
2.0 FSI	11.2004 → 10.2008	BLR	B	88	1.0 TSI	05.2016 →	DKRF	B	15
2.0 FSI	11.2004 → 10.2008	BLY	B	88	1.2 TSI	11.2012 →	CJZA	B	2
2.0 FSI	11.2004 → 10.2008	BVY	B	88	1.2 TSI	11.2012 →	CJZB	B	3
2.0 FSI	11.2004 → 10.2008	BVZ	B	88	1.2 TSI	11.2012 →	CYVA	B	4
2.0 RS	10.2005 → 02.2013	BWA	B	89	1.2 TSI	05.2015 → 02.2017	CYVB	B	7
2.0 RS	10.2005 → 02.2013	CCZA	B	90	1.4 TSI	11.2012 →	CHPA	B	11
2.0 TDI	02.2004 → 05.2010	AZV	D	74	1.4 TSI	08.2014 →	CHPB	B	11
2.0 TDI	11.2005 → 05.2010	BMM	D	77	1.4 TSI	08.2014 →	CZDA	B	12
2.0 TDI	03.2010 → 06.2013	CFHF	D	75	1.4 TSI G-TEC	11.2013 →	CPWA	BG	8
2.0 TDI	03.2010 → 06.2013	CLCA	D	75	1.6	01.2014 →	CWVA	B	37
2.0 TDI 16V	02.2004 → 04.2013	BKD	D	74	1.6 TDI	11.2012 →	CLHA	D	59
2.0 TDI 16V	02.2004 → 04.2013	CFHC	D	75	1.6 TDI	11.2012 →	CLHB	D	59
2.0 TDI 16V	02.2004 → 04.2013	CLCB	D	75	1.6 TDI	11.2012 →	CXXA	D	60
2.0 TDI RS	04.2006 → 02.2013	BMN	D	79	1.6 TDI	11.2012 →	DDYB	D	61
2.0 TDI RS	04.2006 → 02.2013	CEGA	D	75	1.6 TDI	05.2013 →	CRKB	D	59
<b>OCTAVIA II Combi (1Z5)</b>					1.6 TDI	05.2013 →	CXXB	D	60
1.2 TSI	02.2010 → 04.2013	CBZB	B	1	1.6 TDI	05.2013 →	DBKA	D	62
1.4	05.2004 → 05.2006	BCA	B	22	1.6 TDI	02.2017 →	DDYA	D	61
1.4	05.2006 → 06.2013	BUD	B	22	1.6 TDI	02.2017 →	DGTE	D	61
1.4	05.2006 → 06.2013	CGGA	B	27	1.6 TDI 4x4	09.2014 →	CLHA	D	59
1.4 TSI	11.2008 → 06.2013	CAXA	B	32	1.6 TDI 4x4	05.2015 →	CRKB	D	59
1.6	09.2004 → 06.2013	BGU	B	72	1.6 TDI 4x4	05.2015 →	CXXB	D	60
1.6	09.2004 → 06.2013	BSE	B	73	1.6 TDI 4x4	02.2017 →	DGTE	D	61
1.6	09.2004 → 06.2013	BSF	B	73	1.8 TSI	11.2012 →	CJSA	B	95
1.6	09.2004 → 06.2013	CCSA	B	73	1.8 TSI 4x4	09.2014 →	CJSB	B	95
1.6	09.2004 → 06.2013	CMXA	B	70	2.0 TDI	11.2012 →	CKFB	D	81
1.6 FSI	02.2004 → 10.2008	BLF	B	26	2.0 TDI	11.2012 →	CKFC	D	81
1.6 LPG	08.2009 → 11.2012	CHGA	BG	63	2.0 TDI	11.2012 →	CRMB	D	81
1.6 MultiFuel	01.2008 → 06.2013	CCSA	B	73	2.0 TDI	11.2012 →	CRVC	D	81
1.6 MultiFuel	01.2008 → 06.2013	CMXA	B	70	2.0 TDI	11.2012 →	CYKA	D	82
1.6 TDI	06.2009 → 04.2013	CAYC	D	57	2.0 TDI	11.2012 →	DCYA	D	82
1.6 TDI 4x4	06.2009 → 02.2013	CAYC	D	57	2.0 TDI / TDI RS 4x4	05.2013 →	CUNA	D	81
1.8 TSI	06.2007 → 04.2013	BZB	B	91	2.0 TDI / TDI RS 4x4	05.2013 →	CUPA	D	81
1.8 TSI	06.2007 → 04.2013	CDAA	B	92	2.0 TDI / TDI RS 4x4	05.2013 →	DJGA	D	83
1.8 TSI	03.2009 → 06.2013	CDAB	B	93	2.0 TDI 4x4	09.2014 →	CKFC	D	81
1.8 TSI 4x4	11.2008 → 02.2013	CDAA	B	92	2.0 TDI 4x4	09.2014 →	CRMB	D	81
1.8 TSI 4x4	03.2009 → 02.2013	CDAB	B	93	2.0 TDI 4x4	09.2014 →	DCYA	D	82
1.9 TDI	09.2004 → 12.2010	BJB	D	50	2.0 TDI RS	05.2013 →	CUNA	D	81
1.9 TDI	09.2004 → 12.2010	BKC	D	46	2.0 TDI RS	05.2013 →	CUPA	D	81
1.9 TDI	09.2004 → 12.2010	BLS	D	51	2.0 TDI RS	05.2013 →	DJGA	D	83



			Pos				Pos
2.0 TSI	02.2017 →	DKZA	B 100	1.6	10.2011 →	CLSA	B 30
2.0 TSI 4x4	02.2019 →	DKZA	B 100	1.6 TDI	10.2011 → 12.2013	CLNA	D 57
2.0 TSI RS	05.2013 →	CHHB	B 94	<b>RAPID (NH3)</b>			
2.0 TSI RS	05.2015 →	CHHA	B 99	1.0 TSI	06.2017 → 12.2019	CHZB	B 12
2.0 TSI RS	02.2017 →	DKTB	B 97	1.0 TSI	06.2017 → 12.2019	CHZC	B 12
2.0 TSI RS	02.2017 →	DLBA	B 98	1.2	07.2012 → 06.2015	CGPC	B 36
<b>OCTAVIA III Combi (5E5, 5E6)</b>				1.2 LPG	07.2012 → 05.2015	CBZA	B 1
1.0 TSI	05.2016 →	CHZD	B 14	1.2 LPG	07.2012 → 06.2015	CGPC	B 36
1.0 TSI	05.2016 →	DKRF	B 15	1.2 TSI	07.2012 → 05.2015	CBZA	B 1
1.2 TSI	11.2012 →	CJZA	B 2	1.2 TSI	07.2012 → 05.2015	CBZB	B 1
1.2 TSI	11.2012 →	CJZB	B 3	1.2 TSI	05.2015 → 12.2019	CJZC	B 5
1.2 TSI	11.2012 →	CYVA	B 4	1.2 TSI	05.2015 → 12.2019	CJZD	B 6
1.2 TSI	05.2015 → 02.2017	CYVB	B 7	1.4 TDI	05.2015 → 12.2019	CUSB	D 60
1.4 TSI	11.2012 →	CHPA	B 11	1.4 TSI	07.2012 → 06.2015	CAXA	B 32
1.4 TSI	08.2014 →	CHPB	B 11	1.4 TSI	05.2015 → 12.2019	CZCA	B 12
1.4 TSI	08.2014 →	CZDA	B 12	1.6	07.2012 → 06.2015	CFNA	B 30
1.4 TSI G-TEC	11.2013 →	CPWA	BG 8	1.6	05.2015 → 12.2019	CWVA	B 37
1.6	01.2014 →	CWVA	B 37	1.6 SRE	06.2015 → 12.2019	CWVB	B 37
1.6 TDI	11.2012 →	CLHA	D 59	1.6 TDI	07.2012 → 12.2019	CAYC	D 57
1.6 TDI	11.2012 →	CLHB	D 59	1.6 TDI	07.2012 → 12.2019	CLNA	D 57
1.6 TDI	11.2012 →	CXXA	D 60	1.6 TDI	08.2013 → 05.2015	CAYB	D 57
1.6 TDI	11.2012 →	DDYB	D 61	<b>RAPID Spaceback (NH1)</b>			
1.6 TDI	05.2013 →	CRKB	D 59	1.0 TSI	06.2017 → 12.2019	CHZB	B 12
1.6 TDI	05.2013 →	CXXB	D 60	1.0 TSI	06.2017 → 12.2019	CHZC	B 12
1.6 TDI	05.2013 →	DBKA	D 62	1.2	07.2012 → 06.2015	CGPC	B 36
1.6 TDI	02.2017 →	DDYA	D 61	1.2 LPG	07.2012 → 05.2015	CBZA	B 1
1.6 TDI	02.2017 →	DGTE	D 61	1.2 LPG	07.2012 → 06.2015	CGPC	B 36
1.6 TDI 4x4	11.2012 →	CLHA	D 59	1.2 TSI	07.2012 → 05.2015	CBZA	B 1
1.6 TDI 4x4	05.2015 →	CRKB	D 59	1.2 TSI	07.2012 → 05.2015	CBZB	B 1
1.6 TDI 4x4	05.2015 →	CXXB	D 60	1.2 TSI	05.2015 → 12.2019	CJZC	B 5
1.6 TDI 4x4	05.2015 →	DBKA	D 62	1.2 TSI	05.2015 → 12.2019	CJZD	B 6
1.6 TDI 4x4	02.2017 →	DGTE	D 61	1.4 TDI	05.2015 → 12.2019	CUSB	D 60
1.8 TSI	11.2012 →	CJSA	B 95	1.4 TSI	07.2012 → 06.2015	CAXA	B 32
1.8 TSI	11.2012 →	CJSB	B 95	1.4 TSI	05.2015 → 12.2019	CZCA	B 12
1.8 TSI 4x4	11.2012 →	CJSB	B 95	1.6	07.2012 → 06.2015	CFNA	B 30
2.0 TDI	11.2012 →	CKFB	D 81	1.6 SRE	05.2015 → 12.2019	CWVA	B 37
2.0 TDI	11.2012 →	CKFC	D 81	1.6 TDI	07.2012 → 12.2019	CAYC	D 57
2.0 TDI	11.2012 →	CRMB	D 81	1.6 TDI	07.2012 → 12.2019	CLNA	D 57
2.0 TDI	11.2012 →	CRVC	D 81	1.6 TDI	08.2013 → 05.2015	CAYB	D 57
2.0 TDI	11.2012 →	CYKA	D 82	<b>ROOMSTER (5J7)</b>			
2.0 TDI	11.2012 →	DCYA	D 82	1.2	05.2006 → 01.2007	BME	B 25
2.0 TDI / TDI RS 4x4	09.2014 →	CUNA	D 81	1.2	01.2007 → 05.2015	BZG	B 25
2.0 TDI / TDI RS 4x4	09.2014 →	CUPA	D 81	1.2	01.2007 → 05.2015	CGPA	B 25
2.0 TDI / TDI RS 4x4	09.2014 →	DJGA	D 83	1.2 LPG	03.2009 → 05.2015	CGPA	B 25
2.0 TDI 4x4	11.2012 →	CKFC	D 81	1.2 TDI	03.2010 → 05.2015	CFWA	D 58
2.0 TDI 4x4	11.2012 →	CRMB	D 81	1.2 TSI	03.2010 → 05.2015	CBZA	B 1
2.0 TDI 4x4	11.2012 →	DCYA	D 82	1.2 TSI	03.2010 → 05.2015	CBZB	B 1
2.0 TDI RS	05.2013 →	CUNA	D 81	1.4	09.2006 → 05.2015	BXW	B 29
2.0 TDI RS	05.2013 →	CUPA	D 81	1.4	09.2006 → 05.2015	CGGB	B 22
2.0 TDI RS	05.2013 →	DJGA	D 83	1.4 LPG	03.2010 → 05.2015	BXW	B 29
2.0 TSI	02.2017 →	DKZA	B 100	1.4 LPG	03.2010 → 05.2015	CGGB	B 22
2.0 TSI 4x4	02.2019 →	DKZA	B 100	1.4 TDI	07.2006 → 03.2010	BNM	D 54
2.0 TSI RS	11.2012 →	CHHB	B 94	1.4 TDI	09.2006 → 03.2010	BMS	D 55
2.0 TSI RS	05.2015 →	CHHA	B 99	1.4 TDI	09.2006 → 03.2010	BNV	D 54
2.0 TSI RS	02.2017 →	DKTB	B 97	1.6	09.2006 → 05.2015	BTS	B 28
2.0 TSI RS	02.2017 →	DLBA	B 98	1.6	09.2006 → 05.2015	CFNA	B 30
<b>OCTAVIA IV (NX3)</b>				1.6 LPG	06.2006 → 07.2010	BTS	B 28
1.6 SRE	07.2020 →	CWVA	B 37	1.6 TDI	03.2010 → 05.2015	CAYB	D 57
2.0 TDI	06.2020 →	CRVC	D 81	1.6 TDI	03.2010 → 05.2015	CAYC	D 57
2.0 TSI RS	03.2020 →	DLBA	B 98	1.9 TDI	03.2006 → 05.2006	AXR	D 46
<b>OCTAVIA IV Combi (NX5)</b>				1.9 TDI	09.2006 → 03.2010	BLS	D 51
1.6 SRE	06.2020 →	CWVA	B 37	1.9 TDI	09.2006 → 03.2010	BSW	D 56
2.0 TDI	06.2020 →	CRVC	D 81	<b>SCALA (NW1)</b>			
2.0 TSI RS	03.2020 →	DLBA	B 98	1.0 TGI CNG	11.2019 →	DBYA	BG 9
<b>PRAKTIK</b>				1.0 TSI	02.2019 →	DKLA	B 15
1.2 12V	08.2007 →	BZG	B 25	1.0 TSI	02.2019 →	DKRF	B 15
1.2 12V	08.2007 →	CGPA	B 25	1.6 SRE	02.2019 →	CWVA	B 37
1.4 16V	08.2007 →	BXW	B 29	<b>SUPERB I (3U4)</b>			
<b>RAPID (NA2)</b>				1.8 T	12.2001 → 03.2008	AWT	B 71

S



				Pos					Pos
1.9 TDI	12.2001 → 03.2008	AVF	D	47	2.0 TDI 4x4	03.2015 →	DFCA	D	82
1.9 TDI	12.2001 → 03.2008	AWX	D	47	2.0 TDI 4x4	03.2015 →	DFEA	D	82
1.9 TDI	08.2002 → 10.2005	AVB	D	45	2.0 TDI 4x4	03.2015 →	DFGA	D	82
1.9 TDI	10.2005 → 05.2007	BSV	D	53	2.0 TDI 4x4	03.2015 →	DFHA	D	82
1.9 TDI	01.2007 → 03.2008	BPZ	D	53	2.0 TSI	03.2015 →	CHHB	B	94
2.0	12.2001 → 03.2008	AZM	B	85	2.0 TSI	07.2019 →	DKZA	B	100
2.0 TDI	10.2005 → 03.2008	BSS	D	76	2.0 TSI 4x4	03.2015 →	CJXA	B	97
2.0 TDI	02.2006 → 03.2008	BWW	D	78	2.0 TSI 4x4	03.2015 →	DNUA	B	98
2.5 TDI	12.2001 → 08.2003	AYM	D	38	<b>SUPERB III Estate (3V5)</b>				
2.5 TDI	06.2003 → 03.2008	BDG	D	39	1.4 TSI	03.2015 →	CZCA	B	12
2.8 V6	12.2001 → 03.2008	AMX	B	87	1.4 TSI	03.2015 →	CZDA	B	12
2.8 V6	06.2002 → 03.2008	BBG	B	87	1.4 TSI	03.2015 →	CZEA	B	13
<b>SUPERB II (3T4)</b>					1.4 TSI 4x4	03.2015 →	CZEA	B	13
1.4 TSI	07.2008 → 05.2015	CAXC	B	32	1.8 TSI	03.2015 →	CJSA	B	95
1.6 TDI	09.2010 → 05.2015	CAYC	D	57	1.8 TSI	03.2015 →	CJSC	B	96
1.8 TSI	03.2008 → 05.2015	BZB	B	91	2.0 TDI	03.2015 →	CRGA	D	82
1.8 TSI	03.2008 → 05.2015	CDA A	B	92	2.0 TDI	03.2015 →	CRLB	D	82
1.8 TSI	03.2009 → 05.2015	CDAB	B	93	2.0 TDI	03.2015 →	DDAA	D	83
1.8 TSI 4x4	11.2008 → 05.2015	CDA A	B	92	2.0 TDI	03.2015 →	DFCA	D	82
1.8 TSI 4x4	03.2009 → 05.2015	CDAB	B	93	2.0 TDI	03.2015 →	DFEA	D	82
1.9 TDI	03.2008 → 11.2010	BLS	D	51	2.0 TDI	03.2015 →	DFGA	D	82
1.9 TDI	03.2008 → 11.2010	BXE	D	52	2.0 TDI	03.2015 →	DFHA	D	82
2.0 TDI	03.2008 → 05.2010	BMP	D	80	2.0 TDI 4x4	03.2015 →	CRLB	D	82
2.0 TDI	07.2008 → 05.2015	CBBB	D	75	2.0 TDI 4x4	03.2015 →	DDAA	D	83
2.0 TDI	07.2008 → 05.2015	CFGB	D	75	2.0 TDI 4x4	03.2015 →	DFCA	D	82
2.0 TDI 16V	01.2009 → 05.2015	BKD	D	74	2.0 TDI 4x4	03.2015 →	DFEA	D	82
2.0 TDI 16V	01.2009 → 05.2015	CFFB	D	75	2.0 TDI 4x4	03.2015 →	DFGA	D	82
2.0 TDI 16V	01.2009 → 05.2015	CLJA	D	75	2.0 TDI 4x4	03.2015 →	DFHA	D	82
2.0 TDI 16V 4x4	11.2010 → 05.2015	CFFB	D	75	2.0 TSI	03.2015 →	CHHB	B	94
2.0 TDI 4x4	09.2008 → 05.2015	CBBB	D	75	2.0 TSI	07.2019 →	DKZA	B	100
2.0 TDI 4x4	09.2008 → 05.2015	CFGB	D	75	2.0 TSI 4x4	03.2015 →	CJXA	B	97
2.0 TSI	05.2010 → 05.2015	CCZA	B	90	2.0 TSI 4x4	03.2015 →	DNUA	B	98
3.6 FSI 4x4	11.2008 → 05.2015	CDVA	B	102	<b>YETI (5L)</b>				
<b>SUPERB II Estate (3T5)</b>					1.2 TSI	09.2009 → 05.2015	CBZB	B	1
1.4 TSI	10.2009 → 05.2015	CAXC	B	32	1.2 TSI	05.2015 → 12.2017	CYVB	B	7
1.6 TDI	09.2010 → 05.2015	CAYC	D	57	1.4 TSI	06.2010 → 05.2015	CAXA	B	32
1.8 TSI	10.2009 → 05.2015	CDA A	B	92	1.4 TSI	05.2015 → 12.2017	CZCA	B	12
1.8 TSI	10.2009 → 05.2015	CDAB	B	93	1.4 TSI 4x4	05.2015 → 12.2017	CZDA	B	12
1.8 TSI 4x4	10.2009 → 05.2015	CDA A	B	92	1.6	04.2014 → 12.2017	CWVA	B	37
1.8 TSI 4x4	10.2009 → 05.2015	CDAB	B	93	1.6 TDI	11.2010 → 05.2015	CAYC	D	57
1.9 TDI	10.2009 → 11.2010	BLS	D	51	1.8 TSI 4x4	05.2009 → 12.2017	CDA A	B	92
1.9 TDI	10.2009 → 11.2010	BXE	D	52	1.8 TSI 4x4	11.2009 → 12.2017	CDAB	B	93
2.0 TDI	10.2009 → 03.2010	BMP	D	80	2.0 TDI	11.2009 → 12.2017	CFHA	D	81
2.0 TDI	10.2009 → 05.2015	CBBB	D	75	2.0 TDI	11.2009 → 12.2017	CLCA	D	75
2.0 TDI	10.2009 → 05.2015	CFGB	D	75	2.0 TDI	11.2009 → 12.2017	CUUA	D	82
2.0 TDI 16V	10.2009 → 05.2015	BKD	D	74	2.0 TDI	11.2009 → 12.2017	DFSA	D	82
2.0 TDI 16V	10.2009 → 05.2015	CFFB	D	75	2.0 TDI	11.2011 → 12.2017	CFHC	D	75
2.0 TDI 16V	10.2009 → 05.2015	CLJA	D	75	2.0 TDI	11.2011 → 12.2017	CLCB	D	75
2.0 TDI 16V 4x4	11.2010 → 05.2015	CFFB	D	75	2.0 TDI	05.2015 → 12.2017	CUUB	D	82
2.0 TDI 4x4	10.2009 → 05.2015	CBBB	D	75	2.0 TDI	05.2015 → 12.2017	DFSB	D	82
2.0 TDI 4x4	10.2009 → 05.2015	CFGB	D	75	2.0 TDI 4x4	05.2009 → 12.2017	CBDB	D	75
2.0 TSI	05.2010 → 05.2015	CCZA	B	90	2.0 TDI 4x4	05.2009 → 12.2017	CFHC	D	75
3.6 V6 4x4	10.2009 → 05.2015	CDVA	B	102	2.0 TDI 4x4	05.2009 → 12.2017	CLCB	D	75
<b>SUPERB III (3V3)</b>					2.0 TDI 4x4	11.2009 → 05.2015	CEGA	D	75
1.4 TSI	03.2015 →	CZCA	B	12	2.0 TDI 4x4	11.2009 → 05.2015	CFJA	D	75
1.4 TSI	03.2015 →	CZDA	B	12	2.0 TDI 4x4	11.2009 → 12.2017	CFHF	D	75
1.4 TSI	03.2015 →	CZEA	B	13	2.0 TDI 4x4	11.2009 → 12.2017	CUUA	D	82
1.4 TSI 4x4	03.2015 →	CZEA	B	13	2.0 TDI 4x4	11.2009 → 12.2017	DFSA	D	82
1.8 TSI	03.2015 →	CJSA	B	95	2.0 TDI 4x4	05.2015 → 12.2017	CUUB	D	82
1.8 TSI	03.2015 →	CJSC	B	96	2.0 TDI 4x4	05.2015 → 12.2017	DFSB	D	82
2.0 TDI	03.2015 →	CRGA	D	82					
2.0 TDI	03.2015 →	CRLB	D	82	<b>FABIA I Praktik (6Y5)</b>				
2.0 TDI	03.2015 →	DDAA	D	83	1.2	07.2001 → 12.2007	AWY	B	23
2.0 TDI	03.2015 →	DFCA	D	82	1.2	07.2001 → 12.2007	BMD	B	24
2.0 TDI	03.2015 →	DFEA	D	82	1.2	01.2003 → 12.2007	BME	B	25
2.0 TDI	03.2015 →	DFGA	D	82	1.2	05.2003 → 12.2007	AZQ	B	25
2.0 TDI	03.2015 →	DFHA	D	82	1.4	04.2000 → 03.2003	AZE	B	17
2.0 TDI 4x4	03.2015 →	CRLB	D	82	1.4	04.2000 → 03.2003	AZF	B	17
2.0 TDI 4x4	03.2015 →	DDAA	D	83					

S

				Pos					Pos
1.4	07.2001 → 05.2003	AME	B	17					
1.4	07.2001 → 05.2003	AQW	B	17					
1.4	07.2001 → 05.2003	ATZ	B	17					
1.4	05.2004 → 12.2007	BKY	B	20					
1.4 TDI	08.2004 → 10.2005	AMF	D	48					
1.4 TDI	10.2005 → 12.2007	BNM	D	54					
1.9 SDI	05.2003 → 12.2007	ASY	D	44					
1.9 TDI	01.2000 → 12.2007	ATD	D	45					
1.9 TDI	01.2000 → 12.2007	AXR	D	46					
<b>FELICIA Cube Van (6U5)</b>									
1.6	06.1998 → 12.2001	AEE	B	18					
1.9 D	03.1997 → 12.2001	AEF	D	40					
<b>OCTAVIA I Estate Van (1U5)</b>									
1.9 D	08.2000 → 12.2003	AQM	D	44					
1.9 TDI	08.2000 → 03.2010	ALH	D	42					
<b>ROOMSTER Praktik (5J)</b>									
1.2	03.2007 → 05.2015	BZG	B	25					
1.2	03.2007 → 05.2015	CGPA	B	25					
1.2 TDI	03.2010 → 05.2015	CFWA	D	58					
1.2 TSI	03.2010 → 05.2015	CBZA	B	1					
1.4	03.2007 → 05.2015	BXW	B	29					
1.4	03.2007 → 05.2015	CGGB	B	22					
1.4 TDI	03.2007 → 03.2010	BMS	D	55					
1.4 TDI	03.2007 → 03.2010	BNM	D	54					
1.4 TDI	03.2007 → 03.2010	BNV	D	54					
1.6 TDI	03.2010 → 05.2015	CAYB	D	57					



					Reference	Item No.	
<b>1</b>		<b>71</b>					
<b>CBZA</b>	03.2010 →	B (A)	4	1197 cm <sup>3</sup>	2V	63 kW (86 PS) 10	75,60 mm
<b>CBZB Euro 5</b>	09.2009 →	B (A)	4	1197 cm <sup>3</sup>	2V	77 kW (105 PS) 10	75,60 mm
41 257 6..							
	IN [2] EX [2] EX [2]	35,5 x 6 x 98,7 30,0 x 6 x 98,4 30,0 x 6 x 98,4	S - - RA/S- Cr - RA/S- Cr - Na	- 45° - - - 45° - VS - - 45° - VS -	22 - III 22 - III 22 - III	03F 109 601A  03F 109 611B 03F 109 611C	<b>331153</b> <b>331161</b> (1) <b>331155</b> (2)
	(1)	IAM specification					
	(2)	OES specification					
	IN/EX [4] IN/EX [4] IN/EX [4] EX [4]	11,04 x 6 x 39,0 11,05 x 6 x 36,0 11,15 x 6 x 36,0 11,04 x 6 x 39,0	B1 B1 B1 G2			058 103 415	<b>81-33121</b> <b>81-33111</b> <b>81-33118</b> <b>81-33122</b>
						03F 109 101 D	<b>50 007 677</b> (3)
	(3)	Schalenhartguss/chilled cast iron/pièce moulée trempée en surface/fundición en coquilla/Отливка с отбеленным поверхностным слоем					
	[8]	H 12 x 34,8 x 34,8				030 109 423 030 109 423 A 030 109 423 B 036 109 423 A 036 109 423 D CP40239	<b>50 006 415</b>
	[8]					03F109411	<b>50 007 642</b>
<b>2</b>		<b>71</b>					
<b>CJZA Euro 6</b>	11.2012 →	B (LA)	4	1197 cm <sup>3</sup>	4V	77 kW (105 PS) 10,5	75,60 mm
	IN [2] EX [2]	26,5 x 5 x 110,2 23,5 x 5 x 110,1	S - - RA/S- Cr -	- 45° - - - 30° - VS -	22 - III 22 - III	04E 109 601A 04E 109 611K	<b>331156</b> <b>331157</b>
	[50]	∅ 5 mm					<b>MK-5H</b>
	IN/EX [4] IN/EX [4] IN [1] EX [1]	11,04 x 6 x 39,0 11,15 x 6 x 36,0 10,06 x 5 x 45,0 10,05 x 5 x 45,0	B1 B1 B1 G2				<b>81-33121</b> <b>81-33118</b> <b>81-33123</b> <b>81-33124</b>
	[8]	H 12				04E109423C	<b>50 007 667</b>
<b>3</b>		<b>71</b>					
<b>CJZB Euro 5</b>	11.2012 →	B (LA)	4	1197 cm <sup>3</sup>	4V	63 kW (86 PS) 10,5	75,60 mm
	IN [2] EX [2]	26,5 x 5 x 110,2 23,5 x 5 x 110,1	S - - RA/S- Cr -	- 45° - - - 30° - VS -	22 - III 22 - III	04E 109 601A 04E 109 611K	<b>331156</b> <b>331157</b>
	[50]	∅ 5 mm					<b>MK-5H</b>
	IN/EX [4] IN/EX [4] IN [1] EX [4] EX [1]	11,04 x 6 x 39,0 11,15 x 6 x 36,0 10,06 x 5 x 45,0 11,04 x 6 x 39,0 10,05 x 5 x 45,0	B1 B1 B1 G2 G2				<b>81-33121</b> <b>81-33118</b> <b>81-33123</b> <b>81-33122</b> <b>81-33124</b>
Fortsetzung nächste Seite / continued on next page / suite page suivante / continuación página próxima / Продолжение на следующей странице							

S

					Reference	Item No.
[8]	H 12				04E109423C	50 007 667
[4]					04E109411AA 04E109411J	50 007 668
<b>4</b>	<b>71</b>					
<b>CYVA Euro 6</b>	11.2012 →	B (LA)	4	1197 cm <sup>3</sup> 4V	63 kW (86 PS) 10,5	75,60 mm
IN [2] EX [2]	26,5 x 5 x 110,2 23,5 x 5 x 110,1	S - - RA/S- Cr -	- 45° - - - 30° - VS -	22 - III 22 - III	04E 109 601A 04E 109 611K	<b>331156</b> <b>331157</b>
[50]	∅ 5 mm					<b>MK-5H</b>
[4]					04E109411AA 04E109411J	50 007 668
<b>5</b>	<b>71</b>					
<b>CJZC Euro 6</b>	08.2014 →	B (A)	4	1197 cm <sup>3</sup> 4V	66 kW (90 PS) 10,5	75,60 mm
IN [2] EX [2]	26,5 x 5 x 110,2 23,5 x 5 x 110,1	S - - RA/S- Cr -	- 45° - - - 30° - VS -	22 - III 22 - III	04E 109 601A 04E 109 611K	<b>331156</b> <b>331157</b>
[50]	∅ 5 mm					<b>MK-5H</b>
[8]	H 12				04E109423C	50 007 667
[4]					04E109411AA 04E109411J	50 007 668
<b>6</b>	<b>71</b>					
<b>CJZD Euro 6</b>	08.2014 →	B (LA)	4	1197 cm <sup>3</sup> 4V	81 kW (110 PS) 10,5	75,60 mm
IN [2] EX [2]	26,5 x 5 x 110,2 23,5 x 5 x 110,1	S - - RA/S- Cr -	- 45° - - - 30° - VS -	22 - III 22 - III	04E 109 601A 04E 109 611K	<b>331156</b> <b>331157</b>
[50]	∅ 5 mm					<b>MK-5H</b>
IN/EX [4] IN/EX [4]	11,04 x 6 x 39,0 11,15 x 6 x 36,0	B1 B1				<b>81-33121</b> <b>81-33118</b>
<b>7</b>	<b>71</b>					
<b>CYVB</b>	05.2015 → 12.2017	B (LA)	4	1197 cm <sup>3</sup> 4V	81 kW (110 PS) 10,5	75,60 mm
IN [2] EX [2]	26,5 x 5 x 110,2 23,5 x 5 x 110,1	S - - RA/S- Cr -	- 45° - - - 30° - VS -	22 - III 22 - III	04E 109 601A 04E 109 611K	<b>331156</b> <b>331157</b>
[50]	∅ 5 mm					<b>MK-5H</b>
IN [1] EX [1]	10,06 x 5 x 45,0 10,05 x 5 x 45,0	B1 G2				<b>81-33123</b> <b>81-33124</b>
[4]					04E109411AA 04E109411J	50 007 668
<b>8</b>	<b>74,5</b>					
<b>CPWA</b>	11.2013 →	BG (A)	4	1395 cm <sup>3</sup> 4V	81 kW (110 PS) 10,5	80,00 mm
Fortsetzung nächste Seite / continued on next page / suite page suivante / continuación página próxima / Продолжение на следующей странице						

					Reference	Item No.
IN [2] EX [2]	28,5 x 5 x 110,2 25,0 x 5 x 110,1	S - Ni - RA/S- Ni -	- 45° - VS - - 30° - VS -	22 - III 22 - III	04E 109 601 P 04C 109 611C 04E 109 611AC 04E 109 611AJ	<b>331163</b> <small>NEW</small> <b>331164</b> <small>NEW</small>
[50]	Ø 5 mm					<b>MK-5H</b>
[4]					04E109411AA 04E109411J	<b>50 007 668</b>
<b>9</b>	<b>74,5</b>					
<b>DBYA</b>	11.2019 →	BG (A)	3	999 cm <sup>3</sup> 4V	66 kW (90 PS)	76,40 mm
IN [2] EX [2]	28,5 x 5 x 110,2 25,0 x 5 x 110,1	S - - RA/S- Ni -	- 45° - - - 30° - VS -	22 - III 22 - III	04E 109 601B 04C 109 611C 04E 109 611AC 04E 109 611AJ	<b>331158</b> <small>NEW</small> <b>331164</b> <small>NEW</small>
[50]	Ø 5 mm					<b>MK-5H</b>
<b>10</b>	<b>74,5</b>					
<b>CHYA Filter</b>	10.2011 →	B (NA)	3	999 cm <sup>3</sup> 4V	44 kW (60 PS)	76,40 mm
<b>CHYB Filter</b>	10.2011 →	B (NA)	3	999 cm <sup>3</sup> 4V	55 kW (75 PS)	10,5 76,40 mm
41 272 6..						
IN [2] EX [2]	29,6 x 5 x 110,2 27,0 x 5 x 110,1	S - - A/S - Cr -	- 45° - - - 30° - VS -	22 - III 22 - III	04C 109 601C 04E 109 601 04C 109 611A 04E 109 611L	<b>398000</b> <small>NEW</small> <b>398001</b> <small>NEW</small>
[50]	Ø 5 mm					<b>MK-5H</b>
IN [1] EX [1]	10,06 x 5 x 45,0 10,05 x 5 x 45,0	B1 G2				<b>81-33123</b> <small>NEW</small> <b>81-33124</b> <small>NEW</small>
[8]	H 12				04E109423C	<b>50 007 667</b>
[4]					04E109411AA 04E109411J	<b>50 007 668</b>
<b>11</b>	<b>74,5</b>					
<b>CHPA Euro 5</b>	11.2012 →	B (LA)	4	1395 cm <sup>3</sup> 4V	103 kW (140 PS)	10,5 80,00 mm
<b>CHPB Euro 6</b>	08.2014 →	B (LA)	4	1395 cm <sup>3</sup> 4V	110 kW (150 PS)	10 80,00 mm
IN [2] EX [2]	28,5 x 5 x 110,2 25,0 x 5 x 110,1	S - - RA/S- Cr -	- 45° - - - 30° - VS -	22 - III 22 - III	04E 109 601B 04E 109 611H 04E 109 611J	<b>331158</b> <small>NEW</small> <b>331159</b> <small>NEW</small>
[50]	Ø 5 mm					<b>MK-5H</b>
[8]	H 12				04E109423C	<b>50 007 667</b>
[4]					04E109411AA 04E109411J	<b>50 007 668</b>
<b>12</b>	<b>74,5</b>					
<b>CHZB Euro 6</b>	08.2014 →	B (A)	3	999 cm <sup>3</sup> 4V	70 kW (95 PS)	10,5 76,40 mm
<b>CHZC Euro 6</b>	08.2014 →	B (A)	3	999 cm <sup>3</sup> 4V	81 kW (110 PS)	10,5 76,40 mm
<b>CZCA Euro 6</b>	03.2015 →	B (LA)	4	1395 cm <sup>3</sup> 4V	92 kW (125 PS)	10 80,00 mm
<b>CZDA Euro 6</b>	08.2014 →	B (LA)	4	1395 cm <sup>3</sup> 4V	110 kW (150 PS)	10 80,00 mm

Fortsetzung nächste Seite / continued on next page / suite page suivante / continuación página próxima / Продолжение на следующей странице

					Reference	Item No.
IN [2] EX [2]	28,5 x 5 x 110,2 25,0 x 5 x 110,1	S - - RA/S- Cr -	- 45° - - - 30° - VS -	22 - III 22 - III	04E 109 601B 04E 109 611H 04E 109 611J	<b>331158</b> <b>331159</b>
[50]	Ø 5 mm					<b>MK-5H</b>
<b>13</b>	<b>74,5</b>					
<b>CZEA Euro 6</b>	03.2015 →	B (LA) 4	1395 cm <sup>3</sup> 4V	110 kW	(150 PS) 10	80,00 mm
<b>DAFA</b>		B (NA) 3	999 cm <sup>3</sup> 4V	44 kW	(60 PS)	76,40 mm
41 272 6..						
IN [2] EX [2]	29,6 x 5 x 110,2 27,0 x 5 x 110,1	S - - A/S - Cr -	- 45° - - - 30° - VS -	22 - III 22 - III	04C 109 601C 04E 109 601 04C 109 611A 04E 109 611L	<b>398000</b> <b>398001</b>
[50]	Ø 5 mm					<b>MK-5H</b>
IN [1] EX [1]	10,06 x 5 x 45,0 10,05 x 5 x 45,0	B1 G2				<b>81-33123</b> <b>81-33124</b>
<b>14</b>	<b>74,5</b>					
<b>CHZD</b>	05.2016 →	B (LA) 3	999 cm <sup>3</sup> 4V	85 kW	(115 PS) 10,5	76,40 mm
IN [2] EX [2]	28,5 x 5 x 110,2 25,0 x 5 x 110,1	S - - RA/S- Ni -	- 45° - - - 30° - VS -	22 - III 22 - III	04E 109 601B 04C 109 611C 04E 109 611AC 04E 109 611AJ	<b>331158</b> <b>331164</b>
[50]	Ø 5 mm					<b>MK-5H</b>
IN [1] EX [1]	10,06 x 5 x 45,0 10,05 x 5 x 45,0	B1 G2				<b>81-33123</b> <b>81-33124</b>
<b>15</b>	<b>74,5</b>					
<b>CHZJ</b>	07.2017 →	B (A) 3	999 cm <sup>3</sup> 4V	85 kW	(115 PS)	76,40 mm
<b>DKLA</b>	02.2019 →	B (A) 3	999 cm <sup>3</sup> 4V	70 kW	(95 PS)	76,40 mm
<b>DKRF Euro 6</b>	05.2016 →	B (LA) 3	999 cm <sup>3</sup> 4V	85 kW	(115 PS)	76,40 mm
IN [2] EX [2]	28,5 x 5 x 110,2 25,0 x 5 x 110,1	S - - RA/S- Ni -	- 45° - - - 30° - VS -	22 - III 22 - III	04E 109 601B 04C 109 611C 04E 109 611AC 04E 109 611AJ	<b>331158</b> <b>331164</b>
[50]	Ø 5 mm					<b>MK-5H</b>
<b>16</b>	<b>74,51</b>					
<b>CPGA Euro 5</b>	11.2012 → 08.2019	BG (NA) 3	999 cm <sup>3</sup> 4V	50 kW	(68 PS) 11,5	76,40 mm
IN [2] EX [2]	29,6 x 5 x 110,2 27,0 x 5 x 110,1	S - - A/S - Cr -	- 45° - - - 30° - VS -	22 - III 22 - III	04C 109 601C 04E 109 601 04C 109 611A 04E 109 611L	<b>398000</b> <b>398001</b>
[50]	Ø 5 mm					<b>MK-5H</b>
IN [1] EX [1]	10,06 x 5 x 45,0 10,05 x 5 x 45,0	B1 G2				<b>81-33123</b> <b>81-33124</b>
[8]	H 12				04E109423C	<b>50 007 667</b>
Fortsetzung nächste Seite / continued on next page / suite page suivante / continuación página próxima / Продолжение на следующей странице						

					Reference	Item No.	
[4]					04E109411AA 04E109411J	<b>50 007 668</b>	
<b>17</b>	<b>75,5</b>						
<b>AMD</b>	04.1999 → 03.2001	B (NA)	4	1397 cm <sup>3</sup>	2V 44 kW (60 PS)	10:1 78,00 mm	
<b>AME</b>	08.1999 → 05.2003	B (NA)	4	1397 cm <sup>3</sup>	2V 50 kW (68 PS)	10:1 78,00 mm	
<b>AQW</b>	08.1999 → 05.2003	B (NA)	4	1397 cm <sup>3</sup>	2V 50 kW (68 PS)	10:1 78,00 mm	
<b>ATZ</b>	08.1999 → 05.2003	B (NA)	4	1397 cm <sup>3</sup>	2V 50 kW (68 PS)	10 78,00 mm	
<b>AZE</b>	04.2000 → 03.2003	B (NA)	4	1397 cm <sup>3</sup>	2V 44 kW (60 PS)	10 78,00 mm	
<b>AZF</b>	04.2000 → 03.2003	B (NA)	4	1397 cm <sup>3</sup>	2V 44 kW (60 PS)	10:1 78,00 mm	
94 865 6..							
[50]	∅ 7 mm				021 109 651	<b>MK-7H</b>	
<b>18</b>	<b>76,5</b>						
<b>AEE</b>	08.1995 → 09.2004	B (NA)	4	1598 cm <sup>3</sup>	2V 55 kW (75 PS)	9,8 86,90 mm	
IN [2]	35,5 x 7 x 94,7	S - -		- 45° - -	22 - III	030 109 601 AH 030109601AH	<b>39530</b>
EX [2]	29,0 x 7 x 95,0	RA/S- -		- 45° - VS -	22 - III	032 109 611 G 032109611G	<b>39467</b>
[50]	∅ 7 mm					021 109 651	<b>MK-7H</b>
IN/EX [4]	11,08/15 x 7 x 33,0	B1				032 103 419 A	<b>81-33109</b>
IN/EX [4]	11,28/15 x 7 x 33,0	B1					<b>81-33110</b>
						032 109 101 S	<b>50 006 382</b> (1)
(1) Schalenhartguss/chilled cast iron/pièce moulée trempée en surface/fundición en coquilla/Отливка с отбеленным поверхностным слоем							
[8]	H 35 x 26 x 26					050 109 309 050 109 309 A 050 109 309 H 050 109 309 J	<b>50 006 417</b>
<b>19</b>	<b>76,5</b>						
<b>AUA</b>	10.1999 → 03.2008	B (NA)	4	1390 cm <sup>3</sup>	4V 55 kW (75 PS)	10,5 75,60 mm	
<b>BBY</b>	10.1999 → 03.2008	B (NA)	4	1390 cm <sup>3</sup>	4V 55 kW (75 PS)	10,5 75,60 mm	
99 562 6..							
IN [2]	29,5 x 6 x 100,9	S - -		- 45° - -	22 - III	036 109 601 AD 036 109 601 AK 036 109 601 AL 036 109 601 S 036109601S 03C 109 601 J 03C 109 601 M	<b>39522</b>
EX [2]	26,0 x 6 x 100,6	RA/S- -		- 45° - VS -	22 - III	036 109 611 AE 036 109 611 K 03C 109 611 G 03C 109 611 R 03C 109 612	<b>39523</b>
[50]	∅ 6 mm					036 109 651A	<b>MK-6H</b>
IN/EX [4]	11,04 x 6 x 39,0	B1					<b>81-33121</b>
IN/EX [4]	11,05 x 6 x 36,0	B1				058 103 415	<b>81-33111</b>
IN/EX [4]	11,15 x 6 x 36,0	B1					<b>81-33118</b>
EX [4]	11,04 x 6 x 39,0	G2					<b>81-33122</b>
Fortsetzung nächste Seite / continued on next page / suite page suivante / continuación página próxima / Продолжение на следующей странице							

**S**

					Reference	Item No.
	AS ES				036 109 101 AA 036 109 101 AC 036 109 101 DG	<b>50 006 155</b> (1) <b>50 006 156</b> (1)
(1)	Schalenhartguss/chilled cast iron/pièce moulée trempée en surface/fundición en coquilla/Отливка с отбеленным поверхностным слоем					
[8]	H 12 x 34,8 x 34,8				030 109 423 030 109 423 A 030 109 423 B 036 109 423 A 036 109 423 D CP40239	<b>50 006 415</b>
[4]					036 109 411 036 109 411 C 036 109 411 D	<b>50 006 142</b>

## 20 76,5

BKY 10.1999 → 03.2008 B (NA) 4 1390 cm<sup>3</sup> 4V 55 kW (75 PS) 10,5 75,60 mm  
99 913 6..

IN [2]	29,5 x 6 x 100,9	S - -	- 45° - -	22 - III	036 109 601 AD 036 109 601 AK 036 109 601 AL 036 109 601 S 036109601S 03C 109 601 J 03C 109 601 M	<b>39522</b>
EX [2]	26,0 x 6 x 100,6	RA/S- -	- 45° - VS -	22 - III	036 109 611 AE 036 109 611 K 03C 109 611 G 03C 109 611 R 03C 109 612	<b>39523</b>
[50]	∅ 6 mm				036 109 651A	<b>MK-6H</b>
IN/EX [4]	11,04 x 6 x 39,0	B1			058 103 415	<b>81-33121</b>
IN/EX [4]	11,05 x 6 x 36,0	B1				<b>81-33111</b>
IN/EX [4]	11,15 x 6 x 36,0	B1				<b>81-33118</b>
EX [4]	11,04 x 6 x 39,0	G2				<b>81-33122</b>
	AS				036 109 101 AA	<b>50 006 155</b> (1)
(1)	Schalenhartguss/chilled cast iron/pièce moulée trempée en surface/fundición en coquilla/Отливка с отбеленным поверхностным слоем					
[8]	H 12 x 34,8 x 34,8				030 109 423 030 109 423 A 030 109 423 B 036 109 423 A 036 109 423 D CP40239	<b>50 006 415</b>
[4]					036 109 411 036 109 411 C 036 109 411 D	<b>50 006 142</b>

## 21 76,5

AUB 12.1999 → 03.2008 B (NA) 4 1390 cm<sup>3</sup> 4V 74 kW (100 PS) 10,5 75,60 mm  
BBZ 12.1999 → 03.2008 B (NA) 4 1390 cm<sup>3</sup> 4V 74 kW (100 PS) 10,5 75,60 mm  
99 562 6..

Fortsetzung nächste Seite / continued on next page / suite page suivante / continuación página próxima / Продолжение на следующей странице



						Reference	Item No.
	IN [2] 29,5 x 6 x 100,9	S - -	- 45° - -	22 - III	036 109 601 AD 036 109 601 AK 036 109 601 AL 036 109 601 S 036109601S 03C 109 601 J 03C 109 601 M	<b>39522</b>	
	EX [2] 26,0 x 6 x 100,6	RA/S- -	- 45° - VS -	22 - III	036 109 611 AE 036 109 611 K 03C 109 611 G 03C 109 611 R 03C 109 612	<b>39523</b>	
	[50] Ø 6 mm				036 109 651A	<b>MK-6H</b>	
	IN/EX [4] 11,04 x 6 x 39,0 IN/EX [4] 11,05 x 6 x 36,0 IN/EX [4] 11,15 x 6 x 36,0 EX [4] 11,04 x 6 x 39,0	B1 B1 B1 G2			058 103 415	<b>81-33121</b> <small>NEW</small> <b>81-33111</b> <b>81-33118</b> <small>NEW</small> <b>81-33122</b> <small>NEW</small>	
	ES AS				036 109 101DH 036 109 101AG	<b>50 007 636</b> <b>50 007 637</b>	
	[8] H 12 x 34,8 x 34,8				030 109 423 030 109 423 A 030 109 423 B 036 109 423 A 036 109 423 D CP40239	<b>50 006 415</b>	
	[4]				036 109 411 036 109 411 C 036 109 411 D	<b>50 006 142</b>	

## 22 76,5

<b>AXP</b>	08.2000 → 12.2010	B (NA)	4	1390 cm <sup>3</sup>	4V	55 kW	(75 PS)	10,5	75,60 mm
<b>BCA</b>	08.2000 → 12.2010	B (NA)	4	1390 cm <sup>3</sup>	4V	55 kW	(75 PS)	10,5	75,60 mm
<b>BUD</b>	06.2004 → 06.2013	B (NA)	4	1390 cm <sup>3</sup>	4V	59 kW	(80 PS)	10,5	75,60 mm
<b>CGGB Euro 5</b>	09.2006 → 05.2015	B (NA)	4	1390 cm <sup>3</sup>	4V	63 kW	(85 PS)	10,5:1	75,60 mm

40 839 6.., 99 562 6.., 99 913 6..

	IN [2] 29,5 x 6 x 100,9	S - -	- 45° - -	22 - III	036 109 601 AD 036 109 601 AK 036 109 601 AL 036 109 601 S 036109601S 03C 109 601 J 03C 109 601 M	<b>39522</b>
	EX [2] 26,0 x 6 x 100,6	RA/S- -	- 45° - VS -	22 - III	036 109 611 AE 036 109 611 K 03C 109 611 G 03C 109 611 R 03C 109 612	<b>39523</b>
	[50] Ø 6 mm				036 109 651A	<b>MK-6H</b>
	IN/EX [4] 11,04 x 6 x 39,0 IN/EX [4] 11,05 x 6 x 36,0 IN/EX [4] 11,15 x 6 x 36,0 EX [4] 11,04 x 6 x 39,0	B1 B1 B1 G2			058 103 415	<b>81-33121</b> <small>NEW</small> <b>81-33111</b> <b>81-33118</b> <small>NEW</small> <b>81-33122</b> <small>NEW</small>
	AS ES				036 109 101 AA 03C 109 101 CG 03C 109 101 EC	<b>50 006 155</b> (1) <b>50 007 678</b> (1)
	(1) Schalenhartguss/chilled cast iron/pièce moulée trempée en surface/fundición en coquilla/Отливка с отбеленным поверхностным слоем					

Fortsetzung nächste Seite / continued on next page / suite page suivante / continuación página próxima / Продолжение на следующей странице

					Reference	Item No.
[8]	H 12 x 34,8 x 34,8				030 109 423 030 109 423 A 030 109 423 B 036 109 423 A 036 109 423 D CP40239	50 006 415
[4]					036 109 411 036 109 411 C 036 109 411 D	50 006 142

## 23 76,5

**AWY** 07.2001 → 12.2007 B (NA) 3 1198 cm<sup>3</sup> 2V 40 kW (54 PS) 10,3 86,90 mm  
99 452 6..

IN [2]	34,5 x 6 x 99,2	S - Cr -	- 45° - -	22 - III	032 109 601L 032 109 601M 03D 109 601B	331137
EX [2]	28,0 x 6 x 99,1	A/S - -	- 45° - VS -	22 - III	030109611T 032 109 611L 032 109 611M 03D 109 611A	331047
[50]	Ø 6 mm				036 109 651A	MK-6H
IN/EX [4]	11,04 x 6 x 39,0	B1			058 103 415	81-33121
IN/EX [4]	11,05 x 6 x 36,0	B1				81-33111
IN/EX [4]	11,15 x 6 x 36,0	B1				81-33118
IN/EX [4]	12,06 x 5.99 x 36,4	B1				81-33113
EX [4]	11,04 x 6 x 39,0	G2				81-33122
[8]	H 12 x 34,8 x 34,8				030 109 423 030 109 423 A 030 109 423 B 036 109 423 A 036 109 423 D CP40239	50 006 415
[4]					030 109 417 D	50 006 141

## 24 76,5

**BBM** 12.2006 → 12.2014 B (NA) 3 1198 cm<sup>3</sup> 2V 44 kW (60 PS) 10,5 86,90 mm  
**BMD** 07.2001 → 12.2007 B (NA) 3 1198 cm<sup>3</sup> 2V 40 kW (54 PS) 10,3 86,90 mm  
**CHFA** 12.2006 → 12.2014 B (NA) 3 1198 cm<sup>3</sup> 2V 44 kW (60 PS) 10,5 86,90 mm  
99 452 6..

IN [2]	34,5 x 6 x 99,2	S - Cr -	- 45° - -	22 - III	032 109 601L 032 109 601M 03D 109 601B	331137
EX [2]	28,0 x 6 x 99,1	A/S - -	- 45° - VS -	22 - III	030109611T 032 109 611L 032 109 611M 03D 109 611A	331047
IN/EX [4]	11,04 x 6 x 39,0	B1			058 103 415	81-33121
IN/EX [4]	11,05 x 6 x 36,0	B1				81-33111
IN/EX [4]	11,15 x 6 x 36,0	B1				81-33118
EX [4]	11,04 x 6 x 39,0	G2				81-33122
[8]	H 12 x 34,8 x 34,8				030 109 423 030 109 423 A 030 109 423 B 036 109 423 A 036 109 423 D CP40239	50 006 415

Fortsetzung nächste Seite / continued on next page / suite page suivante / continuación página próxima / Продолжение на следующей странице

					Reference	Item No.			
[4]					030 109 417 D	50 006 141			
<b>25</b>	<b>76,5</b>								
<b>AZQ</b>	01.2003 → 03.2008	B (NA)	3	1198 cm <sup>3</sup>	4V	47 kW (64 PS)	10,5	86,90 mm	
<b>BME</b>	01.2003 → 03.2008	B (NA)	3	1198 cm <sup>3</sup>	4V	47 kW (64 PS)	10,5	86,90 mm	
<b>BZG</b>	01.2007 →	B (NA)	3	1198 cm <sup>3</sup>	4V	51 kW (70 PS)	10,5	86,90 mm	
<b>CGPA</b>	01.2007 →	B (NA)	3	1198 cm <sup>3</sup>	4V	51 kW (70 PS)	10,5	86,90 mm	
<b>CGPB</b>	11.2011 → 12.2014	B (NA)	3	1198 cm <sup>3</sup>	4V	44 kW (60 PS)	10,5	86,90 mm	
40 795 6.., 99 909 6..									
IN [2]	29,5 x 6 x 100,9	S - -		- 45° -		22 - III	036 109 601 AD 036 109 601 AK 036 109 601 AL 036 109 601 S 036109601S 03C 109 601 J 03C 109 601 M	39522	
EX [2]	26,0 x 6 x 100,6	RA/S- -		- 45° -	VS -	22 - III	036 109 611 AE 036 109 611 K 03C 109 611 G 03C 109 611 R 03C 109 612	39523	
[50]	∅ 6 mm						036 109 651A	MK-6H	
IN/EX [4]	11,04 x 6 x 39,0	B1					058 103 415	81-33121	
IN/EX [4]	11,05 x 6 x 36,0	B1						81-33111	
IN/EX [4]	11,15 x 6 x 36,0	B1						81-33118	
EX [4]	11,04 x 6 x 39,0	G2						81-33122	
	ES AS						03E109101T 03E109101AA	50 007 654 50 007 655	
[8]	H 12 x 34,8 x 34,8						030 109 423 030 109 423 A 030 109 423 B 036 109 423 A 036 109 423 D CP40239	50 006 415	
[4]							036 109 411 036 109 411 C 036 109 411 D	50 006 142	
<b>26</b>	<b>76,5</b>								
<b>BLF</b>	02.2004 → 10.2008	B (NA)	4	1598 cm <sup>3</sup>	4V	85 kW (115 PS)	12	86,90 mm	
IN [2]	29,5 x 6 x 100,9	S - -		- 45° -		22 - III	036 109 601 AD 036 109 601 AK 036 109 601 AL 036 109 601 S 036109601S 03C 109 601 J 03C 109 601 M	39522	
EX [2]	26,0 x 6 x 100,6	RA/S- -		- 45° -	VS -	22 - III	036 109 611 AE 036 109 611 K 03C 109 611 G 03C 109 611 R 03C 109 612	39523	
[50]	∅ 6 mm						036 109 651A	MK-6H	
Fortsetzung nächste Seite / continued on next page / suite page suivante / continuación página próxima / Продолжение на следующей странице									

S

					Reference	Item No.
	IN/EX [4] 11,04 x 6 x 39,0 IN/EX [4] 11,05 x 6 x 36,0 IN/EX [4] 11,15 x 6 x 36,0 EX [4] 11,04 x 6 x 39,0	B1 B1 B1 G2			058 103 415	<b>81-33121</b> <b>81-33111</b> <b>81-33118</b> <b>81-33122</b>
	ES AS  (1) Schalenhartguss/chilled cast iron/pièce moulée trempée en surface/fundición en coquilla/Отливка с отбеленным поверхностным слоем				03C 109 101 AT 03C 109 101 AF	<b>50 007 034</b> (1) <b>50 007 035</b> (1)
	[8] H 12 x 34,8 x 34,8				030 109 423 030 109 423 A 030 109 423 B 036 109 423 A 036 109 423 D CP40239	<b>50 006 415</b>
	[4]				036 109 411 E 036 109 411 H	<b>50 006 143</b>
<b>27</b>	<b>76,5</b>					
<b>CGGA</b> 40 839 6..	06.2004 → 06.2013	B (NA) 4	1390 cm <sup>3</sup> 4V	59 kW	(80 PS) 10,5	75,60 mm
	IN [2] 29,5 x 6 x 100,9  EX [2] 26,0 x 6 x 100,6	S - - RA/S- -	- 45° - - - 45° - VS -	22 - III 22 - III	036 109 601 AD 036 109 601 AK 036 109 601 AL 036 109 601 S 036109601S 03C 109 601 J 03C 109 601 M 036 109 611 AE 036 109 611 K 03C 109 611 G 03C 109 611 R 03C 109 612	<b>39522</b>  <b>39523</b>
	[50] Ø 6 mm				036 109 651A	<b>MK-6H</b>
	IN/EX [4] 11,04 x 6 x 39,0 IN/EX [4] 11,05 x 6 x 36,0 IN/EX [4] 11,15 x 6 x 36,0 EX [4] 11,04 x 6 x 39,0	B1 B1 B1 G2			058 103 415	<b>81-33121</b> <b>81-33111</b> <b>81-33118</b> <b>81-33122</b>
	[8] H 12 x 34,8 x 34,8				030 109 423 030 109 423 A 030 109 423 B 036 109 423 A 036 109 423 D CP40239	<b>50 006 415</b>
	[4]				036 109 411 036 109 411 C 036 109 411 D	<b>50 006 142</b>
<b>28</b>	<b>76,5</b>					
<b>BTS</b>	06.2006 → 05.2015	B (NA) 4	1598 cm <sup>3</sup> 4V	77 kW	(105 PS) 10,5	86,90 mm
Fortsetzung nächste Seite / continued on next page / suite page suivante / continuación página próxima / Продолжение на следующей странице						

					Reference	Item No.
IN [2]	29,5 x 6 x 100,9	S - -	- 45° - -	22 - III	036 109 601 AD 036 109 601 AK 036 109 601 AL 036 109 601 S 036109601S 03C 109 601 J 03C 109 601 M	<b>39522</b>
EX [2]	26,0 x 6 x 100,6	RA/S- -	- 45° - VS -	22 - III	036 109 611 AE 036 109 611 K 03C 109 611 G 03C 109 611 R 03C 109 612	<b>39523</b>
[50]	Ø 6 mm				036 109 651A	<b>MK-6H</b>
IN/EX [4]	11,04 x 6 x 39,0	B1			058 103 415	<b>81-33121</b>
IN/EX [4]	11,05 x 6 x 36,0	B1				<b>81-33111</b>
IN/EX [4]	11,15 x 6 x 36,0	B1				<b>81-33118</b>
EX [4]	11,04 x 6 x 39,0	G2				<b>81-33122</b>
	ES AS				03C109101DE 03C 109 101 DF	<b>50 007 656</b> <b>50 007 019</b> (1)
	(1) Schalenhartguss/chilled cast iron/pièce moulée trempée en surface/fundición en coquilla/Отливка с отбеленным поверхностным слоем					
[8]	H 12 x 34,8 x 34,8				030 109 423 030 109 423 A 030 109 423 B 036 109 423 A 036 109 423 D CP40239	<b>50 006 415</b>
[4]					036 109 411 E 036 109 411 H	<b>50 006 143</b>

**29**
**76,5**
**BXW**  
40 839 6..

09.2006 →

B (NA) 4

1390 cm<sup>3</sup> 4V

63 kW

(86 PS) 10,5:1

75,60 mm

**S**

IN [2]	29,5 x 6 x 100,9	S - -	- 45° - -	22 - III	036 109 601 AD 036 109 601 AK 036 109 601 AL 036 109 601 S 036109601S 03C 109 601 J 03C 109 601 M	<b>39522</b>
EX [2]	26,0 x 6 x 100,6	RA/S- -	- 45° - VS -	22 - III	036 109 611 AE 036 109 611 K 03C 109 611 G 03C 109 611 R 03C 109 612	<b>39523</b>
[50]	Ø 6 mm				036 109 651A	<b>MK-6H</b>
IN/EX [4]	11,04 x 6 x 39,0	B1			058 103 415	<b>81-33121</b>
IN/EX [4]	11,05 x 6 x 36,0	B1				<b>81-33111</b>
IN/EX [4]	11,15 x 6 x 36,0	B1				<b>81-33118</b>
EX [4]	11,04 x 6 x 39,0	G2				<b>81-33122</b>
	ES				03C 109 101 CG 03C 109 101 EC	<b>50 007 678</b> (1)
	(1) Schalenhartguss/chilled cast iron/pièce moulée trempée en surface/fundición en coquilla/Отливка с отбеленным поверхностным слоем					

Fortsetzung nächste Seite / continued on next page / suite page suivante / continuación página próxima / Продолжение на следующей странице

					Reference	Item No.
[8]	H 12 x 34,8 x 34,8				030 109 423 030 109 423 A 030 109 423 B 036 109 423 A 036 109 423 D CP40239	50 006 415
[4]					036 109 411 036 109 411 C 036 109 411 D	50 006 142

## 30 76,5

CFNA Euro 4	09.2006 → 06.2015	B (NA)	4	1598 cm <sup>3</sup>	4V	77 kW	(105 PS)	10,5	86,90 mm
CLSA	04.2007 →	B (NA)	4	1598 cm <sup>3</sup>	4V	77 kW	(105 PS)	10,5	86,90 mm

IN [2]	29,5 x 6 x 100,9	S - -	- 45° - -	22 - III	036 109 601 AD 036 109 601 AK 036 109 601 AL 036 109 601 S 036109601S 03C 109 601 J 03C 109 601 M	39522
EX [2]	26,0 x 6 x 100,6	RA/S- -	- 45° - VS -	22 - III	036 109 611 AE 036 109 611 K 03C 109 611 G 03C 109 611 R 03C 109 612	39523
[50]	Ø 6 mm				036 109 651A	MK-6H
IN/EX [4]	11,04 x 6 x 39,0	B1			058 103 415	81-33121
IN/EX [4]	11,05 x 6 x 36,0	B1				81-33111
IN/EX [4]	11,15 x 6 x 36,0	B1				81-33118
EX [4]	11,04 x 6 x 39,0	G2				81-33122
	ES AS				03C 109 101 CP 03C 109 101 CQ	50 007 025  (1) 50 007 026  (1)
	(1) Schalenhartguss/chilled cast iron/pièce moulée trempée en surface/fundición en coquilla/Отливка с отбеленным поверхностным слоем					
[8]	H 12 x 34,8 x 34,8				030 109 423 030 109 423 A 030 109 423 B 036 109 423 A 036 109 423 D CP40239	50 006 415

## 31 76,5

CEVA	01.2007 → 12.2014	B (NA)	3	1198 cm <sup>3</sup>	4V	51 kW	(70 PS)	10,5:1	86,90 mm
CHTA	01.2007 → 12.2014	B (NA)	3	1198 cm <sup>3</sup>	4V	51 kW	(70 PS)	10,5	86,90 mm

IN [2]	29,5 x 6 x 100,9	S - -	- 45° - -	22 - III	036 109 601 AD 036 109 601 AK 036 109 601 AL 036 109 601 S 036109601S 03C 109 601 J 03C 109 601 M	39522
EX [2]	26,0 x 6 x 100,6	RA/S- -	- 45° - VS -	22 - III	036 109 611 AE 036 109 611 K 03C 109 611 G 03C 109 611 R 03C 109 612	39523
[50]	Ø 6 mm				036 109 651A	MK-6H

Fortsetzung nächste Seite / continued on next page / suite page suivante / continuación página próxima / Продолжение на следующей странице



					Reference	Item No.
	IN/EX [4] 11,04 x 6 x 39,0 IN/EX [4] 11,05 x 6 x 36,0 IN/EX [4] 11,15 x 6 x 36,0 EX [4] 11,04 x 6 x 39,0	B1 B1 B1 G2			058 103 415	<b>81-33121</b> <b>81-33111</b> <b>81-33118</b> <b>81-33122</b>

## 32 76,5

<b>CAXA Euro 5</b>	11.2008 → 06.2015	B (LA)	4	1390 cm <sup>3</sup>	4V	90 kW	(122 PS)	10	75,60 mm
<b>CAXC</b>	07.2008 → 05.2015	B (LA)	4	1390 cm <sup>3</sup>	4V	92 kW	(125 PS)	10	75,60 mm

	IN [2] 29,5 x 6 x 100,9	S - -	- 45° - -	22 - III	036 109 601 AD 036 109 601 AK 036 109 601 AL 036 109 601 S 036109601S 03C 109 601 J 03C 109 601 M	<b>39522</b>
	EX [2] 26,0 x 6 x 100,6	RA/S- -	- 45° - VS -	22 - III	036 109 611 AE 036 109 611 K 03C 109 611 G 03C 109 611 R 03C 109 612	<b>39523</b>
	[50] Ø 6 mm				036 109 651A	<b>MK-6H</b>
	IN/EX [4] 11,04 x 6 x 39,0 IN/EX [4] 11,05 x 6 x 36,0 IN/EX [4] 11,15 x 6 x 36,0 EX [4] 11,04 x 6 x 39,0	B1 B1 B1 G2			058 103 415	<b>81-33121</b> <b>81-33111</b> <b>81-33118</b> <b>81-33122</b>
	ES AS				03C 109 101 DC 03C 109 101 DD	<b>50 007 018</b> (1) <b>50 007 056</b> (1)
	(1) Schalenhartguss/chilled cast iron/pièce moulée trempée en surface/fundición en coquilla/Отливка с отбеленным поверхностным слоем					
	[8] H 12 x 34,8 x 34,8				030 109 423 030 109 423 A 030 109 423 B 036 109 423 A 036 109 423 D CP40239	<b>50 006 415</b>
	[4]				036 109 411 E 036 109 411 H	<b>50 006 143</b>

## 33 76,5

<b>CAVE</b>	05.2010 → 12.2014	B (A)	4	1390 cm <sup>3</sup>	4V	132 kW	(180 PS)	10	75,60 mm
-------------	-------------------	-------	---	----------------------	----	--------	----------	----	----------

	IN [2] 29,5 x 6 x 100,9	S - -	- 45° - -	22 - III	036 109 601 AD 036 109 601 AK 036 109 601 AL 036 109 601 S 036109601S 03C 109 601 J 03C 109 601 M	<b>39522</b>
	EX [2] 26,0 x 6 x 100,6	RA/S- -	- 45° - VS -	22 - III	036 109 611 AE 036 109 611 K 03C 109 611 G 03C 109 611 R 03C 109 612	<b>39523</b>
	[50] Ø 6 mm				036 109 651A	<b>MK-6H</b>

Fortsetzung nächste Seite / continued on next page / suite page suivante / continuación página próxima / Продолжение на следующей странице

					Reference	Item No.
	IN/EX [4] 11,04 x 6 x 39,0 IN/EX [4] 11,05 x 6 x 36,0 IN/EX [4] 11,15 x 6 x 36,0 EX [4] 11,04 x 6 x 39,0	B1 B1 B1 G2			058 103 415	<b>81-33121</b> <b>81-33111</b> <b>81-33118</b> <b>81-33122</b>
	ES  (1) Schalenhartguss/chilled cast iron/pièce moulée trempée en surface/fundición en coquilla/Отливка с отбеленным поверхностным слоем				03C 109 101 DC	<b>50 007 018</b> (1)
	[8] H 12 x 34,8 x 34,8				030 109 423 030 109 423 A 030 109 423 B 036 109 423 A 036 109 423 D CP40239	<b>50 006 415</b>

## 34 76,5

**CTHE** 05.2010 → 12.2014 B (A) 4 1390 cm<sup>3</sup> 4V 132 kW (180 PS) 10 75,60 mm  
40 846 6..

	IN [2] 29,5 x 6 x 100,9	S - - - 45° - - 22 - III			036 109 601 AD 036 109 601 AK 036 109 601 AL 036 109 601 S 036109601S 03C 109 601 J 03C 109 601 M	<b>39522</b>
	EX [2] 26,0 x 6 x 100,6	RA/S- - - 45° - VS - 22 - III			036 109 611 AE 036 109 611 K 03C 109 611 G 03C 109 611 R 03C 109 612	<b>39523</b>
	[50] Ø 6 mm				036 109 651A	<b>MK-6H</b>
	IN/EX [4] 11,04 x 6 x 39,0 IN/EX [4] 11,05 x 6 x 36,0 IN/EX [4] 11,15 x 6 x 36,0 EX [4] 11,04 x 6 x 39,0	B1 B1 B1 G2			058 103 415	<b>81-33121</b> <b>81-33111</b> <b>81-33118</b> <b>81-33122</b>
	ES AS  (1) Schalenhartguss/chilled cast iron/pièce moulée trempée en surface/fundición en coquilla/Отливка с отбеленным поверхностным слоем				03C 109 101 DC 03C 109 101 DF	<b>50 007 018</b> (1) <b>50 007 019</b> (1)
	[8] H 12 x 34,8 x 34,8				030 109 423 030 109 423 A 030 109 423 B 036 109 423 A 036 109 423 D CP40239	<b>50 006 415</b>

## 35 76,5

**CJLA** 10.2010 → 12.2014 B (NA) 3 1198 cm<sup>3</sup> 4V 55 kW (75 PS) 86,90 mm

	ES AS				03E109101T 03E109101AA	<b>50 007 654</b> <b>50 007 655</b>
--	----------	--	--	--	---------------------------	--

## 36 76,5

**CGPC** 07.2012 → 06.2015 B (NA) 3 1198 cm<sup>3</sup> 4V 55 kW (75 PS) 10,5 86,90 mm

Fortsetzung nächste Seite / continued on next page / suite page suivante / continuación página próxima / Продолжение на следующей странице

					Reference	Item No.
IN [2]	29,5 x 6 x 100,9	S - -	- 45° - -	22 - III	036 109 601 AD 036 109 601 AK 036 109 601 AL 036 109 601 S 036109601S 03C 109 601 J 03C 109 601 M	<b>39522</b>
EX [2]	26,0 x 6 x 100,6	RA/S- -	- 45° - VS -	22 - III	036 109 611 AE 036 109 611 K 03C 109 611 G 03C 109 611 R 03C 109 612	<b>39523</b>
[50]	∅ 6 mm				036 109 651A	<b>MK-6H</b>
IN/EX [4]	11,04 x 6 x 39,0	B1			058 103 415	<b>81-33121</b> <small>NEW</small>
IN/EX [4]	11,05 x 6 x 36,0	B1				<b>81-33111</b>
IN/EX [4]	11,15 x 6 x 36,0	B1				<b>81-33118</b> <small>NEW</small>
EX [4]	11,04 x 6 x 39,0	G2				<b>81-33122</b> <small>NEW</small>
	ES AS				03E109101T 03E109101AA	<b>50 007 654</b> <b>50 007 655</b>
[8]	H 12 x 34,8 x 34,8				030 109 423 030 109 423 A 030 109 423 B 036 109 423 A 036 109 423 D CP40239	<b>50 006 415</b>

## 37

## 76,5

<b>CWVA Euro 5</b>	01.2014 →	B (NA)	4	1598 cm <sup>3</sup>	4V	81 kW	(110 PS)	10,5	86,90 mm
<b>CWVB Euro 5</b>	08.2014 →	B (NA)	4	1598 cm <sup>3</sup>	4V	66 kW	(90 PS)		86,90 mm

41 487 6..

IN [2]	29,6 x 5 x 110,2	S - -	- 45° - -	22 - III	04C 109 601C 04E 109 601	<b>398000</b> <small>NEW</small>
EX [2]	27,0 x 5 x 110,1	A/S - Cr -	- 30° - VS -	22 - III	04C 109 611A 04E 109 611L	<b>398001</b> <small>NEW</small>
[50]	∅ 5 mm					<b>MK-5H</b>
IN [1]	10,06 x 5 x 45,0	B1				<b>81-33123</b> <small>NEW</small>
EX [1]	10,05 x 5 x 45,0	G2				<b>81-33124</b> <small>NEW</small>

## 38

## 78,3

<b>AYM</b>	12.2001 → 08.2003	D (LA)	6	2496 cm <sup>3</sup>	4V	114 kW	(155 PS)	19,5	86,40 mm
------------	-------------------	--------	---	----------------------	----	--------	----------	------	----------

99 534 6.., 99 535 6..

IN [2]	27,2 x 6 x 100,5	S - -	- 45° - -	22 - III	059 109 601 B 059 109 601 C	<b>331055</b>
EX [2]	24,2 x 6 x 100,5	A/S - -	- 45° - VS -	22 - III	059 109 611 B	<b>331056</b>
IN/EX [4]	10,06 x 6 x 42,0	B1				<b>81-33112</b>

Fortsetzung nächste Seite / continued on next page / suite page suivante / continuación página próxima / Продолжение на следующей странице

					Reference	Item No.
	ES				059 109 021 BP 059 109 021 K 059 109 021 Q	<b>50 006 300</b> (1)
	ES				059 109 021 BQ 059 109 021 L 059 109 021 P	<b>50 006 301</b> (2)
	AS				059 109 022 BD 059 109 022 L 059 109 022 P	<b>50 006 302</b> (2)
	AS				059 109 022 BC 059 109 022 K 059 109 022 Q	<b>50 006 303</b> (1)
	(1) für Zylinder/for cylinder/pour cylindre/para cilindro/для цилиндров 1-3 für Zylinder/for cylinder/pour cylindre/para cilindro/для цилиндров 1-3 / Schalenhartguss/chilled cast iron/pièce moulée trempée en surface/fundición en coquilla/Отливка с отбелнным поверхностным слоем  (2) Schalenhartguss/chilled cast iron/pièce moulée trempée en surface/fundición en coquilla/Отливка с отбелнным поверхностным слоем					
	[8]	H 12 x 35 x 35			059 109 521 B 059 109 521 C 059 109 521 E	<b>50 006 411</b>
	[12]				059 109 444	<b>50 006 410</b>

## 39 78,3

**BDG** 06.2003 → 03.2008 D (LA) 6 2496 cm<sup>3</sup> 4V 120 kW (163 PS) 18,5 86,40 mm  
99 542 6..., 99 543 6..

	IN [2] EX [2]	27,2 x 6 x 100,6 24,1 x 6 x 100,7	S - Cr - RA/S- Cr -	- 45° - - - 45° - VS -	22 - III 22 - III	059 109 601F 059 109 611G	<b>331110</b> <b>331111</b>
	IN/EX [4] IN/EX [4]	10,07 x 6 x 36,0 10,12 x 6 x 36,0	B1 B1				<b>81-3323</b> <b>81-3324</b>
	AS					059 109 009 BH 059 109 022 AF 059 109 022 BQ	<b>50 006 344</b> (1)
	AS					059 109 009 BJ 059 109 022 AG 059 109 022 BR	<b>50 006 345</b> (2)
	ES					059 106 021 CK 059 109 021 BA 059 109 021 CR	<b>50 006 346</b> (1)
	ES					059 109 021 AS 059 109 021 CL 059 109 021 CS	<b>50 006 347</b> (2)
	(1) für Zylinder/for cylinder/pour cylindre/para cilindro/для цилиндров 1-3 / Schalenhartguss/chilled cast iron/pièce moulée trempée en surface/fundición en coquilla/Отливка с отбелнным поверхностным слоем  (2) Cylinder 4-6 / Schalenhartguss/chilled cast iron/pièce moulée trempée en surface/fundición en coquilla/Отливка с отбелнным поверхностным слоем						
	[8]	H 12 x 32,6 x 32,6				059 109 521 G	<b>50 006 420</b>

## 40 79,5

**AEF** 10.1995 → 04.2002 D (NA) 4 1896 cm<sup>3</sup> 2V 47 kW (64 PS) 22,5 95,50 mm  
91 386 6..

Fortsetzung nächste Seite / continued on next page / suite page suivante / continuación página próxima / Продолжение на следующей странице

					Reference	Item No.	
	IN [2] IN [2] IN [2] EX [2] EX [2] EX [2] EX [2]	36,0 x 7 x 95,6 36,0 x 7 x 96,6 36,0 x 8 x 95,6 31,0 x 7 x 95,6 31,2 x 8 x 95,1 31,2 x 8 x 95,6 31,5 x 7 x 96,4	S - - S - - S - - A/S - - A/S - - RA/S- Cr - RA/S- -	- 45° - - - 45° - - - 45° - - - 45° - VS - - 45° - VS - - 45° - VS - - 45° - VS -	22 - III 22 - III 22 - III 22 - III 22 - III 22 - III 22 - III	028 109 601 B 028 109 601 J 069 109 601 F 028 109 611 E 074 109 611 074 109 611 028 109 611 K	<b>39395</b> <b>39502</b> <b>39123</b> <b>39474</b> <b>33049</b> <b>39185</b> <b>39503</b>
	[50] [50]	Ø 7 mm Ø 8 mm				021 109 651 113 109 651 A 400 501 068	<b>MK-7H</b> <b>MK-8H</b>
	IN/EX [4] IN/EX [4]  IN/EX [4] IN/EX [4] IN/EX [4]	12,06/15 x 8 x 36,5 12,08/15 x 7 x 36,5  12,13/15 x 8 x 36,5 12,20/15 x 8 x 36,5 12,25/15 x 7 x 36,5	B1 B1  B1 B1 B1			056 103 419 A 037 103 415 037 103 419 B  028 109 101 E	<b>81-3310</b> <b>81-33103</b>  <b>81-3312</b> <b>81-3311</b> <b>81-33104</b>  <b>50 006 204</b> (1)
		(1) Schalenhartguss/chilled cast iron/pièce moulée trempée en surface/fundición en coquilla/Отливка с отбелсным поверхностным слоем					
	[8]	H 35 x 26 x 26				050 109 309 050 109 309 A 050 109 309 H 050 109 309 J	<b>50 006 417</b>

## 41 79,5

<b>AGR</b>	09.1996 → 03.2010	D (LA)	4	1896 cm <sup>3</sup>	2V	66 kW	(90 PS)	19,5	95,50 mm
<b>AHF</b>	08.1997 → 01.2006	D (LA)	4	1896 cm <sup>3</sup>	2V	81 kW	(110 PS)	19,5	95,50 mm

94 427 7.., 94 428 7..

	IN [2] EX [2]	36,0 x 7 x 96,9 31,6 x 7 x 96,9	S - - RA/S- -	- 45° - - - 45° - -	22 - III 22 - III	028 109 601 D 028 109 611G	<b>39486</b> <b>331143</b>
	[50]	Ø 7 mm				021 109 651	<b>MK-7H</b>
	IN/EX [4] IN/EX [4]	12,08/15 x 7 x 36,5 12,25/15 x 7 x 36,5	B1 B1			037 103 415 037 103 419 B	<b>81-33103</b> <b>81-33104</b>
		(1) Schalenhartguss/chilled cast iron/pièce moulée trempée en surface/fundición en coquilla/Отливка с отбелсным поверхностным слоем				038 109 101 K	<b>50 006 202</b> (1)
	[8]	H 35 x 26 x 26				050 109 309 050 109 309 A 050 109 309 H 050 109 309 J	<b>50 006 417</b>
	[8]	H 35 x 26 x 26				034 109 309 034 109 309 AC 034 109 309 AD 034 109 309 N 074 109 309	<b>50 006 460</b>

## 42 79,5

<b>ALH</b>	09.1996 → 03.2010	D (LA)	4	1896 cm <sup>3</sup>	2V	66 kW	(90 PS)	19,5	95,50 mm
<b>ASV</b>	08.1997 → 01.2006	D (LA)	4	1896 cm <sup>3</sup>	2V	81 kW	(110 PS)	19,5	95,50 mm

94 427 7.., 94 428 7..

	IN [2] EX [2]	36,0 x 7 x 96,9 31,6 x 7 x 96,9	S - - RA/S- -	- 45° - - - 45° - -	22 - III 22 - III	028 109 601 D 028 109 611G	<b>39486</b> <b>331143</b>
--	------------------	------------------------------------	------------------	------------------------	----------------------	-------------------------------	-------------------------------

Fortsetzung nächste Seite / continued on next page / suite page suivante / continuación página próxima / Продолжение на следующей странице

					Reference	Item No.
[50]	Ø 7 mm				021 109 651	<b>MK-7H</b>
IN/EX [4]	12,08/15 x 7 x 36,5	B1			037 103 415	<b>81-33103</b>
IN/EX [4]	12,25/15 x 7 x 36,5	B1			037 103 419 B	<b>81-33104</b>
					038 109 101 K	<b>50 006 202</b> (1)
	(1) Schalenhartguss/chilled cast iron/pièce moulée trempée en surface/fundición en coquilla/Отливка с отбелнным поверхностным слоем					
[8]	H 35 x 26 x 26				050 109 309 050 109 309 A 050 109 309 H 050 109 309 J	<b>50 006 417</b>

## 43 79,5

AGP 06.1997 → 12.2003 D (NA) 4 1896 cm<sup>3</sup> 2V 50 kW (68 PS) 19,5 95,50 mm  
40 092 7..., 40 093 7..

IN [2]	36,0 x 7 x 96,6	S - -	- 45° - -	22 - III	028 109 601 J	<b>39502</b>
IN [2]	36,0 x 8 x 95,6	S - -	- 45° - -	22 - III	069 109 601 F	<b>39123</b>
EX [2]	31,2 x 8 x 95,1	A/S - -	- 45° - VS -	22 - III	074 109 611	<b>33049</b>
EX [2]	31,2 x 8 x 95,6	RA/S- Cr -	- 45° - VS -	22 - III	074 109 611	<b>39185</b>
EX [2]	31,5 x 7 x 96,4	RA/S- -	- 45° - VS -	22 - III	028 109 611 K	<b>39503</b>
[50]	Ø 7 mm				021 109 651	<b>MK-7H</b>
[50]	Ø 8 mm				113 109 651 A 400 501 068	<b>MK-8H</b>
IN/EX [4]	12,06/15 x 8 x 36,5	B1			056 103 419 A	<b>81-3310</b>
IN/EX [4]	12,08/15 x 7 x 36,5	B1			037 103 415 037 103 419 B	<b>81-33103</b>
IN/EX [4]	12,13/15 x 8 x 36,5	B1				<b>81-3312</b>
IN/EX [4]	12,20/15 x 8 x 36,5	B1				<b>81-3311</b>
IN/EX [4]	12,25/15 x 7 x 36,5	B1				<b>81-33104</b>
					038 109 101 E	<b>50 006 210</b> (1)
	(1) Schalenhartguss/chilled cast iron/pièce moulée trempée en surface/fundición en coquilla/Отливка с отбелнным поверхностным слоем					
[8]	H 35 x 26 x 26				050 109 309 050 109 309 A 050 109 309 H 050 109 309 J	<b>50 006 417</b>

## 44 79,5

AQM 06.1997 → 12.2003 D (NA) 4 1896 cm<sup>3</sup> 2V 50 kW (68 PS) 19,5 95,50 mm  
ASY 11.1999 → 03.2008 D (NA) 4 1896 cm<sup>3</sup> 2V 47 kW (64 PS) 19,5 95,50 mm  
40 092 7..., 40 093 7..

IN [2]	36,0 x 7 x 96,6	S - -	- 45° - -	22 - III	028 109 601 J	<b>39502</b>
EX [2]	31,5 x 7 x 96,4	RA/S- -	- 45° - VS -	22 - III	028 109 611 K	<b>39503</b>
[50]	Ø 7 mm				021 109 651	<b>MK-7H</b>
IN/EX [4]	12,08/15 x 7 x 36,5	B1			037 103 415 037 103 419 B	<b>81-33103</b>
IN/EX [4]	12,25/15 x 7 x 36,5	B1				<b>81-33104</b>
					038 109 101 E	<b>50 006 210</b> (1)
	(1) Schalenhartguss/chilled cast iron/pièce moulée trempée en surface/fundición en coquilla/Отливка с отбелнным поверхностным слоем					

Fortsetzung nächste Seite / continued on next page / suite page suivante / continuación página próxima / Продолжение на следующей странице



					Reference	Item No.
[8]	H 35 x 26 x 26				050 109 309 050 109 309 A 050 109 309 H 050 109 309 J	<b>50 006 417</b>
<b>45</b> <b>79,5</b>						
<b>ATD</b>	01.2000 → 03.2008	D (LA)	4	1896 cm <sup>3</sup>	2V 74 kW (100 PS) 19,5	95,50 mm
<b>AVB</b>	08.2002 → 10.2005	D (LA)	4	1896 cm <sup>3</sup>	2V 74 kW (101 PS) 19	95,50 mm
99 850 6.., 99 851 6..						
IN [2]	35,9 x 7 x 89,9	S - -	- 45° - -	22 - III	038 109 601 B 038109601B	<b>331033</b>
EX [2]	31,5 x 7 x 90,0	A/S - -	- 45° - VS -	22 - III	038 109 611 B 038 109 611 F 038109611B	<b>331034</b>
[50]	Ø 7 mm				021 109 651	<b>MK-7H</b>
IN/EX [4]	12,07 x 7 x 31,5	B1				<b>81-33115</b>
					038 109 101 R	<b>50 006 304</b> (1)
	(1) Alloy Steel SAE 8620 / (ST)					
[8]	H 35 x 26 x 26				038 109 309 A 038 109 309 B 038 109 309 C	<b>50 006 418</b>
[1]					038109527AF	<b>50 007 650</b> (2)
	(2) Kipphebeleinheit - nicht voreingestellt! rocker shaft assembly - not preset! Unité culbuteur - n'est pas pré réglée! Unidad de balancines: no preajustada! Узел коромысла — без предварительной настройки!					
		- - G - S -	- SB - -		038 103 351 D 03G 103 351 C 03G 103 351 D	<b>50 003 131</b>
					40 Nm 60 Nm - 90° + 60 Nm 90° 90°	
		CAM - V - G - S -	- SB - -	ready-to-install		<b>50 003 431</b> (3)
	(3) Nockenwelle/camshaft/arbre à cames/árbol de levas/кулачковый вал OE# 038 109 101R					
<b>46</b> <b>79,5</b>						
<b>AXR</b>	01.2000 → 12.2010	D (LA)	4	1896 cm <sup>3</sup>	2V 74 kW (100 PS) 19	95,50 mm
<b>BKC</b>	06.2004 → 12.2010	D (LA)	4	1896 cm <sup>3</sup>	2V 77 kW (105 PS) 19	95,50 mm
99 850 6.., 99 851 6..						
IN [2]	36,0 x 7 x 89,5	S - -	- 45° - -	22 - III	038 109 601 E	<b>331123</b>
EX [2]	31,5 x 7 x 89,0	RA/S- -	- 45° - VS -	22 - III	038 109 611 E	<b>331124</b>
[50]	Ø 7 mm				021 109 651	<b>MK-7H</b>
IN/EX [4]	12,07 x 7 x 31,5	B1				<b>81-33115</b>
Fortsetzung nächste Seite / continued on next page / suite page suivante / continuación página próxima / Продолжение на следующей странице						

S

					Reference	Item No.
	(1) Alloy Steel SAE 8620 / (ST)				038 109 101 R	<b>50 006 304</b> (1)
	[8] H 35 x 26 x 26				038 109 309 A 038 109 309 B 038 109 309 C	<b>50 006 418</b>
	[1]  (2) Kipphebeleinheit - nicht voreingestellt! rocker shaft assembly - not preset! Unité culbuteur - n'est pas pré réglée! Unidad de balancines: no preajustada! Узел коромысла — без предварительной настройки!				038109527AF	<b>50 007 650</b> (2)
	- - G - S - - SB - -  CAM - V - G - S - - SB - -  (3) Nockenwelle/camshaft/arbre à cames/árbol de levas/кулачковый вал OE# 038 109 101R				038 103 351 D 03G 103 351 C 03G 103 351 D	<b>50 003 131</b>  <b>50 003 431</b> (3)

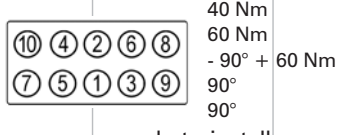

## 47

## 79,5

ASZ	01.2003 → 03.2008	D (LA)	4	1896 cm <sup>3</sup>	2V	96 kW	(130 PS)	19	95,50 mm
AVF	12.2001 → 03.2008	D (LA)	4	1896 cm <sup>3</sup>	2V	96 kW	(130 PS)	19:1	95,50 mm
AWX	12.2001 → 03.2008	D (LA)	4	1896 cm <sup>3</sup>	2V	96 kW	(130 PS)	19:1	95,50 mm

99 470 6..

	IN [2]	35,9 x 7 x 89,9	S - -	- 45° - -	22 - III	038 109 601 B 038109601B	<b>331033</b>
	EX [2]	31,5 x 7 x 90,0	A/S - -	- 45° - VS -	22 - III	038 109 611 B 038 109 611 F 038109611B	<b>331034</b>
	[50]	Ø 7 mm				021 109 651	<b>MK-7H</b>
	IN/EX [4]	12,08/15 x 7 x 36,5	B1			037 103 415 037 103 419 B	<b>81-33103</b>
	IN/EX [4]	12,08/15 x 7 x 38,0	B1			027 103 419	<b>81-33100</b>
	IN/EX [4]	12,25/15 x 7 x 36,5	B1				<b>81-33104</b>
	(1) Alloy Steel SAE 8620 / (ST)					038 109 101 R	<b>50 006 304</b> (1)
	[8] H 35 x 26 x 26					038 109 309 A 038 109 309 B 038 109 309 C	<b>50 006 418</b>
	[1]  (2) Kipphebeleinheit - nicht voreingestellt! rocker shaft assembly - not preset! Unité culbuteur - n'est pas pré réglée! Unidad de balancines: no preajustada! Узел коромысла — без предварительной настройки!					038109527AF	<b>50 007 650</b> (2)

Fortsetzung nächste Seite / continued on next page / suite page suivante / continuación página próxima / Продолжение на следующей странице

					Reference	Item No.
	- - G - S -	- SB - -			038 103 351 D 03G 103 351 C 03G 103 351 D	<b>50 003 131</b>
	CAM - V - G - S -	- SB - -	 40 Nm 60 Nm - 90° + 60 Nm 90° 90° ready-to-install			<b>50 003 431</b> (3)
(3) Nockenwelle/camshaft/arbre à cames/árbol de levas/кулачковый вал OE# 038 109 101R						

<b>48</b>		<b>79,5</b>																				
AMF		04.2003 → 03.2008		D	(A)	3	1422 cm <sup>3</sup>	2V	55 kW	(75 PS)	19,5	95,50 mm										
41 158 6.., 41 159 6..																						
	IN [2]	35,9 x 7 x 89,9	S - -	- 45° - -	22 - III	038 109 601 B 038109601B	<b>331033</b>															
	IN [2]	36,0 x 7 x 89,5	S - -	- 45° - -	22 - III	038 109 601 E	<b>331123</b>															
	EX [2]	31,5 x 7 x 89,0	RA/S- -	- 45° - VS -	22 - III	038 109 611 E	<b>331124</b>															
	EX [2]	31,5 x 7 x 90,0	A/S - -	- 45° - VS -	22 - III	038 109 611 B 038 109 611 F 038109611B	<b>331034</b>															
	[50]	Ø 7 mm				021 109 651	<b>MK-7H</b>															
	IN/EX [4]	12,08/15 x 7 x 36,5	B1			037 103 415 037 103 419 B	<b>81-33103</b>															
	IN/EX [4]	12,08/15 x 7 x 38,0	B1			027 103 419	<b>81-33100</b>															
	IN/EX [4]	12,25/15 x 7 x 36,5	B1				<b>81-33104</b>															
						045 109 101 C	<b>50 006 388</b>															
	[8]	H 35 x 26 x 26				038 109 309 A 038 109 309 B 038 109 309 C	<b>50 006 418</b>															

<b>49</b>		<b>79,5</b>																				
BLT		06.2003 → 03.2008		D	(LA)	4	1896 cm <sup>3</sup>	2V	96 kW	(130 PS)	19	95,50 mm										
99 470 6..																						
	IN [2]	35,9 x 7 x 89,9	S - -	- 45° - -	22 - III	038 109 601 B 038109601B	<b>331033</b>															
	IN [2]	36,0 x 7 x 89,5	S - -	- 45° - -	22 - III	038 109 601 E	<b>331123</b>															
	EX [2]	31,5 x 7 x 89,0	RA/S- -	- 45° - VS -	22 - III	038 109 611 E	<b>331124</b>															
	EX [2]	31,5 x 7 x 90,0	A/S - -	- 45° - VS -	22 - III	038 109 611 B 038 109 611 F 038109611B	<b>331034</b>															
	[50]	Ø 7 mm				021 109 651	<b>MK-7H</b>															
	IN/EX [4]	12,08/15 x 7 x 36,5	B1			037 103 415 037 103 419 B	<b>81-33103</b>															
	IN/EX [4]	12,25/15 x 7 x 36,5	B1				<b>81-33104</b>															
						038 109 101 R	<b>50 006 304</b>	(1)														
(1) Alloy Steel SAE 8620 / (ST)																						
	[1]					038109527AF	<b>50 007 650</b>	(2)														

Fortsetzung nächste Seite / continued on next page / suite page suivante / continuación página próxima / Продолжение на следующей странице

					Reference	Item No.
(2)	Kipphebeleinheit - nicht voreingestellt! rocker shaft assembly - not preset! Unité culbuteur - n'est pas pré réglée! Unidad de balancines: no preajustada! Узел коромысла — без предварительной настройки!					
	- - G - S -	- SB - -			038 103 351 D 03G 103 351 C 03G 103 351 D	<b>50 003 131</b>
				40 Nm 60 Nm - 90° + 60 Nm 90° 90°		
	CAM - V - G - S -	- SB - -	ready-to-install			<b>50 003 431</b> (3)
(3)	Nockenwelle/camshaft/arbre à cames/árbol de levas/кулачковый вал OE# 038 109 101R					

## 50 79,5

**BJB** 06.2004 → 12.2010 D (LA) 4 1896 cm<sup>3</sup> 2V 77 kW (105 PS) 19 95,50 mm  
40 421 6.., 40 422 6.., 99 850 6.., 99 851 6..

	IN [2] EX [2]	36,0 x 7 x 89,5 31,5 x 7 x 89,0	S - - RA/S- -	- 45° - - - 45° - VS -	22 - III 22 - III	038 109 601 E 038 109 611 E	<b>331123</b> <b>331124</b>
	[50]	∅ 7 mm				021 109 651	<b>MK-7H</b>
	IN/EX [4]	12,08/15 x 7 x 36,5	B1			037 103 415 037 103 419 B	<b>81-33103</b>
	IN/EX [4]	12,25/15 x 7 x 36,5	B1				<b>81-33104</b>
	[8]	H 35 x 26 x 26				038 109 309 A 038 109 309 B 038 109 309 C	<b>50 006 418</b>
	[1]					038109527AF	<b>50 007 650</b> (1)
(1)	Kipphebeleinheit - nicht voreingestellt! rocker shaft assembly - not preset! Unité culbuteur - n'est pas pré réglée! Unidad de balancines: no preajustada! Узел коромысла — без предварительной настройки!						

	- - G - S -	- SB - -				038 103 351 D 03G 103 351 C 03G 103 351 D	<b>50 003 131</b>
				40 Nm 60 Nm - 90° + 60 Nm 90° 90°			
	CAM - V - G - S -	- SB - -	ready-to-install				<b>50 003 431</b> (2)
(2)	Nockenwelle/camshaft/arbre à cames/árbol de levas/кулачковый вал OE# 038 109 101R						

## 51 79,5

**BLS** 06.2004 → 12.2010 D (LA) 4 1896 cm<sup>3</sup> 2V 77 kW (105 PS) 19:1 95,50 mm  
40 421 6.., 40 422 6..

	IN [2] EX [2]	36,0 x 7 x 89,5 31,5 x 7 x 89,0	S - - RA/S- -	- 45° - - - 45° - VS -	22 - III 22 - III	038 109 601 E 038 109 611 E	<b>331123</b> <b>331124</b>
	[50]	∅ 7 mm				021 109 651	<b>MK-7H</b>

Fortsetzung nächste Seite / continued on next page / suite page suivante / continuación página próxima / Продолжение на следующей странице

					Reference	Item No.
	IN/EX [4]	12,07 x 7 x 31,5	B1			<b>81-33115</b> <small>NEW</small>
					038 109 101 R	<b>50 006 304</b> (1)
	(1)	Aloy Steel SAE 8620 / (ST)				
	[8]	H 35 x 26 x 26			038 109 309 A 038 109 309 B 038 109 309 C	<b>50 006 418</b>
	[1]				038109527AF	<b>50 007 650</b> (2)
	(2)	Kipphebeleinheit - nicht voreingestellt! rocker shaft assembly - not preset! Unité culbuteur - n'est pas pré réglée! Unidad de balancines: no preajustada! Узел коромысла — без предварительной настройки!				
		- - G - S -	- SB - -			038 103 351 D 03G 103 351 C 03G 103 351 D
					40 Nm 60 Nm - 90° + 60 Nm 90° 90°	

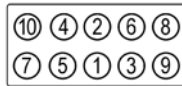

<b>52</b>		<b>79,5</b>				
<b>BXE</b>	06.2004 → 12.2010	D (LA)	4	1896 cm <sup>3</sup>	2V	77 kW (105 PS) 19 95,50 mm
40 421 6.., 40 422 6.., 99 850 6.., 99 851 6..						

	IN [2] EX [2]	36,0 x 7 x 89,5 31,5 x 7 x 89,0	S - - RA/S- -	- 45° - - - 45° - VS -	22 - III 22 - III	038 109 601 E 038 109 611 E	<b>331123</b> <b>331124</b>
	[50]	Ø 7 mm				021 109 651	<b>MK-7H</b>
	IN/EX [4]	12,07 x 7 x 31,5	B1				<b>81-33115</b> <small>NEW</small>
	[8]	H 35 x 26 x 26				038 109 309 A 038 109 309 B 038 109 309 C	<b>50 006 418</b>
	[1]					038109527AF	<b>50 007 650</b> (1)
	(1)	Kipphebeleinheit - nicht voreingestellt! rocker shaft assembly - not preset! Unité culbuteur - n'est pas pré réglée! Unidad de balancines: no preajustada! Узел коромысла — без предварительной настройки!					
		- - G - S -	- SB - -			038 103 351 D 03G 103 351 C 03G 103 351 D	<b>50 003 131</b>
					40 Nm 60 Nm - 90° + 60 Nm 90° 90°		
		CAM - V - G - S -	- SB - -	ready-to-install			<b>50 003 431</b> (2)
	(2)	Nockenwelle/camshaft/arbre à cames/árbol de levas/кулачковый вал OE# 038 109 101R					

**S**

					Reference	Item No.	
<b>53</b>		<b>79,5</b>					
<b>BPZ</b>		01.2007 → 03.2008	D (LA)	4	1896 cm <sup>3</sup> 2V	85 kW (115 PS) 19	95,50 mm
<b>BSV</b>		10.2005 → 05.2007	D (LA)	4	1896 cm <sup>3</sup> 2V	77 kW (105 PS) 19	95,50 mm
	IN [2] EX [2]	36,0 x 7 x 89,5 31,5 x 7 x 89,0	S - - RA/S- -	- 45° - - - 45° - VS -	22 - III 22 - III	038 109 601 E 038 109 611 E	<b>331123</b> <b>331124</b>
	[50]	∅ 7 mm				021 109 651	<b>MK-7H</b>
	IN/EX [4] IN/EX [4]	12,08/15 x 7 x 36,5 12,25/15 x 7 x 36,5	B1 B1			037 103 415 037 103 419 B	<b>81-33103</b> <b>81-33104</b>
	(1) (ST)					038 109 101 AH	<b>50 006 342</b> (1)
	[1]  (2) Kipphebeleinheit - nicht voreingestellt! rocker shaft assembly - not preset! Unité culbuteur - n'est pas pré réglée! Unidad de balancines: no preajustada! Узел коромысла — без предварительной настройки!					038109527AF	<b>50 007 650</b> (2)
	- - G - S -	- SB - -				038 103 351 D 03G 103 351 C 03G 103 351 D	<b>50 003 131</b>
					40 Nm 60 Nm - 90° + 60 Nm 90° 90°		
<b>54</b>		<b>79,5</b>					
<b>BNM</b>		10.2005 → 03.2010	D (LA)	3	1422 cm <sup>3</sup> 2V	51 kW (70 PS) 19,5	95,50 mm
<b>BNV</b>		10.2005 → 03.2010	D (LA)	3	1422 cm <sup>3</sup> 2V	59 kW (80 PS) 19,5	95,50 mm
		41 158 6..., 41 159 6..					
	IN [2] EX [2]	36,0 x 7 x 89,5 31,5 x 7 x 89,0	S - - RA/S- -	- 45° - - - 45° - VS -	22 - III 22 - III	038 109 601 E 038 109 611 E	<b>331123</b> <b>331124</b>
	[50]	∅ 7 mm				021 109 651	<b>MK-7H</b>
	IN/EX [4] IN/EX [4]	12,08/15 x 7 x 36,5 12,25/15 x 7 x 36,5	B1 B1			037 103 415 037 103 419 B	<b>81-33103</b> <b>81-33104</b>
						045 109 101 C	<b>50 006 388</b>
	[8] H	35 x 26 x 26				038 109 309 A 038 109 309 B 038 109 309 C	<b>50 006 418</b>
<b>55</b>		<b>79,5</b>					
<b>BMS</b>		09.2006 → 03.2010	D (LA)	3	1422 cm <sup>3</sup> 2V	59 kW (80 PS) 19,5	95,50 mm
		41 158 6..., 41 159 6..					
	IN [2] EX [2]	36,0 x 7 x 89,5 31,5 x 7 x 89,0	S - - RA/S- -	- 45° - - - 45° - VS -	22 - III 22 - III	038 109 601 E 038 109 611 E	<b>331123</b> <b>331124</b>
	[50]	∅ 7 mm				021 109 651	<b>MK-7H</b>
Fortsetzung nächste Seite / continued on next page / suite page suivante / continuación página próxima / Продолжение на следующей странице							



					Reference	Item No.
	IN/EX [4]	12,08/15 x 7 x 36,5	B1		037 103 415 037 103 419 B	<b>81-33103</b>
	IN/EX [4]	12,25/15 x 7 x 36,5	B1			<b>81-33104</b>
	(1) (ST)				045109101J	<b>50 007 633</b> (1)

**56**
**79,5**

**BSW** 09.2006 → 03.2010 D (LA) 4 1896 cm<sup>3</sup> 2V 77 kW (105 PS) 18,5:1 95,50 mm  
99 850 6.., 99 851 6..

	IN [2]	35,9 x 7 x 89,9	S - -	- 45° - -	22 - III	038 109 601 B 038109601B	<b>331033</b>	
	EX [2]	31,5 x 7 x 89,0	RA/S- -	- 45° - VS -	22 - III	038 109 611 E	<b>331124</b>	
	[50]	Ø 7 mm				021 109 651	<b>MK-7H</b>	
	IN/EX [4]	12,08/15 x 7 x 36,5	B1			037 103 415 037 103 419 B	<b>81-33103</b>	
	IN/EX [4]	12,08/15 x 7 x 38,0	B1			027 103 419	<b>81-33100</b>	
	IN/EX [4]	12,25/15 x 7 x 36,5	B1				<b>81-33104</b>	
	[1]					038109527AF	<b>50 007 650</b> (1)	
	(1)	Kipphebeleinheit - nicht voreingestellt! rocker shaft assembly - not preset! Unité culbuteur - n'est pas pré réglée! Unidad de balancines: no preajustada! Узел коромысла — без предварительной настройки!						
		- - G - S -	- SB - -			038 103 351 D 03G 103 351 C 03G 103 351 D	<b>50 003 131</b>	
						40 Nm 60 Nm - 90° + 60 Nm 90° 90°		
		CAM - V - G - S -	- SB - -		ready-to-install		<b>50 003 431</b> (2)	
	(2)	Nockenwelle/camshaft/arbre à cames/árbol de levas/кулачковый вал OE# 038 109 101R						

**57**
**79,5**

**CAYB Euro 5** 03.2010 → D (LA) 4 1598 cm<sup>3</sup> 4V 66 kW (90 PS) 16,5 80,50 mm  
**CAYC** 06.2009 → D (LA) 4 1598 cm<sup>3</sup> 4V 77 kW (105 PS) 16,5 80,50 mm  
**CLNA Euro 5** 10.2011 → 12.2019 D (LA) 4 1598 cm<sup>3</sup> 4V 77 kW (105 PS) 16,5 80,50 mm  
41 095 6..

	IN [2]	26,6 x 6 x 99,3	S - -	- 45° - -	22 - III	03L 109 601A 04L 109 601A	<b>331151</b>
	EX [2]	24,5 x 6 x 99,1	A/S - -	- 45° - VS -	22 - III	03L 109 611A 04L 109 611A	<b>331154</b>
	[50]	Ø 6 mm				036 109 651A	<b>MK-6H</b>
	IN/EX [4]	10,06 x 6 x 36,0	B1				<b>81-33116</b>
	IN/EX [4]	10,21 x 6 x 36,0	B1				<b>81-33117</b>
	ES					03L 109 021 03L 109 021 D 03L 109 021 E	<b>50 007 020</b> (1)
	AS					03L 109 022 03L 109 022 D	<b>50 007 022</b> (1)

Fortsetzung nächste Seite / continued on next page / suite page suivante / continuación página próxima / Продолжение на следующей странице

					Reference	Item No.
(1)	Schalenhartguss/chilled cast iron/pièce moulée trempée en surface/fundición en coquilla/Отливка с отбелнным поверхностным слоем					
[8]	H 12 x 32,5				03L 109 521 03L 109 521 A	<b>50 006 490</b>
[4]					059 109 417 A 059 109 417 B 059 109 417 C 059 109 417 F 059 109 417 G 059109417J	<b>50 006 171</b>

**58**
**79,5**
**CFWA** 03.2010 → D (A) 3 1199 cm<sup>3</sup> 4V 55 kW (75 PS) 16,5 80,50 mm  
 41 095 6..

IN [2]	26,6 x 6 x 99,3	S - -	- 45° - -	22 - III	03L 109 601A 04L 109 601A	<b>331151</b>
EX [2]	24,5 x 6 x 99,1	A/S - -	- 45° - VS -	22 - III	03L 109 611A 04L 109 611A	<b>331154</b>
[50]	∅ 6 mm				036 109 651A	<b>MK-6H</b>
IN/EX [4]	10,06 x 6 x 36,0	B1				<b>81-33116</b>
IN/EX [4]	10,21 x 6 x 36,0	B1				<b>81-33117</b>
	ES AS				03P 109 021 03P 109 022	<b>50 007 675</b> (1) <b>50 007 676</b> (1)
(1)	Schalenhartguss/chilled cast iron/pièce moulée trempée en surface/fundición en coquilla/Отливка с отбелнным поверхностным слоем					
[8]	H 12 x 32,5				03L 109 521 03L 109 521 A	<b>50 006 490</b>
[4]					059 109 417 A 059 109 417 B 059 109 417 C 059 109 417 F 059 109 417 G 059109417J	<b>50 006 171</b>

**59**
**79,5**
**CAYA** 04.2010 → 12.2014 D (LA) 4 1598 cm<sup>3</sup> 4V 55 kW (75 PS) 16,5 80,50 mm  
**CLHA Euro 5** 11.2012 → D (LA) 4 1598 cm<sup>3</sup> 4V 77 kW (105 PS) 16,2 80,50 mm  
**CLHB Euro 5** 11.2012 → D (LA) 4 1598 cm<sup>3</sup> 4V 66 kW (90 PS) 16,2 80,50 mm  
**CRKB Filter** 05.2013 → D (LA) 4 1598 cm<sup>3</sup> 4V 81 kW (110 PS) 16,2 80,50 mm  
 41 095 6.., 41 271 6..

IN [2]	26,6 x 6 x 99,3	S - -	- 45° - -	22 - III	03L 109 601A 04L 109 601A	<b>331151</b>
EX [2]	24,5 x 6 x 99,1	A/S - -	- 45° - VS -	22 - III	03L 109 611A 04L 109 611A	<b>331154</b>
[50]	∅ 6 mm				036 109 651A	<b>MK-6H</b>
IN/EX [4]	10,06 x 6 x 36,0	B1				<b>81-33116</b>
IN/EX [4]	10,21 x 6 x 36,0	B1				<b>81-33117</b>
[8]	H 12 x 32,5				03L 109 521 03L 109 521 A	<b>50 006 490</b>

Fortsetzung nächste Seite / continued on next page / suite page suivante / continuación página próxima / Продолжение на следующей странице

					Reference	Item No.
[4]					059 109 417 A 059 109 417 B 059 109 417 C 059 109 417 F 059 109 417 G 059109417J	<b>50 006 171</b>

<b>60</b>		<b>79,5</b>							
<b>CUSA Euro 6</b>	05.2015 →	D (LA)	3	1422 cm <sup>3</sup>	4V	55 kW	(75 PS)	16,2	95,50 mm
<b>CUSB Euro 6</b>	08.2014 →	D (LA)	3	1422 cm <sup>3</sup>	4V	66 kW	(90 PS)	16,2	95,50 mm
<b>CUTA Euro 6</b>	08.2014 →	D (LA)	3	1422 cm <sup>3</sup>	4V	77 kW	(105 PS)	16,2	95,50 mm
<b>CXXA Euro 6</b>	11.2012 →	D (LA)	4	1598 cm <sup>3</sup>	4V	66 kW	(90 PS)	16,2	80,50 mm
<b>CXXB Euro 6</b>	05.2013 →	D (LA)	4	1598 cm <sup>3</sup>	4V	81 kW	(110 PS)	16,2	80,50 mm

IN [2]	26,6 x 6 x 99,3	S - -	- 45° - -	22 - III	03L 109 601A 04L 109 601A	<b>331151</b>
EX [2]	24,5 x 6 x 99,1	A/S - -	- 45° - VS -	22 - III	03L 109 611A 04L 109 611A	<b>331154</b>
[50]	Ø 6 mm				036 109 651A	<b>MK-6H</b>
IN/EX [4]	10,06 x 6 x 36,0	B1				<b>81-33116</b>
IN/EX [4]	10,21 x 6 x 36,0	B1				<b>81-33117</b>

<b>61</b>		<b>79,5</b>							
<b>DDYA Euro 6</b>	02.2017 →	D (LA)	4	1598 cm <sup>3</sup>	4V	85 kW	(115 PS)	16,2	80,50 mm
<b>DDYB Euro 6</b>	11.2012 →	D (LA)	4	1598 cm <sup>3</sup>	4V	66 kW	(90 PS)	16,2	80,50 mm
<b>DGTE Euro 6</b>	02.2017 →	D (LA)	4	1598 cm <sup>3</sup>	4V	85 kW	(115 PS)		80,50 mm

IN [2]	26,6 x 6 x 99,3	S - -	- 45° - -	22 - III	03L 109 601A 04L 109 601A	<b>331151</b>
EX [2]	24,5 x 6 x 99,1	A/S - -	- 45° - VS -	22 - III	03L 109 611A 04L 109 611A	<b>331154</b>
[50]	Ø 6 mm				036 109 651A	<b>MK-6H</b>

<b>62</b>		<b>79,5</b>							
<b>DBKA Euro 6</b>	05.2013 →	D (LA)	4	1598 cm <sup>3</sup>	4V	81 kW	(110 PS)	16,2	80,50 mm

IN [2]	26,6 x 6 x 99,3	S - -	- 45° - -	22 - III	03L 109 601A 04L 109 601A	<b>331151</b>
IN [2]	28,1 x 6 x 99,3	S - -	- 45° - -	22 - III	03L 109 601 04L 109 601B	<b>331131</b>
EX [2]	24,5 x 6 x 99,1	A/S - -	- 45° - VS -	22 - III	03L 109 611A 04L 109 611A	<b>331154</b>
EX [2]	26,0 x 6 x 99,1	RA/S- -	- 45° - VS -	22 - III	03L 109 611 04L 109 611B 04L 109 611C	<b>331132</b>
[50]	Ø 6 mm				036 109 651A	<b>MK-6H</b>
IN/EX [4]	10,06 x 6 x 36,0	B1				<b>81-33116</b>
IN/EX [4]	10,06 x 6 x 42,0	B1				<b>81-33112</b>
IN/EX [4]	10,21 x 6 x 36,0	B1				<b>81-33117</b>

<b>63</b>		<b>81</b>							
<b>CHGA</b>	08.2009 → 11.2012	BG (NA)	4	1595 cm <sup>3</sup>	2V	75 kW	(102 PS)		77,40 mm

IN/EX [4]	12,06 x 5,99 x 36,4	B1							<b>81-33113</b>
IN/EX [4]	12,08 x 5,98 x 36,5	B1							<b>81-33114</b>

**S**

					Reference	Item No.		
<b>64</b>	<b>81</b>							
<b>AGN</b>	09.1996 → 07.2000	B	(NA)	4	1781 cm <sup>3</sup> 5V	92 kW (125 PS) 10,3	86,40 mm	
	IN [2]	27,0 x 6 x 105,1	S	- -	- 45° - VS -	22 - III	058 109 601 C 058 109 601 P 058109601C	<b>33413</b>
	EX [2]	30,1 x 6 x 103,9	RA/S-	Cr -	- 45° - VS -	22 - III	058 109 611 M 06B 109 611 D	<b>331107</b>
	[50]	∅ 6 mm					036 109 651A	<b>MK-6H</b>
	IN/EX [4]	11,04 x 6 x 39,0	B1				058 103 415	<b>81-33121</b>
	IN/EX [4]	11,05 x 6 x 36,0	B1					<b>81-33111</b>
	IN/EX [4]	11,15 x 6 x 36,0	B1					<b>81-33118</b>
	EX [4]	11,04 x 6 x 39,0	G2					<b>81-33122</b>
	[8]	H 24 x 24 x 24					058 109 309 B 058 109 309 F 058 109 309 J	<b>50 006 425</b> (1)
	[8]	H 33,5 x 25,6 x 25,6					058 109 309 A 058 109 309 E 058 109 309 K	<b>50 006 426</b> (2)
		(1) Einlass/intake/admission/entrada/коллектора						
		(2) Auslass/Exhaust/sortie/salida/Выпуск						
<b>65</b>	<b>81</b>							
<b>AEH</b>	02.1997 → 12.2007	B	(NA)	4	1595 cm <sup>3</sup> 2V	74 kW (101 PS) 10,3	77,40 mm	
<b>AKL</b>	02.1997 → 12.2007	B	(NA)	4	1595 cm <sup>3</sup> 2V	74 kW (101 PS) 10,2	77,40 mm	
94 503 7..								
	IN [2]	39,5 x 7 x 91,9	S	- -	- 45° - -	22 - III	06A 109 601E 078 109 601A 078 109 601B 078 109 601E 078 109 601F 078109601B	<b>33403</b>
	EX [2]	33,0 x 7 x 91,2	A/S	- -	- 45° - VS -	22 - III	048 109 611B 078 109 611C	<b>33416</b>
	[50]	∅ 7 mm					021 109 651	<b>MK-7H</b>
	IN/EX [4]	12,08/15 x 7 x 36,5	B1				037 103 415 037 103 419 B	<b>81-33103</b>
	IN/EX [4]	12,25/15 x 7 x 36,5	B1					<b>81-33104</b>
							050 109 101A	<b>50 006 398</b> (1)
		(1) Schalenhartguss/chilled cast iron/pièce moulée trempée en surface/fundición en coquilla/Отливка с отбелнным поверхностным слоем						
	[8]	H 35 x 26 x 26					050 109 309 050 109 309 A 050 109 309 H 050 109 309 J	<b>50 006 417</b>
<b>66</b>	<b>81</b>							
<b>AGU</b>	08.1997 → 12.2010	B	(LA)	4	1781 cm <sup>3</sup> 5V	110 kW (150 PS) 9,5	86,40 mm	
<b>ARZ</b>	08.1997 → 12.2010	B	(LA)	4	1781 cm <sup>3</sup> 5V	110 kW (150 PS) 9,5	86,40 mm	
99 933 6..								
Fortsetzung nächste Seite / continued on next page / suite page suivante / continuación página próxima / Продолжение на следующей странице								

					Reference	Item No.
	IN [2] 27,0 x 6 x 105,1	S - -	- 45° - VS -	22 - III	058 109 601 C 058 109 601 P 058109601C	<b>33413</b>
	EX [2] 30,0 x 6 x 103,8	RA/S- Cr - Na	- 45° - VS -	22 - III	058 109 611 E	<b>33394</b> (1)
	EX [2] 30,0 x 6 x 103,9	RA/S- Cr -	- 45° - VS -	22 - III		<b>331108</b> (2)
	(1) OES specification					
	(2) IAM specification					
	[50] Ø 6 mm				036 109 651A	<b>MK-6H</b>
	IN/EX [4] 11,04 x 6 x 39,0	B1			058 103 415	<b>81-33121</b>
	IN/EX [4] 11,05 x 6 x 36,0	B1				<b>81-33111</b>
	IN/EX [4] 11,15 x 6 x 36,0	B1				<b>81-33118</b>
	EX [4] 11,04 x 6 x 39,0	G2				<b>81-33122</b>
	ES AS				058 109 021 B 058 109 022 B	<b>50 006 307</b> (3) <b>50 006 308</b> (3)
	(3) Schalenhartguss/chilled cast iron/pièce moulée trempée en surface/fundición en coquilla/Отливка с отбеленным поверхностным слоем					
	[8] H 24 x 24 x 24				058 109 309 B 058 109 309 F 058 109 309 J	<b>50 006 425</b> (4)
	[8] H 33,5 x 25,6 x 25,6				058 109 309 A 058 109 309 E 058 109 309 K	<b>50 006 426</b> (5)
	(4) Einlass/intake/admission/entrada/коллектора					
	(5) Auslass/Exhaust/sortie/salida/Выпуск					

**67**
**81**
**ARX**  
40 434 6..

 08.1997 → 12.2010 B (LA) 4 1781 cm<sup>3</sup> 5V 110 kW (150 PS) 9,5 86,40 mm

	IN [2] 27,0 x 6 x 105,1	S - -	- 45° - VS -	22 - III	058 109 601 C 058 109 601 P 058109601C	<b>33413</b>
	EX [2] 30,0 x 6 x 103,8	RA/S- Cr - Na	- 45° - VS -	22 - III	058 109 611 E	<b>33394</b> (1)
	EX [2] 30,0 x 6 x 103,9	RA/S- Cr -	- 45° - VS -	22 - III		<b>331108</b> (2)
	(1) OES specification					
	(2) IAM specification					
	[50] Ø 6 mm				036 109 651A	<b>MK-6H</b>
	IN/EX [4] 11,04 x 6 x 39,0	B1			058 103 415	<b>81-33121</b>
	IN/EX [4] 11,05 x 6 x 36,0	B1				<b>81-33111</b>
	IN/EX [4] 11,15 x 6 x 36,0	B1				<b>81-33118</b>
	EX [4] 11,04 x 6 x 39,0	G2				<b>81-33122</b>
	AS				058 109 022 B	<b>50 006 308</b> (3)
	(3) Schalenhartguss/chilled cast iron/pièce moulée trempée en surface/fundición en coquilla/Отливка с отбеленным поверхностным слоем					
	[8] H 24 x 24 x 24				058 109 309 B 058 109 309 F 058 109 309 J	<b>50 006 425</b> (4)
	[8] H 33,5 x 25,6 x 25,6				058 109 309 A 058 109 309 E 058 109 309 K	<b>50 006 426</b> (5)
	(4) Einlass/intake/admission/entrada/коллектора					
	(5) Auslass/Exhaust/sortie/salida/Выпуск					

**S**

					Reference	Item No.		
<b>68</b>	<b>81</b>							
<b>AUM</b>	08.1997 → 12.2010	B	(LA)	4	1781 cm <sup>3</sup> 5V	110 kW (150 PS) 9,5	86,40 mm	
<b>AUQ</b>	05.2001 → 01.2006	B	(A)	4	1781 cm <sup>3</sup> 5V	132 kW (180 PS) 9,5	86,40 mm	
40 434 6..								
	IN [2]	27,0 x 6 x 105,1	S	- -	- 45° - VS -	22 - III	058 109 601 C 058 109 601 P 058109601C	<b>33413</b>
	EX [2]	30,0 x 6 x 103,8	RA/S-	Cr - Na	- 45° - VS -	22 - III	058 109 611 E	<b>33394</b> (1)
	EX [2]	30,0 x 6 x 103,9	RA/S-	Cr -	- 45° - VS -	22 - III		<b>331108</b> (2)
	(1)	OES specification						
	(2)	IAM specification						
	[50]	∅ 6 mm					036 109 651A	<b>MK-6H</b>
	IN/EX [4]	11,04 x 6 x 39,0	B1				058 103 415	<b>81-33121</b>
	IN/EX [4]	11,05 x 6 x 36,0	B1					<b>81-33111</b>
	IN/EX [4]	11,15 x 6 x 36,0	B1					<b>81-33118</b>
	EX [4]	11,04 x 6 x 39,0	G2					<b>81-33122</b>
		AS ES					058 109 022 B 058 109 021 M	<b>50 006 308</b> (3) <b>50 007 581</b> (3)
	(3)	Schalenhartguss/chilled cast iron/pièce moulée trempée en surface/fundición en coquilla/Отливка с отбелсным поверхностным слоем						
	[8]	H 24 x 24 x 24					058 109 309 B 058 109 309 F 058 109 309 J	<b>50 006 425</b> (4)
	[8]	H 33,5 x 25,6 x 25,6					058 109 309 A 058 109 309 E 058 109 309 K	<b>50 006 426</b> (5)
	(4)	Einlass/intake/admission/entrada/коллектора						
	(5)	Auslass/Exhaust/sortie/salida/Выпуск						
<b>69</b>	<b>81</b>							
<b>AVU</b>	09.2000 → 12.2010	B	(NA)	4	1595 cm <sup>3</sup> 2V	75 kW (102 PS) 10,3	77,40 mm	
99 792 6..								
	IN [2]	39,5 x 6 x 94,0	S	- -	- 45° - -	22 - III	06B 109 601B 06B 109 601D 06B 109 601H	<b>331057</b>
	EX [2]	32,9 x 6 x 93,9	A/S	- -	- 45° - VS -	22 - III	06B 109 611 C 06B 109 611B	<b>331058</b>
	[50]	∅ 6 mm					036 109 651A	<b>MK-6H</b>
	IN/EX [4]	11,04 x 6 x 39,0	B1				058 103 415	<b>81-33121</b>
	IN/EX [4]	11,05 x 6 x 36,0	B1					<b>81-33111</b>
	IN/EX [4]	11,15 x 6 x 36,0	B1					<b>81-33118</b>
	IN/EX [4]	12,06 x 5.99 x 36,4	B1					<b>81-33113</b>
	EX [4]	11,04 x 6 x 39,0	G2					<b>81-33122</b>
							06B 109 101 G 06B 109 101 Q	<b>50 006 309</b> (1)
	(1)	Schalenhartguss/chilled cast iron/pièce moulée trempée en surface/fundición en coquilla/Отливка с отбелсным поверхностным слоем						
	[8]	H 12 x 34,5					022 109 423 A 022 109 423 D	<b>50 006 419</b>
	[4]						06B 109 417 C	<b>50 006 147</b>



					Reference	Item No.		
<b>70</b>		<b>81</b>						
<b>BFO</b>	09.2000 → 12.2010	B (NA)	4	1595 cm <sup>3</sup>	2V	75 kW (102 PS) 10,2	77,40 mm	
<b>CMXA Euro 5</b>	06.2004 → 06.2013	B (NA)	4	1595 cm <sup>3</sup>	2V	75 kW (102 PS) 10,5	77,40 mm	
99 792 6..								
	IN [2]	39,5 x 6 x 94,0	S - -	- 45° -	-	22 - III	06B 109 601B 06B 109 601D 06B 109 601H 06B 109 611 C 06B 109 611B	<b>331057</b>
	EX [2]	32,9 x 6 x 93,9	A/S - -	- 45° -	VS -	22 - III		<b>331058</b>
	[50]	Ø 6 mm					036 109 651A	<b>MK-6H</b>
	IN/EX [4]	12,06 x 5.99 x 36,4	B1					<b>81-33113</b>
	IN/EX [4]	12,08 x 5.98 x 36,5	B1					<b>81-33114</b>
	[8]	H 12 x 34,5					022 109 423 A 022 109 423 D	<b>50 006 419</b>
	[4]						06B 109 417 C	<b>50 006 147</b>
<b>71</b>		<b>81</b>						
<b>AWT</b>	12.2001 → 03.2008	B (A)	4	1781 cm <sup>3</sup>	5V	110 kW (150 PS) 9,5	86,40 mm	
40 434 6..								
	IN [2]	27,0 x 6 x 105,1	S - -	- 45° -	VS -	22 - III	058 109 601 C 058 109 601 P 058109601C	<b>33413</b>
	EX [2]	30,0 x 6 x 103,8	RA/S- Cr - Na	- 45° -	VS -	22 - III	058 109 611 E	<b>33394</b> (1)
	EX [2]	30,0 x 6 x 103,9	RA/S- Cr -	- 45° -	VS -	22 - III		<b>331108</b> (2)
	(1)	OES specification						
	(2)	IAM specification						
	[50]	Ø 6 mm					036 109 651A	<b>MK-6H</b>
	IN/EX [4]	11,04 x 6 x 39,0	B1					<b>81-33121</b>
	IN/EX [4]	11,05 x 6 x 36,0	B1				058 103 415	<b>81-33111</b>
	IN/EX [4]	11,15 x 6 x 36,0	B1					<b>81-33118</b>
	EX [4]	11,04 x 6 x 39,0	G2					<b>81-33122</b>
		ES					058 109 021 M	<b>50 007 581</b> (3)
	(3)	Schalenhartguss/chilled cast iron/pièce moulée trempée en surface/fundición en coquilla/Отливка с отбеленным поверхностным слоем						
	[8]	H 24 x 24 x 24					058 109 309 B 058 109 309 F 058 109 309 J	<b>50 006 425</b> (4)
	[8]	H 33,5 x 25,6 x 25,6					058 109 309 A 058 109 309 E 058 109 309 K	<b>50 006 426</b> (5)
	(4)	Einlass/intake/admission/entrada/коллектора						
	(5)	Auslass/Exhaust/sortie/salida/Выпуск						
<b>72</b>		<b>81</b>						
<b>BGU Euro 4</b>	06.2004 → 06.2013	B (NA)	4	1595 cm <sup>3</sup>	2V	75 kW (102 PS) 10,5	77,40 mm	
99 792 6..								
Fortsetzung nächste Seite / continued on next page / suite page suivante / continuación página próxima / Продолжение на следующей странице								

S

					Reference	Item No.
IN [2]	39,5 x 6 x 94,0	S - -	- 45° - -	22 - III	06B 109 601B 06B 109 601D 06B 109 601H	<b>331057</b>
EX [2]	32,9 x 6 x 93,9	A/S - -	- 45° - VS -	22 - III	06B 109 611 C 06B 109 611B	<b>331058</b>
[50]	Ø 6 mm				036 109 651A	<b>MK-6H</b>
IN/EX [4]	11,04 x 6 x 39,0	B1			058 103 415	<b>81-33121</b> <small>NEW</small>
IN/EX [4]	11,05 x 6 x 36,0	B1				<b>81-33111</b>
IN/EX [4]	11,15 x 6 x 36,0	B1				<b>81-33118</b> <small>NEW</small>
IN/EX [4]	12,06 x 5.99 x 36,4	B1				<b>81-33113</b>
IN/EX [4]	12,08 x 5.98 x 36,5	B1				<b>81-33114</b>
EX [4]	11,04 x 6 x 39,0	G2				<b>81-33122</b> <small>NEW</small>
[8]	H 12 x 34,5				022 109 423 A 022 109 423 D	<b>50 006 419</b>
[4]					06B 109 417 C	<b>50 006 147</b>

## 73 81

<b>BSE Euro 4/5</b>	06.2004 → 06.2013	B (NA)	4	1595 cm <sup>3</sup>	2V	75 kW	(102 PS)	10,5	77,40 mm
<b>BSF Euro 2</b>	06.2004 → 06.2013	B (NA)	4	1595 cm <sup>3</sup>	2V	75 kW	(102 PS)	10,5	77,40 mm
<b>CCSA Euro 4/5</b>	06.2004 → 06.2013	B (NA)	4	1595 cm <sup>3</sup>	2V	75 kW	(102 PS)	10,5	77,40 mm

99 792 6..

IN [2]	39,5 x 6 x 94,0	S - -	- 45° - -	22 - III	06B 109 601B 06B 109 601D 06B 109 601H	<b>331057</b>
EX [2]	32,9 x 6 x 93,9	A/S - -	- 45° - VS -	22 - III	06B 109 611 C 06B 109 611B	<b>331058</b>
[50]	Ø 6 mm				036 109 651A	<b>MK-6H</b>
IN/EX [4]	12,06 x 5.99 x 36,4	B1				<b>81-33113</b>
IN/EX [4]	12,08 x 5.98 x 36,5	B1				<b>81-33114</b>
IN/EX [1]	12,06 x 6 x 38,5	B1				<b>81-33125</b> <small>NEW</small>
[8]	H 12 x 34,5				022 109 423 A 022 109 423 D	<b>50 006 419</b>
[4]					06B 109 417 C	<b>50 006 147</b>

## 74 81

<b>AZV</b>	02.2004 → 05.2010	D (LA)	4	1968 cm <sup>3</sup>	4V	100 kW	(136 PS)	18	95,50 mm
<b>BKD</b>	02.2004 → 05.2015	D (LA)	4	1968 cm <sup>3</sup>	4V	103 kW	(140 PS)	18	95,50 mm

40 356 6.., 40 387 6..

IN [2]	29,2 x 6 x 87,8	S - -	- 45° - -	22 - III	03G 109 601B	<b>331121</b>
IN [2]	29,4 x 6 x 88,5	S - -	- 45° - -	22 - III	03G 109 601A	<b>331119</b>
EX [2]	25,5 x 6 x 87,5	RA/S- Cr -	- 45° - VS -	22 - III	03G 109 611D	<b>331122</b>
EX [1]	25,5 x 6 x 88,2	RA/S- -	- 45° - VS -	22 - III	03G 109 611B	<b>331120</b>
IN/EX [4]	10,06 x 6 x 42,0	B1				<b>81-33112</b>
	ES				03G 109 101 B 03G 109 101A 03G 109 102B	<b>50 007 575</b> (1)
	AS (1) (ST)					<b>50 007 576</b> (1)

Fortsetzung nächste Seite / continued on next page / suite page suivante / continuación página próxima / Продолжение на следующей странице

					Reference	Item No.
IN [4]					03G 109 411	<b>50 007 583</b> (2)
IN [4]					03G109411B	
					03G 109 411 A	<b>50 007 584</b> (3)
					03G109411C	
EX [4]					03G 109 412	<b>50 006 179</b> (2)
					03G109412B	
EX [4]					03G 109 412 A	<b>50 007 585</b> (3)
					03G109412C	
	(2) für Zylinder/for cylinder/pour cylindre/para cilindro/ля цилиндров 3+4					
	(3) für Zylinder/for cylinder/pour cylindre/para cilindro/для цилиндров 1-2					

## 75



## 81

<b>CBBB</b>	07.2008 → 05.2015	D	(LA)	4	1968 cm <sup>3</sup>	4V	125 kW	(170 PS)	16,5	95,50 mm
<b>CBDB</b>	05.2009 → 12.2017	D	(A)	4	1968 cm <sup>3</sup>	4V	103 kW	(140 PS)	16,5	95,50 mm
<b>CEGA</b>	04.2006 → 05.2015	D	(A)	4	1968 cm <sup>3</sup>	4V	125 kW	(170 PS)	16,5	95,50 mm
<b>CFFB</b>	01.2009 → 05.2015	D	(LA)	4	1968 cm <sup>3</sup>	4V	103 kW	(140 PS)	18,5	95,50 mm
<b>CFGB</b>	07.2008 → 05.2015	D	(LA)	4	1968 cm <sup>3</sup>	4V	125 kW	(170 PS)	16,5	95,50 mm
<b>CFHC</b>	02.2004 → 12.2017	D	(A)	4	1968 cm <sup>3</sup>	4V	103 kW	(140 PS)	16,5	95,50 mm
<b>CFHF</b>	11.2009 → 12.2017	D	(A)	4	1968 cm <sup>3</sup>	4V	81 kW	(110 PS)	16,5	95,50 mm
<b>CFJA</b>	11.2009 → 05.2015	D	(A)	4	1968 cm <sup>3</sup>	4V	125 kW	(170 PS)	16,5	95,50 mm
<b>CLCA</b>	11.2009 → 12.2017	D	(LA)	4	1968 cm <sup>3</sup>	4V	81 kW	(110 PS)	16,5	95,50 mm
<b>CLCB</b>	02.2004 → 12.2017	D	(A)	4	1968 cm <sup>3</sup>	4V	103 kW	(140 PS)	16,5	95,50 mm
<b>CLJA</b>	01.2009 → 05.2015	D	(LA)	4	1968 cm <sup>3</sup>	4V	103 kW	(140 PS)	18,5	95,50 mm

40 353 6..., 40 558 6..

IN [2]	28,1 x 6 x 99,3	S	-	-	-	45°	-	-	22	-	III	03L 109 601	<b>331131</b>
EX [2]	26,0 x 6 x 99,1	RA/S-	-	-	-	45°	-	VS	22	-	III	04L 109 601B	
												03L 109 611	<b>331132</b>
												04L 109 611B	
												04L 109 611C	
[50]	Ø 6 mm											036 109 651A	<b>MK-6H</b>
IN/EX [4]	10,06 x 6 x 42,0	B1											<b>81-33112</b>
	ES											03L 109 021	<b>50 007 020</b> <small>NEW</small> (1)
	AS											03L 109 021 D	
												03L 109 021 E	
												03L 109 022	<b>50 007 022</b> <small>NEW</small> (1)
												03L 109 022 D	
	(1) Schalenhartguss/chilled cast iron/pièce moulée trempée en surface/fundición en coquilla/Отливка с отбеленным поверхностным слоем												
[8]	H 12 x 32,5											03L 109 521	<b>50 006 490</b>
												03L 109 521 A	
[4]												059 109 417 A	<b>50 006 171</b>
												059 109 417 B	
												059 109 417 C	
												059 109 417 F	
												059 109 417 G	
												059109417J	

## 76



## 81

<b>BSS</b>	10.2005 → 03.2008	D	(LA)	4	1968 cm <sup>3</sup>	2V	103 kW	(140 PS)	18,5:1	95,50 mm
------------	-------------------	---	------	---	----------------------	----	--------	----------	--------	----------

40 408 6..., 40 409 6..

IN [2]	36,0 x 7 x 89,5	S	-	-	-	45°	-	-	22	-	III	038 109 601 E	<b>331123</b>
EX [2]	31,5 x 7 x 89,0	RA/S-	-	-	-	45°	-	VS	22	-	III	038 109 611 E	<b>331124</b>
[50]	Ø 7 mm											021 109 651	<b>MK-7H</b>

Fortsetzung nächste Seite / continued on next page / suite page suivante / continuación página próxima / Продолжение на следующей странице

					Reference	Item No.
	IN/EX [4] 12,08/15 x 7 x 36,5	B1			037 103 415 037 103 419 B	<b>81-33103</b>
	IN/EX [4] 12,25/15 x 7 x 36,5	B1				<b>81-33104</b>
	(1) (ST)				038 109 101 AH	<b>50 006 342</b> (1)
	[1]  (2) Kipphebeleinheit - nicht voreingestellt! rocker shaft assembly - not preset! Unité culbuteur - n'est pas pré réglée! Unidad de balancines: no preajustada! Узел коромысла — без предварительной настройки!				038109527AF	<b>50 007 650</b> (2)
	- - G - S - - SB - -				038 103 351 D 03G 103 351 C 03G 103 351 D	<b>50 003 131</b>

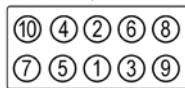

40 Nm  
60 Nm  
- 90° + 60 Nm  
90°  
90°

## 77 81

**BMM** 11.2005 → 05.2010 D (LA) 4 1968 cm<sup>3</sup> 2V 103 kW (140 PS) 18,5:1 95,50 mm  
40 408 6..., 40 409 6..

	IN [2] 36,0 x 7 x 89,5 EX [2] 31,5 x 7 x 89,0	S - - RA/S- -	- 45° - - - 45° - VS -	22 - III 22 - III	038 109 601 E 038 109 611 E	<b>331123</b> <b>331124</b>
	[50] Ø 7 mm				021 109 651	<b>MK-7H</b>
	IN/EX [4] 12,07 x 7 x 31,5	B1				<b>81-33115</b> <small>NEW</small>
	(1) (ST)				038 109 101 AH	<b>50 006 342</b> (1)
	[8] H 35 x 26 x 26				038 109 309 A 038 109 309 B 038 109 309 C	<b>50 006 418</b>
	[1]  (2) Kipphebeleinheit - nicht voreingestellt! rocker shaft assembly - not preset! Unité culbuteur - n'est pas pré réglée! Unidad de balancines: no preajustada! Узел коромысла — без предварительной настройки!				038109527AF	<b>50 007 650</b> (2)
	- - G - S - - SB - -				038 103 351 D 03G 103 351 C 03G 103 351 D	<b>50 003 131</b>

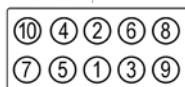

40 Nm  
60 Nm  
- 90° + 60 Nm  
90°  
90°

## 78 81

**BWW** 02.2006 → 03.2008 D (LA) 4 1968 cm<sup>3</sup> 2V 91 kW (124 PS) 95,50 mm  
40 408 6..., 40 409 6..

Fortsetzung nächste Seite / continued on next page / suite page suivante / continuación página próxima / Продолжение на следующей странице

					Reference	Item No.	
	IN [2] EX [2]	36,0 x 7 x 89,5 31,5 x 7 x 89,0	S - - RA/S- -	- 45° - - - 45° - VS -	22 - III 22 - III	038 109 601 E 038 109 611 E	<b>331123</b> <b>331124</b>
	[50]	Ø 7 mm				021 109 651	<b>MK-7H</b>
	IN/EX [4]	12,08/15 x 7 x 36,5	B1			037 103 415 037 103 419 B	<b>81-33103</b>
	IN/EX [4]	12,25/15 x 7 x 36,5	B1				<b>81-33104</b>
	(1) (ST)					038 109 101 AH	<b>50 006 342</b> (1)
	[1]  (2)	Kipphebeleinheit - nicht voreingestellt! rocker shaft assembly - not preset! Unité culbuteur - n'est pas pré réglée! Unidad de balancines: no preajustada! Узел коромысла — без предварительной настройки!				038109527AF	<b>50 007 650</b> (2)

**79** **81**  
**BMN** 04.2006 → 02.2013 D (LA) 4 1968 cm<sup>3</sup> 4V 125 kW (170 PS) 18,5 95,50 mm  
 40 387 6..

	IN [2] IN [2] EX [2] EX [1]	29,2 x 6 x 87,8 29,4 x 6 x 88,5 25,5 x 6 x 87,5 25,5 x 6 x 88,2	S - - S - - RA/S- Cr - RA/S- -	- 45° - - - 45° - - - 45° - VS - - 45° - VS -	22 - III 22 - III 22 - III 22 - III	03G 109 601B 03G 109 601A 03G 109 611D 03G 109 611B	<b>331121</b> <b>331119</b> <b>331122</b> <b>331120</b>
	IN/EX [4]	10,06 x 6 x 42,0	B1				<b>81-33112</b>
	(1) (ST)	ES AS				03G 109 101 B 03G 109 101A 03G 109 102 F	<b>50 007 575</b> (1) <b>50 007 578</b> (1)
	IN [4] IN [4] EX [4] EX [4]					03G 109 411 03G109411B 03G 109 411 A 03G109411C 03G 109 412 03G109412B 03G 109 412 A 03G109412C	<b>50 007 583</b> (2) <b>50 007 584</b> (3) <b>50 006 179</b> (2) <b>50 007 585</b> (3)
	(2)	für Zylinder/for cylinder/pour cylindre/para cilindro/ля цилиндров 3+4					
	(3)	für Zylinder/for cylinder/pour cylindre/para cilindro/для цилиндров 1-2					

**80** **81**  
**BMP** 03.2008 → 05.2010 D (LA) 4 1968 cm<sup>3</sup> 2V 103 kW (140 PS) 18,5 95,50 mm  
 40 408 6.., 40 409 6..

	IN [2] EX [2]	36,0 x 7 x 89,5 31,5 x 7 x 89,0	S - - RA/S- -	- 45° - - - 45° - VS -	22 - III 22 - III	038 109 601 E 038 109 611 E	<b>331123</b> <b>331124</b>
	[50]	Ø 7 mm				021 109 651	<b>MK-7H</b>
	IN/EX [4]	12,08/15 x 7 x 36,5	B1			037 103 415 037 103 419 B	<b>81-33103</b>
	IN/EX [4]	12,25/15 x 7 x 36,5	B1				<b>81-33104</b>

Fortsetzung nächste Seite / continued on next page / suite page suivante / continuación página próxima / Продолжение на следующей странице

					Reference	Item No.
	(1) (ST)				038 109 101 AH	<b>50 006 342</b> (1)
	[8] H 35 x 26 x 26				038 109 309 A 038 109 309 B 038 109 309 C	<b>50 006 418</b>
	[1]  (2) Kipphebeleinheit - nicht voreingestellt! rocker shaft assembly - not preset! Unité culbuteur - n'est pas pré-réglée! Unidad de balancines: no preajustada! Узел коромысла — без предварительной настройки!				038109527AF	<b>50 007 650</b> (2)
	- - G - S -	- SB - -			038 103 351 D 03G 103 351 C 03G 103 351 D	<b>50 003 131</b>
					40 Nm 60 Nm - 90° + 60 Nm 90° 90°	

## 81

<b>CFHA</b>	11.2009 → 12.2017	D (A)	4	1968 cm <sup>3</sup>	4V	81 kW	(110 PS)	16,5	95,50 mm
<b>CKFB Euro 6</b>	11.2012 →	D (LA)	4	1968 cm <sup>3</sup>	4V	105 kW	(143 PS)		95,50 mm
<b>CKFC Euro 5</b>	11.2012 →	D (LA)	4	1968 cm <sup>3</sup>	4V	110 kW	(150 PS)	16	95,50 mm
<b>CRMB Euro 6</b>	11.2012 →	D (LA)	4	1968 cm <sup>3</sup>	4V	110 kW	(150 PS)	16,2	95,50 mm
<b>CRVC Euro 4</b>	11.2012 →	D (LA)	4	1968 cm <sup>3</sup>	4V	105 kW	(143 PS)	16	95,50 mm
<b>CUNA Euro 6</b>	05.2013 →	D (LA)	4	1968 cm <sup>3</sup>	4V	135 kW	(184 PS)	15,8	95,50 mm
<b>CUPA</b>	05.2013 →	D (A)	4	1968 cm <sup>3</sup>	4V	135 kW	(184 PS)		95,50 mm

40 353 6.., 41 270 6.., 41 661 6..

	IN [2]	28,1 x 6 x 99,3	S - -	- 45° - -	22 - III	03L 109 601 04L 109 601B	<b>331131</b>
	EX [2]	26,0 x 6 x 99,1	RA/S- -	- 45° - VS -	22 - III	03L 109 611 04L 109 611B 04L 109 611C	<b>331132</b>
	[50]	∅ 6 mm				036 109 651A	<b>MK-6H</b>
	IN/EX [4]	10,06 x 6 x 42,0	B1				<b>81-33112</b>
	[8] H	12 x 32,5				03L 109 521 03L 109 521 A	<b>50 006 490</b>
	[4]					059 109 417 A 059 109 417 B 059 109 417 C 059 109 417 F 059 109 417 G 059109417J	<b>50 006 171</b>



					Reference	Item No.			
<b>82</b>		<b>81</b>							
<b>CRGA Euro 4</b>	03.2015 →	D (LA)	4	1968 cm <sup>3</sup>	4V	130 kW (177 PS)	15,5	95,50 mm	
<b>CRLB Euro 6</b>	03.2015 →	D (LA)	4	1968 cm <sup>3</sup>	4V	110 kW (150 PS)	16,2	95,50 mm	
<b>CUUA</b>	11.2009 → 12.2017	D (A)	4	1968 cm <sup>3</sup>	4V	81 kW (110 PS)		95,50 mm	
<b>CUUB</b>	05.2015 → 12.2017	D (A)	4	1968 cm <sup>3</sup>	4V	110 kW (150 PS)		95,50 mm	
<b>CYKA</b>	11.2012 →	D (LA)	4	1968 cm <sup>3</sup>	4V	110 kW (150 PS)	0	95,50 mm	
<b>DBGA Euro 5</b>	10.2016 →	D (LA)	4	1968 cm <sup>3</sup>	4V	110 kW (150 PS)	16,2	95,50 mm	
<b>DBGC Euro 5</b>	10.2016 →	D (A)	4	1968 cm <sup>3</sup>	4V	110 kW (150 PS)	16,2	95,50 mm	
<b>DCYA Euro 6</b>	11.2012 →	D (LA)	4	1968 cm <sup>3</sup>	4V	110 kW (150 PS)	16,2	95,50 mm	
<b>DFCA</b>	03.2015 →	D (A)	4	1968 cm <sup>3</sup>	4V	140 kW (190 PS)	15,5	95,50 mm	
<b>DFEA Euro 6</b>	03.2015 →	D (LA)	4	1968 cm <sup>3</sup>	4V	110 kW (150 PS)	16,2	95,50 mm	
<b>DFGA Euro 6</b>	03.2015 →	D (LA)	4	1968 cm <sup>3</sup>	4V	110 kW (150 PS)	16,2	95,50 mm	
<b>DFHA Euro 6</b>	03.2015 →	D (LA)	4	1968 cm <sup>3</sup>	4V	140 kW (190 PS)	15,5-16,2	95,50 mm	
<b>DFSA</b>	11.2009 → 12.2017	D (A)	4	1968 cm <sup>3</sup>	4V	81 kW (110 PS)		95,50 mm	
<b>DFSB</b>	05.2015 → 12.2017	D (A)	4	1968 cm <sup>3</sup>	4V	110 kW (150 PS)		95,50 mm	
41 270 6.., 41 647 6.., 41 936 6.., 41 937 6..									
	IN [2]	28,1 x 6 x 99,3	S - -	- 45° - -	-	22 - III	03L 109 601 04L 109 601B	<b>331131</b>	
	EX [2]	26,0 x 6 x 99,1	RA/S- -	- 45° - VS -	-	22 - III	03L 109 611 04L 109 611B 04L 109 611C	<b>331132</b>	
	[50]	Ø 6 mm					036 109 651A	<b>MK-6H</b>	
	IN/EX [4]	10,06 x 6 x 42,0	B1					<b>81-33112</b>	
<b>83</b>		<b>81</b>							
<b>DDAA</b>	03.2015 →	D (A)	4	1968 cm <sup>3</sup>	4V	140 kW (190 PS)	15,8	95,50 mm	
<b>DJGA Euro 6</b>	05.2013 →	D (LA)	4	1968 cm <sup>3</sup>	4V	135 kW (184 PS)	16,2	95,50 mm	
41 647 6..									
	IN [2]	28,1 x 6 x 99,3	S - -	- 45° - -	-	22 - III	03L 109 601 04L 109 601B	<b>331131</b>	
	EX [2]	26,0 x 6 x 99,1	RA/S- -	- 45° - VS -	-	22 - III	03L 109 611 04L 109 611B 04L 109 611C	<b>331132</b>	
	[50]	Ø 6 mm					036 109 651A	<b>MK-6H</b>	
<b>84</b>		<b>82,5</b>							
<b>AEG</b>	04.1999 → 05.2007	B (NA)	4	1984 cm <sup>3</sup>	2V	85 kW (116 PS)	10,5	92,80 mm	
	IN [2]	39,5 x 7 x 91,9	S - -	- 45° - -	-	22 - III	06A 109 601E 078 109 601A 078 109 601B 078 109 601E 078 109 601F 078109601B	<b>33403</b>	
	EX [2]	33,0 x 7 x 91,2	A/S - -	- 45° - VS -	-	22 - III	048 109 611B 078 109 611C	<b>33416</b>	
	[50]	Ø 7 mm					021 109 651	<b>MK-7H</b>	
	IN/EX [4]	12,08/15 x 7 x 36,5	B1				037 103 415 037 103 419 B	<b>81-33103</b>	
	IN/EX [4]	12,25/15 x 7 x 36,5	B1					<b>81-33104</b>	
							050 109 101A	<b>50 006 398</b> (1)	
Fortsetzung nächste Seite / continued on next page / suite page suivante / continuación página próxima / Продолжение на следующей странице									

S

					Reference	Item No.	
(1) Schalenhartguss/chilled cast iron/pièce moulée trempée en surface/fundición en coquilla/Отливка с отбелнным поверхностным слоем							
	[8]	H 35 x 26 x 26			050 109 309 050 109 309 A 050 109 309 H 050 109 309 J	<b>50 006 417</b>	
<b>85</b>		<b>82,5</b>					
APK	04.1999 → 05.2007	B (NA) 4	1984 cm <sup>3</sup> 2V	85 kW	(116 PS) 10,5	92,80 mm	
AQY	04.1999 → 05.2007	B (NA) 4	1984 cm <sup>3</sup> 2V	85 kW	(116 PS) 10,5	92,80 mm	
AZH	04.1999 → 05.2007	B (NA) 4	1984 cm <sup>3</sup> 2V	85 kW	(116 PS) 10,5	92,80 mm	
AZJ	04.1999 → 05.2007	B (NA) 4	1984 cm <sup>3</sup> 2V	85 kW	(116 PS) 10,5	92,80 mm	
AZM	12.2001 → 03.2008	B (NA) 4	1984 cm <sup>3</sup> 2V	85 kW	(115 PS) 10,5	92,80 mm	
	IN [2]	39,5 x 7 x 91,9	S - -	- 45° - -	22 - III	06A 109 601E 078 109 601A 078 109 601B 078 109 601E 078 109 601F 078109601B	<b>33403</b>
	EX [2]	33,0 x 7 x 91,2	A/S - -	- 45° - VS -	22 - III	048 109 611B 078 109 611C	<b>33416</b>
	[50]	∅ 7 mm				021 109 651	<b>MK-7H</b>
	IN/EX [4]	12,08/15 x 7 x 36,5	B1			037 103 415 037 103 419 B	<b>81-33103</b>
	IN/EX [4]	12,25/15 x 7 x 36,5	B1				<b>81-33104</b>
	[8]	H 35 x 26 x 26				050 109 309 050 109 309 A 050 109 309 H 050 109 309 J	<b>50 006 417</b>
<b>86</b>		<b>82,5</b>					
AZL	12.1999 → 03.2008	B (NA) 4	1984 cm <sup>3</sup> 2V	85 kW	(116 PS) 10,5	92,80 mm	
	IN [2]	39,5 x 7 x 91,9	S - -	- 45° - -	22 - III	06A 109 601E 078 109 601A 078 109 601B 078 109 601E 078 109 601F 078109601B	<b>33403</b>
	EX [2]	33,0 x 7 x 91,2	A/S - -	- 45° - VS -	22 - III	048 109 611B 078 109 611C	<b>33416</b>
	[50]	∅ 7 mm				021 109 651	<b>MK-7H</b>
	IN/EX [4]	12,08/15 x 7 x 36,5	B1			037 103 415 037 103 419 B	<b>81-33103</b>
	IN/EX [4]	12,25/15 x 7 x 36,5	B1				<b>81-33104</b>
<b>87</b>		<b>82,5</b>					
AMX	12.2001 → 03.2008	B (NA) 6	2771 cm <sup>3</sup> 5V	142 kW	(193 PS) 10,6	86,40 mm	
BBG	06.2002 → 03.2008	B (NA) 6	2771 cm <sup>3</sup> 5V	140 kW	(190 PS) 10,6	86,40 mm	
99 942 6..							
	IN [2]	27,0 x 6 x 105,1	S - -	- 45° - VS -	22 - III	058 109 601 C 058 109 601 P 058109601C	<b>33413</b>
	EX [2]	30,1 x 6 x 103,9	RA/S- Cr -	- 45° - VS -	22 - III	058 109 611 M 06B 109 611 D	<b>331107</b>
	[50]	∅ 6 mm				036 109 651A	<b>MK-6H</b>
Fortsetzung nächste Seite / continued on next page / suite page suivante / continuación página próxima / Продолжение на следующей странице							

					Reference	Item No.
	IN/EX [4] 11,04 x 6 x 39,0 IN/EX [4] 11,05 x 6 x 36,0 IN/EX [4] 11,15 x 6 x 36,0 EX [4] 11,04 x 6 x 39,0	B1 B1 B1 G2			058 103 415	<b>81-33121</b> <b>81-33111</b> <b>81-33118</b> <b>81-33122</b>
	[8] H 24 x 24 x 24  [8] H 33,5 x 25,6 x 25,6				058 109 309 B 058 109 309 F 058 109 309 J 058 109 309 A 058 109 309 E 058 109 309 K	<b>50 006 425</b> (1)  <b>50 006 426</b> (2)
	(1) Einlass/intake/admission/entrada/коллектора (2) Auslass/Exhaust/sortie/salida/Выпуск					

## 88

### 82,5

<b>BLR</b>	11.2004 → 10.2008	B (NA)	4	1984 cm <sup>3</sup>	4V	110 kW	(150 PS)	11,5	92,80 mm
<b>BLX</b>	11.2004 → 04.2009	B (NA)	4	1984 cm <sup>3</sup>	4V	110 kW	(150 PS)	11,5	92,80 mm
<b>BLY</b>	11.2004 → 04.2009	B (NA)	4	1984 cm <sup>3</sup>	4V	110 kW	(150 PS)	11,5	92,80 mm
<b>BVX</b>	11.2004 → 04.2009	B (NA)	4	1984 cm <sup>3</sup>	4V	110 kW	(150 PS)	11,5	92,80 mm
<b>BVY</b>	11.2004 → 10.2008	B (NA)	4	1984 cm <sup>3</sup>	4V	110 kW	(150 PS)	11,5	92,80 mm
<b>BVZ</b>	11.2004 → 10.2008	B (NA)	4	1984 cm <sup>3</sup>	4V	110 kW	(150 PS)	11,5	92,80 mm

	IN [2] 33,9 x 6 x 104,0	S - -	- 45° - -	22 - III	06D 109 601K 06E 109 601E 06E 109 601F	<b>331116</b>
	EX [2] 28,0 x 6 x 101,9	I/S - Cr -	- 45° - -	22 - III	06D 109 611K 06D 109 611L 06D 109 611T 06E 109 611D 06K 109 611	<b>331117</b> (1)
	EX [2] 28,0 x 6 x 102,0 (1) OES specification (2) IAM specification	RA/S- Cr -	- 45° - VS -	22 - III		<b>331144</b> (2)

	[50] Ø 6 mm				036 109 651A	<b>MK-6H</b>
--	-------------	--	--	--	--------------	--------------

	IN/EX [4] 11,04 x 6 x 39,0 IN/EX [4] 11,05 x 6 x 36,0 IN/EX [4] 11,15 x 6 x 36,0 EX [4] 11,04 x 6 x 39,0	B1 B1 B1 G2			058 103 415	<b>81-33121</b> <b>81-33111</b> <b>81-33118</b> <b>81-33122</b>
--	---	----------------------	--	--	-------------	--

	ES				06D 109 101 AL 06D 109 101 AP 06D 109 102 AK	<b>50 007 588</b> (3)
	AS (3) (ST)					<b>50 007 589</b> (3)

	[8] H 12 x 34,5				022 109 423 A 022 109 423 D	<b>50 006 419</b>
--	-----------------	--	--	--	--------------------------------	-------------------

	[8]				06E 109 417 F	<b>50 006 149</b>
--	-----	--	--	--	---------------	-------------------

## 89

### 82,5

<b>BWA</b>	10.2005 → 02.2013	B (LA)	4	1984 cm <sup>3</sup>	4V	147 kW	(200 PS)	10,3	92,80 mm
------------	-------------------	--------	---	----------------------	----	--------	----------	------	----------

	IN [2] 33,9 x 6 x 104,0	S - -	- 45° - VS -	22 - III	06D 109 601M 06J 106 601H 079 109 601B 079 109 601E	<b>331125</b>
	EX [2] 28,0 x 6 x 101,9	RA/S- Cr - Na	- 45° - VS -	22 - III	06D 109 611 P 06D 109 611H 06J 109 611D	<b>331126</b>

Fortsetzung nächste Seite / continued on next page / suite page suivante / continuación página próxima / Продолжение на следующей странице

					Reference	Item No.
[50]	Ø 6 mm				036 109 651A	<b>MK-6H</b>
IN/EX [4] IN/EX [4] IN/EX [4] EX [4]	11,04 x 6 x 39,0 11,05 x 6 x 36,0 11,15 x 6 x 36,0 11,04 x 6 x 39,0	B1 B1 B1 G2			058 103 415	<b>81-33121</b> <small>NEW</small> <b>81-33111</b> <b>81-33118</b> <small>NEW</small> <b>81-33122</b> <small>NEW</small>
	ES AS (1) (ST)				06F 109 101 B 06F 109 101J 06F 109 102 B	<b>50 007 586</b> (1) <b>50 007 587</b> (1)
[8]	H 12 x 34,5				022 109 423 A 022 109 423 D	<b>50 006 419</b>
[8]					06E 109 417 F	<b>50 006 149</b>

## 90 82,5

**CCZA** 10.2005 → 05.2015 B (LA) 4 1984 cm<sup>3</sup> 4V 147 kW (200 PS) 9,6 92,80 mm  
40 247 6..., 41 198 6..

IN [2]	33,9 x 6 x 104,0	S - -	- 45° - VS -	22 - III	06D 109 601M 06J 106 601H 079 109 601B 079 109 601E	<b>331125</b>
EX [2]	28,0 x 6 x 101,9	RA/S- Cr - Na	- 45° - VS -	22 - III	06D 109 611 P 06D 109 611H 06J 109 611D	<b>331126</b>
[50]	Ø 6 mm				036 109 651A	<b>MK-6H</b>
IN/EX [4] IN/EX [4] IN/EX [4] EX [4]	11,04 x 6 x 39,0 11,05 x 6 x 36,0 11,15 x 6 x 36,0 11,04 x 6 x 39,0	B1 B1 B1 G2			058 103 415	<b>81-33121</b> <small>NEW</small> <b>81-33111</b> <b>81-33118</b> <small>NEW</small> <b>81-33122</b> <small>NEW</small>
	ES AS (1) Lagerbock bearing bracket chevalet support pedestal de cojinete кронштейн подшипника				06H103144J 06H103144K 06H109021K 06H 109 022 AH 06H 109 022 BC	<b>50 007 669</b> (1) <b>50 007 673</b> <b>50 007 712</b>
[4]					06E 109 417 06E 109 417 E	<b>50 006 148</b>

## 91 82,5

**BZB** 06.2007 → 05.2015 B (A) 4 1798 cm<sup>3</sup> 4V 118 kW (160 PS) 9,6 84,20 mm  
40 251 6..

IN [2]	33,9 x 6 x 104,0	S - -	- 45° - VS -	22 - III	06D 109 601M 06J 106 601H 079 109 601B 079 109 601E	<b>331125</b>
EX [2]	28,0 x 6 x 101,9	RA/S- Cr - Na	- 45° - VS -	22 - III	06D 109 611 P 06D 109 611H 06J 109 611D	<b>331126</b>
[50]	Ø 6 mm				036 109 651A	<b>MK-6H</b>

Fortsetzung nächste Seite / continued on next page / suite page suivante / continuación página próxima / Продолжение на следующей странице

					Reference	Item No.
	IN/EX [4] 11,04 x 6 x 39,0 IN/EX [4] 11,05 x 6 x 36,0 IN/EX [4] 11,15 x 6 x 36,0 EX [4] 11,04 x 6 x 39,0	B1 B1 B1 G2			058 103 415	<b>81-33121</b> <b>81-33111</b> <b>81-33118</b> <b>81-33122</b>
	ES AS  (1) Lagerbock bearing bracket chevalet support pedestal de cojinete кронштин подшпника				06H109021J 06H109022BA 06H103144J 06H103144K	<b>50 007 634</b> <b>50 007 635</b> <b>50 007 669</b> (1)
	[4]				06E 109 417 06E 109 417 E	<b>50 006 148</b>

**92** **82,5**  
**CDA** 06.2007 → 12.2017 B (A) 4 1798 cm<sup>3</sup> 4V 118 kW (160 PS) 9,6 84,10 mm  
 41 197 6..

	IN [2] 33,9 x 6 x 104,0  EX [2] 28,0 x 6 x 101,9  EX [2] 28,0 x 6 x 102,0 (1) OES specification (2) IAM specification	S - - I/S - Cr - RA/S- Cr -	- 45° - VS - - 45° - - - 45° - VS -	22 - III 22 - III 22 - III	06D 109 601M 06J 106 601H 079 109 601B 079 109 601E 06D 109 611K 06D 109 611L 06D 109 611T 06E 109 611D 06K 109 611	<b>331125</b>  <b>331117</b> (1)  <b>331144</b> (2)
	[50] Ø 6 mm				036 109 651A	<b>MK-6H</b>
	IN/EX [4] 11,04 x 6 x 39,0 IN/EX [4] 11,05 x 6 x 36,0 IN/EX [4] 11,15 x 6 x 36,0 EX [4] 11,04 x 6 x 39,0	B1 B1 B1 G2			058 103 415	<b>81-33121</b> <b>81-33111</b> <b>81-33118</b> <b>81-33122</b>
	ES AS  (3) Lagerbock bearing bracket chevalet support pedestal de cojinete кронштин подшпника				06H109021J 06H109022BA 06H103144J 06H103144K	<b>50 007 634</b> <b>50 007 635</b> <b>50 007 669</b> (3)
	[8] H 12 x 34,5				022 109 423 A 022 109 423 D	<b>50 006 419</b>
	[4]				06E 109 417 06E 109 417 E	<b>50 006 148</b>

**93** **82,5**  
**CDAB** 03.2009 → 12.2017 B (LA) 4 1798 cm<sup>3</sup> 4V 112 kW (152 PS) 9,6 84,10 mm  
 41 197 6..

Fortsetzung nächste Seite / continued on next page / suite page suivante / continuación página próxima / Продолжение на следующей странице						
--	--	--	--	--	--	--

					Reference	Item No.
IN [2]	33,9 x 6 x 104,0	S - -	- 45° - VS -	22 - III	06D 109 601M 06J 106 601H 079 109 601B 079 109 601E	<b>331125</b>
EX [2]	28,0 x 6 x 101,9	I/S - Cr -	- 45° - -	22 - III	06D 109 611K 06D 109 611L 06D 109 611T 06E 109 611D 06K 109 611	<b>331117</b> (1)
EX [2] (1) OES specification (2) IAM specification	28,0 x 6 x 102,0	RA/S- Cr -	- 45° - VS -	22 - III		<b>331144</b> (2)
[50]	∅ 6 mm				036 109 651A	<b>MK-6H</b>
IN/EX [4] IN/EX [4] IN/EX [4] EX [4]	11,04 x 6 x 39,0 11,05 x 6 x 36,0 11,15 x 6 x 36,0 11,04 x 6 x 39,0	B1 B1 B1 G2			058 103 415	<b>81-33121</b> <small>NEW</small> <b>81-33111</b> <b>81-33118</b> <small>NEW</small> <b>81-33122</b> <small>NEW</small>
	ES AS  (3) Lagerbock bearing bracket chevalet support pedestal de cojinete кронштѣйн подшпника				06H109021J 06H109022BA 06H103144J 06H103144K	<b>50 007 634</b> <small>NEW</small> <b>50 007 635</b> <small>NEW</small> <b>50 007 669</b> (3)
[4]					06E 109 417 06E 109 417 E	<b>50 006 148</b>

## 94 82,5

**CHHB Euro 6** 11.2012 → B (LA) 4 1984 cm<sup>3</sup> 4V 162 kW (220 PS) 9,6 92,80 mm  
41 501 6..

IN [2]	33,8 x 6 x 104,0	S - -	- 45° - -	22 - III	06K 109 601 06L 109 601	<b>331162</b> <small>NEW</small>
EX [2]	28,0 x 5,9 x 101,8	RA/S- Cr - Na	- 45° - VS -	22 - III	06E 109 611K 06K 109 611A 06K 109 611E 079 109 611D 079 109 611F 079 109 611G	<b>331160</b> <small>NEW</small>
EX [2]	28,0 x 6 x 101,9	I/S - Cr -	- 45° - -	22 - III	06D 109 611K 06D 109 611L 06D 109 611T 06E 109 611D 06K 109 611	<b>331117</b> (1)
EX [2] (1) OES specification (2) IAM specification	28,0 x 6 x 102,0	RA/S- Cr -	- 45° - VS -	22 - III		<b>331144</b> (2)
[50]	∅ 6 mm				036 109 651A	<b>MK-6H</b>
IN/EX [4] IN/EX [4] IN/EX [4] EX [4]	11,04 x 6 x 39,0 11,05 x 6 x 36,0 11,15 x 6 x 36,0 11,04 x 6 x 39,0	B1 B1 B1 G2			058 103 415	<b>81-33121</b> <small>NEW</small> <b>81-33111</b> <b>81-33118</b> <small>NEW</small> <b>81-33122</b> <small>NEW</small>

Fortsetzung nächste Seite / continued on next page / suite page suivante / continuación página próxima / Продолжение на следующей странице



					Reference	Item No.
	(3) Lagerbock bearing bracket chevalet support pedestal de cojinete кронштейн подшипника				06L103144F 06L103144H	<b>50 007 670</b> (3)
	[4]				06E109417AA 06E109417N	<b>50 007 657</b>

## 95 82,5

<b>CJSA Euro 6</b>	11.2012 →	B (LA)	4	1798 cm <sup>3</sup>	4V	132 kW	(180 PS)	9,6	84,10 mm
<b>CJSB Euro 6</b>	11.2012 →	B (LA)	4	1798 cm <sup>3</sup>	4V	132 kW	(180 PS)	9,6	84,10 mm

40 760 6.., 41 509 6..

	IN [2]	33,8 x 6 x 104,0	S - -	- 45° - -	22 - III	06K 109 601 06L 109 601	<b>331162</b>
	EX [2]	28,0 x 6 x 101,9	I/S - Cr -	- 45° - -	22 - III	06D 109 611K 06D 109 611L 06D 109 611T 06E 109 611D 06K 109 611	<b>331117</b> (1)
	EX [2]	28,0 x 6 x 102,0 (1) OES specification (2) IAM specification	RA/S- Cr -	- 45° - VS -	22 - III		<b>331144</b> (2)
	[50]	∅ 6 mm				036 109 651A	<b>MK-6H</b>
	IN/EX [4]	11,04 x 6 x 39,0	B1				<b>81-33121</b>
	IN/EX [4]	11,05 x 6 x 36,0	B1			058 103 415	<b>81-33111</b>
	IN/EX [4]	11,15 x 6 x 36,0	B1				<b>81-33118</b>
	EX [4]	11,04 x 6 x 39,0	G2				<b>81-33122</b>
	(3) Lagerbock bearing bracket chevalet support pedestal de cojinete кронштейн подшипника					06L103144F 06L103144H	<b>50 007 670</b> (3)
	[8]	H 12 x 34,5				022 109 423 A 022 109 423 D	<b>50 006 419</b>
	[4]					06E109417AA 06E109417N	<b>50 007 657</b>

## 96 82,5

<b>CJSC Euro 6</b>	03.2015 →	B (LA)	4	1798 cm <sup>3</sup>	4V	132 kW	(180 PS)	9,6	84,10 mm
--------------------	-----------	--------	---	----------------------	----	--------	----------	-----	----------

41 509 6..

	IN [2]	33,8 x 6 x 104,0	S - -	- 45° - -	22 - III	06K 109 601 06L 109 601	<b>331162</b>
	EX [2]	28,0 x 6 x 101,9	I/S - Cr -	- 45° - -	22 - III	06D 109 611K 06D 109 611L 06D 109 611T 06E 109 611D 06K 109 611	<b>331117</b> (1)
	EX [2]	28,0 x 6 x 102,0 (1) OES specification (2) IAM specification	RA/S- Cr -	- 45° - VS -	22 - III		<b>331144</b> (2)

Fortsetzung nächste Seite / continued on next page / suite page suivante / continuación página próxima / Продолжение на следующей странице

					Reference	Item No.
[50]	Ø 6 mm				036 109 651A	<b>MK-6H</b>
IN/EX [4]	11,04 x 6 x 39,0	B1			058 103 415	<b>81-33121</b> <small>NEW</small>
IN/EX [4]	11,05 x 6 x 36,0	B1				<b>81-33111</b>
IN/EX [4]	11,15 x 6 x 36,0	B1				<b>81-33118</b> <small>NEW</small>
EX [4]	11,04 x 6 x 39,0	G2				<b>81-33122</b> <small>NEW</small>
	(3) Lagerbock bearing bracket chevalet support pedestal de cojinete кронштјин подшпника				06L103144F 06L103144H	<b>50 007 670</b> (3)

## 97 82,5

<b>CJXA</b>	03.2015 →	B (A)	4	1984 cm <sup>3</sup>	4V	206 kW	(280 PS)	92,80 mm
<b>DKTB Euro 6</b>	02.2017 →	B (LA)	4	1984 cm <sup>3</sup>	4V	180 kW	(245 PS)	92,80 mm

41 192 6..., 41 533 6..

IN [2]	33,8 x 6 x 104,0	S - -	- 45° - -	22 - III	06K 109 601 06L 109 601	<b>331162</b> <small>NEW</small>
EX [2]	28,0 x 5,9 x 101,8	RA/S- Cr - Na	- 45° - VS -	22 - III	06E 109 611K 06K 109 611A 06K 109 611E 079 109 611D 079 109 611F 079 109 611G	<b>331160</b> <small>NEW</small>
[50]	Ø 6 mm				036 109 651A	<b>MK-6H</b>

## 98 82,5

<b>DLBA</b>	02.2017 →	B (A)	4	1984 cm <sup>3</sup>	4V	180 kW	(245 PS)	92,80 mm
<b>DNUA</b>	03.2015 →	B (LA)	4	1984 cm <sup>3</sup>	4V	200 kW	(272 PS)	92,80 mm

41 192 6..., 41 533 6..

IN [2]	33,8 x 6 x 104,0	S - -	- 45° - -	22 - III	06K 109 601 06L 109 601	<b>331162</b> <small>NEW</small>
EX [2]	28,0 x 5,9 x 101,8	RA/S- Cr - Na	- 45° - VS -	22 - III	06E 109 611K 06K 109 611A 06K 109 611E 079 109 611D 079 109 611F 079 109 611G	<b>331160</b> <small>NEW</small>
[50]	Ø 6 mm				036 109 651A	<b>MK-6H</b>
	(1) Lagerbock bearing bracket chevalet support pedestal de cojinete кронштјин подшпника				06L103144F 06L103144H	<b>50 007 670</b> (1)

## 99 82,5

<b>CHHA</b>	05.2015 →	B (LA)	4	1984 cm <sup>3</sup>	4V	169 kW	(230 PS) 9,6	92,80 mm
-------------	-----------	--------	---	----------------------	----	--------	--------------	----------

41 501 6..

Fortsetzung nächste Seite / continued on next page / suite page suivante / continuación página próxima / Продолжение на следующей странице

					Reference	Item No.	
	IN [2] EX [2]	33,8 x 6 x 104,0 28,0 x 5,9 x 101,8	S - - RA/S- Cr - Na	- 45° - - - 45° - VS -	22 - III 22 - III	06K 109 601 06L 109 601 06E 109 611K 06K 109 611A 06K 109 611E 079 109 611D 079 109 611F 079 109 611G	<b>331162</b> <small>NEW</small> <b>331160</b> <small>NEW</small>
	[50]	∅ 6 mm				036 109 651A	<b>MK-6H</b>
	(1)	Lagerbock bearing bracket chevalet support pedestal de cojinete кронштейн подшпника				06L103144F 06L103144H	<b>50 007 670</b> (1)
	[4]					06E109417AA 06E109417N	<b>50 007 657</b>

## 100 82,5

<b>CZPA Euro 6</b>	10.2016 →	B (A)	4	1984 cm <sup>3</sup>	4V	132 kW	(180 PS)	11,65	92,80 mm
<b>DKZA Euro 6</b>	02.2017 →	B (LA)	4	1984 cm <sup>3</sup>	4V	140 kW	(190 PS)		92,80 mm

41 192 6..

	(1)	Lagerbock bearing bracket chevalet support pedestal de cojinete кронштейн подшпника				06L103144F 06L103144H	<b>50 007 670</b> (1)
--	-----	---	--	--	--	--------------------------	-----------------------

## 101 82,5

<b>CEAA</b>		B (A)	4	1798 cm <sup>3</sup>	4V	118 kW	(160 PS)	0	84,20 mm
<b>CGMA</b>		B (A)	4	1984 cm <sup>3</sup>	4V	147 kW	(200 PS)	0	92,80 mm







	IN [2] EX [2]	33,9 x 6 x 104,0 28,0 x 6 x 101,9	S - - RA/S- Cr - Na	- 45° - VS - - 45° - VS -	22 - III 22 - III	06D 109 601M 06J 106 601H 079 109 601B 079 109 601E 06D 109 611 P 06D 109 611H 06J 109 611D	<b>331125</b> <b>331126</b>
	[50]	∅ 6 mm				036 109 651A	<b>MK-6H</b>

## 102 89

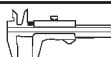
<b>CDVA Euro 5</b>	11.2008 → 05.2015	B (NA)	6	3597 cm <sup>3</sup>	4V	191 kW	(260 PS)	11,4	96,40 mm
--------------------	-------------------	--------	---	----------------------	----	--------	----------	------	----------

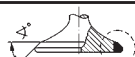
	IN [2] IN [2] EX [2] EX [2]	33,2 x 6 x 102,4 33,2 x 6 x 136,3 30,2 x 6 x 102,2 30,2 x 6 x 136,1	S - - S - - RA/S- - RA/S- -	- 45° - - - 45° - - - 45° - VS - - 45° - VS -	22 - III 22 - III 22 - III 22 - III	022 109 601 AJ 022 109 601 G 022 109 601 AK 022 109 601 H 022 109 611 AA 022 109 611 N 03H 109 611 D 022 109 611 AB 022 109 611 M 022 109 611 P 03H 109 611 E	<b>331127</b> <b>331128</b> <b>331129</b> <b>331130</b>
--	--------------------------------------	--	--------------------------------------	--	--	---	--

Fortsetzung nächste Seite / continued on next page / suite page suivante / continuación página próxima / Продолжение на следующей странице

					Reference	Item No.
 [50]	Ø 6 mm				036 109 651A	<b>MK-6H</b>
 IN [4] EX [4]	10,06 x 6 x 44,0 10,06 x 6 x 65,0	B1 B1				<b>81-33119</b> <small>NEW</small> <b>81-33120</b> <small>NEW</small>
 [4]					022 109 417 C 022 109 417 E	<b>50 006 144</b>

		Cyl.		mm	cm <sup>3</sup>		Comp. Ratio $\epsilon$	kW	PS	Pos
113 (34)	B	4		77 x 64	1192	2	7,7:3	22-25	30-34	117
122	B (NA)	4		77 x 64	1192	2	7,5:1	18-25	25-34	121
122/2	B	4		77 x 64	1192	2	7,5:1	25	34	121
1C	D (A)	4		76,5 x 86,4	1588	2	23	51	69	110
1E	B (NA)	6		76,5 x 86,4	2383	2	8,1	69-70	94-95	48
1F	B (NA)	4		81 x 77,4	1595	2	9	55	75	217
1G	D (A)	6		76,5 x 86,4	2384	2	23	68	93	111
1H	B (K)	4		81 x 86,4	1781	2	8	118	160	218
1P	B (NA)	4		81 x 86,4	1781	2	9	72	98	219
1S	D (NA)	6		76,5 x 86,4	2383	2	23,5	51	70	112
1V	D (A)	4		76,5 x 86,4	1589	2	23	44	60	114
1W	D (NA)	4		75 x 79,1	1398	2	22,5	35	48	44
1X	D (NA)	4		79,5 x 95,5	1896	2	22,5	44-45	60-61	135
1Y	D (NA)	4		79,5 x 95,5	1896	2	22,5	47-50	64-68	134
1Z	D (A)	4		79,5 x 95,5	1896	2	19,5	66	90	138
2E	B (NA)	4		82,5 x 92,8	1984	2	10,5	85	115	297
2G	B (NA)	4		75 x 72	1272	2	9	40	54	29
2H	B (NA)	4		81 x 86,4	1781	2	9	72	98	220
2L	D (NA)	4		92 x 92	2446	2	22	58-61	79-83	391
311 (1.6L)	B	4		85,5 x 69	1584	2	7,5:1	40	54	376
3F	B (NA)	4		75 x 72	1272	2	10	55-57	75-78	29
4.236	D (NA)	4		98,43 x 127	3866	2	16:1	55-65	75-88	401
6 BTAA Euro 2	D (LA)	6		102 x 120	5883	2	17-17,6	94-173	124-235	402
6 CT 8.3 Euro 2	D (A)	6		114 x 135	8270	2	17,3:1	154-160	209-218	405
6 CTAA 8.3	D (LA)	6		114 x 135	8268	2	17,5:1	213-235	290-320	406
682	D (NA)	4		76,5 x 80	1471	2	23,5:1	33	45	99
685	D (NA)	4		76,5 x 86,4	1588	2	23:1	36	49	99
686	D (NA)	4		76,5 x 86,4	1588	2	23:1	45	61	99
68A	D (A)	4		76,5 x 86,4	1588	2	23:1	45	61	99
68C	D (A)	4		76,5 x 86,4	1588	2	23:1	50	68	99
68D	D	4		76,5 x 86,4	1588	2	23:1	36	48	113
9A	B (NA)	4		82,5 x 92,8	1984	4	10,8	100	136	296
AAA	B (NA)	6		81 x 90,3	2792	2	10	120-128	163-174	225
AAB	D (NA)	5		79,5 x 95,5	2370	2	23	57	78	136
AAC	B (NA)	4		81 x 95,5	1968	2	8,5	62	84	221
AAF	B (NA)	5		81 x 95,5	2461	2	8,5	80-81	108-110	219
AAK	B (NA)	4		75 x 59	1043	2	9,5	33	45	38
AAM	B (NA)	4		81 x 86,4	1781	2	9	55	75	222
AAU	B (NA)	4		75 x 59	1043	2	10	33	45	39
AAV	B (NA)	4		75 x 72	1272	2	9,2	40	55	40
AAZ	D (A)	4		79,5 x 95,5	1896	2	22,5	55	75	137
AB	B (NA)	4		77 x 69	1285	2	7,5	31-32	44	120
ABD	B (NA)	4		75 x 78,7	1390	2	9,2	40-44	54-60	41
ABF	B (NA)	4		82,5 x 92,8	1984	4	10,4	110	150	298
ABL	D (A)	4		79,5 x 95,5	1896	2	22,5	50	68	139
ABN	B (NA)	4		81 x 77,4	1595	2	9,1	54-55	73-75	199
ABS	B (NA)	4		81 x 86,4	1781	2	10	63-66	86-90	226
ABU	B (NA)	4		76,5 x 86,9	1598	2	9,3	55	75	50
ABV	B (NA)	6		82 x 90,3	2861	2	10	135-140	184-190	294
AC	B (NA)	4		77 x 69	1285	2	7,3:1	29	39	118
ACC	B (NA)	4		81 x 86,4	1781	2	10	66-67	90-91	229
ACK	B (NA)	6		82,5 x 86,4	2771	5	10,6	142	193	302
ACL	D (A)	6		76,5 x 86,4	2384	2	22	70	95	115
ACM	B (NA)	4		75 x 59	1043	2	10	33	45	29
ACT	D (NA)	6		76,5 x 86,4	2383	2	23	51	70	112
ACU	B (NA)	5		81 x 95,5	2461	2	8,5	80-81	108-110	219
ACV	D (LA)	5		81 x 95,5	2461	2	19,5	75	102	259
ACX	B (NA)	4		82,5 x 92,8	1984	2	10,4:1	78	106	297
AD	B (NA)	4		85,5 x 69	1584	2	7,5	35-48	48-50	378
ADC	B (NA)	4		82,5 x 92,8	1984	2	10,4:1	81-85	110-116	299
ADD	B (NA)	4		81 x 86,4	1781	2	10	63-75	86-102	228
ADE	D (A)	4		79,5 x 95,5	1896	2	22,5:1	56	76	141
ADG	D (NA)	4		79,5 x 95,5	1896	2	22,5:1	43	58	142
ADP	B (NA)	4		81 x 77,4	1595	2	10,3	74	101	235
ADR	B (NA)	4		81 x 86,4	1781	5	10,3	92	125	237
ADX	B (NA)	4		76,5 x 70,5	1296	2	10	40	55	51
ADY	B (NA)	4		82,5 x 92,8	1984	2	10,4	85	115	297
ADZ	B (NA)	4		81 x 86,4	1781	2	9	63-66	86-90	227
AEA	B (NA)	4		76,5 x 86,9	1598	2	9,8	55	75	52



Cyl.	mm	cm <sup>3</sup>	Comp. Ratio $\epsilon$	kW	PS	Pos		
AEB	B (A) 4	81 x 86,4	1781	5	9,5	110-112	150-152	239
AEE	B (NA) 4	76,5 x 86,9	1598	2	9,8	55	75	53
AEF	D (NA) 4	79,5 x 95,5	1896	2	22,5	47	64	144
AEG	B (NA) 4	82,5 x 92,8	1984	2	10,5	85	115	304
AEH	B (NA) 4	81 x 77,4	1595	2	10,3	74	100	235
AEK	B (NA) 4	81 x 77,4	1595	2	10,3	74	101	232
AEN	B (NA) 5	81 x 95,5	2461	2	10	81	110	219
AEP	B (NA) 4	82,5 x 92,8	1984	2	10,4	79	107	300
AER	B (NA) 4	67,1 x 70,6	999	2	10,5	37	50	1
AES	B (NA) 6	81 x 90,3	2792	2	10	103	140	233
AET	B (NA) 5	81 x 95,5	2461	2	8,5	81-85	110-115	236
AEU	B (NA) 5	81 x 95,5	2461	2	10	81	110	223
AEV	B (NA) 4	75 x 59	1043	2	10	33	45	42
AEX	B (NA) 4	76,5 x 75,6	1390	2	10,2	40-44	54-60	49
AEY	D (NA) 4	79,5 x 95,5	1896	2	19,5	47-48	64-65	145
AF	B (NA) 4	85,5 x 69	1584	2		33-37	46-50	377
AFB	D (LA) 6	78,3 x 86,4	2496	4	19,5	110	150	122
AFD	D (A) 4	79,5 x 95,5	1896	2	22,5:1	58	79	143
AFH	B (NA) 4	76,5 x 75,6	1390	4	10,5	74	100	55
AFK	B (NA) 4	76,5 x 75,6	1390	4	10,5	74	101	58
AFN	D (LA) 4	79,5 x 95,5	1896	2	19,5	81	110	140
AFT	B (NA) 4	81 x 77,4	1595	2	10,5	74	101	234
AFY	B (NA) 4	81 x 86,4	1781	5	10	85	115	240
AGD	D (NA) 4	79,5 x 95,5	1896	2	19,5	47	64	145
AGE	B (NA) 6	82,5 x 86,4	2771	5	10,6	132	180	302
AGG	B (NA) 4	82,5 x 92,8	1984	2	10	85	115	301
AGK	D (A) 4	93 x 103	2799	3	20	92	125	393
AGL	B (NA) 4	90,9 x 88,4	2295	4	8,8	105	143	390
AGN	B (NA) 4	81 x 86,4	1781	5	10,3	92	125	242
AGP	D (NA) 4	79,5 x 95,5	1896	2	19,5	50	68	155
AGR	D (LA) 4	79,5 x 95,5	1896	2	19,5	66	90	151
AGU Euro 2	B (LA) 4	81 x 86,4	1781	5	9,5	110	150	239
AGX	D (LA) 5	81 x 95,5	2461	2	19,5	55	75	259
AGZ	B (NA) 5	81 x 90,2	2324	2	10,1	110	150	238
AHB	D (NA) 4	79,5 x 86,4	1715	2	19,5	42	57	148
AHD	D (LA) 5	81 x 95,5	2461	2	19,5	75	102	259
AHF	D (LA) 4	79,5 x 95,5	1896	2	19,5	81	110	151
AHG	D (NA) 4	79,5 x 86,4	1716	2	19,5	42-44	57-60	148
AHH	D (A) 4	79,5 x 95,5	1896	2	19,5	66	90	152
AHL	B (NA) 4	81 x 77,4	1595	2	10,3	74	101	235
AHS	B (NA) 4	76,5 x 86,9	1598	2	9,8	55	75	52
AHU	D (A) 4	79,5 x 95,5	1896	2	19,5	66-67	90-91	140
AHW	B (NA) 4	76,5 x 75,6	1390	4	10,5	55	75	56
AHY	D (LA) 5	81 x 95,5	2461	2	19,5:1	111	151	259
AJ	B (NA) 4	85,5 x 69	1584	2	7,5:1	36-37	48-50	380
AJA	D (NA) 5	79,5 x 95,5	2370	2	23,5:1	55	75	154
AJH	B (LA) 4	81 x 86,4	1781	5	9,5	110	150	239
AJM	D (A) 4	79,5 x 95,5	1896	2	18	85	115	156
AJS	D (A) 10	81 x 95,5	4921	2	18	230	313	264
AJT	D (A) 5	81 x 95,5	2461	2	19,5:1	65	88	259
AJV	B (NA) 4	76,5 x 86,9	1598	4	10,6	88	120	58
AKK	B (NA) 4	76,5 x 75,6	1390	2	10,4	44	60	54
AKL	B (NA) 4	81 x 77,4	1595	2	10,3	65-76	100-103	235
AKN	D (LA) 6	78,3 x 86,4	2496	4	19,5	110	150	123
AKP	B (NA) 4	76,5 x 75,6	1390	2	10,2	40	54	59
AKQ	B (NA) 4	76,5 x 75,6	1390	4	10,5	55	75	56
AKR	B (NA) 4	82,5 x 92,8	1984	2	10,3	85	115	303
AKS	B (NA) 4	81 x 77,4	1595	2	10,3	74	101	241
AKU	D (NA) 4	79,5 x 86,4	1716	2	19,5	44	60	148
AKV	B (NA) 4	76,5 x 75,6	1390	2	10,2	44	60	49
AKW	D (NA) 4	79,5 x 86,4	1715	2	19,5	42	57	153
ALD	B (NA) 4	67,1 x 70,6	999	2	10,7	37	50	2
ALE	D (LA) 4	79,5 x 95,5	1896	2	19,5	66	90	146
ALG	B (NA) 6	82,5 x 86,4	2771	5	10,6	142	193	302
ALH	D (LA) 4	79,5 x 95,5	1896	2	19,5	66-67	90-91	150
ALL	B (NA) 4	67,1 x 70,6	999	2	10,7	37	50	1
ALM	B (NA) 4	76,5 x 86,9	1598	2	9,8	55	75	53
ALT	B (NA) 4	82,5 x 92,8	1984	5	10,3	96	130	302
ALZ	B (NA) 4	81 x 77,4	1595	2	10,3:1	75	102	255



V



			Cyl.	mm	cm <sup>3</sup>		Comp. Ratio $\epsilon$	kW	PS	Pos
AMF	D (A)	3		79,5 x 95,5	1422	2	19,5	55	75	158
AMV Euro 3	B (NA)	6		81 x 90,3	2792	4	10,75	150	204	249
AMX	B (NA)	6		82,5 x 86,4	2771	5	10,6	142	193	302
AMY	B (NA)	6		81 x 90,3	2792	2	10	128	174	233
AN	B (NA)	4		93 x 66	1795	2	7,8:1	63	86	392
ANA	B (NA)	4		81 x 77,4	1595	2	10,3	74	101	235
ANB	B (A)	4		81 x 86,4	1781	5	9,5	110	150	239
ANC	D (NA)	4		79,5 x 95,5	1896	2	22,5:1	44	60	167
ANF	D (NA)	5		81 x 95,5	2461	2	19,5:1	55	75	260
ANG	D (A)	5		81 x 95,5	2461	2	19,5:1	88	120	260
ANH	D (A)	5		81 x 95,5	2461	2	19,5:1	111	151	260
ANJ	D (A)	5		81 x 95,5	2461	2	19,5	80	109	259
ANM	B (NA)	4		76,5 x 75,5	1390	4	10,5:1	74	101	60
ANN	B (NA)	4		81 x 86,4	1781	2	9	55	75	230
ANP	B (NA)	4		81 x 86,4	1781	2	10	66	90	231
ANU	D (A)	4		79,5 x 95,5	1896	2	18	66	90	157
ANV	B (NA)	4		67,1 x 70,6	999	2	10,7	37	50	2
ANW	B (NA)	4		76,5 x 75,6	1390	2	10,4	44	60	54
ANX	B (NA)	4		76,5 x 75,6	1390	2	10,2	40	54	49
ANY	D (LA)	3		76,5 x 86,4	1191	2	19,5	45	61	116
AP	B (NA)	4		93 x 66	1795	2	7,3	50	68	392
APA	D (LA)	5		81 x 95,5	2461	2	19,5:1	66	90	259
APE	B (NA)	4		76,5 x 75,6	1390	4	10,5	55	75	56
APF	B (NA)	4		81 x 77,4	1595	2	10,3	74	101	235
APH	B (A)	4		81 x 86,4	1781	5	9,5	110	150	239
APK	B (NA)	4		82,5 x 92,8	1984	2	10,5	85	116	305
APL	B (NA)	5		81 x 95,5	2461	2	10	85	115	247
APQ	B (NA)	4		76,5 x 75,6	1390	2	10,2	44	60	49
APR	B (NA)	6		82,5 x 86,4	2771	5	10,6	142	193	302
APT	B (NA)	4		81 x 86,4	1781	5	10,3	92	125	237
APU	B (LA)	4		81 x 86,4	1781	5	9,5	110	150	239
AQA	B (A)	4		81 x 86,4	1781	5	9,5	110	150	239
AQD	B (NA)	6		82,5 x 86,4	2771	5	10,6	142	193	302
AQM	D (NA)	4		79,5 x 95,5	1896	2	19,5	50	68	147
AQN	B (NA)	5		81 x 90,2	2324	4	10,8	125	170	249
AQP	B (NA)	6		81 x 90,3	2792	4	10,75	150	204	245
AQQ	B (NA)	4		76,5 x 75,6	1390	4	10,5	74	101	58
AQY	B (NA)	4		82,5 x 92,8	1984	2	10,4	85	115	305
AQZ	B (NA)	4		67,1 x 70,6	999	2	10,8	53	72	4
AR	B (NA)	4		77 x 69	1285	2	7,5:1	31-32	42-44	119
ARC	B (NA)	4		76,5 x 86,9	1598	4	11,5	92	125	61
ARD	D (NA)	4		79,5 x 95,5	1896	2	22,5:1	44	60	167
ARG	B (NA)	4		81 x 86,4	1781	5	10,3	92	125	237
ARL	D (LA)	4		79,5 x 95,5	1896	2	18,5	110	150	160
ARM	B (NA)	4		81 x 77,4	1595	2	10,3	74	101	235
ARR	B (NA)	4		76,5 x 75,6	1390	4	11,5	77	105	61
ARX	B (LA)	4		81 x 86,4	1781	5	9,5	110	150	250
ARZ	B (A)	4		81 x 86,4	1781	5	9,5	110	150	239
AS	B (NA)	4		85,5 x 69	1584	2	7,5	37	50	379
ASV	D (LA)	4		79,5 x 95,5	1896	2	19,5	81	110	150
ASX	D (NA)	4		79,5 x 95,5	1896	2	22,5:1	47	64	148
ASY	D (NA)	4		79,5 x 95,5	1896	2	19,5	47	64	147
ASZ	D (LA)	4		79,5 x 95,5	1896	2	19	96	130	157
AT	B (NA)	4		93 x 66	1795	2	7,5	55	75	392
ATA	D (A)	4		93 x 103	2799	3	17,8	96	130	393
ATD	D (A)	4		79,5 x 95,5	1896	2	19	74	101	156
ATE	B (NA)	4		67,1 x 70,6	999	2	10,7:1	37	50	3
ATJ	D (LA)	4		79,5 x 95,5	1896	2	18	85	115	156
ATL	D (LA)	3		79,5 x 95,5	1422	2	19,5	66	90	159
ATM	B (NA)	4		82,5 x 92,8	1984	2	10,5	85	115	305
ATN	B (NA)	4		76,5 x 86,9	1598	4	11,5	77	105	57
ATQ	B (NA)	6		82,5 x 86,4	2771	5	10,6	142	193	302
ATU	B (NA)	4		82,5 x 92,8	1984	2	10,4:1	85	116	304
ATX	B (NA)	6		82,5 x 86,4	2771	5	10,6	140	190	302
AUA	B (NA)	4		76,5 x 75,6	1390	4	10,5	55	75	56
AUB	B (NA)	4		76,5 x 75,6	1390	4	10,5	74	101	58
AUC	B (NA)	4		67,1 x 70,6	999	2	10,7	37	50	2
AUD	B (NA)	4		76,5 x 75,6	1390	2	10,4	44	60	54
AUE	B (NA)	6		81 x 90,3	2792	4	10,75	150	204	245

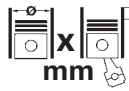

Cyl.	Cyl. Diagram	cm <sup>3</sup>	Comp. Ratio ε	kW	PS	Pos		
AUF	D (A) 5	81 x 95,5	2461	2	19,5:1	75	102	259
AUH	D (A) 4	93 x 103	2799	3	17,8:1	116	158	393
AUM	B (LA) 4	81 x 86,4	1781	5	9,5	110	150	243
AUQ	B (A) 4	81 x 86,4	1781	5	9,5	132-142	180-193	243
AUR	B (NA) 4	81 x 77,4	1595	2	10,3	74	101	235
AUS	B (NA) 4	76,5 x 86,9	1598	4	11,5	77	105	57
AUY	D (LA) 4	79,5 x 95,5	1896	2	18	85	115	157
AVB	D (A) 4	79,5 x 95,5	1896	2	19	74	101	156
AVC	B (A) 4	81 x 86,4	1781	5	9,5	110	150	251
AVF	D (A) 4	79,5 x 95,5	1896	2	19	96	130	157
AVG	D (A) 4	79,5 x 95,5	1896	2	19,5	81	110	149
AVH	B (NA) 4	82,5 x 92,8	1984	2	10,4:1	85-86	115-117	306
AVM Euro 3	D (A) 4	79,5 x 95,5	1896	2	19,5:1	63	86	164
AVQ	D (LA) 4	79,5 x 95,5	1896	2	19	74	100	169
AVR	D (LA) 5	81 x 95,5	2461	2	19,5	80	109	259
AVT	B (NA) 5	81 x 95,5	2461	2	10	85	115	236
AVU	B (NA) 4	81 x 77,4	1595	2	10,3	75	102	252
AVY	B (NA) 4	76,5 x 86,9	1598	4	11,5	92	125	61
AWC	B (LA) 4	81 x 86,4	1781	5	9,5	110	150	239
AWF	B (NA) 4	82,5 x 92,8	1984	2	10,4:1	85	115	304
AWG	B (NA) 4	82,5 x 92,8	1984	2	10,4:1	85	116	304
AWH	B (NA) 4	81 x 77,4	1595	2	10,3	74	101	235
AWM	B (LA) 4	81 x 86,4	1781	5	9,3:1	125	170	248
AWP	B (A) 4	81 x 86,4	1781	5	9,5	132	180	248
AWT	B (A) 4	81 x 86,4	1781	5	9,5	110	150	248
AWU	B (A) 4	81 x 86,4	1781	5	9,5	110	150	243
AWV	B (A) 4	81 x 86,4	1781	5	9,5	110	150	243
AWX	D (A) 4	79,5 x 95,5	1896	2	19	96	130	157
AWY	B (NA) 3	76,5 x 86,9	1198	2	10,8	40	54	65
AXA	BG (NA) 4	82,5 x 92,8	1984	2	10,3	85	115	295
AXB Euro 3	D (LA) 4	79,5 x 95,5	1896	2	18,5	77	105	157
AXC Euro 3	D (LA) 4	79,5 x 95,5	1896	2	19,5:1	63	85	170
AXD Euro 3	D (LA) 5	81 x 95,5	2461	2	18	96	130	265
AXE Euro 3	D (LA) 5	81 x 95,5	2461	2	18	96-128	131-174	268
AXG	D (A) 5	81 x 95,5	2461	2	19,5	111	151	259
AXJ	B (NA) 6	84 x 95,9	3189	4	10,8	165	224	362
AXL	D (LA) 5	81 x 95,5	2461	2	19,5	75	102	259
AXP	B (NA) 4	76,5 x 75,6	1390	4	10,5	55	75	57
AXR	D (LA) 4	79,5 x 95,5	1896	2	19	74	101	161
AXU	B (NA) 4	76,5 x 75,6	1390	4	12	63	86	61
AXW	B (NA) 4	82,5 x 92,8	1984	4	11,5	110	150	307
AXX	B (LA) 4	82,5 x 92,8	1984	4	10,3	147	200	309
AXZ	B (NA) 6	86 x 90,9	3168	4	12	184	250	383
AYC	D (A) 5	81 x 95,5	2461	2	19,5	75	102	259
AYD	B (NA) 4	81 x 77,4	1595	2	10,5	75	102	252
AYH	D (LA) 10	81 x 95,5	4921	2	18,5	230	313	261
AYL	B (NA) 6	81 x 90,3	2792	4	10,5	150	204	249
AYQ	D (NA) 4	79,5 x 95,5	1896	2	19,5:1	47	64	147
AYT	B (NA) 6	84 x 95,9	3189	4	11,25	177	241	365
AYY	D (A) 5	81 x 95,5	2461	2	18	65	88	259
AYZ	D (A) 3	76,5 x 86,4	1191	2	19,5	45	61	116
AZD	B (NA) 4	76,5 x 86,9	1598	4	11,5	77	105	62
AZG	B (NA) 4	82,5 x 92,8	1984	2	10,5	85	115	305
AZH	B (NA) 4	82,5 x 92,8	1984	2	10,5	85	115	305
AZJ	B (NA) 4	82,5 x 92,8	1984	2	10,3	85	115	305
AZM	B (NA) 4	82,5 x 92,8	1984	2	10,5	85	116	305
AZN	B (NA) 4	67,1 x 70,6	999	2	10,5	40-48	54-65	4
AZQ	B (NA) 3	76,5 x 86,9	1198	4	10,5	47	64	64
AZV	D (LA) 4	81 x 95,5	1968	4	18	100	136	267
AZX	B (NA) 5	81 x 90,2	2324	4	10,8	125	170	249
AZZ	B (NA) 6	84 x 95,9	3189	4	11	162	220	365
B	B (NA) 4	85,5 x 69	1584	2	7,5:1	35	48	376
BAA	B (NA) 6	84 x 95,9	3189	4	11,3	162	220	365
BAC	D (LA) 5	81 x 95,5	2461	2	18,5	128	174	265
BAD	B (NA) 4	76,5 x 86,9	1598	4	12	81	110	61
BAF	B (NA) 4	81 x 86,4	1781	5	10,3	92	125	244
BAG	B (NA) 4	76,5 x 86,9	1598	4	12	85	115	68
BAH	B (NA) 4	76,5 x 86,9	1598	2	10,5	74-76	101-103	63
BAN	B (NA) 12	84 x 90,2	5998	4	10,75:1	309	420	362

		Cyl.	 mm	cm <sup>3</sup>		Comp. Ratio $\epsilon$	kW	PS	Pos
BAR	B (NA)	8	84,5 x 92,8	4163	4	12,5:1	231-257	314-350	370
BAU	D (LA)	6	78,3 x 86,4	2496	4	18,5	132	180	124
BAY KAT	D (LA)	3	79,5 x 95,5	1422	2	19,5	55	75	166
BBE	D (A)	5	81 x 95,5	2461	2	19,5:1	61	83	259
BBF	D (A)	5	81 x 95,5	2461	2	19,5:1	70	95	259
BBG	B (NA)	6	82,5 x 86,4	2771	5	10,6	140	190	302
BBM	B (NA)	3	76,5 x 86,9	1198	2	10,5	44	60	66
BBR	D (LA)	5	81 x 95,5	2461	2	19,5:1	80	109	260
BBU	B (LA)	4	81 x 86,4	1781	5	9,5	132	180	248
BBX	B (NA)	4	82,5 x 92,8	1984	2	10,5	85-88	115-120	306
BBY	B (NA)	4	76,5 x 75,6	1390	4	10,5	55	75	56
BBZ	B (NA)	4	76,5 x 75,6	1390	4	10,5	74	101	58
BCA	B (NA)	4	76,5 x 75,6	1390	4	10,5	55	75	57
BCB	B (NA)	4	76,5 x 86,9	1598	4	11,5	77	105	57
BCQ	D (LA)	4	93 x 103	2799	3	17,8	116	158	393
BCT	D (NA)	5	81 x 95,5	2461	2	19,5:1	40	55	260
BCU	D (A)	5	81 x 95,5	2461	2	19,5:1	74	100	260
BCV	D (A)	5	81 x 95,5	2461	2	19,5:1	108	147	260
BDC	B (NA)	4	82,5 x 92,8	1984	2	10,3	85	115	305
BDE	B (NA)	6	81 x 90,3	2792	4	10,75	150	204	246
BDF	B (NA)	6	81 x 90,3	2792	4	10,75	147	200	246
BDG	D (LA)	6	78,3 x 86,4	2496	4	18,5	120	163	124
BDH	D (LA)	6	78,3 x 86,4	2496	4	18,5	132	180	124
BDJ	D (NA)	4	81 x 95,5	1968	2	19:1	51	70	270
BDK	D (NA)	4	81 x 95,5	1968	2	19:1	55	75	270
BDL	B (NA)	6	84 x 95,9	3189	4	11,3	170	231	364
BDN	B (NA)	8	84 x 90,2	3999	4	10,8:1	202	275	363
BDP	B (NA)	8	84 x 90,2	3999	4	10,8:1	202	275	363
BEF	G (NA)	4	82,5 x 92,8	1984	2		43	58	345
BEH	BG (NA)	4	82,5 x 92,8	1984	2	10,4	85	116	295
BEJ	B (NA)	4	82,5 x 92,8	1984	2	10,3	85	115	305
BEQ	D (NA)	4	79,5 x 95,5	1896	2		33	45	167
BER	B (NA)	4	82,5 x 92,8	1984	2	10,3	85	116	305
BEU	D (A)	4	79,5 x 95,5	1896	2	19,5:1	43	58	143
BEV	B (NA)	4	82,5 x 92,8	1984	2	10,3	85-86	116-117	305
BEW	D (LA)	4	79,5 x 95,5	1896	2	19	74	101	163
BFH	B (NA)	6	84 x 95,9	3189	4	11,3	177	241	365
BFQ	B (NA)	4	81 x 77,4	1595	2	10,3	75	102	254
BFS	B (NA)	4	81 x 77,4	1595	2	10,5	75	102	253
BGD	B (NA)	4	82,5 x 92,8	1984	2	10,3	85	115	305
BGG	D (NA)	4	79,5 x 95,5	1896	2	22,5	47	64	168
BGL	D (NA)	4	79,5 x 95,5	1896	2	23:1	37	50	167
BGM Euro 3	D (NA)	4	79,5 x 95,5	1896	2	23:1	29	40	167
BGP	B (NA)	5	82,5 x 92,8	2480	4	10	110-112	150-152	311
BGQ	B (NA)	5	82,5 x 92,8	2480	4	10	110-112	150-152	312
BGU Euro 4	B (NA)	4	81 x 77,4	1595	2	10,5	75	102	256
BGW	D (LA)	4	81 x 95,5	1968	2	18,5	100	136	269
BHK	B (NA)	6	89 x 96,4	3597	4	12	206	280	385
BHP	B (NA)	4	82,5 x 92,8	1984	2	10,3:1	85	115	305
BHW	D (A)	4	81 x 95,5	1968	2	18,5	100	136	269
BHY	B (NA)	4	82,5 x 92,8	1984	2	10,5	85	116	306
BJB	D (LA)	4	79,5 x 95,5	1896	2	19	77	105	169
BJC	D (LA)	4	79,5 x 95,5	1896	2	19,5:1	53	72	187
BJE KAT	AB (NA)	4	67,1 x 70,6	999	2	10,8	52-53	71-72	5
BJJ	D (LA)	5	81 x 95,5	2461	2		65	88	281
BJK	D (LA)	5	81 x 95,5	2461	2		80	109	281
BJL	D (LA)	5	81 x 95,5	2461	2		100	136	281
BJM	D (LA)	5	81 x 95,5	2461	2		120	163	281
BJN	B (NA)	12	84 x 90,2	5998	4	10,7:1	331	450	368
BJX	B (A)	4	81 x 86,4	1781	5	9,5	110	150	248
BKC	D (LA)	4	79,5 x 95,5	1896	2	19	77	105	161
BKD	D (LA)	4	81 x 95,5	1968	4	18	103	140	267
BKF	B (LA)	4	81 x 86,4	1781	5	9,5	110	150	248
BKG	B (NA)	4	76,5 x 75,6	1390	4	12	66	90	70
BKJ	B (NA)	6	84 x 95,9	3189	4	11	162	220	365
BKK	B (NA)	6	84 x 95,9	3189	4	11,3:1	173	235	364
BKL	B (NA)	6	84 x 95,9	3189	4	10,85	177	241	364
BKP	D (LA)	4	81 x 95,5	1968	4	18,5	103	140	267
BKS	D (LA)	6	83 x 91,4	2967	4	17	165	224	349

Cyl.	mm	cm <sup>3</sup>	Comp. Ratio $\epsilon$	kW	PS	Pos		
BKY	B (NA) 4	76,5 x 75,6	1390	4	10,5	55	75	57
BLE	D (LA) 10	81 x 95,5	4921	2	18,5	230	313	262
BLF	B (NA) 4	76,5 x 86,9	1598	4	12	85	115	69
BLG	B (A) 4	76,5 x 75,6	1390	4	10	125	170	72
BLJ	D (LA) 5	81 x 95,5	2461	2	18	120	163	265
BLK	D (LA) 5	81 x 95,5	2461	2	18	120	163	265
BLM	B (NA) 4	76,5 x 75,6	1390	2		61	83	63
BLN	B (NA) 4	76,5 x 75,6	1390	4	12	66	90	71
BLP	B (NA) 4	76,5 x 86,9	1598	4	12	85	115	69
BLR	B (NA) 4	82,5 x 92,8	1984	4	11,5	110	150	308
BLS	D (LA) 4	79,5 x 95,5	1896	2	19:1	77	105	171
BLT	D (LA) 4	79,5 x 95,5	1896	2	19	96	130	172
BLV	B (NA) 6	89 x 95,9	3580	4	12	206	280	385
BLX	B (NA) 4	82,5 x 92,8	1984	4	11,5	110	150	308
BLY	B (NA) 4	82,5 x 92,8	1984	4	11,5	110	150	308
BMA	D (LA) 4	81 x 95,5	1968	4	18,5:1	100	136	267
BMD	B (NA) 3	76,5 x 86,9	1198	2	10,3	40	54	66
BME	B (NA) 3	76,5 x 86,9	1198	4	10,5	47	64	64
BMK	D (LA) 6	83 x 91,4	2967	4	17	165	224	348
BML	B (NA) 6	84 x 95,9	3189	4	11,3	177	241	364
BMM	D (LA) 4	81 x 95,5	1968	2	18,5	103	140	271
BMN	D (LA) 4	81 x 95,5	1968	4	18,5	125	170	276
BMP	D (LA) 4	81 x 95,5	1968	2	18,5	103	140	273
BMR	D (LA) 4	81 x 95,5	1968	4	18:1	125	170	277
BMS	D (LA) 3	79,5 x 95,5	1422	2	19,5	59	80	176
BMT	D (LA) 4	79,5 x 95,5	1896	2	19:1	74	101	165
BMV	B (NA) 6	84 x 95,9	3189	4	11,3	162-177	220-241	366
BMX	B (NA) 6	84 x 95,9	3189	4	11,3	162	220	364
BMY	B (A) 4	76,5 x 75,6	1390	4	10	103	140	72
BNM	D (LA) 3	79,5 x 95,5	1422	2	19,5	51	70	166
BNU	B (LA) 4	81 x 86,4	1781	5	9,5	132	180	248
BNV	D (LA) 3	79,5 x 95,5	1422	2	19,5	59	80	166
BNW	AB (NA) 4	67,1 x 70,6	999	2		50-53	68-72	5
BNX	B (NA) 4	67,1 x 70,6	999	2	10,8	53-56	72-76	4
BNZ	D (LA) 5	81 x 95,5	2461	2	18	96	130	266
BPC	D (LA) 5	81 x 95,5	2461	2	18	128	174	266
BPD	D (LA) 5	81 x 95,5	2461	2	18	120	163	266
BPE	D (LA) 5	81 x 95,5	2461	2	18	128	174	266
BPR	B (NA) 5	82,5 x 92,8	2480	4	9,5:1	110	150	311
BPS	B (NA) 5	82,5 x 92,8	2480	4	9,5:1	110	150	311
BPY	B (LA) 4	82,5 x 92,8	1984	4	10,3	147	200	309
BRJ	B (NA) 6	84 x 95,9	3189	4	10,8	162	220	364
BRK	B (NA) 6	84 x 95,9	3189	4	10,85	177	241	364
BRM	D (LA) 4	79,5 x 95,5	1896	2	19:1	74	101	179
BRN	B (NA) 12	84 x 90,2	5998	4	10,8:1	331	450	368
BRR Euro 4	D (LA) 4	79,5 x 95,5	1896	2	19,5:1	62	84	180
BRS Euro 4	D (LA) 4	79,5 x 95,5	1896	2	19:1	75	102	180
BRT	D (LA) 4	81 x 95,5	1968	2	18,5	103	140	280
BRU	D (LA) 4	79,5 x 95,5	1896	2	19	66	90	173
BSE Euro 4/5	B (NA) 4	81 x 77,4	1595	2	10,5	75	102	257
BSF Euro 2	B (NA) 4	81 x 77,4	1595	2	10,5	75	102	257
BSP	D (LA) 6	83 x 91,4	2967	4	17:1	165	225	361
BST	D (NA) 4	81 x 95,5	1968	2	19	51	70	270
BSU	D (A) 4	79,5 x 95,5	1896	2	19,5:1	55	75	180
BSW	D (LA) 4	79,5 x 95,5	1896	2	19	77	105	178
BSX	BG (NA) 4	82,5 x 92,8	1984	2	10,3:1	80	109	295
BTB	D (LA) 4	79,5 x 95,5	1896	2	19:1	110	150	177
BTK	B (NA) 5	82,5 x 92,8	2480	4	9,5:1	110-112	150-152	312
BTS	B (NA) 4	76,5 x 86,9	1598	4	10,5	77	105	74
BTT	B (NA) 12	84 x 90,2	5998	4	10,8:1	331	450	368
BTW	D (A) 5	81 x 95,5	2461	2	18:1	121	165	260
BTY	B (NA) 4	67,1 x 70,6	999	2		48-53	65-72	4
BUB	B (NA) 6	84 x 95,9	3189	4	10,85	184	250	364
BUD	B (NA) 4	76,5 x 75,6	1390	4	10,5	59-60	80-82	75
BUN	D (LA) 6	83 x 91,4	2967	4	17	155	211	349
BUZ	D (LA) 4	81 x 95,5	1968	4	18,5	120	163	276
BVB	D (LA) 4	81 x 95,5	1968	4	18:1	96	131	286
BVD	D (LA) 4	81 x 95,5	1968	4		90	122	293
BVE	D (LA) 4	81 x 95,5	1968	4	18:1	90	122	275

V

		Cyl.	mm	cm <sup>3</sup>		Comp. Ratio $\epsilon$	kW	PS	Pos
BVH	D (LA)	4	81 x 95,5	1968	2	18,5	100	136	273
BVK	D (LA)	4	79,5 x 95,5	1896	2	18	85	115	162
BVX	B (NA)	4	82,5 x 92,8	1984	4	11,5	110	150	308
BVY	B (NA)	4	82,5 x 92,8	1984	4	11,5	110	150	308
BVZ	B (NA)	4	82,5 x 92,8	1984	4	11,5	110	150	308
BWA	B (LA)	4	82,5 x 92,8	1984	4	10,3	147	200	309
BWB	D (LA)	3	79,5 x 95,5	1422	2	19,5	51	70	176
BWF	D (LA)	10	81 x 95,5	4921	2	18,5	230	313	263
BWK	B (LA)	4	76,5 x 75,6	1390	4	10:1	110	150	79
BWS	B (NA)	6	89 x 96,4	3597	4	11,4	220	300	385
BWV	D (LA)	4	81 x 95,5	1968	4	18,5	88	120	279
BXE	D (LA)	4	79,5 x 95,5	1896	2	19	77	105	161
BXF	D (LA)	4	79,5 x 95,5	1896	2	19	66	90	174
BXJ	D (LA)	4	79,5 x 95,5	1896	2	19,5	66	90	175
BXT	D (A)	4	79,5 x 95,5	1896	2	19:1	30	41	188
BYD Euro 4	B (LA)	4	82,5 x 92,8	1984	4	9,8	169	230	314
BZB	B (A)	4	82,5 x 84,2	1798	4	9,6	118	160	315
BZG	B (NA)	3	76,5 x 86,9	1198	4	10,5	51	69	64
CA	B (NA)	4	90 x 66	1679	2	7,3	49	66	389
CAAA Euro 5	D (LA)	4	81 x 95,5	1968	4	16,5	62	84	272
CAAB Euro 5	D (LA)	4	81 x 95,5	1968	4	16,5	75	102	272
CAAC Euro 5	D (LA)	4	81 x 95,5	1968	4	16,5	103	140	272
CAAD	D (LA)	4	81 x 95,5	1968	4		84	114	272
CAAE	D (A)	4	81 x 95,5	1968	4		100	136	272
CARA	D (A)	6	83 x 91,4	2967	4	17:1	171	233	352
CARB	D (A)	6	83 x 91,4	2967	4	17:1	176	239	355
CASA	D (LA)	6	83 x 91,4	2967	4	16,8:1	176	240	351
CASB	D (LA)	6	83 x 91,4	2967	4	16,8	155	211	351
CASC	D (LA)	6	83 x 91,4	2967	4	16,8:1	176	240	353
CASD Euro 5	D (A)	6	83 x 91,4	2967	4		150	204	356
CATA	D (LA)	6	83 x 91,4	2967	4	16,8	165	224	350
CAVA	B (A)	4	76,5 x 75,6	1390	4	10:1	110	150	80
CAVB	B (LA)	4	76,5 x 75,6	1390	4	10	125	170	77
CAVC	B (LA)	4	76,5 x 75,6	1390	4	10	103	140	73
CAVD	B (A)	4	76,5 x 75,6	1390	4	10:1	118	160	73
CAVE	B (A)	4	76,5 x 75,6	1390	4	10	132	180	86
CAWA	B (LA)	4	82,5 x 92,8	1984	4	10,5:1	125	170	310
CAWB	B (LA)	4	82,5 x 92,8	1984	4	10,5	147	200	310
CAXA Euro 5	B (LA)	4	76,5 x 75,6	1390	4	10	90	122	78
CAYA	D (LA)	4	79,5 x 80,5	1598	4		55	75	182
CAYB Euro 5	D (LA)	4	79,5 x 80,5	1598	4	16,5	66	90	181
CAYC	D (LA)	4	79,5 x 80,5	1598	4	16,5	77	105	181
CAYD	D (LA)	4	79,5 x 80,5	1598	4	16,5	75	102	181
CAYE	D (LA)	4	79,5 x 80,5	1598	4	16,5	55	75	182
CB	B (NA)	4	90 x 66	1679	2	7,3	49	67	389
CBAA	D (LA)	4	81 x 95,5	1968	4	16,5	100	136	272
CBAB	D (LA)	4	81 x 95,5	1968	4	16,5	103	140	272
CBAC	D (LA)	4	81 x 95,5	1968	4	16,5	105	143	278
CBBA	D (LA)	4	81 x 95,5	1968	4	18,5:1	120	163	278
CBBB	D (LA)	4	81 x 95,5	1968	4	16,5	125	170	272
CBDA	D (LA)	4	81 x 95,5	1968	4	16,5:1	100	136	272
CBDB	D (LA)	4	81 x 95,5	1968	4	16,5:1	103	140	272
CBDC	D (LA)	4	81 x 95,5	1968	4	16,5:1	81	110	278
CBEA	D (LA)	4	81 x 95,5	1968	4	18	103	140	278
CBFA	B (LA)	4	82,5 x 92,8	1984	4	10,5	147-157	200-213	310
CBHA	D (A)	4	81 x 95,5	1968	2		47	64	284
CBJA	D (LA)	4	81 x 95,5	1968	2		55	75	284
CBJB	D (A)	4	81 x 95,5	1968	2		55	75	284
CBKA	D (A)	4	81 x 95,5	1968	2		74	101	285
CBPA	B (NA)	4	82,5 x 92,8	1984	2		85-86	116-117	306
CBRA	B (NA)	6	84 x 95,9	3189	4	10,85	184	250	367
CBSA	G (NA)	4	82,5 x 92,8	1984	2		37	50	346
CBTA	B (NA)	5	82,5 x 92,8	2480	4		112-127	152-173	312
CBUA	B (NA)	5	82,5 x 92,8	2480	4	9,5	112-127	152-173	312
CBWA	D (LA)	10	81 x 95,5	4921	2	18,5:1	230-257	313-350	262
CBZA	B (A)	4	71 x 75,6	1197	2	10	63	86	9
CBZB Euro 5	B (A)	4	71 x 75,6	1197	2	10	77	105	8
CBZC	B (A)	4	71 x 75,6	1197	2	10,0:1	66	90	10
CCCA	B (NA)	5	82,5 x 92,8	2480	4		125	170	312











			Cyl.	mm	cm <sup>3</sup>		Comp. Ratio $\epsilon$	kW	PS	Pos
CCHA	D (A)	4	4	81 x 95,5	1968	4		103	140	272
CCHB	D (A)	4	4	81 x 95,5	1968	4		100	136	272
CCNA	B (NA)	4	4	67,1 x 70,6	999	2	10,8	51-56	69-76	4
CCRA	AB (NA)	4	4	76,5 x 86,9	1598	2	10,5	74-77	101-105	95
CCSA Euro 4/5	B (NA)	4	4	81 x 77,4	1595	2	10,5	75	102	257
CCTA	B (LA)	4	4	82,5 x 92,8	1984	4	10,5	147-157	200-213	310
CCTB	B (LA)	4	4	82,5 x 92,8	1984	4		125	170	310
CCZA	B (LA)	4	4	82,5 x 92,8	1984	4	9,6	147	200	313
CCZB	B (A)	4	4	82,5 x 92,8	1984	4		155	211	313
CCZC	B (LA)	4	4	82,5 x 92,8	1984	4	9,6:1	125	170	317
CCZD	B (LA)	4	4	82,5 x 92,8	1984	4	9,6:1	132	180	321
CDAA	B (LA)	4	4	82,5 x 84,1	1798	4	9,6	118	160	316
CDAB	B (LA)	4	4	82,5 x 84,1	1798	4	9,6	112	152	319
CDBA	D (LA)	4	4	81 x 95,5	1968	4	16,5	90	122	272
CDCA	D (LA)	4	4	81 x 95,5	1968	4	16,5	120	163	272
CDGA	BG (A)	4	4	76,5 x 75,6	1390	4		110	150	45
CDLA	B (LA)	4	4	82,5 x 92,8	1984	4	9,8	195	265	320
CDLC	B (LA)	4	4	82,5 x 92,8	1984	4		188	256	314
CDLF	B (LA)	4	4	82,5 x 92,8	1984	4	9,8	199	270	314
CDLJ Euro 6	B (LA)	4	4	82,5 x 92,8	1984	4	9,8	162	220	320
CDVA Euro 5	B (NA)	6	6	89 x 96,4	3597	4	11,4	191	260	388
CDXA	D (A)	4	4	79,5 x 95,5	1896	2	23:1	55	75	167
CDXB	D (A)	4	4	79,5 x 95,5	1896	2	23:1	29	40	167
CEAA	B (A)	4	4	82,5 x 84,2	1798	4		118	160	343
CEBA	D (LA)	5	5	81 x 95,5	2461	2	16,8:1	65	88	282
CEBB	D (LA)	5	5	81 x 95,5	2461	2	16,8:1	80	109	282
CECA	D (LA)	5	5	81 x 95,5	2461	2	16,8:1	100	136	283
CECB	D (LA)	5	5	81 x 95,5	2461	2	16,8:1	120	163	282
CEGA	D (A)	4	4	81 x 95,5	1968	4	16,5	125	170	272
CEXA	D (A)	6	6	83 x 91,4	2967	4		176	240	351
CEXB Euro 5	D (A)	6	6	83 x 91,4	2967	4		180	245	361
CEZA	D (A)	6	6	83 x 91,4	2967	4		195	265	354
CFCA Euro 5	D (LA)	4	4	81 x 95,5	1968	4	16,5	132	180	288
CFEA	AB (NA)	4	4	82,5 x 92,8	1984	2		85-88	116-120	344
CFFA	D (LA)	4	4	81 x 95,5	1968	4	16	100	136	272
CFFB	D (LA)	4	4	81 x 95,5	1968	4	16,5	103	140	272
CFFD	D (LA)	4	4	81 x 95,5	1968	4		81	110	272
CFFE	D (LA)	4	4	81 x 95,5	1968	4	16,5	85	115	287
CFGB	D (LA)	4	4	81 x 95,5	1968	4	16,5	125	170	272
CFGC	D (A)	4	4	81 x 95,5	1968	4	16	130	177	272
CFHB	D (LA)	4	4	81 x 95,5	1968	4	16,5:1	100	136	274
CFHC	D (LA)	4	4	81 x 95,5	1968	4	16,5:1	103	140	272
CFHE	D (LA)	4	4	81 x 95,5	1968	4	16,5	62	85	272
CFHF	D (A)	4	4	81 x 95,5	1968	4	16,5:1	81	110	272
CFJA	D (A)	4	4	81 x 95,5	1968	4	16,5	125	170	272
CFJB	D (A)	4	4	81 x 95,5	1968	4	16	130	177	278
CFLA	B (NA)	6	6	84 x 95,9	3189	4		173	235	367
CFNA Euro 4	B (NA)	4	4	76,5 x 86,9	1598	4	10,5	77	105	84
CFNB Euro 4	B (NA)	4	4	76,5 x 86,9	1598	4	10,5	63	86	88
CFPA Euro 4	B (LA)	4	4	82,5 x 92,8	1984	4	9,6	118	160	321
CFRA	B (NA)	12	12	84 x 90,2	5998	4		331	450	368
CFWA	D (A)	3	3	79,5 x 80,5	1199	4	16,5	55	75	183
CFZA	B (NA)	4	4	76,5 x 86,9	1598	2	10,5	74-76	101-103	67
CGEA Euro 5	B (LA)	6	6	84,5 x 89	2995	4	13,3:1	245	333	371
CGFA Euro 5	B (LA)	6	6	84,5 x 89	2995	4	13,3:1	245-283	333-385	372
CGGA	B (NA)	4	4	76,5 x 75,6	1390	4	10,5	59	80	76
CGGB Euro 5	B (NA)	4	4	76,5 x 75,6	1390	4	10,5:1	63	85	76
CGMA	B (A)	4	4	82,5 x 92,8	1984	4		147	200	343
CGNA	B (NA)	8	8	84,5 x 92,8	4163	4		265	360	374
CGPA	B (NA)	3	3	76,5 x 86,9	1198	4	10,5	51	70	64
CGPB	B (NA)	3	3	76,5 x 86,9	1198	4	10,5	44	60	64
CGRA Euro 5	B (NA)	6	6	89 x 96,4	3597	4	11,4	206	280	387
CGYA	B (A)	4	4	82,5 x 84,1	1798	4	9,6	112	152	318
CH	B (NA)	4	4	86,5 x 84,4	1984	2	8	55	75	384
CHFA	B (NA)	3	3	76,5 x 86,9	1198	2	10,5	44	60	66
CHFB Euro 4	B (NA)	3	3	76,5 x 86,9	1198	2	10,3	40	54	66
CHGA	BG (NA)	4	4	81 x 77,4	1595	2		75	102	189
CHHA	B (LA)	4	4	82,5 x 92,8	1984	4	9,6	169	230	325
CHHB Euro 6	B (LA)	4	4	82,5 x 92,8	1984	4	9,6	162	220	325



		Cyl.	mm	cm <sup>3</sup>		Comp. Ratio $\epsilon$	kW	PS	Pos
CHNA	B (NA)	6	89 x 96,35	3597	4	12	206	280	387
CHPA Euro 5	B (LA)	4	74,5 x 80	1395	4	10,5	103	140	22
CHPB Euro 6	B (LA)	4	74,5 x 80	1395	4	10	110	150	22
CHYA Filter	B (NA)	3	74,5 x 76,4	999	4		44	60	20
CHYB Filter	B (NA)	3	74,5 x 76,4	999	4	10,5	55	75	20
CHYC Filter	B (NA)	3	74,5 x 76,4	999	4		48	65	21
CHZA	B (A)	3	74,5 x 76,4	999	4		66	90	19
CHZB Euro 6	B (A)	3	74,5 x 76,4	999	4	10,5	70	95	19
CHZC Euro 6	B (A)	3	74,5 x 76,4	999	4	10,5	81	110	19
CHZD	B (LA)	3	74,5 x 76,4	999	4	10,5	85	115	27
CHZG	B (LA)	3	74,5 x 76,4	999	4		75	102	19
CHZJ	B (A)	3	74,5 x 76,4	999	4		85	115	26
CHZK	B (A)	3	74,5 x 76,4	999	4		63	86	19
CHZL	B (A)	3	74,5 x 76,4	999	4	10,5	70	95	19
CJ	B (NA)	4	94 x 71	1970	2	7,3	51	70	394
CJAA	D (LA)	4	81 x 95,5	1968	4		103-104	140-141	272
CJGD	D (LA)	6	83 x 91,4	2967	4		180	245	360
CJKA	B (A)	4	82,5 x 92,8	1984	4	10,5:1	150	204	321
CJKB	B (A)	4	82,5 x 92,8	1984	4		110	150	322
CJLA	B (NA)	3	76,5 x 86,9	1198	4		55	75	91
CJMA	D (A)	6	83 x 91,4	2967	4		150	204	357
CJSA Euro 6	B (LA)	4	82,5 x 84,1	1798	4	9,6	132	180	340
CJSB Euro 6	B (LA)	4	82,5 x 84,1	1798	4	9,6	132	180	339
CJSC Euro 6	B (LA)	4	82,5 x 84,1	1798	4	9,6	132	180	341
CJTA Euro 5	B (K)	6	84,5 x 89	2995	4	10,5	213	290	373
CJXA	B (A)	4	82,5 x 92,8	1984	4		206	280	326
CJXB Euro 6	B (A)	4	82,5 x 92,8	1984	4		206	280	333
CJXC Euro 6	B (LA)	4	82,5 x 92,8	1984	4	9,3:1	221-265	300-360	334
CJXD Euro 6	B (LA)	4	82,5 x 92,8	1984	4		213	290	335
CJXE Euro 6	B (LA)	4	82,5 x 92,8	1984	4		195	265	326
CJXG Euro 6	B (LA)	4	82,5 x 92,8	1984	4		228	310	335
CJZA	B (LA)	4	71 x 75,6	1197	4	10,5	77	105	13
CJZB Euro 5	B (LA)	4	71 x 75,6	1197	4	10,5	63	86	11
CJZC Euro 6	B (A)	4	71 x 75,6	1197	4	10,5	66	90	16
CJZD Euro 6	B (LA)	4	71 x 75,6	1197	4	10,5	81	110	15
CK	D (NA)	4	76,5 x 80	1471	2	23,5	37	50	98
CKDA Euro 5	D (LA)	8	83 x 95,5	4134	4	16,4	250	340	358
CKFC Euro 5	D (LA)	4	81 x 95,5	1968	4	16	110	150	278
CKMA	AB (A)	4	76,5 x 75,6	1390	4	10	118	160	96
CKRA Euro 6	D (LA)	4	81 x 95,5	1968	4	16,5	103	140	278
CKTB	D (LA)	4	81 x 95,5	1968	4	16	80	109	272
CKTC	D (LA)	4	81 x 95,5	1968	4	16	100	136	272
CKUB	D (LA)	4	81 x 95,5	1968	4	16	120	163	272
CKUC	D (LA)	4	81 x 95,5	1968	4	16	105	142	272
CLCA	D (LA)	4	81 x 95,5	1968	4	16,5	81	110	272
CLCB	D (A)	4	81 x 95,5	1968	4	16,5	103	140	272
CLHA Euro 5	D (LA)	4	79,5 x 80,5	1598	4	16,2	77	105	182
CLHB Euro 5	D (LA)	4	79,5 x 80,5	1598	4	16,2	66	90	182
CLJA	D (LA)	4	81 x 95,5	1968	4	18,5	103	140	272
CLLA	D (LA)	4	81 x 95,5	1968	4		125	170	287
CLNA Euro 5	D (LA)	4	79,5 x 80,5	1598	4	16,5	77	105	181
CLPA Euro 5	B (NA)	4	76,5 x 75,6	1390	4	10,5:1	63	85	83
CLRA Euro 4	B (NA)	4	76,5 x 86,9	1598	4	10,5	77	105	88
CLSA	B (NA)	4	76,5 x 86,9	1598	4	10,5	77	105	84
CMAA	B (NA)	4	76,5 x 75,6	1390	4		60	82	85
CMBA Euro 5	B (LA)	4	74,5 x 80	1395	4	10	90	122	22
CMSB Euro 4	B (LA)	4	76,5 x 75,6	1390	4	10	90	122	82
CMTA Euro 5	B (NA)	6	89 x 96,4	3597	4	11,4	183	249	387
CMVA	B (NA)	6	89 x 96,4	3597	4	11,4	206	280	387
CMXA Euro 5	B (NA)	4	81 x 77,4	1595	2	10,5	75	102	254
CNBA	B (NA)	4	76,5 x 75,6	1390	2		61	83	89
CNEA	D (LA)	4	81 x 95,5	1968	4	16	132	180	272
CNFA	D (LA)	4	81 x 95,5	1968	4	16	90	122	272
CNFB	D (LA)	4	81 x 95,5	1968	4	16	103	140	272
CNKA	B (NA)	4	76,5 x 86,9	1598	4		60	82	90
CNLA	B (LA)	4	74,5 x 80	1395	4	10,5	110	150	19
CNNA	B (NA)	6	89 x 95,9	3580	4	11,4	206	280	386
CNRB	D (LA)	6	83 x 91,4	2967	4		176	240	357
CNSB Euro 6	B (A)	4	82,5 x 84,1	1798	4		125	170	329

									
		Cyl.		mm	cm <sup>3</sup>	Comp. Ratio ε	kW	PS	Pos
CNTA Euro 6	B (A)	4	82,5 x 92,8	1984	4	9,6	155	211	335
CNTC Euro 6	B (A)	4	82,5 x 92,8	1984	4	9,6	162	220	327
CNWA	B (A)	4	76,5 x 75,6	1390	4		118	160	81
CNWB	B (A)	4	76,5 x 75,6	1390	4	10	110	150	83
CP	D (NA)	6	76,5 x 86,4	2383	2	23,5	55	75	98
CPFA	B (NA)	6	84 x 89,5	2975	4	11,4	184	250	369
CPGA Euro 5	BG (NA)	3	74,51 x 76,4	999	4	11,5:1	50	68	28
CPKA	B (A)	4	82,5 x 84,1	1798	4		125	170	328
CPLA	B (LA)	4	82,5 x 92,8	1984	4		155	211	323
CPPA	B (LA)	4	82,5 x 92,8	1984	4		155	211	324
CPRA	B (A)	4	82,5 x 84,1	1798	4		125	170	328
CPTA Euro 5	B (LA)	4	74,5 x 80	1395	4	10,5	103	140	23
CPVA Euro 5	B (LA)	4	74,5 x 80	1395	4	10,5	90	122	24
CPVB Euro 6	B (LA)	4	74,5 x 80	1395	4	10	92	125	25
CPWA	BG (A)	4	74,5 x 80	1395	4	10,5	81	110	17
CR	D (NA)	4	76,5 x 86,4	1588	2	23,5	39-40	52-54	102
CRBC Euro 5	D (LA)	4	81 x 95,5	1968	4	16,2	110	150	278
CRCA	D (LA)	6	83 x 91,4	2967	4		180	245	357
CRCD	D (A)	6	83 x 91,4	2967	4		150	204	359
CRFD Euro 4	D (LA)	4	81 x 95,5	1968	4	16,2	105	143	289
CRGA Euro 4	D (LA)	4	81 x 95,5	1968	4	15,5-16,2	130	177	289
CRGB Euro 4	D (LA)	4	81 x 95,5	1968	4	16,2	130	177	289
CRJA	B (LA)	4	74,5 x 80	1395	4	10,5	110	150	19
CRKA Euro 6	D (LA)	4	79,5 x 80,5	1598	4	16,2	66	90	182
CRKB Filter	D (LA)	4	79,5 x 80,5	1598	4	16,2	81	110	182
CRLB Euro 6	D (LA)	4	81 x 95,5	1968	4	16,2	110	150	278
CRLD Euro 6	D (LA)	4	81 x 95,5	1968	4	16,2	81	110	289
CRMB Euro 6	D (LA)	4	81 x 95,5	1968	4	16,2	110	150	278
CRVA Euro 4	D (LA)	4	81 x 95,5	1968	4	16,2	81	110	278
CRVC Euro 4	D (LA)	4	81 x 95,5	1968	4	16	105	143	290
CS	D (NA)	4	76,5 x 86,4	1588	2	23,5	37	50	103
CSHA	D (LA)	4	81 x 95,5	1968	4	16	132	180	272
CSLA	D (LA)	4	81 x 95,5	1968	4	15,5	80	109	289
CSLB	D (LA)	4	81 x 95,5	1968	4	15,5	84	114	289
CSLC	D (LA)	4	81 x 95,5	1968	4	15,5	103	140	289
CSNA	D (LA)	4	81 x 95,5	1968	4	15,5	120	163	289
CT	AB (NA)	4	85,5 x 69	1584	2	7,5	37-50	50-67	382
CTHA	B (A)	4	76,5 x 75,6	1390	4	10,0:1	110	150	81
CTHB	B (LA)	4	76,5 x 75,6	1390	4	10	125	170	83
CTHC	B (LA)	4	76,5 x 75,6	1390	4	10	103	140	83
CTHD	B (A)	4	76,5 x 75,6	1390	4	10	118	160	80
CTHE	B (A)	4	76,5 x 75,6	1390	4	10	132	180	87
CTKA	B (A)	4	76,5 x 75,6	1390	4	10,0:1	118	160	81
CU	B (NA)	4	94 x 71	1970	2	7,3	51	70	394
CUCA	G (NA)	4	76,5 x 86,9	1598	4	0	70	95	97
CUKA Euro 6	B (LA)	4	74,5 x 80	1395	4		90	122	19
CUKB Euro 6	B (LA)	4	74,5 x 80	1395	4	10	110	150	19
CUKC Euro 6	B (LA)	4	74,5 x 80	1395	4		115	156	19
CULA Euro 6	B (A)	4	82,5 x 92,8	1984	4	9,6	132	180	331
CULC	B (LA)	4	82,5 x 92,8	1984	4		162	220	332
CUNA Euro 6	D (LA)	4	81 x 95,5	1968	4	15,8	135	184	278
CUSA Euro 6	D (LA)	3	79,5 x 95,5	1422	4	16,2	55	75	184
CUSB Euro 6	D (LA)	3	79,5 x 95,5	1422	4	16,2	66	90	184
CUTA Euro 6	D (A)	3	79,5 x 95,5	1422	4	16,2	77	105	184
CUUA	D (A)	4	81 x 95,5	1968	4		81	110	289
CUUB	D (A)	4	81 x 95,5	1968	4	16,2	110	150	289
CUUC	D (A)	4	81 x 95,5	1968	4	16,2	55	75	289
CUUD	D (A)	4	81 x 95,5	1968	4		75	102	289
CUUE	D (A)	4	81 x 95,5	1968	4		90	122	289
CUUF	D (A)	4	81 x 95,5	1968	4		55	75	289
CUVA Euro 6	D (LA)	4	81 x 95,5	1968	4	16,2	85	115	289
CUVC Euro 6	D (LA)	4	81 x 95,5	1968	4	16,2	110	150	289
CV	B (NA)	4	94 x 71	1970	2	7,3	51	70	395
CVVA	D (A)	6	83 x 91,4	2967	4	16,8	193	262	359
CVWA	D (A)	6	83 x 91,4	2967	4	16,8	150	204	359
CWVA Euro 5	B (NA)	4	76,5 x 86,9	1598	4	10,5	81	110	92
CWVB Euro 5	B (NA)	4	76,5 x 86,9	1598	4	10,5	66	90	92
CXBA	B (A)	4	82,5 x 84,1	1798	4		125	170	330

			Cyl.	mm	cm <sup>3</sup>		Comp. Ratio $\epsilon$	kW	PS	Pos
CXBB	B (A)	4	4	82,5 x 84,1	1798	4		125	170	330
CXCA Euro 6	B (A)	4	4	82,5 x 92,8	1984	4	9,6	155	211	326
CXCB Euro 6	B (A)	4	4	82,5 x 92,8	1984	4	9,6	162	220	326
CXDA Euro 6	B (LA)	4	4	82,5 x 92,8	1984	4	9,6	162	220	326
CXEB Euro 6	D (LA)	4	4	81 x 95,5	1968	4	15,5	150	204	292
CXEC Euro 6	D (LA)	4	4	81 x 95,5	1968	4	15,5	146	199	292
CXFA Euro 6	D (LA)	4	4	81 x 95,5	1968	4	15,5	110	150	292
CXGA Euro 6	D (LA)	4	4	81 x 95,5	1968	4	15,5	62	84	292
CXGB Euro 6	D (LA)	4	4	81 x 95,5	1968	4		75	102	292
CXGD Euro 6	D (LA)	4	4	81 x 95,5	1968	4		66	90	292
CXHA Euro 6	D (LA)	4	4	81 x 95,5	1968	4	15,5	110	150	292
CXHB Euro 6	D (LA)	4	4	81 x 95,5	1968	4		84	114	292
CXHC Euro 6	D (LA)	4	4	81 x 95,5	1968	4		81	110	292
CXSA Euro 5	B (LA)	4	4	74,5 x 80	1395	4	10,5	90	122	22
CXSB Euro 6	B (LA)	4	4	74,5 x 80	1395	4	10	92	125	24
CXXA Euro 6	D (LA)	4	4	79,5 x 80,5	1598	4	16,2	66	90	184
CXXB Euro 6	D (LA)	4	4	79,5 x 80,5	1598	4	16,2	81	110	184
CY	D (A)	4	4	76,5 x 86,4	1588	2	23	51	70	104
CYFB	B (A)	4	4	82,5 x 92,8	1984	4		215	292	336
CYJA	B (K)	6	6	84,5 x 89	2995	4	10,5	235	320	375
CYKA	D (A)	4	4	81 x 95,5	1968	4		110	150	289
CYKB Euro 5	D (LA)	4	4	81 x 95,5	1968	4	16,2	81	110	289
CYKC Euro 5	D (LA)	4	4	81 x 95,5	1968	4	16,2	81	110	289
CYVA Euro 6	B (LA)	4	4	71 x 75,6	1197	4	10,5	63	86	12
CYVB	B (LA)	4	4	71 x 75,6	1197	4	10,5	81	110	12
CYVC	B (A)	4	4	71 x 75,6	1197	4		62	84	14
CYVD	B (A)	4	4	71 x 75,6	1197	4		77	105	14
CZ	B	4	4	85,5 x 69	1584	2	7,5:1	34	46	381
CZCA Euro 6	B (LA)	4	4	74,5 x 80	1395	4	10	92	125	19
CZCB	B (A)	4	4	74,5 x 80	1395	4	10,5	92	125	19
CZDA Euro 6	B (LA)	4	4	74,5 x 80	1395	4	10	110	150	19
CZDB	B (A)	4	4	74,5 x 80	1395	4		92	125	19
CZDC	B (A)	4	4	74,5 x 80	1395	4	10	96	130	19
CZDD	B (A)	4	4	74,5 x 80	1395	4		92	125	19
CZEA Euro 6	B (LA)	4	4	74,5 x 80	1395	4	10	110	150	21
CZPA Euro 6	B (A)	4	4	82,5 x 92,8	1984	4	11,65	132	180	342
CZPB Euro 6	B (A)	4	4	82,5 x 92,8	1984	4	11,65	140	190	342
CZPC Euro 6	B (A)	4	4	82,5 x 92,8	1984	4	11,65	147	200	342
CZTA	B (A)	4	4	74,5 x 80	1395	4	10	110	150	19
D 0834 LFL 63 Euro 5	D (LA)	4	4	108 x 125	4580	4		110	150	404
D 0834 LFL 64 Euro 5	D (LA)	4	4	108 x 125	4580	4		132-137	180-186	404
D 0834 LFL 65 Euro 5	D (LA)	4	4	108 x 125	4580	4		162-166	220-226	404
D 0836 LFL 64 Euro 5	D (LA)	6	6	108 x 125	6871	4		202-213	275-290	404
D 0836 LOH 64 Euro 5	D (LA)	6	6	108 x 125	6871	4		209-213	284-290	404
DAFA	B (NA)	3	3	74,5 x 76,4	999	4		44	60	21
DAJA	B (LA)	4	4	82,5 x 84,2	1798	4	9,6	141-169	192-230	337
DAJB	B (LA)	4	4	82,5 x 84,2	1798	4		141	192	338
DAUA	D (A)	4	4	81 x 95,5	1968	4		103	140	292
DAUB	D (A)	4	4	81 x 95,5	1968	4		75	102	292
DAVA	D (LA)	4	4	81 x 95,5	1968	4		130	177	292
DBGA Euro 5	D (LA)	4	4	81 x 95,5	1968	4	16,2	110	150	289
DBGB	D (LA)	4	4	81 x 95,5	1968	4	16,2	81	110	289
DBGC Euro 5	D (A)	4	4	81 x 95,5	1968	4	16,2	110	150	289
DBKA Euro 6	D (LA)	4	4	79,5 x 80,5	1598	4	16,2	81	110	185
DBYA Euro 6	BG (A)	3	3	74,5 x 76,4	999	4	10,5	66	90	18
DCXA Euro 6	D (A)	4	4	79,5 x 80,5	1598	4		88	120	184
DCYA Euro 6	D (LA)	4	4	81 x 95,5	1968	4	16,2	110	150	289
DCYB Euro 6	D (A)	4	4	81 x 95,5	1968	4	16,2	81	110	289
DDAA Euro 6	D (A)	4	4	81 x 95,5	1968	4	15,8	140	190	291
DDYA Euro 6	D (LA)	4	4	79,5 x 80,5	1598	4	16,2	85	115	186
DDYB Euro 6	D (LA)	4	4	79,5 x 80,5	1598	4	16,2	66	90	186
DEDA	B (LA)	4	4	82,5 x 92,8	1984	4	9,6	162	220	337
DF	B (NA)	4	4	94 x 68,9	1913	2	8,4	44	60	396
DFCA	D (A)	4	4	81 x 95,5	1968	4	15,5	140	190	289
DFEA Euro 6	D (LA)	4	4	81 x 95,5	1968	4	16,2	110	150	289
DFEB Euro 6	D (LA)	4	4	81 x 95,5	1968	4	16,2	81	110	289
DFGA Euro 6	D (LA)	4	4	81 x 95,5	1968	4	16,2	110	150	289
DFGB Euro 6	D (LA)	4	4	81 x 95,5	1968	4	16	81	110	289
DFGC Euro 6	D (LA)	4	4	81 x 95,5	1968	4	16,2	85	115	289



			Cyl.		mm	cm <sup>3</sup>	Comp. Ratio $\epsilon$	kW	PS	Pos
DFHA Euro 6	D (LA)	4	81 x 95,5	1968	4	15,5-16,2	140	190	289	
DFNA Euro 6	B (LA)	3	74,5 x 76,4	999	4		59	80	21	
DFNB Euro 6	B (LA)	3	74,5 x 76,4	999	4		48	65	21	
DFSB	D (A)	4	81 x 95,5	1968	4		110	150	289	
DFSC	D (A)	4	81 x 95,5	1968	4		55	75	289	
DFSD	D (A)	4	81 x 95,5	1968	4		75	102	289	
DFSE	D (A)	4	81 x 95,5	1968	4		90	122	289	
DFSF	D (A)	4	81 x 95,5	1968	4		55	75	289	
DG	B (NA)	4	94 x 68,9	1913	2	8,4	57	78	397	
DGCA Euro 6	D (LA)	4	81 x 95,5	1968	4	16,2	135	184	291	
DGDA Euro 6	D (LA)	4	79,5 x 80,5	1598	4	16,2	85	115	186	
DGDB Euro 6	D (LA)	4	79,5 x 80,5	1598	4	16,2	85	115	184	
DGEA Euro 6	B (LA)	4	74,5 x 80	1395	4		110	150	26	
DGTE Euro 6	D (LA)	4	79,5 x 80,5	1598	4	16,2	85	115	186	
DH	B (NA)	4	94 x 69	1913	2	8,4	60-62	82-84	397	
DJ	B (NA)	4	94 x 76	2109	2	10,5	82	112	398	
DJGA Euro 6	D (LA)	4	81 x 95,5	1968	4		135	184	291	
DJHA Euro 6	B (LA)	4	82,5 x 92,8	1984	4		228	310	335	
DJHB	B (LA)	4	82,5 x 92,8	1984	4		213	290	335	
DJHC	B (LA)	4	82,5 x 92,8	1984	4		206	280	335	
DJJA Euro 6	B (LA)	4	82,5 x 92,8	1984	4	9,3	215	292	335	
DJKA Euro 6	B (LA)	4	74,5 x 80	1395	4		110	150	26	
DKJA Euro 6	B (LA)	3	74,5 x 76,4	999	4	10,5	85	115	26	
DKLA	B (A)	3	74,5 x 76,4	999	4		70	95	26	
DKLB Euro 6	B (LA)	3	74,5 x 76,4	999	4		63	86	26	
DKRF Euro 6	B (LA)	3	74,5 x 76,4	999	4		85	115	26	
DKTA Euro 6	B (LA)	4	82,5 x 92,8	1984	4		169	230	342	
DKTB Euro 6	B (LA)	4	82,5 x 92,8	1984	4		180	245	326	
DKZA Euro 6	B (A)	4	82,5 x 92,8	1984	4	11,65	140	190	342	
DL	B (NA)	6	76,5 x 86,4	2384	2	8,1	66	90	47	
DLBA	B (A)	4	82,5 x 92,8	1984	4		180	245	335	
DLRA	B (LA)	4	82,5 x 92,8	1984	4	9,3	215	292	335	
DLRB	B (LA)	4	82,5 x 92,8	1984	4	9,3	200	272	335	
DMFA Euro 6	B (LA)	4	82,5 x 92,8	1984	4	9,6:1	180	245	326	
DNJA	B (LA)	4	82,5 x 92,8	1984	4		162	220	326	
DNUA Euro 6	B (A)	4	82,5 x 92,8	1984	4		200	272	335	
DNUC	B (A)	4	82,5 x 92,8	1984	4	9,3	213	290	342	
DS	B (NA)	4	81 x 86,4	1781	2	9	66	90	196	
DSGB Euro 6	B (LA)	3	74,5 x 76,4	999	4		59	80	21	
DSRA Euro 6	D (LA)	4	81 x 95,5	1968	4		110	150	292	
DSRB Euro 6	D (LA)	4	81 x 95,5	1968	4		110	150	292	
DT	B (NA)	4	81 x 77,4	1595	2	9	55	75	191	
DTA	B (NA)	4	81 x 77,4	1595	2	9:1	51-55	69-75	207	
DV	D (A)	6	76,5 x 86,4	2384	2	23	75-80	102-109	100	
DW	D (NA)	6	76,5 x 86,4	2383	2	23,5	55-57	75-78	101	
DX	B (NA)	4	81 x 86,4	1781	2	10	82	112	193	
DZ	B (NA)	4	81 x 86,4	1781	2	10	82	112	201	
EE	B (NA)	4	79,5 x 80	1588	2	8,2:1	60	82	126	
EF	B	4	79,5 x 80	1588	2	8,2:1	60	82	126	
EG	B (NA)	4	79,5 x 80	1588	2	9,5	81	110	128	
EH	B (NA)	4	79,5 x 73,4	1457	2	8,2	53-57	72-78	126	
EM	B (NA)	4	79,5 x 80	1588	2	8,2:1	55	75	127	
EN	B (NA)	4	79,5 x 86,4	1715	2	8,2	51-57	75-78	126	
EP	B (NA)	4	75 x 73,4	1297	2	9	44	60	30	
EU	B (NA)	4	75 x 73,4	1297	2	8,2	44	60	33	
EV	B (NA)	4	81 x 86,4	1781	2	10	82	112	193	
EW	B (NA)	4	81 x 77,4	1595	2	9	55	75	194	
EX	B (NA)	4	81 x 86,4	1781	2	9	66	90	200	
EZ	B (NA)	4	81 x 77,4	1595	2	9	55	75	194	
EZA	B (NA)	4	81 x 77,4	1595	2	9	51-55	70-75	214	
FA	B (NA)	4	69,5 x 72	1093	2	8	37	50	6	
FB	B (NA)	4	76,5 x 80	1470	2	9,7:1	48-55	65-75	46	
FD	B (NA)	4	76,5 x 80	1471	2	9,7	55-63	75-86	46	
FH	B (NA)	4	76,5 x 80	1471	2	8,2	51	70	46	
FJ	B (NA)	4	69,5 x 72	1093	2	9,7	38	52	6	
FK	B (NA)	4	76,5 x 80	1471	2	8,2:1	48-51	65-70	93	
FN	B (NA)	4	79,5 x 80	1588	2	8	53-57	71-78	126	
FP	B (NA)	4	79,5 x 80	1588	2	8,2	51-55	70-75	127	

V

			Cyl.	mm	cm <sup>3</sup>		Comp. Ratio	kW	PS	Pos
							ε			
FR	B (NA)	4	79,5 x 80	1588	2	8,2	63	85	127	
FS	B (NA)	4	79,5 x 80	1588	2	8,2	53	72	125	
FT	B (NA)	4	79,5 x 80	1588	2	8	51	70	126	
FV	B (NA)	4	79,5 x 80	1588	2	8:1	51	70	127	
FY	B (NA)	4	75 x 72	1272	2	8,2	40	55	31	
FZ	B (NA)	4	75 x 72	1272	2	8,2	44	60	31	
GD	B (NA)	4	94 x 71	1970	2	7,3:1	51	70	394	
GE	B (NA)	4	94 x 71	1970	2	7,3	51	70	394	
GF	B (NA)	4	75 x 72	1272	2	8,2	44	60	32	
GG	B (NA)	4	69,5 x 72	1093	2	9,7	37	50	6	
GH	B (NA)	4	79,5 x 73,4	1457	2	8,2:1	48	65	126	
GK	B (NA)	4	75 x 72	1272	2	10,7	55	75	35	
GL	B (NA)	4	75 x 59	1043	2	9,5	29	40	34	
GN	B (NA)	4	75 x 59	1043	2	9,5:1	33-37	45-50	36	
GU	B (NA)	4	81 x 86,4	1781	2	10	66	90	200	
GW	B (NA)	4	94 x 69	1913	2	8,6	66	90	397	
GX	B (NA)	4	81 x 86,4	1781	2	10	66	90	204	
GZ	B (NA)	4	81 x 86,4	1781	2	10	82	112	198	
H	B (NA)	4	83 x 69	1493	2	7,8:1	32-33	44-45	347	
HA	B (NA)	4	69,5 x 59	895	2	8	29	40	6	
HB	B (NA)	4	69,5 x 72	1093	2	8,2	37	50	6	
HC	B (NA)	4	69,5 x 72	1093	2	9,5	44	60	6	
HD	B (NA)	4	69,5 x 72	1093	2	8,2:1	38	52	7	
HH	B (NA)	4	75 x 72	1272	2	8,2	44	60	31	
HJ	B (NA)	4	75 x 72	1272	2	8,2	43	58	31	
HK	B (NA)	4	75 x 72	1272	2	9,5	40	55	35	
HM	AB (NA)	4	81 x 77,4	1595	2	9	53-60	72-82	258	
HN	B (NA)	4	81 x 77,4	1595	2	9	53-55	72-75	194	
HP	B (NA)	5	81 x 77,4	1994	2	10	85	115	197	
HS	B (NA)	6	76,5 x 86,4	2384	2		62	82	94	
HT	B (NA)	4	81 x 86,4	1781	2	10	74-77	100-104	208	
HV	B (NA)	4	81 x 86,4	1781	2	9	66	90	203	
HW	B (NA)	4	75 x 72	1272	2	9,5	37	50	36	
HY	B (NA)	5	81 x 86,4	2226	2	9,3	100	136	205	
HZ	B (NA)	4	75 x 59	1043	2	9,5	33-37	45-50	37	
ISB-250 Euro 1	D (LA)	6	102 x 120	5883	4		184-186	250-253	403	
ISF2.8	D (LA)	4	94 x 100	2776	4	16,9:1	80-120	109-163	400	
JB	B (NA)	4	79,5 x 73,4	1457	2	8,2	51	70	127	
JH	B (NA)	4	81 x 86,4	1781	2	10	66-75	90-102	195	
JK	D (NA)	4	76,5 x 86,4	1588	2	23,5	39-40	52-54	105	
JN	B (NA)	4	81 x 86,4	1781	2	10	66-76	90-103	196	
JP	D (NA)	4	76,5 x 86,4	1588	2	23,5	40	54	107	
JR	D (A)	4	76,5 x 86,4	1588	2	23	51	70	108	
JS	B (NA)	5	81 x 77,4	1994	2	10	85	115	197	
JT	B (NA)	5	81 x 86,4	2226	2	8,5	82-88	112-120	210	
JV	B (NA)	4	81 x 86,4	1781	2	9	66	90	196	
JX	D (A)	4	76,5 x 86,4	1588	2	23,5	51	70	109	
KR	B (NA)	4	81 x 86,4	1781	4	10	100-102	136-140	211	
KT	B (NA)	4	81 x 86,4	1781	2	10	82	112	192	
KV	B (NA)	5	81 x 86,4	2226	2	10	100	136	197	
KX	B (NA)	5	81 x 86,4	2226	2	8,5	82-88	112-120	206	
KY	D (NA)	4	79,5 x 86,4	1715	2	23	42	57	133	
L	B (NA)	4	83 x 69	1493	2		29-32	40-44	347	
ME	D (NA)	4	76,5 x 86,4	1588	2	23,5	37-40	50-55	106	
MF	D (A)	4	76,5 x 86,4	1588	2	23	51	70	106	
MH	B (NA)	4	75 x 72	1272	2	9,2	40	55	37	
MN	D (NA)	4	75 x 72	1272	2	22	33	44	43	
MV	B (NA)	4	94 x 76	2109	2	8,7	67-71	91-97	398	
NU	B (NA)	4	75 x 72	1272	2	9,2	37	50	37	
NZ	B (NA)	4	75 x 72	1272	2	9,2	40	55	29	
PB	B (NA)	4	81 x 86,4	1781	2	10	82	112	205	
PD	B (NA)	4	81 x 86,4	1781	2	9	49	67	224	
PF	B (NA)	4	81 x 86,4	1781	2	10	75-79	102-107	205	
PG	B (K)	4	81 x 86,4	1781	2	8	110-118	150-160	219	
PL	B (NA)	4	81 x 86,4	1781	4	10	92-95	125-129	211	
PN	B (NA)	4	81 x 77,4	1595	2	9	51	70	190	
PP	B (NA)	4	81 x 77,4	1595	2	8,1	51	70	213	
PY	B (K)	4	75 x 72	1272	2	8	83-85	113-115	38	
RA	D (LA)	4	76,5 x 86,4	1588	2	23	59	80	106	

		Cyl.		cm <sup>3</sup>		Comp. Ratio	ε	kW	PS	Pos
RD	B (NA)	4	81 x 86,4	1781	2	10	79	107	209	
RE	B (NA)	4	81 x 77,4	1595	2	9:1	53	72	212	
RF	B (NA)	4	81 x 77,4	1595	2	9	53	72	190	
RH	B (NA)	4	81 x 86,4	1781	2	10	62	84	215	
RL	B (NA)	4	81 x 77,4	1595	2	9	53	72	207	
RM	B (NA)	4	81 x 86,4	1781	2	10	63-64	87	202	
RP	B (NA)	4	81 x 86,4	1781	2	10	65-66	88-90	216	
RV	B (NA)	4	81 x 86,4	1781	2	10	75-77	102-105	205	
SB	D (LA)	4	76,5 x 86,4	1588	2	23	59	80	106	
SP	B (NA)	4	94 x 68,9	1913	2	8,7:1	54-68	73-92	399	
SR	B (NA)	4	94 x 76	2109	2	8,7	64	87	398	
SS	B (NA)	4	94 x 76	2109	2	8,7	68-70	92-95	398	
T	B (NA)	4	85,5 x 69	1584	2	7,5:1	40	54	376	
W	B (NA)	4	90 x 66	1679	2	8,2	59-63	80-86	389	
WN	B (NA)	5	79,5 x 77,4	1921	2	10	85	115	130	
WP	B (NA)	4	79,5 x 80	1588	2	8:1	48	65	127	
WT	B (NA)	4	79,5 x 86,4	1715	2	8,2:1	55-58	74-79	131	
WV	B (NA)	4	79,5 x 80	1588	2	8,2	55	75	131	
WY	B (NA)	4	79,5 x 80	1588	2	8,2	55	75	126	
WZ	B (NA)	4	79,5 x 80	1588	2	8,2	55	75	126	
YG	B (NA)	4	79,5 x 80	1588	2	8,2	61	83	125	
YH	AB (NA)	4	79,5 x 80	1588	2	8,2	57-61	77-83	132	
YJ	B (NA)	4	76,5 x 80	1471	2	9,7	55	75	46	
YP	B (NA)	4	79,5 x 80	1588	2	8,2	61-63	85	127	
YS	B (NA)	4	79,5 x 80	1588	2	9,5	81	110	129	
ZA	B (NA)	4	75 x 73,4	1297	2	8,5	40	55	30	
ZB	B (NA)	4	76,5 x 80	1471	2	9,7	55	75	46	
ZC	B (NA)	4	76,5 x 80	1471	2	9,7	57-63	85	46	
ZF	B (NA)	4	75 x 73,4	1297	2	8,5	44	60	30	



			Pos				Pos
<b>1500,1600 (31)</b>				<b>1.6 TDI</b> 10.2011 → 07.2016 CAYC D <b>181</b>			
1.6				1.8 TSI 12.2013 → 08.2016 CPKA B <b>328</b>			
1.6 TL 08.1965 → 07.1973 T B <b>376</b>				1.8 TSI 07.2016 → 07.2017 CPRA B <b>328</b>			
<b>1500,1600 Hatchback (31)</b>				2.0 TDI 04.2011 → 07.2016 CJAA D <b>272</b>			
1.6 TL 08.1965 → 07.1973 T B <b>376</b>				2.0 TDI 04.2012 → 07.2016 CFFB D <b>272</b>			
<b>1500,1600 Variant (36)</b>				2.0 TDI 06.2014 → 09.2018 CUUA D <b>289</b>			
1.6 09.1967 → 07.1973 T B <b>376</b>				2.0 TDI 12.2014 → 09.2018 CUUB D <b>289</b>			
1.6 L 08.1965 → 07.1973 T B <b>376</b>				2.0 TSI 04.2011 → 07.2016 CBFA B <b>310</b>			
<b>181</b>				2.0 TSI 04.2011 → 07.2016 CCTA B <b>310</b>			
1.5 09.1969 → 07.1970 H B <b>347</b>				2.0 TSI 07.2011 → 07.2016 CCZA B <b>313</b>			
<b>411,412</b>				2.0 TSI 12.2013 → 12.2016 CPPA B <b>324</b>			
1.7 09.1969 → 08.1973 W B <b>389</b>				2.0 TSI 12.2014 → 09.2018 CULC B <b>332</b>			
1.8 07.1973 → 03.1975 AN B <b>392</b>				2.0 TSI 07.2016 → 07.2019 CPLA B <b>323</b>			
1.8 07.1973 → 03.1975 AT B <b>392</b>				2.5 04.2011 → 07.2016 CBTA B <b>312</b>			
<b>412 Variant</b>				2.5 04.2011 → 07.2016 CBUA B <b>312</b>			
1.7 01.1972 → 12.1973 W B <b>389</b>				2.5 07.2016 → 07.2019 CCCA B <b>312</b>			
1.8 E,LE 07.1973 → 03.1975 AN B <b>392</b>				<b>BEETLE Convertible (5C7, 5C8)</b>			
1.8 E,LE 07.1973 → 03.1975 AT B <b>392</b>				1.2 TSI 12.2011 → 07.2019 CBZB B <b>8</b>			
<b>AMAROK (2HA, 2HB, S1B, S6B, S7A, S7B)</b>				1.2 TSI 16V 12.2014 → 07.2019 CYVD B <b>14</b>			
2.0 BiTDI 09.2010 → 08.2012 CDCA D <b>272</b>				1.4 TSI 12.2011 → 07.2016 CAVD B <b>73</b>			
2.0 BiTDI 11.2011 → CNEA D <b>272</b>				1.4 TSI 12.2011 → 07.2016 CNWA B <b>81</b>			
2.0 BiTDI 11.2011 → CSHA D <b>272</b>				1.4 TSI 12.2011 → 07.2016 CTHD B <b>80</b>			
2.0 BiTDI 4motion 09.2010 → 08.2012 CDCA D <b>272</b>				1.4 TSI 12.2014 → 09.2018 CZDA B <b>19</b>			
2.0 BiTDI 4motion 11.2011 → CNEA D <b>272</b>				1.6 TDI 12.2011 → 07.2016 CAYC D <b>181</b>			
2.0 BiTDI 4motion 11.2011 → CSHA D <b>272</b>				1.8 TSI 12.2013 → 12.2016 CPKA B <b>328</b>			
2.0 TDI 09.2010 → 10.2013 CDBA D <b>272</b>				1.8 TSI 12.2013 → 12.2016 CPRA B <b>328</b>			
2.0 TDI 09.2010 → 10.2013 CNFA D <b>272</b>				2.0 TDI 04.2012 → 07.2016 CFFB D <b>272</b>			
2.0 TDI 07.2012 → 10.2016 CNFB D <b>272</b>				2.0 TDI 04.2012 → 07.2016 CJAA D <b>272</b>			
2.0 TDI 4motion 09.2010 → 10.2013 CDBA D <b>272</b>				2.0 TDI 06.2014 → 09.2018 CUUA D <b>289</b>			
2.0 TDI 4motion 09.2010 → 10.2013 CNFA D <b>272</b>				2.0 TDI 09.2014 → 09.2018 CUUB D <b>289</b>			
2.0 TDI 4motion 06.2012 → 10.2016 CNFB D <b>272</b>				2.0 TSI 12.2011 → 07.2016 CBFA B <b>310</b>			
2.0 TSI 12.2010 → 10.2016 CFPA B <b>321</b>				2.0 TSI 12.2011 → 07.2016 CCTA B <b>310</b>			
2.0 TSI 4motion 09.2011 → 10.2016 CFPA B <b>321</b>				2.0 TSI 12.2011 → 07.2016 CCZA B <b>313</b>			
<b>AMEO (631)</b>				2.0 TSI 12.2012 → 07.2019 CPLA B <b>323</b>			
1.2 05.2016 → 01.2018 CJLA B <b>91</b>				2.0 TSI 12.2012 → 07.2019 CPPA B <b>324</b>			
<b>ARTEON (3H7, 3H8)</b>				2.0 TSI 01.2013 → 07.2016 CBFA B <b>310</b>			
2.0 TDI 03.2017 → 11.2019 DBGA D <b>289</b>				2.0 TSI 01.2013 → 07.2016 CCTA B <b>310</b>			
2.0 TDI 03.2017 → 11.2019 DFGA D <b>289</b>				2.0 TSI 12.2014 → 09.2018 CULC B <b>332</b>			
2.0 TDI 03.2017 → 11.2019 DSRB D <b>292</b>				2.5 12.2011 → 07.2016 CBTA B <b>312</b>			
2.0 TDI 03.2017 → 11.2019 DSRB D <b>292</b>				2.5 12.2011 → 07.2016 CBUA B <b>312</b>			
2.0 TDI 05.2017 → 06.2020 DFHA D <b>289</b>				2.5 12.2011 → 07.2016 CCCA B <b>312</b>			
2.0 TDI 11.2017 → 07.2020 CRGA D <b>289</b>				<b>BORA</b>			
2.0 TDI 4motion 05.2017 → 06.2020 DFHA D <b>289</b>				1.8 Turbo 09.2010 → AUQ B <b>243</b>			
2.0 TSI 05.2017 → CZPB B <b>342</b>				2.0 01.2007 → CBPA B <b>306</b>			
2.0 TSI 05.2017 → DKZA B <b>342</b>				2.0 Flex 02.2009 → 08.2010 CFEA AB <b>344</b>			
2.0 TSI 4motion 04.2017 → 06.2020 DJHC B <b>335</b>				2.0 Total Flex 02.2009 → 07.2010 CFEA AB <b>344</b>			
2.0 TSI 4motion 04.2018 → DLRB B <b>335</b>				<b>BORA (1J2/1J6)</b>			
2.0 TSI 4motion 04.2018 → DNUA B <b>335</b>				2.0 TDI 16V 05.2004 → 10.2010 BKD D <b>267</b>			
<b>ARTEON SHOOTING BRAKE (3H9)</b>				2.0 TDI 16V 07.2007 → 10.2010 CBEA D <b>278</b>			
2.0 TDI 09.2020 → DFHA D <b>289</b>				2.0 TSI 16V 06.2005 → 07.2009 BPY B <b>309</b>			
2.0 TDI 09.2020 → DSRB D <b>292</b>				2.0 TSI 16V 06.2005 → 12.2009 BWA B <b>309</b>			
2.0 TDI 09.2020 → DSRB D <b>292</b>				2.0 TSI 16V 07.2008 → 07.2009 CBFA B <b>310</b>			
2.0 TDI 4motion 09.2020 → DFHA D <b>289</b>				2.0 TSI 16V 07.2008 → 07.2009 CCTA B <b>310</b>			
2.0 TSI 4motion 06.2020 → DJHC B <b>335</b>				2.0 TSI 16V 07.2008 → 12.2009 CFEA AB <b>344</b>			
2.0 TSi 09.2020 → CZPB B <b>342</b>				2.5 FSI 20V 07.2007 → 10.2010 CBTA B <b>312</b>			
2.0 TSi 09.2020 → DKZA B <b>342</b>				2.5 SRE 20V 07.2007 → 10.2010 CBUA B <b>312</b>			
2.0 TSi 4motion 09.2020 → DLRB B <b>335</b>				2.5 SRE 20V 07.2007 → 10.2010 CCCA B <b>312</b>			
<b>ATLAS (CA1)</b>				2.5i 20V 01.2005 → 06.2007 BGP B <b>311</b>			
2.0 TSI 4motion 12.2017 → CXDA B <b>326</b>				2.5i 20V 01.2005 → 06.2007 BGQ B <b>312</b>			
<b>BEETLE (5C1, 5C2)</b>				2.5i 20V 06.2005 → 06.2007 BTK B <b>312</b>			
1.2 TSI 07.2011 → 07.2019 CBZB B <b>8</b>				2.5i 20V 07.2007 → 10.2010 CCCA B <b>312</b>			
1.2 TSI 16V 12.2014 → 07.2019 CYVD B <b>14</b>				<b>BORA I (1J2)</b>			
1.4 TSI 10.2011 → 09.2012 CNWA B <b>81</b>				1.4 16V 03.2000 → 05.2000 AKQ B <b>56</b>			
1.4 TSI 10.2011 → 07.2016 CAVD B <b>73</b>				1.4 16V 03.2000 → 05.2000 APE B <b>56</b>			
1.4 TSI 07.2012 → 07.2016 CTHD B <b>80</b>				1.4 16V 03.2000 → 05.2005 BCA B <b>57</b>			
1.4 TSI 07.2012 → 07.2016 CTKA B <b>81</b>				1.4 16V 05.2000 → 05.2005 AHW B <b>56</b>			
1.4 TSI 12.2014 → 07.2019 CZDA B <b>19</b>				1.4 16V 05.2000 → 05.2005 AXP B <b>57</b>			
				1.6 10.1998 → 05.2005 AEH B <b>235</b>			

			Pos				Pos		
1.6	10.1998 → 05.2005	AKL	B	235	1.6	08.2000 → 05.2005	BFQ	B	254
1.6	10.1998 → 05.2005	APF	B	235	1.6 16V	02.2000 → 05.2000	ATN	B	57
1.6	08.2000 → 05.2005	AVU	B	252	1.6 16V	02.2000 → 05.2005	BCB	B	57
1.6	08.2000 → 05.2005	BFQ	B	254	1.6 16V	05.2000 → 10.2000	AUS	B	57
1.6 16V	05.2000 → 10.2000	AUS	B	57	1.6 16V	09.2000 → 05.2005	AZD	B	62
1.6 16V	05.2000 → 05.2005	ATN	B	57	1.6 FSI	01.2002 → 05.2005	BAD	B	61
1.6 16V	05.2000 → 05.2005	BCB	B	57	1.8 4motion	05.1999 → 05.2005	AGN	B	242
1.6 16V	09.2000 → 05.2005	AZD	B	62	1.8 T	05.2000 → 05.2005	AGU	B	239
1.6 FSI	01.2002 → 05.2005	BAD	B	61	1.8 T	05.2000 → 05.2005	ARX	B	250
1.8	10.1998 → 05.2005	AGN	B	242	1.8 T	05.2000 → 05.2005	ARX	B	250
1.8	10.1998 → 05.2005	BAF	B	244	1.8 T	05.2002 → 05.2005	AUM	B	243
1.8 4motion	02.1999 → 05.2005	AGN	B	242	1.8 T	05.2002 → 05.2005	AUM	B	243
1.8 T	05.2000 → 05.2005	AGU	B	239	1.8 T	05.2002 → 05.2005	AWP	B	248
1.8 T	05.2000 → 05.2005	ARX	B	250	1.8 T	05.2002 → 05.2005	AWP	B	248
1.8 T	05.2000 → 05.2005	AUM	B	243	1.9 TDI	05.1999 → 06.2001	AHF	D	151
1.8 T	03.2002 → 05.2005	AUQ	B	243	1.9 TDI	05.1999 → 06.2001	AJM	D	156
1.8 T	03.2002 → 05.2005	AWP	B	248	1.9 TDI	05.1999 → 06.2001	AUY	D	157
1.8 T 4motion	10.2000 → 05.2001	ARX	B	250	1.9 TDI	05.2000 → 06.2001	ASV	D	150
1.9 SDI	10.1998 → 05.2005	AGP	D	155	1.9 TDI	05.2000 → 06.2001	ATD	D	156
1.9 SDI	10.1998 → 05.2005	AQM	D	147	1.9 TDI	09.2000 → 05.2005	ATD	D	156
1.9 TDI	10.1998 → 06.2001	AHF	D	151	1.9 TDI	09.2000 → 05.2005	AXR	D	161
1.9 TDI	10.1998 → 06.2001	ASV	D	150	1.9 TDI	09.2000 → 05.2005	BEW	D	163
1.9 TDI	10.1998 → 05.2005	AGR	D	151	1.9 TDI	11.2000 → 05.2005	ASZ	D	157
1.9 TDI	10.1998 → 05.2005	ALH	D	150	1.9 TDI	05.2001 → 05.2005	ARL	D	160
1.9 TDI	10.1998 → 05.2005	ALH	D	150	1.9 TDI	07.2004 → 05.2005	AGR	D	151
1.9 TDI	12.1998 → 01.2002	AJM	D	156	1.9 TDI	07.2004 → 05.2005	ALH	D	150
1.9 TDI	12.1998 → 01.2002	AUY	D	157	1.9 TDI 4motion	05.1999 → 05.2000	AJM	D	156
1.9 TDI	05.2000 → 05.2005	ARL	D	160	1.9 TDI 4motion	05.2000 → 06.2001	AUY	D	157
1.9 TDI	09.2000 → 05.2005	ATD	D	156	1.9 TDI 4motion	09.2000 → 05.2005	ATD	D	156
1.9 TDI	09.2000 → 05.2005	AXR	D	161	1.9 TDI 4motion	11.2000 → 05.2005	ASZ	D	157
1.9 TDI	09.2000 → 05.2005	BEW	D	163	1.9 TDI 4motion	05.2001 → 05.2005	ARL	D	160
1.9 TDI	11.2000 → 05.2005	ASZ	D	157	2.0	05.1999 → 05.2005	APK	B	305
1.9 TDI 4motion	11.1998 → 04.2002	AGR	D	151	2.0	05.1999 → 05.2005	AQY	B	305
1.9 TDI 4motion	02.1999 → 06.2001	AJM	D	156	2.0	05.1999 → 05.2005	AVH	B	306
1.9 TDI 4motion	02.1999 → 06.2001	AUY	D	157	2.0	05.1999 → 05.2005	AZH	B	305
1.9 TDI 4motion	05.2000 → 05.2005	ARL	D	160	2.0	05.1999 → 05.2005	AZJ	B	305
1.9 TDI 4motion	09.2000 → 05.2005	ATD	D	156	2.0	05.1999 → 05.2005	BEV	B	305
1.9 TDI 4motion	11.2000 → 05.2005	ASZ	D	157	2.0 4motion	04.2000 → 05.2005	AZH	B	305
2.0	10.1998 → 05.2000	APK	B	305	2.0 4motion	04.2000 → 05.2005	AZJ	B	305
2.0	10.1998 → 05.2000	AQY	B	305	2.3 V5	05.1999 → 10.2000	AGZ	B	238
2.0	10.1998 → 12.2013	AEG	B	304	2.3 V5	10.2000 → 05.2005	AQN	B	249
2.0	10.1998 → 12.2013	AVH	B	306	2.3 V5 4motion	05.1999 → 10.2000	AGZ	B	238
2.0	10.1998 → 12.2013	AZJ	B	305	2.3 V5 4motion	10.2000 → 05.2005	AQN	B	249
2.0	10.1998 → 12.2013	BER	B	305	2.8 V6 4motion	05.1999 → 05.2000	AQP	B	245
2.0	10.1998 → 12.2013	BEV	B	305	2.8 V6 4motion	05.1999 → 05.2005	BDE	B	246
2.0	10.1998 → 12.2013	BHP	B	305	2.8 V6 4motion	05.2000 → 05.2005	AUE	B	245
2.0	10.1998 → 12.2013	CBFA	B	306	<b>BRASILIA</b>				
2.0	10.1998 → 12.2013	CFEA	AB	344	1.3 Álcool	01.1980 → 12.1982	AB	B	120
2.0	04.2000 → 06.2001	AZH	B	305	1.6	10.1973 → 12.1982	AD	B	378
2.0	04.2000 → 12.2013	AZG	B	305	<b>CADDY ALLTRACK MPV (SAB)</b>				
2.0 4motion	04.2000 → 05.2005	AZJ	B	305	1.0 TSI	11.2015 →	CHZG	B	19
2.0 4motion	02.2001 → 05.2005	AZH	B	305	1.2 TSI	06.2015 →	CYVC	B	14
2.3 V5	10.1998 → 10.2000	AGZ	B	238	1.4 TGI CNG	06.2015 →	CPWA	BG	17
2.3 V5	10.2000 → 05.2005	AQN	B	249	1.4 TSI	05.2015 →	CZCB	B	19
2.3 V5 4motion	12.1998 → 10.2000	AGZ	B	238	1.6 TDI	05.2015 → 11.2017	CAYE	D	182
2.3 V5 4motion	10.2000 → 05.2005	AQN	B	249	1.6 TDI	05.2015 →	CAYD	D	181
2.8 V6 4motion	03.1999 → 05.2005	BDE	B	246	2.0 TDI	05.2015 →	CFHC	D	272
2.8 V6 4motion	05.1999 → 05.2000	AQP	B	245	2.0 TDI	05.2015 →	CLCA	D	272
2.8 V6 4motion	05.2000 → 05.2005	AUE	B	245	2.0 TDI	05.2015 →	CUUB	D	289
2.8 VR6	02.2002 → 07.2005	BDF	B	246	2.0 TDI	05.2015 →	CUUD	D	289
<b>BORA Variant (1J6)</b>					2.0 TDI	05.2015 →	CUUF	D	289
1.4 16V	09.2001 → 05.2005	AHW	B	56	2.0 TDI	05.2015 →	DFSB	D	289
1.4 16V	09.2001 → 05.2005	AKQ	B	56	2.0 TDI	05.2015 →	DFSD	D	289
1.4 16V	09.2001 → 05.2005	APE	B	56	2.0 TDI	05.2015 →	DFSF	D	289
1.4 16V	09.2001 → 05.2005	AXP	B	57	2.0 TDI 4motion	05.2015 → 05.2016	CFHF	D	272
1.4 16V	09.2001 → 05.2005	BCA	B	57	2.0 TDI 4motion	05.2015 →	CFHC	D	272
1.6	05.1999 → 09.2000	APF	B	235	2.0 TDI 4motion	05.2015 →	CUUE	D	289
1.6	05.1999 → 05.2005	AEH	B	235	2.0 TDI 4motion	05.2015 →	DFSE	D	289
1.6	05.1999 → 05.2005	AKL	B	235	2.0 TDI 4motion	11.2015 →	DFSB	D	289
1.6	08.2000 → 05.2005	AVU	B	252	<b>CADDY I (14)</b>				
					1.5	08.1982 → 07.1983	JB	B	127
					1.6	10.1982 → 10.1983	EM	B	127

V

			Pos				Pos		
1.6	01.1983 → 07.1992	EW	B	194	2.0 TDI	09.2015 → 09.2020	CLCA	D	272
1.6 D	08.1982 → 07.1992	CR	D	102	2.0 TDI	11.2015 → 09.2020	DFSB	D	289
1.6 D	08.1982 → 07.1992	JK	D	105	2.0 TDI	11.2015 → 09.2020	DFSD	D	289
1.6 D	08.1982 → 07.1992	ME	D	106	2.0 TDI	11.2015 → 09.2020	DFSF	D	289
1.7	01.1980 → 07.1984	EN	B	126	2.0 TDI 4motion	05.2015 → 11.2015	CUUE	D	289
1.8	11.1985 → 07.1992	JH	B	195	2.0 TDI 4motion	05.2015 → 09.2020	CFHC	D	272
<b>CADDY II (9K/9U)</b>					2.0 TDI 4motion	05.2015 → 09.2020	CFHF	D	272
1.8i	09.2002 → 06.2003	ADD	B	228	2.0 TDI 4motion	05.2015 → 09.2020	CLCA	D	272
<b>CADDY II MPV (9K9B)</b>					2.0 TDI 4motion	11.2015 → 09.2020	DFSB	D	289
1.4	11.1995 → 12.1997	AEX	B	49	2.0 TDI 4motion	11.2015 → 09.2020	DFSE	D	289
1.4	11.1997 → 09.2000	AKV	B	49	<b>CADDY LIFE (2K)</b>				
1.4	12.1997 → 06.2003	APQ	B	49	1.9 TDI	05.2004 → 08.2010	BLS	D	171
1.4	09.2000 → 06.2003	AUD	B	54	<b>CADDY MPV (6K9, 9E7, 9E9)</b>				
1.4 16V	08.2000 → 01.2004	AUA	B	56	1.8	09.2002 → 09.2005	ADD	B	228
1.6	11.1995 → 05.1997	1F	B	217	1.9 D	10.2005 → 06.2009	1Y	D	134
1.6	06.1997 → 09.2000	AEE	B	53	<b>CC B7 (358)</b>				
1.7 SDI	07.1996 → 09.2000	AHB	D	148	1.4 TSI	11.2011 → 12.2016	CTHD	B	80
1.9 D	11.1995 → 01.2004	1Y	D	134	1.4 TSI	05.2015 → 12.2016	CZDA	B	19
1.9 SDI	11.1995 → 01.2004	AEY	D	145	1.4 TSI MultiFuel	11.2011 → 12.2016	CKMA	AB	96
1.9 SDI	11.1995 → 01.2004	AYQ	D	147	1.8 TSI	11.2011 → 12.2016	CDAA	B	316
1.9 TDI	10.1996 → 01.2004	1Z	D	138	1.8 TSI	11.2011 → 12.2016	CDAB	B	319
1.9 TDI	10.1996 → 01.2004	AHU	D	140	2.0 TDI	11.2011 → 12.2016	CFFA	D	272
1.9 TDI	10.1996 → 01.2004	ALE	D	146	2.0 TDI	11.2011 → 12.2016	CFFB	D	272
1.9 TDI	10.1996 → 01.2004	ALH	D	150	2.0 TDI	11.2011 → 12.2016	CFGB	D	272
<b>CADDY II Pickup (9U7)</b>					2.0 TDI	11.2011 → 12.2016	CLLA	D	287
1.6	06.1996 → 12.2000	AEE	B	53	2.0 TDI	12.2012 → 12.2016	CFGC	D	272
1.9 D	06.1996 → 12.2000	AEF	D	144	2.0 TDI	05.2015 → 12.2016	CUVC	D	289
<b>CADDY III (2C/2K)</b>					2.0 TDI 4motion	11.2011 → 01.2013	CFGB	D	272
1.6	04.2004 → 05.2005	BGU	B	256	2.0 TDI 4motion	11.2011 → 12.2016	CFFB	D	272
1.8i	06.2003 → 09.2005	ADD	B	228	2.0 TDI 4motion	12.2012 → 12.2016	CFGC	D	272
<b>CADDY III MPV (2KB, 2KJ, 2CB, 2CJ)</b>					2.0 TSI	11.2011 → 12.2016	CBFA	B	310
1.2 TSI	09.2010 → 05.2015	CBZA	B	9	2.0 TSI	11.2011 → 12.2016	CCTA	B	310
1.2 TSI	09.2010 → 05.2015	CBZB	B	8	2.0 TSI	11.2011 → 12.2016	CCZB	B	313
1.4	03.2004 → 05.2006	BCA	B	57	3.6 FSI	11.2011 → 12.2016	BLV	B	385
1.4	05.2006 → 08.2010	BUD	B	75	3.6 FSI 4motion	11.2011 → 12.2016	BWS	B	385
1.6	04.2004 → 05.2015	BGU	B	256	3.6 FSI 4motion	11.2011 → 12.2016	CNNA	B	386
1.6	04.2004 → 05.2015	BSE	B	257	<b>CITI GOLF</b>				
1.6	04.2004 → 05.2015	BSF	B	257	1.3	01.1981 → 12.1984	EP	B	30
1.6 BiFuel	05.2011 → 05.2015	CHGA	BG	189	1.6	06.1996 → 12.1999	HM	AB	258
1.6 TDI	08.2010 → 05.2015	CAYD	D	181	<b>CORRADO (53I)</b>				
1.6 TDI	08.2010 → 05.2015	CAYE	D	182	1.8 16V	04.1989 → 07.1992	KR	B	211
1.9 D	10.2005 → 06.2009	1Y	D	134	1.8 G60	09.1988 → 09.1993	PG	B	219
1.9 TDI	04.2004 → 08.2010	BJB	D	169	2.0 i	04.1993 → 09.1994	2E	B	297
1.9 TDI	04.2004 → 08.2010	BLS	D	171	2.0 i	08.1993 → 07.1995	ADY	B	297
1.9 TDI	09.2005 → 08.2010	BSU	D	180	2.0 i 16V	08.1991 → 12.1995	9A	B	296
1.9 TDI 4motion	05.2008 → 08.2010	BLS	D	171	2.8 VR6	09.1991 → 12.1995	AAA	B	225
2.0 EcoFuel	04.2006 → 05.2015	BSX	BG	295	2.8i VR6 (USA)	08.1991 → 07.1995	AAA	B	225
2.0 SDI	03.2004 → 08.2010	BDJ	D	270	2.9 VR6	01.1994 → 12.1995	ABV	B	294
2.0 SDI	03.2004 → 08.2010	BST	D	270	<b>DASHER</b>				
2.0 TDI	09.2007 → 08.2010	BMM	D	271	1.5 D (USA)	08.1976 → 07.1981	CK	D	98
2.0 TDI	08.2010 → 05.2015	CLCA	D	272	1.6 (USA)	09.1975 → 11.1980	YG	B	125
2.0 TDI	05.2012 → 05.2015	CFJA	D	272	1.6 (USA)	09.1975 → 11.1980	YH	AB	132
2.0 TDI 16V	11.2010 → 05.2015	CFHC	D	272	1.6 D (USA)	03.1981 → 07.1982	CR	D	102
2.0 TDI 16V	11.2010 → 05.2015	CLCB	D	272	<b>DERBY (86)</b>				
2.0 TDI 16V 4motion	11.2010 → 05.2015	CFHC	D	272	0.9	02.1977 → 09.1981	HA	B	6
2.0 TDI 4motion	08.2010 → 05.2015	CFHF	D	272	1.1	02.1977 → 09.1981	HB	B	6
<b>CADDY IV MPV (SAB, SAJ)</b>					1.1	02.1977 → 09.1981	HD	B	7
1.0 TSI	11.2015 → 09.2020	CHZG	B	19	1.3	02.1977 → 09.1981	HH	B	31
1.2 TSI	06.2015 → 09.2020	CYVC	B	14	1.3	02.1977 → 09.1981	HJ	B	31
1.4 TGI CNG	06.2015 → 09.2020	CPWA	BG	17	<b>DERBY (86C, 80)</b>				
1.4 TSI	05.2015 → 09.2020	CZCB	B	19	1.0	10.1981 → 12.1984	GL	B	34
1.6	11.2015 → 09.2020	CWVA	B	92	1.1	10.1981 → 07.1983	HB	B	6
1.6 TDI	05.2015 → 11.2017	CAYE	D	182	1.3	08.1981 → 07.1983	HH	B	31
1.6 TDI	05.2015 → 09.2020	CAYD	D	181	1.3	09.1982 → 12.1984	GK	B	35
2.0 TDI	05.2015 → 11.2015	CUUB	D	289	1.3	08.1983 → 12.1984	HK	B	35
2.0 TDI	05.2015 → 11.2015	CUUD	D	289	1.3	08.1983 → 12.1984	HW	B	36
2.0 TDI	05.2015 → 11.2015	CUUF	D	289	<b>DERBY II (87)</b>				
2.0 TDI	05.2015 → 09.2020	CFHC	D	272	1.8i	10.1994 → 12.1994	ABS	B	226
2.0 TDI	05.2015 → 09.2020	CLCB	D	272	1.8i	10.1994 → 12.1994	ADZ	B	227

V

		Pos			Pos
1.8i 01.1995 → 11.1996	ADD B	228	1.6 TD	MF D	106
<b>DERBY III Saloon (6K2)</b>			1.6 TD	RA D	106
2.0 08.2000 → 12.2003	ADC B	299	1.6 TD	SB D	106
<b>EOS (1F7, 1F8)</b>			1.6i 16V 07.2008 →	CFZA B	67
1.4 TSI 11.2007 → 08.2015	CAXA B	78	1.8	GU B	200
1.4 TSI 05.2008 → 08.2015	CAVD B	73	1.8	RH B	215
1.4 TSI 05.2008 → 08.2015	CTHD B	80	1.8i 09.1994 →	AAM B	222
1.6 FSI 06.2006 → 05.2008	BLF B	69	1.8i 09.1994 →	ACC B	229
2.0 FSI 03.2006 → 05.2008	BVY B	308	1.8i 09.1994 →	ADZ B	227
2.0 FSI 03.2006 → 05.2008	BVZ B	308	1.8i 09.1994 →	PB B	205
2.0 TDI 06.2006 → 05.2008	BMM D	271	1.8i 09.1994 →	PF B	205
2.0 TDI 11.2010 → 08.2015	CFFA D	272	1.8i 09.1994 →	RP B	216
2.0 TDI 16V 05.2008 → 08.2015	CBAB D	272	1.8i 09.1994 →	RV B	205
2.0 TDI 16V 05.2008 → 08.2015	CFFB D	272	1.8i Turbo 16V 06.2003 →	AUQ B	243
2.0 TFSI 03.2006 → 08.2015	BPY B	309	1.9 D 06.2002 → 07.2006	1Y D	134
2.0 TFSI 03.2006 → 08.2015	BWA B	309	1.9 D 06.2002 → 07.2006	BGG D	168
2.0 TFSI 03.2006 → 08.2015	CAWB B	310	1.9 SDI	AEY D	145
2.0 TFSI 03.2006 → 08.2015	CBFA B	310	1.9 SDI	AGD D	145
2.0 TFSI 03.2006 → 08.2015	CCTA B	310	1.9 TD 06.1998 → 05.2002	AAZ D	137
2.0 TFSI 03.2006 → 08.2015	CCZA B	313	1.9 TD 06.1998 →	ABL D	139
2.0 TSI 11.2009 → 08.2015	CCZB B	313	1.9 TDI	AGR D	151
3.2 V6 06.2006 → 05.2009	BUB B	364	1.9 TDI	ALE D	146
3.2 V6 06.2006 → 05.2009	CBRA B	367	2.0i 16V 10.1995 →	ABF B	298
3.6 V6 05.2009 → 11.2010	CDVA B	388	2.8i VR6	AAA B	225
<b>FOX (5Z1/5Z3)</b>			<b>GOL I</b>		
1.3 09.1978 → 1981	HH B	31	1.3 Álcool 05.1980 → 09.1981	AB B	120
1.9 SDI 12.2007 →	ASY D	147	1.6 07.1985 → 10.1989	HM AB	258
<b>FOX (USA)</b>			1.6 07.1985 → 11.1994	HM AB	258
1.6 (USA) 01.1975 → 07.1980	YG B	125	1.8 05.1984 → 09.1994	RM B	202
1.6 (USA) 01.1975 → 07.1980	YH AB	132	<b>GOL II</b>		
1.8 (USA) 03.1987 → 06.1993	JN B	196	1.6 10.1995 → 02.1998	HM AB	258
<b>FOX Hatchback (5Z1, 5Z3, 5Z4)</b>			<b>GOL III</b>		
1.0 08.2003 → 12.2009	AQZ B	4	1.0 06.2002 → 09.2006	AZN B	4
1.0 04.2008 → 12.2009	CCNA B	4	1.9 D 06.2002 → 06.2006	1Y D	134
1.0 05.2009 → 12.2009	BNX B	4	1.9 D 06.2002 → 06.2006	BGG D	168
1.0 City Total Flex 11.2009 → 10.2014	BNX B	4	<b>GOL IV</b>		
1.0 Total Flex 08.2003 → 12.2009	AQZ B	4	1.0 02.2005 → 05.2010	BTY B	4
1.0 Total Flex 08.2003 → 12.2009	BJE AB	5	1.0 09.2005 → 05.2010	AZN B	4
1.0 Total Flex 03.2008 → 08.2014	CCNA B	4	1.0 City Total Flex 03.2005 → 07.2006	BTY B	4
1.2 04.2005 → 07.2011	BMD B	66	1.0 Flex 10.2005 → 12.2014	BNW AB	5
1.2 06.2009 → 07.2011	CHFB B	66	1.9 D 07.2005 → 12.2010	BGG D	168
1.2 09.2010 → 12.2011	CHFA B	66	<b>GOL V</b>		
1.4 TDI 04.2005 → 12.2009	BNM D	166	1.0 Flex 07.2008 →	CCNA B	4
1.6 10.2003 → 08.2014	BAH B	63	1.0 Álcool 05.2010 →	CCNA B	4
1.6 10.2003 → 08.2014	CFZA B	67	1.4 12.2010 → 06.2013	CNBA B	89
1.6 Rock in Rio Plus Total Flex 11.2009 → 10.2014	CCRA AB	95	1.6 07.2009 →	CCRA AB	95
1.6 Total Flex 10.2003 → 08.2014	CCRA AB	95	1.6 07.2009 →	CFZA B	67
1.9 D 12.2007 → 12.2009	ASY D	147	1.6 09.2009 →	CCRA AB	95
<b>FOX Hatchback (5Z5)</b>			1.6 09.2009 →	CFZA B	67
1.6 10.2015 →	CFZA B	67	1.6 16V Total Flex 06.2008 →	CCRA AB	95
1.6 Trendline Flex 08.2014 →	CCRA AB	95	1.6 Flex 07.2008 →	CCRA AB	95
<b>FOX Saloon</b>			1.6 Total Flex 07.2009 →	CCRA AB	95
1.6 01.1987 → 12.1993	HM AB	258	1.6 Total Flex 07.2009 →	CFZA B	67
1.8 01.1987 → 12.1990	JN B	196	<b>GOL VI</b>		
1.8 10.1990 → 12.1993	EV B	193	1.0 Flex 08.2012 → 12.2016	CCNA B	4
<b>FOX Variant</b>			1.6 08.2016 →	CFZA B	67
1.8 09.1986 → 12.1990	JN B	196	1.6 Flex 08.2012 →	CCRA AB	95
<b>GOL (BR)</b>			<b>GOL VII</b>		
1.0	ATE B	3	1.6 Flex 01.2016 →	CCRA AB	95
1.05	HZ B	37	<b>GOL VIII</b>		
1.3 01.1967 →	2G B	29	1.6 Total Flex 10.2018 →	CCRA AB	95
1.3i	NZ B	29	<b>GOLF ALLTRACK VII Variant (BA5, BV5)</b>		
1.4i	AEX B	49	1.6 TDI 4motion 12.2014 →	CRKB D	182
1.6 09.1975 →	RF B	190	1.6 TDI 4motion 12.2014 →	CXXB D	184
1.6 D	JP D	107	1.8 TSI 4motion 12.2014 →	CJSB B	339
1.6 D	ME D	106	1.8 TSI 4motion 08.2016 →	CXBB B	330
1.6 TD	1V D	114	2.0 TDI 4motion 12.2014 → 05.2018	CRBC D	278
1.6 TD	JR D	108	2.0 TDI 4motion 12.2014 → 05.2018	CRLB D	278
			2.0 TDI 4motion 12.2014 → 05.2018	DCYA D	289









				Pos					Pos
2.0 TDI 4motion	12.2014 →	CUNA	D	278	1.8	08.1984 → 05.1987	HV	B	203
2.0 TDI 4motion	12.2014 →	DGCA	D	291	1.8	08.1984 → 10.1987	GX	B	204
2.0 TDI 4motion	12.2014 →	DJGA	D	291	1.8	08.1984 → 10.1991	GU	B	200
TSI	02.2019 →	CJSB	B	339	1.8	08.1986 → 01.1990	RH	B	215
<b>GOLF I (17)</b>					1.8	09.1988 → 12.1992	PF	B	205
1.1	04.1974 → 07.1983	FA	B	6	1.8	09.1988 → 12.1992	RV	B	205
1.1	04.1974 → 07.1983	GG	B	6	1.8 GTI	08.1983 → 07.1984	DX	B	193
1.1	08.1976 → 07.1980	FJ	B	6	1.8 GTI	08.1983 → 04.1987	EV	B	193
1.3	08.1979 → 07.1983	GF	B	32	1.8 GTI	08.1983 → 10.1991	GZ	B	198
1.5	04.1974 → 12.1975	FH	B	46	1.8 GTI	01.1985 → 07.1985	HT	B	208
1.5	08.1977 → 07.1983	JB	B	127	1.8 GTI	01.1985 → 07.1985	RV	B	205
1.5 D	08.1976 → 07.1980	CK	D	98	1.8 GTI	08.1985 → 10.1987	RD	B	209
1.6	08.1975 → 07.1977	FT	B	126	1.8 GTI	01.1987 → 12.1987	PB	B	205
1.6	08.1975 → 02.1984	EM	B	127	1.8 GTI 16V	02.1986 → 06.1990	KR	B	211
1.6	08.1975 → 02.1984	FN	B	126	1.8 GTI 16V	02.1986 → 10.1991	PL	B	211
1.6	08.1975 → 02.1984	FP	B	127	1.8 GTI 16V	08.1986 → 07.1988	KR	B	211
1.6	09.1975 → 12.1980	FN	B	126	1.8 GTI Cat	01.1987 → 10.1991	PF	B	205
1.6	01.1983 → 02.1984	EW	B	194	1.8 GTI G60	04.1990 → 07.1991	PG	B	219
1.6	01.1983 → 02.1984	HN	B	194	1.8 GTI G60 Syncro	08.1988 → 03.1990	1H	B	218
1.6 D	08.1980 → 07.1982	CR	D	102	1.8 GTI G60 Syncro	04.1990 → 07.1991	PG	B	219
1.6 D	08.1982 → 07.1983	JK	D	105	1.8 Syncro	02.1986 → 07.1988	GX	B	204
1.6 GTI	08.1976 → 07.1982	EG	B	128	1.8 Syncro	02.1986 → 07.1991	GU	B	200
1.6 TD	03.1982 → 07.1983	CY	D	104	1.8 Syncro	08.1987 → 07.1988	RH	B	215
1.6 TD	08.1983 → 07.1985	JR	D	108	1.8 Syncro	08.1988 → 07.1991	1P	B	219
1.7	09.1980 → 12.1984	EN	B	126	1.8 i Cat	08.1987 → 10.1991	GX	B	204
1.8	09.1982 → 12.1984	JH	B	195	1.8 i Cat	08.1987 → 10.1991	RP	B	216
1.8 GTI	08.1982 → 12.1983	DX	B	193	1.8 i Cat Syncro	08.1987 → 10.1991	GX	B	204
<b>GOLF I Cabriolet (155)</b>					1.8 i Cat Syncro	08.1987 → 10.1991	RP	B	216
1.3	08.1983 → 07.1985	HK	B	35	2.0 GTI	09.1989 → 12.1992	9A	B	296
1.5	01.1979 → 11.1983	JB	B	127	<b>GOLF II (19E/1G1)</b>				
1.6	08.1979 → 07.1982	EG	B	128	1.3i	08.1985 → 07.1992	NZ	B	29
1.6	08.1979 → 07.1983	EM	B	127	2.0i 16V	08.1989 → 07.1991	9A	B	296
1.6	08.1983 → 04.1992	EW	B	194	<b>GOLF III (1H1)</b>				
1.6	08.1983 → 04.1992	HN	B	194	1.3	08.1991 → 07.1992	2G	B	29
1.6	04.1986 → 02.1990	RE	B	212	1.4	10.1991 → 07.1995	ABD	B	41
1.7	01.1980 → 07.1984	EN	B	126	1.4	11.1991 → 08.1997	ABD	B	41
1.8	08.1982 → 07.1984	DX	B	193	1.4	11.1991 → 08.1997	AEX	B	49
1.8	08.1982 → 12.1989	KT	B	192	1.4	07.1995 → 08.1997	AEX	B	49
1.8	08.1983 → 09.1992	EX	B	200	1.6	09.1992 → 09.1994	ABU	B	50
1.8	08.1983 → 12.1992	DX	B	193	1.6	10.1994 → 06.1995	AEA	B	52
1.8	01.1984 → 04.1987	EV	B	193	1.6	07.1995 → 12.1995	AEK	B	232
1.8	11.1985 → 12.1992	JH	B	195	1.6	07.1995 → 08.1997	AEE	B	53
1.8	01.1987 → 12.1987	PB	B	205	1.6	12.1995 → 08.1997	AFT	B	234
1.8	08.1989 → 03.1993	2H	B	220	1.6	05.1997 → 08.1997	AKS	B	241
<b>GOLF II (19E, 1G1)</b>					1.8	11.1991 → 09.1994	ABS	B	226
1.0	11.1983 → 08.1985	GN	B	36	1.8	11.1991 → 08.1997	AAM	B	222
1.0	08.1985 → 10.1991	HZ	B	37	1.8	11.1991 → 08.1997	ACC	B	229
1.3	08.1983 → 07.1985	HK	B	35	1.8	11.1991 → 08.1997	ADD	B	228
1.3	08.1983 → 06.1987	MH	B	37	1.8	10.1994 → 08.1997	ADZ	B	227
1.3	08.1985 → 12.1987	NU	B	37	1.8 Syncro (1HX1)	01.1993 → 09.1994	ABS	B	226
1.3 Cat	06.1986 → 12.1988	MH	B	37	1.8 Syncro (1HX1)	10.1994 → 08.1997	ADZ	B	227
1.3 Cat	02.1987 → 07.1992	NZ	B	29	1.9 D	11.1991 → 08.1997	1Y	D	134
1.3 Cat	08.1989 → 07.1992	2G	B	29	1.9 SDI	04.1997 → 08.1997	AEY	D	145
1.6	08.1983 → 07.1992	ABN	B	199	1.9 TD, GTD	11.1991 → 08.1997	AAZ	D	137
1.6	08.1983 → 07.1992	EZ	B	194	1.9 TDI	08.1993 → 08.1997	1Z	D	138
1.6	08.1983 → 07.1992	HM	AB	258	1.9 TDI	08.1993 → 08.1997	AHU	D	140
1.6	02.1986 → 10.1991	RF	B	190	1.9 TDI	04.1996 → 08.1997	AFN	D	140
1.6	08.1986 → 07.1991	EZA	B	214	1.9 TDI	11.1997 → 08.1997	ALE	D	146
1.6	08.1986 → 07.1991	PN	B	190	1.9 TDI Syncro (1HX1)	08.1995 → 08.1997	1Z	D	138
1.6	10.1986 → 12.1992	PN	B	190	1.9 TDI Syncro (1HX1)	08.1995 → 08.1997	AHU	D	140
1.6 D	08.1983 → 10.1991	JP	D	107	1.9 TDI Syncro (1HX1)	11.1997 → 08.1997	ALE	D	146
1.6 D	08.1983 → 10.1991	ME	D	106	2.0	11.1991 → 09.1994	2E	B	297
1.6 D	05.1988 → 10.1991	ME	D	106	2.0	11.1991 → 08.1997	ADC	B	299
1.6 TD	08.1983 → 07.1985	JR	D	108	2.0	10.1994 → 07.1995	ADY	B	297
1.6 TD	08.1983 → 10.1991	JR	D	108	2.0	07.1995 → 08.1997	AGG	B	301
1.6 TD	05.1988 → 10.1991	MF	D	106	2.0	05.1997 → 08.1997	AKR	B	303
1.6 TD	04.1989 → 10.1991	RA	D	106	2.0 GL	08.1995 → 09.1997	AEP	B	300
1.6 TD	04.1989 → 10.1991	SB	D	106	2.0 GTI 16V	08.1992 → 08.1997	ABF	B	298
1.6 TD	08.1989 → 10.1991	1V	D	114	2.0 Syncro (1HX1)	08.1995 → 08.1997	AGG	B	301

		Pos			Pos
2.8 VR6	01.1992 → 08.1997	AAA B 225	1.8 T	08.1997 → 06.2005	AGU B 239
2.8 VR6	08.1995 → 09.1997	AAA B 225	1.8 T	08.1997 → 06.2005	ARZ B 239
2.9 VR6 Syncro (1HX1)	10.1994 → 08.1997	ABV B 294	1.8 T	08.1997 → 06.2005	AUM B 243
<b>GOLF III Cabriolet (1E7)</b>			1.8 T	05.1998 → 04.2000	AQA B 239
1.6	10.1994 → 12.1995	AEK B 232	1.8 T GTI	08.2001 → 06.2005	AUQ B 243
1.6	12.1995 → 02.1998	AFT B 234	1.8 T GTI	08.2001 → 06.2005	AWP B 248
1.6	04.1997 → 02.1998	AKS B 241	1.9 SDI	08.1997 → 06.2005	AGP D 155
1.8	07.1993 → 07.1995	ABS B 226	1.9 SDI	08.1997 → 06.2005	AQM D 147
1.8	07.1993 → 05.1998	AAM B 222	1.9 TD	10.1997 → 09.1999	AAZ D 137
1.8	07.1995 → 05.1998	ADZ B 227	1.9 TDI	08.1997 → 05.2004	AHF D 151
1.9 TDI	08.1995 → 05.1998	IZ D 138	1.9 TDI	08.1997 → 05.2004	ASV D 150
1.9 TDI	08.1995 → 05.1998	AHU D 140	1.9 TDI	10.1997 → 05.2004	AGR D 151
1.9 TDI	08.1995 → 05.1998	ALE D 146	1.9 TDI	10.1997 → 05.2004	ALH D 150
1.9 TDI	07.1996 → 05.1998	AFN D 140	1.9 TDI	12.1998 → 06.2001	AJM D 156
2.0	07.1993 → 09.1994	2E B 297	1.9 TDI	12.1998 → 06.2001	AUY D 157
2.0	10.1994 → 07.1995	ADY B 297	1.9 TDI	05.2000 → 06.2005	ARL D 160
2.0	07.1995 → 05.1998	AGG B 301	1.9 TDI	09.2000 → 06.2005	ATD D 156
2.0	05.1997 → 05.1998	AKR B 303	1.9 TDI	09.2000 → 06.2005	AXR D 161
<b>GOLF III Variant (1H5)</b>			1.9 TDI	09.2000 → 06.2005	BEW D 163
1.4	07.1993 → 07.1995	ABD B 41	1.9 TDI	11.2000 → 06.2005	ASZ D 157
1.4	07.1993 → 04.1999	ABD B 41	1.9 TDI 4motion	07.1998 → 04.2002	AGR D 151
1.4	07.1993 → 04.1999	APQ B 49	1.9 TDI 4motion	09.1999 → 06.2001	AJM D 156
1.4	07.1995 → 04.1999	AEX B 49	1.9 TDI 4motion	09.1999 → 06.2001	AUY D 157
1.6	07.1994 → 12.1995	AEK B 232	1.9 TDI 4motion	02.2000 → 06.2005	ARL D 160
1.6	01.1996 → 04.1999	AFT B 234	1.9 TDI 4motion	09.2000 → 06.2005	ATD D 156
1.6	04.1997 → 04.1999	AKS B 241	1.9 TDI 4motion	11.2000 → 06.2005	ASZ D 157
1.8	07.1993 → 09.1994	ABS B 226	2.0	07.1998 → 05.2004	AEG B 304
1.8	07.1993 → 04.1999	AAM B 222	2.0	07.1998 → 05.2004	AQY B 305
1.8	07.1993 → 04.1999	ANN B 230	2.0	07.1998 → 05.2004	AVH B 306
1.8	07.1993 → 04.1999	ANP B 231	2.0	07.1998 → 05.2004	AZG B 305
1.8	10.1994 → 04.1999	ADZ B 227	2.0	07.1998 → 05.2004	AZJ B 305
1.8 Syncro	10.1994 → 04.1999	ADZ B 227	2.0	07.1998 → 05.2004	BER B 305
1.9 D	07.1993 → 04.1999	1Y D 134	2.0	07.1998 → 05.2004	BEV B 305
1.9 SDI	04.1997 → 04.1999	AEY D 145	2.0	08.1998 → 05.2004	APK B 305
1.9 TD	07.1993 → 04.1999	AAZ D 137	2.0 4motion	10.2000 → 06.2005	AZH B 305
1.9 TDI	03.1994 → 04.1999	IZ D 138	2.0 4motion	10.2000 → 06.2005	AZJ B 305
1.9 TDI	03.1994 → 04.1999	AHU D 140	2.0 BiFuel	05.2002 → 05.2003	BEH BG 295
1.9 TDI	04.1996 → 04.1999	AFN D 140	2.3 V5	08.1997 → 10.2000	AGZ B 238
1.9 TDI	05.1997 → 04.1999	ALE D 146	2.3 V5	10.2000 → 06.2005	AQN B 249
1.9 TDI Syncro	07.1995 → 04.1999	IZ D 138	2.3 V5 4motion	12.1998 → 10.2000	AGZ B 238
1.9 TDI Syncro	07.1995 → 04.1999	AHU D 140	2.3 V5 4motion	10.2000 → 06.2005	AQN B 249
1.9 TDI Syncro	07.1995 → 04.1999	ALE D 146	2.8 VR6	03.2002 → 06.2005	BDF B 246
2.0	07.1993 → 09.1994	2E B 297	2.8 VR6 4motion	03.1999 → 06.2005	AQP B 245
2.0	10.1994 → 07.1995	ADY B 297	2.8 VR6 4motion	03.1999 → 06.2005	AUE B 245
2.0	07.1995 → 04.1999	AGG B 301	2.8 VR6 4motion	03.1999 → 06.2005	BDE B 246
2.0	08.1995 → 04.1996	AEP B 300	3.2 R32 4motion	09.2002 → 06.2005	BFH B 365
2.0	05.1997 → 04.1999	AKR B 303	3.2 R32 4motion	09.2002 → 06.2005	BML B 364
2.0 Syncro	08.1995 → 04.1999	AGG B 301	<b>GOLF IV (9B3)</b>		
2.9 VR6 Syncro	10.1994 → 04.1999	ABV B 294	1.6	03.2007 → 12.2010	BAH B 63
<b>GOLF IV (1J1)</b>			1.6	03.2007 → 12.2010	CCRA AB 95
1.4 16V	10.1997 → 05.2004	AHW B 56	1.6	03.2007 → 12.2010	CFZA B 67
1.4 16V	10.1997 → 05.2004	AKQ B 56	1.6 Flex	05.2008 → 06.2014	CCRA AB 95
1.4 16V	10.1997 → 05.2004	APE B 56	1.6 Total Flex	03.2007 → 03.2014	BAH B 63
1.4 16V	10.1997 → 05.2004	AXP B 57	1.8 GTI	01.2007 → 12.2010	AUQ B 243
1.4 16V	10.1997 → 05.2004	BCA B 57	1.8 GTI	04.2007 → 05.2008	AUQ B 243
1.6	08.1997 → 05.2004	AKL B 235	2.0	01.2007 → 12.2010	BER B 305
1.6	08.1997 → 05.2004	APF B 235	2.0	01.2007 → 12.2010	BEV B 305
1.6	01.1998 → 05.2004	AEH B 235	2.0	01.2007 → 12.2010	BHP B 305
1.6	08.2000 → 06.2005	AVU B 252	2.0	01.2007 → 12.2010	CBPA B 306
1.6	08.2000 → 06.2005	BFQ B 254	2.0 Flex	06.2008 → 12.2014	CFEA AB 344
1.6	02.2001 → 03.2007	BAH B 63	<b>GOLF IV Cabriolet (1E7)</b>		
1.6 16V	02.2000 → 06.2005	ATN B 57	1.6	06.1998 → 06.2002	AFT B 234
1.6 16V	02.2000 → 06.2005	AUS B 57	1.6	06.1998 → 06.2002	AKS B 241
1.6 16V	02.2000 → 06.2005	AZD B 62	1.8	06.1998 → 06.2002	AAM B 222
1.6 16V	02.2000 → 06.2005	BCB B 57	1.8	06.1998 → 06.2002	ADZ B 227
1.6 FSI	01.2002 → 06.2005	BAD B 61	1.8	06.1998 → 06.2002	ANN B 230
1.6 Total Flex	02.2001 → 12.2007	BAH B 63	1.8	06.1998 → 06.2002	ANP B 231
1.8	08.1997 → 06.2005	AGN B 242	1.9 TDI	06.1998 → 06.2002	AFN D 140
1.8 4motion	05.1998 → 06.2005	AGN B 242	1.9 TDI	06.1998 → 06.2002	AHU D 140

V



 				Pos	 				Pos
1.9 TDI	06.1998 → 06.2002	ALE	D	146	1.4 FSI	07.2005 → 11.2006	BLN	B	71
1.9 TDI	06.1998 → 06.2002	AVG	D	149	1.4 TSI	05.2006 → 06.2008	BLG	B	72
2.0	06.1998 → 06.2002	AGG	B	301	1.4 TSI	05.2006 → 06.2008	BMV	B	72
2.0	06.1998 → 06.2002	AKR	B	303	1.4 TSI	06.2007 → 12.2013	CAXA	B	78
2.0	06.1998 → 06.2002	ATU	B	304	1.4 TSI	06.2008 → 12.2013	CAVD	B	73
2.0	06.1998 → 06.2002	AWF	B	304	1.4 TSI	06.2008 → 12.2013	CNWA	B	81
2.0	06.1998 → 06.2002	AWG	B	304	1.4 TSI	06.2008 → 12.2013	CTHD	B	80
<b>GOLF IV Variant (1J5)</b>					1.6	05.2005 → 12.2013	BSE	B	257
1.4 16V	05.1999 → 06.2006	AHW	B	56	1.6	05.2005 → 12.2013	BSF	B	257
1.4 16V	05.1999 → 06.2006	AKQ	B	56	1.6	05.2005 → 12.2013	CCSA	B	257
1.4 16V	05.1999 → 06.2006	APE	B	56	1.6	05.2005 → 12.2013	CMXA	B	254
1.4 16V	05.1999 → 06.2006	AXP	B	57	1.6 BiFuel	05.2009 → 12.2013	CHGA	BG	189
1.4 16V	05.1999 → 06.2006	BCA	B	57	1.6 FSI	12.2004 → 05.2008	BLF	B	69
1.6	05.1999 → 04.2002	AEH	B	235	1.6 MultiFuel	11.2007 → 12.2013	CCSA	B	257
1.6	05.1999 → 04.2002	AKL	B	235	1.6 MultiFuel	11.2007 → 12.2013	CMXA	B	254
1.6	05.1999 → 04.2002	APF	B	235	1.6 TDI	02.2009 → 12.2013	CAYB	D	181
1.6	08.2000 → 06.2006	AVU	B	252	1.6 TDI	03.2009 → 12.2013	CAYC	D	181
1.6	08.2000 → 06.2006	BFQ	B	254	1.9 TDI	01.2005 → 01.2009	BKC	D	161
1.6 16V	02.2000 → 06.2006	ATN	B	57	1.9 TDI	01.2005 → 01.2009	BLS	D	171
1.6 16V	02.2000 → 06.2006	AUS	B	57	1.9 TDI	01.2005 → 01.2009	BXE	D	161
1.6 16V	02.2000 → 06.2006	AZD	B	62	1.9 TDI	05.2005 → 12.2008	BRU	D	173
1.6 16V	02.2000 → 06.2006	BCB	B	57	1.9 TDI	05.2005 → 12.2008	BRX	D	174
1.6 FSI	01.2002 → 06.2006	BAD	B	61	1.9 TDI	05.2005 → 12.2008	BXJ	D	175
1.6 FSi	10.2003 → 07.2004	BAG	B	68	2.0 FSI	05.2005 → 06.2008	BLR	B	308
1.8 4motion	05.1999 → 06.2006	AGN	B	242	2.0 FSI	05.2005 → 06.2008	BLY	B	308
1.8 T	05.2000 → 06.2006	AGU	B	239	2.0 FSI	05.2005 → 06.2008	BVY	B	308
1.8 T	05.2000 → 06.2006	ARZ	B	239	2.0 FSI	05.2005 → 06.2008	BVZ	B	308
1.8 T	09.2000 → 06.2006	AUM	B	243	2.0 TDI	05.2005 → 12.2013	AZV	D	267
1.8 T	05.2002 → 06.2006	AUQ	B	243	2.0 TDI	05.2005 → 12.2013	CBDA	D	272
1.9 SDI	05.1999 → 06.2006	AGP	D	155	2.0 TDI	05.2005 → 12.2013	CFHB	D	274
1.9 SDI	05.1999 → 06.2006	AQM	D	147	2.0 TDI	12.2005 → 05.2011	BMM	D	271
1.9 TDI	05.1999 → 06.2001	AHF	D	151	2.0 TDI	01.2009 → 12.2013	CBDC	D	278
1.9 TDI	05.1999 → 06.2001	ASV	D	150	2.0 TDI	01.2009 → 12.2013	CLCA	D	272
1.9 TDI	05.1999 → 05.2006	AGR	D	151	2.0 TDI 16V	01.2005 → 12.2013	BKD	D	267
1.9 TDI	05.1999 → 05.2006	ALH	D	150	2.0 TDI 16V	01.2005 → 12.2013	CBDB	D	272
1.9 TDI	08.1999 → 06.2001	AJM	D	156	2.0 TDI 16V	01.2005 → 12.2013	CFHC	D	272
1.9 TDI	08.1999 → 06.2001	AUY	D	157	<b>GOLF SPORTSVAN VII (AM1, AN1)</b>				
1.9 TDI	09.2000 → 06.2006	ATD	D	156	1.0 TSI	05.2015 →	CHZD	B	27
1.9 TDI	09.2000 → 06.2006	AXR	D	161	1.0 TSI	05.2015 →	DKRF	B	26
1.9 TDI	11.2000 → 06.2006	ASZ	D	157	1.0 TSI	05.2017 →	CHZC	B	19
1.9 TDI	06.2001 → 06.2006	ARL	D	160	1.0 TSI	05.2017 →	CHZK	B	19
1.9 TDI 4motion	05.1999 → 06.2001	AJM	D	156	1.0 TSI	05.2017 →	DKLB	B	26
1.9 TDI 4motion	05.1999 → 04.2002	AGR	D	151	1.2 TSI	04.2014 →	CYVB	B	12
1.9 TDI 4motion	09.2000 → 06.2006	ATD	D	156	1.2 TSI	05.2014 →	CYVA	B	12
1.9 TDI 4motion	11.2000 → 06.2006	ASZ	D	157	1.4 TSI	02.2014 →	CZDA	B	19
1.9 TDI 4motion	05.2002 → 06.2005	ARL	D	160	1.4 TSI	04.2014 →	CZCA	B	19
2.0	05.1999 → 06.2006	APK	B	305	1.4 TSI MultiFuel	04.2014 →	CPVB	B	25
2.0	05.1999 → 06.2006	AQY	B	305	1.6	05.2014 →	CWVA	B	92
2.0	05.1999 → 06.2006	AZJ	B	305	1.6 TDI	02.2014 →	CRKA	D	182
2.0 4motion	10.2000 → 06.2006	AZH	B	305	1.6 TDI	02.2014 →	CRKB	D	182
2.0 4motion	10.2000 → 06.2006	AZJ	B	305	1.6 TDI	02.2014 →	CXXA	D	184
2.0 Bi-Fuel	02.2002 → 06.2006	BEH	BG	295	1.6 TDI	02.2014 →	CXXB	D	184
2.3 V5	05.1999 → 06.2006	AGZ	B	238	1.6 TDI	02.2014 →	DBKA	D	185
2.3 V5	10.2000 → 06.2006	AQN	B	249	1.6 TDI	02.2014 →	DDYB	D	186
2.3 V5 4motion	05.1999 → 06.2006	AGZ	B	238	1.6 TDI	11.2016 →	DDYA	D	186
2.3 V5 4motion	10.2000 → 06.2006	AQN	B	249	1.6 TDI	11.2016 →	DGTE	D	186
2.8 V6 4motion	05.1999 → 06.2006	AQP	B	245	2.0 TDI	02.2014 →	CRLB	D	278
2.8 V6 4motion	05.1999 → 06.2006	AUE	B	245	2.0 TDI	02.2014 →	DCYA	D	289
2.8 V6 4motion	05.1999 → 06.2006	BDE	B	246	2.0 TDI	02.2014 →	DFGA	D	289
<b>GOLF PLUS (5M1/521)</b>					2.0 TDI	05.2014 → 11.2017	CRVA	D	278
1.4 FSI 16V	05.2007 → 05.2011	BUD	B	75	2.0 TDI	05.2016 → 11.2017	CRLD	D	289
1.4 FSI 16V	07.2007 → 01.2014	CAXA	B	78	2.0 TDI	11.2016 → 11.2017	DCYB	D	289
1.9 SDI	12.2005 →	BGG	D	168	<b>GOLF V (1K1)</b>				
<b>GOLF PLUS V (5M1, 521)</b>					1.4 16V	10.2003 → 05.2006	BCA	B	57
1.2 TSI	11.2009 → 12.2013	CBZB	B	8	1.4 16V	05.2006 → 11.2008	BUD	B	75
1.2 TSI	05.2010 → 12.2013	CBZA	B	9	1.4 FSI	10.2003 → 07.2006	BKG	B	70
1.4 16V	01.2005 → 11.2006	BCA	B	57	1.4 FSI	10.2003 → 07.2006	BLN	B	71
1.4 16V	05.2006 → 12.2013	BUD	B	75	1.4 TSI	11.2005 → 11.2008	BLG	B	72
1.4 16V	05.2006 → 12.2013	CGGA	B	76	1.4 TSI	05.2006 → 11.2008	BMV	B	72

V

				Pos					Pos
1.4 TSI	05.2007 → 11.2008	CAXA	B	78	2.0 TDI	06.2007 → 07.2009	AZV	D	267
1.6	01.2004 → 11.2008	BGU	B	256	2.0 TDI	06.2007 → 07.2009	BMM	D	271
1.6	01.2004 → 11.2008	BSE	B	257	2.0 TDI	06.2007 → 07.2009	BVB	D	286
1.6	01.2004 → 11.2008	BSF	B	257	2.0 TDI 16V	06.2007 → 07.2009	BKD	D	267
1.6	01.2004 → 11.2008	CCSA	B	257	2.0 TDI 16V	06.2007 → 07.2009	CBDB	D	272
1.6 FSI	10.2003 → 07.2008	BAG	B	68	2.5	06.2007 → 07.2009	BTK	B	312
1.6 FSI	10.2003 → 07.2008	BLF	B	69	2.5	01.2008 → 07.2009	CCCA	B	312
1.6 FSI	10.2003 → 07.2008	BLP	B	69	<b>GOLF VI (5K1)</b>				
1.6 MultiFuel	10.2007 → 11.2008	CCSA	B	257	1.2 TSI	11.2008 → 11.2012	CBZB	B	8
1.8i 20V		BAF	B	244	1.2 TSI	05.2010 → 11.2012	CBZA	B	9
1.9 TDI	10.2003 → 11.2008	BKC	D	161	1.4	10.2008 → 11.2012	CGGA	B	76
1.9 TDI	10.2003 → 11.2008	BLS	D	171	1.4 TSI	10.2008 → 11.2012	CAVD	B	73
1.9 TDI	10.2003 → 11.2008	BXE	D	161	1.4 TSI	10.2008 → 11.2012	CAXA	B	78
1.9 TDI	05.2004 → 11.2008	BRU	D	173	1.4 TSI	10.2008 → 11.2012	CNWA	B	81
1.9 TDI	05.2004 → 11.2008	BXF	D	174	1.4 TSI	10.2008 → 11.2012	CTHD	B	80
1.9 TDI	05.2004 → 11.2008	BXJ	D	175	1.6	10.2008 → 11.2012	BSE	B	257
1.9 TDI 4motion	08.2004 → 11.2008	BKC	D	161	1.6	10.2008 → 11.2012	BSF	B	257
1.9 TDI 4motion	08.2004 → 11.2008	BLS	D	171	1.6	10.2008 → 11.2012	CCSA	B	257
1.9 TDI 4motion	08.2004 → 11.2008	BXE	D	161	1.6	10.2008 → 11.2012	CMXA	B	254
2.0	01.2005 → 11.2008	BEV	B	305	1.6 BiFuel	03.2009 → 11.2012	CHGA	BG	189
2.0	01.2005 → 11.2008	BHY	B	306	1.6 MultiFuel	10.2008 → 11.2012	CCSA	B	257
2.0 FSI	01.2004 → 11.2008	AXW	B	307	1.6 MultiFuel	10.2008 → 11.2012	CMXA	B	254
2.0 FSI	01.2004 → 11.2008	BLR	B	308	1.6 TDI	02.2009 → 11.2012	CAYB	D	181
2.0 FSI	01.2004 → 11.2008	BLX	B	308	1.6 TDI	02.2009 → 11.2012	CAYC	D	181
2.0 FSI	01.2004 → 11.2008	BLY	B	308	1.8 TSI	06.2009 → 01.2011	CDA A	B	316
2.0 FSI	01.2004 → 11.2008	BVX	B	308	2.0	09.2009 → 12.2010	BEV	B	305
2.0 FSI	01.2004 → 11.2008	BVY	B	308	2.0 GTI	01.2010 → 02.2014	CBFA	B	310
2.0 FSI	01.2004 → 11.2008	BVZ	B	308	2.0 GTI	01.2010 → 02.2014	CCTA	B	310
2.0 FSI 4motion	08.2004 → 11.2008	BLX	B	308	2.0 GTi	04.2009 → 11.2012	CCZB	B	313
2.0 FSI 4motion	08.2004 → 11.2008	BVX	B	308	2.0 GTi	06.2009 → 11.2013	CBFA	B	310
2.0 GTI	10.2004 → 02.2009	AXX	B	309	2.0 GTi	06.2009 → 11.2013	CCTA	B	310
2.0 GTI	10.2004 → 02.2009	BPY	B	309	2.0 GTi	06.2009 → 11.2013	CCZA	B	313
2.0 GTI	10.2004 → 02.2009	BWA	B	309	2.0 R 4motion	11.2009 → 05.2011	CDLA	B	320
2.0 GTI	10.2004 → 02.2009	CAWB	B	310	2.0 R 4motion	11.2009 → 11.2012	CDLF	B	314
2.0 GTI	10.2004 → 02.2009	CBFA	B	310	2.0 R 4motion	11.2009 → 11.2013	CDLC	B	314
2.0 GTI	10.2004 → 02.2009	CCTA	B	310	2.0 TDI	10.2008 → 11.2012	CBAA	D	272
2.0 GTI	09.2006 → 12.2008	BYD	B	314	2.0 TDI	10.2008 → 11.2012	CBDC	D	278
2.0 SDI	01.2004 → 11.2008	BDK	D	270	2.0 TDI	10.2008 → 11.2012	CFFA	D	272
2.0 TDI	10.2003 → 11.2008	AZV	D	267	2.0 TDI	10.2008 → 11.2012	CLCA	D	272
2.0 TDI	12.2004 → 11.2008	BMM	D	271	2.0 TDI	10.2008 → 05.2013	CBAB	D	272
2.0 TDI	11.2005 → 11.2008	BMN	D	276	2.0 TDI	10.2008 → 05.2013	CFFB	D	272
2.0 TDI 16V	10.2003 → 11.2008	BKD	D	267	2.0 TDI	10.2008 → 05.2013	CJAA	D	272
2.0 TDI 16V 4motion	08.2004 → 11.2008	BKD	D	267	2.0 TDI	04.2009 → 11.2012	CBBB	D	272
2.0 TDI 4motion	01.2007 → 11.2008	BMM	D	271	2.0 TDI	04.2009 → 11.2012	CFGB	D	272
2.5	01.2006 → 12.2008	BGP	B	311	2.0 TDI 4motion	05.2009 → 11.2012	CBAB	D	272
2.5	01.2006 → 12.2008	BGQ	B	312	2.0 TDI 4motion	05.2009 → 11.2012	CFFB	D	272
2.5	05.2007 → 11.2008	CBTA	B	312	2.5	07.2009 → 05.2013	CBTA	B	312
2.5	05.2007 → 11.2008	CBUA	B	312	2.5	07.2009 → 05.2013	CBUA	B	312
2.5 FSI 20V	05.2007 → 05.2008	CBTA	B	312	<b>GOLF VI Convertible (517)</b>				
2.5 SRE 20V	05.2007 → 11.2008	CBUA	B	312	1.2 TSI	03.2011 → 05.2016	CBZB	B	8
3.2 R32 4motion	11.2005 → 11.2008	BUB	B	364	1.2 TSI 16V	11.2013 → 05.2016	CJZA	B	13
3.2 R32 4motion	11.2005 → 11.2008	CBRA	B	367	1.2 TSI 16V	11.2013 → 05.2016	CYVD	B	14
<b>GOLF V Variant (1K5)</b>					1.4 TSI	03.2011 → 05.2016	CAVD	B	73
1.4	06.2007 → 07.2009	BUD	B	75	1.4 TSI	03.2011 → 05.2016	CNWA	B	81
1.4 TSI	06.2007 → 07.2009	BLG	B	72	1.4 TSI	03.2011 → 05.2016	CTHD	B	80
1.4 TSI	06.2007 → 07.2009	BMV	B	72	1.4 TSI	03.2011 → 05.2016	CTKA	B	81
1.4 TSI	06.2007 → 07.2009	CAXA	B	78	1.4 TSI	11.2011 → 05.2016	CAXA	B	78
1.4 TSI	07.2008 → 07.2009	CAVD	B	73	1.4 TSI	11.2013 → 05.2016	CHPB	B	22
1.6	06.2007 → 07.2009	BSE	B	257	1.4 TSI	11.2013 → 05.2016	CXSB	B	24
1.6	06.2007 → 07.2009	BSF	B	257	1.4 TSI	11.2013 → 05.2016	CZCA	B	19
1.6	06.2007 → 07.2009	CCSA	B	257	1.4 TSI	11.2013 → 05.2016	CZDA	B	19
1.6 MultiFuel	11.2007 → 07.2009	CCSA	B	257	1.6 TDI	03.2011 → 05.2016	CAYC	D	181
1.9 TDI	06.2007 → 07.2009	BLS	D	171	2.0 GTI	05.2012 → 05.2016	CCZB	B	313
1.9 TDI	06.2007 → 07.2009	BXE	D	161	2.0 R	01.2013 → 05.2016	CDLA	B	320
1.9 TDI 4motion	01.2008 → 07.2009	BLS	D	171	2.0 TDI	11.2011 → 05.2016	CFHC	D	272
2.0	06.2007 → 07.2009	BWA	B	309	2.0 TDI	11.2013 → 05.2016	CUUA	D	289
2.0	06.2007 → 07.2009	CAWB	B	310	2.0 TDI	11.2013 → 05.2016	CUUB	D	289
2.0	06.2007 → 07.2009	CBFA	B	310	2.0 TSI	11.2013 → 05.2016	CULC	B	332
2.0	06.2007 → 07.2009	CCTA	B	310	<b>GOLF VI Variant (AJ5)</b>				

V

			Pos				Pos		
1.2 TSI	07.2009 → 07.2013	CBZB	B	8	2.0 GTD	04.2013 →	DGCA	D	291
1.2 TSI	07.2010 → 07.2013	CBZA	B	9	2.0 GTD	04.2013 →	DJGA	D	291
1.4	07.2009 → 07.2013	BUD	B	75	2.0 GTD	11.2016 →	CRGA	D	289
1.4	07.2009 → 07.2013	CGGA	B	76	2.0 GTI	04.2013 →	CHHA	B	325
1.4 TSI	07.2009 → 07.2013	CAVD	B	73	2.0 GTI	04.2013 →	CHHB	B	325
1.4 TSI	07.2009 → 07.2013	CAXA	B	78	2.0 GTI	04.2013 →	CNTC	B	327
1.4 TSI	07.2009 → 07.2013	CNWA	B	81	2.0 GTI	04.2013 →	CXCB	B	326
1.4 TSI	07.2009 → 07.2013	CTHD	B	80	2.0 GTI	04.2013 →	CXDA	B	326
1.4 TSI	07.2009 → 07.2013	CTKA	B	81	2.0 GTI	11.2013 →	CNTA	B	335
1.6	07.2009 → 07.2013	BSE	B	257	2.0 GTI	11.2013 →	CXCA	B	326
1.6	07.2009 → 07.2013	BSF	B	257	2.0 GTI	03.2017 →	DKTB	B	326
1.6	07.2009 → 07.2013	CCSA	B	257	2.0 GTI	03.2017 →	DLBA	B	335
1.6 BiFuel	07.2009 → 12.2010	BSF	B	257	2.0 GTI Clubsport	02.2016 → 03.2017	CJXE	B	326
1.6 MultiFuel	07.2010 → 07.2013	CMXA	B	254	2.0 GTI Clubsport S	09.2016 →	CJXG	B	335
1.6 TDI	07.2009 → 07.2013	CAYC	D	181	2.0 GTI TCR	11.2018 →	DNUC	B	342
1.6 TDI	12.2009 → 07.2013	CAYB	D	181	2.0 R 360S 4motion	09.2016 →	CJXC	B	334
1.6 TDI 4motion	07.2009 → 07.2013	CAYC	D	181	2.0 R 4motion	11.2013 →	CJXB	B	333
2.0	01.2011 → 07.2014	CBPA	B	306	2.0 R 4motion	11.2013 →	CJXC	B	334
2.0 TDI	07.2009 → 07.2013	CBDA	D	272	2.0 R 4motion	11.2014 →	CYFB	B	336
2.0 TDI	07.2009 → 07.2013	CBDB	D	272	2.0 R 4motion	11.2014 →	DJJA	B	335
2.0 TDI	07.2009 → 07.2013	CFHB	D	274	2.0 R 4motion	11.2014 →	DLRA	B	335
2.0 TDI	07.2009 → 07.2013	CFHC	D	272	2.0 R 4motion	12.2016 →	CJXD	B	335
2.0 TDI	07.2009 → 07.2013	CJAA	D	272	2.0 R 4motion	12.2016 →	CJXG	B	335
2.0 TDI	01.2010 → 07.2013	CLCA	D	272	2.0 R 4motion	12.2016 →	DJHA	B	335
2.0 TSI	07.2009 → 07.2013	CCZA	B	313	2.0 R 4motion	12.2016 →	DJHB	B	335
2.5	07.2009 → 07.2014	CBTA	B	312	2.0 R 4motion	12.2016 →	DNUC	B	342
2.5	07.2009 → 07.2014	CBUA	B	312	2.0 TDI	08.2012 →	CRVC	D	290
2.5	07.2009 → 07.2014	CCCA	B	312	2.0 TDI	11.2012 → 07.2018	CRVA	D	278
<b>GOLF VII (5G1, BQ1, BE1, BE2)</b>					2.0 TDI	11.2012 →	CRBC	D	278
1.0 TSI	05.2015 →	CHZD	B	27	2.0 TDI	11.2012 →	CRLB	D	278
1.0 TSI	05.2015 →	DKRF	B	26	2.0 TDI	11.2012 →	CRMB	D	278
1.0 TSI	11.2016 →	CHZC	B	19	2.0 TDI	11.2012 →	DCYA	D	289
1.0 TSI	01.2017 → 07.2018	CHZK	B	19	2.0 TDI	11.2012 →	DFGA	D	289
1.0 TSI	01.2017 → 07.2018	DKLB	B	26	2.0 TDI	11.2014 → 07.2018	CYKB	D	289
1.2 TSI	08.2012 →	CJZB	B	11	2.0 TDI	11.2016 → 07.2018	DCYB	D	289
1.2 TSI	08.2012 →	CYVA	B	12	2.0 TDI	11.2018 →	DFGB	D	289
1.2 TSI	11.2012 →	CJZA	B	13	2.0 TDI 4motion	11.2012 →	CKFC	D	278
1.2 TSI	04.2014 →	CYVB	B	12	2.0 TDI 4motion	11.2012 →	CRBC	D	278
1.4 GTE HYBRID	07.2019 → 08.2020	DGEA	B	26	2.0 TDI 4motion	11.2012 →	CRLB	D	278
1.4 GTE Hybrid	05.2014 →	CUKB	B	19	2.0 TDI 4motion	11.2012 →	CRMB	D	278
1.4 GTE Hybrid	05.2014 →	DGEA	B	26	2.0 TDI 4motion	11.2012 →	DCYA	D	289
1.4 TGI CNG	06.2013 →	CPWA	BG	17	<b>GOLF VII Variant (BA5, BV5)</b>				
1.4 TSI	08.2012 →	CHPA	B	22	1.0 TSI	05.2015 → 03.2017	CHZD	B	27
1.4 TSI	08.2012 →	CPTA	B	23	1.0 TSI	05.2015 → 03.2017	DKRF	B	26
1.4 TSI	11.2012 →	CMBA	B	22	1.0 TSI	11.2016 →	CHZC	B	19
1.4 TSI	11.2012 →	CXSA	B	22	1.0 TSI	01.2017 → 07.2018	CHZK	B	19
1.4 TSI	05.2014 →	CZCA	B	19	1.0 TSI	07.2018 → 07.2018	DKLB	B	26
1.4 TSI	05.2014 →	CZDA	B	19	1.2 TSI	05.2013 → 03.2017	CJZB	B	11
1.4 TSI	05.2014 →	CZEA	B	21	1.2 TSI	05.2013 → 03.2017	CYVA	B	12
1.4 TSI MultiFuel	04.2013 →	CPVA	B	24	1.2 TSI	05.2013 →	CJZA	B	13
1.4 TSI MultiFuel	12.2013 →	CPVB	B	25	1.2 TSI	04.2014 →	CYVB	B	12
1.6	05.2014 →	CWVA	B	92	1.4 TGI CNG	09.2013 →	CPWA	BG	17
1.6 TDI	08.2012 →	CLHA	D	182	1.4 TSI	05.2013 → 03.2017	CHPA	B	22
1.6 TDI	01.2013 →	CRKB	D	182	1.4 TSI	05.2013 →	CXSA	B	22
1.6 TDI	01.2013 →	CXXB	D	184	1.4 TSI	05.2014 → 03.2017	CZCA	B	19
1.6 TDI	01.2013 →	DBKA	D	185	1.4 TSI	05.2014 → 03.2017	CZDD	B	19
1.6 TDI	04.2013 →	CLHB	D	182	1.4 TSI	05.2014 →	CHPB	B	22
1.6 TDI	04.2013 →	CRKA	D	182	1.4 TSI	05.2014 →	CZDA	B	19
1.6 TDI	04.2013 →	CXXA	D	184	1.4 TSI MultiFuel	04.2013 → 03.2017	CPVA	B	24
1.6 TDI	04.2013 →	DDYB	D	186	1.4 TSI MultiFuel	05.2014 → 03.2017	CPVB	B	25
1.6 TDI	11.2016 →	DDYA	D	186	1.6	05.2014 → 03.2017	CWVA	B	92
1.6 TDI	11.2016 →	DGTE	D	186	1.6 TDI	05.2013 → 03.2017	CLHA	D	182
1.6 TDI 4motion	11.2012 →	CLHA	D	182	1.6 TDI	05.2013 → 03.2017	CLHB	D	182
1.6 TDI 4motion	01.2013 →	CRKB	D	182	1.6 TDI	05.2013 → 03.2017	CRKA	D	182
1.6 TDI 4motion	01.2013 →	CXXB	D	184	1.6 TDI	05.2013 → 03.2017	CRKB	D	182
1.8 TSI	07.2013 →	CNSB	B	329	1.6 TDI	05.2013 → 03.2017	CXXA	D	184
1.8 TSI	07.2013 →	CXBA	B	330	1.6 TDI	05.2013 → 03.2017	CXXB	D	184
1.8 TSI	07.2013 →	CXBB	B	330	1.6 TDI	05.2013 → 03.2017	DBKA	D	185
2.0 GTD	04.2013 →	CUNA	D	278	1.6 TDI	05.2013 → 03.2017	DDYB	D	186

V

		Pos			Pos		
1.6 TDI	11.2016 →	DDYA D	186	1.3 Cat	06.1987 → 12.1988	MH B	37
1.6 TDI	11.2016 →	DGTE D	186	1.3 Cat	06.1987 → 12.1991	NZ B	29
1.6 TDI 4motion	05.2013 → 03.2017	CLHA D	182	1.3 Cat	08.1989 → 12.1991	2G B	29
1.6 TDI 4motion	05.2013 → 03.2017	CRKB D	182	1.6	01.1984 → 07.1992	ABN B	199
1.6 TDI 4motion	05.2013 → 03.2017	CXXB D	184	1.6	01.1984 → 07.1992	EZ B	194
1.8 TSI	07.2013 →	CNSB B	329	1.6	01.1984 → 07.1992	HM AB	258
1.8 TSI	07.2013 →	CXBA B	330	1.6	03.1986 → 10.1991	RF B	190
1.8 TSI	07.2013 →	CXBB B	330	1.6	10.1986 → 10.1991	PN B	190
1.8 TSI 4motion	11.2016 →	CJSB B	339	1.6 D	01.1984 → 10.1991	JP D	107
1.8 TSI 4motion	07.2017 →	CXBA B	330	1.6 D	05.1988 → 10.1991	ME D	106
1.8 TSI 4motion	07.2017 →	CXBB B	330	1.6 TD	01.1984 → 10.1991	JR D	108
2.0 GTD	01.2015 → 03.2017	CUNA D	278	1.6 TD	05.1988 → 10.1991	MF D	106
2.0 GTD	01.2015 → 03.2017	DGCA D	291	1.6 TD	04.1989 → 10.1991	RA D	106
2.0 GTD	01.2015 → 03.2017	DJGA D	291	1.6 TD	04.1989 → 10.1991	SB D	106
2.0 R 360S 4motion	09.2016 →	CJXC B	334	1.6 TD	01.1990 → 10.1991	1V D	114
2.0 R 4motion	03.2015 → 03.2017	CJXB B	333	1.7	08.1983 → 07.1985	EN B	126
2.0 R 4motion	03.2015 → 03.2017	CJXC B	334	1.8	01.1984 → 04.1987	EV B	193
2.0 R 4motion	12.2016 → 07.2018	CJXD B	335	1.8	01.1984 → 10.1991	GZ B	198
2.0 R 4motion	12.2016 → 07.2018	DJHB B	335	1.8	08.1984 → 05.1987	HV B	203
2.0 R 4motion	12.2016 →	CJXG B	335	1.8	08.1984 → 10.1987	GX B	204
2.0 R 4motion	12.2016 →	DJHA B	335	1.8	08.1984 → 07.1988	JH B	195
2.0 R 4motion	09.2018 → 07.2018	DNUC B	342	1.8	08.1984 → 10.1991	GU B	200
2.0 TDI	04.2013 →	CRBC D	278	1.8	01.1985 → 12.1992	HT B	208
2.0 TDI	04.2013 →	CRLB D	278	1.8	01.1985 → 12.1992	RV B	205
2.0 TDI	04.2013 →	DCYA D	289	1.8	08.1985 → 10.1987	RD B	209
2.0 TDI	04.2013 →	DFGA D	289	1.8	08.1986 → 01.1990	RH B	215
2.0 TDI	05.2013 → 03.2017	CRVA D	278	1.8	01.1987 → 12.1987	PB B	205
2.0 TDI	05.2015 → 03.2017	CYKB D	289	1.8 16V	08.1986 → 10.1991	PL B	211
2.0 TDI	11.2015 → 03.2017	CRLD D	289	1.8 16V	06.1987 → 12.1989	KR B	211
2.0 TDI	11.2016 → 03.2017	DCYB D	289	1.8 Cat	01.1987 → 10.1991	PF B	205
2.0 TDI	11.2018 → 03.2017	DFGB D	289	1.8 Cat	08.1987 → 10.1991	GX B	204
2.0 TDI 4motion	04.2013 → 05.2018	CRBC D	278	1.8 Cat	08.1987 → 10.1991	RP B	216
2.0 TDI 4motion	04.2013 → 05.2018	CRLB D	278	1.8 Syncro	08.1987 → 07.1988	RH B	215
2.0 TDI 4motion	04.2013 → 05.2018	DCYA D	289	1.8 Syncro	08.1987 → 12.1988	GU B	200
<b>GOLF VIII (CD1)</b>				1.8 Syncro	08.1987 → 12.1988	GX B	204
1.4 GTE PLUG-IN HYBRID	07.2020 →	DGEA B	26	1.8 Syncro	08.1987 → 12.1988	RP B	216
1.4 GTE Plug-in Hybrid	09.2020 →	DGEA B	26	1.8 Syncro	08.1988 → 07.1991	1P B	219
2.0 TDI	08.2019 →	DSRB D	292	2.0	08.1989 → 07.1992	9A B	296
<b>ILTIS (183)</b>				<b>JETTA III (1H5)</b>			
1.6 TD	08.1987 → 12.1988	1C D	110	1.8i	08.1992 → 01.1994	AAM B	222
<b>JETTA CITY Saloon</b>				1.8i	08.1992 → 07.1995	ACC B	229
2.0	09.2006 → 12.2009	BEV B	305	1.8i	02.1994 → 12.1998	ADD B	228
<b>JETTA CITY Variant</b>				1.9 TD	08.1992 → 12.1998	AAZ D	137
2.0	09.2006 → 12.2009	BEV B	305	1.9 TDI	08.1996 → 12.1998	AHU D	140
<b>JETTA I (16)</b>				2.0i	02.1994 → 12.1998	ADC B	299
1.1	08.1979 → 02.1984	GG B	6	2.8i VR6	07.1993 → 12.1998	AAA B	225
1.3	08.1979 → 02.1984	GF B	32	<b>JETTA III (1K2)</b>			
1.5	08.1978 → 02.1984	JB B	127	1.4 TSI	07.2006 → 10.2010	BLG B	72
1.5 D	08.1978 → 07.1980	CK D	98	1.4 TSI	07.2006 → 10.2010	BMV B	72
1.6	08.1978 → 02.1984	FR B	127	1.4 TSI	05.2007 → 10.2010	CAXA B	78
1.6	08.1981 → 07.1983	EM B	127	1.4 TSI	07.2008 → 10.2010	CAVD B	73
1.6	08.1982 → 07.1983	EW B	194	1.6	09.2004 → 10.2010	BGU B	256
1.6 D	08.1980 → 02.1984	CR D	102	1.6	09.2004 → 10.2010	BSE B	257
1.6 D	08.1982 → 02.1984	JK D	105	1.6	09.2004 → 10.2010	BSF B	257
1.6 GLI	08.1978 → 07.1982	EG B	128	1.6	09.2004 → 10.2010	CCSA B	257
1.6 TD	03.1982 → 02.1984	CY D	104	1.6 FSI	09.2005 → 10.2010	BLF B	69
1.7	08.1980 → 02.1984	EN B	126	1.6 MultiFuel	01.2008 → 10.2010	CCSA B	257
1.7	08.1980 → 12.1987	EN B	126	1.6 TDI	06.2009 → 10.2010	CAYC D	181
1.7	09.1980 → 02.1984	EN B	126	1.6 TDI	12.2009 → 10.2010	CAYB D	181
1.7	01.1981 → 12.1983	EN B	126	1.9 TDI	08.2005 → 10.2010	BKC D	161
1.8	08.1982 → 02.1984	DX B	193	1.9 TDI	08.2005 → 10.2010	BLS D	171
1.8	09.1983 → 02.1984	JH B	195	1.9 TDI	08.2005 → 10.2010	BRM D	179
<b>JETTA II (16E/19E/1G2)</b>				1.9 TDI	08.2005 → 10.2010	BXE D	161
1.05	08.1986 → 10.1991	HZ B	37	2.0	05.2005 → 10.2010	BEV B	305
1.3i	08.1985 → 07.1992	NZ B	29	2.0	05.2005 → 10.2010	BHY B	306
<b>JETTA II (19E, 1G2, 165)</b>				2.0 FSI	08.2005 → 10.2010	BLR B	308
1.3	01.1984 → 07.1985	HK B	35	2.0 FSI	08.2005 → 10.2010	BLX B	308
1.3	01.1984 → 06.1987	MH B	37	2.0 FSI	08.2005 → 10.2010	BLY B	308
				2.0 FSI	08.2005 → 10.2010	BVY B	308

V



			Pos				Pos		
2.0 FSI	08.2005 → 10.2010	BVZ	B	308	1.9 TDI	11.1998 → 06.2004	ALH	D	150
2.0 TDI	09.2005 → 10.2010	AZV	D	267	1.9 TDI	07.2003 → 01.2005	BEW	D	163
2.0 TDI	09.2005 → 10.2010	CBDA	D	272	2.0i	11.1998 → 01.2005	AEG	B	304
2.0 TDI	10.2005 → 10.2010	BMM	D	271	2.0i	06.2000 → 01.2005	APK	B	305
2.0 TDI	10.2006 → 10.2010	BMN	D	276	2.0i	06.2000 → 01.2005	AVH	B	306
2.0 TDI	10.2006 → 10.2010	CEGA	D	272	2.0i	06.2000 → 01.2005	AZG	B	305
2.0 TDI 16V	08.2005 → 10.2010	BKD	D	267	2.0i	04.2001 → 01.2005	BEJ	B	305
2.0 TDI 16V	08.2005 → 10.2010	CBDB	D	272	2.0i	04.2001 → 01.2005	BER	B	305
2.0 TDI 16V	08.2005 → 10.2010	CBEA	D	278	2.0i	04.2001 → 01.2005	BHP	B	305
2.0 TDI 16V	08.2005 → 10.2010	CJAA	D	272	2.0i	04.2001 → 05.2005	BEV	B	305
2.0 TFSI	10.2005 → 10.2010	AXX	B	309	2.8i VR6 24V	10.2001 → 01.2005	BDF	B	246
2.0 TFSI	10.2005 → 10.2010	BPY	B	309	<b>JETTA V (1K2)</b>				
2.0 TFSI	10.2005 → 10.2010	BWA	B	309	2.0 FTDI 16V	07.2008 →	CEGA	D	272
2.0 TFSI	10.2005 → 10.2010	CAWB	B	310	2.0i	01.2005 → 05.2007	BER	B	305
2.0 TFSI	10.2005 → 10.2010	CBFA	B	310	2.0i	01.2005 → 05.2007	BEV	B	305
2.0 TFSI	10.2005 → 10.2010	CCTA	B	310	2.0i	01.2005 → 05.2007	BHP	B	305
2.0 TFSI	07.2008 → 10.2010	CAWA	B	310	2.0i	01.2005 →	BHY	B	306
2.5	01.2006 → 10.2010	BGP	B	311	2.5 SRE 20V	07.2007 → 10.2010	CBTA	B	312
2.5	01.2006 → 10.2010	BGQ	B	312	2.5 SRE 20V	07.2007 → 10.2010	CBUA	B	312
2.5	01.2006 → 10.2010	BTK	B	312	<b>JETTA VI (162)</b>				
2.5	07.2008 → 10.2010	CBTA	B	312	2.5 SRE 20V	10.2010 →	CBTA	B	312
2.5	07.2008 → 10.2010	CBUA	B	312	2.5 SRE 20V	10.2010 →	CBUA	B	312
2.5	07.2008 → 10.2010	CCCA	B	312	<b>JETTA VII Saloon (BU3)</b>				
2.8 VR6	10.2009 → 10.2010	AAA	B	225	1.4 TSI	12.2017 →	CZDA	B	19
<b>JETTA IV (162, 163, AV3, AV2)</b>					<b>KAEFER</b>				
1.2 TSI	10.2010 →	CBZB	B	8	1200 L 1.6	08.1975 → 12.1977	AS	B	379
1.2 TSI 16V	08.2014 →	CYVD	B	14	1300 1.3 (11)	01.1965 → 07.1970	AC	B	118
1.4 TSI	04.2011 → 07.2014	CAVA	B	80	1300 1.3 (11)	01.1970 → 01.1973	AB	B	120
1.4 TSI	04.2011 → 07.2014	CTHA	B	81	1302 1.3	08.1970 → 07.1975	AC	B	118
1.4 TSI	04.2011 →	CAVD	B	73	1302 1.3 (11)	08.1970 → 08.1972	AB	B	120
1.4 TSI	04.2011 →	CTHD	B	80	1302 1.6 (11)	01.1970 → 01.1973	AD	B	378
1.4 TSI	05.2011 →	CAXA	B	78	1303 1.3 (13)	08.1972 → 08.1973	AB	B	120
1.4 TSI	05.2011 →	CMSB	B	82	1303 1.3 (13)	08.1973 → 07.1975	AR	B	119
1.4 TSI	08.2014 →	CZCA	B	19	1303 1.6 (13)	08.1972 → 12.1979	AD	B	378
1.4 TSI	08.2014 →	CZDA	B	19	1303 LS,S 1.6 (13)	08.1972 → 07.1973	AD	B	378
1.4 TSI	08.2014 →	CZTA	B	19	1303 LS,S 1.6 (13)	08.1973 → 12.1979	AJ	B	380
1.4 TSI Hybrid	04.2011 →	CNLA	B	19	1303 LS,S 1.6 (13)	08.1973 → 12.1979	AS	B	379
1.4 TSI Hybrid	04.2011 →	CRJA	B	19	1500 1.5 (11)	08.1966 → 11.1973	H	B	347
1.6	12.2011 →	CFNA	B	84	1500 1.5 (11)	09.1966 → 07.1970	L	B	347
1.6	12.2011 →	CLRA	B	88	1500 1.6	07.1970 → 01.1973	AD	B	378
1.6	03.2013 →	CFNB	B	88	1600	01.1984 → 10.1986	AF	B	377
1.6	09.2015 →	CWVA	B	92	1600 (Mexico)	05.1973 → 09.1992	AF	B	377
1.6 MPI	09.2015 → 04.2018	CWVB	B	92	<b>KAEFER Convertible (15)</b>				
1.6 TDI	04.2010 → 07.2015	CAYC	D	181	1.6	09.1975 → 12.1980	AJ	B	380
1.8 TSI	07.2014 →	CPKA	B	328	1302 1.3	08.1970 → 07.1974	AC	B	118
1.8 TSI	07.2014 →	CPRA	B	328	1302 1.6	08.1970 → 07.1974	AF	B	377
2.0	06.2010 → 12.2017	CBPA	B	306	1302,1303 1.6	07.1970 → 06.1979	AD	B	378
2.0 TDI	10.2010 →	CLCA	D	272	1303 1.3	07.1970 → 03.1981	AB	B	120
2.0 TDI	02.2011 →	CFFB	D	272	1500 1.5	01.1966 → 12.1970	H	B	347
2.0 TDI	02.2011 →	CFHC	D	272	1500 1.6	07.1969 → 07.1970	B	B	376
2.0 TDI	02.2011 →	CJAA	D	272	<b>KARMANN GHIA Convertible (14, 34)</b>				
2.0 TDI	02.2011 →	CLCB	D	272	1500	01.1966 → 12.1969	H	B	347
2.0 TDI	07.2014 →	CUUB	D	289	<b>KARMANN GHIA Coupe (14, 34)</b>				
2.0 TDI	08.2014 → 12.2017	CUUA	D	289	1300	07.1970 → 07.1974	AB	B	120
2.0 TSI	12.2010 →	CBFA	B	310	1500	01.1966 → 12.1969	H	B	347
2.0 TSI	12.2010 →	CCTA	B	310	1600	01.1970 → 12.1973	AD	B	378
2.0 TSI	12.2010 →	CCZA	B	313	1600	07.1971 → 07.1974	AD	B	378
2.0 TSI	12.2012 → 12.2017	CPLA	B	323	<b>KÄFER</b>				
2.0 TSI	12.2012 → 12.2017	CPPA	B	324	1.7 (USA)	08.1971 → 07.1973	CA	B	389
2.5	04.2010 →	CBTA	B	312	113	01.1960 → 1972	113 (34)	B	117
2.5	04.2010 →	CBUA	B	312	1200 1.3	08.1966 → 07.1975	AB	B	120
2.5	04.2010 →	CCCA	B	312	1200 1.3	08.1966 → 07.1975	AR	B	119
<b>JETTA IV (1J5)</b>					1200 1.6	08.1970 → 12.1977	AD	B	378
1.4i 16V	05.2000 → 04.2001	AXP	B	57	1200 1.6	08.1970 → 12.1977	AJ	B	380
1.8i Turbo 20V	06.2000 → 05.2005	AUQ	B	243	1200 1.6	08.1970 → 12.1977	AS	B	379
1.8i Turbo 20V	06.2000 →	AWP	B	248	1300 1.6	08.1970 → 07.1975	AD	B	378
1.8i Turbo 20V	12.2003 → 05.2005	AGU	B	239	1300 1.6	08.1970 → 07.1975	AJ	B	380
1.8i Turbo 20V	12.2003 → 05.2005	AUM	B	243	1300 1.6	08.1970 → 07.1975	AS	B	379
1.9 SDI	02.2002 →	AQM	D	147	<b>LOGUS (5X1)</b>				

V

		Pos			Pos
1.6 Álcool	04.1995 → 12.1996	YP B 127	1.9 TDI	06.2003 → 09.2010	BEW D 163
1.8	12.1992 → 05.1994	RM B 202	1.9 TDI	07.2005 → 09.2010	BSW D 178
1.8 Álcool	12.1992 → 05.1993	RM B 202	2.0	09.2002 → 10.2010	AZJ B 305
<b>LUPO I (6X1, 6E1)</b>			2.0	09.2002 → 10.2010	BDC B 305
1.0	09.1998 → 07.2005	AER B 1	2.0	09.2002 → 10.2010	BEV B 305
1.0	09.1998 → 07.2005	ALD B 2	2.0	09.2002 → 10.2010	BGD B 305
1.0	09.1998 → 07.2005	ALL B 1	2.5	07.2005 → 09.2010	BPR B 311
1.0	09.1998 → 07.2005	ANV B 2	2.5	07.2005 → 09.2010	BPS B 311
1.0	09.1998 → 07.2005	AUC B 2	<b>PARATI (BR)</b>		
1.2 TDI 3L	07.1999 → 11.2000	ANY D 116	1.9 D	08.1998 → 03.2006	1Y D 134
1.2 TDI 3L	11.2000 → 07.2005	AYZ D 116	1.9 D	06.2002 → 03.2006	BGG D 168
1.4	10.2000 → 07.2005	AUD B 54	<b>PARATI I Variant</b>		
1.4 16V	09.1998 → 07.2005	AHW B 56	1.6	06.1993 → 12.1995	FS B 125
1.4 16V	09.1998 → 07.2005	AKQ B 56	1.8	11.1989 → 12.1995	RM B 202
1.4 16V	05.1999 → 07.2005	APE B 56	1.8	08.1991 → 07.1994	RM B 202
1.4 16V	08.1999 → 07.2005	AFK B 58	<b>PARATI III Variant (5X5)</b>		
1.4 16V	08.1999 → 07.2005	ANM B 60	1.9 D	08.2002 →	1Y D 134
1.4 16V	08.1999 → 07.2005	AQQ B 58	1.9 D	08.2002 →	BGG D 168
1.4 16V	08.1999 → 07.2005	AUB B 58	<b>PARATI IV Variant (5W5)</b>		
1.4 16V	05.2000 → 07.2005	AUA B 56	1.4	12.2010 →	CNBA B 89
1.4 16V	04.2002 → 07.2005	BBY B 56	<b>PASSAT ALLTRACK B7 (365)</b>		
1.4 FSI	02.2001 → 07.2005	ARR B 61	1.8 TSI	01.2012 → 12.2014	CDAA B 316
1.4 TDI	01.1999 → 07.2005	AMF D 158	1.8 TSI	01.2012 → 12.2014	CDAB B 319
1.6 GTI	09.2000 → 07.2005	AVY B 61	2.0 TDI	01.2012 → 12.2014	CFFB D 272
1.7 SDI	09.1998 → 07.2005	AKU D 148	2.0 TDI 4motion	01.2012 → 12.2014	CFFB D 272
<b>MAXI (BR)</b>			2.0 TDI 4motion	01.2012 → 12.2014	CFGB D 272
1.6i	11.2007 → 08.2010	BSE B 257	2.0 TDI 4motion	01.2013 → 12.2014	CFGC D 272
1.6i	11.2007 → 08.2010	BSF B 257	2.0 TSI 4motion	01.2012 → 12.2014	CCZB B 313
1.9 TDI	11.2007 → 08.2010	BJB D 169	<b>PASSAT ALLTRACK B8 Variant (3G5, CB5)</b>		
1.9 TDI	11.2007 → 08.2010	BLS D 171	1.4 TSI 4motion	05.2015 →	CZEA B 21
2.0 TDI	11.2007 → 08.2010	BMM D 271	2.0 TDI 4motion	05.2015 → 11.2017	CRLB D 278
2.0i EcoFuel	04.2006 → 08.2010	BSX BG 295	2.0 TDI 4motion	05.2015 → 11.2017	DFEA D 289
<b>NEW BEETLE (9C1, 1C1)</b>			2.0 TDI 4motion	05.2015 →	DDAA D 291
1.4	11.2001 → 09.2010	BCA B 57	2.0 TDI 4motion	05.2015 →	DFCA D 289
1.6	10.1999 → 09.2000	AWH B 235	2.0 TDI 4motion	05.2015 →	DFHA D 289
1.6	06.2000 → 09.2010	AYD B 252	2.0 TSI 4motion	07.2015 →	CHHB B 325
1.6	06.2000 → 09.2010	BFS B 253	2.0 TSI 4motion	08.2018 →	DNUA B 335
1.8 T	10.1999 → 06.2000	APH B 239	2.0 TSI 4motion	11.2018 →	CJXA B 326
1.8 T	10.1999 → 09.2010	AGU B 239	<b>PASSAT B1 (32)</b>		
1.8 T	10.1999 → 09.2010	BKF B 248	1.3	05.1973 → 01.1978	ZA B 30
1.8 T	06.2000 → 10.2000	AVC B 251	1.3	05.1973 → 01.1978	ZF B 30
1.8 T	06.2000 → 09.2010	AWV B 243	1.3	01.1978 → 07.1980	FY B 31
1.8 T	10.2000 → 09.2010	AWU B 243	1.3	01.1978 → 07.1980	FZ B 31
1.8 T	11.2001 → 06.2005	AWP B 248	1.5	05.1973 → 12.1975	ZC B 46
1.8 T	07.2004 → 06.2005	BNU B 248	1.5	07.1973 → 07.1974	ZB B 46
1.9 TDI	01.1998 → 06.2004	ALH D 150	1.5	08.1974 → 12.1975	YJ B 46
1.9 TDI	06.2001 → 09.2010	ATD D 156	1.5 D	08.1977 → 07.1980	CK D 98
1.9 TDI	07.2005 → 12.2006	BEW D 163	1.6	08.1975 → 07.1980	FS B 125
1.9 TDI	07.2005 → 09.2010	AXR D 161	1.6	08.1975 → 07.1980	YP B 127
1.9 TDI	07.2005 → 09.2010	BSW D 178	1.6	08.1975 → 11.1980	YG B 125
2.0	01.1998 → 09.2010	AEG B 304	1.6	08.1975 → 11.1980	YH AB 132
2.0	01.1998 → 09.2010	AQY B 305	1.6	08.1979 → 07.1980	WY B 126
2.0	01.1998 → 09.2010	AZG B 305	1.6	08.1979 → 07.1980	WZ B 126
2.0	01.1998 → 09.2010	AZJ B 305	1.6 D	09.1980 → 07.1981	CR D 102
2.0	01.1998 → 09.2010	BER B 305	1.6 GLi	06.1978 → 07.1980	YS B 129
2.0	01.1998 → 09.2010	BEV B 305	<b>PASSAT B1 Saloon (32)</b>		
2.0	03.2000 → 09.2010	APK B 305	1.5 D	10.1979 → 12.1982	CK D 98
2.3 V5	10.2000 → 09.2010	AQN B 249	<b>PASSAT B1 Variant (33)</b>		
2.5	07.2005 → 09.2010	BPR B 311	1.3	05.1973 → 01.1978	ZA B 30
2.5	07.2005 → 09.2010	BPS B 311	1.3	10.1973 → 01.1978	ZF B 30
3.2 RSI 4motion (1C9)	04.2000 → 05.2001	AXJ B 362	1.3	01.1978 → 07.1980	FY B 31
<b>NEW BEETLE Convertible (1Y7)</b>			1.5	10.1973 → 07.1974	ZB B 46
1.4	01.2003 → 09.2010	BCA B 57	1.5	10.1973 → 12.1975	ZC B 46
1.6	01.2003 → 09.2010	BFS B 253	1.5	08.1974 → 08.1975	YJ B 46
1.8 T	01.2003 → 09.2010	AWU B 243	1.5 D	02.1977 → 07.1980	CK D 98
1.8 T	01.2003 → 09.2010	AWV B 243	1.6	08.1975 → 07.1980	YP B 127
1.8 T	01.2003 → 09.2010	BKF B 248	1.6	08.1975 → 11.1980	YG B 125
1.9 TDI	09.2002 → 06.2004	ALH D 150	1.6	08.1975 → 11.1980	YH AB 132
1.9 TDI	06.2003 → 09.2010	AXR D 161	1.6	02.1976 → 08.1979	FS B 125



				Pos					Pos
1.6 D	02.1979 → 07.1980	CR	D	102	1.9	01.1981 → 07.1983	WN	B	130
1.6 i	06.1978 → 07.1980	YS	B	129	2.0	08.1983 → 03.1988	HP	B	197
<b>PASSAT B2 (32B)</b>					2.0	08.1983 → 03.1988	JS	B	197
1.3	08.1980 → 07.1983	FY	B	31	2.0 Syncro	05.1984 → 03.1988	JS	B	197
1.3	08.1980 → 07.1983	FZ	B	31	2.2	01.1985 → 03.1988	KV	B	197
1.3	08.1980 → 07.1986	EP	B	30	2.2	08.1985 → 03.1988	KX	B	206
1.3	08.1980 → 07.1986	EU	B	33	2.2 Syncro	08.1984 → 07.1988	HY	B	205
1.6	09.1979 → 11.1980	WY	B	126	2.2 Syncro	08.1985 → 03.1988	JT	B	210
1.6	08.1980 → 03.1988	DT	B	191	2.2 Syncro	08.1985 → 03.1988	KX	B	206
1.6	01.1981 → 02.1983	YP	B	127	2.2 Syncro	09.1985 → 12.1988	KX	B	206
1.6	08.1981 → 07.1983	WV	B	131	<b>PASSAT B3 (35l)</b>				
1.6	02.1986 → 03.1988	RL	B	207	1.6	04.1988 → 07.1989	RF	B	190
1.6	08.1986 → 03.1988	DTA	B	207	1.9 TD	03.1991 → 09.1993	AAZ	D	137
1.6	08.1986 → 03.1988	PP	B	213	2.0i	03.1990 → 09.1983	2E	B	297
1.6 D	08.1980 → 07.1982	CR	D	102	2.0i	08.1991 → 09.1983	ACX	B	297
1.6 D	08.1982 → 03.1988	JK	D	105	<b>PASSAT B3/B4 (3A2, 35l)</b>				
1.6 TD	04.1982 → 03.1988	CY	D	104	1.6	04.1988 → 07.1989	RF	B	190
1.6 TD	05.1986 → 03.1988	RA	D	106	1.6	04.1988 → 07.1991	EZ	B	194
1.7	09.1981 → 12.1983	WT	B	131	1.6	08.1988 → 07.1990	1F	B	217
1.8	01.1983 → 03.1988	DS	B	196	1.6	08.1991 → 07.1992	ABN	B	199
1.8	01.1983 → 03.1988	JV	B	196	1.6	10.1994 → 12.1995	AEK	B	232
1.8	08.1983 → 03.1988	JN	B	196	1.6	12.1995 → 08.1996	AFT	B	234
1.8	12.1983 → 03.1988	DZ	B	201	1.6 TD	08.1988 → 07.1989	RA	D	106
1.8	05.1986 → 03.1988	RM	B	202	1.6 TD	08.1989 → 09.1993	SB	D	106
1.9	01.1981 → 07.1983	WN	B	130	1.8	02.1988 → 07.1991	RP	B	216
2.0	08.1983 → 03.1988	HP	B	197	1.8	04.1988 → 10.1991	PF	B	205
2.0	08.1983 → 03.1988	JS	B	197	1.8	04.1988 → 07.1992	PB	B	205
2.2	01.1985 → 03.1988	KV	B	197	1.8	08.1990 → 08.1996	AAM	B	222
2.2	08.1985 → 12.1986	KX	B	206	1.8	08.1991 → 09.1994	ABS	B	226
2.2	08.1985 → 03.1988	KX	B	206	1.8	08.1994 → 08.1996	ADZ	B	227
<b>PASSAT B2 Saloon (32B)</b>					1.8 16V	04.1988 → 12.1989	KR	B	211
1.6	08.1984 → 03.1988	DT	B	191	1.8 G60	08.1991 → 10.1993	PG	B	219
1.6	01.1985 → 03.1988	RL	B	207	1.8 G60 Syncro	08.1988 → 08.1996	PG	B	219
1.6	08.1986 → 03.1988	DTA	B	207	1.8 GL	08.1991 → 09.1993	KR	B	211
1.6	03.1987 → 03.1988	PP	B	213	1.9 D	05.1989 → 10.1993	1Y	D	134
1.6 D	08.1984 → 03.1988	JK	D	105	1.9 TD	03.1991 → 08.1996	AAZ	D	137
1.6 TD	01.1985 → 03.1988	CY	D	104	1.9 TDI	10.1993 → 07.1996	1Z	D	138
1.8	08.1984 → 12.1985	JN	B	196	1.9 TDI	10.1993 → 08.1996	AHU	D	140
1.8	08.1984 → 06.1989	DS	B	196	1.9 TDI	03.1996 → 08.1996	AFN	D	140
1.8	01.1985 → 03.1988	DS	B	196	2.0	11.1991 → 09.1994	2E	B	297
1.8	01.1985 → 03.1988	JN	B	196	2.0	10.1994 → 07.1995	ADY	B	297
1.8	05.1986 → 03.1988	RM	B	202	2.0	03.1995 → 08.1996	AEP	B	300
2.0	08.1984 → 07.1985	HP	B	197	2.0	07.1995 → 08.1996	AGG	B	301
2.0	08.1984 → 07.1985	JS	B	197	2.0 16V	08.1988 → 09.1993	9A	B	296
2.2	01.1985 → 03.1988	KX	B	206	2.0 16V	01.1994 → 08.1996	ABF	B	298
2.2	08.1985 → 12.1988	KX	B	206	2.0 Syncro	11.1991 → 09.1994	2E	B	297
<b>PASSAT B2 Variant (33B)</b>					2.0 Syncro	10.1994 → 12.1995	ADY	B	297
1.3	08.1980 → 07.1983	FY	B	31	2.0 Syncro	07.1995 → 08.1996	AGG	B	301
1.3	08.1980 → 07.1983	FZ	B	31	2.8 VR6	06.1991 → 08.1996	AAA	B	225
1.3	08.1980 → 07.1986	EP	B	30	<b>PASSAT B3/B4 Variant (3A5, 35l)</b>				
1.3	08.1980 → 07.1986	EU	B	33	1.6	04.1988 → 07.1989	RF	B	190
1.6	08.1980 → 11.1980	WY	B	126	1.6	04.1988 → 07.1991	1F	B	217
1.6	01.1981 → 02.1983	YP	B	127	1.6	04.1988 → 07.1991	EZ	B	194
1.6	08.1981 → 07.1983	WV	B	131	1.6	07.1994 → 12.1995	AEK	B	232
1.6	08.1984 → 03.1988	DT	B	191	1.6	12.1995 → 12.1995	AFT	B	234
1.6	02.1986 → 03.1988	RL	B	207	1.6 TD	08.1988 → 07.1989	RA	D	106
1.6	08.1986 → 03.1988	DTA	B	207	1.6 TD	08.1989 → 10.1993	SB	D	106
1.6	03.1987 → 03.1988	PP	B	213	1.8	02.1988 → 07.1991	RP	B	216
1.6 D	08.1980 → 07.1982	CR	D	102	1.8	04.1988 → 07.1990	PF	B	205
1.6 D	08.1982 → 03.1988	JK	D	105	1.8	04.1988 → 07.1992	PB	B	205
1.6 TD	04.1982 → 03.1988	CY	D	104	1.8	08.1990 → 05.1997	AAM	B	222
1.7	09.1981 → 12.1983	WT	B	131	1.8	08.1991 → 09.1993	KR	B	211
1.8	01.1983 → 03.1988	DS	B	196	1.8	08.1991 → 09.1994	ABS	B	226
1.8	01.1983 → 03.1988	JV	B	196	1.8	08.1994 → 05.1997	ADZ	B	227
1.8	08.1983 → 03.1988	JN	B	196	1.8 16V	04.1988 → 12.1989	KR	B	211
1.8	12.1983 → 03.1988	DZ	B	201	1.8 G60 Syncro	08.1988 → 05.1997	PG	B	219
1.8	05.1986 → 03.1988	RM	B	202	1.9 D	05.1989 → 10.1993	1Y	D	134
1.8 Syncro	01.1986 → 03.1988	DS	B	196	1.9 TD	03.1991 → 05.1997	AAZ	D	137
1.8 Syncro	01.1986 → 03.1988	JN	B	196	1.9 TDI	10.1993 → 07.1996	1Z	D	138

V

			Pos				Pos		
1.9 TDI	03.1996 → 05.1997	AFN	D	140	1.8 Syncro/4motion	06.1997 → 11.2000	ADR	B	237
1.9 TDI	08.1996 → 05.1997	AHU	D	140	1.8 Syncro/4motion	01.1999 → 11.2000	APT	B	237
2.0	11.1991 → 09.1994	2E	B	297	1.8 Syncro/4motion	02.1999 → 11.2000	ARG	B	237
2.0	10.1993 → 09.1994	2E	B	297	1.8 T	05.1997 → 11.2000	APU	B	239
2.0	10.1993 → 10.1996	ADY	B	297	1.8 T	06.1997 → 12.1998	AEB	B	239
2.0	10.1994 → 07.1995	ADY	B	297	1.8 T	01.1999 → 11.2000	ANB	B	239
2.0	03.1995 → 08.1996	AEP	B	300	1.9 TDI	06.1997 → 11.2000	AFN	D	140
2.0	07.1995 → 10.1996	AGG	B	301	1.9 TDI	06.1997 → 11.2000	AHH	D	152
2.0	07.1995 → 05.1997	AGG	B	301	1.9 TDI	06.1997 → 11.2000	AHU	D	140
2.0 16V	08.1988 → 09.1993	9A	B	296	1.9 TDI	08.1998 → 12.1999	AJM	D	156
2.0 16V	01.1994 → 05.1997	ABF	B	298	1.9 TDI	08.1999 → 11.2000	AVG	D	149
2.0 Syncro	03.1990 → 09.1994	2E	B	297	1.9 TDI	01.2000 → 11.2000	ATJ	D	156
2.0 Syncro	10.1994 → 07.1995	ADY	B	297	1.9 TDI	02.2000 → 11.2000	AVB	D	156
2.0 Syncro	07.1995 → 12.1996	AGG	B	301	1.9 TDI 4motion	08.1999 → 11.2000	AJM	D	156
2.8 VR6	06.1991 → 05.1997	AAA	B	225	1.9 TDI 4motion	08.1999 → 11.2000	ATJ	D	156
2.9 VR6 Syncro	01.1994 → 05.1997	ABV	B	294	1.9 TDI Syncro/4motion	06.1997 → 08.2000	AFN	D	140
<b>PASSAT B5 (3B2)</b>					1.9 TDI Syncro/4motion	08.1999 → 08.2000	AVG	D	149
1.6	10.1996 → 11.2000	ADP	B	235	2.3 VR5	06.1997 → 11.2000	AGZ	B	238
1.6	10.1996 → 11.2000	AHL	B	235	2.3 VR5 Syncro/4motion	10.1997 → 11.2000	AGZ	B	238
1.6	10.1996 → 11.2000	ANA	B	235	2.5 TDI	07.1998 → 11.2000	AFB	D	122
1.6	10.1996 → 11.2000	ARM	B	235	2.5 TDI	07.1998 → 11.2000	AKN	D	123
1.8	10.1996 → 11.2000	ADR	B	237	2.5 TDI Syncro/4motion	12.1998 → 11.2000	AFB	D	122
1.8	01.1997 → 11.2000	AFY	B	240	2.5 TDI Syncro/4motion	12.1998 → 11.2000	AKN	D	123
1.8	01.1999 → 11.2000	APT	B	237	2.8 Syncro	05.1997 → 09.1999	AGE	B	302
1.8	02.1999 → 11.2000	ARG	B	237	2.8 V6	06.1997 → 11.1998	ACK	B	302
1.8 Syncro/4motion	12.1996 → 08.2000	ADR	B	237	2.8 V6	06.1997 → 11.2000	AQD	B	302
1.8 Syncro/4motion	01.1999 → 08.2000	APT	B	237	2.8 V6	06.1997 → 11.2000	ATQ	B	302
1.8 Syncro/4motion	02.1999 → 08.2000	ARG	B	237	2.8 V6	09.1997 → 09.1999	AGE	B	302
1.8 T	10.1996 → 12.1998	AEB	B	239	2.8 V6	01.1999 → 11.2000	APR	B	302
1.8 T	01.1999 → 11.2000	ANB	B	239	2.8 V6	09.1999 → 11.2000	ATX	B	302
1.8 T	01.1999 → 11.2000	APU	B	239	2.8 V6 4motion	09.1999 → 11.2000	ATX	B	302
1.9 TDI	10.1996 → 11.2000	AFN	D	140	2.8 V6 Syncro/4motion	06.1997 → 12.1998	ACK	B	302
1.9 TDI	10.1996 → 11.2000	AHH	D	152	2.8 V6 Syncro/4motion	06.1997 → 12.1998	ALG	B	302
1.9 TDI	10.1996 → 11.2000	AHU	D	140	2.8 V6 Syncro/4motion	06.1997 → 11.2000	ATQ	B	302
1.9 TDI	08.1998 → 12.1999	AJM	D	156	2.8 V6 Syncro/4motion	01.1999 → 11.2000	APR	B	302
1.9 TDI	08.1999 → 11.2000	AVG	D	149	2.8 V6 Syncro/4motion	01.1999 → 11.2000	AQD	B	302
1.9 TDI	01.2000 → 11.2000	ATJ	D	156	<b>PASSAT B5.5 (3B3)</b>				
1.9 TDI	02.2000 → 11.2000	AVB	D	156	1.6	11.2000 → 05.2005	ALZ	B	255
1.9 TDI 4motion	01.2000 → 11.2000	ATJ	D	156	1.8	11.2000 → 03.2005	AFY	B	240
1.9 TDI Syncro/4motion	06.1997 → 08.2000	AFN	D	140	1.8 T	02.2001 → 11.2005	AWM	B	248
1.9 TDI Syncro/4motion	08.1999 → 08.2000	AVG	D	149	1.8 T 20V	11.2000 → 05.2005	AWT	B	248
2.3 VR5	10.1996 → 11.2000	AGZ	B	238	1.8 T 4motion	11.2003 → 05.2005	AWM	B	248
2.3 VR5 Syncro/4motion	10.1997 → 11.2000	AGZ	B	238	1.9 TDI	11.2000 → 05.2005	AVB	D	156
2.5 TDI	07.1998 → 11.2000	AFB	D	122	1.9 TDI	11.2000 → 05.2005	AVF	D	157
2.5 TDI	07.1998 → 11.2000	AKN	D	123	1.9 TDI	11.2000 → 05.2005	AWX	D	157
2.5 TDI Syncro/4motion	12.1998 → 11.2000	AFB	D	122	1.9 TDI 4motion	11.2000 → 05.2005	AVF	D	157
2.5 TDI Syncro/4motion	12.1998 → 11.2000	AKN	D	123	2.0	11.2000 → 05.2005	AZM	B	305
2.8 V6	08.1996 → 12.1998	ACK	B	302	2.0	11.2001 → 05.2005	ALT	B	302
2.8 V6	08.1996 → 11.2000	AQD	B	302	2.0 4motion	11.2000 → 05.2005	AZM	B	305
2.8 V6	05.1997 → 09.1999	AGE	B	302	2.0 TDI	12.2003 → 05.2005	BGW	D	269
2.8 V6	01.1999 → 11.2000	APR	B	302	2.0 TDI	12.2003 → 05.2005	BHW	D	269
2.8 V6	09.1999 → 11.2000	ATX	B	302	2.3 V5	11.2000 → 05.2005	AZX	B	249
2.8 V6	09.1999 → 11.2000	BBG	B	302	2.3 V5 4motion	11.2000 → 05.2005	AZX	B	249
2.8 V6 4motion	09.1999 → 11.2000	ATX	B	302	2.5 TDI	11.2000 → 05.2005	AKN	D	123
2.8 V6 Syncro/4motion	10.1996 → 12.1998	ACK	B	302	2.5 TDI	05.2003 → 05.2005	BDG	D	124
2.8 V6 Syncro/4motion	06.1997 → 11.2000	ALG	B	302	2.5 TDI 4motion	11.2000 → 05.2005	AFB	D	122
2.8 V6 Syncro/4motion	01.1999 → 11.2000	APR	B	302	2.5 TDI 4motion	11.2000 → 05.2005	AKN	D	123
2.8 V6 Syncro/4motion	01.1999 → 11.2000	AQD	B	302	2.5 TDI 4motion	01.2003 → 05.2005	BAU	D	124
<b>PASSAT B5 GP (3B3)</b>					2.5 TDI 4motion	01.2003 → 05.2005	BDH	D	124
2.5 TDI	10.2000 → 05.2003	AKN	D	123	2.8	10.2000 → 05.2005	BBG	B	302
<b>PASSAT B5 Variant (3B5)</b>					2.8	05.2002 → 05.2003	AMX	B	302
1.6	06.1997 → 11.2000	ADP	B	235	2.8	05.2002 → 05.2003	ATQ	B	302
1.6	06.1997 → 11.2000	AHL	B	235	2.8 4motion	10.2000 → 05.2005	BBG	B	302
1.6	07.1999 → 11.2000	ANA	B	235	2.8 4motion	11.2000 → 05.2005	AMX	B	302
1.6	07.1999 → 11.2000	ARM	B	235	2.8 4motion	11.2000 → 05.2005	ATQ	B	302
1.8	06.1997 → 11.2000	ADR	B	237	4.0 W8 4motion	09.2001 → 09.2004	BDN	B	363
1.8	06.1997 → 11.2000	AFY	B	240	4.0 W8 4motion	09.2001 → 09.2004	BDP	B	363
1.8	01.1999 → 11.2000	APT	B	237	<b>PASSAT B5.5 Variant (3B6)</b>				
1.8	02.1999 → 11.2000	ARG	B	237	1.6	11.2000 → 05.2005	ALZ	B	255

			Pos				Pos		
1.8 4motion	11.2003 → 05.2005	AWM	B	248	2.0 TDI 16V 4motion	03.2005 → 08.2010	BKP	D	267
1.8 T	05.2002 → 08.2005	AWM	B	248	2.0 TDI 16V 4motion	03.2005 → 08.2010	CBAB	D	272
1.8 T 20V	11.2000 → 05.2005	AWT	B	248	2.0 TDI 4motion	03.2005 → 05.2009	BMP	D	273
1.9 TDI	11.2000 → 05.2005	AVB	D	156	2.0 TDI 4motion	05.2009 → 07.2010	CBBB	D	272
1.9 TDI	11.2000 → 05.2005	AVF	D	157	3.2 FSI 4motion	11.2005 → 07.2010	AXZ	B	383
1.9 TDI	11.2000 → 05.2005	AWX	D	157	3.6 FSI	06.2005 → 07.2010	BLV	B	385
1.9 TDI 4motion	11.2000 → 05.2005	AVF	D	157	3.6 FSI 4motion	09.2005 → 07.2010	BLV	B	385
2.0	11.2000 → 05.2005	AZM	B	305	3.6 R36 4motion	04.2007 → 07.2010	BWS	B	385
2.0	11.2001 → 05.2005	ALT	B	302	<b>PASSAT B6 Variant (3C5)</b>				
2.0 4motion	11.2000 → 05.2005	AZM	B	305	1.4 TSI	05.2007 → 11.2010	CAXA	B	78
2.0 TDI	12.2003 → 05.2005	BGW	D	269	1.4 TSI EcoFuel	01.2009 → 11.2010	CDGA	BG	45
2.0 TDI	12.2003 → 05.2005	BHW	D	269	1.6	08.2005 → 11.2010	BSE	B	257
2.3 VR5	11.2000 → 05.2005	AZX	B	249	1.6	08.2005 → 11.2010	BSF	B	257
2.3 VR5 4motion	11.2000 → 05.2005	AZX	B	249	1.6 FSI	08.2005 → 06.2008	BLF	B	69
2.5 TDI	11.2000 → 05.2005	AKN	D	123	1.6 TDI	08.2009 → 11.2010	CAYC	D	181
2.5 TDI	05.2003 → 05.2005	BDG	D	124	1.8 TSI	05.2007 → 10.2011	BZB	B	315
2.5 TDI 4motion	11.2000 → 05.2005	AKN	D	123	1.8 TSI	05.2007 → 10.2011	CDA A	B	316
2.5 TDI 4motion	01.2003 → 05.2005	BAU	D	124	1.8 TSI	11.2009 → 11.2010	CDAB	B	319
2.5 TDI 4motion	01.2003 → 05.2005	BDH	D	124	1.8 TSI	11.2009 → 11.2010	CGYA	B	318
2.8	10.2000 → 05.2005	BBG	B	302	1.9 TDI	08.2005 → 11.2010	BKC	D	161
2.8	10.2000 → 08.2005	ATQ	B	302	1.9 TDI	08.2005 → 11.2010	BLS	D	171
2.8 4motion	10.2000 → 05.2005	BBG	B	302	1.9 TDI	08.2005 → 11.2010	BXE	D	161
2.8 4motion	11.2000 → 05.2005	AMX	B	302	2.0 BlueTDI	01.2009 → 11.2010	CBAC	D	278
2.8 4motion	11.2000 → 05.2005	ATQ	B	302	2.0 FSI	08.2005 → 11.2010	AXX	B	309
4.0 W8 4motion	09.2001 → 09.2004	BDN	B	363	2.0 FSI	08.2005 → 11.2010	BLR	B	308
4.0 W8 4motion	09.2001 → 09.2004	BDP	B	363	2.0 FSI	08.2005 → 11.2010	BLY	B	308
<b>PASSAT B6 (3C)</b>					2.0 FSI	08.2005 → 11.2010	BPY	B	309
2.8i VR6 30V	06.2005 → 11.2010	BBG	B	302	2.0 FSI	08.2005 → 11.2010	BVY	B	308
<b>PASSAT B6 (3C2)</b>					2.0 FSI	08.2005 → 11.2010	BVZ	B	308
1.4 TSI	05.2007 → 07.2010	CAXA	B	78	2.0 FSI	08.2005 → 11.2010	BWA	B	309
1.4 TSI EcoFuel	01.2009 → 07.2010	CDGA	BG	45	2.0 FSI	08.2005 → 11.2010	CAWB	B	310
1.6	05.2005 → 07.2010	BSE	B	257	2.0 FSI	08.2005 → 11.2010	CBFA	B	310
1.6	05.2005 → 07.2010	BSF	B	257	2.0 FSI	08.2005 → 11.2010	CCTA	B	310
1.6 FSI	03.2005 → 06.2008	BLF	B	69	2.0 FSI	08.2005 → 11.2010	CCZA	B	313
1.6 TDI	08.2009 → 07.2010	CAYC	D	181	2.0 FSI 4motion	09.2005 → 11.2010	BLX	B	308
1.8 TSI	05.2007 → 07.2010	BZB	B	315	2.0 FSI 4motion	09.2005 → 11.2010	BLY	B	308
1.8 TSI	05.2007 → 07.2010	CDA A	B	316	2.0 FSI 4motion	09.2005 → 11.2010	BVX	B	308
1.8 TSI	11.2009 → 07.2010	CDAB	B	319	2.0 TDI	08.2005 → 02.2006	BVE	D	275
1.8 TSI	11.2009 → 07.2010	CGYA	B	318	2.0 TDI	08.2005 → 05.2009	BMP	D	273
1.9 TDI	03.2005 → 07.2010	BKC	D	161	2.0 TDI	08.2005 → 05.2009	BUZ	D	276
1.9 TDI	03.2005 → 07.2010	BLS	D	171	2.0 TDI	08.2005 → 11.2010	BMA	D	267
1.9 TDI	03.2005 → 07.2010	BXE	D	161	2.0 TDI	08.2005 → 11.2010	BMR	D	277
2.0 BlueTDI	01.2009 → 11.2010	CBAC	D	278	2.0 TDI	08.2005 → 11.2010	CBAA	D	272
2.0 FSI	03.2005 → 07.2010	BLR	B	308	2.0 TDI	08.2005 → 11.2010	CBBB	D	272
2.0 FSI	03.2005 → 07.2010	BLY	B	308	2.0 TDI	11.2005 → 05.2007	BWV	D	279
2.0 FSI	03.2005 → 07.2010	BVY	B	308	2.0 TDI	11.2008 → 11.2010	CBDC	D	278
2.0 FSI	03.2005 → 07.2010	BVZ	B	308	2.0 TDI 16V	08.2005 → 11.2010	BKP	D	267
2.0 FSI	07.2005 → 07.2010	AXX	B	309	2.0 TDI 16V	08.2005 → 11.2010	CBAB	D	272
2.0 FSI	07.2005 → 07.2010	BPY	B	309	2.0 TDI 16V 4motion	08.2005 → 11.2010	BKP	D	267
2.0 FSI	07.2005 → 07.2010	BWA	B	309	2.0 TDI 16V 4motion	08.2005 → 11.2010	CBAB	D	272
2.0 FSI	07.2005 → 07.2010	CAWB	B	310	2.0 TDI 4motion	08.2005 → 05.2009	BMP	D	273
2.0 FSI	07.2005 → 07.2010	CBFA	B	310	2.0 TDI 4motion	05.2009 → 11.2010	CBBB	D	272
2.0 FSI	07.2005 → 07.2010	CCTA	B	310	3.2 FSI 4motion	11.2005 → 11.2010	AXZ	B	383
2.0 FSI	07.2005 → 07.2010	CCZA	B	313	3.6 FSI	09.2005 → 11.2010	BLV	B	385
2.0 FSI	08.2007 → 07.2010	CCTB	B	310	3.6 FSI 4motion	09.2005 → 11.2010	BLV	B	385
2.0 FSI 4motion	09.2005 → 07.2010	BLX	B	308	3.6 R36 4motion	04.2007 → 11.2010	BWS	B	385
2.0 FSI 4motion	09.2005 → 07.2010	BLY	B	308	<b>PASSAT B7 (362)</b>				
2.0 FSI 4motion	09.2005 → 07.2010	BVX	B	308	1.4 TSI	08.2010 → 12.2014	CAXA	B	78
2.0 TDI	03.2005 → 05.2009	BMP	D	273	1.4 TSI	11.2012 → 12.2014	CTHD	B	80
2.0 TDI	03.2005 → 11.2010	BMA	D	267	1.4 TSI EcoFuel	08.2010 → 12.2014	CDGA	BG	45
2.0 TDI	03.2005 → 11.2010	CBAA	D	272	1.4 TSI MultiFuel	11.2010 → 12.2014	CKMA	AB	96
2.0 TDI	08.2005 → 07.2006	BVE	D	275	1.6 TDI	08.2010 → 12.2014	CAYC	D	181
2.0 TDI	08.2005 → 05.2009	BUZ	D	276	1.8 TSI	08.2010 → 12.2014	CDA A	B	316
2.0 TDI	08.2005 → 07.2010	BMR	D	277	1.8 TSI	02.2011 → 12.2014	CDAB	B	319
2.0 TDI	08.2005 → 07.2010	CBBB	D	272	2.0 TDI	08.2010 → 12.2014	CFFA	D	272
2.0 TDI	11.2005 → 05.2007	BWV	D	279	2.0 TDI	08.2010 → 12.2014	CFFB	D	272
2.0 TDI	11.2008 → 07.2010	CBDC	D	278	2.0 TDI	08.2010 → 12.2014	CFGB	D	272
2.0 TDI 16V	03.2005 → 07.2010	BKP	D	267	2.0 TDI	08.2010 → 12.2014	CLLA	D	287
2.0 TDI 16V	03.2005 → 07.2010	CBAB	D	272	2.0 TDI	12.2012 → 12.2014	CFGC	D	272

V

		Pos			Pos					
2.0 TDI 4motion	08.2010 → 01.2013	CFGB	D	272	1.4 TSI	11.2014 →	CZEA	B	21	
2.0 TDI 4motion	08.2010 → 12.2014	CFFB	D	272	1.4 TSI 4motion	02.2015 →	CZEA	B	21	
2.0 TDI 4motion	01.2013 → 12.2014	CFGC	D	272	1.6 TDI	08.2014 →	DCXA	D	184	
2.0 TSI	11.2010 → 12.2014	CCZB	B	313	1.8 TSI	02.2015 →	CJSA	B	340	
3.6 FSI 4motion	01.2011 → 12.2014	BWS	B	385	1.8 TSI	02.2015 →	CJSC	B	341	
<b>PASSAT B7 (A32, A33)</b>						2.0 TDI	11.2014 →	CRLB	D	278
1.8 TSI	06.2013 →	CPKA	B	328	2.0 TDI	11.2014 →	DBGA	D	289	
1.8 TSI	06.2013 →	CPRA	B	328	2.0 TDI	11.2014 →	DDAA	D	291	
2.0 TDI	04.2011 → 06.2015	CFFB	D	272	2.0 TDI	11.2014 →	DFCA	D	289	
2.0 TDI	04.2011 → 06.2015	CKRA	D	278	2.0 TDI	11.2014 →	DFGA	D	289	
2.5	01.2011 →	CBTA	B	312	2.0 TDI	11.2014 →	DFHA	D	289	
2.5	01.2011 →	CBUA	B	312	2.0 TDI	11.2014 →	DSRA	D	292	
2.5	01.2011 →	CCCA	B	312	2.0 TDI	11.2014 →	DSRB	D	292	
<b>PASSAT B7 Variant (365)</b>						2.0 TDI 4motion	08.2014 → 11.2017	CRLB	D	278
1.4 TSI	08.2010 → 12.2014	CAXA	B	78	2.0 TDI 4motion	08.2014 → 11.2017	DFEA	D	289	
1.4 TSI	11.2012 → 12.2014	CTHD	B	80	2.0 TDI 4motion	08.2014 → 11.2017	DFGA	D	289	
1.4 TSI EcoFuel	08.2010 → 12.2014	CDGA	BG	45	2.0 TDI 4motion	11.2014 →	DDAA	D	291	
1.4 TSI MultiFuel	11.2010 → 12.2014	CKMA	AB	96	2.0 TDI 4motion	11.2014 →	DFCA	D	289	
1.6 TDI	08.2010 → 12.2014	CAYC	D	181	2.0 TDI 4motion	11.2014 →	DFHA	D	289	
1.8 TSI	08.2010 → 12.2014	CDAA	B	316	2.0 TSI	08.2014 →	CHHB	B	325	
1.8 TSI	02.2011 → 12.2014	CDAB	B	319	2.0 TSI	08.2014 →	CXDA	B	326	
2.0 TDI	08.2010 → 12.2014	CFFA	D	272	2.0 TSI	11.2018 →	CZPB	B	342	
2.0 TDI	08.2010 → 12.2014	CFFB	D	272	2.0 TSI	11.2018 →	DKZA	B	342	
2.0 TDI	08.2010 → 12.2014	CFGB	D	272	2.0 TSI 4motion	05.2015 →	CJXA	B	326	
2.0 TDI	08.2010 → 12.2014	CLLA	D	287	2.0 TSI 4motion	09.2018 →	DNUA	B	335	
2.0 TDI	12.2012 → 12.2014	CFGC	D	272	<b>PASSAT CC B6 (357)</b>					
2.0 TDI 4motion	08.2010 → 01.2013	CFGB	D	272	1.4 TSI MultiFuel	01.2011 → 01.2012	CKMA	AB	96	
2.0 TDI 4motion	08.2010 → 12.2014	CFFB	D	272	1.8 TSI	06.2008 → 01.2012	BZB	B	315	
2.0 TDI 4motion	01.2013 → 12.2014	CFGC	D	272	1.8 TSI	06.2008 → 01.2012	CDAA	B	316	
2.0 TSI	11.2010 → 12.2015	CCZB	B	313	1.8 TSI	11.2008 → 05.2010	CDAB	B	319	
3.6 FSI 4motion	01.2011 → 12.2014	BWS	B	385	1.8 TSI	11.2008 → 05.2010	CGYA	B	318	
<b>PASSAT B8 (3G2, CB2)</b>						2.0 BlueTDI	05.2009 → 11.2010	CBAC	D	278
1.4 GTE Hybrid	06.2015 → 11.2018	CUKC	B	19	2.0 TDI	05.2008 → 05.2011	CBBA	D	278	
1.4 TSI	11.2014 →	CZCA	B	19	2.0 TDI	06.2008 → 05.2011	CBAA	D	272	
1.4 TSI	11.2014 →	CZDA	B	19	2.0 TDI	06.2008 → 05.2011	CFFA	D	272	
1.4 TSI	11.2014 →	CZEA	B	21	2.0 TDI	06.2008 → 01.2012	CBAB	D	272	
1.4 TSI 4motion	02.2015 →	CZEA	B	21	2.0 TDI	06.2008 → 01.2012	CBBB	D	272	
1.6 TDI	08.2014 →	DCXA	D	184	2.0 TDI	06.2008 → 01.2012	CFFB	D	272	
1.8 TSI	02.2015 →	CJSA	B	340	2.0 TDI	06.2008 → 01.2012	CFGB	D	272	
1.8 TSI	02.2015 →	CJSC	B	341	2.0 TDI	06.2008 → 01.2012	CLLA	D	287	
2.0 TDI	11.2014 →	CRLB	D	278	2.0 TDI 4motion	08.2009 → 01.2012	CBAB	D	272	
2.0 TDI	11.2014 →	DBGA	D	289	2.0 TDI 4motion	08.2009 → 01.2012	CFFB	D	272	
2.0 TDI	11.2014 →	DDAA	D	291	2.0 TDI 4motion	11.2009 → 01.2012	CBBB	D	272	
2.0 TDI	11.2014 →	DFCA	D	289	2.0 TDI 4motion	11.2009 → 01.2012	CFGB	D	272	
2.0 TDI	11.2014 →	DFGA	D	289	2.0 TSI	06.2008 → 01.2012	CAWB	B	310	
2.0 TDI	11.2014 →	DFHA	D	289	2.0 TSI	06.2008 → 01.2012	CBFA	B	310	
2.0 TDI	11.2014 →	DSRA	D	292	2.0 TSI	06.2008 → 01.2012	CCTA	B	310	
2.0 TDI	11.2014 →	DSRB	D	292	2.0 TSI	06.2008 → 01.2012	CCZA	B	313	
2.0 TDI	01.2016 → 05.2017	CRLD	D	289	2.0 TSI	11.2010 → 01.2012	CCZB	B	313	
2.0 TDI	05.2016 → 05.2017	DBGB	D	289	3.6 FSI	06.2008 → 01.2012	BLV	B	385	
2.0 TDI	05.2016 →	CRGA	D	289	3.6 FSI	06.2008 → 01.2012	CNNA	B	386	
2.0 TDI	11.2017 → 05.2017	DFGB	D	289	3.6 FSI 4motion	02.2008 → 12.2011	BWS	B	385	
2.0 TDI 4motion	08.2014 → 11.2017	CRLB	D	278	3.6 FSI 4motion	06.2008 → 01.2012	BLV	B	385	
2.0 TDI 4motion	08.2014 → 11.2017	DFEA	D	289	3.6 FSI 4motion	06.2008 → 01.2012	CNNA	B	386	
2.0 TDI 4motion	08.2014 → 11.2017	DFGA	D	289	<b>PHAETON (3D1, 3D2, 3D3, 3D4, 3D6, 3D7, 3D8, 3D9)</b>					
2.0 TDI 4motion	11.2014 →	DDAA	D	291	3.0 V6	04.2012 → 03.2016	CPFA	B	369	
2.0 TDI 4motion	11.2014 →	DFCA	D	289	3.0 V6 TDI 4motion	09.2004 → 05.2007	BMK	D	348	
2.0 TDI 4motion	11.2014 →	DFHA	D	289	3.0 V6 TDI 4motion	06.2007 → 11.2008	CARA	D	352	
2.0 TSI	02.2015 →	CHHB	B	325	3.0 V6 TDI 4motion	11.2008 → 03.2016	CARB	D	355	
2.0 TSI	02.2015 →	CXDA	B	326	3.0 V6 TDI 4motion	11.2008 → 03.2016	CEXA	D	351	
2.0 TSI	11.2018 →	CZPB	B	342	3.0 V6 TDI 4motion	11.2013 → 03.2016	CEXB	D	361	
2.0 TSI	11.2018 →	DKZA	B	342	3.2 V6	04.2002 → 05.2005	AYT	B	365	
2.0 TSI	09.2020 →	CHHB	B	325	3.2 V6	04.2002 → 05.2005	BKL	B	364	
2.0 TSI 4motion	05.2015 →	CJXA	B	326	3.2 V6 4motion	02.2004 → 11.2008	BKL	B	364	
2.0 TSI 4motion	09.2018 →	DNUA	B	335	3.2 V6 4motion	02.2004 → 11.2008	BRK	B	364	
<b>PASSAT B8 Variant (3G5, CB5)</b>						3.6 V6 4motion	11.2008 → 03.2016	CHNA	B	387
1.4 GTE Hybrid	06.2015 →	CUKC	B	19	3.6 V6 4motion	11.2008 → 03.2016	CMVA	B	387	
1.4 TSI	11.2014 →	CZCA	B	19	5.0 V10 TDI 4motion	11.2002 → 10.2006	AJS	D	264	
1.4 TSI	11.2014 →	CZDA	B	19	6.0 W12 4motion	04.2002 → 12.2005	BAN	B	362	

V



				Pos					Pos
6.0 W12 4motion	05.2005 → 03.2016	BRN	B	<b>368</b>	2.0 Total Flex	10.2008 → 01.2012	CFEA	AB	<b>344</b>
6.0 W12 4motion	05.2005 → 03.2016	BTT	B	<b>368</b>	<b>POLO CLASSIC (6KV_)</b>				
<b>PICKUP (USA)</b>					2.0i	08.1999 → 09.2001	ADC	B	<b>299</b>
1.6 D (USA)	03.1981 → 07.1982	CR	D	<b>102</b>	<b>POLO CLASSIC (86C, 80)</b>				
1.6 D (USA)	08.1982 → 07.1984	JK	D	<b>105</b>	1.0	01.1985 → 10.1986	GL	B	<b>34</b>
1.7i (USA)	08.1981 → 07.1984	EN	B	<b>126</b>	1.0	08.1989 → 07.1990	AAK	B	<b>38</b>
<b>POINTER</b>					1.0	08.1990 → 09.1994	AAU	B	<b>39</b>
1.8	11.1993 → 12.1996	RP	B	<b>216</b>	1.0	02.1992 → 12.1992	ACM	B	<b>29</b>
<b>POLO (6N2)</b>					1.3	01.1985 → 07.1985	HK	B	<b>35</b>
1.0	10.1999 → 09.2001	ALD	B	<b>2</b>	1.3	01.1985 → 07.1987	MH	B	<b>37</b>
1.0	10.1999 → 09.2001	AUC	B	<b>2</b>	1.3 Cat	07.1987 → 12.1988	MH	B	<b>37</b>
1.4	10.1999 → 09.2001	AKK	B	<b>54</b>	1.3 Cat	07.1987 → 12.1988	NZ	B	<b>29</b>
1.4	10.1999 → 09.2001	AKP	B	<b>59</b>	1.3 D	08.1986 → 12.1988	MN	D	<b>43</b>
1.4	10.1999 → 09.2001	ANX	B	<b>49</b>	1.4 D	10.1990 → 09.1994	1W	D	<b>44</b>
1.4	10.1999 → 09.2001	AUD	B	<b>54</b>	<b>POLO Coupe (86C, 80)</b>				
1.4 16V	10.1999 → 09.2001	AFK	B	<b>58</b>	1.0	05.1982 → 10.1986	GL	B	<b>34</b>
1.4 16V	10.1999 → 09.2001	AHW	B	<b>56</b>	1.0	08.1985 → 01.1992	HZ	B	<b>37</b>
1.4 16V	10.1999 → 09.2001	APE	B	<b>56</b>	1.0 Cat	08.1989 → 07.1990	AAK	B	<b>38</b>
1.4 16V	10.1999 → 09.2001	AQQ	B	<b>58</b>	1.0 Cat	08.1990 → 09.1994	AAU	B	<b>39</b>
1.4 16V	10.1999 → 09.2001	AUB	B	<b>58</b>	1.0 Cat	02.1992 → 12.1992	ACM	B	<b>29</b>
1.4 16V	05.2000 → 09.2001	AUA	B	<b>56</b>	1.1	10.1981 → 07.1983	HB	B	<b>6</b>
1.4 TDI	10.1999 → 09.2001	AMF	D	<b>158</b>	1.3	10.1981 → 07.1983	HH	B	<b>31</b>
1.4 TDi	01.2000 → 10.2000	ATL	D	<b>159</b>	1.3	09.1982 → 09.1989	GK	B	<b>35</b>
1.6 16V GTI	10.1999 → 09.2001	ARC	B	<b>61</b>	1.3	08.1983 → 07.1985	HK	B	<b>35</b>
1.6 16V GTI	10.1999 → 09.2001	AVY	B	<b>61</b>	1.3	08.1983 → 06.1987	MH	B	<b>37</b>
1.7 SDI	10.1999 → 09.2001	AKU	D	<b>148</b>	1.3	03.1991 → 09.1994	3F	B	<b>29</b>
1.9 D	10.1999 → 09.2001	AEF	D	<b>144</b>	1.3 Cat	07.1987 → 12.1988	MH	B	<b>37</b>
1.9 SDI	10.1999 → 09.2001	AGD	D	<b>145</b>	1.3 Cat	07.1987 → 12.1990	NZ	B	<b>29</b>
1.9 SDI	10.1999 → 09.2001	ASX	D	<b>148</b>	1.3 Cat	01.1989 → 08.1994	2G	B	<b>29</b>
<b>POLO (86)</b>					1.3 Cat	10.1989 → 09.1994	3F	B	<b>29</b>
0.9	09.1975 → 09.1981	HA	B	<b>6</b>	1.3 Cat	01.1991 → 08.1994	AAV	B	<b>40</b>
1.1	03.1975 → 09.1981	HB	B	<b>6</b>	1.3 D	08.1986 → 08.1990	MN	D	<b>43</b>
1.1	03.1975 → 09.1981	HC	B	<b>6</b>	1.3 G40	01.1987 → 08.1990	PY	B	<b>38</b>
1.3	12.1976 → 09.1981	HH	B	<b>31</b>	1.3 G40	08.1990 → 09.1994	PY	B	<b>38</b>
<b>POLO (9N_)</b>					1.4 D	08.1990 → 09.1994	1W	D	<b>44</b>
1.2	01.2002 → 05.2007	AWY	B	<b>65</b>	<b>POLO II (86C, 80)</b>				
1.2	01.2002 → 05.2007	BMD	B	<b>66</b>	0.9	10.1981 → 12.1981	HA	B	<b>6</b>
1.2	05.2007 → 11.2009	BBM	B	<b>66</b>	1.0	10.1981 → 10.1986	GL	B	<b>34</b>
1.2 12V	10.2001 → 07.2007	AZQ	B	<b>64</b>	1.0	08.1985 → 01.1992	HZ	B	<b>37</b>
1.2 12V	10.2001 → 07.2007	BME	B	<b>64</b>	1.0 Cat	08.1989 → 07.1990	AAK	B	<b>38</b>
1.2 12V	05.2007 → 11.2009	BZG	B	<b>64</b>	1.0 Cat	08.1990 → 09.1994	AAU	B	<b>39</b>
1.4	08.2002 → 11.2009	BLM	B	<b>63</b>	1.0 Cat	02.1992 → 12.1992	ACM	B	<b>29</b>
1.4 16V	10.2001 → 05.2008	AUA	B	<b>56</b>	1.1	10.1981 → 09.1989	HB	B	<b>6</b>
1.4 16V	10.2001 → 05.2008	AUB	B	<b>58</b>	1.3	10.1981 → 07.1983	HH	B	<b>31</b>
1.4 16V	10.2001 → 05.2008	BBY	B	<b>56</b>	1.3	08.1982 → 07.1988	HJ	B	<b>31</b>
1.4 16V	10.2001 → 05.2008	BBZ	B	<b>58</b>	1.3	09.1982 → 09.1989	GK	B	<b>35</b>
1.4 16V	10.2001 → 05.2008	BKY	B	<b>57</b>	1.3	08.1983 → 07.1985	HK	B	<b>35</b>
1.4 16V	05.2006 → 11.2009	BUD	B	<b>75</b>	1.3	08.1983 → 07.1985	HW	B	<b>36</b>
1.4 BiFuel	05.2006 → 11.2009	BUD	B	<b>75</b>	1.3	08.1983 → 07.1988	MH	B	<b>37</b>
1.4 FSI	02.2002 → 07.2006	AXU	B	<b>61</b>	1.3	10.1990 → 08.1994	3F	B	<b>29</b>
1.4 TDI	10.2001 → 06.2005	AMF	D	<b>158</b>	1.3 Cat	07.1987 → 12.1988	MH	B	<b>37</b>
1.4 TDI	10.2001 → 06.2005	BAY	D	<b>166</b>	1.3 Cat	07.1987 → 08.1992	NZ	B	<b>29</b>
1.4 TDI	04.2005 → 11.2009	BMS	D	<b>176</b>	1.3 Cat	01.1989 → 09.1994	2G	B	<b>29</b>
1.4 TDI	04.2005 → 11.2009	BNM	D	<b>166</b>	1.3 Cat	10.1989 → 03.1991	3F	B	<b>29</b>
1.4 TDI	04.2005 → 11.2009	BNV	D	<b>166</b>	1.3 Cat	01.1991 → 08.1994	AAV	B	<b>40</b>
1.4 TDI	04.2005 → 11.2009	BWB	D	<b>176</b>	1.3 D	08.1986 → 07.1990	MN	D	<b>43</b>
1.6	08.2002 → 05.2005	BAH	B	<b>63</b>	1.4 D	10.1990 → 09.1994	1W	D	<b>44</b>
1.6 16V	05.2006 → 11.2009	BTS	B	<b>74</b>	<b>POLO III (6N1)</b>				
1.6 Flex	05.2008 → 10.2014	CCRA	AB	<b>95</b>	1.7 SDI	04.1997 → 10.1999	AHG	D	<b>148</b>
1.6 Flex	06.2008 → 04.2009	CCRA	AB	<b>95</b>	100 1.4 16V	04.1996 → 10.1999	AFH	B	<b>55</b>
1.8 GTI	09.2005 → 11.2009	BJX	B	<b>248</b>	120 1.6 16V GTI	09.1998 → 10.1999	AJV	B	<b>58</b>
1.8 GTi Cup Edition	05.2006 → 11.2009	BBU	B	<b>248</b>	45 1.0	10.1994 → 09.1996	AEV	B	<b>42</b>
1.9 SDI	10.2001 → 11.2009	ASY	D	<b>147</b>	50 1.0	09.1996 → 10.1999	AER	B	<b>1</b>
1.9 TDI	10.2001 → 11.2009	ATD	D	<b>156</b>	50 1.0	09.1996 → 10.1999	ALL	B	<b>1</b>
1.9 TDI	10.2001 → 11.2009	AXR	D	<b>161</b>	55 1.3	10.1994 → 04.1997	ADX	B	<b>51</b>
1.9 TDI	10.2001 → 11.2009	BMT	D	<b>165</b>	55 1.4	08.1995 → 10.1999	AEX	B	<b>49</b>
1.9 TDI	11.2003 → 11.2009	ASZ	D	<b>157</b>	60 1.4	07.1995 → 10.1999	AEX	B	<b>49</b>
1.9 TDI	05.2004 → 11.2009	BLT	D	<b>172</b>	60 1.4	07.1995 → 10.1999	AKV	B	<b>49</b>
2.0	10.2004 → 01.2012	BBX	B	<b>306</b>	60 1.4	07.1995 → 10.1999	APQ	B	<b>49</b>

			Pos				Pos		
60 1.7 SDI	08.1997 → 10.1999	AKU	D	148	1.4 TDi	01.2003 → 12.2007	AMF	D	158
64 1.9 D	10.1994 → 10.1999	AEF	D	144	1.6	09.2002 → 05.2005	BAH	B	63
64 1.9 SDI	07.1996 → 10.1999	AGD	D	145	1.6	01.2007 → 12.2010	BTS	B	74
75 1.6	10.1994 → 10.1999	AEA	B	52	1.9 TDi	07.2003 → 12.2010	ATD	D	156
75 1.6	07.1995 → 10.1999	AEE	B	53	<b>POLO PLAYA</b>				
75 1.6	03.1996 → 10.1999	AHS	B	52	1.0	05.1999 → 05.2002	ALD	B	2
75 1.6 4motion	08.1995 → 10.1999	AEA	B	52	1.6	10.1999 → 10.2004	AKL	B	235
<b>POLO III (6N /6KV )</b>					1.8	01.1995 → 10.1999	ADZ	B	227
1.8i	03.1998 → 09.2001	ADD	B	228	<b>POLO SEDAN (9A4)</b>				
2.0i	09.1994 → 04.1997	ADC	B	299	2.0i	04.2002 → 11.2009	BBX	B	306
<b>POLO III CLASSIC (6V2)</b>					<b>POLO V (6R)</b>				
1.6	05.1996 → 09.2001	AKL	B	235	1.6i	11.2009 →	BAH	B	63
1.6	11.2002 → 07.2006	BAH	B	63	<b>POLO V (6R1, 6C1)</b>				
1.6	11.2002 → 07.2006	CCRA	AB	95	1.0	01.2014 →	CHYA	B	20
1.9 SDI	06.1996 → 09.2001	AEY	D	145	1.0	01.2014 →	CHYB	B	20
1.9 TDi	01.1997 → 08.1999	AHU	D	140	1.0 TSi	11.2014 →	CHZB	B	19
100 1.6	12.1995 → 09.2001	AFT	B	234	1.0 TSi	11.2014 →	CHZC	B	19
100 1.6	12.1995 → 09.2001	APF	B	235	1.2	06.2009 →	CGPA	B	64
100 1.6	08.1997 → 09.2001	AKL	B	235	1.2	06.2009 →	CGPB	B	64
100 1.6	09.1997 → 09.2001	AEH	B	235	1.2	08.2011 →	CJLA	B	91
100 1.6	05.2000 → 09.2001	AUR	B	235	1.2 TDi	10.2009 →	CFWA	D	183
110 1.9 TDi	06.1998 → 01.2002	AFN	D	140	1.2 TSi	11.2009 →	CBZB	B	8
110 1.9 TDi	06.1998 → 01.2002	ASV	D	150	1.2 TSi	05.2011 → 05.2014	CBZC	B	10
2.0	08.1999 → 09.2001	ADC	B	299	1.2 TSi	01.2014 →	CJZD	B	15
2.0	01.2002 → 12.2003	ADC	B	299	1.2 TSi 16V	02.2014 → 10.2017	CJZC	B	16
54 1.4	01.1998 → 08.1999	ANX	B	49	1.4 (6R1)	03.2009 → 05.2014	CGGB	B	76
57 1.7 SDI	07.1997 → 09.2001	AKW	D	153	1.4 (6R1)	03.2009 → 05.2014	CLPA	B	83
60 1.4	12.1995 → 09.1997	AEX	B	49	1.4 BiFuel	03.2010 → 01.2011	CMAA	B	85
60 1.4	12.1995 → 09.2001	APQ	B	49	1.4 GTI	05.2010 →	CAVE	B	86
60 1.4	12.1995 → 09.2001	AUD	B	54	1.4 GTI	05.2010 →	CTHE	B	87
60 1.4	10.1997 → 10.1999	AKV	B	49	1.4 TDi	02.2014 →	CUSB	D	184
60 1.4	10.1999 → 09.2001	AKK	B	54	1.4 TDi	03.2014 → 10.2017	CUSA	D	184
60 1.4	10.1999 → 09.2001	ANW	B	54	1.4 TDi	05.2014 →	CUTA	D	184
64 1.9 D	01.1996 → 10.1996	1Y	D	134	1.4 TSi	10.2012 → 05.2014	CPTA	B	23
64 1.9 SDI	12.1995 → 08.1999	AEY	D	145	1.4 TSi	05.2014 → 10.2017	CZEA	B	21
68 1.9 SDI	08.1999 → 01.2002	AGP	D	155	1.6	01.2010 →	CFNA	B	84
68 1.9 SDI	08.1999 → 01.2002	AQM	D	147	1.6	01.2010 →	CLSA	B	84
75 1.4 16V	10.1999 → 09.2001	APE	B	56	1.6	07.2014 → 10.2017	CWVA	B	92
75 1.4 16V	05.2000 → 09.2001	AUA	B	56	1.6	07.2014 → 10.2017	CWVB	B	92
75 1.6	11.1995 → 09.1997	1F	B	217	1.6 BiFuel	01.2011 → 05.2014	CNKA	B	90
75 1.6	09.1997 → 12.1998	AEE	B	53	1.6 TDi	06.2009 →	CAYA	D	182
75 1.6	10.1999 → 09.2001	ALM	B	53	1.6 TDi	06.2009 →	CAYB	D	181
90 1.8	01.1997 → 09.2001	ABS	B	226	1.6 TDi	06.2009 →	CAYC	D	181
90 1.8	01.1997 → 09.2001	ADD	B	228	1.6 TDi	06.2009 →	CLNA	D	181
90 1.8	01.1997 → 09.2001	ADZ	B	227	1.8 GTI	11.2014 →	DAJA	B	337
90 1.9 TDi	09.1996 → 09.2001	AGR	D	151	1.8 GTI	11.2014 →	DAJB	B	338
90 1.9 TDi	01.1997 → 10.1997	AHU	D	140	1.8 GTI 230	04.2016 →	DAJA	B	337
90 1.9 TDi	08.1997 → 09.2001	ALH	D	150	2.0 R WRC	08.2013 → 05.2014	CDLJ	B	320
90 1.9 TDi	11.1997 → 09.2001	ALE	D	146	<b>POLO V Saloon (602, 604, 612, 614)</b>				
<b>POLO IV (9N )</b>					1.2 TSi	10.2013 →	CBZB	B	8
2.0i	04.2002 → 11.2009	BBX	B	306	1.4	12.2010 →	CLPA	B	83
<b>POLO IV Saloon (9A4, 9A2, 9N2, 9A6)</b>					1.4 TSi	05.2016 →	CZCA	B	19
1.4	11.2002 → 04.2012	BKY	B	57	1.6	05.2010 →	CFNA	B	84
1.4	07.2003 → 04.2012	BBY	B	56	1.6	05.2010 →	CLSA	B	84
1.4	11.2003 → 06.2005	BBZ	B	58	1.6	11.2010 →	CFNB	B	88
1.4	12.2003 → 08.2010	BLM	B	63	1.6	07.2014 →	CWVB	B	92
1.4 TDi	07.2003 → 06.2005	BAY	D	166	1.6	05.2015 →	CWVA	B	92
1.6	09.2002 →	BAH	B	63	1.6 TDi	07.2010 →	CLNA	D	181
1.6	09.2002 →	CCRA	AB	95	<b>POLO VI (AW1, BZ1)</b>				
1.6	09.2002 →	CFZA	B	67	1.0	06.2017 →	CHYB	B	20
1.6 Flex	05.2008 → 10.2014	CCRA	AB	95	1.0	08.2017 →	CHYC	B	21
1.6 Total Flex	10.2004 → 06.2006	CCRA	AB	95	1.0	08.2017 →	DFNB	B	21
1.9 SDI	11.2003 → 04.2012	ASY	D	147	1.0 MPi	09.2018 →	DFNA	B	21
1.9 TDi	09.2002 →	ATD	D	156	1.0 MPi	09.2018 →	DSGB	B	21
2.0	09.2002 →	BBX	B	306	1.0 TGI	09.2017 →	DBYA	BG	18
2.0	09.2002 →	CFEA	AB	344	1.0 TSi	06.2017 →	CHZL	B	19
2.0 Flex	10.2008 → 12.2014	CFEA	AB	344	1.0 TSi	06.2017 →	DKLA	B	26
<b>POLO IV Saloon (9N4)</b>					1.0 TSi	09.2017 →	CHZJ	B	26
1.4	01.2003 → 12.2010	BLM	B	63	1.0 TSi	09.2017 →	DKJA	B	26



					Pos						Pos
1.0 TSI	09.2017 →	DKRF	B	26	1.6	08.1981 → 12.1984	DT	B	191		
1.6 MPi	12.2017 →	CWVB	B	92	1.6 D	08.1981 → 07.1982	CR	D	102		
2.0 GTI	11.2017 →	CZPC	B	342	1.6 D	08.1982 → 12.1984	JK	D	105		
<b>POLO VIVO Hatchback (6S1, 6S3)</b>					1.6 TD	12.1981 → 12.1984	CY	D	104		
1.4	02.2010 → 09.2017	CLPA	B	83	1.7	09.1981 → 12.1983	WT	B	131		
1.6 16V	02.2010 → 09.2017	CLSA	B	84	1.8	01.1983 → 12.1984	DS	B	196		
<b>POLO VIVO Saloon (6S2, 6S4)</b>					1.8	09.1983 → 12.1985	JN	B	196		
1.4	02.2010 → 09.2017	CLPA	B	83	1.9	08.1981 → 07.1983	WN	B	130		
1.6	02.2010 → 09.2017	CLSA	B	84	2.0	08.1983 → 12.1984	HP	B	197		
<b>POLO Variant (6V5)</b>					2.0	08.1983 → 12.1984	JS	B	197		
1.4	05.1997 → 12.1997	AEX	B	49	2.2	09.1984 → 12.1985	KX	B	206		
1.4	05.1997 → 09.2001	AKK	B	54	<b>SAVEIRO (BR)</b>						
1.4	05.1997 → 09.2001	APQ	B	49	1.6 D	09.1997 → 11.1998	JK	D	105		
1.4	05.1997 → 09.2001	AUD	B	54	1.6 D	09.1997 → 11.1998	SB	D	106		
1.4	10.1997 → 09.2001	AKV	B	49	1.9 D	06.1998 → 03.2006	1Y	D	134		
1.4	12.1998 → 09.2001	AKP	B	59	1.9 D	06.2002 → 03.2006	BGG	D	168		
1.4	10.1999 → 09.2001	ANW	B	54	<b>SAVEIRO I (147)</b>						
1.4 16V	10.1999 → 09.2001	APE	B	56	1.6	09.1986 → 10.1989	HM	AB	258		
1.4 16V	05.2000 → 09.2001	AUA	B	56	1.6	08.1990 → 07.1996	1F	B	217		
1.6	05.1997 → 09.2001	AEE	B	53	1.6	08.1990 → 07.1996	EW	B	194		
1.6	05.1997 → 09.2001	AFT	B	234	1.6 D	10.1990 → 11.1997	ME	D	106		
1.6	05.1997 → 09.2001	APF	B	235	1.6 D	08.1991 → 07.1996	SB	D	106		
1.6	08.1997 → 09.2001	AKL	B	235	1.6 Álcool	07.1985 → 10.1989	HM	AB	258		
1.6	09.1997 → 09.2001	AEH	B	235	1.6 Álcool	04.1993 → 11.1996	YH	AB	132		
1.6	10.1999 → 09.2001	ALM	B	53	<b>SAVEIRO II (9U7)</b>						
1.6	05.2000 → 09.2001	AUR	B	235	1.6	07.1997 → 02.2002	1F	B	217		
1.7 SDI	08.1997 → 09.2001	AKW	D	153	1.6	07.1997 → 02.2002	EW	B	194		
1.8	05.1997 → 09.2001	ADZ	B	227	1.9 D	02.1998 → 02.2002	1Y	D	134		
1.9 SDI	06.1997 → 09.2001	AEY	D	145	<b>SAVEIRO III</b>						
1.9 SDI	08.1999 → 09.2001	AGP	D	155	1.9 D	07.2002 → 09.2005	BGG	D	168		
1.9 SDI	08.1999 → 09.2001	AQM	D	147	<b>SAVEIRO V (5U8, 5U9)</b>						
1.9 TDI	05.1997 → 10.1997	AHU	D	140	1.6	09.2009 →	CCRA	AB	95		
1.9 TDI	05.1997 → 09.2001	AGR	D	151	1.6	09.2009 →	CFZA	B	67		
1.9 TDI	08.1997 → 09.2001	ALH	D	150	1.6 Cross Flex	09.2009 →	CCRA	AB	95		
1.9 TDI	11.1997 → 09.2001	ALE	D	146	1.6 Total Flex	09.2009 →	CCRA	AB	95		
1.9 TDI	06.1998 → 09.2001	AFN	D	140	<b>SAVEIRO VI (5UA, 5UB, 5UC)</b>						
1.9 TDI	06.1998 → 09.2001	ASV	D	150	1.6 Total Flex	10.2014 → 10.2016	CCRA	AB	95		
<b>QUANTUM (USA)</b>					<b>SAVEIRO VII (5UD, 5UE, 5UF)</b>						
1.3	02.1977 → 1985	GF	B	32	1.6	01.2016 →	CFZA	B	67		
1.6 D	01.1981 → 07.1987	CS	D	103	1.6 Total Flex	01.2016 →	CCRA	AB	95		
1.6 TD	08.1981 → 07.1985	CY	D	104	<b>SCIROCCO (53)</b>						
1.7	08.1981 → 07.1983	WT	B	131	1.1	04.1974 → 07.1979	FA	B	6		
1.8	09.1983 → 07.1986	JN	B	196	1.3	08.1979 → 07.1980	GF	B	32		
2.0i	01.1981 → 1984	WN	B	130	1.5	02.1974 → 07.1974	ZB	B	46		
2.2i	08.1985 → 07.1988	JT	B	210	1.5	02.1974 → 12.1975	FH	B	46		
2.2i	08.1985 → 07.1988	KX	B	206	1.5	02.1974 → 12.1977	FD	B	46		
<b>QUANTUM Variant</b>					1.5	08.1974 → 08.1975	YJ	B	46		
1.8 Álcool	04.1994 → 12.1996	2H	B	220	1.5	08.1977 → 07.1980	JB	B	127		
<b>RABBIT (USA)</b>					1.5	09.1977 → 12.1978	EH	B	126		
1.5	05.1974 → 07.1980	FH	B	46	1.6	08.1975 → 07.1977	FT	B	126		
1.5	08.1977 → 07.1979	EH	B	126	1.6	08.1975 → 07.1979	FN	B	126		
1.5 D	09.1976 → 08.1980	CK	D	98	1.6	08.1975 → 07.1979	FP	B	127		
1.6	08.1975 → 07.1976	FN	B	126	1.6	08.1975 → 07.1980	FR	B	127		
1.6	03.1976 → 07.1977	EE	B	126	1.6	06.1976 → 07.1980	EG	B	128		
1.6 D	01.1981 → 07.1987	CS	D	103	1.6	09.1976 → 12.1977	EE	B	126		
1.6 D	03.1981 → 07.1982	CR	D	102	<b>SCIROCCO (53B)</b>						
1.6 D	08.1982 → 07.1984	JK	D	105	1.3	08.1980 → 12.1983	GF	B	32		
1.6 TD	08.1981 → 07.1984	CY	D	104	1.3	08.1983 → 07.1984	HK	B	35		
1.7	08.1981 → 07.1984	EN	B	126	1.5	08.1980 → 12.1983	JB	B	127		
1.8i	05.1983 → 07.1984	JH	B	195	1.6	08.1980 → 07.1982	EG	B	128		
<b>SANTANA</b>					1.6	08.1980 → 04.1984	FR	B	127		
1.8	01.1995 → 12.1999	JV	B	196	1.6	01.1983 → 12.1989	EW	B	194		
1.8 GL	05.1991 → 07.1994	JN	B	196	1.6	04.1986 → 07.1990	RE	B	212		
<b>SANTANA (1981/2000/3000)</b>					1.7	08.1980 → 07.1983	EN	B	126		
1.8i	08.1985 → 07.1986	KX	B	206	1.8	08.1982 → 07.1984	DX	B	193		
<b>SANTANA (32B)</b>					1.8	08.1983 → 07.1992	EX	B	200		
1.3	08.1981 → 07.1983	FZ	B	31	1.8	01.1984 → 04.1987	EV	B	193		
1.6	08.1981 → 12.1982	YP	B	127	1.8	11.1985 → 07.1992	JH	B	195		
1.6	08.1981 → 07.1983	VV	B	131	1.8	01.1987 → 12.1987	PB	B	205		

V

		Pos			Pos
1.8 16V	09.1985 → 12.1988	PL B 211	2.0 TDI	05.2010 →	CFFB D 272
1.8 16V	10.1985 → 07.1989	KR B 211	2.0 TDI	08.2010 →	CFGB D 272
1.8 16V	03.1986 → 07.1992	PL B 211	2.0 TDI	05.2011 → 07.2019	CFFE D 287
<b>SCIROCCO I (53)</b>			2.0 TDI	05.2011 → 07.2019	CUVA D 289
1.5i	02.1974 → 04.1974	FB B 46	2.0 TDI	01.2013 → 11.2015	CFGC D 272
<b>SCIROCCO II (53B)</b>			2.0 TDI	05.2015 → 11.2015	CUVC D 289
1.7i	08.1980 → 07.1983	EN B 126	2.0 TDI 4motion	05.2011 → 11.2015	CFFB D 272
<b>SCIROCCO III (137, 138)</b>			2.0 TDI 4motion	05.2015 →	CUVC D 289
1.4 TSI	05.2008 → 11.2017	CAVD B 73	2.0 TSI	12.2010 →	CCZA B 313
1.4 TSI	05.2008 → 11.2017	CNWA B 81	2.0 TSI	05.2015 →	DEDA B 337
1.4 TSI	05.2008 → 11.2017	CTHD B 80	<b>SP-1 / SP-2</b>		
1.4 TSI	05.2008 → 11.2017	CTKA B 81	1.6	06.1972 → 12.1974	AD B 378
1.4 TSI	08.2008 → 11.2017	CAXA B 78	<b>SPACEFOX (5Z)</b>		
1.4 TSI	08.2008 → 11.2017	CMSB B 82	1.9 SDI	09.2007 →	ASY D 147
1.4 TSI	11.2013 → 11.2017	CXSB B 24	<b>SPACEFOX / SPACE CROSS (5Z6, 5Z7, 5Z9)</b>		
1.4 TSI	11.2013 → 11.2017	CZCA B 19	1.6	03.2006 →	BAH B 63
1.4 TSI	07.2015 → 11.2017	CZDA B 19	1.6 Total Flex	03.2006 →	CCRA AB 95
1.4 TSI	07.2015 → 11.2017	CZDC B 19	1.9 SDI	11.2007 → 11.2010	ASY D 147
2.0 R	11.2009 → 11.2017	CDLA B 320	<b>SPACEFOX / SPACE CROSS Variant</b>		
2.0 R	11.2009 → 11.2017	CDLC B 314	1.6 MSI	10.2015 →	CFZA B 67
2.0 TDI	08.2008 → 11.2017	CBDB D 272	<b>SPORTVAN (5Z)</b>		
2.0 TDI	08.2008 → 11.2017	CFHC D 272	1.6i	01.2006 →	BAH B 63
2.0 TDI	05.2009 → 11.2017	CBBB D 272	1.9 SDI	09.2007 →	ASY D 147
2.0 TDI	05.2009 → 11.2017	CFGB D 272	<b>SURAN (5Z)</b>		
2.0 TDI	11.2010 → 11.2017	CFHB D 274	1.6i	01.2006 →	BAH B 63
2.0 TDI	01.2013 → 11.2017	CFGC D 272	1.9 SDI	09.2007 →	ASY D 147
2.0 TDI	11.2013 → 11.2017	CUUB D 289	<b>T-CROSS (C11)</b>		
2.0 TSI	05.2008 → 11.2009	CAWB B 310	1.0 TSi	12.2018 →	CHZL B 19
2.0 TSI	11.2009 → 11.2017	CCZB B 313	1.0 TSi	12.2018 →	DKJA B 26
2.0 TSI	11.2013 → 11.2017	CULA B 331	1.0 TSi	12.2018 →	DKLA B 26
2.0 TSI	11.2013 → 11.2017	CULC B 332	1.0 TSi	12.2018 →	DKRF B 26
<b>SENDA</b>			<b>T-ROC (A11)</b>		
1.6	03.1989 → 11.1997	HM AB 258	1.0 TSi	07.2017 →	CHZJ B 26
1.6 D	09.1983 → 09.1994	JP D 107	1.0 TSi	07.2017 →	DKRF B 26
<b>SHARAN (7M8, 7M9, 7M6)</b>			1.4 TSi	08.2020 →	DJKA B 26
1.8 T 20V	09.1997 → 03.2010	AJH B 239	1.6 TDI	03.2018 →	DGTE D 186
1.8 T 20V	04.2000 → 03.2010	AWC B 239	2.0 TDI 4motion	07.2019 →	DFHA D 289
1.9 TDI	09.1995 → 03.2010	IZ D 138	2.0 TSI 4motion	07.2017 →	CZPB B 342
1.9 TDI	09.1995 → 03.2010	AHU D 140	2.0 TSI 4motion	07.2017 →	DKZA B 342
1.9 TDI	09.1996 → 04.2000	AFN D 140	<b>T-ROC Convertible (AC7)</b>		
1.9 TDI	09.1996 → 04.2000	AVG D 149	1.0 TSi	12.2019 →	DKRF B 26
1.9 TDI	09.1999 → 03.2010	ANU D 157	<b>TARO</b>		
1.9 TDI	04.2000 → 03.2010	AUY D 157	2.4 D	06.1989 → 03.1997	2L D 391
1.9 TDI	04.2000 → 03.2010	BVK D 162	2.4 D	09.1991 → 07.1994	2L D 391
1.9 TDI	06.2001 →	BVK D 162	2.4 D	07.1994 → 03.1997	2L D 391
1.9 TDI	11.2002 → 03.2010	ASZ D 157	2.4 D 4x4	04.1989 → 03.1997	2L D 391
1.9 TDI	06.2005 → 03.2010	BTB D 177	2.4 D 4x4	07.1994 → 03.1997	2L D 391
1.9 TDI 4motion	04.2000 → 03.2010	AUY D 157	<b>TIGUAN (5N_)</b>		
2.0	09.1995 → 04.2000	ADY B 297	1.4 TSi	05.2008 → 07.2018	CAVA B 80
2.0	04.2000 → 03.2010	ATM B 305	1.4 TSi	05.2008 → 07.2018	CTHA B 81
2.0 LPG	04.2006 → 03.2010	ATM B 305	1.4 TSi	08.2010 → 07.2018	CAXA B 78
2.0 TDI	11.2005 → 03.2010	BRT D 280	1.4 TSi	05.2011 → 07.2018	CAVD B 73
2.0 TDI	11.2005 → 03.2010	BVH D 273	1.4 TSi	05.2011 → 07.2018	CTHD B 80
2.8 V6 24V	04.2000 → 03.2010	AYL B 249	1.4 TSi	05.2015 → 07.2018	CZDA B 19
2.8 V6 24V 4motion	04.2000 → 03.2010	AYL B 249	1.4 TSi	05.2015 → 07.2018	CZDB B 19
2.8 VR6	09.1995 → 04.2000	AAA B 225	1.4 TSi 4motion	09.2007 → 07.2018	BWK B 79
2.8 VR6	09.1995 → 04.2000	AMY B 233	1.4 TSi 4motion	09.2007 → 07.2018	CAVA B 80
2.8 VR6 Syncro	11.1996 → 04.2000	AAA B 225	1.4 TSi 4motion	09.2007 → 07.2018	CTHA B 81
2.8 VR6 Syncro	11.1996 → 04.2000	AMY B 233	1.4 TSi 4motion	05.2011 → 07.2018	CAVD B 73
<b>SHARAN (7M_)</b>			1.4 TSi 4motion	05.2011 → 07.2018	CTHD B 80
2.0 TDI BlueMotion	05.2008 → 03.2010	BRT D 280	2.0 FSI 16V	11.2007 → 05.2011	CCTA B 310
<b>SHARAN (7N1, 7N2)</b>			2.0 FSI 16V	06.2008 → 05.2009	CAWA B 310
1.4 TSi	05.2010 →	CAVA B 80	2.0 TDI	03.2008 → 07.2018	CBAB D 272
1.4 TSi	05.2010 →	CNWB B 83	2.0 TDI	03.2008 → 07.2018	CFFB D 272
1.4 TSi	05.2010 →	CTHA B 81	2.0 TDI	05.2010 → 07.2018	CFFD D 272
1.4 TSi	05.2015 →	CZDA B 19	2.0 TDI	05.2015 → 07.2018	CUVC D 289
1.4 TSi	05.2015 →	DJKA B 26	2.0 TDI 4motion	09.2007 → 07.2018	CBAB D 272
1.8 TSi	11.2011 →	CDAA B 316	2.0 TDI 4motion	09.2007 → 07.2018	CBBB D 272
2.0 TDI	05.2010 →	CFFA D 272	2.0 TDI 4motion	09.2007 → 07.2018	CFFB D 272

V

			Pos				Pos		
2.0 TDI 4motion	09.2007→07.2018	CFGB	D	272	6.0 W12	08.2004→05.2010	BJN	B	368
2.0 TDI 4motion	09.2007→07.2018	CLJA	D	272	6.0 W12	08.2004→05.2010	CFRA	B	368
2.0 TDI 4motion	11.2007→07.2018	CBA	A	272	TOUAREG (7P5, 7P6)				
2.0 TDI 4motion	11.2007→07.2018	CFFA	D	272	3.0 V6 TDI	01.2010→03.2018	CASA	D	351
2.0 TDI 4motion	02.2008→08.2009	CBBA	D	278	3.0 V6 TDI	01.2010→03.2018	CASD	D	356
2.0 TDI 4motion	11.2012→07.2018	CFGC	D	272	3.0 V6 TDI	01.2010→03.2018	CJMA	D	357
2.0 TDI 4motion	05.2015→07.2018	CUVC	D	289	3.0 V6 TDI	01.2010→03.2018	CNRB	D	357
2.0 TFSI	11.2007→07.2018	CAWB	B	310	3.0 V6 TDI	01.2010→03.2018	CRCD	D	359
2.0 TFSI	11.2007→07.2018	CCTA	B	310	3.0 V6 TDI	01.2010→03.2018	CVWA	D	359
2.0 TFSI 4motion	09.2007→07.2018	CAWA	B	310	3.0 V6 TDI	06.2010→03.2018	CATA	D	350
2.0 TFSI 4motion	09.2007→07.2018	CAWB	B	310	3.0 V6 TDI	05.2011→03.2018	CJGD	D	360
2.0 TFSI 4motion	09.2007→07.2018	CCTA	B	310	3.0 V6 TDI	05.2011→03.2018	CRCA	D	357
2.0 TFSI 4motion	09.2007→07.2018	CCTB	B	310	3.0 V6 TDI	09.2014→03.2018	CVVA	D	359
2.0 TFSI 4motion	09.2007→07.2018	CCZA	B	313	3.0 V6 TSI	08.2010→03.2018	CJTA	B	373
2.0 TFSI 4motion	09.2007→07.2018	CCZC	B	317	3.0 V6 TSI	01.2015→03.2018	CYJA	B	375
2.0 TSI 4motion	05.2011→07.2018	CCZB	B	313	3.0 V6 TSI Hybrid	04.2010→03.2018	CGEA	B	371
2.0 TSI 4motion	05.2011→07.2018	CCZD	B	321	3.0 V6 TSI Hybrid	04.2010→03.2018	CGFA	B	372
TIGUAN (AD1, AX1)					3.0 V6 TSI Hybrid	09.2010→03.2018	CGFA	B	372
1.4 TSI	01.2016→07.2018	CZCA	B	19	3.6 V6 FSI	04.2010→03.2018	CGRA	B	387
1.4 TSI	01.2016→07.2018	CZDA	B	19	3.6 V6 FSI	08.2010→03.2018	CMTA	B	387
1.4 TSI	01.2016→07.2018	CZEA	B	21	4.2 V8 FSI	01.2011→03.2018	CGNA	B	374
1.4 TSI 4motion	05.2016→07.2018	CZDA	B	19	4.2 V8 TDI	01.2010→03.2018	CKDA	D	358
1.4 TSI 4motion	05.2016→07.2018	CZEA	B	21	TOUAREG (CR7)				
1.6 TDI	05.2016→06.2020	DGDB	D	184	2.0 TSI 4motion	08.2018→11.2020	DMFA	B	326
2.0 TDI	01.2016→07.2020	DFGA	D	289	TOURAN (1T1, 1T2)				
2.0 TDI	05.2016→07.2019	DFGC	D	289	1.4 TSI	02.2006→05.2010	BMV	B	72
2.0 TDI	08.2016→07.2020	CYKC	D	289	1.4 TSI	02.2006→05.2010	CAVC	B	73
2.0 TDI 4motion	01.2016→07.2020	DBGC	D	289	1.4 TSI	11.2006→05.2010	BLG	B	72
2.0 TDI 4motion	01.2016→07.2020	DFGA	D	289	1.4 TSI	11.2006→05.2010	CAVB	B	77
2.0 TDI 4motion	04.2016→07.2020	DFHA	D	289	1.4 TSI EcoFuel	05.2009→05.2010	CDGA	BG	45
2.0 TDI 4motion	06.2016→07.2020	CRFD	D	289	1.6	07.2003→05.2010	BGU	B	256
2.0 TDI 4motion	08.2016→07.2020	CRGB	D	289	1.6	07.2003→05.2010	BSE	B	257
2.0 TSI 4motion	01.2016→	CZPA	B	342	1.6	07.2003→05.2010	BSF	B	257
2.0 TSI 4motion	06.2016→	CHHB	B	325	1.6 BiFuel	11.2006→05.2010	BSF	B	257
2.0 TSI 4motion	09.2018→07.2020	DKTA	B	342	1.6 FSI	02.2003→01.2007	BAG	B	68
2.0 TSI 4motion	09.2018→	DKZA	B	342	1.6 FSI	02.2003→01.2007	BLF	B	69
TIGUAN ALLSPACE (BW2)					1.6 FSI	02.2003→01.2007	BLP	B	69
1.4 TSI	06.2017→09.2018	CZDA	B	19	1.9 TDI	02.2003→05.2004	AVQ	D	169
1.4 TSI	06.2017→09.2018	CZEA	B	21	1.9 TDI	08.2003→05.2010	BKC	D	161
2.0 TDI	06.2017→	DFGA	D	289	1.9 TDI	08.2003→05.2010	BLS	D	171
2.0 TDI 4motion	06.2017→	DBGC	D	289	1.9 TDI	08.2003→05.2010	BXE	D	161
2.0 TDI 4motion	06.2017→	DFGA	D	289	1.9 TDI	11.2004→05.2010	BRU	D	173
2.0 TDI 4motion	06.2017→	DFHA	D	289	1.9 TDI	11.2004→05.2010	BXF	D	174
2.0 TSI 4motion	07.2017→	CXDA	B	326	1.9 TDI	11.2004→05.2010	BXJ	D	175
2.0 TSI 4motion	07.2017→	DNJA	B	326	2.0 EcoFuel	02.2006→05.2009	BSX	BG	295
2.0 TSI 4motion	09.2018→	DKTA	B	342	2.0 FSI	10.2003→01.2007	AXW	B	307
TOUAREG (7LA, 7L6, 7L7)					2.0 FSI	10.2003→01.2007	BLR	B	308
2.5 R5 TDI	01.2003→05.2010	BAC	D	265	2.0 FSI	10.2003→01.2007	BLX	B	308
2.5 R5 TDI	01.2003→05.2010	BPE	D	266	2.0 FSI	10.2003→01.2007	BLY	B	308
2.5 R5 TDI	08.2003→05.2010	BLK	D	265	2.0 FSI	10.2003→01.2007	BVY	B	308
2.5 R5 TDI	08.2003→05.2010	BPD	D	266	2.0 FSI	10.2003→01.2007	BVZ	B	308
3.0 TDI	04.2006→05.2010	BUN	D	349	2.0 TDI	02.2003→05.2010	AZV	D	267
3.0 TDI	04.2006→05.2010	CASB	D	351	2.0 TDI	12.2005→05.2010	BMM	D	271
3.0 V6 TDI	11.2004→05.2010	BKS	D	349	2.0 TDI	12.2005→05.2010	BMN	D	276
3.0 V6 TDI	11.2004→05.2010	CATA	D	350	2.0 TDI	12.2005→05.2010	CFJA	D	272
3.0 V6 TDI	11.2007→05.2010	CASA	D	351	2.0 TDI 16V	08.2003→05.2010	BKD	D	267
3.0 V6 TDI	11.2007→05.2010	CASC	D	353	TOURAN (1T3)				
3.2 V6	10.2002→11.2006	AZZ	B	365	1.2 TSI	05.2010→05.2015	CBZB	B	8
3.2 V6	10.2002→11.2006	BMV	B	366	1.4 TSI	05.2010→05.2015	CAVB	B	77
3.2 V6	10.2002→11.2006	BMX	B	364	1.4 TSI	05.2010→05.2015	CAVC	B	73
3.2 V6	10.2002→11.2006	BRJ	B	364	1.4 TSI	05.2010→05.2015	CTHB	B	83
3.2 V6	05.2003→11.2006	BKJ	B	365	1.4 TSI	05.2010→05.2015	CTHC	B	83
3.2 V6	11.2004→11.2006	BMV	B	366	1.4 TSI EcoFuel	05.2010→05.2015	CDGA	BG	45
3.6 V6 FSI	10.2005→05.2010	BHK	B	385	1.6 TDI	05.2010→05.2015	CAYB	D	181
4.2 V8 FSI	06.2006→05.2010	BAR	B	370	1.6 TDI	05.2010→05.2015	CAYC	D	181
5.0 R50 TDI	08.2007→05.2010	CBWA	D	262	2.0 TDI	05.2010→01.2013	CFJA	D	272
5.0 V10 TDI	10.2002→05.2010	AYH	D	261	2.0 TDI	05.2010→05.2015	CFHC	D	272
5.0 V10 TDI	10.2002→05.2010	BLE	D	262	2.0 TDI	11.2010→05.2015	CFHF	D	272
5.0 V10 TDI	10.2002→05.2010	BWF	D	263	2.0 TDI	11.2010→05.2015	CLCA	D	272

V

		Pos			Pos				
2.0 TDI	01.2013 → 05.2015	CFJB	D	278	1.8	09.1986 → 12.1995	RM	B	202
<b>TOURAN (5T1)</b>					<b>VOYAGE (5U4, 5U2, 5U6, 5UG)</b>				
1.2 TSI	05.2015 →	CYVB	B	12	1.0 Flex	07.2008 →	CCNA	B	4
1.4 TSI	05.2015 →	CZDA	B	19	1.6	07.2008 → 01.2014	CCRA	AB	95
1.6 TDI	05.2015 → 05.2016	CRKB	D	182	1.6	07.2008 → 01.2014	CFZA	B	67
1.6 TDI	05.2016 →	DGDA	D	186	1.6 Flex	02.2008 → 12.2015	CCRA	AB	95
1.8 TSI	11.2015 →	CJSA	B	340	1.6 Flex	10.2008 →	CCRA	AB	95
2.0 TDI	05.2015 →	DFEA	D	289	<b>VOYAGE (5X1)</b>				
2.0 TDI	05.2015 →	DFGA	D	289	1.0	08.1996 → 12.2001	AER	B	1
2.0 TDI	11.2015 → 07.2019	CRVA	D	278	1.9 D	06.1996 → 09.2001	1Y	D	134
2.0 TDI	11.2015 → 07.2019	CYKB	D	289	1.9 TDI	09.1999 → 09.2001	1Z	D	138
2.0 TDI	11.2015 → 07.2019	DFHA	D	289	<b>VW-PORSCHE 914</b>				
2.0 TDI	02.2016 → 05.2016	DFEB	D	289	1.7	01.1969 → 12.1973	W	B	389
2.0 TDI	05.2016 → 07.2018	DFGB	D	289					
2.0 TDI	02.2019 →	DFGC	D	289	<b>AMAROK Platform/Chassis (S1B, S6B, S7B)</b>				
<b>UP! (121, 122, BL1, BL2, BL3, 123)</b>					2.0 BiTDI	09.2011 → 07.2019	CNEA	D	272
1.0	08.2011 → 11.2019	CHYB	B	20	2.0 BiTDI	09.2011 → 07.2019	CSHA	D	272
1.0	08.2011 → 08.2020	CHYA	B	20	2.0 BiTDI 4motion	09.2011 → 07.2019	CNEA	D	272
1.0	08.2011 → 08.2020	DAFA	B	21	2.0 BiTDI 4motion	09.2011 → 07.2019	CSHA	D	272
1.0 EcoFuel	11.2012 → 08.2020	CPGA	BG	28	2.0 TDI	09.2011 → 08.2012	CDCA	D	272
1.0 TSI	05.2016 → 09.2018	CHZA	B	19	2.0 TDI	09.2011 → 10.2013	CDBA	D	272
<b>VENTO</b>					2.0 TDI	09.2011 → 10.2013	CNFA	D	272
1.2	01.2010 →	CBZB	B	8	2.0 TDI	09.2011 → 10.2016	CNFB	D	272
1.6	01.2010 → 12.2012	CFNA	B	84	2.0 TDI 4motion	09.2011 → 08.2012	CDCA	D	272
1.6	07.2010 →	CFNA	B	84	2.0 TDI 4motion	09.2011 → 10.2016	CNFB	D	272
1.6	07.2010 →	CLSA	B	84	2.0 TSI	09.2011 → 10.2016	CFPA	B	321
1.6 TDI	07.2010 → 08.2014	CLNA	D	181	<b>BUS</b>				
2.0 TDI 16V	02.2006 →	BKD	D	267	231	01.1960 → 1972	113 (34)	B	117
2.0 TDI 16V	01.2010 →	CLCA	D	272	241	01.1960 → 1972	113 (34)	B	117
2.0 TSI 16V	07.2006 →	BWA	B	309	<b>CADDY ALLTRACK Box Body/MPV (SAA)</b>				
2.0 TSI 16V	07.2006 →	CBFA	B	310	1.0 TSI	11.2015 →	CHZG	B	19
2.0 TSI 16V	07.2008 →	CAWB	B	310	1.2 TSI	06.2015 →	CYVC	B	14
2.5i 20V	06.2005 → 06.2007	BTK	B	312	1.4 TGI CNG	06.2015 →	CPWA	BG	17
2.5i 20V	07.2007 →	CCCA	B	312	1.4 TSI	05.2015 →	CZCB	B	19
<b>VENTO (1H2)</b>					1.6 TDI	05.2015 → 11.2017	CAYE	D	182
1.4	11.1991 → 07.1995	ABD	B	41	1.6 TDI	05.2015 →	CAYD	D	181
1.4	11.1991 → 09.1998	ABD	B	41	2.0 TDI	05.2015 → 11.2015	CUUB	D	289
1.4	11.1991 → 09.1998	AEX	B	49	2.0 TDI	05.2015 → 11.2015	CUUD	D	289
1.4	07.1995 → 09.1998	AEX	B	49	2.0 TDI	05.2015 → 11.2015	CUUF	D	289
1.6	09.1992 → 09.1994	ABU	B	50	2.0 TDI	05.2015 →	CFHC	D	272
1.6	10.1994 → 06.1995	AEA	B	52	2.0 TDI	05.2015 →	CLCB	D	272
1.6	10.1994 → 12.1995	AEK	B	232	2.0 TDI	11.2015 → 07.2019	DFSC	D	289
1.6	07.1995 → 09.1998	AEE	B	53	2.0 TDI	11.2015 →	DFSB	D	289
1.6	12.1995 → 09.1998	AFT	B	234	2.0 TDI	11.2015 →	DFSD	D	289
1.8	11.1991 → 09.1994	ABS	B	226	2.0 TDI	11.2015 →	DFSF	D	289
1.8	11.1991 → 09.1998	AAM	B	222	2.0 TDI 4motion	05.2015 → 05.2016	CFHF	D	272
1.8	11.1991 → 09.1998	ACC	B	229	2.0 TDI 4motion	05.2015 →	CFHC	D	272
1.8	11.1991 → 09.1998	ADD	B	228	2.0 TDI 4motion	05.2015 →	CUUE	D	289
1.8	10.1994 → 09.1998	ADZ	B	227	2.0 TDI 4motion	05.2015 →	DFSE	D	289
1.9 D	11.1991 → 09.1998	1Y	D	134	2.0 TDI 4motion	11.2015 →	DFSB	D	289
1.9 SDI	04.1997 → 09.1998	AEY	D	145	<b>CADDY Box Body/MPV (6K9, 9E7, 9E9)</b>				
1.9 TD	11.1991 → 09.1998	AAZ	D	137	1.8	09.2002 → 09.2005	ADD	B	228
1.9 TDI	09.1993 → 07.1996	1Z	D	138	1.9 D	10.2005 → 06.2009	1Y	D	134
1.9 TDI	04.1996 → 09.1998	AFN	D	140	<b>CADDY II Box Body/MPV (9K9A)</b>				
1.9 TDI	08.1996 → 09.1998	AHU	D	140	1.4	08.2000 → 01.2004	AUA	B	56
1.9 TDI	05.1997 → 09.1998	ALE	D	146	1.7 SDI	07.1996 → 09.2000	AHB	D	148
2.0	11.1991 → 09.1994	2E	B	297	1.9 D	11.1995 → 01.2004	1Y	D	134
2.0	10.1994 → 07.1995	ADY	B	297	1.9 SDI	11.1995 → 01.2004	AEY	D	145
2.0	07.1995 → 09.1998	AGG	B	301	1.9 SDI	11.1995 → 01.2004	AYQ	D	147
2.0	05.1997 → 09.1998	AKR	B	303	1.9 TDI	09.1996 → 01.2004	1Z	D	138
2.0 GL	11.1991 → 07.1998	AAC	B	221	1.9 TDI	09.1996 → 01.2004	AHU	D	140
2.0 GL	05.1996 → 12.1997	AEP	B	300	1.9 TDI	09.1996 → 01.2004	ALE	D	146
2.8 VR6	01.1992 → 09.1998	AAA	B	225	1.9 TDI	09.1996 → 01.2004	ALH	D	150
2.8 VR6	01.1992 → 09.1998	AAA	B	225	60 1.4	11.1995 → 01.2004	AEX	B	49
2.8 VR6	08.1995 → 04.1996	AAA	B	225	60 1.4	11.1995 → 01.2004	APQ	B	49
<b>VOYAGE</b>					60 1.4	11.1995 → 01.2004	AUD	B	54
1.3	06.1981 → 07.1982	AB	B	120	75 1.6	11.1995 → 05.1997	1F	B	217
1.5 Alcohol	06.1981 → 04.1982	ZC	B	46	75 1.6	06.1997 → 09.2000	AEE	B	53
1.8	05.1984 → 09.1988	RM	B	202					

V



					Pos						Pos	
<b>CADDY III Box Body/MPV (2KA, 2KH, 2CA, 2CH)</b>						2.0 TDI	05.2011 → 12.2016	CKTC	D	272		
1.2 TSI	09.2010 → 05.2015	CBZA	B	9	2.0 TDI	07.2011 → 12.2016	CKUB	D	272			
1.2 TSI	09.2010 → 05.2015	CBZB	B	8	2.0 TDI	07.2011 → 12.2016	CSNA	D	289			
1.4	03.2004 → 05.2006	BCA	B	57	2.0 TDI	10.2011 → 12.2016	CKUC	D	272			
1.4	05.2006 → 08.2010	BUD	B	75	2.0 TDI	11.2013 → 12.2016	CSLB	D	289			
1.6	04.2004 → 05.2015	BGU	B	256	2.0 TDI	11.2015 → 12.2016	CSLA	D	289			
1.6	04.2004 → 05.2015	BSE	B	257	2.0 TDI 4motion	11.2011 → 12.2016	CKUB	D	272			
1.6	04.2004 → 05.2015	BSF	B	257	2.0 TDI 4motion	11.2011 → 12.2016	CSNA	D	289			
1.6 BiFuel	05.2011 → 05.2015	CHGA	BG	189	2.5 TDI	04.2006 → 07.2011	BJJ	D	281			
1.6 TDI	08.2010 → 05.2015	CAYD	D	181	2.5 TDI	04.2006 → 07.2011	BJM	D	281			
1.6 TDI	08.2010 → 05.2015	CAYE	D	182	2.5 TDI	04.2006 → 07.2011	CEBA	D	282			
1.9 TDI	04.2004 → 08.2010	BJB	D	169	2.5 TDI	04.2006 → 07.2011	CECB	D	282			
1.9 TDI	04.2004 → 08.2010	BLS	D	171	2.5 TDI	04.2006 → 05.2013	BJK	D	281			
1.9 TDI	09.2005 → 08.2010	BSU	D	180	2.5 TDI	04.2006 → 05.2013	BJL	D	281			
1.9 TDI 4motion	11.2008 → 08.2010	BLS	D	171	2.5 TDI	04.2006 → 05.2013	CEBB	D	282			
2.0 EcoFuel	04.2006 → 05.2015	BSX	BG	295	2.5 TDI	04.2006 → 05.2013	CECA	D	283			
2.0 SDI	03.2004 → 08.2010	BDJ	D	270	<b>CRAFTER 30-50 Platform/Chassis (2F_)</b>							
2.0 SDI	03.2004 → 08.2010	BST	D	270	2.0 TDI	05.2011 → 12.2016	CKTB	D	272			
2.0 TDI	09.2007 → 08.2010	BMM	D	271	2.0 TDI	05.2011 → 12.2016	CKTC	D	272			
2.0 TDI	08.2010 → 05.2015	CLCA	D	272	2.0 TDI	05.2011 → 12.2016	CSLA	D	289			
2.0 TDI	11.2010 → 05.2015	CFHE	D	272	2.0 TDI	07.2011 → 12.2016	CKUB	D	272			
2.0 TDI	05.2012 → 05.2015	CFJA	D	272	2.0 TDI	07.2011 → 12.2016	CSNA	D	289			
2.0 TDI 16V	11.2010 → 05.2015	CFHC	D	272	2.0 TDI	10.2011 → 12.2016	CKUC	D	272			
2.0 TDI 16V	11.2010 → 05.2015	CLCB	D	272	2.0 TDI	11.2013 → 12.2016	CSLB	D	289			
2.0 TDI 16V 4motion	11.2010 → 05.2015	CFHC	D	272	2.0 TDI	11.2015 → 12.2016	CSLC	D	289			
2.0 TDI 4motion	08.2010 → 05.2015	CFHF	D	272	2.0 TDI 4motion	11.2011 → 12.2016	CKUB	D	272			
2.0 TDI 4motion	12.2010 → 05.2015	CFHE	D	272	2.0 TDI 4motion	11.2011 → 12.2016	CSNA	D	289			
<b>CADDY IV Box Body/MPV (SAA, SAH)</b>						2.5 TDI	04.2006 → 07.2011	BJJ	D	281		
1.0 TSI	11.2015 → 09.2020	CHZG	B	19	2.5 TDI	04.2006 → 07.2011	BJM	D	281			
1.2 TSI	06.2015 → 09.2020	CYVC	B	14	2.5 TDI	04.2006 → 07.2011	CEBA	D	282			
1.4 TGI CNG	06.2015 → 09.2020	CPWA	BG	17	2.5 TDI	04.2006 → 07.2011	CECB	D	282			
1.4 TSI	05.2015 → 09.2020	CZCB	B	19	2.5 TDI	04.2006 → 05.2013	BJK	D	281			
1.6	11.2015 → 09.2020	CWVA	B	92	2.5 TDI	04.2006 → 05.2013	BJL	D	281			
1.6 TDI	05.2015 → 11.2017	CAYE	D	182	2.5 TDI	04.2006 → 05.2013	CEBB	D	282			
1.6 TDI	05.2015 → 09.2020	CAYD	D	181	2.5 TDI	04.2006 → 05.2013	CECA	D	283			
2.0 TDI	05.2015 → 11.2015	CUUB	D	289	<b>CRAFTER 30-50 Van (2E_)</b>							
2.0 TDI	05.2015 → 11.2015	CUUD	D	289	2.0 TDI	05.2011 → 12.2016	CKTB	D	272			
2.0 TDI	05.2015 → 11.2015	CUUF	D	289	2.0 TDI	05.2011 → 12.2016	CKTC	D	272			
2.0 TDI	05.2015 → 09.2020	CFHC	D	272	2.0 TDI	05.2011 → 12.2016	CSLA	D	289			
2.0 TDI	05.2015 → 09.2020	CLCB	D	272	2.0 TDI	07.2011 → 12.2016	CKUB	D	272			
2.0 TDI	09.2015 → 09.2020	CLCA	D	272	2.0 TDI	07.2011 → 12.2016	CSNA	D	289			
2.0 TDI	11.2015 → 07.2019	DFSC	D	289	2.0 TDI	10.2011 → 12.2016	CKUC	D	272			
2.0 TDI	11.2015 → 09.2020	DFSB	D	289	2.0 TDI	11.2013 → 12.2016	CSLB	D	289			
2.0 TDI	11.2015 → 09.2020	DFSD	D	289	2.0 TDI	11.2015 → 12.2016	CSLC	D	289			
2.0 TDI	11.2015 → 09.2020	DFSF	D	289	2.0 TDI 4motion	07.2011 → 12.2016	CKUB	D	272			
2.0 TDI 4motion	05.2015 → 11.2015	CUUE	D	289	2.0 TDI 4motion	11.2013 → 12.2016	CSNA	D	289			
2.0 TDI 4motion	05.2015 → 09.2020	CFHC	D	272	2.5 TDI	04.2006 → 07.2011	BJJ	D	281			
2.0 TDI 4motion	05.2015 → 09.2020	CFHF	D	272	2.5 TDI	04.2006 → 07.2011	BJM	D	281			
2.0 TDI 4motion	05.2015 → 09.2020	CLCA	D	272	2.5 TDI	04.2006 → 07.2011	CEBA	D	282			
2.0 TDI 4motion	11.2015 → 07.2019	DFSC	D	289	2.5 TDI	04.2006 → 07.2011	CECB	D	282			
2.0 TDI 4motion	11.2015 → 09.2020	DFSB	D	289	2.5 TDI	04.2006 → 05.2013	BJK	D	281			
2.0 TDI 4motion	11.2015 → 09.2020	DFSE	D	289	2.5 TDI	04.2006 → 05.2013	BJL	D	281			
<b>CADDY MAXI (2K)</b>						2.5 TDI	04.2006 → 05.2013	CEBB	D	282		
1.2 TSI	09.2010 →	CBZB	B	8	2.5 TDI	04.2006 → 05.2013	CECA	D	283			
1.6 BiFuel	05.2011 →	CHGA	BG	189	<b>CRAFTER Bus (SYI, SYJ)</b>							
1.6 TDI	08.2010 →	CAYD	D	181	2.0 TDI	09.2016 →	DAUA	D	292			
1.6i	11.2007 → 08.2010	BSE	B	257	2.0 TDI	09.2016 →	DAVA	D	292			
1.6i	11.2007 → 08.2010	BSF	B	257	2.0 TDI	10.2016 →	DAUB	D	292			
1.9 TDI	11.2007 → 08.2010	BJB	D	169	2.0 TDI 4motion	03.2017 →	DAVA	D	292			
1.9 TDI	11.2007 → 08.2010	BLS	D	171	2.0 TDI 4motion	04.2017 →	DAUA	D	292			
2.0 EcoFuel	04.2006 →	BSX	BG	295	<b>CRAFTER Platform/Chassis (SZ_)</b>							
2.0 TDI	11.2007 → 08.2010	BMM	D	271	2.0 TDI	11.2016 →	DAUA	D	292			
2.0 TDI	08.2010 →	CLCA	D	272	2.0 TDI	11.2016 →	DAUB	D	292			
2.0 TDI	11.2010 →	CFHC	D	272	2.0 TDI	11.2016 →	DAVA	D	292			
2.0 TDI	11.2010 →	CFHE	D	272	2.0 TDI 4motion	03.2017 →	DAVA	D	292			
2.0 TDI	05.2012 →	CFJA	D	272	2.0 TDI 4motion	11.2017 →	DAUA	D	292			
2.0 TDI	12.2012 →	CLCB	D	272	<b>CRAFTER Van (SY_, SX_)</b>							
<b>CRAFTER 30-35 Bus (2E_)</b>						2.0 TDI	09.2016 →	DAUA	D	292		
2.0 TDI	05.2011 → 12.2016	CKTB	D	272	2.0 TDI	09.2016 →	DAVA	D	292			

V

		Pos			Pos
2.0 TDI 10.2016 →	DAUB D	292	1.6 TDi BlueMotion 05.2013 → 03.2017	CRKB D	182
2.0 TDI 4motion 03.2017 →	DAVA D	292	1.6 TDi BlueMotion 05.2013 → 03.2017	CXXA D	184
2.0 TDI 4motion 04.2017 →	DAUA D	292	1.6 TDi BlueMotion 05.2013 → 03.2017	CLHA D	182
<b>FOX Van (5Z1)</b>			4motion		
1.2 09.2010 → 12.2011	CHFA B	66	2.0 TDi BlueMotion 04.2013 → 03.2017	CRBC D	278
<b>GOLF Hatchback Van (1K1)</b>			2.0 TDi BlueMotion 04.2013 → 03.2017	CRLB D	278
TDI 11.2003 → 02.2006	BKC D	161	2.0 TDi BlueMotion 04.2013 → 03.2017	CRBC D	278
<b>GOLF II Van (19E, 1G1)</b>			4motion		
1.3 08.1983 → 07.1990	HK B	35	2.0 TDi BlueMotion 04.2013 → 03.2017	CRLB D	278
1.3 08.1983 → 07.1990	MH B	37	<b>GOLF VI Van (5K1_)</b>		
1.3 08.1983 → 07.1990	NZ B	29	1.2 TSi 05.2010 → 11.2012	CBZA B	9
1.6 D 08.1983 → 07.1991	JP D	107	1.2 TSi BlueMotion 05.2009 → 11.2012	CBZB B	8
1.8 i 08.1987 → 07.1991	RP B	216	1.4 TSi 10.2008 → 11.2012	CAVD B	73
<b>GOLF III Van (1H1)</b>			1.6 TDi 02.2009 → 11.2012	CAYB D	181
1.4 08.1991 → 05.1996	ABD B	41	1.6 TDi BlueMotion 05.2009 → 11.2012	CAYC D	181
1.4 08.1991 → 05.1996	AEX B	49	2.0 GTi 02.2009 → 11.2012	CCZB B	313
1.8 08.1991 → 07.1995	AAM B	222	2.0 TDi 09.2009 → 11.2012	CFFB D	272
1.8 08.1991 → 12.1997	ABS B	226	2.0 TDi 09.2009 → 11.2012	CJAA D	272
1.8 08.1991 → 12.1997	ADZ B	227	2.0 TDi 05.2010 → 11.2012	CFGB D	272
1.9 D 08.1991 → 07.1995	AAZ D	137	2.0 TSi R 4motion 11.2009 → 11.2012	CDLF B	314
1.9 SDI 08.1995 → 09.1997	AEY D	145	TSi 10.2008 → 11.2012	CAXA B	78
1.9 TDI 08.1991 → 09.1997	1Z D	138	<b>GOLF VII Van (5G1)</b>		
2.0 08.1995 → 09.1997	AGG B	301	1.2 TSi BlueMotion 08.2012 →	CJZB B	11
2.0 GTI 08.1991 → 09.1997	ABF B	298	1.2 TSi BlueMotion 11.2012 →	CJZA B	13
<b>GOLF IV Van (1J1)</b>			1.4 TSi BlueMotion 08.2012 →	CHPA B	22
1.9 SDI 11.1998 → 05.2004	AQM D	147	1.4 TSi BlueMotion 05.2013 →	CXSA B	22
1.9 TDI 10.1997 → 05.2004	AHF D	151	1.6 TDi BlueMotion 08.2012 →	CLHA D	182
1.9 TDI 05.2000 → 09.2002	AGR D	151	1.6 TDi BlueMotion 04.2013 →	CRKA D	182
1.9 TDI 04.2001 → 05.2004	ASZ D	157	1.6 TDi BlueMotion 11.2013 →	CRKB D	182
1.9 TDI 4motion 01.2000 → 04.2001	AUY D	157	1.6 TDi BlueMotion 11.2013 →	CXXB D	184
<b>GOLF PLUS Van (521)</b>			2.0 GTD 04.2013 →	CUNA D	278
1.2 TSi 11.2009 → 08.2014	CBZB B	8	2.0 GTi 04.2013 →	CHHB B	325
1.4 TSi 01.2009 → 09.2012	CAVD B	73	2.0 GTi 04.2015 →	CHHA B	325
1.4 TSi 01.2009 → 08.2014	CAXA B	78	2.0 TDi BlueMotion 05.2013 →	CKFC D	278
1.6 TDi 02.2009 → 08.2014	CAYB D	181	2.0 TDi BlueMotion 05.2013 →	CRBC D	278
1.6 TDi 02.2009 → 08.2014	CAYC D	181	4motion		
2.0 TDi 11.2009 → 08.2014	CFHC D	272	<b>GOLF Van III Variant (1H5)</b>		
<b>GOLF VAN IV Variant (1J5)</b>			1.4 05.1993 → 07.1995	ABD B	41
1.4 05.2000 → 06.2006	AXP B	57	1.4 05.1993 → 07.1995	AEX B	49
1.4 05.2000 → 06.2006	BCA B	57	1.8 07.1993 → 02.1999	AAM B	222
1.6 05.2000 → 06.2006	AUS B	57	1.8 08.1993 → 12.1999	ABS B	226
1.6 05.2000 → 06.2006	AZD B	62	1.8 08.1993 → 12.1999	ADZ B	227
1.6 05.2000 → 06.2006	BCB B	57	1.9 08.1993 → 02.1999	1Y D	134
1.9 SDI 05.1999 → 05.2006	AQM D	147	1.9 SDI 07.1995 → 02.1999	AEY D	145
1.9 TDI 05.1999 → 04.2002	AJM D	156	1.9 TDI 08.1993 → 12.1999	1Z D	138
1.9 TDI 05.1999 → 05.2006	AGR D	151	1.9 TDI 08.1993 → 12.1999	AHU D	140
1.9 TDI 05.1999 → 05.2006	AHF D	151	1.9 TDI 05.1996 → 02.1999	AFN D	140
1.9 TDI 05.1999 → 05.2006	ALH D	150	<b>GRAND CALIFORNIA Camper (SCB, SCC)</b>		
1.9 TDI 05.1999 → 05.2006	ASV D	150	2.0 TDI 04.2019 →	DAVA D	292
1.9 TDI 02.2000 → 06.2006	ATD D	156	2.0 TDI 4motion 04.2019 →	DAVA D	292
1.9 TDI 02.2000 → 06.2006	AXR D	161	<b>KOMBI Bus (T2)</b>		
1.9 TDI 04.2001 → 05.2006	ASZ D	157	1.6 05.1995 → 12.2005	CT AB	382
<b>GOLF VAN VI Variant (AJ5)</b>			<b>KOMBI Van (T2)</b>		
1.2 TSi 09.2009 → 05.2014	CBZB B	8	1.6 05.1995 → 12.2005	CT AB	382
1.4 TSi 07.2009 → 10.2012	CAVD B	73	1.6 Álcool 02.1998 → 12.2005	CT AB	382
1.4 TSi 07.2009 → 05.2014	CAXA B	78	<b>LOAD UP (121, 122, BL1, BL2)</b>		
1.6 TDi 12.2009 → 10.2012	CAYB D	181	1.0 12.2014 → 11.2019	CHYA B	20
1.6 TDi BlueMotion 07.2009 → 05.2014	CAYC D	181	1.0 12.2014 → 11.2019	DAFA B	21
2.0 TDi 07.2009 → 05.2014	CBDB D	272	1.0 BlueMotion 05.2016 → 11.2019	CHYB B	20
2.0 TDi 07.2009 → 05.2014	CFHC D	272	1.0 EcoFuel 12.2014 → 08.2020	CPGA BG	28
<b>GOLF VAN VII Variant (BA5)</b>			1.0 TSi BlueMotion 05.2016 → 09.2018	CHZA B	19
1.2 TSi BlueMotion 04.2013 → 03.2017	CJZA B	13	<b>LT 28-35 I Bus (281-363)</b>		
1.2 TSi BlueMotion 05.2013 → 03.2017	CJZB B	11	2.0 04.1975 → 09.1983	CH B	384
1.2 TSi BlueMotion 05.2013 → 03.2017	CYVA B	12	2.4 12.1982 → 07.1992	DL B	47
1.4 TSi BlueMotion 05.2013 → 03.2017	CHPA B	22	2.4 08.1988 → 12.1995	1E B	48
1.4 TSi BlueMotion 05.2013 → 03.2017	CXSA B	22	2.4 D 01.1979 → 09.1983	CP D	98
1.6 TDi BlueMotion 05.2013 → 03.2017	CLHA D	182	2.4 D 12.1982 → 07.1992	DW D	101
1.6 TDi BlueMotion 05.2013 → 03.2017	CLHB D	182	2.4 D 08.1989 → 07.1992	1S D	112
1.6 TDi BlueMotion 05.2013 → 03.2017	CRKA D	182	2.4 D 08.1992 → 06.1996	ACT D	112

V



				Pos					Pos
2.4 TD	12.1982 → 07.1989	DV	D	100	2.5 TDI	05.2001 → 07.2006	BBE	D	259
2.4 TD	08.1989 → 08.1992	1G	D	111	2.5 TDI	05.2001 → 07.2006	BBF	D	259
2.4 TD	09.1992 → 06.1996	ACL	D	115	2.8 TDI	07.1997 → 01.2002	AGK	D	393
2.4 i	08.1989 → 06.1996	1E	B	48	2.8 TDI	01.1999 → 07.2006	ATA	D	393
<b>LT 28-35 I Platform/Chassis (281-363)</b>					2.8 TDI	04.2002 → 07.2006	AUH	D	393
2.0	04.1975 → 09.1983	CH	B	384	2.8 TDI	04.2002 → 07.2006	BCQ	D	393
2.4	12.1982 → 07.1992	DL	B	47	<b>LT 40-55 I Platform/Chassis (293-909)</b>				
2.4	08.1988 → 04.1996	1E	B	48	2.0	04.1975 → 09.1983	CH	B	384
2.4 D	01.1979 → 09.1983	CP	D	98	2.4	08.1985 → 07.1989	DL	B	47
2.4 D	12.1982 → 02.1991	DW	D	101	2.4	08.1988 → 07.1989	1E	B	48
2.4 D	12.1982 → 07.1992	DW	D	101	2.4 D	01.1979 → 09.1983	CP	D	98
2.4 D	08.1990 → 07.1992	1S	D	112	2.4 D	12.1982 → 02.1991	DW	D	101
2.4 D	08.1992 → 06.1996	ACT	D	112	2.4 D	12.1982 → 07.1992	DW	D	101
2.4 D Syncro	08.1991 → 07.1992	1S	D	112	2.4 D	08.1990 → 07.1992	1S	D	112
2.4 D Syncro	08.1991 → 07.1992	DW	D	101	2.4 D	08.1992 → 06.1996	ACT	D	112
2.4 Syncro	08.1991 → 07.1992	DL	B	47	2.4 Syncro	12.1982 → 07.1989	DL	B	47
2.4 Syncro	08.1992 → 07.1994	1E	B	48	2.4 TD	12.1982 → 08.1992	DV	D	100
2.4 TD	12.1982 → 08.1992	DV	D	100	2.4 TD	08.1988 → 07.1991	1G	D	111
2.4 TD	08.1990 → 08.1992	1G	D	111	2.4 TD	08.1992 → 06.1996	ACL	D	115
2.4 TD	08.1992 → 06.1996	ACL	D	115	2.4 TD Syncro	08.1991 → 07.1992	1G	D	111
2.4 TD Syncro	08.1991 → 07.1992	1G	D	111	2.4 TD Syncro	08.1991 → 07.1992	DV	D	100
2.4 TD Syncro	08.1991 → 07.1992	DV	D	100	2.4 TD Syncro	08.1992 → 04.1996	ACL	D	115
2.4 TD Syncro	08.1992 → 04.1996	ACL	D	115	2.4 i	03.1994 → 06.1996	1E	B	48
2.4 i	03.1994 → 06.1996	1E	B	48	<b>LT 40-55 I Van (291-512)</b>				
<b>LT 28-35 I Van (281-363)</b>					2.0	04.1975 → 09.1983	CH	B	384
2.0	04.1975 → 09.1983	CH	B	384	2.4	12.1982 → 07.1992	DL	B	47
2.4	12.1982 → 07.1992	DL	B	47	2.4 4WD	12.1982 → 07.1992	DL	B	47
2.4 D	01.1979 → 09.1983	CP	D	98	2.4 D	01.1979 → 09.1983	CP	D	98
2.4 D	12.1982 → 07.1992	DW	D	101	2.4 D	12.1982 → 07.1992	DW	D	101
2.4 D	12.1982 → 07.1992	DW	D	101	2.4 D	12.1982 → 07.1992	DW	D	101
2.4 D	07.1990 → 07.1992	1S	D	112	2.4 D	07.1990 → 07.1992	1S	D	112
2.4 D	08.1992 → 05.1996	ACT	D	112	2.4 D	08.1992 → 05.1996	ACT	D	112
2.4 TD	02.1986 → 08.1992	DV	D	100	2.4 D 4WD	01.1979 → 03.1986	DW	D	101
2.4 TD	08.1988 → 08.1992	1G	D	111	2.4 TD	02.1986 → 08.1992	DV	D	100
2.4 TD	06.1992 → 05.1996	ACL	D	115	2.4 TD	08.1988 → 08.1992	1G	D	111
2.4 TD Syncro	08.1992 → 04.1996	ACL	D	115	2.4 TD	06.1992 → 05.1996	ACL	D	115
2.4 i	03.1994 → 06.1996	1E	B	48	2.4 TD 4WD	08.1978 → 07.1992	DV	D	100
<b>LT 28-35 II Bus (2DB, 2DE, 2DK)</b>					2.4 TD Syncro	08.1992 → 04.1996	ACL	D	115
2.3	05.1996 → 07.2006	AGL	B	390	2.4 i	01.1993 → 06.1996	1E	B	48
2.5 SDI	07.1996 → 07.2006	AGX	D	259	<b>MULTIVAN V (7HM, 7HN, 7HF, 7EM, 7EN)</b>				
2.5 TDI	05.1996 → 08.1999	AHD	D	259	1.9 TDI	04.2003 → 11.2009	AXB	D	157
2.5 TDI	05.1999 → 07.2006	ANJ	D	259	1.9 TDI	04.2003 → 11.2009	AXC	D	170
2.5 TDI	05.1999 → 07.2006	APA	D	259	1.9 TDI	01.2006 → 11.2009	BRR	D	180
2.5 TDI	05.1999 → 07.2006	AVR	D	259	1.9 TDI	06.2006 → 11.2009	BRS	D	180
2.5 TDI	05.2001 → 07.2006	BBE	D	259	2.0	11.2003 → 08.2015	AXA	BG	295
2.5 TDI	05.2001 → 07.2006	BBF	D	259	2.0 BiTDI	09.2009 → 08.2015	CFCA	D	288
2.8 TDI	07.1997 → 05.2003	AGK	D	393	2.0 BiTDI 4motion	09.2009 → 08.2015	CFCA	D	288
2.8 TDI	01.1999 → 01.2002	ATA	D	393	2.0 TDI	09.2009 → 08.2015	CAAA	D	272
2.8 TDI	05.2001 → 06.2006	AUH	D	393	2.0 TDI	09.2009 → 08.2015	CAAB	D	272
2.8 TDI	05.2001 → 06.2006	BCQ	D	393	2.0 TDI	09.2009 → 08.2015	CAAC	D	272
<b>LT 28-46 II Platform/Chassis (2DC, 2DF, 2DG, 2DL, 2DM)</b>					2.0 TDI	09.2009 → 08.2015	CCHA	D	272
2.3	06.1996 → 07.2006	AGL	B	390	2.0 TDI	05.2010 → 08.2015	CAAE	D	272
2.5 SDI	09.1996 → 07.2006	AGX	D	259	2.0 TDI	05.2010 → 08.2015	CCHB	D	272
2.5 TDI	06.1996 → 08.1999	AHD	D	259	2.0 TDI	05.2011 → 08.2015	CAAD	D	272
2.5 TDI	05.1999 → 07.2006	ANJ	D	259	2.0 TDI 4motion	09.2009 → 08.2015	CAAC	D	272
2.5 TDI	05.1999 → 07.2006	APA	D	259	2.0 TDI 4motion	09.2009 → 08.2015	CCHA	D	272
2.5 TDI	05.1999 → 07.2006	AVR	D	259	2.0 TDI 4motion	05.2010 → 08.2015	CAAE	D	272
2.5 TDI	05.2001 → 07.2006	BBE	D	259	2.0 TDI 4motion	05.2010 → 08.2015	CCHB	D	272
2.5 TDI	05.2001 → 07.2006	BBF	D	259	2.0 TSI	05.2011 → 08.2015	CJKA	B	321
2.8 TDI	07.1997 → 01.2002	AGK	D	393	2.0 TSI	07.2012 → 08.2015	CJKB	B	322
2.8 TDI	01.1999 → 07.2006	ATA	D	393	2.0 TSI 4motion	07.2011 → 08.2015	CJKA	B	321
2.8 TDI	04.2002 → 07.2006	AUH	D	393	2.5 TDI	04.2003 → 11.2009	AXD	D	265
<b>LT 28-46 II Van (2DA, 2DD, 2DH)</b>					2.5 TDI	04.2003 → 11.2009	AXE	D	268
2.3	05.1996 → 07.2006	AGL	B	390	2.5 TDI	04.2003 → 11.2009	BNZ	D	266
2.5 SDI	09.1996 → 07.2006	AGX	D	259	2.5 TDI	04.2003 → 11.2009	BPC	D	266
2.5 TDI	05.1996 → 08.1999	AHD	D	259	2.5 TDI	11.2003 → 11.2009	BLJ	D	265
2.5 TDI	05.1999 → 07.2006	ANJ	D	259	2.5 TDI 4motion	07.2004 → 11.2009	AXD	D	265
2.5 TDI	05.1999 → 07.2006	APA	D	259	2.5 TDI 4motion	07.2004 → 11.2009	AXE	D	268
2.5 TDI	05.1999 → 07.2006	AVR	D	259	2.5 TDI 4motion	07.2004 → 11.2009	BNZ	D	266

V

		Pos			Pos
2.5 TDI 4motion 07.2004 → 11.2009	BPC D	266	1.9 SDI 05.1996 → 08.1996	AEY D	145
3.2 V6 02.2004 → 06.2004	BDL B	364	1.9 SDI 10.1999 → 09.2001	AGP D	155
3.2 V6 02.2004 → 12.2009	BKK B	364	1.9 SDI 10.1999 → 09.2001	AQM D	147
3.2 V6 05.2008 → 12.2009	CFLA B	367	<b>POLO Van Hatchback Van (6N1)</b>		
3.2 V6 4motion 07.2004 → 12.2009	BKK B	364	1.0 10.1994 → 12.1999	AEV B	42
3.2 V6 4motion 05.2008 → 12.2009	CFLA B	367	<b>SCIROCCO Van (137)</b>		
<b>MULTIVAN VI (SGF, SGM, SGN, SHM, SHN)</b>			1.4 TSi 06.2008 → 05.2014	CAVD B	73
2.0 TDI 04.2015 →	CAAB D	272	1.4 TSi 08.2008 → 05.2014	CAXA B	78
2.0 TDI 04.2015 →	CAAC D	272	2.0 TDi 08.2008 → 05.2014	CBDB D	272
2.0 TDI 04.2015 →	CFCA D	288	2.0 TDi 08.2008 → 05.2014	CFHC D	272
2.0 TDI 04.2015 →	CXFA D	292	2.0 TDi 05.2009 → 05.2014	CBBB D	272
2.0 TDI 04.2015 →	CXGA D	292	2.0 TDi 05.2009 → 05.2014	CFGB D	272
2.0 TDI 04.2015 →	CXGB D	292	2.0 TFSi 11.2009 → 05.2014	CCZB B	313
2.0 TDI 04.2015 →	CXHA D	292	<b>SHARAN VAN (7M )</b>		
2.0 TDI 06.2015 →	CXEB D	292	1.9 TDI (7M6, 7M9) 04.2000 → 03.2010	AUY D	157
2.0 TDI 05.2016 →	CXHB D	292	1.9 TDI (7M8) 09.1996 → 05.2003	AFN D	140
2.0 TDI 11.2018 →	CXEC D	292	1.9 TDI (7M8, 7M9) 09.1996 → 05.2000	AHU D	140
2.0 TDI 07.2019 →	CXHC D	292	1.9 TDI (7M8, 7M9) 06.2000 → 05.2003	ANU D	157
2.0 TDI 4motion 06.2015 →	CAAC D	272	1.9 TDI (7M9) 11.2002 → 05.2003	ASZ D	157
2.0 TDI 4motion 06.2015 →	CFCA D	288	2.0 (7M8, 7M9) 09.1996 → 05.2000	ADY B	297
2.0 TDI 4motion 06.2015 →	CXEB D	292	2.0 (7M8, 7M9) 06.2000 → 07.2002	ATM B	305
2.0 TDI 4motion 08.2015 →	CXFA D	292	2.8 VR6 (7M8) 09.1996 → 04.2000	AAA B	225
2.0 TDI 4motion 08.2015 →	CXHA D	292	2.8 VR6 (7M9) 08.2001 → 05.2003	AYL B	249
2.0 TDI 4motion 12.2018 →	CXEC D	292	<b>SHARAN VAN (7N1, 7N2)</b>		
2.0 TSI 04.2015 →	CJKA B	321	1.4 TSI 05.2010 → 11.2015	CAVA B	80
2.0 TSI 04.2015 →	CJKB B	322	1.4 TSI 05.2012 → 11.2015	CTHA B	81
2.0 TSI 4motion 06.2015 →	CJKA B	321	2.0 TDI 05.2010 → 05.2011	CFFA D	272
<b>PASSAT B3/B4 (315, 3A5)</b>			2.0 TDI 05.2010 → 11.2015	CFFB D	272
1.8 10.1993 → 12.1996	AAM B	222	2.0 TDI 08.2010 → 01.2013	CFGB D	272
1.9 TD 10.1993 → 12.1996	AAZ D	137	2.0 TDI 05.2011 → 11.2015	CFFE D	287
2.0 08.1991 → 12.1995	2E B	297	2.0 TSI 12.2010 → 11.2015	CCZA B	313
2.0 Syncro 09.1989 → 10.1993	2E B	297	<b>T1 (Typ 2)</b>		
<b>PASSAT B7 Estate Van (365)</b>			Transporter 211 01.1960 → 08.1967	113 (34) B	117
1.4 TSi BlueMotion 08.2010 → 12.2014	CAXA B	78	Transporter 221 01.1960 → 08.1967	113 (34) B	117
1.6 TDi BlueMotion 08.2010 → 12.2014	CAYC D	181	<b>T2 (Typ 2)</b>		
1.8 TFSi 08.2010 → 12.2014	CDAA B	316	211 08.1967 → 12.1972	113 (34) B	117
2.0 TDi BlueMotion 08.2010 → 12.2014	CFFB D	272	221 08.1967 → 12.1972	113 (34) B	117
2.0 TDi BlueMotion 08.2010 → 12.2014	CFGB D	272	<b>T3 (EA 162)</b>		
2.0 TDi BlueMotion 08.2010 → 12.2014	CLLA D	287	2.4 08.1982 → 07.1992	DL B	47
2.0 TFSi 11.2010 → 12.2014	CCZB B	313	2.4 08.1983 → 07.1989	DW D	101
3.6 FSi 4motion 01.2011 → 12.2014	BWS B	385	2.4 08.1988 → 07.1992	1G D	111
<b>POLO Hatchback Van (86CF)</b>			2.4 08.1988 → 12.1995	1E B	48
1.0 08.1992 → 07.1994	AAU B	39	2.4 08.1988 → 12.1995	1S D	112
1.3 08.1992 → 07.1994	AAV B	40	2.4 08.1992 → 12.1995	ACL D	115
1.4 D 08.1992 → 07.1994	1W D	44	<b>TIGUAN SUV Van (AD1)</b>		
<b>POLO Van (6R)</b>			TDI BlueMotion 01.2016 → 07.2020	DFHA D	289
1.0 01.2014 →	CHYA B	20	<b>TIGUAN VAN (5N )</b>		
1.0 01.2014 →	CHYB B	20	1.4 TSI (5N1) 05.2008 → 05.2010	CAVA B	80
1.0 TSI 11.2014 →	CHZB B	19	1.4 TSI (5N1) 08.2010 → 05.2011	CAXA B	78
1.2 03.2009 → 05.2014	CGPB B	64	1.4 TSI (5N2) 09.2012 → 07.2018	CTHD B	80
1.2 BlueMotion 03.2009 → 05.2014	CGPA B	64	1.4 TSI 4motion (5N2) 09.2012 → 07.2018	CTHD B	80
1.2 TDi BlueMotion 10.2009 → 05.2014	CFWA D	183	2.0 TDI (5N1) 05.2010 → 07.2011	CFFD D	272
1.2 TSI 01.2014 →	CJZD B	15	2.0 TDI (5N1, 5N2) 11.2009 → 07.2018	CFFB D	272
1.2 TSI 02.2014 →	CJZC B	16	2.0 TDI 4motion (5N1, 5N2) 11.2007 → 07.2018	CBAB D	272
1.2 TSi 05.2011 → 05.2014	CBZC B	10	2.0 TDI 4motion (5N1, 5N2) 11.2009 → 07.2018	CFFB D	272
1.2 TSi BlueMotion 11.2009 → 05.2014	CBZB B	8	2.0 TDI 4motion (5N1, 5N2) 05.2010 → 05.2013	CFGB D	272
1.4 03.2009 → 05.2014	CGGB B	76	2.0 TDI 4motion (5N1, 5N2) 05.2011 → 07.2018	CLJA D	272
1.4 GTi 05.2010 → 05.2014	CAVE B	86	2.0 TDI 4motion (5N2) 11.2012 → 07.2018	CFGD D	272
1.4 TDI 02.2014 →	CUSB D	184	2.0 TSI 4motion (5N1) 11.2009 → 05.2011	CCZA B	313
1.4 TDI 03.2014 →	CUSA D	184	2.0 TSI 4motion (5N1) 11.2009 → 05.2011	CCZC B	317
1.4 TSI 05.2014 →	CZEA B	21	2.0 TSI 4motion (5N2) 05.2011 → 07.2018	CCZB B	313
1.6 TDi 06.2009 → 05.2014	CAYA D	182	<b>TIPO 1</b>		
1.6 TDi 06.2009 → 05.2014	CAYC D	181	1,6 05.1973 → 10.1992	AF B	377
1.6 TDi BlueMotion 06.2009 → 05.2014	CAYB D	181	<b>TOUAREG VAN (7P5)</b>		
<b>POLO Van Estate Van (6V5)</b>			3.0 TDI 4motion 05.2011 → 12.2014	CRCA D	357
1.4 08.1997 → 12.1999	AEX B	49	<b>TOURAN VAN (1T1, 1T2)</b>		
1.4 06.2000 → 09.2001	AUA B	56			
1.6 09.1997 → 12.1998	AEE B	53			
1.7 SDI 08.1997 → 12.1999	AKU D	148			

V

			Pos				Pos		
1.9 TDI	08.2003 → 02.2006	BKC	D	161	2.0	08.1975 → 04.1979	CJ	B	394
1.9 TDI	10.2003 → 05.2005	AVQ	D	169	2.0	08.1976 → 04.1979	GE	B	394
1.9 TDI	11.2004 → 05.2010	BRU	D	173	<b>TRANSPORTER II Platform/Chassis</b>				
1.9 TDI	11.2004 → 05.2010	BXF	D	174	1.6	08.1968 → 01.1973	AD	B	378
1.9 TDI	11.2004 → 05.2010	BXJ	D	175	1.6	01.1973 → 07.1979	AS	B	379
1.9 TDI	02.2006 → 11.2006	BXE	D	161	<b>TRANSPORTER II Van</b>				
2.0 EcoFuel	02.2006 → 11.2006	BSX	BG	295	1.6	08.1968 → 07.1979	B	B	376
2.0 FSI	05.2004 → 01.2007	BLR	B	308	1.6	08.1970 → 07.1973	AD	B	378
2.0 FSI	05.2004 → 01.2007	BLX	B	308	1.6	08.1973 → 07.1979	AS	B	379
2.0 FSI	05.2004 → 01.2007	BLY	B	308	1.7	08.1971 → 07.1973	CA	B	389
2.0 FSI	05.2004 → 01.2007	BVY	B	308	1.7	08.1971 → 12.1973	CB	B	389
2.0 FSI	05.2004 → 01.2007	BVZ	B	308	1.8	11.1973 → 07.1975	AP	B	392
2.0 TDI	02.2003 → 05.2010	AZV	D	267	2.0	08.1976 → 06.1977	GD	B	394
2.0 TDi	08.2003 → 05.2010	BKD	D	267	2.0	08.1976 → 06.1979	GE	B	394
2.0 TDi	12.2005 → 05.2010	BMM	D	271	2.0	08.1976 → 07.1979	CJ	B	394
FSI	02.2003 → 05.2004	BAG	B	68	<b>TRANSPORTER III Bus</b>				
FSI	05.2004 → 05.2005	BLP	B	69	1.6	05.1979 → 12.1982	CT	AB	382
FSI	01.2005 → 11.2006	BLF	B	69	1.6 D	01.1981 → 07.1987	CS	D	103
<b>TOURAN VAN (1T3)</b>					1.6 D	09.1981 → 12.1983	CS	D	103
1.2 TSI	05.2010 → 05.2015	CBZB	B	8	1.6 TD	08.1984 → 07.1992	JX	D	109
1.4 TSI	05.2010 → 05.2015	CAVB	B	77	1.6 TD Syncro	03.1986 → 07.1992	JX	D	109
1.4 TSI	05.2010 → 05.2015	CAVC	B	73	1.7 D	10.1986 → 07.1992	KY	D	133
1.4 TSI	05.2010 → 05.2015	CTHB	B	83	1.9	08.1982 → 07.1992	DF	B	396
1.4 TSI	05.2010 → 05.2015	CTHC	B	83	1.9	08.1982 → 07.1992	DG	B	397
1.4 TSi EcoFuel	05.2010 → 05.2015	CDGA	BG	45	1.9	01.1983 → 07.1985	DH	B	397
1.6 TDI	05.2010 → 05.2015	CAYB	D	181	1.9	08.1983 → 07.1985	GW	B	397
1.6 TDI	05.2010 → 05.2015	CAYC	D	181	1.9	09.1984 → 12.1985	DH	B	397
2.0 TDI	05.2010 → 05.2015	CFHC	D	272	1.9	08.1987 → 07.1989	SP	B	399
2.0 TDi	05.2010 → 01.2013	CFJA	D	272	1.9 Syncro	02.1985 → 07.1992	DG	B	397
<b>TRANSPORTER / CARAVELLE VI Bus (SGB, SGG, SGJ, SGC, SHB, SHJ)</b>					2.0	05.1979 → 12.1982	CU	B	394
2.0 TDI	04.2015 →	CAAA	D	272	2.0	05.1979 → 12.1982	CV	B	395
2.0 TDI	04.2015 →	CAAB	D	272	2.1	08.1984 → 07.1992	DJ	B	398
2.0 TDI	04.2015 →	CAAC	D	272	2.1	08.1985 → 07.1992	MV	B	398
2.0 TDI	04.2015 →	CFCA	D	288	2.1	09.1985 → 12.1988	MV	B	398
2.0 TDI	04.2015 →	CXFA	D	292	2.1	10.1986 → 07.1992	SR	B	398
2.0 TDI	04.2015 →	CXGA	D	292	2.1 Cat	06.1989 → 07.1992	MV	B	398
2.0 TDI	04.2015 →	CXGB	D	292	2.1 Syncro	08.1985 → 07.1992	MV	B	398
2.0 TDI	04.2015 →	CXHA	D	292	2.1 Syncro	01.1986 → 07.1992	DJ	B	398
2.0 TDI	06.2015 →	CXEB	D	292	2.1 Syncro	10.1986 → 07.1992	SR	B	398
2.0 TDI	05.2016 →	CXHB	D	292	2.1 i	07.1989 → 07.1992	SS	B	398
2.0 TDI	11.2018 →	CXEC	D	292	<b>TRANSPORTER III Platform/Chassis</b>				
2.0 TDI	07.2019 →	CXHC	D	292	1.6	04.1983 → 09.1990	CT	AB	382
2.0 TDI	10.2019 →	CXGD	D	292	1.6 D	01.1981 → 07.1987	CS	D	103
2.0 TDI 4motion	06.2015 →	CAAC	D	272	1.6 TD	10.1984 → 07.1992	JX	D	109
2.0 TDI 4motion	06.2015 →	CFCA	D	288	1.6 TD	08.1985 → 07.1987	JX	D	109
2.0 TDI 4motion	06.2015 →	CXEB	D	292	1.6 TD Syncro	03.1986 → 07.1992	JX	D	109
2.0 TDI 4motion	08.2015 →	CXFA	D	292	1.7 D	08.1985 → 07.1987	KY	D	133
2.0 TDI 4motion	08.2015 →	CXHA	D	292	1.7 D	07.1989 → 07.1992	KY	D	133
2.0 TDI 4motion	08.2018 →	CXEC	D	292	1.9	08.1982 → 07.1992	DG	B	397
2.0 TSI	04.2015 →	CJKA	B	321	1.9	09.1982 → 07.1992	DF	B	396
2.0 TSI	04.2015 →	CJKB	B	322	1.9	10.1984 → 02.1989	DH	B	397
2.0 TSI 4motion	06.2015 →	CJKA	B	321	1.9 Syncro	12.1984 → 07.1992	DG	B	397
<b>TRANSPORTER I Bus (22, 24, 25, 28)</b>					2.0	05.1979 → 04.1986	CU	B	394
1.5	11.1962 → 08.1966	H	B	347	2.1	08.1985 → 07.1992	MV	B	398
1.6	06.1966 → 07.1967	B	B	376	2.1	03.1986 → 07.1992	DJ	B	398
<b>TRANSPORTER I Platform/Chassis (26)</b>					2.1 Syncro	08.1985 → 07.1992	MV	B	398
1.5	06.1966 → 10.1970	H	B	347	2.1 Syncro	03.1986 → 07.1992	DJ	B	398
1.6	08.1964 → 12.1968	B	B	376	2.1 i	07.1989 → 07.1992	SS	B	398
<b>TRANSPORTER I Van (21, 23)</b>					<b>TRANSPORTER III Van</b>				
1.5	02.1962 → 12.1968	H	B	347	1.6	05.1979 → 12.1982	CT	AB	382
1.6	08.1964 → 12.1968	B	B	376	1.6	04.1983 → 09.1990	CT	AB	382
<b>TRANSPORTER II Bus</b>					1.6 D	01.1981 → 07.1987	CS	D	103
1.6	08.1967 → 07.1970	AF	B	377	1.6 TD	10.1984 → 07.1992	JX	D	109
1.6	08.1971 → 07.1973	AD	B	378	1.6 TD Syncro	03.1986 → 07.1992	JX	D	109
1.6	08.1973 → 04.1979	AS	B	379	1.7 D	08.1984 → 07.1992	KY	D	133
1.7	08.1971 → 07.1973	CA	B	389	1.9	10.1982 → 07.1992	DF	B	396
1.7	07.1973 → 10.1973	CB	B	389	1.9	10.1982 → 07.1992	DG	B	397
1.8	11.1973 → 07.1975	AP	B	392	1.9	08.1983 → 02.1989	GW	B	397
2.0	08.1975 → 06.1977	GD	B	394	1.9	10.1984 → 02.1989	DH	B	397

V

			Pos				Pos		
1.9 Syncro	11.1984 → 07.1992	DG	B	397	2.8	05.1996 → 05.2000	AES	B	233
2.0	05.1979 → 04.1986	CU	B	394	2.8 VR6	06.2000 → 04.2003	AMV	B	249
2.1	08.1985 → 07.1992	MV	B	398	<b>TRANSPORTER IV Van (70A, 70H, 7DA, 7DH)</b>				
2.1	03.1986 → 07.1992	DJ	B	398	1.8	12.1990 → 07.1992	PD	B	224
2.1 Syncro	08.1985 → 07.1992	MV	B	398	1.9 D	07.1990 → 12.1995	1X	D	135
2.1 Syncro	03.1986 → 07.1992	DJ	B	398	1.9 D	09.1990 → 12.1995	1X	D	135
2.1 i	07.1989 → 07.1992	SS	B	398	1.9 TD	10.1992 → 04.2003	ABL	D	139
<b>TRANSPORTER IV Bus (70B, 70C, 7DB, 7DK, 70J, 70K, 7DC, 7DJ)</b>				2.0	07.1990 → 04.2003	AAC	B	221	
1.8	12.1990 → 07.1992	PD	B	224	2.4 D	07.1990 → 04.1998	AAB	D	136
1.9 D	09.1990 → 12.1995	1X	D	135	2.4 D	08.1997 → 04.2003	AJA	D	154
1.9 D	09.1990 → 12.1995	1X	D	135	2.4 D Syncro	10.1992 → 09.1998	AAB	D	136
1.9 TD	10.1992 → 04.2003	ABL	D	139	2.5	11.1990 → 12.1993	AAF	B	219
2.0	09.1990 → 04.2003	AAC	B	221	2.5	11.1990 → 04.2003	AEN	B	219
2.4 D	09.1990 → 04.1998	AAB	D	136	2.5	11.1990 → 04.2003	AEU	B	223
2.4 D	08.1997 → 04.2003	AJA	D	154	2.5	01.1994 → 08.1996	ACU	B	219
2.4 D Syncro	10.1992 → 09.1998	AAB	D	136	2.5	08.1996 → 04.2003	AET	B	236
2.5	09.1990 → 06.2003	AEN	B	219	2.5	08.1996 → 04.2003	AVT	B	236
2.5	09.1990 → 06.2003	AEU	B	223	2.5	05.1999 → 04.2003	APL	B	247
2.5	11.1990 → 12.1993	AAF	B	219	2.5 Syncro	01.1996 → 10.1996	ACU	B	219
2.5	01.1994 → 08.1996	ACU	B	219	2.5 Syncro	08.1996 → 04.2003	AET	B	236
2.5	08.1996 → 04.2003	AET	B	236	2.5 Syncro	08.1996 → 04.2003	AVT	B	236
2.5	08.1996 → 04.2003	AVT	B	236	2.5 Syncro	06.1997 → 11.2001	AEU	B	223
2.5	05.1999 → 04.2003	APL	B	247	2.5 Syncro	05.1999 → 04.2003	APL	B	247
2.5 Syncro	08.1992 → 04.2003	AEU	B	223	2.5 TDI	09.1995 → 04.2003	ACV	D	259
2.5 Syncro	11.1992 → 12.1993	AAF	B	219	2.5 TDI	09.1995 → 04.2003	AUF	D	259
2.5 Syncro	01.1994 → 04.2003	ACU	B	219	2.5 TDI	09.1995 → 04.2003	AYC	D	259
2.5 Syncro	07.1996 → 04.2003	AVT	B	236	2.5 TDI	12.1998 → 04.2003	AJT	D	259
2.5 Syncro	08.1996 → 04.2003	AET	B	236	2.5 TDI	12.1998 → 04.2003	AYY	D	259
2.5 Syncro	05.1999 → 04.2003	APL	B	247	2.5 TDI	09.2000 → 04.2003	AHY	D	259
2.5 TDI	09.1995 → 04.2003	ACV	D	259	2.5 TDI	09.2000 → 04.2003	AXG	D	259
2.5 TDI	09.1995 → 04.2003	AUF	D	259	2.5 TDI Syncro	09.1995 → 04.2003	ACV	D	259
2.5 TDI	09.1995 → 04.2003	AYC	D	259	2.5 TDI Syncro	09.1995 → 04.2003	AXL	D	259
2.5 TDI	05.1998 → 04.2003	AHY	D	259	2.8 VR6	05.1996 → 05.2000	AES	B	233
2.5 TDI	05.1998 → 04.2003	AJT	D	259	2.8 VR6	06.2000 → 04.2003	AMV	B	249
2.5 TDI	05.1998 → 04.2003	AXG	D	259	<b>TRANSPORTER Passenger VAN</b>				
2.5 TDI	05.1998 → 04.2003	AYY	D	259	2.4 TDI	09.1992 → 12.1994	AAB	D	136
2.5 TDI Syncro	01.1996 → 04.2003	ACV	D	259	<b>TRANSPORTER V Bus (7HB, 7HJ, 7EB, 7EJ, 7EF, 7EG, 7HF, 7EC)</b>				
2.5 TDI Syncro	01.1996 → 04.2003	AXL	D	259	1.9 TDI	04.2003 → 11.2009	AXB	D	157
2.8 VR 6	11.1995 → 04.2000	AES	B	233	1.9 TDI	04.2003 → 11.2009	AXC	D	170
2.8 VR6	04.2000 → 04.2003	AMV	B	249	1.9 TDI	01.2006 → 11.2009	BRR	D	180
<b>TRANSPORTER IV Platform/Chassis (70E, 70L, 70M, 7DE, 7DL, 7D)</b>				1.9 TDI	06.2006 → 11.2009	BRS	D	180	
1.8	12.1990 → 07.1992	PD	B	224	2.0	11.2003 → 08.2015	AXA	BG	295
1.9 D	07.1990 → 12.1995	1X	D	135	2.0 BiTDI	09.2009 → 08.2015	CFCA	D	288
1.9 D	09.1990 → 12.1995	1X	D	135	2.0 BiTDI 4motion	09.2009 → 08.2015	CFCA	D	288
1.9 TD	10.1992 → 04.2003	ABL	D	139	2.0 CNG	01.2006 → 08.2015	AXA	BG	295
2.0	07.1990 → 04.2003	AAC	B	221	2.0 TDI	09.2009 → 08.2015	CAAA	D	272
2.4 D	09.1990 → 04.1998	AAB	D	136	2.0 TDI	09.2009 → 08.2015	CAAB	D	272
2.4 D	08.1997 → 04.2003	AJA	D	154	2.0 TDI	09.2009 → 08.2015	CAAC	D	272
2.4 D Syncro	10.1992 → 09.1998	AAB	D	136	2.0 TDI	09.2009 → 08.2015	CCHA	D	272
2.5	11.1990 → 12.1993	AAF	B	219	2.0 TDI	05.2010 → 08.2015	CAAE	D	272
2.5	11.1990 → 04.2003	AEN	B	219	2.0 TDI	05.2010 → 08.2015	CCHB	D	272
2.5	11.1990 → 04.2003	AEU	B	223	2.0 TDI	05.2011 → 08.2015	CAAD	D	272
2.5	01.1994 → 08.1996	ACU	B	219	2.0 TDI 4motion	09.2009 → 08.2015	CAAC	D	272
2.5	08.1996 → 04.2003	AET	B	236	2.0 TDI 4motion	09.2009 → 08.2015	CCHA	D	272
2.5	08.1996 → 04.2003	AVT	B	236	2.0 TDI 4motion	05.2010 → 08.2015	CAAE	D	272
2.5	05.1999 → 04.2003	APL	B	247	2.0 TDI 4motion	05.2010 → 08.2015	CCHB	D	272
2.5 Syncro	11.1992 → 12.1993	AAF	B	219	2.0 TSI	05.2011 → 08.2015	CJKA	B	321
2.5 Syncro	01.1994 → 10.1996	ACU	B	219	2.0 TSI	07.2012 → 08.2015	CJKB	B	322
2.5 Syncro	08.1996 → 04.2003	AET	B	236	2.0 TSI 4motion	07.2011 → 08.2015	CJKA	B	321
2.5 Syncro	08.1996 → 04.2003	AVT	B	236	2.5 TDI	04.2003 → 11.2009	AXD	D	265
2.5 Syncro	06.1997 → 11.2001	AEU	B	223	2.5 TDI	04.2003 → 11.2009	AXE	D	268
2.5 Syncro	05.1999 → 04.2003	APL	B	247	2.5 TDI	04.2003 → 11.2009	AXE	D	268
2.5 TDI	09.1995 → 04.2003	ACV	D	259	2.5 TDI	04.2003 → 11.2009	BNZ	D	266
2.5 TDI	09.1995 → 04.2003	AUF	D	259	2.5 TDI	04.2003 → 11.2009	BPC	D	266
2.5 TDI	09.1995 → 04.2003	AYC	D	259	2.5 TDI 4motion	07.2004 → 11.2009	AXD	D	265
2.5 TDI	05.1998 → 04.2003	AJT	D	259	2.5 TDI 4motion	07.2004 → 11.2009	AXE	D	268
2.5 TDI	05.1998 → 04.2003	AYY	D	259	2.5 TDI 4motion	07.2004 → 11.2009	BNZ	D	266
2.5 TDI Syncro	05.1998 → 04.2003	ACV	D	259	2.5 TDI 4motion	07.2004 → 11.2009	BPC	D	266
2.5 TDI Syncro	05.1998 → 04.2003	AXL	D	259	2.5 TDi	11.2003 → 11.2009	BLJ	D	265



				Pos					Pos
3.2 V6	02.2004 → 06.2004	BDL	B	364	3.2 4motion	11.2003 → 11.2009	CFLA	B	367
3.2 V6	02.2004 → 11.2009	BKK	B	364	3.2 V6	04.2003 → 06.2005	BDL	B	364
3.2 V6	02.2004 → 11.2009	CFLA	B	367	3.2 V6	02.2004 → 11.2009	BKK	B	364
3.2 V6 4motion	11.2003 → 11.2009	BDL	B	364	3.2 V6	02.2004 → 11.2009	CFLA	B	367
3.2 V6 4motion	11.2003 → 12.2009	BKK	B	364	3.2 V6 4motion	04.2003 → 06.2005	BDL	B	364
3.2 V6 4motion	05.2008 → 12.2009	CFLA	B	367	<b>TRANSPORTER VI Platform/Chassis (SFD, SFE, SFL, SFZ, SJD, SJ)</b>				
<b>TRANSPORTER V Platform/Chassis (7JD, 7JE, 7JL, 7JY, 7JZ, 7FD)</b>					2.0 TDI	04.2015 → 06.2016	CAAA	D	272
1.9 TDI	04.2003 → 11.2009	AXB	D	157	2.0 TDI	04.2015 → 06.2016	CXGA	D	292
1.9 TDI	04.2003 → 11.2009	AXC	D	170	2.0 TDI	04.2015 →	CAAB	D	272
1.9 TDI	01.2006 → 11.2009	BRR	D	180	2.0 TDI	04.2015 →	CAAC	D	272
1.9 TDI	06.2006 → 11.2009	BRS	D	180	2.0 TDI	04.2015 →	CFCA	D	288
2.0	11.2003 → 05.2013	AXA	BG	295	2.0 TDI	04.2015 →	CXGB	D	292
2.0 BiTDI	09.2009 → 08.2015	CFCA	D	288	2.0 TDI	08.2015 →	CXHA	D	292
2.0 BiTDI 4motion	09.2009 → 08.2015	CFCA	D	288	2.0 TDI	05.2016 →	CXEB	D	292
2.0 CNG	11.2003 → 05.2011	AXA	BG	295	2.0 TDI	05.2016 →	CXHB	D	292
2.0 TDI	09.2009 → 08.2015	CAAA	D	272	2.0 TDI	07.2019 →	CXHC	D	292
2.0 TDI	09.2009 → 08.2015	CAAB	D	272	2.0 TDI	08.2019 →	CXEC	D	292
2.0 TDI	09.2009 → 08.2015	CAAC	D	272	2.0 TDI	10.2019 →	CXGD	D	292
2.0 TDI	09.2009 → 08.2015	CCHA	D	272	2.0 TDI 4motion	06.2015 →	CAAC	D	272
2.0 TDI	05.2010 → 08.2015	CAAE	D	272	2.0 TDI 4motion	06.2015 →	CFCA	D	288
2.0 TDI	05.2011 → 08.2015	CAAD	D	272	2.0 TDI 4motion	05.2016 →	CXEB	D	292
2.0 TDI 4motion	09.2009 → 08.2015	CAAC	D	272	2.0 TDI 4motion	05.2016 →	CXHA	D	292
2.0 TDI 4motion	09.2009 → 08.2015	CCHA	D	272	2.0 TDI 4motion	08.2019 →	CXEC	D	292
2.0 TDI 4motion	05.2010 → 08.2015	CAAE	D	272	2.0 TSI	04.2015 →	CJKB	B	322
2.0 TDI 4motion	05.2010 → 08.2015	CCHB	D	272	<b>TRANSPORTER VI Van (SGA, SGH, SHA, SHH)</b>				
2.0 TSI	07.2012 → 08.2015	CJKB	B	322	2.0 TDI	04.2015 → 06.2016	CAAA	D	272
2.5 TDI	04.2003 → 11.2009	AXD	D	265	2.0 TDI	04.2015 → 06.2016	CXGA	D	292
2.5 TDI	04.2003 → 11.2009	AXE	D	268	2.0 TDI	04.2015 →	CAAB	D	272
2.5 TDI	04.2003 → 11.2009	BNZ	D	266	2.0 TDI	04.2015 →	CAAC	D	272
2.5 TDI	04.2003 → 11.2009	BPC	D	266	2.0 TDI	04.2015 →	CFCA	D	288
2.5 TDI 4motion	04.2004 → 11.2009	AXE	D	268	2.0 TDI	04.2015 →	CXFA	D	292
2.5 TDI 4motion	04.2004 → 11.2009	BPC	D	266	2.0 TDI	04.2015 →	CXGB	D	292
2.5 TDI 4motion	07.2004 → 11.2009	AXD	D	265	2.0 TDI	04.2015 →	CXHA	D	292
2.5 TDI 4motion	07.2004 → 11.2009	BNZ	D	266	2.0 TDI	06.2015 →	CXEB	D	292
3.2 4motion	11.2003 → 11.2009	BDL	B	364	2.0 TDI	05.2016 →	CXHB	D	292
3.2 V6	08.2003 → 05.2006	BKK	B	364	2.0 TDI	08.2018 →	CXEC	D	292
3.2 V6	02.2004 → 11.2009	BDL	B	364	2.0 TDI	07.2019 →	CXHC	D	292
<b>TRANSPORTER V Van (7HA, 7HH, 7EA, 7EH)</b>					2.0 TDI	10.2019 →	CXGD	D	292
1.9 TDI	04.2003 → 11.2009	AXB	D	157	2.0 TDI 4motion	06.2015 →	CAAC	D	272
1.9 TDI	04.2003 → 11.2009	AXC	D	170	2.0 TDI 4motion	06.2015 →	CFCA	D	288
1.9 TDI	01.2006 → 11.2009	BRR	D	180	2.0 TDI 4motion	06.2015 →	CXEB	D	292
1.9 TDI	06.2006 → 11.2009	BRS	D	180	2.0 TDI 4motion	08.2015 →	CXFA	D	292
2.0	11.2003 → 08.2015	AXA	BG	295	2.0 TDI 4motion	08.2015 →	CXHA	D	292
2.0 BiFuel	05.2011 → 08.2015	AXA	BG	295	2.0 TDI 4motion	08.2018 →	CXEC	D	292
2.0 BiTDI	09.2009 → 08.2015	CFCA	D	288	2.0 TSI	04.2015 →	CJKA	B	321
2.0 BiTDI 4motion	09.2009 → 08.2015	CFCA	D	288	2.0 TSI	04.2015 →	CJKB	B	322
2.0 TDI	09.2009 → 08.2015	CAAA	D	272	2.0 TSI 4motion	06.2015 →	CJKA	B	321
2.0 TDI	09.2009 → 08.2015	CAAB	D	272					
2.0 TDI	09.2009 → 08.2015	CAAC	D	272	<b>2000</b>				
2.0 TDI	09.2009 → 08.2015	CCHA	D	272	17.210	01.2000 →	6 BTAA	D	402
2.0 TDI	05.2010 → 08.2015	CAAE	D	272	<b>CONSTELLATION</b>				
2.0 TDI	05.2010 → 08.2015	CCHB	D	272	17.280	07.2005 →	D 0836 LFL 64	D	404
2.0 TDI	05.2011 → 08.2015	CAAD	D	272	17.310 TITAN	04.2006 → 06.2008	6 CTAA 8.3	D	406
2.0 TDI 4motion	09.2009 → 08.2015	CAAC	D	272	18.310 TITAN	04.2006 → 06.2008	6 CTAA 8.3	D	406
2.0 TDI 4motion	09.2009 → 08.2015	CCHA	D	272	24.280	07.2005 →	D 0836 LFL 64	D	404
2.0 TDI 4motion	05.2010 → 08.2015	CAAE	D	272	26.280	01.2017 →	D 0836 LFL 64	D	404
2.0 TDI 4motion	05.2010 → 08.2015	CCHB	D	272	26.310 TITAN	04.2006 → 06.2008	6 CTAA 8.3	D	406
2.0 TSI	05.2011 → 08.2015	CJKA	B	321	<b>DELIVERY</b>				
2.0 TSI	07.2012 → 08.2015	CJKB	B	322	6.80	01.1982 → 10.1986	4.236	D	401
2.0 TSI 4motion	07.2011 → 08.2015	CJKA	B	321	6.90	01.1983 → 10.1986	4.236	D	401
2.5 TDI	04.2003 → 11.2009	AXD	D	265	<b>DELIVERY II</b>				
2.5 TDI	04.2003 → 11.2009	AXE	D	268	4160	01.2018 →	ISF2.8	D	400
2.5 TDI	04.2003 → 11.2009	BNZ	D	266	6.160	01.2018 →	ISF2.8	D	400
2.5 TDI	04.2003 → 11.2009	BPC	D	266	Express	01.2018 →	ISF2.8	D	400
2.5 TDI 4motion	07.2004 → 11.2009	AXD	D	265	<b>VOLKSBUS</b>				
2.5 TDI 4motion	07.2004 → 11.2009	AXE	D	268	14.190 OD	12.2017 →	D 0834 LFL 64	D	404
2.5 TDI 4motion	07.2004 → 11.2009	BNZ	D	266	15.190 OD	01.2014 → 12.2015	D 0834 LFL 64	D	404
2.5 TDI 4motion	07.2004 → 11.2009	BPC	D	266	15.190 OD	01.2016 →	D 0834 LFL 64	D	404
3.2 4motion	11.2003 → 11.2009	BKK	B	364					

V

			Pos				Pos
17.230 OD	01.2014 → 12.2015	D 0834 LFL 65	D	404			
17.230 OD	01.2016 →	D 0834 LFL 65	D	404			
17.280 OT	01.2014 → 12.2015	D 0836 LOH 64	D	404			
17.280 OT	01.2016 →	D 0836 LOH 64	D	404			
18.280 OT	01.2017 →	D 0836 LOH 64	D	404			
18.280 OT	01.2018 →	D 0836 LOH 64	D	404			
18.310 OT	09.2005 →	6 CTAA 8.3	D	406			
18.310 OT	09.2005 →	6 CTAA 8.3	D	406			
8.150 FEB	01.2013 → 12.2015	D 0834 LFL 63	D	404			
8.150 FEB	12.2015 →	D 0834 LFL 63	D	404			
9.150 FEB	01.2013 → 12.2015	D 0834 LFL 63	D	404			
9.150 FEB	01.2016 →	D 0834 LFL 63	D	404			
<b>WORKER</b>							
12.170	11.1998 →	6 BTAA	D	402			
14.170	11.1998 →	6 BTAA	D	402			
14.210	01.1989 →	6 CT 8.3	D	405			
14.220	11.1998 →	6 CT 8.3	D	405			
15.170	01.2001 → 08.2002	6 BTAA	D	402			
15.190	01.2015 →	D 0834 LFL 64	D	404			
16.170	05.1998 →	6 BTAA	D	402			
16.200	05.1998 →	6 BTAA	D	402			
16.210	02.1988 → 02.2000	6 CT 8.3	D	405			
16.300	05.1998 →	6 CTAA 8.3	D	406			
17.160	03.2000 → 04.2001	6 BTAA	D	402			
17.210	01.2005 → 10.2007	6 BTAA	D	402			
17.220	09.2005 →	6 CT 8.3	D	405			
17.230	01.2016 →	D 0834 LFL 65	D	404			
17.250	07.2005 → 12.2014	ISB-250	D	403			
17.300	08.1999 → 09.2004	6 CTAA 8.3	D	406			
23.210	05.2001 → 12.2005	6 BTAA	D	402			
23.310	05.2001 → 12.2005	6 CTAA 8.3	D	406			
24.220	04.2006 → 12.2011	6 CT 8.3	D	405			
24.250	07.2005 → 12.2014	ISB-250	D	403			
26.300	01.2000 → 10.2001	6 CTAA 8.3	D	406			
26.300	01.2001 → 10.2003	6 CTAA 8.3	D	406			
31.310	12.2004 → 12.2006	6 CTAA 8.3	D	406			
35.250	01.1991 →	6 CTAA 8.3	D	406			
35.300	11.1998 →	6 CTAA 8.3	D	406			
40.300	06.1999 → 11.2001	6 CTAA 8.3	D	406			
8.150	07.2005 → 12.2016	D 0834 LFL 63	D	404			
9.150	07.2005 → 12.2016	D 0834 LFL 63	D	404			



					Reference	Item No.		
<b>1</b>		<b>67,1</b>						
<b>AER</b>	08.1996 → 07.2005	B (NA)	4	999 cm <sup>3</sup>	2V	37 kW (50 PS) 10,5	70,60 mm	
<b>ALL</b>	09.1996 → 07.2005	B (NA)	4	999 cm <sup>3</sup>	2V	37 kW (50 PS) 10,7	70,60 mm	
99 679 6..								
	IN [2] EX [2]	31,0 x 7 x 94,7 26,0 x 7 x 94,4	S - - A/S - -	- 45° - - - 45° - VS -	22 - III 22 - III	030 109 601 AG 030 109 611 N	<b>39542</b> <b>39515</b>	
	[50]	∅ 7 mm				021 109 651	<b>MK-7H</b>	
	IN/EX [4] IN/EX [4]	11,08/15 x 7 x 33,0 11,28/15 x 7 x 33,0	B1 B1			032 103 419 A	<b>81-33109</b> <b>81-33110</b>	
						030 109 101 BG	<b>50 006 381</b> (1)	
(1) Schalenhartguss/chilled cast iron/pièce moulée trempée en surface/fundición en coquilla/Отливка с отбеленным поверхностным слоем								
	[8]	H 35 x 26 x 26				050 109 309 050 109 309 A 050 109 309 H 050 109 309 J	<b>50 006 417</b>	
<b>2</b>		<b>67,1</b>						
<b>ALD</b>	09.1998 → 07.2005	B (NA)	4	999 cm <sup>3</sup>	2V	37 kW (50 PS) 10,7	70,60 mm	
<b>ANV</b>	09.1998 → 07.2005	B (NA)	4	999 cm <sup>3</sup>	2V	37 kW (50 PS) 10,7	70,60 mm	
<b>AUC</b>	09.1998 → 07.2005	B (NA)	4	999 cm <sup>3</sup>	2V	37 kW (50 PS) 10,7	70,60 mm	
	IN [2] EX [2]	31,0 x 6 x 99,0 26,0 x 6 x 99,0	S - - A/S - Cr -	- 45° - - - 45° - VS -	22 - III 22 - III	030 109 601AK 030 109 611S	<b>331139</b> <b>331140</b>	
	IN/EX [4] IN/EX [4] IN/EX [4] EX [4]	11,04 x 6 x 39,0 11,05 x 6 x 36,0 11,15 x 6 x 36,0 11,04 x 6 x 39,0	B1 B1 B1 G2			058 103 415	<b>81-33121</b> <b>81-33111</b> <b>81-33118</b> <b>81-33122</b>	
	[8]	H 12 x 34,8 x 34,8				030 109 423 030 109 423 A 030 109 423 B 036 109 423 A 036 109 423 D CP40239	<b>50 006 415</b>	
	[4]					030 109 417 D	<b>50 006 141</b>	
<b>3</b>		<b>67,1</b>						
<b>ATE</b>			B (NA)	4	999 cm <sup>3</sup>	2V	37 kW (50 PS) 10,7:1	70,60 mm
	IN [2] EX [2]	31,0 x 6 x 99,0 26,0 x 6 x 99,0	S - - A/S - Cr -	- 45° - - - 45° - VS -	22 - III 22 - III	030 109 601AK 030 109 611S	<b>331139</b> <b>331140</b>	
	IN/EX [4] IN/EX [4] IN/EX [4] EX [4]	11,04 x 6 x 39,0 11,05 x 6 x 36,0 11,15 x 6 x 36,0 11,04 x 6 x 39,0	B1 B1 B1 G2			058 103 415	<b>81-33121</b> <b>81-33111</b> <b>81-33118</b> <b>81-33122</b>	
<b>4</b>		<b>67,1</b>						
<b>AQZ</b>	08.2003 → 12.2009	B (NA)	4	999 cm <sup>3</sup>	2V	53 kW (72 PS) 10,8	70,60 mm	
<b>AZN</b>	06.2002 → 05.2010	B (NA)	4	999 cm <sup>3</sup>	2V	40-48 kW (54-65 PS) 10,5	70,60 mm	
<b>BNX</b>	05.2009 → 10.2014	B (NA)	4	999 cm <sup>3</sup>	2V	53-56 kW (72-76 PS) 10,8	70,60 mm	
<b>BTY</b>	02.2005 → 05.2010	B (NA)	4	999 cm <sup>3</sup>	2V	48-53 kW (65-72 PS)	70,60 mm	
<b>CCNA</b>	03.2008 →	B (NA)	4	999 cm <sup>3</sup>	2V	51-56 kW (69-76 PS) 10,8	70,60 mm	
Fortsetzung nächste Seite / continued on next page / suite page suivante / continuación página próxima / Продолжение на следующей странице								

V

					Reference	Item No.
[4]					030 109 411 030 109 411B	<b>50 006 140</b>
<b>5</b>	<b>67,1</b>					
<b>BJE KAT</b>	08.2003 → 12.2009	AB (NA)	4	999 cm <sup>3</sup> 2V	52-53 kW (71-72 PS) 10,8	70,60 mm
<b>BNW</b>	10.2005 → 12.2014	AB (NA)	4	999 cm <sup>3</sup> 2V	50-53 kW (68-72 PS)	70,60 mm
[4]					030 109 411 030 109 411B	<b>50 006 140</b>
<b>6</b>	<b>69,5</b>					
<b>FA</b>	04.1974 → 07.1983	B (NA)	4	1093 cm <sup>3</sup> 2V	37 kW (50 PS) 8	72,00 mm
<b>FJ</b>	08.1976 → 07.1980	B (NA)	4	1093 cm <sup>3</sup> 2V	38 kW (52 PS) 9,7	72,00 mm
<b>GG</b>	04.1974 → 02.1984	B (NA)	4	1093 cm <sup>3</sup> 2V	37 kW (50 PS) 9,7	72,00 mm
<b>HA</b>	09.1975 → 12.1981	B (NA)	4	895 cm <sup>3</sup> 2V	29 kW (40 PS) 8	59,00 mm
<b>HB</b>	03.1975 → 09.1989	B (NA)	4	1093 cm <sup>3</sup> 2V	37 kW (50 PS) 8,2	72,00 mm
<b>HC</b>	03.1975 → 09.1981	B (NA)	4	1093 cm <sup>3</sup> 2V	44 kW (60 PS) 9,5	72,00 mm
IN/EX [4]	12,06/15 x 8 x 36,5	B1			056 103 419 A	<b>81-3310</b>
IN/EX [4]	12,13/15 x 8 x 36,5	B1				<b>81-3312</b>
IN/EX [4]	12,20/15 x 8 x 36,5	B1				<b>81-3311</b>
<b>7</b>	<b>69,5</b>					
<b>HD</b>	02.1977 → 09.1981	B (NA)	4	1093 cm <sup>3</sup> 2V	38 kW (52 PS) 8,2:1	72,00 mm
[50]	∅ 8 mm				056 109 651	<b>RK-8</b>
IN/EX [4]	12,06/15 x 8 x 36,5	B1			056 103 419 A	<b>81-3310</b>
IN/EX [4]	12,13/15 x 8 x 36,5	B1				<b>81-3312</b>
IN/EX [4]	12,20/15 x 8 x 36,5	B1				<b>81-3311</b>
<b>8</b>	<b>71</b>					
<b>CBZB Euro 5</b>	11.2008 →	B (A)	4	1197 cm <sup>3</sup> 2V	77 kW (105 PS) 10	75,60 mm
41 257 6..						
IN [2]	35,5 x 6 x 98,7	S - -	- 45° - -	22 - III	03F 109 601A	<b>331153</b>
EX [2]	30,0 x 6 x 98,4	RA/S- Cr -	- 45° - VS -	22 - III		<b>331161</b> <small>NEW</small> (1)
EX [2]	30,0 x 6 x 98,4	RA/S- Cr - Na	- 45° - VS -	22 - III	03F 109 611B 03F 109 611C	<b>331155</b> (2)
(1)	IAM specification					
(2)	OES specification					
[50]	∅ 6 mm				036 109 651A	<b>MK-6H</b>
IN/EX [4]	11,04 x 6 x 39,0	B1				<b>81-33121</b> <small>NEW</small>
IN/EX [4]	11,05 x 6 x 36,0	B1			058 103 415	<b>81-33111</b>
IN/EX [4]	11,15 x 6 x 36,0	B1				<b>81-33118</b> <small>NEW</small>
EX [4]	11,04 x 6 x 39,0	G2				<b>81-33122</b> <small>NEW</small>
					03F 109 101 D	<b>50 007 677</b> (3)
(3)	Schalenhartguss/chilled cast iron/pièce moulée trempée en surface/fundición en coquilla/Отливка с отбелсным поверхностным слоем					
[8]	H 12 x 34,8 x 34,8				030 109 423 030 109 423 A 030 109 423 B 036 109 423 A 036 109 423 D CP40239	<b>50 006 415</b>
[8]					03F109411	<b>50 007 642</b>

					Reference	Item No.	
<b>9</b>	<b>71</b>	<b>CBZA</b> 05.2010 → 05.2015 B (A) 4 1197 cm <sup>3</sup> 2V 63 kW (86 PS) 10 75,60 mm					41 257 6..
	IN [2] EX [2] EX [2]	35,5 x 6 x 98,7 30,0 x 6 x 98,4 30,0 x 6 x 98,4	S - - RA/S- Cr - RA/S- Cr - Na	- 45° - - - 45° - VS - - 45° - VS -	22 - III 22 - III 22 - III	03F 109 601A 03F 109 611B 03F 109 611C	<b>331153</b> <b>331161</b> (1) <b>331155</b> (2)
	(1) IAM specification (2) OES specification						
	IN/EX [4] IN/EX [4] IN/EX [4] EX [4]	11,04 x 6 x 39,0 11,05 x 6 x 36,0 11,15 x 6 x 36,0 11,04 x 6 x 39,0	B1 B1 B1 G2			058 103 415	<b>81-33121</b> <b>81-33111</b> <b>81-33118</b> <b>81-33122</b>
						03F 109 101 D	<b>50 007 677</b> (3)
	(3) Schalenhartguss/chilled cast iron/pièce moulée trempée en surface/fundición en coquilla/Отливка с отбеленным поверхностным слоем						
	[8]	H 12 x 34,8 x 34,8				030 109 423 030 109 423 A 030 109 423 B 036 109 423 A 036 109 423 D CP40239	<b>50 006 415</b>
	[8]					03F109411	<b>50 007 642</b>
<b>10</b>	<b>71</b>	<b>CBZC</b> 05.2011 → 05.2014 B (A) 4 1197 cm <sup>3</sup> 2V 66 kW (90 PS) 10,0:1 75,60 mm					41 257 6..
	IN [2] EX [2] EX [2]	35,5 x 6 x 98,7 30,0 x 6 x 98,4 30,0 x 6 x 98,4	S - - RA/S- Cr - RA/S- Cr - Na	- 45° - - - 45° - VS - - 45° - VS -	22 - III 22 - III 22 - III	03F 109 601A 03F 109 611B 03F 109 611C	<b>331153</b> <b>331161</b> (1) <b>331155</b> (2)
	(1) IAM specification (2) OES specification						
	IN/EX [4] IN/EX [4] IN/EX [4] EX [4]	11,04 x 6 x 39,0 11,05 x 6 x 36,0 11,15 x 6 x 36,0 11,04 x 6 x 39,0	B1 B1 B1 G2			058 103 415	<b>81-33121</b> <b>81-33111</b> <b>81-33118</b> <b>81-33122</b>
	[8]					03F109411	<b>50 007 642</b>
<b>11</b>	<b>71</b>	<b>CJZB Euro 5</b> 08.2012 → B (LA) 4 1197 cm <sup>3</sup> 4V 63 kW (86 PS) 10,5 75,60 mm					
	IN [2] EX [2]	26,5 x 5 x 110,2 23,5 x 5 x 110,1	S - - RA/S- Cr -	- 45° - - - 30° - VS -	22 - III 22 - III	04E 109 601A 04E 109 611K	<b>331156</b> <b>331157</b>
	[50]	∅ 5 mm					<b>MK-5H</b>
	IN/EX [4] IN/EX [4] IN [1] EX [4] EX [1]	11,04 x 6 x 39,0 11,15 x 6 x 36,0 10,06 x 5 x 45,0 11,04 x 6 x 39,0 10,05 x 5 x 45,0	B1 B1 B1 G2 G2				<b>81-33121</b> <b>81-33118</b> <b>81-33123</b> <b>81-33122</b> <b>81-33124</b>

Fortsetzung nächste Seite / continued on next page / suite page suivante / continuación página próxima / Продолжение на следующей странице

					Reference	Item No.	
[8]	H 12				04E109423C	50 007 667	
[4]					04E109411AA 04E109411J	50 007 668	
<b>12</b>							
<b>CYVA Euro 6</b>	08.2012 →	B (LA)	4	1197 cm <sup>3</sup>	4V 63 kW (86 PS)	10,5 75,60 mm	
<b>CYVB</b>	04.2014 →	B (LA)	4	1197 cm <sup>3</sup>	4V 81 kW (110 PS)	10,5 75,60 mm	
IN [2] EX [2]	26,5 x 5 x 110,2 23,5 x 5 x 110,1	S - - RA/S- Cr -		- 45° - - 30° - VS -	22 - III 22 - III	04E 109 601A 04E 109 611K	331156 331157
[50]	∅ 5 mm						MK-5H
IN/EX [4] IN/EX [4] IN [1] EX [1]	11,04 x 6 x 39,0 11,15 x 6 x 36,0 10,06 x 5 x 45,0 10,05 x 5 x 45,0	B1 B1 B1 G2					81-33121 81-33118 81-33123 81-33124
[4]					04E109411AA 04E109411J		50 007 668
<b>13</b>							
<b>CJZA</b>	11.2012 →	B (LA)	4	1197 cm <sup>3</sup>	4V 77 kW (105 PS)	10,5 75,60 mm	
IN [2] EX [2]	26,5 x 5 x 110,2 23,5 x 5 x 110,1	S - - RA/S- Cr -		- 45° - - 30° - VS -	22 - III 22 - III	04E 109 601A 04E 109 611K	331156 331157
[50]	∅ 5 mm						MK-5H
IN/EX [4] IN/EX [4] IN [1] EX [1]	11,04 x 6 x 39,0 11,15 x 6 x 36,0 10,06 x 5 x 45,0 10,05 x 5 x 45,0	B1 B1 B1 G2					81-33121 81-33118 81-33123 81-33124
[8]	H 12				04E109423C		50 007 667
<b>14</b>							
<b>CYVC</b>	06.2015 →	B (A)	4	1197 cm <sup>3</sup>	4V 62 kW (84 PS)	75,60 mm	
<b>CYVD</b>	11.2013 →	B (A)	4	1197 cm <sup>3</sup>	4V 77 kW (105 PS)	75,60 mm	
IN [2] EX [2]	26,5 x 5 x 110,2 23,5 x 5 x 110,1	S - - RA/S- Cr -		- 45° - - 30° - VS -	22 - III 22 - III	04E 109 601A 04E 109 611K	331156 331157
[50]	∅ 5 mm						MK-5H
<b>15</b>							
<b>CJZD Euro 6</b>	01.2014 →	B (LA)	4	1197 cm <sup>3</sup>	4V 81 kW (110 PS)	10,5 75,60 mm	
IN [2] EX [2]	26,5 x 5 x 110,2 23,5 x 5 x 110,1	S - - RA/S- Cr -		- 45° - - 30° - VS -	22 - III 22 - III	04E 109 601A 04E 109 611K	331156 331157
[50]	∅ 5 mm						MK-5H
IN/EX [4] IN/EX [4]	11,04 x 6 x 39,0 11,15 x 6 x 36,0	B1 B1					81-33121 81-33118

V

					Reference	Item No.	
<b>16</b>		<b>71</b>					
<b>CJZC Euro 6</b>	02.2014 →	B (A)	4	1197 cm <sup>3</sup> 4V	66 kW (90 PS)	10,5 75,60 mm	
	IN [2] EX [2]	26,5 x 5 x 110,2 23,5 x 5 x 110,1	S - - RA/S- Cr -	- 45° - - - 30° - VS -	22 - III 22 - III	04E 109 601A 04E 109 611K	<b>331156</b> <b>331157</b>
	[50]	∅ 5 mm					<b>MK-5H</b>
	[8]	H 12				04E109423C	<b>50 007 667</b>
	[4]					04E109411AA 04E109411J	<b>50 007 668</b>
<b>17</b>		<b>74,5</b>					
<b>CPWA</b>	06.2013 →	BG (A)	4	1395 cm <sup>3</sup> 4V	81 kW (110 PS)	10,5 80,00 mm	
	IN [2] EX [2]	28,5 x 5 x 110,2 25,0 x 5 x 110,1	S - Ni - RA/S- Ni -	- 45° - VS - - 30° - VS -	22 - III 22 - III	04E 109 601 P 04C 109 611C 04E 109 611AC 04E 109 611AJ	<b>331163</b> <b>331164</b>
	[50]	∅ 5 mm					<b>MK-5H</b>
	[4]					04E109411AA 04E109411J	<b>50 007 668</b>
<b>18</b>		<b>74,5</b>					
<b>DBYA Euro 6</b>	09.2017 →	BG (A)	3	999 cm <sup>3</sup> 4V	66 kW (90 PS)	10,5 76,40 mm	
	IN [2] EX [2]	28,5 x 5 x 110,2 25,0 x 5 x 110,1	S - - RA/S- Ni -	- 45° - - - 30° - VS -	22 - III 22 - III	04E 109 601B 04C 109 611C 04E 109 611AC 04E 109 611AJ	<b>331158</b> <b>331164</b>
	[50]	∅ 5 mm					<b>MK-5H</b>
<b>19</b>		<b>74,5</b>					
<b>CHZA</b>	05.2016 → 09.2018	B (A)	3	999 cm <sup>3</sup> 4V	66 kW (90 PS)	76,40 mm	
<b>CHZB Euro 6</b>	11.2014 →	B (A)	3	999 cm <sup>3</sup> 4V	70 kW (95 PS)	10,5 76,40 mm	
<b>CHZC Euro 6</b>	11.2014 →	B (A)	3	999 cm <sup>3</sup> 4V	81 kW (110 PS)	10,5 76,40 mm	
<b>CHZG</b>	11.2015 →	B (LA)	3	999 cm <sup>3</sup> 4V	75 kW (102 PS)	76,40 mm	
<b>CHZK</b>	01.2017 →	B (A)	3	999 cm <sup>3</sup> 4V	63 kW (86 PS)	76,40 mm	
<b>CHZL</b>	06.2017 →	B (A)	3	999 cm <sup>3</sup> 4V	70 kW (95 PS)	10,5 76,40 mm	
<b>CNLA</b>	04.2011 →	B (LA)	4	1395 cm <sup>3</sup> 4V	110 kW (150 PS)	10,5 80,00 mm	
<b>CRJA</b>	04.2011 →	B (LA)	4	1395 cm <sup>3</sup> 4V	110 kW (150 PS)	10,5 80,00 mm	
<b>CUKA Euro 6</b>		B (LA)	4	1395 cm <sup>3</sup> 4V	90 kW (122 PS)	80,00 mm	
<b>CUKB Euro 6</b>	05.2014 →	B (LA)	4	1395 cm <sup>3</sup> 4V	110 kW (150 PS)	10 80,00 mm	
<b>CUKC Euro 6</b>	06.2015 →	B (LA)	4	1395 cm <sup>3</sup> 4V	115 kW (156 PS)	80,00 mm	
<b>CZCA Euro 6</b>	11.2013 →	B (LA)	4	1395 cm <sup>3</sup> 4V	92 kW (125 PS)	10 80,00 mm	
<b>CZCB</b>	05.2015 →	B (A)	4	1395 cm <sup>3</sup> 4V	92 kW (125 PS)	10,5 80,00 mm	
<b>CZDA Euro 6</b>	11.2013 →	B (LA)	4	1395 cm <sup>3</sup> 4V	110 kW (150 PS)	10 80,00 mm	
<b>CZDB</b>	05.2015 → 07.2018	B (A)	4	1395 cm <sup>3</sup> 4V	92 kW (125 PS)	80,00 mm	
<b>CZDC</b>	07.2015 → 11.2017	B (A)	4	1395 cm <sup>3</sup> 4V	96 kW (130 PS)	10 80,00 mm	
<b>CZDD</b>	05.2014 → 03.2017	B (A)	4	1395 cm <sup>3</sup> 4V	92 kW (125 PS)	80,00 mm	
<b>CZTA</b>	08.2014 →	B (A)	4	1395 cm <sup>3</sup> 4V	110 kW (150 PS)	10 80,00 mm	
	IN [2] EX [2]	28,5 x 5 x 110,2 25,0 x 5 x 110,1	S - - RA/S- Cr -	- 45° - - - 30° - VS -	22 - III 22 - III	04E 109 601B 04E 109 611H 04E 109 611J	<b>331158</b> <b>331159</b>
	[50]	∅ 5 mm					<b>MK-5H</b>

V

					Reference	Item No.
<b>20</b>	<b>74,5</b>					
<b>CHYA Filter</b>	08.2011 →	B (NA)	3	999 cm <sup>3</sup> 4V	44 kW (60 PS)	76,40 mm
<b>CHYB Filter</b>	08.2011 →	B (NA)	3	999 cm <sup>3</sup> 4V	55 kW (75 PS) 10,5	76,40 mm
41 272 6..						
	IN [2]	29,6 x 5 x 110,2	S - -	- 45° - -	22 - III	04C 109 601C 04E 109 601
	EX [2]	27,0 x 5 x 110,1	A/S - Cr -	- 30° - VS -	22 - III	04C 109 611A 04E 109 611L
	[50]	∅ 5 mm				<b>MK-5H</b>
	IN [1]	10,06 x 5 x 45,0	B1			<b>81-33123</b>
	EX [1]	10,05 x 5 x 45,0	G2			<b>81-33124</b>
	[8]	H 12			04E109423C	<b>50 007 667</b>
	[4]				04E109411AA 04E109411J	<b>50 007 668</b>
<b>21</b>	<b>74,5</b>					
<b>CHYC Filter</b>	08.2017 →	B (NA)	3	999 cm <sup>3</sup> 4V	48 kW (65 PS)	76,40 mm
<b>CZEA Euro 6</b>	05.2014 →	B (LA)	4	1395 cm <sup>3</sup> 4V	110 kW (150 PS) 10	80,00 mm
<b>DAFA</b>	08.2011 → 08.2020	B (NA)	3	999 cm <sup>3</sup> 4V	44 kW (60 PS)	76,40 mm
<b>DFNA Euro 6</b>	09.2018 →	B (LA)	3	999 cm <sup>3</sup> 4V	59 kW (80 PS)	76,40 mm
<b>DFNB Euro 6</b>	08.2017 →	B (LA)	3	999 cm <sup>3</sup> 4V	48 kW (65 PS)	76,40 mm
<b>DSGB Euro 6</b>	09.2018 →	B (LA)	3	999 cm <sup>3</sup> 4V	59 kW (80 PS)	76,40 mm
41 272 6..						
	IN [2]	29,6 x 5 x 110,2	S - -	- 45° - -	22 - III	04C 109 601C 04E 109 601
	EX [2]	27,0 x 5 x 110,1	A/S - Cr -	- 30° - VS -	22 - III	04C 109 611A 04E 109 611L
	[50]	∅ 5 mm				<b>MK-5H</b>
	IN [1]	10,06 x 5 x 45,0	B1			<b>81-33123</b>
	EX [1]	10,05 x 5 x 45,0	G2			<b>81-33124</b>
<b>22</b>	<b>74,5</b>					
<b>CHPA Euro 5</b>	08.2012 →	B (LA)	4	1395 cm <sup>3</sup> 4V	103 kW (140 PS) 10,5	80,00 mm
<b>CHPB Euro 6</b>	11.2013 →	B (LA)	4	1395 cm <sup>3</sup> 4V	110 kW (150 PS) 10	80,00 mm
<b>CMBA Euro 5</b>	11.2012 →	B (LA)	4	1395 cm <sup>3</sup> 4V	90 kW (122 PS) 10	80,00 mm
<b>CXSA Euro 5</b>	11.2012 →	B (LA)	4	1395 cm <sup>3</sup> 4V	90 kW (122 PS) 10,5	80,00 mm
	IN [2]	28,5 x 5 x 110,2	S - -	- 45° - -	22 - III	04E 109 601B
	EX [2]	25,0 x 5 x 110,1	RA/S- Cr -	- 30° - VS -	22 - III	04E 109 611H 04E 109 611J
	[50]	∅ 5 mm				<b>MK-5H</b>
	[8]	H 12			04E109423C	<b>50 007 667</b>
	[4]				04E109411AA 04E109411J	<b>50 007 668</b>
<b>23</b>	<b>74,5</b>					
<b>CPTA Euro 5</b>	08.2012 →	B (LA)	4	1395 cm <sup>3</sup> 4V	103 kW (140 PS) 10,5	80,00 mm
Fortsetzung nächste Seite / continued on next page / suite page suivante / continuación página próxima / Продолжение на следующей странице						



					Reference	Item No.
IN [2] EX [2]	28,5 x 5 x 110,2 25,0 x 5 x 110,1	S - - RA/S- Cr -	- 45° - - - 30° - VS -	22 - III 22 - III	04E 109 601B 04E 109 611H 04E 109 611J	<b>331158</b> <b>331159</b>
[50]	Ø 5 mm					<b>MK-5H</b>
IN [1] EX [1]	10,06 x 5 x 45,0 10,05 x 5 x 45,0	B1 G2				<b>81-33123</b> <b>81-33124</b>

## 24 74,5

<b>CPVA Euro 5</b>	04.2013 →	B (LA) 4	1395 cm <sup>3</sup> 4V	90 kW	(122 PS) 10,5	80,00 mm
<b>CXSB Euro 6</b>	11.2013 → 11.2017	B (LA) 4	1395 cm <sup>3</sup> 4V	92 kW	(125 PS) 10	80,00 mm
IN [2] EX [2]	28,5 x 5 x 110,2 25,0 x 5 x 110,1	S - Ni - RA/S- Ni -	- 45° - VS - - 30° - VS -	22 - III 22 - III	04E 109 601 P 04C 109 611C 04E 109 611AC 04E 109 611AJ	<b>331163</b> <b>331164</b>
[50]	Ø 5 mm					<b>MK-5H</b>
[8]	H 12				04E109423C	<b>50 007 667</b>
[4]					04E109411AA 04E109411J	<b>50 007 668</b>

## 25 74,5

<b>CPVB Euro 6</b>	12.2013 →	B (LA) 4	1395 cm <sup>3</sup> 4V	92 kW	(125 PS) 10	80,00 mm
IN [2] EX [2]	28,5 x 5 x 110,2 25,0 x 5 x 110,1	S - Ni - RA/S- Ni -	- 45° - VS - - 30° - VS -	22 - III 22 - III	04E 109 601 P 04C 109 611C 04E 109 611AC 04E 109 611AJ	<b>331163</b> <b>331164</b>
[50]	Ø 5 mm					<b>MK-5H</b>

## 26 74,5

<b>CHZJ</b>	07.2017 →	B (A) 3	999 cm <sup>3</sup> 4V	85 kW	(115 PS)	76,40 mm
<b>DGEA Euro 6</b>	05.2014 →	B (LA) 4	1395 cm <sup>3</sup> 4V	110 kW	(150 PS)	80,00 mm
<b>DJKA Euro 6</b>	05.2015 →	B (LA) 4	1395 cm <sup>3</sup> 4V	110 kW	(150 PS)	80,00 mm
<b>DKJA Euro 6</b>	09.2017 →	B (LA) 3	999 cm <sup>3</sup> 4V	85 kW	(115 PS) 10,5	76,40 mm
<b>DKLA</b>	06.2017 →	B (A) 3	999 cm <sup>3</sup> 4V	70 kW	(95 PS)	76,40 mm
<b>DKLB Euro 6</b>	01.2017 →	B (LA) 3	999 cm <sup>3</sup> 4V	63 kW	(86 PS)	76,40 mm
<b>DKRF Euro 6</b>	05.2015 →	B (LA) 3	999 cm <sup>3</sup> 4V	85 kW	(115 PS)	76,40 mm
IN [2] EX [2]	28,5 x 5 x 110,2 25,0 x 5 x 110,1	S - - RA/S- Ni -	- 45° - - - 30° - VS -	22 - III 22 - III	04E 109 601B 04C 109 611C 04E 109 611AC 04E 109 611AJ	<b>331158</b> <b>331164</b>
[50]	Ø 5 mm					<b>MK-5H</b>

## 27 74,5

<b>CHZD</b>	05.2015 →	B (LA) 3	999 cm <sup>3</sup> 4V	85 kW	(115 PS) 10,5	76,40 mm
IN [2] EX [2]	28,5 x 5 x 110,2 25,0 x 5 x 110,1	S - - RA/S- Ni -	- 45° - - - 30° - VS -	22 - III 22 - III	04E 109 601B 04C 109 611C 04E 109 611AC 04E 109 611AJ	<b>331158</b> <b>331164</b>
[50]	Ø 5 mm					<b>MK-5H</b>

Fortsetzung nächste Seite / continued on next page / suite page suivante / continuación página próxima / Продолжение на следующей странице

					Reference	Item No.	
	IN [1] EX [1]	10,06 x 5 x 45,0 10,05 x 5 x 45,0	B1 G2			<b>81-33123</b> <small>NEW</small> <b>81-33124</b> <small>NEW</small>	
<b>28</b>		<b>74,51</b>					
<b>CPGA Euro 5</b>	11.2012 → 08.2020	BG (NA)	3	999 cm <sup>3</sup> 4V	50 kW (68 PS)	11,5:1 76,40 mm	
	IN [2] EX [2]	29,6 x 5 x 110,2 27,0 x 5 x 110,1	S - - A/S - Cr -	- 45° - - - 30° - VS -	22 - III 22 - III	04C 109 601C 04E 109 601 04C 109 611A 04E 109 611L	<b>398000</b> <small>NEW</small> <b>398001</b> <small>NEW</small>
	[50]	∅ 5 mm					<b>MK-5H</b>
	IN [1] EX [1]	10,06 x 5 x 45,0 10,05 x 5 x 45,0	B1 G2			<b>81-33123</b> <small>NEW</small> <b>81-33124</b> <small>NEW</small>	
	[8]	H 12			04E109423C	<b>50 007 667</b>	
	[4]				04E109411AA 04E109411J	<b>50 007 668</b>	
<b>29</b>		<b>75</b>					
<b>2G</b>	01.1967 →	B (NA)	4	1272 cm <sup>3</sup> 2V	40 kW (54 PS)	9 72,00 mm	
<b>3F</b>	10.1989 → 09.1994	B (NA)	4	1272 cm <sup>3</sup> 2V	55-57 kW (75-78 PS)	10 72,00 mm	
<b>ACM</b>	02.1992 → 12.1992	B (NA)	4	1043 cm <sup>3</sup> 2V	33 kW (45 PS)	10 59,00 mm	
<b>NZ</b>		B (NA)	4	1272 cm <sup>3</sup> 2V	40 kW (55 PS)	9,2 72,00 mm	
93 896 6..							
	IN [2]	36,0 x 8 x 98,8	A/S - -	- 45° - -	22 - III	030 109 601 B 030 109 601 C 030 109 601 D 030 109 601 F 073 109 601 D	<b>33046</b>
	[50]	∅ 8 mm				113 109 651 A 400 501 068	<b>MK-8H</b>
	IN/EX [4] IN/EX [4] IN/EX [4] IN/EX [4]	11,08/15 x 7 x 36,5 12,06/15 x 8 x 36,5 12,13/15 x 8 x 36,5 12,20/15 x 8 x 36,5	B1 B1 B1 B1			030 103 419 A 056 103 419 A	<b>81-33107</b> <b>81-3310</b> <b>81-3312</b> <b>81-3311</b>
	[8]	H 35 x 26 x 26				034 109 309 034 109 309 AC 034 109 309 AD 034 109 309 N 074 109 309	<b>50 006 460</b>
<b>30</b>		<b>75</b>					
<b>EP</b>	08.1980 → 07.1986	B (NA)	4	1297 cm <sup>3</sup> 2V	44 kW (60 PS)	9 73,40 mm	
<b>ZA</b>	05.1973 → 01.1978	B (NA)	4	1297 cm <sup>3</sup> 2V	40 kW (55 PS)	8,5 73,40 mm	
<b>ZF</b>	05.1973 → 01.1978	B (NA)	4	1297 cm <sup>3</sup> 2V	44 kW (60 PS)	8,5 73,40 mm	
	EX [2]	31,0 x 8 x 98,5	A/S - Cr -	- 45° - VS -	22 - III	049 109 611 F	<b>33025</b>
	[50]	∅ 8 mm				113 109 651 A 400 501 068	<b>MK-8H</b>
	IN/EX [4] IN/EX [4] IN/EX [4] IN/EX [4] IN/EX [4]	12,06/15 x 8 x 36,5 12,07/15.2 x 8 x 42,5 12,13/15 x 8 x 36,5 12,20/15 x 8 x 36,5 12,20/15.2 x 8 x 42,5	B1 B1 B1 B1 B1			056 103 419 A 049 103 419	<b>81-3310</b> <b>81-3319</b> <b>81-3312</b> <b>81-3311</b> <b>81-3320</b>
Fortsetzung nächste Seite / continued on next page / suite page suivante / continuación página próxima / Продолжение на следующей странице							

					Reference	Item No.
[8]	M 35 x 28,5				056 109 311 A	50 007 621
<b>31</b>	<b>75</b>					
<b>FY</b>	01.1978 → 07.1983	B (NA)	4	1272 cm <sup>3</sup>	2V 40 kW (55 PS)	8,2 72,00 mm
<b>FZ</b>	01.1978 → 07.1983	B (NA)	4	1272 cm <sup>3</sup>	2V 44 kW (60 PS)	8,2 72,00 mm
<b>HH</b>	12.1976 → 07.1983	B (NA)	4	1272 cm <sup>3</sup>	2V 44 kW (60 PS)	8,2 72,00 mm
<b>HJ</b>	02.1977 → 07.1988	B (NA)	4	1272 cm <sup>3</sup>	2V 43 kW (58 PS)	8,2 72,00 mm
	IN/EX [4] 12,06/15 x 8 x 36,5	B1			056 103 419 A	<b>81-3310</b>
	IN/EX [4] 12,13/15 x 8 x 36,5	B1				<b>81-3312</b>
	IN/EX [4] 12,20/15 x 8 x 36,5	B1				<b>81-3311</b>
<b>32</b>	<b>75</b>					
<b>GF</b>	02.1977 → 1985	B (NA)	4	1272 cm <sup>3</sup>	2V 44 kW (60 PS)	8,2 72,00 mm
	EX [2] 28,2 x 8 x 110,5	A/S - -	-	- 45° - -	22 - III	036 109 611 <b>331104</b>
	[50] Ø 8 mm				113 109 651 A	<b>MK-8H</b>
	[50] Ø 8 mm				400 501 068	
	[50] Ø 8 mm				056 109 651	<b>RK-8</b>
	IN/EX [4] 12,06/15 x 8 x 36,5	B1			056 103 419 A	<b>81-3310</b>
	IN/EX [4] 12,07/15.2 x 8 x 42,5	B1			049 103 419	<b>81-3319</b>
	IN/EX [4] 12,13/15 x 8 x 36,5	B1				<b>81-3312</b>
	IN/EX [4] 12,20/15 x 8 x 36,5	B1				<b>81-3311</b>
	IN/EX [4] 12,20/15.2 x 8 x 42,5	B1				<b>81-3320</b>
<b>33</b>	<b>75</b>					
<b>EU</b>	08.1980 → 07.1986	B (NA)	4	1297 cm <sup>3</sup>	2V 44 kW (60 PS)	8,2 73,40 mm
	EX [2] 31,0 x 8 x 98,5	A/S - Cr -	-	- 45° - VS -	22 - III	049 109 611 F <b>33025</b>
	[50] Ø 8 mm				113 109 651 A	<b>MK-8H</b>
	[50] Ø 8 mm				400 501 068	
	IN/EX [4] 12,06/15 x 8 x 36,5	B1			056 103 419 A	<b>81-3310</b>
	IN/EX [4] 12,07/15.2 x 8 x 42,5	B1			049 103 419	<b>81-3319</b>
	IN/EX [4] 12,13/15 x 8 x 36,5	B1				<b>81-3312</b>
	IN/EX [4] 12,20/15 x 8 x 36,5	B1				<b>81-3311</b>
	IN/EX [4] 12,20/15.2 x 8 x 42,5	B1				<b>81-3320</b>
<b>34</b>	<b>75</b>					
<b>GL</b>	10.1981 → 10.1986	B (NA)	4	1043 cm <sup>3</sup>	2V 29 kW (40 PS)	9,5 59,00 mm
	EX [2] 28,2 x 8 x 110,5	A/S - -	-	- 45° - -	22 - III	036 109 611 <b>331104</b>
	[50] Ø 8 mm				113 109 651 A	<b>MK-8H</b>
	[50] Ø 8 mm				400 501 068	
	IN/EX [4] 12,07/15.2 x 8 x 42,5	B1			049 103 419	<b>81-3319</b>
	IN/EX [4] 12,20/15.2 x 8 x 42,5	B1				<b>81-3320</b>
<b>35</b>	<b>75</b>					
<b>GK</b>	09.1982 → 09.1989	B (NA)	4	1272 cm <sup>3</sup>	2V 55 kW (75 PS)	10,7 72,00 mm
<b>HK</b>	08.1983 → 07.1990	B (NA)	4	1272 cm <sup>3</sup>	2V 40 kW (55 PS)	9,5 72,00 mm
93 896 6..						
	EX [2] 28,2 x 8 x 110,5	A/S - -	-	- 45° - -	22 - III	036 109 611 <b>331104</b>
Fortsetzung nächste Seite / continued on next page / suite page suivante / continuación página próxima / Продолжение на следующей странице						

V

					Reference	Item No.	
[50]	Ø 8 mm				113 109 651 A 400 501 068	<b>MK-8H</b>	
[50]	Ø 8 mm				056 109 651	<b>RK-8</b>	
IN/EX [4]	12,07/15.2 x 8 x 42,5	B1			049 103 419	<b>81-3319</b>	
IN/EX [4]	12,20/15.2 x 8 x 42,5	B1				<b>81-3320</b>	
<b>36</b>		<b>75</b>					
<b>GN</b>	11.1983 → 08.1985	B (NA)	4	1043 cm <sup>3</sup> 2V	33-37 kW (45-50 PS)	9,5:1 59,00 mm	
<b>HW</b>	08.1983 → 07.1985	B (NA)	4	1272 cm <sup>3</sup> 2V	37 kW (50 PS)	9,5 72,00 mm	
93 896 6..							
IN/EX [4]	12,07/15.2 x 8 x 42,5	B1			049 103 419	<b>81-3319</b>	
IN/EX [4]	12,20/15.2 x 8 x 42,5	B1				<b>81-3320</b>	
<b>37</b>		<b>75</b>					
<b>HZ</b>		B (NA)	4	1043 cm <sup>3</sup> 2V	33-37 kW (45-50 PS)	9,5 59,00 mm	
<b>MH</b>	08.1983 → 07.1990	B (NA)	4	1272 cm <sup>3</sup> 2V	40 kW (55 PS)	9,2 72,00 mm	
<b>NU</b>	08.1985 → 12.1987	B (NA)	4	1272 cm <sup>3</sup> 2V	37 kW (50 PS)	9,2 72,00 mm	
93 896 6..							
IN [2]	36,0 x 8 x 98,8	A/S - -	-	- 45° - -	22 - III	030 109 601 B 030 109 601 C 030 109 601 D 030 109 601 F 073 109 601 D	<b>33046</b>
[50]	Ø 8 mm					113 109 651 A 400 501 068	<b>MK-8H</b>
IN/EX [4]	12,06/15 x 8 x 36,5	B1			056 103 419 A	<b>81-3310</b>	
IN/EX [4]	12,07/15.2 x 8 x 42,5	B1			049 103 419	<b>81-3319</b>	
IN/EX [4]	12,13/15 x 8 x 36,5	B1				<b>81-3312</b>	
IN/EX [4]	12,20/15 x 8 x 36,5	B1				<b>81-3311</b>	
IN/EX [4]	12,20/15.2 x 8 x 42,5	B1				<b>81-3320</b>	
[8]	H 35 x 26 x 26					034 109 309 034 109 309 AC 034 109 309 AD 034 109 309 N 074 109 309	<b>50 006 460</b>
<b>38</b>		<b>75</b>					
<b>AAK</b>	08.1989 → 07.1990	B (NA)	4	1043 cm <sup>3</sup> 2V	33 kW (45 PS)	9,5 59,00 mm	
<b>PY</b>	01.1987 → 09.1994	B (K)	4	1272 cm <sup>3</sup> 2V	83-85 kW (113-115 PS)	8 72,00 mm	
93 896 6..							
IN [2]	36,0 x 8 x 98,8	A/S - -	-	- 45° - -	22 - III	030 109 601 B 030 109 601 C 030 109 601 D 030 109 601 F 073 109 601 D	<b>33046</b>
[50]	Ø 8 mm					113 109 651 A 400 501 068	<b>MK-8H</b>
IN/EX [4]	12,06/15 x 8 x 36,5	B1			056 103 419 A	<b>81-3310</b>	
IN/EX [4]	12,13/15 x 8 x 36,5	B1				<b>81-3312</b>	
IN/EX [4]	12,20/15 x 8 x 36,5	B1				<b>81-3311</b>	
[8]	H 35 x 26 x 26					034 109 309 034 109 309 AC 034 109 309 AD 034 109 309 N 074 109 309	<b>50 006 460</b>
<b>39</b>		<b>75</b>					
<b>AAU</b>	08.1990 → 09.1994	B (NA)	4	1043 cm <sup>3</sup> 2V	33 kW (45 PS)	10 59,00 mm	
Fortsetzung nächste Seite / continued on next page / suite page suivante / continuación página próxima / Продолжение на следующей странице							

					Reference	Item No.
IN [2]	32,0 x 7 x 99,2	S - -	- 45° - VS -	22 - III	030 109 601N	<b>390058</b>
[50]	Ø 8 mm				113 109 651 A 400 501 068	<b>MK-8H</b>
IN/EX [4]	11,08/15 x 7 x 36,5	B1			030 103 419 A	<b>81-33107</b>
IN/EX [4]	12,06/15 x 8 x 36,5	B1			056 103 419 A	<b>81-3310</b>
IN/EX [4]	12,13/15 x 8 x 36,5	B1				<b>81-3312</b>
IN/EX [4]	12,20/15 x 8 x 36,5	B1				<b>81-3311</b>
[8]	H 35 x 26 x 26				034 109 309 034 109 309 AC 034 109 309 AD 034 109 309 N 074 109 309	<b>50 006 460</b>

**40** **75**  
**AAV** 01.1991 → 08.1994 B (NA) 4 1272 cm<sup>3</sup> 2V 40 kW (55 PS) 9,2 72,00 mm  
 93 896 6..

IN [2]	36,0 x 8 x 98,8	A/S - -	- 45° - -	22 - III	030 109 601 B 030 109 601 C 030 109 601 D 030 109 601 F 073 109 601 D	<b>33046</b>
[50]	Ø 7 mm				021 109 651	<b>MK-7H</b>
[50]	Ø 8 mm				113 109 651 A 400 501 068	<b>MK-8H</b>
IN/EX [4]	11,08/15 x 7 x 36,5	B1			030 103 419 A	<b>81-33107</b>
IN/EX [4]	12,06/15 x 8 x 36,5	B1			056 103 419 A	<b>81-3310</b>
IN/EX [4]	12,13/15 x 8 x 36,5	B1				<b>81-3312</b>
IN/EX [4]	12,20/15 x 8 x 36,5	B1				<b>81-3311</b>
[8]	H 35 x 26 x 26				034 109 309 034 109 309 AC 034 109 309 AD 034 109 309 N 074 109 309	<b>50 006 460</b>

**41** **75**  
**ABD** 08.1991 → 04.1999 B (NA) 4 1390 cm<sup>3</sup> 2V 40-44 kW (54-60 PS) 9,2 78,70 mm  
 92 228 6..

IN [2]	34,0 x 7 x 99,0	S - -	- 45° - -	22 - III	030 109 601 G	<b>39360</b>
IN [2]	36,0 x 8 x 98,8	A/S - -	- 45° - -	22 - III	030 109 601 B 030 109 601 C 030 109 601 D 030 109 601 F 073 109 601 D	<b>33046</b>
[50]	Ø 7 mm				021 109 651	<b>MK-7H</b>
[50]	Ø 8 mm				113 109 651 A 400 501 068	<b>MK-8H</b>
IN/EX [4]	11,08/15 x 7 x 36,5	B1			030 103 419 A	<b>81-33107</b>
IN/EX [4]	12,06/15 x 8 x 36,5	B1			056 103 419 A	<b>81-3310</b>
IN/EX [4]	12,13/15 x 8 x 36,5	B1				<b>81-3312</b>
IN/EX [4]	12,20/15 x 8 x 36,5	B1				<b>81-3311</b>
[8]	H 35 x 26 x 26				034 109 309 034 109 309 AC 034 109 309 AD 034 109 309 N 074 109 309	<b>50 006 460</b>

**V**

					Reference	Item No.		
<b>42</b>		<b>75</b>						
<b>AEV</b>	10.1994 → 12.1999	B	(NA)	4	1043 cm <sup>3</sup> 2V	33 kW (45 PS) 10	59,00 mm	
	IN [2]	32,0 x 7 x 99,2	S	- -	- 45° - VS -	22 - III	030 109 601N	<b>390058</b>
	[50]	∅ 7 mm					021 109 651	<b>MK-7H</b>
	IN/EX [4]	11,08/15 x 7 x 36,5	B1				030 103 419 A	<b>81-33107</b>
	[8]	H 35 x 26 x 26					034 109 309 034 109 309 AC 034 109 309 AD 034 109 309 N 074 109 309	<b>50 006 460</b>
<b>43</b>		<b>75</b>						
<b>MN</b>	08.1986 → 08.1990	D	(NA)	4	1272 cm <sup>3</sup> 2V	33 kW (44 PS) 22	72,00 mm	
	IN [2]	34,0 x 8 x 99,1	S	- -	- 45° - -	22 - III	030 109 601	<b>39262</b>
	[50]	∅ 8 mm					113 109 651 A 400 501 068	<b>MK-8H</b>
	IN/EX [4]	12,06/15 x 8 x 36,5	B1				056 103 419 A	<b>81-3310</b>
	IN/EX [4]	12,13/15 x 8 x 36,5	B1					<b>81-3312</b>
	IN/EX [4]	12,20/15 x 8 x 36,5	B1					<b>81-3311</b>
	[8]	H 35 x 26 x 26					034 109 309 034 109 309 AC 034 109 309 AD 034 109 309 N 074 109 309	<b>50 006 460</b>
<b>44</b>		<b>75</b>						
<b>1W</b>	08.1990 → 09.1994	D	(NA)	4	1398 cm <sup>3</sup> 2V	35 kW (48 PS) 22,5	79,10 mm	
	IN [2]	34,0 x 7 x 99,0	S	- -	- 45° - -	22 - III	030 109 601 G	<b>39360</b>
	IN [2]	34,0 x 8 x 99,1	S	- -	- 45° - -	22 - III	030 109 601	<b>39262</b>
	[50]	∅ 7 mm					021 109 651	<b>MK-7H</b>
	[50]	∅ 8 mm					113 109 651 A 400 501 068	<b>MK-8H</b>
	IN/EX [4]	11,08/15 x 7 x 36,5	B1				030 103 419 A	<b>81-33107</b>
	IN/EX [4]	12,06/15 x 8 x 36,5	B1				056 103 419 A	<b>81-3310</b>
	IN/EX [4]	12,13/15 x 8 x 36,5	B1					<b>81-3312</b>
	IN/EX [4]	12,20/15 x 8 x 36,5	B1					<b>81-3311</b>
	[8]	H 35 x 26 x 26					034 109 309 034 109 309 AC 034 109 309 AD 034 109 309 N 074 109 309	<b>50 006 460</b>
<b>45</b>		<b>76,5</b>						
<b>CDGA</b>	01.2009 → 05.2015	BG (A)		4	1390 cm <sup>3</sup> 4V	110 kW (150 PS)	75,60 mm	
	[50]	∅ 6 mm					036 109 651A	<b>MK-6H</b>

V



					Reference	Item No.	
<b>46</b>							
<b>FB</b>	02.1974 → 04.1974	B (NA)	4	1470 cm <sup>3</sup>	2V	48-55 kW (65-75 PS) 9,7:1	80,00 mm
<b>FD</b>	02.1974 → 12.1977	B (NA)	4	1471 cm <sup>3</sup>	2V	55-63 kW (75-86 PS) 9,7	80,00 mm
<b>FH</b>	02.1974 → 07.1980	B (NA)	4	1471 cm <sup>3</sup>	2V	51 kW (70 PS) 8,2	80,00 mm
<b>YJ</b>	08.1974 → 12.1975	B (NA)	4	1471 cm <sup>3</sup>	2V	55 kW (75 PS) 9,7	80,00 mm
<b>ZB</b>	07.1973 → 07.1974	B (NA)	4	1471 cm <sup>3</sup>	2V	55 kW (75 PS) 9,7	80,00 mm
<b>ZC</b>	05.1973 → 04.1982	B (NA)	4	1471 cm <sup>3</sup>	2V	57-63 kW (85 PS) 9,7	80,00 mm
	EX [2]	31,0 x 8 x 98,5	A/S - Cr -	- 45° - VS -	22 - III	049 109 611 F	<b>33025</b>
	[50]	∅ 8 mm				113 109 651 A 400 501 068	<b>MK-8H</b>
	IN/EX [4]	12,06/15 x 8 x 36,5	B1			056 103 419 A	<b>81-3310</b>
	IN/EX [4]	12,07/15.2 x 8 x 42,5	B1			049 103 419	<b>81-3319</b>
	IN/EX [4]	12,13/15 x 8 x 36,5	B1				<b>81-3312</b>
	IN/EX [4]	12,20/15 x 8 x 36,5	B1				<b>81-3311</b>
	IN/EX [4]	12,20/15.2 x 8 x 42,5	B1				<b>81-3320</b>
	[8]	M 35 x 28,5				056 109 311 A	<b>50 007 621</b>
<b>47</b>							
<b>DL</b>	08.1982 → 07.1992	B (NA)	6	2384 cm <sup>3</sup>	2V	66 kW (90 PS) 8,1	86,40 mm
	IN [2]	36,0 x 8 x 98,8	A/S - -	- 45° - -	22 - III	030 109 601 B 030 109 601 C 030 109 601 D 030 109 601 F 073 109 601 D	<b>33046</b>
	EX [2]	31,0 x 8 x 98,5	A/S - Cr -	- 45° - VS -	22 - III	049 109 611 F	<b>33025</b>
	[50]	∅ 8 mm				113 109 651 A 400 501 068	<b>MK-8H</b>
	IN/EX [4]	12,06/15 x 8 x 36,5	B1			056 103 419 A	<b>81-3310</b>
	IN/EX [4]	12,13/15 x 8 x 36,5	B1				<b>81-3312</b>
	IN/EX [4]	12,20/15 x 8 x 36,5	B1				<b>81-3311</b>
	[8]	M 35 x 28,5				056 109 311 A	<b>50 007 621</b>
<b>48</b>							
<b>1E</b>	08.1988 → 06.1996	B (NA)	6	2383 cm <sup>3</sup>	2V	69-70 kW (94-95 PS) 8,1	86,40 mm
	IN [2]	36,0 x 8 x 95,6	S - -	- 45° - -	22 - III	069 109 601 F	<b>39123</b>
	EX [2]	31,2 x 8 x 95,1	A/S - -	- 45° - VS -	22 - III	074 109 611	<b>33049</b>
	EX [2]	31,2 x 8 x 95,6	RA/S- Cr -	- 45° - VS -	22 - III	074 109 611	<b>39185</b>
	[50]	∅ 8 mm				113 109 651 A 400 501 068	<b>MK-8H</b>
	IN/EX [4]	12,06/15 x 8 x 36,5	B1			056 103 419 A	<b>81-3310</b>
	IN/EX [4]	12,13/15 x 8 x 36,5	B1				<b>81-3312</b>
	IN/EX [4]	12,20/15 x 8 x 36,5	B1				<b>81-3311</b>
	[8]	H 35 x 26 x 26				034 109 309 034 109 309 AC 034 109 309 AD 034 109 309 N 074 109 309	<b>50 006 460</b>

V

					Reference	Item No.			
<b>49</b>	<b>76,5</b>								
<b>AEX</b>		B (NA)	4	1390 cm <sup>3</sup>	2V	40-44 kW (54-60 PS)	10,2	75,60 mm	
<b>AKV</b>	07.1995 → 09.2001	B (NA)	4	1390 cm <sup>3</sup>	2V	44 kW (60 PS)	10,2	75,60 mm	
<b>ANX</b>	01.1998 → 09.2001	B (NA)	4	1390 cm <sup>3</sup>	2V	40 kW (54 PS)	10,2	75,60 mm	
<b>APQ</b>	07.1993 → 01.2004	B (NA)	4	1390 cm <sup>3</sup>	2V	44 kW (60 PS)	10,2	75,60 mm	
	IN [2] EX [2]	35,5 x 7 x 94,7 29,0 x 7 x 95,0	S - - RA/S- -	- 45° - - - 45° - VS -	22 - III 22 - III	030 109 601 AH 032 109 611 G		<b>39530</b> <b>39467</b>	
	[50]	∅ 7 mm				021 109 651		<b>MK-7H</b>	
	IN/EX [4] IN/EX [4]	11,08/15 x 7 x 33,0 11,28/15 x 7 x 33,0	B1 B1			032 103 419 A		<b>81-33109</b> <b>81-33110</b>	
						030 109 101 AM		<b>50 006 380</b> (1)	
								(1) Schalenhartguss/chilled cast iron/pièce moulée trempée en surface/fundición en coquilla/Отливка с отбелнным поверхностным слоем	
	[8]	H 35 x 26 x 26				050 109 309 050 109 309 A 050 109 309 H 050 109 309 J		<b>50 006 417</b>	
<b>50</b>	<b>76,5</b>								
<b>ABU</b>	09.1992 → 09.1994	B (NA)	4	1598 cm <sup>3</sup>	2V	55 kW (75 PS)	9,3	86,90 mm	
	IN [2] EX [2]	34,5 x 7 x 94,8 29,0 x 7 x 95,0	S - - RA/S- -	- 45° - VS - - 45° - VS -	22 - III 22 - III	032 109 601 G 032 109 611 G		<b>39367</b> <b>39467</b>	
	[50]	∅ 7 mm				021 109 651		<b>MK-7H</b>	
	IN/EX [4] IN/EX [4]	11,08/15 x 7 x 33,0 11,28/15 x 7 x 33,0	B1 B1			032 103 419 A		<b>81-33109</b> <b>81-33110</b>	
<b>51</b>	<b>76,5</b>								
<b>ADX</b>	10.1994 → 04.1997	B (NA)	4	1296 cm <sup>3</sup>	2V	40 kW (55 PS)	10	70,50 mm	
	EX [2]	29,0 x 7 x 95,0	RA/S- -	- 45° - VS -	22 - III	032 109 611 G		<b>39467</b>	
	[50]	∅ 7 mm				021 109 651		<b>MK-7H</b>	
	IN/EX [4] IN/EX [4]	11,08/15 x 7 x 33,0 11,28/15 x 7 x 33,0	B1 B1			032 103 419 A		<b>81-33109</b> <b>81-33110</b>	
	[8]	H 35 x 26 x 26				050 109 309 050 109 309 A 050 109 309 H 050 109 309 J		<b>50 006 417</b>	
<b>52</b>	<b>76,5</b>								
<b>AEA</b>	10.1994 → 10.1999	B (NA)	4	1598 cm <sup>3</sup>	2V	55 kW (75 PS)	9,8	86,90 mm	
<b>AHS</b>	03.1996 → 10.1999	B (NA)	4	1598 cm <sup>3</sup>	2V	55 kW (75 PS)	9,8	86,90 mm	
	IN [2] EX [2]	35,5 x 7 x 94,7 29,0 x 7 x 95,0	S - - RA/S- -	- 45° - - - 45° - VS -	22 - III 22 - III	030 109 601 AH 032 109 611 G		<b>39530</b> <b>39467</b>	
	[50]	∅ 7 mm				021 109 651		<b>MK-7H</b>	
Fortsetzung nächste Seite / continued on next page / suite page suivante / continuación página próxima / Продолжение на следующей странице									

					Reference	Item No.	
	IN/EX [4] 11,08/15 x 7 x 33,0 IN/EX [4] 11,28/15 x 7 x 33,0	B1 B1			032 103 419 A	<b>81-33109</b> <b>81-33110</b>	
	[8] H 35 x 26 x 26				050 109 309 050 109 309 A 050 109 309 H 050 109 309 J	<b>50 006 417</b>	
<b>53</b>	<b>76,5</b>						
<b>AEE</b>	07.1995 → 09.2001	B (NA)	4	1598 cm <sup>3</sup> 2V	55 kW (75 PS) 9,8	86,90 mm	
<b>ALM</b>	10.1999 → 09.2001	B (NA)	4	1598 cm <sup>3</sup> 2V	55 kW (75 PS) 9,8	86,90 mm	
	IN [2] 35,5 x 7 x 94,7 EX [2] 29,0 x 7 x 95,0	S - - RA/S- -		- 45° - - - 45° - VS -	22 - III 22 - III	030 109 601 AH 032 109 611 G	<b>39530</b> <b>39467</b>
	[50] Ø 7 mm				021 109 651	<b>MK-7H</b>	
	IN/EX [4] 11,08/15 x 7 x 33,0 IN/EX [4] 11,28/15 x 7 x 33,0	B1 B1			032 103 419 A	<b>81-33109</b> <b>81-33110</b>	
					032 109 101 S	<b>50 006 382</b> (1)	
	(1) Schalenhartguss/chilled cast iron/pièce moulée trempée en surface/fundición en coquilla/Отливка с отбеленным поверхностным слоем						
	[8] H 35 x 26 x 26				050 109 309 050 109 309 A 050 109 309 H 050 109 309 J	<b>50 006 417</b>	
<b>54</b>	<b>76,5</b>						
<b>AKK</b>	05.1997 → 09.2001	B (NA)	4	1390 cm <sup>3</sup> 2V	44 kW (60 PS) 10,4	75,60 mm	
<b>ANW</b>	10.1999 → 09.2001	B (NA)	4	1390 cm <sup>3</sup> 2V	44 kW (60 PS) 10,4	75,60 mm	
<b>AUD</b>	11.1995 → 07.2005	B (NA)	4	1390 cm <sup>3</sup> 2V	44 kW (60 PS) 10,4	75,60 mm	
94 773 6..							
	IN [2] 33,5 x 6 x 99,1 EX [2] 28,0 x 6 x 99,1	S - - A/S - -		- 45° - - - 45° - VS -	22 - III 22 - III	030109601AL 030109611T 032 109 611L 032 109 611M 03D 109 611A	<b>331046</b> <b>331047</b>
	IN/EX [4] 11,04 x 6 x 39,0 IN/EX [4] 11,05 x 6 x 36,0 IN/EX [4] 11,15 x 6 x 36,0 EX [4] 11,04 x 6 x 39,0	B1 B1 B1 G2			058 103 415	<b>81-33121</b> <b>81-33111</b> <b>81-33118</b> <b>81-33122</b>	
	[8] H 12 x 34,8 x 34,8				030 109 423 030 109 423 A 030 109 423 B 036 109 423 A 036 109 423 D CP40239	<b>50 006 415</b>	
	[4]				030 109 417 D	<b>50 006 141</b>	
<b>55</b>	<b>76,5</b>						
<b>AFH</b>	04.1996 → 10.1999	B (NA)	4	1390 cm <sup>3</sup> 4V	74 kW (100 PS) 10,5	75,60 mm	
99 562 6..							
	IN/EX [4] 11,04 x 6 x 39,0 IN/EX [4] 11,05 x 6 x 36,0 IN/EX [4] 11,15 x 6 x 36,0 EX [4] 11,04 x 6 x 39,0	B1 B1 B1 G2			058 103 415	<b>81-33121</b> <b>81-33111</b> <b>81-33118</b> <b>81-33122</b>	
Fortsetzung nächste Seite / continued on next page / suite page suivante / continuación página próxima / Продолжение на следующей странице							



					Reference	Item No.
[8]	H 31 x 26				036 109 309 D 036 109 309 F	<b>50 006 138</b>

## 56 76,5

AHW	10.1997 → 06.2006	B (NA)	4	1390 cm <sup>3</sup>	4V	55 kW	(75 PS)	10,5	75,60 mm
AKQ	10.1997 → 06.2006	B (NA)	4	1390 cm <sup>3</sup>	4V	55 kW	(75 PS)	10,5	75,60 mm
APE	10.1997 → 06.2006	B (NA)	4	1390 cm <sup>3</sup>	4V	55 kW	(75 PS)	10,5	75,60 mm
AUA	05.2000 → 05.2008	B (NA)	4	1390 cm <sup>3</sup>	4V	55 kW	(75 PS)	10,5	75,60 mm
BBY	10.2001 → 04.2012	B (NA)	4	1390 cm <sup>3</sup>	4V	55 kW	(75 PS)	10,5	75,60 mm

99 562 6..

IN [2]	29,5 x 6 x 100,9	S - -	- 45° - -	22 - III	036 109 601 AD 036 109 601 AK 036 109 601 AL 036 109 601 S 03C 109 601 J 03C 109 601 M	<b>39522</b>
EX [2]	26,0 x 6 x 100,6	RA/S- -	- 45° - VS -	22 - III	036 109 611 AE 036 109 611 K 03C 109 611 G 03C 109 611 R 03C 109 612	<b>39523</b>
[50]	Ø 6 mm				036 109 651A	<b>MK-6H</b>
IN/EX [4]	11,04 x 6 x 39,0	B1			058 103 415	<b>81-33121</b>
IN/EX [4]	11,05 x 6 x 36,0	B1				<b>81-33111</b>
IN/EX [4]	11,15 x 6 x 36,0	B1				<b>81-33118</b>
EX [4]	11,04 x 6 x 39,0	G2				<b>81-33122</b>
AS ES					036 109 101 AA 036 109 101 AC 036 109 101 DG	<b>50 006 155</b> (1) <b>50 006 156</b> (1)
(1) Schalenhartguss/chilled cast iron/pièce moulée trempée en surface/fundición en coquilla/Отливка с отбеленным поверхностным слоем						
[8]	H 12 x 34,8 x 34,8				030 109 423 030 109 423 A 030 109 423 B 036 109 423 A 036 109 423 D CP40239	<b>50 006 415</b>
[4]					036 109 411 036 109 411 C 036 109 411 D	<b>50 006 142</b>

## 57 76,5

ATN	02.2000 → 06.2006	B (NA)	4	1598 cm <sup>3</sup>	4V	77 kW	(105 PS)	11,5	86,90 mm
AUS	02.2000 → 06.2006	B (NA)	4	1598 cm <sup>3</sup>	4V	77 kW	(105 PS)	11,5	86,90 mm
AXP	10.1997 → 06.2006	B (NA)	4	1390 cm <sup>3</sup>	4V	55 kW	(75 PS)	10,5	75,60 mm
BCA	10.1997 → 09.2010	B (NA)	4	1390 cm <sup>3</sup>	4V	55 kW	(75 PS)	10,5	75,60 mm
BCB	02.2000 → 06.2006	B (NA)	4	1598 cm <sup>3</sup>	4V	77 kW	(105 PS)	11,5	86,90 mm
BKY	10.2001 → 04.2012	B (NA)	4	1390 cm <sup>3</sup>	4V	55 kW	(75 PS)	10,5	75,60 mm

99 562 6.., 99 563 6.., 99 913 6..

Fortsetzung nächste Seite / continued on next page / suite page suivante / continuación página próxima / Продолжение на следующей странице

					Reference	Item No.
IN [2]	29,5 x 6 x 100,9	S - -	- 45° - -	22 - III	036 109 601 AD 036 109 601 AK 036 109 601 AL 036 109 601 S 03C 109 601 J 03C 109 601 M	<b>39522</b>
EX [2]	26,0 x 6 x 100,6	RA/S- -	- 45° - VS -	22 - III	036 109 611 AE 036 109 611 K 03C 109 611 G 03C 109 611 R 03C 109 612	<b>39523</b>
[50]	∅ 6 mm				036 109 651A	<b>MK-6H</b>
IN/EX [4]	11,04 x 6 x 39,0	B1			058 103 415	<b>81-33121</b>
IN/EX [4]	11,05 x 6 x 36,0	B1				<b>81-33111</b>
IN/EX [4]	11,15 x 6 x 36,0	B1				<b>81-33118</b>
EX [4]	11,04 x 6 x 39,0	G2				<b>81-33122</b>
	AS				036 109 101 AA	<b>50 006 155</b> (1)
	(1) Schalenhartguss/chilled cast iron/pièce moulée trempée en surface/fundición en coquilla/Отливка с отбеленным поверхностным слоем					
[8]	H 12 x 34,8 x 34,8				030 109 423 030 109 423 A 030 109 423 B 036 109 423 A 036 109 423 D CP40239	<b>50 006 415</b>
[4]					036 109 411 036 109 411 C 036 109 411 D	<b>50 006 142</b>

## 58 76,5

<b>AFK</b>	08.1999 → 07.2005	B (NA)	4	1390 cm <sup>3</sup>	4V	74 kW	(101 PS)	10,5	75,60 mm
<b>AJV</b>	09.1998 → 10.1999	B (NA)	4	1598 cm <sup>3</sup>	4V	88 kW	(120 PS)	10,6	86,90 mm
<b>AQQ</b>	08.1999 → 07.2005	B (NA)	4	1390 cm <sup>3</sup>	4V	74 kW	(101 PS)	10,5	75,60 mm
<b>AUB</b>	08.1999 → 05.2008	B (NA)	4	1390 cm <sup>3</sup>	4V	74 kW	(101 PS)	10,5	75,60 mm
<b>BBZ</b>	10.2001 → 05.2008	B (NA)	4	1390 cm <sup>3</sup>	4V	74 kW	(101 PS)	10,5	75,60 mm

99 562 6..

IN [2]	29,5 x 6 x 100,9	S - -	- 45° - -	22 - III	036 109 601 AD 036 109 601 AK 036 109 601 AL 036 109 601 S 03C 109 601 J 03C 109 601 M	<b>39522</b>
EX [2]	26,0 x 6 x 100,6	RA/S- -	- 45° - VS -	22 - III	036 109 611 AE 036 109 611 K 03C 109 611 G 03C 109 611 R 03C 109 612	<b>39523</b>
[50]	∅ 6 mm				036 109 651A	<b>MK-6H</b>
IN/EX [4]	11,04 x 6 x 39,0	B1			058 103 415	<b>81-33121</b>
IN/EX [4]	11,05 x 6 x 36,0	B1				<b>81-33111</b>
IN/EX [4]	11,15 x 6 x 36,0	B1				<b>81-33118</b>
EX [4]	11,04 x 6 x 39,0	G2				<b>81-33122</b>
	ES AS				036 109 101DH 036 109 101AG	<b>50 007 636</b> <b>50 007 637</b>

Fortsetzung nächste Seite / continued on next page / suite page suivante / continuación página próxima / Продолжение на следующей странице

					Reference	Item No.	
[8]	H 12 x 34,8 x 34,8				030 109 423 030 109 423 A 030 109 423 B 036 109 423 A 036 109 423 D CP40239	50 006 415	
[4]					036 109 411 036 109 411 C 036 109 411 D	50 006 142	
<b>59</b>	<b>76,5</b>						
<b>AKP</b>	12.1998 → 09.2001	B (NA)	4	1390 cm <sup>3</sup> 2V	40 kW (54 PS)	10,2 75,60 mm	
IN [2] EX [2]	33,5 x 6 x 99,1 28,0 x 6 x 99,1	S - - A/S - -	- - - -	- 45° - - - 45° - VS -	22 - III 22 - III	030109601AL 030109611T 032 109 611L 032 109 611M 03D 109 611A	<b>331046</b> <b>331047</b>
IN/EX [4] IN/EX [4] IN/EX [4] EX [4]	11,04 x 6 x 39,0 11,05 x 6 x 36,0 11,15 x 6 x 36,0 11,04 x 6 x 39,0	B1 B1 B1 G2				058 103 415	<b>81-33121</b> <small>NEW</small> <b>81-33111</b> <b>81-33118</b> <small>NEW</small> <b>81-33122</b> <small>NEW</small>
[8]	H 12 x 34,8 x 34,8					030 109 423 030 109 423 A 030 109 423 B 036 109 423 A 036 109 423 D CP40239	50 006 415
<b>60</b>	<b>76,5</b>						
<b>ANM</b> 99 562 6..	08.1999 → 07.2005	B (NA)	4	1390 cm <sup>3</sup> 4V	74 kW (101 PS)	10,5:1 75,50 mm	
IN [2]  EX [2]	29,5 x 6 x 100,9  26,0 x 6 x 100,6	S - - RA/S- -	- - - -	- 45° - - - 45° - VS -	22 - III 22 - III	036 109 601 AD 036 109 601 AK 036 109 601 AL 036 109 601 S 03C 109 601 J 03C 109 601 M 036 109 611 AE 036 109 611 K 03C 109 611 G 03C 109 611 R 03C 109 612	<b>39522</b>  <b>39523</b>
[50]	∅ 6 mm					036 109 651A	<b>MK-6H</b>
IN/EX [4] IN/EX [4] IN/EX [4] EX [4]	11,04 x 6 x 39,0 11,05 x 6 x 36,0 11,15 x 6 x 36,0 11,04 x 6 x 39,0	B1 B1 B1 G2				058 103 415	<b>81-33121</b> <small>NEW</small> <b>81-33111</b> <b>81-33118</b> <small>NEW</small> <b>81-33122</b> <small>NEW</small>
	ES AS					036 109 101DH 036 109 101AG	<b>50 007 636</b> <b>50 007 637</b>
[8]	H 12 x 34,8 x 34,8					030 109 423 030 109 423 A 030 109 423 B 036 109 423 A 036 109 423 D CP40239	50 006 415

V



					Reference	Item No.	
<b>61</b>		<b>76,5</b>					
<b>ARC</b>		10.1999 → 09.2001	B (NA) 4	1598 cm <sup>3</sup> 4V	92 kW (125 PS)	11,5 86,90 mm	
<b>ARR</b>		02.2001 → 07.2005	B (NA) 4	1390 cm <sup>3</sup> 4V	77 kW (105 PS)	11,5 75,60 mm	
<b>AVY</b>		10.1999 → 07.2005	B (NA) 4	1598 cm <sup>3</sup> 4V	92 kW (125 PS)	11,5 86,90 mm	
<b>AXU</b>		02.2002 → 07.2006	B (NA) 4	1390 cm <sup>3</sup> 4V	63 kW (86 PS)	12 75,60 mm	
<b>BAD</b>		01.2002 → 06.2006	B (NA) 4	1598 cm <sup>3</sup> 4V	81 kW (110 PS)	12 86,90 mm	
	IN [2]	29,5 x 6 x 100,9	S - -	- 45° - -	22 - III	036 109 601 AD 036 109 601 AK 036 109 601 AL 036 109 601 S 03C 109 601 J 03C 109 601 M	<b>39522</b>
	EX [2]	26,0 x 6 x 100,6	RA/S- -	- 45° - VS -	22 - III	036 109 611 AE 036 109 611 K 03C 109 611 G 03C 109 611 R 03C 109 612	<b>39523</b>
	[50]	∅ 6 mm				036 109 651A	<b>MK-6H</b>
	IN/EX [4]	11,04 x 6 x 39,0	B1				<b>81-33121</b>
	IN/EX [4]	11,05 x 6 x 36,0	B1			058 103 415	<b>81-33111</b>
	IN/EX [4]	11,15 x 6 x 36,0	B1				<b>81-33118</b>
	EX [4]	11,04 x 6 x 39,0	G2				<b>81-33122</b>
	[8]	H 12 x 34,8 x 34,8				030 109 423 030 109 423 A 030 109 423 B 036 109 423 A 036 109 423 D CP40239	<b>50 006 415</b>
	[4]					036 109 411 036 109 411 C 036 109 411 D	<b>50 006 142</b>
<b>62</b>		<b>76,5</b>					
<b>AZD</b>		02.2000 → 06.2006	B (NA) 4	1598 cm <sup>3</sup> 4V	77 kW (105 PS)	11,5 86,90 mm	
99 563 6..							
	IN [2]	29,5 x 6 x 100,9	S - -	- 45° - -	22 - III	036 109 601 AD 036 109 601 AK 036 109 601 AL 036 109 601 S 03C 109 601 J 03C 109 601 M	<b>39522</b>
	EX [2]	26,0 x 6 x 100,6	RA/S- -	- 45° - VS -	22 - III	036 109 611 AE 036 109 611 K 03C 109 611 G 03C 109 611 R 03C 109 612	<b>39523</b>
	[50]	∅ 6 mm				036 109 651A	<b>MK-6H</b>
	IN/EX [4]	11,04 x 6 x 39,0	B1				<b>81-33121</b>
	IN/EX [4]	11,05 x 6 x 36,0	B1			058 103 415	<b>81-33111</b>
	IN/EX [4]	11,15 x 6 x 36,0	B1				<b>81-33118</b>
	EX [4]	11,04 x 6 x 39,0	G2				<b>81-33122</b>
		AS				036 109 101 AA	<b>50 006 155</b> (1)
		(1) Schalenhartguss/chilled cast iron/pièce moulée trempée en surface/fundición en coquilla/Отливка с отбеленным поверхностным слоем					
Fortsetzung nächste Seite / continued on next page / suite page suivante / continuación página próxima / Продолжение на следующей странице							

V

					Reference	Item No.
[8]	H 12 x 34,8 x 34,8				030 109 423 030 109 423 A 030 109 423 B 036 109 423 A 036 109 423 D CP40239	<b>50 006 415</b>
<b>63</b>	<b>76,5</b>					
<b>BAH</b>	02.2001 →	B (NA)	4	1598 cm <sup>3</sup> 2V	74-76 kW (101-103 PS)	10,5 86,90 mm
<b>BLM</b>	08.2002 → 12.2010	B (NA)	4	1390 cm <sup>3</sup> 2V	61 kW (83 PS)	75,60 mm
IN [2]	34,5 x 6 x 99,2	S - Cr -		- 45° - -	22 - III	032 109 601L 032 109 601M 03D 109 601B <b>331137</b>
EX [2]	28,0 x 6 x 99,1	A/S - -		- 45° - VS -	22 - III	030109611T 032 109 611L 032 109 611M 03D 109 611A <b>331047</b>
IN/EX [4]	11,04 x 6 x 39,0	B1				<b>81-33121</b> <small>NEW</small>
IN/EX [4]	11,05 x 6 x 36,0	B1			058 103 415	<b>81-33111</b>
IN/EX [4]	11,15 x 6 x 36,0	B1				<b>81-33118</b> <small>NEW</small>
EX [4]	11,04 x 6 x 39,0	G2				<b>81-33122</b> <small>NEW</small>
[4]					030 109 411 030 109 411B	<b>50 006 140</b>
<b>64</b>	<b>76,5</b>					
<b>AZQ</b>	10.2001 → 07.2007	B (NA)	3	1198 cm <sup>3</sup> 4V	47 kW (64 PS)	10,5 86,90 mm
<b>BME</b>	10.2001 → 07.2007	B (NA)	3	1198 cm <sup>3</sup> 4V	47 kW (64 PS)	10,5 86,90 mm
<b>BZG</b>	05.2007 → 11.2009	B (NA)	3	1198 cm <sup>3</sup> 4V	51 kW (69 PS)	10,5 86,90 mm
<b>CGPA</b>	03.2009 →	B (NA)	3	1198 cm <sup>3</sup> 4V	51 kW (70 PS)	10,5 86,90 mm
<b>CGPB</b>	03.2009 →	B (NA)	3	1198 cm <sup>3</sup> 4V	44 kW (60 PS)	10,5 86,90 mm
40 795 6..., 99 909 6..						
IN [2]	29,5 x 6 x 100,9	S - -		- 45° - -	22 - III	036 109 601 AD 036 109 601 AK 036 109 601 AL 036 109 601 S 03C 109 601 J 03C 109 601 M <b>39522</b>
EX [2]	26,0 x 6 x 100,6	RA/S- -		- 45° - VS -	22 - III	036 109 611 AE 036 109 611 K 03C 109 611 G 03C 109 611 R 03C 109 612 <b>39523</b>
[50]	∅ 6 mm					036 109 651A <b>MK-6H</b>
IN/EX [4]	11,04 x 6 x 39,0	B1				<b>81-33121</b> <small>NEW</small>
IN/EX [4]	11,05 x 6 x 36,0	B1			058 103 415	<b>81-33111</b>
IN/EX [4]	11,15 x 6 x 36,0	B1				<b>81-33118</b> <small>NEW</small>
EX [4]	11,04 x 6 x 39,0	G2				<b>81-33122</b> <small>NEW</small>
	ES AS				03E109101T 03E109101AA	<b>50 007 654</b> <b>50 007 655</b>
[8]	H 12 x 34,8 x 34,8				030 109 423 030 109 423 A 030 109 423 B 036 109 423 A 036 109 423 D CP40239	<b>50 006 415</b>
[4]					036 109 411 036 109 411 C 036 109 411 D	<b>50 006 142</b>

V

					Reference	Item No.	
<b>65</b>	<b>76,5</b>	<b>AWY</b> 01.2002 → 05.2007 B (NA) 3 1198 cm <sup>3</sup> 2V 40 kW (54 PS) 10,8 86,90 mm 99 452 6..					
	IN [2] EX [2]	34,5 x 6 x 99,2 28,0 x 6 x 99,1	S - Cr - A/S - -	- 45° - - - 45° - VS -	22 - III 22 - III	032 109 601L 032 109 601M 03D 109 601B 030109611T 032 109 611L 032 109 611M 03D 109 611A	<b>331137</b>          <b>331047</b>
	[50]	∅ 6 mm				036 109 651A	<b>MK-6H</b>
	IN/EX [4] IN/EX [4] IN/EX [4] IN/EX [4] EX [4]	11,04 x 6 x 39,0 11,05 x 6 x 36,0 11,15 x 6 x 36,0 12,06 x 5.99 x 36,4 11,04 x 6 x 39,0	B1 B1 B1 B1 G2			058 103 415	<b>81-33121</b> <b>81-33111</b> <b>81-33118</b> <b>81-33113</b> <b>81-33122</b>
	[8]	H 12 x 34,8 x 34,8				030 109 423 030 109 423 A 030 109 423 B 036 109 423 A 036 109 423 D CP40239	<b>50 006 415</b>
	[4]					030 109 417 D	<b>50 006 141</b>
<b>66</b>	<b>76,5</b>	<b>BBM</b> 05.2007 → 11.2009 B (NA) 3 1198 cm <sup>3</sup> 2V 44 kW (60 PS) 10,5 86,90 mm <b>BMD</b> 01.2002 → 07.2011 B (NA) 3 1198 cm <sup>3</sup> 2V 40 kW (54 PS) 10,3 86,90 mm <b>CHFA</b> 09.2010 → 12.2011 B (NA) 3 1198 cm <sup>3</sup> 2V 44 kW (60 PS) 10,5 86,90 mm <b>CHFB Euro 4</b> 06.2009 → 07.2011 B (NA) 3 1198 cm <sup>3</sup> 2V 40 kW (54 PS) 10,3 86,90 mm 99 452 6..					
	IN [2] EX [2]	34,5 x 6 x 99,2 28,0 x 6 x 99,1	S - Cr - A/S - -	- 45° - - - 45° - VS -	22 - III 22 - III	032 109 601L 032 109 601M 03D 109 601B 030109611T 032 109 611L 032 109 611M 03D 109 611A	<b>331137</b>          <b>331047</b>
	IN/EX [4] IN/EX [4] IN/EX [4] EX [4]	11,04 x 6 x 39,0 11,05 x 6 x 36,0 11,15 x 6 x 36,0 11,04 x 6 x 39,0	B1 B1 B1 G2			058 103 415	<b>81-33121</b> <b>81-33111</b> <b>81-33118</b> <b>81-33122</b>
	[8]	H 12 x 34,8 x 34,8				030 109 423 030 109 423 A 030 109 423 B 036 109 423 A 036 109 423 D CP40239	<b>50 006 415</b>
	[4]					030 109 417 D	<b>50 006 141</b>
<b>67</b>	<b>76,5</b>	<b>CFZA</b> 09.2002 → B (NA) 4 1598 cm <sup>3</sup> 2V 74-76 kW (101-103 PS) 10,5 86,90 mm					
Fortsetzung nächste Seite / continued on next page / suite page suivante / continuación página próxima / Продолжение на следующей странице							



					Reference	Item No.
IN [2]	34,5 x 6 x 99,2	S - Cr -	- 45° - -	22 - III	032 109 601L 032 109 601M 03D 109 601B	<b>331137</b>
EX [2]	28,0 x 6 x 99,1	A/S - -	- 45° - VS -	22 - III	030109611T 032 109 611L 032 109 611M 03D 109 611A	<b>331047</b>
[4]					030 109 411 030 109 411B	<b>50 006 140</b>

**68** **76,5**
**BAG** 02.2003 → 07.2008 B (NA) 4 1598 cm<sup>3</sup> 4V 85 kW (115 PS) 12 86,90 mm

IN [2]	29,5 x 6 x 100,9	S - -	- 45° - -	22 - III	036 109 601 AD 036 109 601 AK 036 109 601 AL 036 109 601 S 03C 109 601 J 03C 109 601 M	<b>39522</b>
EX [2]	26,0 x 6 x 100,6	RA/S- -	- 45° - VS -	22 - III	036 109 611 AE 036 109 611 K 03C 109 611 G 03C 109 611 R 03C 109 612	<b>39523</b>
[50]	∅ 6 mm				036 109 651A	<b>MK-6H</b>
IN/EX [4]	11,04 x 6 x 39,0	B1			058 103 415	<b>81-33121</b> <small>NEW</small>
IN/EX [4]	11,05 x 6 x 36,0	B1				<b>81-33111</b>
IN/EX [4]	11,15 x 6 x 36,0	B1				<b>81-33118</b> <small>NEW</small>
EX [4]	11,04 x 6 x 39,0	G2				<b>81-33122</b> <small>NEW</small>
[8]	H 12 x 34,8 x 34,8				030 109 423 030 109 423 A 030 109 423 B 036 109 423 A 036 109 423 D CP40239	<b>50 006 415</b>
[4]					036 109 411 036 109 411 C 036 109 411 D	<b>50 006 142</b>
[4]					036 109 411 E 036 109 411 H	<b>50 006 143</b>

**69** **76,5**
**BLF** 02.2003 → 10.2010 B (NA) 4 1598 cm<sup>3</sup> 4V 85 kW (115 PS) 12 86,90 mm

**BLP** 02.2003 → 07.2008 B (NA) 4 1598 cm<sup>3</sup> 4V 85 kW (115 PS) 12 86,90 mm

IN [2]	29,5 x 6 x 100,9	S - -	- 45° - -	22 - III	036 109 601 AD 036 109 601 AK 036 109 601 AL 036 109 601 S 03C 109 601 J 03C 109 601 M	<b>39522</b>
EX [2]	26,0 x 6 x 100,6	RA/S- -	- 45° - VS -	22 - III	036 109 611 AE 036 109 611 K 03C 109 611 G 03C 109 611 R 03C 109 612	<b>39523</b>
[50]	∅ 6 mm				036 109 651A	<b>MK-6H</b>

Fortsetzung nächste Seite / continued on next page / suite page suivante / continuación página próxima / Продолжение на следующей странице

					Reference	Item No.
	IN/EX [4] 11,04 x 6 x 39,0 IN/EX [4] 11,05 x 6 x 36,0 IN/EX [4] 11,15 x 6 x 36,0 EX [4] 11,04 x 6 x 39,0	B1 B1 B1 G2			058 103 415	<b>81-33121</b> <b>81-33111</b> <b>81-33118</b> <b>81-33122</b>
	ES AS  (1) Schalenhartguss/chilled cast iron/pièce moulée trempée en surface/fundición en coquilla/Отливка с отбелсным поверхностным слоем				03C 109 101 AT 03C 109 101 AF	<b>50 007 034</b> (1) <b>50 007 035</b> (1)
	[8] H 12 x 34,8 x 34,8				030 109 423 030 109 423 A 030 109 423 B 036 109 423 A 036 109 423 D CP40239	<b>50 006 415</b>
	[4]				036 109 411 E 036 109 411 H	<b>50 006 143</b>

**70** **76,5**  
**BKG** 10.2003 → 07.2006 B (NA) 4 1390 cm<sup>3</sup> 4V 66 kW (90 PS) 12 75,60 mm

	IN [2] 29,5 x 6 x 100,9  EX [2] 26,0 x 6 x 100,6	S - - RA/S- -	- 45° - -	22 - III	036 109 601 AD 036 109 601 AK 036 109 601 AL 036 109 601 S 03C 109 601 J 03C 109 601 M 036 109 611 AE 036 109 611 K 03C 109 611 G 03C 109 611 R 03C 109 612	<b>39522</b>  <b>39523</b>
	[50] Ø 6 mm				036 109 651A	<b>MK-6H</b>
	IN/EX [4] 11,04 x 6 x 39,0 IN/EX [4] 11,05 x 6 x 36,0 IN/EX [4] 11,15 x 6 x 36,0 EX [4] 11,04 x 6 x 39,0	B1 B1 B1 G2			058 103 415	<b>81-33121</b> <b>81-33111</b> <b>81-33118</b> <b>81-33122</b>
	ES AS  (1) Schalenhartguss/chilled cast iron/pièce moulée trempée en surface/fundición en coquilla/Отливка с отбелсным поверхностным слоем				03C 109 101 AC 03C 109 101 AD	<b>50 007 039</b> (1) <b>50 007 040</b> (1)
	[8] H 12 x 34,8 x 34,8				030 109 423 030 109 423 A 030 109 423 B 036 109 423 A 036 109 423 D CP40239	<b>50 006 415</b>
	[4]				036 109 411 036 109 411 C 036 109 411 D	<b>50 006 142</b>

**71** **76,5**  
**BLN** 10.2003 → 11.2006 B (NA) 4 1390 cm<sup>3</sup> 4V 66 kW (90 PS) 12 75,60 mm

Fortsetzung nächste Seite / continued on next page / suite page suivante / continuación página próxima / Продолжение на следующей странице						
--	--	--	--	--	--	--

					Reference	Item No.
IN [2]	29,5 x 6 x 100,9	S - -	- 45° - -	22 - III	036 109 601 AD 036 109 601 AK 036 109 601 AL 036 109 601 S 03C 109 601 J 03C 109 601 M	<b>39522</b>
EX [2]	26,0 x 6 x 100,6	RA/S- -	- 45° - VS -	22 - III	036 109 611 AE 036 109 611 K 03C 109 611 G 03C 109 611 R 03C 109 612	<b>39523</b>
[50]	Ø 6 mm				036 109 651A	<b>MK-6H</b>
IN/EX [4]	11,04 x 6 x 39,0	B1			058 103 415	<b>81-33121</b> <small>NEW</small>
IN/EX [4]	11,05 x 6 x 36,0	B1				<b>81-33111</b>
IN/EX [4]	11,15 x 6 x 36,0	B1				<b>81-33118</b> <small>NEW</small>
EX [4]	11,04 x 6 x 39,0	G2				<b>81-33122</b> <small>NEW</small>
	ES AS				03C 109 101 AS 03C 109 101 AH	<b>50 007 680</b> (1) <b>50 007 681</b> (1)
	(1) Schalenhartguss/chilled cast iron/pièce moulée trempée en surface/fundición en coquilla/Отливка с отбеленным поверхностным слоем					
[8]	H 12 x 34,8 x 34,8				030 109 423 030 109 423 A 030 109 423 B 036 109 423 A 036 109 423 D CP40239	<b>50 006 415</b>
[4]					036 109 411 E 036 109 411 H	<b>50 006 143</b>

**72**
**76,5**

<b>BLG</b>	11.2005 → 10.2010	B (A)	4	1390 cm <sup>3</sup>	4V	125 kW	(170 PS)	10	75,60 mm
<b>BMV</b>	02.2006 → 10.2010	B (A)	4	1390 cm <sup>3</sup>	4V	103 kW	(140 PS)	10	75,60 mm

40 846 6..

IN [2]	29,5 x 6 x 100,9	S - -	- 45° - -	22 - III	036 109 601 AD 036 109 601 AK 036 109 601 AL 036 109 601 S 03C 109 601 J 03C 109 601 M	<b>39522</b>
EX [2]	26,0 x 6 x 100,6	RA/S- -	- 45° - VS -	22 - III	036 109 611 AE 036 109 611 K 03C 109 611 G 03C 109 611 R 03C 109 612	<b>39523</b>
[50]	Ø 6 mm				036 109 651A	<b>MK-6H</b>
IN/EX [4]	11,04 x 6 x 39,0	B1			058 103 415	<b>81-33121</b> <small>NEW</small>
IN/EX [4]	11,05 x 6 x 36,0	B1				<b>81-33111</b>
IN/EX [4]	11,15 x 6 x 36,0	B1				<b>81-33118</b> <small>NEW</small>
EX [4]	11,04 x 6 x 39,0	G2				<b>81-33122</b> <small>NEW</small>
	ES				03C 109 101 DC	<b>50 007 018</b> <small>NEW</small> (1)
	(1) Schalenhartguss/chilled cast iron/pièce moulée trempée en surface/fundición en coquilla/Отливка с отбеленным поверхностным слоем					

Fortsetzung nächste Seite / continued on next page / suite page suivante / continuación página próxima / Продолжение на следующей странице



					Reference	Item No.
[8]	H 12 x 34,8 x 34,8				030 109 423 030 109 423 A 030 109 423 B 036 109 423 A 036 109 423 D CP40239	50 006 415
[4]					036 109 411 E 036 109 411 H	50 006 143

<b>73</b>		<b>76,5</b>							
CAVC	02.2006 → 05.2015	B (LA)	4	1390 cm <sup>3</sup>	4V	103 kW	(140 PS)	10	75,60 mm
CAVD	05.2008 →	B (A)	4	1390 cm <sup>3</sup>	4V	118 kW	(160 PS)	10:1	75,60 mm
40 846 6..									

IN [2]	29,5 x 6 x 100,9	S - -	- 45° - -	22 - III	036 109 601 AD 036 109 601 AK 036 109 601 AL 036 109 601 S 03C 109 601 J 03C 109 601 M	39522
EX [2]	26,0 x 6 x 100,6	RA/S- -	- 45° - VS -	22 - III	036 109 611 AE 036 109 611 K 03C 109 611 G 03C 109 611 R 03C 109 612	39523
[50]	Ø 6 mm				036 109 651A	MK-6H
IN/EX [4]	11,04 x 6 x 39,0	B1			058 103 415	81-33121
IN/EX [4]	11,05 x 6 x 36,0	B1				81-33111
IN/EX [4]	11,15 x 6 x 36,0	B1				81-33118
EX [4]	11,04 x 6 x 39,0	G2				81-33122
	ES AS				03C 109 101 DC 03C 109 101 DF	50 007 018  (1) 50 007 019  (1)
(1) Schalenhartguss/chilled cast iron/pièce moulée trempée en surface/fundición en coquilla/Отливка с отбеленным поверхностным слоем						
[4]					036 109 411 E 036 109 411 H	50 006 143

<b>74</b>		<b>76,5</b>							
BTS	05.2006 → 12.2010	B (NA)	4	1598 cm <sup>3</sup>	4V	77 kW	(105 PS)	10,5	86,90 mm
IN [2]	29,5 x 6 x 100,9	S - -	- 45° - -	22 - III	036 109 601 AD 036 109 601 AK 036 109 601 AL 036 109 601 S 03C 109 601 J 03C 109 601 M	39522			
EX [2]	26,0 x 6 x 100,6	RA/S- -	- 45° - VS -	22 - III	036 109 611 AE 036 109 611 K 03C 109 611 G 03C 109 611 R 03C 109 612	39523			
[50]	Ø 6 mm				036 109 651A	MK-6H			
IN/EX [4]	11,04 x 6 x 39,0	B1			058 103 415	81-33121			
IN/EX [4]	11,05 x 6 x 36,0	B1				81-33111			
IN/EX [4]	11,15 x 6 x 36,0	B1				81-33118			
EX [4]	11,04 x 6 x 39,0	G2				81-33122			

Fortsetzung nächste Seite / continued on next page / suite page suivante / continuación página próxima / Продолжение на следующей странице

					Reference	Item No.
	ES				03C109101DE	50 007 656
[8]	H 12 x 34,8 x 34,8				030 109 423 030 109 423 A 030 109 423 B 036 109 423 A 036 109 423 D CP40239	50 006 415
[4]					036 109 411 E 036 109 411 H	50 006 143

## 75 76,5

**BUD** 05.2006 → 12.2013 B (NA) 4 1390 cm<sup>3</sup> 4V 59-60 kW (80-82 PS) 10,5 75,60 mm  
40 839 6..

	IN [2]	29,5 x 6 x 100,9	S - -	- 45° - -	22 - III	036 109 601 AD 036 109 601 AK 036 109 601 AL 036 109 601 S 03C 109 601 J 03C 109 601 M	39522
	EX [2]	26,0 x 6 x 100,6	RA/S- -	- 45° - VS -	22 - III	036 109 611 AE 036 109 611 K 03C 109 611 G 03C 109 611 R 03C 109 612	39523
[50]		Ø 6 mm				036 109 651A	MK-6H
	IN/EX [4]	11,04 x 6 x 39,0	B1				81-33121
	IN/EX [4]	11,05 x 6 x 36,0	B1			058 103 415	81-33111
	IN/EX [4]	11,15 x 6 x 36,0	B1				81-33118
	EX [4]	11,04 x 6 x 39,0	G2				81-33122
	AS ES					036 109 101 AA 03C 109 101 CG 03C 109 101 EC	50 006 155 (1) 50 007 678 (1)
	AS					03C 109 101 ED	50 007 679 (1)
	(1) Schalenhartguss/chilled cast iron/pièce moulée trempée en surface/fundición en coquilla/Отливка с отбеленным поверхностным слоем						
[8]	H 12 x 34,8 x 34,8					030 109 423 030 109 423 A 030 109 423 B 036 109 423 A 036 109 423 D CP40239	50 006 415
[4]						036 109 411 036 109 411 C 036 109 411 D	50 006 142

## 76 76,5

**CGGA** 05.2006 → 12.2013 B (NA) 4 1390 cm<sup>3</sup> 4V 59 kW (80 PS) 10,5 75,60 mm  
**CGGB Euro 5** 03.2009 → 05.2014 B (NA) 4 1390 cm<sup>3</sup> 4V 63 kW (85 PS) 10,5:1 75,60 mm  
40 839 6..

Fortsetzung nächste Seite / continued on next page / suite page suivante / continuación página próxima / Продолжение на следующей странице

					Reference	Item No.
IN [2]	29,5 x 6 x 100,9	S - -	- 45° - -	22 - III	036 109 601 AD 036 109 601 AK 036 109 601 AL 036 109 601 S 03C 109 601 J 03C 109 601 M	<b>39522</b>
EX [2]	26,0 x 6 x 100,6	RA/S- -	- 45° - VS -	22 - III	036 109 611 AE 036 109 611 K 03C 109 611 G 03C 109 611 R 03C 109 612	<b>39523</b>
[50]	Ø 6 mm				036 109 651A	<b>MK-6H</b>
IN/EX [4]	11,04 x 6 x 39,0	B1			058 103 415	<b>81-33121</b>
IN/EX [4]	11,05 x 6 x 36,0	B1				<b>81-33111</b>
IN/EX [4]	11,15 x 6 x 36,0	B1				<b>81-33118</b>
EX [4]	11,04 x 6 x 39,0	G2				<b>81-33122</b>
	ES				03C 109 101 CG 03C 109 101 EC	<b>50 007 678</b> (1)
	AS				03C 109 101 ED	<b>50 007 679</b> (1)
	(1) Schalenhartguss/chilled cast iron/pièce moulée trempée en surface/fundición en coquilla/Отливка с отбеленным поверхностным слоем					
[8]	H 12 x 34,8 x 34,8				030 109 423 030 109 423 A 030 109 423 B 036 109 423 A 036 109 423 D CP40239	<b>50 006 415</b>
[4]					036 109 411 036 109 411 C 036 109 411 D	<b>50 006 142</b>

**77**
**76,5**
**CAVB**  
40 846 6..

11.2006 → 05.2015 B (LA) 4 1390 cm<sup>3</sup> 4V 125 kW (170 PS) 10 75,60 mm

IN [2]	29,5 x 6 x 100,9	S - -	- 45° - -	22 - III	036 109 601 AD 036 109 601 AK 036 109 601 AL 036 109 601 S 03C 109 601 J 03C 109 601 M	<b>39522</b>
EX [2]	26,0 x 6 x 100,6	RA/S- -	- 45° - VS -	22 - III	036 109 611 AE 036 109 611 K 03C 109 611 G 03C 109 611 R 03C 109 612	<b>39523</b>
[50]	Ø 6 mm				036 109 651A	<b>MK-6H</b>
IN/EX [4]	11,04 x 6 x 39,0	B1			058 103 415	<b>81-33121</b>
IN/EX [4]	11,05 x 6 x 36,0	B1				<b>81-33111</b>
IN/EX [4]	11,15 x 6 x 36,0	B1				<b>81-33118</b>
EX [4]	11,04 x 6 x 39,0	G2				<b>81-33122</b>
	AS				03C 109 101 DF 03C 109 101 DC	<b>50 007 019</b> (1)
	ES					<b>50 007 018</b> (1)
	(1) Schalenhartguss/chilled cast iron/pièce moulée trempée en surface/fundición en coquilla/Отливка с отбеленным поверхностным слоем					

Fortsetzung nächste Seite / continued on next page / suite page suivante / continuación página próxima / Продолжение на следующей странице

					Reference	Item No.
	[4]				036 109 411 E	<b>50 006 143</b>
	[1]				036 109 411 H	<b>50 007 650</b> (2)
	(2) Kipphebeleinheit - nicht voreingestellt! rocker shaft assembly - not preset! Unité culbuteur - n'est pas pré réglée! Unidad de balancines: no preajustada! Узел коромысла — без предварительной настройки!					

## 78 76,5

**CAXA Euro 5** 05.2007 → B (LA) 4 1390 cm<sup>3</sup> 4V 90 kW (122 PS) 10 75,60 mm  
40 477 6..

	IN [2]	29,5 x 6 x 100,9	S - -	- 45° - -	22 - III	036 109 601 AD 036 109 601 AK 036 109 601 AL 036 109 601 S 03C 109 601 J 03C 109 601 M	<b>39522</b>
	EX [2]	26,0 x 6 x 100,6	RA/S- -	- 45° - VS -	22 - III	036 109 611 AE 036 109 611 K 03C 109 611 G 03C 109 611 R 03C 109 612	<b>39523</b>
	[50]	∅ 6 mm				036 109 651A	<b>MK-6H</b>
	IN/EX [4]	11,04 x 6 x 39,0	B1			058 103 415	<b>81-33121</b> <small>NEW</small>
	IN/EX [4]	11,05 x 6 x 36,0	B1				<b>81-33111</b>
	IN/EX [4]	11,15 x 6 x 36,0	B1				<b>81-33118</b> <small>NEW</small>
	EX [4]	11,04 x 6 x 39,0	G2				<b>81-33122</b> <small>NEW</small>
		ES AS				03C 109 101 DC 03C 109 101 DD	<b>50 007 018</b> <small>NEW</small> (1) <b>50 007 056</b> <small>NEW</small> (1)
	(1) Schalenhartguss/chilled cast iron/pièce moulée trempée en surface/fundición en coquilla/Отливка с отбелнным поверхностным слоем						
	[8]	H 12 x 34,8 x 34,8				030 109 423 030 109 423 A 030 109 423 B 036 109 423 A 036 109 423 D CP40239	<b>50 006 415</b>
	[4]					036 109 411 E 036 109 411 H	<b>50 006 143</b>

## 79 76,5

**BWK** 09.2007 → 07.2018 B (LA) 4 1390 cm<sup>3</sup> 4V 110 kW (150 PS) 10:1 75,60 mm  
40 846 6..

	IN [2]	29,5 x 6 x 100,9	S - -	- 45° - -	22 - III	036 109 601 AD 036 109 601 AK 036 109 601 AL 036 109 601 S 03C 109 601 J 03C 109 601 M	<b>39522</b>
	EX [2]	26,0 x 6 x 100,6	RA/S- -	- 45° - VS -	22 - III	036 109 611 AE 036 109 611 K 03C 109 611 G 03C 109 611 R 03C 109 612	<b>39523</b>
	[50]	∅ 6 mm				036 109 651A	<b>MK-6H</b>

Fortsetzung nächste Seite / continued on next page / suite page suivante / continuación página próxima / Продолжение на следующей странице

					Reference	Item No.
	IN/EX [4] 11,04 x 6 x 39,0 IN/EX [4] 11,05 x 6 x 36,0 IN/EX [4] 11,15 x 6 x 36,0 EX [4] 11,04 x 6 x 39,0	B1 B1 B1 G2			058 103 415	<b>81-33121</b> <b>81-33111</b> <b>81-33118</b> <b>81-33122</b>
	[4]				036 109 411 E 036 109 411 H	<b>50 006 143</b>

## 80 76,5

CAVA	09.2007 →	B (A)	4	1390 cm <sup>3</sup>	4V	110 kW	(150 PS)	10:1	75,60 mm
CTHD	05.2008 →	B (A)	4	1390 cm <sup>3</sup>	4V	118 kW	(160 PS)	10	75,60 mm

40 846 6..

	IN [2]	29,5 x 6 x 100,9	S - -	- 45° - -	22 - III	036 109 601 AD 036 109 601 AK 036 109 601 AL 036 109 601 S 03C 109 601 J 03C 109 601 M	<b>39522</b>	
	EX [2]	26,0 x 6 x 100,6	RA/S- -	- 45° - VS -	22 - III	036 109 611 AE 036 109 611 K 03C 109 611 G 03C 109 611 R 03C 109 612	<b>39523</b>	
	[50]	∅ 6 mm				036 109 651A	<b>MK-6H</b>	
	IN/EX [4] IN/EX [4] IN/EX [4] EX [4]	11,04 x 6 x 39,0 11,05 x 6 x 36,0 11,15 x 6 x 36,0 11,04 x 6 x 39,0	B1 B1 B1 G2			058 103 415	<b>81-33121</b> <b>81-33111</b> <b>81-33118</b> <b>81-33122</b>	
		ES AS				03C 109 101 DC 03C 109 101 DF	<b>50 007 018</b> (1) <b>50 007 019</b> (1)	
		(1) Schalenhartguss/chilled cast iron/pièce moulée trempée en surface/fundición en coquilla/Отливка с отбеленным поверхностным слоем						
	[8]	H 12 x 34,8 x 34,8				030 109 423 030 109 423 A 030 109 423 B 036 109 423 A 036 109 423 D CP40239	<b>50 006 415</b>	
	[4]					036 109 411 E 036 109 411 H	<b>50 006 143</b>	

## 81 76,5

CNWA	05.2008 → 11.2017	B (A)	4	1390 cm <sup>3</sup>	4V	118 kW	(160 PS)		75,60 mm
CTHA	09.2007 →	B (A)	4	1390 cm <sup>3</sup>	4V	110 kW	(150 PS)	10,0:1	75,60 mm
CTKA	05.2008 → 11.2017	B (A)	4	1390 cm <sup>3</sup>	4V	118 kW	(160 PS)	10,0:1	75,60 mm

40 846 6..

	IN [2]	29,5 x 6 x 100,9	S - -	- 45° - -	22 - III	036 109 601 AD 036 109 601 AK 036 109 601 AL 036 109 601 S 03C 109 601 J 03C 109 601 M	<b>39522</b>
	EX [2]	26,0 x 6 x 100,6	RA/S- -	- 45° - VS -	22 - III	036 109 611 AE 036 109 611 K 03C 109 611 G 03C 109 611 R 03C 109 612	<b>39523</b>

Fortsetzung nächste Seite / continued on next page / suite page suivante / continuación página próxima / Продолжение на следующей странице

					Reference	Item No.
[50]	Ø 6 mm				036 109 651A	<b>MK-6H</b>
IN/EX [4] IN/EX [4] IN/EX [4] EX [4]	11,04 x 6 x 39,0 11,05 x 6 x 36,0 11,15 x 6 x 36,0 11,04 x 6 x 39,0	B1 B1 B1 G2			058 103 415	<b>81-33121</b> <b>81-33111</b> <b>81-33118</b> <b>81-33122</b>
	ES AS				03C 109 101 DC 03C 109 101 DF	<b>50 007 018</b> (1) <b>50 007 019</b> (1)
(1) Schalenhartguss/chilled cast iron/pièce moulée trempée en surface/fundición en coquilla/Отливка с отбелсным поверхностным слоем						

## 82 76,5

**CMSB Euro 4** 08.2008 → B (LA) 4 1390 cm<sup>3</sup> 4V 90 kW (122 PS) 10 75,60 mm  
40 477 6..

IN [2]	29,5 x 6 x 100,9	S - -	- 45° - -	22 - III	036 109 601 AD 036 109 601 AK 036 109 601 AL 036 109 601 S 03C 109 601 J 03C 109 601 M	<b>39522</b>
EX [2]	26,0 x 6 x 100,6	RA/S- -	- 45° - VS -	22 - III	036 109 611 AE 036 109 611 K 03C 109 611 G 03C 109 611 R 03C 109 612	<b>39523</b>
[50]	Ø 6 mm				036 109 651A	<b>MK-6H</b>
IN/EX [4] IN/EX [4] IN/EX [4] EX [4]	11,04 x 6 x 39,0 11,05 x 6 x 36,0 11,15 x 6 x 36,0 11,04 x 6 x 39,0	B1 B1 B1 G2			058 103 415	<b>81-33121</b> <b>81-33111</b> <b>81-33118</b> <b>81-33122</b>
	ES AS				03C 109 101 DC 03C 109 101 DD	<b>50 007 018</b> (1) <b>50 007 056</b> (1)
(1) Schalenhartguss/chilled cast iron/pièce moulée trempée en surface/fundición en coquilla/Отливка с отбелсным поверхностным слоем						

## 83 76,5

**CLPA Euro 5** 03.2009 → B (NA) 4 1390 cm<sup>3</sup> 4V 63 kW (85 PS) 10,5:1 75,60 mm  
**CNWB** 05.2010 → B (A) 4 1390 cm<sup>3</sup> 4V 110 kW (150 PS) 10 75,60 mm  
**CTHB** 05.2010 → 05.2015 B (LA) 4 1390 cm<sup>3</sup> 4V 125 kW (170 PS) 10 75,60 mm  
**CTHC** 05.2010 → 05.2015 B (LA) 4 1390 cm<sup>3</sup> 4V 103 kW (140 PS) 10 75,60 mm  
40 846 6..

IN [2]	29,5 x 6 x 100,9	S - -	- 45° - -	22 - III	036 109 601 AD 036 109 601 AK 036 109 601 AL 036 109 601 S 03C 109 601 J 03C 109 601 M	<b>39522</b>
EX [2]	26,0 x 6 x 100,6	RA/S- -	- 45° - VS -	22 - III	036 109 611 AE 036 109 611 K 03C 109 611 G 03C 109 611 R 03C 109 612	<b>39523</b>
[50]	Ø 6 mm				036 109 651A	<b>MK-6H</b>

Fortsetzung nächste Seite / continued on next page / suite page suivante / continuación página próxima / Продолжение на следующей странице



					Reference	Item No.
	IN/EX [4] 11,04 x 6 x 39,0 IN/EX [4] 11,05 x 6 x 36,0 IN/EX [4] 11,15 x 6 x 36,0 EX [4] 11,04 x 6 x 39,0	B1 B1 B1 G2			058 103 415	<b>81-33121</b> <b>81-33111</b> <b>81-33118</b> <b>81-33122</b>

## 84 76,5

<b>CFNA Euro 4</b>	01.2010 →	B (NA)	4	1598 cm <sup>3</sup>	4V	77 kW	(105 PS)	10,5	86,90 mm
<b>CLSA</b>	01.2010 →	B (NA)	4	1598 cm <sup>3</sup>	4V	77 kW	(105 PS)	10,5	86,90 mm

	IN [2] 29,5 x 6 x 100,9	S - -	- 45° - -	22 - III	036 109 601 AD 036 109 601 AK 036 109 601 AL 036 109 601 S 03C 109 601 J 03C 109 601 M	<b>39522</b>
	EX [2] 26,0 x 6 x 100,6	RA/S- -	- 45° - VS -	22 - III	036 109 611 AE 036 109 611 K 03C 109 611 G 03C 109 611 R 03C 109 612	<b>39523</b>
	[50] Ø 6 mm				036 109 651A	<b>MK-6H</b>
	IN/EX [4] 11,04 x 6 x 39,0 IN/EX [4] 11,05 x 6 x 36,0 IN/EX [4] 11,15 x 6 x 36,0 EX [4] 11,04 x 6 x 39,0	B1 B1 B1 G2			058 103 415	<b>81-33121</b> <b>81-33111</b> <b>81-33118</b> <b>81-33122</b>
	ES AS				03C 109 101 CP 03C 109 101 CQ	<b>50 007 025</b> (1) <b>50 007 026</b> (1)
	(1) Schalenhartguss/chilled cast iron/pièce moulée trempée en surface/fundición en coquilla/Отливка с отбелсным поверхностным слоем					
	[8] H 12 x 34,8 x 34,8				030 109 423 030 109 423 A 030 109 423 B 036 109 423 A 036 109 423 D CP40239	<b>50 006 415</b>

## 85 76,5

<b>CMAA</b>	03.2010 → 01.2011	B (NA)	4	1390 cm <sup>3</sup>	4V	60 kW	(82 PS)	75,60 mm
-------------	-------------------	--------	---	----------------------	----	-------	---------	----------

	[50] Ø 6 mm				036 109 651A	<b>MK-6H</b>
	AS ES				036 109 101 AA 03C 109 101 CG 03C 109 101 EC	<b>50 006 155</b> (1) <b>50 007 678</b> (1)
	(1) Schalenhartguss/chilled cast iron/pièce moulée trempée en surface/fundición en coquilla/Отливка с отбелсным поверхностным слоем					

## 86 76,5

<b>CAVE</b>	05.2010 →	B (A)	4	1390 cm <sup>3</sup>	4V	132 kW	(180 PS)	10	75,60 mm
-------------	-----------	-------	---	----------------------	----	--------	----------	----	----------

40 846 6..

Fortsetzung nächste Seite / continued on next page / suite page suivante / continuación página próxima / Продолжение на следующей странице

V

					Reference	Item No.
IN [2]	29,5 x 6 x 100,9	S - -	- 45° - -	22 - III	036 109 601 AD 036 109 601 AK 036 109 601 AL 036 109 601 S 03C 109 601 J 03C 109 601 M	<b>39522</b>
EX [2]	26,0 x 6 x 100,6	RA/S- -	- 45° - VS -	22 - III	036 109 611 AE 036 109 611 K 03C 109 611 G 03C 109 611 R 03C 109 612	<b>39523</b>
[50]	∅ 6 mm				036 109 651A	<b>MK-6H</b>
IN/EX [4]	11,04 x 6 x 39,0	B1			058 103 415	<b>81-33121</b> <small>NEW</small>
IN/EX [4]	11,05 x 6 x 36,0	B1				<b>81-33111</b>
IN/EX [4]	11,15 x 6 x 36,0	B1				<b>81-33118</b> <small>NEW</small>
EX [4]	11,04 x 6 x 39,0	G2				<b>81-33122</b> <small>NEW</small>
	ES AS				03C 109 101 DC 03C 109 101 DF	<b>50 007 018</b> <small>NEW</small> (1) <b>50 007 019</b> <small>NEW</small> (1)
(1) Schalenhartguss/chilled cast iron/pièce moulée trempée en surface/fundición en coquilla/Отливка с отбелсным поверхностным слоем						
[8]	H 12 x 34,8 x 34,8				030 109 423 030 109 423 A 030 109 423 B 036 109 423 A 036 109 423 D CP40239	<b>50 006 415</b>

## 87 76,5

CTHE  
40 846 6..

05.2010 →

B (A) 4

1390 cm<sup>3</sup> 4V

132 kW

(180 PS) 10

75,60 mm

IN [2]	29,5 x 6 x 100,9	S - -	- 45° - -	22 - III	036 109 601 AD 036 109 601 AK 036 109 601 AL 036 109 601 S 03C 109 601 J 03C 109 601 M	<b>39522</b>
EX [2]	26,0 x 6 x 100,6	RA/S- -	- 45° - VS -	22 - III	036 109 611 AE 036 109 611 K 03C 109 611 G 03C 109 611 R 03C 109 612	<b>39523</b>
[50]	∅ 6 mm				036 109 651A	<b>MK-6H</b>
IN/EX [4]	11,04 x 6 x 39,0	B1			058 103 415	<b>81-33121</b> <small>NEW</small>
IN/EX [4]	11,05 x 6 x 36,0	B1				<b>81-33111</b>
IN/EX [4]	11,15 x 6 x 36,0	B1				<b>81-33118</b> <small>NEW</small>
EX [4]	11,04 x 6 x 39,0	G2				<b>81-33122</b> <small>NEW</small>
	ES				03C 109 101 DC	<b>50 007 018</b> <small>NEW</small> (1)
(1) Schalenhartguss/chilled cast iron/pièce moulée trempée en surface/fundición en coquilla/Отливка с отбелсным поверхностным слоем						
[8]	H 12 x 34,8 x 34,8				030 109 423 030 109 423 A 030 109 423 B 036 109 423 A 036 109 423 D CP40239	<b>50 006 415</b>

					Reference	Item No.	
<b>88</b>		<b>76,5</b>					
<b>CFNB Euro 4</b>	11.2010 →	B (NA) 4	1598 cm <sup>3</sup> 4V	63 kW	(86 PS) 10,5	86,90 mm	
<b>CLRA Euro 4</b>	12.2011 →	B (NA) 4	1598 cm <sup>3</sup> 4V	77 kW	(105 PS) 10,5	86,90 mm	
	IN [2]	29,5 x 6 x 100,9	S - -	- 45° - -	22 - III	036 109 601 AD 036 109 601 AK 036 109 601 AL 036 109 601 S 03C 109 601 J 03C 109 601 M	<b>39522</b>
	EX [2]	26,0 x 6 x 100,6	RA/S- -	- 45° - VS -	22 - III	036 109 611 AE 036 109 611 K 03C 109 611 G 03C 109 611 R 03C 109 612	<b>39523</b>
	[50]	∅ 6 mm				036 109 651A	<b>MK-6H</b>
	IN/EX [4]	11,04 x 6 x 39,0	B1			058 103 415	<b>81-33121</b>
	IN/EX [4]	11,05 x 6 x 36,0	B1				<b>81-33111</b>
	IN/EX [4]	11,15 x 6 x 36,0	B1				<b>81-33118</b>
	EX [4]	11,04 x 6 x 39,0	G2				<b>81-33122</b>
	ES AS					03C 109 101 CP 03C 109 101 CQ	<b>50 007 025</b> (1) <b>50 007 026</b> (1)
	(1) Schalenhartguss/chilled cast iron/pièce moulée trempée en surface/fundición en coquilla/Отливка с отбеленным поверхностным слоем						
<b>89</b>		<b>76,5</b>					
<b>CNBA</b>	12.2010 →	B (NA) 4	1390 cm <sup>3</sup> 2V	61 kW	(83 PS)	75,60 mm	
	[8]	H 12				04E109423C	<b>50 007 667</b>
<b>90</b>		<b>76,5</b>					
<b>CNKA</b>	01.2011 → 05.2014	B (NA) 4	1598 cm <sup>3</sup> 4V	60 kW	(82 PS)	86,90 mm	
	[50]	∅ 6 mm				036 109 651A	<b>MK-6H</b>
<b>91</b>		<b>76,5</b>					
<b>CJLA</b>	08.2011 →	B (NA) 3	1198 cm <sup>3</sup> 4V	55 kW	(75 PS)	86,90 mm	
	IN [2]	29,5 x 6 x 100,9	S - -	- 45° - -	22 - III	036 109 601 AD 036 109 601 AK 036 109 601 AL 036 109 601 S 03C 109 601 J 03C 109 601 M	<b>39522</b>
	EX [2]	26,0 x 6 x 100,6	RA/S- -	- 45° - VS -	22 - III	036 109 611 AE 036 109 611 K 03C 109 611 G 03C 109 611 R 03C 109 612	<b>39523</b>
	[50]	∅ 6 mm				036 109 651A	<b>MK-6H</b>
	IN/EX [4]	11,04 x 6 x 39,0	B1			058 103 415	<b>81-33121</b>
	IN/EX [4]	11,05 x 6 x 36,0	B1				<b>81-33111</b>
	IN/EX [4]	11,15 x 6 x 36,0	B1				<b>81-33118</b>
	EX [4]	11,04 x 6 x 39,0	G2				<b>81-33122</b>
Fortsetzung nächste Seite / continued on next page / suite page suivante / continuación página próxima / Продолжение на следующей странице							

					Reference	Item No.				
	ES AS				03E109101T 03E109101AA	<b>50 007 654</b> <b>50 007 655</b>				
<b>92</b>	<b>76,5</b>									
<b>CWVA Euro 5</b>	05.2014 →	B (NA)	4	1598 cm <sup>3</sup>	4V	81 kW (110 PS)	10,5	86,90 mm		
<b>CWVB Euro 5</b>	07.2014 →	B (NA)	4	1598 cm <sup>3</sup>	4V	66 kW (90 PS)	10,5	86,90 mm		
41 487 6..										
	IN [2]	29,6 x 5 x 110,2	S - -	- 45° - -	22 - III	04C 109 601C 04E 109 601	<b>398000</b>			
	EX [2]	27,0 x 5 x 110,1	A/S - Cr -	- 30° - VS -	22 - III	04C 109 611A 04E 109 611L	<b>398001</b>			
	[50]	∅ 5 mm						<b>MK-5H</b>		
	IN [1]	10,06 x 5 x 45,0	B1						<b>81-33123</b>	
	EX [1]	10,05 x 5 x 45,0	G2						<b>81-33124</b>	
<b>93</b>	<b>76,5</b>									
<b>FK</b>		B (NA)	4	1471 cm <sup>3</sup>	2V	48-51 kW (65-70 PS)	8,2:1	80,00 mm		
	[8]	M 35 x 28,5						056 109 311 A	<b>50 007 621</b>	
<b>94</b>	<b>76,5</b>									
<b>HS</b>		B (NA)	6	2384 cm <sup>3</sup>	2V	62 kW (82 PS)	86,40 mm			
	IN [2]	36,0 x 8 x 98,8	A/S - -	- 45° - -	22 - III	030 109 601 B 030 109 601 C 030 109 601 D 030 109 601 F 073 109 601 D	<b>33046</b>			
	EX [2]	31,0 x 8 x 98,5	A/S - Cr -	- 45° - VS -	22 - III	049 109 611 F	<b>33025</b>			
	[50]	∅ 8 mm						113 109 651 A 400 501 068	<b>MK-8H</b>	
	IN/EX [4]	12,06/15 x 8 x 36,5	B1						056 103 419 A	<b>81-3310</b>
	IN/EX [4]	12,13/15 x 8 x 36,5	B1							<b>81-3312</b>
	IN/EX [4]	12,20/15 x 8 x 36,5	B1							<b>81-3311</b>
<b>95</b>	<b>76,5</b>									
<b>CCRA</b>	09.2002 →	AB (NA)	4	1598 cm <sup>3</sup>	2V	74-77 kW (101-105 PS)	10,5	86,90 mm		
	IN [2]	34,5 x 6 x 99,2	S - Cr -	- 45° - -	22 - III	032 109 601L 032 109 601M 03D 109 601B	<b>331137</b>			
	EX [2]	28,0 x 6 x 99,1	A/S - -	- 45° - VS -	22 - III	030109611T 032 109 611L 032 109 611M 03D 109 611A	<b>331047</b>			
	[4]							030 109 411 030 109 411B	<b>50 006 140</b>	
<b>96</b>	<b>76,5</b>									
<b>CKMA</b>	11.2010 → 12.2016	AB (A)	4	1390 cm <sup>3</sup>	4V	118 kW (160 PS)	10	75,60 mm		
	[50]	∅ 6 mm						036 109 651A	<b>MK-6H</b>	
	IN/EX [4]	11,04 x 6 x 39,0	B1						058 103 415	<b>81-33121</b>
	IN/EX [4]	11,05 x 6 x 36,0	B1							<b>81-33111</b>
	IN/EX [4]	11,15 x 6 x 36,0	B1							<b>81-33118</b>
	EX [4]	11,04 x 6 x 39,0	G2							<b>81-33122</b>

Fortsetzung nächste Seite / continued on next page / suite page suivante / continuación página próxima / Продолжение на следующей странице

					Reference	Item No.
	ES AS				03C 109 101 DC 03C 109 101 DF	<b>50 007 018</b> (1) <b>50 007 019</b> (1)
(1) Schalenhartguss/chilled cast iron/pièce moulée trempée en surface/fundición en coquilla/Отливка с отбеленным поверхностным слоем						

<b>97</b>		<b>76,5</b>				
<b>CUCA</b>			G (NA)	4	1598 cm <sup>3</sup> 4V	70 kW (95 PS) 0 86,90 mm
	[8]	H 12				04E109423C <b>50 007 667</b>

<b>98</b>		<b>76,5</b>				
<b>CK</b>	08.1976 → 12.1982	D (NA)	4	1471 cm <sup>3</sup> 2V	37 kW (50 PS) 23,5	80,00 mm
<b>CP</b>	01.1979 → 09.1983	D (NA)	6	2383 cm <sup>3</sup> 2V	55 kW (75 PS) 23,5	86,40 mm
93 085 6..., 93 260 6..						

	EX [2]	31,0 x 8 x 104,7	A/S - -	- 45° - -	22 - III		<b>331101</b>
	[50]	∅ 8 mm				113 109 651 A 400 501 068	<b>MK-8H</b>
	[50]	∅ 8 mm				056 109 651	<b>RK-8</b>
	IN/EX [4]	12,06/15 x 8 x 36,5	B1			056 103 419 A	<b>81-3310</b>
	IN/EX [4]	12,13/15 x 8 x 36,5	B1				<b>81-3312</b>
	IN/EX [4]	12,20/15 x 8 x 36,5	B1				<b>81-3311</b>
	[8]	M 35 x 28,5				056 109 311 A	<b>50 007 621</b>

<b>99</b>		<b>76,5</b>				
<b>682</b>	12.1977 → 01.1982	D (NA)	4	1471 cm <sup>3</sup> 2V	33 kW (45 PS) 23,5:1	80,00 mm
<b>685</b>		D (NA)	4	1588 cm <sup>3</sup> 2V	36 kW (49 PS) 23:1	86,40 mm
<b>686</b>	03.1989 → 12.1990	D (NA)	4	1588 cm <sup>3</sup> 2V	45 kW (61 PS) 23:1	86,40 mm
<b>68A</b>	04.1983 → 08.1988	D (A)	4	1588 cm <sup>3</sup> 2V	45 kW (61 PS) 23:1	86,40 mm
<b>68C</b>		D (A)	4	1588 cm <sup>3</sup> 2V	50 kW (68 PS) 23:1	86,40 mm
90 732 6..., 93 085 6..., 93 260 6..						

	IN [2]	34,0 x 8 x 104,9	RA/S- -	- 45° - -	22 - III	068 109 601 D	<b>4906</b>
	IN [2]	34,0 x 8 x 95,7	A/S - -	- 45° - -	22 - III	068 109 601 N	<b>331103</b>
	EX [2]	31,0 x 8 x 104,7	A/S - -	- 45° - -	22 - III		<b>331101</b>
	EX [2]	31,0 x 8 x 95,7	A/S - -	- 45° - -	22 - III	068 109 611 L	<b>331102</b>
	[50]	∅ 8 mm				113 109 651 A 400 501 068	<b>MK-8H</b>
	IN/EX [4]	12,06/15 x 8 x 36,5	B1			056 103 419 A	<b>81-3310</b>
	IN/EX [4]	12,13/15 x 8 x 36,5	B1				<b>81-3312</b>
	IN/EX [4]	12,20/15 x 8 x 36,5	B1				<b>81-3311</b>
		CAM - V - G - S - PC - SB - -		ready-to-install		068 103 351 D 068 103 351 E 068 103 351 G 068 103 351 K	<b>50 003 358</b> (1)
(1) Vorkammerbohrung/prechamber bore/alésage pour la préchambre/alojamiento de la precámara/ Отверстие форкамеры ∅ 32 mm / Mechanische Stößel/mechanical tappets/poussoirs mécaniques/ empujadores mecánicos/Механические толкатели							

<b>100</b>		<b>76,5</b>				
<b>DV</b>	08.1978 → 08.1992	D (A)	6	2384 cm <sup>3</sup> 2V	75-80 kW (102-109 PS) 23	86,40 mm
90 732 6..						

	IN [2]	36,0 x 8 x 104,9	A/S - -	- 45° - -	22 - III	069 109 601 D	<b>33044</b>
	IN [2]	36,0 x 8 x 95,6	RA/S- -	- 45° - VS -	22 - III	069 109 601 H	<b>39143</b>
	IN [2]	36,0 x 8 x 95,6	S - -	- 45° - -	22 - III	069 109 601 F	<b>39123</b>
	EX [2]	31,0 x 8 x 104,7	A/S - -	- 45° - -	22 - III		<b>331101</b>
	EX [2]	31,0 x 8 x 95,7	A/S - -	- 45° - -	22 - III	068 109 611 L	<b>331102</b>

Fortsetzung nächste Seite / continued on next page / suite page suivante / continuación página próxima / Продолжение на следующей странице

					Reference	Item No.
[50]	Ø 8 mm				113 109 651 A 400 501 068	<b>MK-8H</b>
IN/EX [4]	12,06/15 x 8 x 36,5	B1			056 103 419 A	<b>81-3310</b>
IN/EX [4]	12,07/15.2 x 8 x 42,5	B1			049 103 419	<b>81-3319</b>
IN/EX [4]	12,13/15 x 8 x 36,5	B1				<b>81-3312</b>
IN/EX [4]	12,20/15 x 8 x 36,5	B1				<b>81-3311</b>
IN/EX [4]	12,20/15.2 x 8 x 42,5	B1				<b>81-3320</b>
	(1) Schalenhartguss/chilled cast iron/pièce moulée trempée en surface/fundición en coquilla/Отливка с отбелнным поверхностным слоем				075 109 101 C 075 109 101 F	<b>50 006 218</b> (1)
[8]	H 35 x 26 x 26				034 109 309 034 109 309 AC 034 109 309 AD 034 109 309 N 074 109 309	<b>50 006 460</b>
[8]	M 35 x 28,5				056 109 311 A	<b>50 007 621</b>
<b>101</b>	<b>76,5</b>	<b>DW</b> 01.1979→07.1992 D (NA) 6 2383 cm <sup>3</sup> 2V 55-57 kW (75-78 PS) 23,5 86,40 mm 93 260 6..				
IN [2]	36,0 x 8 x 95,6	S - -	- 45° - -	22 - III	069 109 601 F	<b>39123</b>
EX [2]	31,0 x 8 x 104,7	A/S - -	- 45° - -	22 - III		<b>331101</b>
EX [2]	31,0 x 8 x 95,7	A/S - -	- 45° - -	22 - III	068 109 611 L	<b>331102</b>
[50]	Ø 8 mm				113 109 651 A 400 501 068	<b>MK-8H</b>
[50]	Ø 8 mm				056 109 651	<b>RK-8</b>
IN/EX [4]	12,06/15 x 8 x 36,5	B1			056 103 419 A	<b>81-3310</b>
IN/EX [4]	12,13/15 x 8 x 36,5	B1				<b>81-3312</b>
IN/EX [4]	12,20/15 x 8 x 36,5	B1				<b>81-3311</b>
	(1) Schalenhartguss/chilled cast iron/pièce moulée trempée en surface/fundición en coquilla/Отливка с отбелнным поверхностным слоем				075 109 101 C 075 109 101 F	<b>50 006 218</b> (1)
[8]	H 35 x 26 x 26				034 109 309 034 109 309 AC 034 109 309 AD 034 109 309 N 074 109 309	<b>50 006 460</b>
<b>102</b>	<b>76,5</b>	<b>CR</b> 02.1979→07.1992 D (NA) 4 1588 cm <sup>3</sup> 2V 39-40 kW (52-54 PS) 23,5 86,40 mm 93 260 6..				
IN [2]	34,0 x 8 x 95,6	S - -	- 45° - -	22 - III	068 109 601 L 068 109 601M	<b>39183</b>
EX [2]	31,0 x 8 x 104,7	A/S - -	- 45° - -	22 - III		<b>331101</b>
EX [2]	31,0 x 8 x 95,7	A/S - -	- 45° - -	22 - III	068 109 611 L	<b>331102</b>
[50]	Ø 8 mm				113 109 651 A 400 501 068	<b>MK-8H</b>
[50]	Ø 8 mm				056 109 651	<b>RK-8</b>
IN/EX [4]	12,06/15 x 8 x 36,5	B1			056 103 419 A	<b>81-3310</b>
IN/EX [4]	12,13/15 x 8 x 36,5	B1				<b>81-3312</b>
IN/EX [4]	12,20/15 x 8 x 36,5	B1				<b>81-3311</b>
[8]	M 35 x 28,5				056 109 311 A	<b>50 007 621</b>
Fortsetzung nächste Seite / continued on next page / suite page suivante / continuación página próxima / Продолжение на следующей странице						



					Reference	Item No.
	CAM - V - G - S - PC - SB - -		ready-to-install		068 103 351 D 068 103 351 E 068 103 351 G 068 103 351 K	<b>50 003 358</b> (1)
(1) Vorkammerbohrung/prechamber bore/alésage pour la préchambre/alojamiento de la precámara/ Отверстие форкамеры Ø 32 mm / Mechanische Stößel/mechanical tappets/poussoirs mécaniques/ empujadores mecánicos/Механические толкатели						
<b>103</b>		<b>76,5</b>				
<b>CS</b> 93 260 6..	01.1981 → 07.1987	D (NA)	4	1588 cm <sup>3</sup>	2V	37 kW (50 PS) 23,5 86,40 mm
	EX [2]	31,0 x 8 x 104,7	A/S - -	- 45° - -	22 - III	<b>331101</b>
	[50]	Ø 8 mm				113 109 651 A 400 501 068 <b>MK-8H</b>
	[50]	Ø 8 mm				056 109 651 <b>RK-8</b>
	IN/EX [4]	12,06/15 x 8 x 36,5	B1			056 103 419 A <b>81-3310</b>
	IN/EX [4]	12,13/15 x 8 x 36,5	B1			<b>81-3312</b>
	IN/EX [4]	12,20/15 x 8 x 36,5	B1			<b>81-3311</b>
	[8]	M 35 x 28,5				056 109 311 A <b>50 007 621</b>
	CAM - V - G - S - PC - SB - -		ready-to-install		068 103 351 D 068 103 351 E 068 103 351 G 068 103 351 K	<b>50 003 358</b> (1)
(1) Vorkammerbohrung/prechamber bore/alésage pour la préchambre/alojamiento de la precámara/ Отверстие форкамеры Ø 32 mm / Mechanische Stößel/mechanical tappets/poussoirs mécaniques/ empujadores mecánicos/Механические толкатели						
<b>104</b>		<b>76,5</b>				
<b>CY</b> 90 732 6..	08.1981 → 03.1988	D (A)	4	1588 cm <sup>3</sup>	2V	51 kW (70 PS) 23 86,40 mm
	IN [2]	34,0 x 8 x 104,9	RA/S- -	- 45° - -	22 - III	068 109 601 D <b>4906</b>
	IN [2]	34,0 x 8 x 95,7	A/S - -	- 45° - -	22 - III	068 109 601 N <b>331103</b>
	EX [2]	31,0 x 8 x 104,7	A/S - -	- 45° - -	22 - III	<b>331101</b>
	EX [2]	31,0 x 8 x 95,7	A/S - -	- 45° - -	22 - III	068 109 611 L <b>331102</b>
	[50]	Ø 8 mm				113 109 651 A 400 501 068 <b>MK-8H</b>
	IN/EX [4]	12,06/15 x 8 x 36,5	B1			056 103 419 A <b>81-3310</b>
	IN/EX [4]	12,13/15 x 8 x 36,5	B1			<b>81-3312</b>
	IN/EX [4]	12,20/15 x 8 x 36,5	B1			<b>81-3311</b>
						068 109 101 L <b>50 006 214</b> (1)
(1) Schalenhartguss/chilled cast iron/pièce moulée trempée en surface/fundición en coquilla/Отливка с отбелсным поверхностным слоем						
	[8]	H 35 x 26 x 26				034 109 309 034 109 309 AC 034 109 309 AD 034 109 309 N 074 109 309 <b>50 006 460</b>
	CAM - V - G - S - PC - SB - -		ready-to-install		068 103 351 D 068 103 351 E 068 103 351 G 068 103 351 K	<b>50 003 358</b> (2)
(2) Vorkammerbohrung/prechamber bore/alésage pour la préchambre/alojamiento de la precámara/ Отверстие форкамеры Ø 32 mm / Mechanische Stößel/mechanical tappets/poussoirs mécaniques/ empujadores mecánicos/Механические толкатели						

					Reference	Item No.
<b>105</b>	<b>76,5</b>	<b>JK</b> 08.1982 → 11.1998 D (NA) 4 1588 cm <sup>3</sup> 2V 39-40 kW (52-54 PS) 23,5 86,40 mm 93 260 6..				
	IN [2] 34,0 x 8 x 95,6	S - -	- 45° - -	22 - III	068 109 601 L 068 109 601M	<b>39183</b>
	IN [2] 34,0 x 8 x 95,7	A/S - -	- 45° - -	22 - III	068 109 601 N	<b>331103</b>
	EX [2] 31,0 x 8 x 104,7	A/S - -	- 45° - -	22 - III		<b>331101</b>
	EX [2] 31,0 x 8 x 95,7	A/S - -	- 45° - -	22 - III	068 109 611 L	<b>331102</b>
	[50] Ø 8 mm				113 109 651 A 400 501 068	<b>MK-8H</b>
	IN/EX [4] 12,06/15 x 8 x 36,5	B1			056 103 419 A	<b>81-3310</b>
	IN/EX [4] 12,13/15 x 8 x 36,5	B1				<b>81-3312</b>
	IN/EX [4] 12,20/15 x 8 x 36,5	B1				<b>81-3311</b>
					068 109 101 L	<b>50 006 214</b> (1)
	(1) Schalenhartguss/chilled cast iron/pièce moulée trempée en surface/fundición en coquilla/Отливка с отбелсным поверхностным слоем					
	[8] M 35 x 28,5				056 109 311 A 034 109 309 034 109 309 AC 034 109 309 AD 034 109 309 N 074 109 309	<b>50 007 621</b> <b>50 006 460</b>
	[8] H 35 x 26 x 26					
	CAM - V - G - S - PC - SB - -		ready-to-install		068 103 351 D 068 103 351 E 068 103 351 G 068 103 351 K	<b>50 003 358</b> (2)
	(2) Vorkammerbohrung/prechamber bore/alésage pour la préchambre/alojamiento de la precámara/Отверстие форкамеры Ø 32 mm / Mechanische Stößel/mechanical tappets/poussoirs mécaniques/empujadores mecánicos/Механические толкатели					
<b>106</b>	<b>76,5</b>	<b>ME</b> D (NA) 4 1588 cm <sup>3</sup> 2V 37-40 kW (50-55 PS) 23,5 86,40 mm <b>MF</b> D (A) 4 1588 cm <sup>3</sup> 2V 51 kW (70 PS) 23 86,40 mm <b>RA</b> D (LA) 4 1588 cm <sup>3</sup> 2V 59 kW (80 PS) 23 86,40 mm <b>SB</b> D (LA) 4 1588 cm <sup>3</sup> 2V 59 kW (80 PS) 23 86,40 mm 90 732 6.., 93 260 6..				
	IN [2] 34,0 x 8 x 95,6	S - -	- 45° - -	22 - III	068 109 601 L 068 109 601M	<b>39183</b>
	IN [2] 34,0 x 8 x 95,7	A/S - -	- 45° - -	22 - III	068 109 601 N	<b>331103</b>
	EX [2] 31,0 x 8 x 95,7	A/S - -	- 45° - -	22 - III	068 109 611 L	<b>331102</b>
	[50] Ø 8 mm				113 109 651 A 400 501 068	<b>MK-8H</b>
	IN/EX [4] 12,06/15 x 8 x 36,5	B1			056 103 419 A	<b>81-3310</b>
	IN/EX [4] 12,13/15 x 8 x 36,5	B1				<b>81-3312</b>
	IN/EX [4] 12,20/15 x 8 x 36,5	B1				<b>81-3311</b>
					068 109 101 L	<b>50 006 214</b> (1)
	(1) Schalenhartguss/chilled cast iron/pièce moulée trempée en surface/fundición en coquilla/Отливка с отбелсным поверхностным слоем					
	[8] H 35 x 26 x 26				034 109 309 034 109 309 AC 034 109 309 AD 034 109 309 N 074 109 309	<b>50 006 460</b>

V

					Reference	Item No.	
<b>107</b>		<b>76,5</b>					
<b>JP</b> 93 260 6..		D (NA) 4	1588 cm <sup>3</sup> 2V	40 kW	(54 PS) 23,5	86,40 mm	
	IN [2] IN [2] EX [2] EX [2]	34,0 x 8 x 95,6 34,0 x 8 x 95,7 31,0 x 8 x 104,7 31,0 x 8 x 95,7	S - - A/S - - A/S - - A/S - -	- 45° - - - 45° - - - 45° - - - 45° - -	22 - III 22 - III 22 - III 22 - III	068 109 601 L 068 109 601M 068 109 601 N 068 109 611 L	<b>39183</b> <b>331103</b> <b>331101</b> <b>331102</b>
	[50]	Ø 8 mm				113 109 651 A 400 501 068	<b>MK-8H</b>
	IN/EX [4] IN/EX [4] IN/EX [4]	12,06/15 x 8 x 36,5 12,13/15 x 8 x 36,5 12,20/15 x 8 x 36,5	B1 B1 B1			056 103 419 A	<b>81-3310</b> <b>81-3312</b> <b>81-3311</b>
						068 109 101 L	<b>50 006 214</b> (1)
	(1)	Schalenhartguss/chilled cast iron/pièce moulée trempée en surface/fundición en coquilla/Отливка с отбелсным поверхностным слоем					
	[8]	H 35 x 26 x 26				034 109 309 034 109 309 AC 034 109 309 AD 034 109 309 N 074 109 309	<b>50 006 460</b>
<b>108</b>		<b>76,5</b>					
<b>JR</b> 90 732 6..		D (A) 4	1588 cm <sup>3</sup> 2V	51 kW	(70 PS) 23	86,40 mm	
	IN [2] IN [2] EX [2] EX [2]	34,0 x 8 x 104,9 34,0 x 8 x 95,7 31,0 x 8 x 104,7 31,0 x 8 x 95,7	RA/S- - A/S - - A/S - - A/S - -	- 45° - - - 45° - - - 45° - - - 45° - -	22 - III 22 - III 22 - III 22 - III	068 109 601 D 068 109 601 N 068 109 611 L	<b>4906</b> <b>331103</b> <b>331101</b> <b>331102</b>
	[50]	Ø 8 mm				113 109 651 A 400 501 068	<b>MK-8H</b>
	IN/EX [4] IN/EX [4] IN/EX [4]	12,06/15 x 8 x 36,5 12,13/15 x 8 x 36,5 12,20/15 x 8 x 36,5	B1 B1 B1			056 103 419 A	<b>81-3310</b> <b>81-3312</b> <b>81-3311</b>
						068 109 101 L	<b>50 006 214</b> (1)
	(1)	Schalenhartguss/chilled cast iron/pièce moulée trempée en surface/fundición en coquilla/Отливка с отбелсным поверхностным слоем					
<b>109</b>		<b>76,5</b>					
<b>JX</b> 90 732 6.., 93 260 6..		08.1984 → 07.1992 D (A) 4	1588 cm <sup>3</sup> 2V	51 kW	(70 PS) 23,5	86,40 mm	
	IN [2] EX [2]	34,0 x 8 x 104,9 31,0 x 8 x 104,7	RA/S- - A/S - -	- 45° - - - 45° - -	22 - III 22 - III	068 109 601 D	<b>4906</b> <b>331101</b>
	[50]	Ø 8 mm				113 109 651 A 400 501 068	<b>MK-8H</b>
	IN/EX [4] IN/EX [4] IN/EX [4]	12,06/15 x 8 x 36,5 12,13/15 x 8 x 36,5 12,20/15 x 8 x 36,5	B1 B1 B1			056 103 419 A	<b>81-3310</b> <b>81-3312</b> <b>81-3311</b>
	[8]	M 35 x 28,5				056 109 311 A	<b>50 007 621</b>
Fortsetzung nächste Seite / continued on next page / suite page suivante / continuación página próxima / Продолжение на следующей странице							

V

					Reference	Item No.
	CAM - V - G - S - PC	- SB - -	ready-to-install		068 103 351 D 068 103 351 E 068 103 351 G 068 103 351 K	<b>50 003 358</b> (1)
(1) Vorkammerbohrung/prechamber bore/alésage pour la préchambre/alojamiento de la precámara/ Отверстие форкамеры Ø 32 mm / Mechanische Stößel/mechanical tappets/poussoirs mécaniques/ empujadores mecánicos/Механические толкатели						

**110**
**76,5**
**1C** 08.1987 → 12.1988 D (A) 4 1588 cm<sup>3</sup> 2V 51 kW (69 PS) 23 86,40 mm  
90 732 6..

	IN [2] EX [2]	34,0 x 8 x 104,9 31,0 x 8 x 104,7	RA/S- - A/S - -	- 45° - - - 45° - -	22 - III 22 - III	068 109 601 D	<b>4906</b> <b>331101</b>
	[50]	Ø 8 mm				113 109 651 A 400 501 068	<b>MK-8H</b>
	IN/EX [4] IN/EX [4] IN/EX [4]	12,06/15 x 8 x 36,5 12,13/15 x 8 x 36,5 12,20/15 x 8 x 36,5	B1 B1 B1			056 103 419 A	<b>81-3310</b> <b>81-3312</b> <b>81-3311</b>
	[8]	H 35 x 26 x 26				034 109 309 034 109 309 AC 034 109 309 AD 034 109 309 N 074 109 309	<b>50 006 460</b>

**111**
**76,5**
**1G** 08.1988 → 08.1992 D (A) 6 2384 cm<sup>3</sup> 2V 68 kW (93 PS) 23 86,40 mm  
90 732 6..

	IN [2] IN [2] EX [2] EX [2]	36,0 x 8 x 95,6 36,0 x 8 x 95,6 31,0 x 8 x 104,7 31,0 x 8 x 95,7	RA/S- - S - - A/S - - A/S - -	- 45° - VS - - 45° - - - 45° - - - 45° - -	22 - III 22 - III 22 - III 22 - III	069 109 601 H 069 109 601 F 068 109 611 L	<b>39143</b> <b>39123</b> <b>331101</b> <b>331102</b>
	[50]	Ø 8 mm				113 109 651 A 400 501 068	<b>MK-8H</b>
	IN/EX [4] IN/EX [4] IN/EX [4]	12,06/15 x 8 x 36,5 12,13/15 x 8 x 36,5 12,20/15 x 8 x 36,5	B1 B1 B1			056 103 419 A	<b>81-3310</b> <b>81-3312</b> <b>81-3311</b>
						075 109 101 C 075 109 101 F	<b>50 006 218</b> (1)
(1) Schalenhartguss/chilled cast iron/pièce moulée trempée en surface/fundición en coquilla/Отливка с отбелнным поверхностным слоем							
	[8]	H 35 x 26 x 26				034 109 309 034 109 309 AC 034 109 309 AD 034 109 309 N 074 109 309	<b>50 006 460</b>

**112**
**76,5**
**1S** 08.1988 → 12.1995 D (NA) 6 2383 cm<sup>3</sup> 2V 51 kW (70 PS) 23,5 86,40 mm  
**ACT** 08.1992 → 06.1996 D (NA) 6 2383 cm<sup>3</sup> 2V 51 kW (70 PS) 23 86,40 mm  
93 260 6..

	IN [2] EX [2]	36,0 x 8 x 95,6 31,0 x 8 x 95,7	S - - A/S - -	- 45° - - - 45° - -	22 - III 22 - III	069 109 601 F 068 109 611 L	<b>39123</b> <b>331102</b>
	[50]	Ø 8 mm				113 109 651 A 400 501 068	<b>MK-8H</b>

Fortsetzung nächste Seite / continued on next page / suite page suivante / continuación página próxima / Продолжение на следующей странице

					Reference	Item No.
	IN/EX [4] IN/EX [4] IN/EX [4]	12,06/15 x 8 x 36,5 12,13/15 x 8 x 36,5 12,20/15 x 8 x 36,5	B1 B1 B1		056 103 419 A	<b>81-3310</b> <b>81-3312</b> <b>81-3311</b>
					075 109 101 C 075 109 101 F	<b>50 006 218</b> (1)
	(1)	Schalenhartguss/chilled cast iron/pièce moulée trempée en surface/fundición en coquilla/Отливка с отбеленным поверхностным слоем				
	[8]	H 35 x 26 x 26			034 109 309 034 109 309 AC 034 109 309 AD 034 109 309 N 074 109 309	<b>50 006 460</b>

**113**
**76,5**
**68D** 03.1989 → 03.1994 D 4 1588 cm<sup>3</sup> 2V 36 kW (48 PS) 23:1 86,40 mm  
 93 260 6..

	IN [2] IN [2] EX [2] EX [2]	34,0 x 8 x 104,9 34,0 x 8 x 95,7 31,0 x 8 x 104,7 31,0 x 8 x 95,7	RA/S- - A/S - - A/S - - A/S - -	- 45° - - - 45° - - - 45° - - - 45° - -	22 - III 22 - III 22 - III 22 - III	068 109 601 D 068 109 601 N 068 109 611 L 068 109 611 L	<b>4906</b> <b>331103</b> <b>331101</b> <b>331102</b>
	[50]	Ø 8 mm				113 109 651 A 400 501 068	<b>MK-8H</b>
	IN/EX [4] IN/EX [4] IN/EX [4]	12,06/15 x 8 x 36,5 12,13/15 x 8 x 36,5 12,20/15 x 8 x 36,5	B1 B1 B1			056 103 419 A	<b>81-3310</b> <b>81-3312</b> <b>81-3311</b>
						068 109 101 L	<b>50 006 214</b> (1)
	(1)	Schalenhartguss/chilled cast iron/pièce moulée trempée en surface/fundición en coquilla/Отливка с отбеленным поверхностным слоем					
		CAM - V - G - S - PC - SB - -		ready-to-install		068 103 351 D 068 103 351 E 068 103 351 G 068 103 351 K	<b>50 003 358</b> (2)
	(2)	Vorkammerbohrung/prechamber bore/alésage pour la préchambre/alojamiento de la precámara/ Отверстие форкамеры Ø 32 mm / Mechanische Stößel/mechanical tappets/poussoirs mécaniques/ empujadores mecánicos/Механические толкатели					

**114**
**76,5**
**1V** D (A) 4 1589 cm<sup>3</sup> 2V 44 kW (60 PS) 23 86,40 mm  
 90 732 6..

	IN [2] EX [2]	34,0 x 8 x 95,7 31,0 x 8 x 95,7	A/S - - A/S - -	- 45° - - - 45° - -	22 - III 22 - III	068 109 601 N 068 109 611 L	<b>331103</b> <b>331102</b>
	[50]	Ø 8 mm				113 109 651 A 400 501 068	<b>MK-8H</b>
	IN/EX [4] IN/EX [4] IN/EX [4]	12,06/15 x 8 x 36,5 12,13/15 x 8 x 36,5 12,20/15 x 8 x 36,5	B1 B1 B1			056 103 419 A	<b>81-3310</b> <b>81-3312</b> <b>81-3311</b>
						068 109 101 L	<b>50 006 214</b> (1)
	(1)	Schalenhartguss/chilled cast iron/pièce moulée trempée en surface/fundición en coquilla/Отливка с отбеленным поверхностным слоем					

Fortsetzung nächste Seite / continued on next page / suite page suivante / continuación página próxima / Продолжение на следующей странице

					Reference	Item No.
[8]	H 35 x 26 x 26				034 109 309 034 109 309 AC 034 109 309 AD 034 109 309 N 074 109 309	<b>50 006 460</b>

## 115

76,5

ACL 06.1992 → 06.1996 D (A) 6 2384 cm<sup>3</sup> 2V 70 kW (95 PS) 22 86,40 mm  
90 732 6..

IN [2] EX [2]	36,0 x 8 x 95,6 31,0 x 8 x 95,7	RA/S- - A/S - -	- 45° - VS - - 45° - -	22 - III 22 - III	069 109 601 H 068 109 611 L	<b>39143</b> <b>331102</b>
[50]	∅ 8 mm				113 109 651 A 400 501 068	<b>MK-8H</b>
IN/EX [4] IN/EX [4] IN/EX [4]	12,06/15 x 8 x 36,5 12,13/15 x 8 x 36,5 12,20/15 x 8 x 36,5	B1 B1 B1			056 103 419 A	<b>81-3310</b> <b>81-3312</b> <b>81-3311</b>
					075 109 101 C 075 109 101 F	<b>50 006 218</b> (1)
(1) Schalenhartguss/chilled cast iron/pièce moulée trempée en surface/fundición en coquilla/Отливка с отбеленным поверхностным слоем						
[8]	H 35 x 26 x 26				034 109 309 034 109 309 AC 034 109 309 AD 034 109 309 N 074 109 309	<b>50 006 460</b>

## 116

76,5

ANY 07.1999 → 11.2000 D (LA) 3 1191 cm<sup>3</sup> 2V 45 kW (61 PS) 19,5 86,40 mm  
AYZ 11.2000 → 07.2005 D (A) 3 1191 cm<sup>3</sup> 2V 45 kW (61 PS) 19,5 86,40 mm

IN [2] EX [2]	36,0 x 7 x 89,6 31,5 x 7 x 89,6	S - - RA/S- -	- 45° - - - 45° - VS -	22 - III 22 - III	045 109 601 045 109 611	<b>331049</b> <b>331050</b>
[50]	∅ 7 mm				021 109 651	<b>MK-7H</b>
IN/EX [4] IN/EX [4]	12,08/15 x 7 x 36,5 12,25/15 x 7 x 36,5	B1 B1			037 103 415 037 103 419 B	<b>81-33103</b> <b>81-33104</b>
[8]	H 35 x 26 x 26				038 109 309 A 038 109 309 B 038 109 309 C	<b>50 006 418</b>

## 117

77

**113 (34)** 01.1960 → 12.1972 B 4 1192 cm<sup>3</sup> 2V 22-25 kW (30-34 PS) 7-7,3 64,00 mm  
91 350 7.., 92 412 6..

[50]	∅ 8 mm				113 109 651 A 400 501 068	<b>MK-8H</b>
IN [4] IN [4] IN [4] EX [4] EX [4]	12,04 x 8 x 64,5 12,07 x 8 x 64,5 12,24 x 8 x 64,5 12,04 x 8 x 65,5 12,07 x 8 x 65,5	B1 B1 B1 B1 B1			113 101 401 113 101 404 113 101 415	<b>81-3907</b> <b>81-3915</b> <b>81-3908</b> <b>81-3910</b> <b>81-3916</b>

## 118

77

AC 01.1965 → 07.1975 B (NA) 4 1285 cm<sup>3</sup> 2V 29 kW (39 PS) 7,3:1 69,00 mm

IN [2] EX [2]	35,5 x 8 x 111,7 30,0 x 9 x 111,9	S - - A/S - Cr -	- 45° - - - 45° - VS -	22 - III 22 - III	311 109 601 043 109 611	<b>33009</b> <b>33016</b>
------------------	--------------------------------------	---------------------	---------------------------	----------------------	----------------------------	------------------------------

Fortsetzung nächste Seite / continued on next page / suite page suivante / continuación página próxima / Продолжение на следующей странице



					Reference	Item No.	
[50]	∅ 8 mm				113 109 651 A 400 501 068	<b>MK-8H</b>	
[50]	∅ 9 mm					<b>MK-9H</b>	
IN [4] EX [4]	12,10 x 8 x 64,0 14,10 x 9 x 64,0	B1 G1			113 101 403 A 043 101 417 C	<b>81-3958</b> <b>81-3956</b>	
<b>119</b>							
<b>AR</b>	08.1966 → 07.1975	B (NA)	4	1285 cm <sup>3</sup> 2V	31-32 kW (42-44 PS)	7,5:1 69,00 mm	
IN [2] EX [2] EX [2]	35,5 x 8 x 111,7 30,0 x 9 x 111,9 32,0 x 8 x 111,9	S - - A/S - Cr - A/S - -		- 45° - - - 45° - VS - - 45° - VS -	22 - III 22 - III 22 - III	311 109 601 043 109 611 311 109 612 A	<b>33009</b> <b>33016</b> <b>33008</b>
[50]	∅ 8 mm				113 109 651 A 400 501 068	<b>MK-8H</b>	
[50]	∅ 9 mm					<b>MK-9H</b>	
IN [4] EX [4]	12,10 x 8 x 64,0 14,10 x 9 x 64,0	B1 G1			113 101 403 A 043 101 417 C	<b>81-3958</b> <b>81-3956</b>	
<b>120</b>							
<b>AB</b>	08.1966 → 12.1982	B (NA)	4	1285 cm <sup>3</sup> 2V	31-32 kW (44 PS)	7,5 69,00 mm	
92 614 6..							
IN [2] EX [2]	35,5 x 8 x 111,7 32,0 x 8 x 111,9	S - - A/S - -		- 45° - - - 45° - VS -	22 - III 22 - III	311 109 601 311 109 612 A	<b>33009</b> <b>33008</b>
[50]	∅ 8 mm				113 109 651 A 400 501 068	<b>MK-8H</b>	
IN [4] IN [4] IN [4] IN [4] EX [4] EX [4] EX [4]	12,04 x 8 x 64,5 12,07 x 8 x 64,5 12,10 x 8 x 64,0 12,24 x 8 x 64,5 12,04 x 8 x 65,5 12,07 x 8 x 65,5 14,10 x 9 x 64,0	B1 B1 B1 B1 B1 B1 G1			113 101 401 113 101 403 A 113 101 404 113 101 415 043 101 417 C	<b>81-3907</b> <b>81-3915</b> <b>81-3958</b> <b>81-3908</b> <b>81-3910</b> <b>81-3916</b> <b>81-3956</b>	
<b>121</b>							
<b>122</b>		B (NA)	4	1192 cm <sup>3</sup> 2V	18-25 kW (25-34 PS)	7,5:1 64,00 mm	
<b>122/2</b>	08.1972 → 07.1991	B	4	1192 cm <sup>3</sup> 2V	25 kW (34 PS)	7,5:1 64,00 mm	
91 350 7.., 92 412 6..							
IN/EX [4] IN/EX [4] IN/EX [4] EX [4]	11,04 x 6 x 39,0 11,05 x 6 x 36,0 11,15 x 6 x 36,0 11,04 x 6 x 39,0	B1 B1 B1 G2			058 103 415	<b>81-33121</b> <b>81-33111</b> <b>81-33118</b> <b>81-33122</b>	
<b>122</b>							
<b>AFB</b>	07.1998 → 05.2005	D (LA)	6	2496 cm <sup>3</sup> 4V	110 kW (150 PS)	19,5 86,40 mm	
99 776 6.., 99 777 6..							
IN [2] IN [2]	27,1 x 6 x 100,5 27,2 x 6 x 100,5	S - - S - -		- 45° - - - 45° - -	22 - III 22 - III	059 109 601 C 059 109 601 B 059 109 601 C	<b>33463</b> <b>331055</b>
EX [2]	24,2 x 6 x 100,5	A/S - -		- 45° - VS -	22 - III	059 109 611 B	<b>331056</b>
IN/EX [4]	10,06 x 6 x 42,0	B1				<b>81-33112</b>	
Fortsetzung nächste Seite / continued on next page / suite page suivante / continuación página próxima / Продолжение на следующей странице							

V

					Reference	Item No.
	ES				059 109 021 BP 059 109 021 K 059 109 021 Q	<b>50 006 300</b> (1)
	ES				059 109 021 BQ 059 109 021 L 059 109 021 P	<b>50 006 301</b> (2)
	AS				059 109 022 BD 059 109 022 L 059 109 022 P	<b>50 006 302</b> (2)
	AS				059 109 022 BC 059 109 022 K 059 109 022 Q	<b>50 006 303</b> (1)
	(1) für Zylinder/for cylinder/pour cylindre/para cilindro/для цилиндров 1-3 für Zylinder/for cylinder/pour cylindre/para cilindro/для цилиндров 1-3 / Schalenhartguss/chilled cast iron/pièce moulée trempée en surface/fundición en coquilla/Отливка с отбелсным поверхностным слоем  (2) Schalenhartguss/chilled cast iron/pièce moulée trempée en surface/fundición en coquilla/Отливка с отбелсным поверхностным слоем					
	[8]	H 12 x 35 x 35			059 109 521 B 059 109 521 C 059 109 521 E	<b>50 006 411</b>
	[12]				059 109 444	<b>50 006 410</b>

**123**
**78,3**
**AKN** 07.1998 → 05.2005 D (LA) 6 2496 cm<sup>3</sup> 4V 110 kW (150 PS) 19,5 86,40 mm  
 99 776 6..., 99 777 6..

	IN [2]	27,2 x 6 x 100,5	S - -	- 45° - -	22 - III	059 109 601 B 059 109 601 C	<b>331055</b>
	EX [2]	24,2 x 6 x 100,5	A/S - -	- 45° - VS -	22 - III	059 109 611 B	<b>331056</b>
	IN/EX [4]	10,06 x 6 x 42,0	B1				<b>81-33112</b>
	ES					059 109 021 BP 059 109 021 K 059 109 021 Q	<b>50 006 300</b> (1)
	ES					059 109 021 BQ 059 109 021 L 059 109 021 P	<b>50 006 301</b> (2)
	AS					059 109 022 BD 059 109 022 L 059 109 022 P	<b>50 006 302</b> (2)
	AS					059 109 022 BC 059 109 022 K 059 109 022 Q	<b>50 006 303</b> (1)
	(1) für Zylinder/for cylinder/pour cylindre/para cilindro/для цилиндров 1-3 für Zylinder/for cylinder/pour cylindre/para cilindro/для цилиндров 1-3 / Schalenhartguss/chilled cast iron/pièce moulée trempée en surface/fundición en coquilla/Отливка с отбелсным поверхностным слоем  (2) Schalenhartguss/chilled cast iron/pièce moulée trempée en surface/fundición en coquilla/Отливка с отбелсным поверхностным слоем						
	[8]	H 12 x 35 x 35				059 109 521 B 059 109 521 C 059 109 521 E	<b>50 006 411</b>
	[12]					059 109 444	<b>50 006 410</b>

					Reference	Item No.		
<b>124</b>		<b>78,3</b>						
<b>BAU</b>	01.2003 → 05.2005	D (LA)	6	2496 cm <sup>3</sup>	4V	132 kW (180 PS)	18,5	86,40 mm
<b>BDG</b>	05.2003 → 05.2005	D (LA)	6	2496 cm <sup>3</sup>	4V	120 kW (163 PS)	18,5	86,40 mm
<b>BDH</b>	01.2003 → 05.2005	D (LA)	6	2496 cm <sup>3</sup>	4V	132 kW (180 PS)	18,5	86,40 mm
99 534 6..., 99 535 6..., 99 542 6..., 99 543 6..								
	IN [2] EX [2]	27,2 x 6 x 100,6 24,1 x 6 x 100,7	S - Cr - RA/S- Cr -	- 45° - - 45° -	- VS -	22 - III 22 - III	059 109 601F 059 109 611G	<b>331110</b> <b>331111</b>
	IN/EX [4] IN/EX [4]	10,07 x 6 x 36,0 10,12 x 6 x 36,0	B1 B1					<b>81-3323</b> <b>81-3324</b>
		AS					059 109 009 BH 059 109 022 AF 059 109 022 BQ	<b>50 006 344</b> (1)
		AS					059 109 009 BJ 059 109 022 AG 059 109 022 BR	<b>50 006 345</b> (2)
		ES					059 106 021 CK 059 109 021 BA 059 109 021 CR	<b>50 006 346</b> (1)
		ES					059 109 021 AS 059 109 021 CL 059 109 021 CS	<b>50 006 347</b> (2)
	(1)	für Zylinder/for cylinder/pour cylindre/para cilindro/для цилиндров 1-3 / Schalenhartguss/chilled cast iron/pièce moulée trempée en surface/fundición en coquilla/Отливка с отбелнным поверхностным слоем						
	(2)	Cylinder 4-6 / Schalenhartguss/chilled cast iron/pièce moulée trempée en surface/fundición en coquilla/Отливка с отбелнным поверхностным слоем						
	[8]	H 12 x 32,6 x 32,6					059 109 521 G	<b>50 006 420</b>
<b>125</b>		<b>79,5</b>						
<b>FS</b>	08.1975 → 12.1995	B (NA)	4	1588 cm <sup>3</sup>	2V	53 kW (72 PS)	8,2	80,00 mm
<b>YG</b>	01.1975 → 11.1980	B (NA)	4	1588 cm <sup>3</sup>	2V	61 kW (83 PS)	8,2	80,00 mm
	IN/EX [4]	12,06/15 x 8 x 36,5	B1				056 103 419 A	<b>81-3310</b>
	[8]	M 35 x 28,5					056 109 311 A	<b>50 007 621</b>
<b>126</b>		<b>79,5</b>						
<b>EE</b>	03.1976 → 12.1977	B (NA)	4	1588 cm <sup>3</sup>	2V	60 kW (82 PS)	8,2:1	80,00 mm
<b>EF</b>		B	4	1588 cm <sup>3</sup>	2V	60 kW (82 PS)	8,2:1	80,00 mm
<b>EH</b>	08.1977 → 07.1979	B (NA)	4	1457 cm <sup>3</sup>	2V	53-57 kW (72-78 PS)	8,2	73,40 mm
<b>EN</b>	01.1980 → 12.1987	B (NA)	4	1715 cm <sup>3</sup>	2V	51-57 kW (75-78 PS)	8,2	86,40 mm
<b>FN</b>	08.1975 → 02.1984	B (NA)	4	1588 cm <sup>3</sup>	2V	53-57 kW (71-78 PS)	8	80,00 mm
<b>FT</b>	08.1975 → 07.1977	B (NA)	4	1588 cm <sup>3</sup>	2V	51 kW (70 PS)	8	80,00 mm
<b>GH</b>		B (NA)	4	1457 cm <sup>3</sup>	2V	48 kW (65 PS)	8,2:1	73,40 mm
<b>WY</b>	08.1979 → 11.1980	B (NA)	4	1588 cm <sup>3</sup>	2V	55 kW (75 PS)	8,2	80,00 mm
<b>WZ</b>	08.1979 → 07.1980	B (NA)	4	1588 cm <sup>3</sup>	2V	55 kW (75 PS)	8,2	80,00 mm
	[8]	M 35 x 28,5					056 109 311 A	<b>50 007 621</b>

V

					Reference	Item No.
<b>127</b>		<b>79,5</b>				
EM	08.1975 → 02.1984	B (NA)	4	1588 cm <sup>3</sup>	2V 55 kW (75 PS)	8,2:1 80,00 mm
FP	08.1975 → 02.1984	B (NA)	4	1588 cm <sup>3</sup>	2V 51-55 kW (70-75 PS)	8,2 80,00 mm
FR	08.1975 → 04.1984	B (NA)	4	1588 cm <sup>3</sup>	2V 63 kW (85 PS)	8,2 80,00 mm
FV		B (NA)	4	1588 cm <sup>3</sup>	2V 51 kW (70 PS)	8:1 80,00 mm
JB	08.1977 → 02.1984	B (NA)	4	1457 cm <sup>3</sup>	2V 51 kW (70 PS)	8,2 73,40 mm
WP		B (NA)	4	1588 cm <sup>3</sup>	2V 48 kW (65 PS)	8:1 80,00 mm
YP	08.1975 → 12.1996	B (NA)	4	1588 cm <sup>3</sup>	2V 61-63 kW (85 PS)	8,2 80,00 mm
	EX [2]	31,0 x 8 x 98,5	A/S - Cr -	- 45° - VS -	22 - III	049 109 611 F <b>33025</b>
	[50]	∅ 8 mm				113 109 651 A <b>MK-8H</b> 400 501 068
	IN/EX [4]	12,06/15 x 8 x 36,5	B1			056 103 419 A <b>81-3310</b>
	IN/EX [4]	12,07/15.2 x 8 x 42,5	B1			049 103 419 <b>81-3319</b>
	IN/EX [4]	12,13/15 x 8 x 36,5	B1			<b>81-3312</b>
	IN/EX [4]	12,20/15 x 8 x 36,5	B1			<b>81-3311</b>
	IN/EX [4]	12,20/15.2 x 8 x 42,5	B1			<b>81-3320</b>
	[8]	M 35 x 28,5				056 109 311 A <b>50 007 621</b>
<b>128</b>		<b>79,5</b>				
EG	06.1976 → 07.1982	B (NA)	4	1588 cm <sup>3</sup>	2V 81 kW (110 PS)	9,5 80,00 mm
	IN/EX [4]	12,06/15 x 8 x 36,5	B1			056 103 419 A <b>81-3310</b>
	IN/EX [4]	12,07/15.2 x 8 x 42,5	B1			049 103 419 <b>81-3319</b>
	IN/EX [4]	12,13/15 x 8 x 36,5	B1			<b>81-3312</b>
	IN/EX [4]	12,20/15 x 8 x 36,5	B1			<b>81-3311</b>
	IN/EX [4]	12,20/15.2 x 8 x 42,5	B1			<b>81-3320</b>
	[8]	M 35 x 28,5				056 109 311 A <b>50 007 621</b>
<b>129</b>		<b>79,5</b>				
YS	06.1978 → 07.1980	B (NA)	4	1588 cm <sup>3</sup>	2V 81 kW (110 PS)	9,5 80,00 mm
	IN/EX [4]	12,06/15 x 8 x 36,5	B1			056 103 419 A <b>81-3310</b>
	IN/EX [4]	12,07/15.2 x 8 x 42,5	B1			049 103 419 <b>81-3319</b>
	IN/EX [4]	12,13/15 x 8 x 36,5	B1			<b>81-3312</b>
	IN/EX [4]	12,20/15 x 8 x 36,5	B1			<b>81-3311</b>
	IN/EX [4]	12,20/15.2 x 8 x 42,5	B1			<b>81-3320</b>
<b>130</b>		<b>79,5</b>				
WN	01.1981 → 1984	B (NA)	5	1921 cm <sup>3</sup>	2V 85 kW (115 PS)	10 77,40 mm
	IN [2]	38,0 x 8 x 98,6	S - -	- 45° - -	22 - III	035 109 601 C <b>33022</b> 035 109 601 D 035 109 601 F 035 109 603
	EX [2]	33,0 x 8 x 98,5	A/S - Cr -	- 45° - VS -	22 - III	035 109 611 F <b>33023</b> 035 109 611 H
	[50]	∅ 8 mm				113 109 651 A <b>MK-8H</b> 400 501 068
	IN/EX [4]	12,06/15 x 8 x 36,5	B1			056 103 419 A <b>81-3310</b>
	IN/EX [4]	12,07/15.2 x 8 x 42,5	B1			049 103 419 <b>81-3319</b>
	IN/EX [4]	12,13/15 x 8 x 36,5	B1			<b>81-3312</b>
	IN/EX [4]	12,20/15 x 8 x 36,5	B1			<b>81-3311</b>
	IN/EX [4]	12,20/15.2 x 8 x 42,5	B1			<b>81-3320</b>

V



KOLBENSCHMIDT

TRW  
EngineComponents

## VOLKSWAGEN

					Reference	Item No.		
<b>131</b>		<b>79,5</b>						
<b>WT</b>	08.1981 → 12.1983	B (NA)	4	1715 cm <sup>3</sup>	2V	55-58 kW (74-79 PS)	8,2:1	86,40 mm
<b>VV</b>	08.1981 → 07.1983	B (NA)	4	1588 cm <sup>3</sup>	2V	55 kW (75 PS)	8,2	80,00 mm
	EX [2]	31,0 x 8 x 98,5	A/S - Cr -	- 45° - VS -	22 - III	049 109 611 F		<b>33025</b>
	[50]	∅ 8 mm				113 109 651 A 400 501 068		<b>MK-8H</b>
	IN/EX [4]	12,06/15 x 8 x 36,5	B1			056 103 419 A		<b>81-3310</b>
	IN/EX [4]	12,07/15.2 x 8 x 42,5	B1			049 103 419		<b>81-3319</b>
	IN/EX [4]	12,13/15 x 8 x 36,5	B1					<b>81-3312</b>
	IN/EX [4]	12,20/15 x 8 x 36,5	B1					<b>81-3311</b>
	IN/EX [4]	12,20/15.2 x 8 x 42,5	B1					<b>81-3320</b>
<b>132</b>		<b>79,5</b>						
<b>YH</b>	01.1975 → 11.1996	AB (NA)	4	1588 cm <sup>3</sup>	2V	57-61 kW (77-83 PS)	8,2	80,00 mm
	IN/EX [4]	12,06/15 x 8 x 36,5	B1			056 103 419 A		<b>81-3310</b>
<b>133</b>		<b>79,5</b>						
<b>KY</b>	08.1984 → 07.1992	D (NA)	4	1715 cm <sup>3</sup>	2V	42 kW (57 PS)	23	86,40 mm
	IN [2]	36,0 x 8 x 104,9	A/S - -	- 45° - -	22 - III	069 109 601 D		<b>33044</b>
	EX [2]	31,0 x 8 x 104,7	A/S - -	- 45° - -	22 - III			<b>331101</b>
	[50]	∅ 8 mm				113 109 651 A 400 501 068		<b>MK-8H</b>
	IN/EX [4]	12,06/15 x 8 x 36,5	B1			056 103 419 A		<b>81-3310</b>
	IN/EX [4]	12,07/15.2 x 8 x 42,5	B1			049 103 419		<b>81-3319</b>
	IN/EX [4]	12,13/15 x 8 x 36,5	B1					<b>81-3312</b>
	IN/EX [4]	12,20/15 x 8 x 36,5	B1					<b>81-3311</b>
	IN/EX [4]	12,20/15.2 x 8 x 42,5	B1					<b>81-3320</b>
	[8]	M 35 x 28,5				056 109 311 A		<b>50 007 621</b>
<b>134</b>		<b>79,5</b>						
<b>1Y</b>	05.1989 →	D (NA)	4	1896 cm <sup>3</sup>	2V	47-50 kW (64-68 PS)	22,5	95,50 mm
91 386 6..								
	IN [2]	36,0 x 7 x 95,6	S - -	- 45° - -	22 - III	028 109 601 B		<b>39395</b>
	IN [2]	36,0 x 8 x 95,6	S - -	- 45° - -	22 - III	069 109 601 F		<b>39123</b>
	EX [2]	31,0 x 7 x 95,6	A/S - -	- 45° - VS -	22 - III	028 109 611 E		<b>39474</b>
	EX [2]	31,2 x 8 x 95,1	A/S - -	- 45° - VS -	22 - III	074 109 611		<b>33049</b>
	EX [2]	31,2 x 8 x 95,6	RA/S- Cr -	- 45° - VS -	22 - III	074 109 611		<b>39185</b>
	[50]	∅ 7 mm				021 109 651		<b>MK-7H</b>
	[50]	∅ 8 mm				113 109 651 A 400 501 068		<b>MK-8H</b>
	IN/EX [4]	12,06/15 x 8 x 36,5	B1			056 103 419 A		<b>81-3310</b>
	IN/EX [4]	12,08/15 x 7 x 36,5	B1			037 103 415 037 103 419 B		<b>81-33103</b>
	IN/EX [4]	12,13/15 x 8 x 36,5	B1					<b>81-3312</b>
	IN/EX [4]	12,20/15 x 8 x 36,5	B1					<b>81-3311</b>
	IN/EX [4]	12,25/15 x 7 x 36,5	B1					<b>81-33104</b>
						028 109 101 D 028 109 101 G		<b>50 006 203</b> (1)
	(1)	Schalenhartguss/chilled cast iron/pièce moulée trempée en surface/fundición en coquilla/Отливка с отбелсным поверхностным слоем						
Fortsetzung nächste Seite / continued on next page / suite page suivante / continuación página próxima / Продолжение на следующей странице								

V

					Reference	Item No.
[8]	H 35 x 26 x 26				034 109 309 034 109 309 AC 034 109 309 AD 034 109 309 N 074 109 309	<b>50 006 460</b>
	- - G - S - PC - SB - -		 40 Nm 60 Nm 180° 90°		028 103 351 M	<b>50 003 107</b> (2)
	- - G - S - PC - SB - -		 40 Nm 60 Nm 180° 90°		028 103 351 028 103 351 D	<b>50 003 069</b> (3)
	<p>(2) Ventilschaft/valve stem/tige de soupape/cana de válvula/Стержень клапана Ø 7 mm</p> <p>(3) Vorkammerbohrung/prechamber bore/alésage pour la préchambre/alojamiento de la precámara/ Отверстие форкамеры Ø 32 mm / Hydrostößel/hydraulic tappets/poussoirs hydrauliques/ empujadores hidráulicos/Гидротолкатель / Ventilschaft/valve stem/tige de soupape/cana de válvula/ Стержень клапана Ø 8 mm</p>					

## 135

**79,5**

1X 07.1990 → 12.1995 D (NA) 4 1896 cm<sup>3</sup> 2V 44-45 kW (60-61 PS) 22,5 95,50 mm  
91 386 6..

	IN [2] EX [2] EX [2]	36,0 x 8 x 95,6 31,2 x 8 x 95,1 31,2 x 8 x 95,6	S - - A/S - - RA/S- Cr -	- 45° - - - 45° - VS - - 45° - VS -	22 - III 22 - III 22 - III	069 109 601 F 074 109 611 074 109 611	<b>39123</b> <b>33049</b> <b>39185</b>
	[50]	Ø 8 mm				113 109 651 A 400 501 068	<b>MK-8H</b>
	IN/EX [4] IN/EX [4] IN/EX [4]	12,06/15 x 8 x 36,5 12,13/15 x 8 x 36,5 12,20/15 x 8 x 36,5	B1 B1 B1			056 103 419 A	<b>81-3310</b> <b>81-3312</b> <b>81-3311</b>
[8]	H 35 x 26 x 26					034 109 309 034 109 309 AC 034 109 309 AD 034 109 309 N 074 109 309	<b>50 006 460</b>

## 136

**79,5**

AAB 07.1990 → 09.1998 D (NA) 5 2370 cm<sup>3</sup> 2V 57 kW (78 PS) 23 95,50 mm  
91 386 6..

	IN [2] EX [2] EX [2]	36,0 x 8 x 95,6 31,2 x 8 x 95,1 31,2 x 8 x 95,6	S - - A/S - - RA/S- Cr -	- 45° - - - 45° - VS - - 45° - VS -	22 - III 22 - III 22 - III	069 109 601 F 074 109 611 074 109 611	<b>39123</b> <b>33049</b> <b>39185</b>
	[50]	Ø 8 mm				113 109 651 A 400 501 068	<b>MK-8H</b>
	IN/EX [4] IN/EX [4] IN/EX [4]	12,06/15 x 8 x 36,5 12,13/15 x 8 x 36,5 12,20/15 x 8 x 36,5	B1 B1 B1			056 103 419 A	<b>81-3310</b> <b>81-3312</b> <b>81-3311</b>

Fortsetzung nächste Seite / continued on next page / suite page suivante / continuación página próxima / Продолжение на следующей странице



					Reference	Item No.
					074 109 101 A 069 109 101P 074 109 101 B	<b>50 006 215</b> (1) <b>50 006 216</b> (1)
(1)	Schalenhartguss/chilled cast iron/pièce moulée trempée en surface/fundición en coquilla/Отливка с отбеленным поверхностным слоем					
	[8]	H 35 x 26 x 26			034 109 309 034 109 309 AC 034 109 309 AD 034 109 309 N 074 109 309	<b>50 006 460</b>
		- - G - S - PC - SB - -		35 Nm 60 Nm 2 x 90° 90° warm/chaud/caliente	074 103 351 D	<b>50 003 113</b> (2)
		- - G - S - PC - SB - -		35 Nm 60 Nm 2 x 90° 90° warm/chaud/caliente	074 103 351 A	<b>50 003 101</b> (3)
(2)	Vorkammerbohrung/prechamber bore/alésage pour la préchambre/alojamiento de la precámara/ Отверстие форкамеры Ø 32 mm / Hydrostößel/hydraulic tappets/poussoirs hydrauliques/ empujadores hidráulicos/Гидротолкатель Zylinderkopfdeckelfläche ohne Bohrungen Without drill holes to fit rocker gasket Sans trous de fixation sur le plan de joint du cache culbuteurs Sin taladros para fijación de junta de balancines Поверхность крышки головки блока цилиндров без отверстий					
(3)	Vorkammerbohrung/prechamber bore/alésage pour la préchambre/alojamiento de la precámara/ Отверстие форкамеры Ø 32 mm / Hydrostößel/hydraulic tappets/poussoirs hydrauliques/ empujadores hidráulicos/Гидротолкатель Zylinderkopfdeckelfläche mit 11 Bohrungen Ø 5 mm With 11 drill holes Ø 5 mm to fit rocker gasket 11 trous de Ø 5 mm pour la fixation du cache culbuteurs Con 11 taladros Ø 5 mm para fijación de junta de balancines Поверхность крышки головки блока цилиндров с 11 отверстиями Ø 5 мм					

**137**
**79,5**
**AAZ** 03.1991 → 05.2002 D (A) 4 1896 cm<sup>3</sup> 2V 55 kW (75 PS) 22,5 95,50 mm  
91 429 6..

	IN [2]	36,0 x 7 x 95,6	S - -	- 45° - -	22 - III	028 109 601 B	<b>39395</b>
	IN [2]	36,0 x 8 x 95,6	RA/S- -	- 45° - VS -	22 - III	069 109 601 H	<b>39143</b>
	EX [2]	31,0 x 7 x 95,6	A/S - -	- 45° - VS -	22 - III	028 109 611 E	<b>39474</b>
	EX [2]	31,2 x 8 x 95,1	A/S - -	- 45° - VS -	22 - III	074 109 611	<b>33049</b>
	EX [2]	31,2 x 8 x 95,6	RA/S- Cr -	- 45° - VS -	22 - III	074 109 611	<b>39185</b>
	[50]	Ø 7 mm				021 109 651	<b>MK-7H</b>
	[50]	Ø 8 mm				113 109 651 A 400 501 068	<b>MK-8H</b>
	IN/EX [4]	12,06/15 x 8 x 36,5	B1			056 103 419 A	<b>81-3310</b>
	IN/EX [4]	12,08/15 x 7 x 36,5	B1			037 103 415 037 103 419 B	<b>81-33103</b>
	IN/EX [4]	12,13/15 x 8 x 36,5	B1				<b>81-3312</b>
	IN/EX [4]	12,20/15 x 8 x 36,5	B1				<b>81-3311</b>
	IN/EX [4]	12,25/15 x 7 x 36,5	B1				<b>81-33104</b>

Fortsetzung nächste Seite / continued on next page / suite page suivante / continuación página próxima / Продолжение на следующей странице

					Reference	Item No.
					028 109 101 D 028 109 101 G	<b>50 006 203</b> (1)
	(1)	Schalenhartguss/chilled cast iron/pièce moulée trempée en surface/fundición en coquilla/Отливка с отбелсным поверхностным слоем				
	[8]	H 35 x 26 x 26			034 109 309 034 109 309 AC 034 109 309 AD 034 109 309 N 074 109 309	<b>50 006 460</b>

**138**
**79,5**
**1Z** 08.1991 → 03.2010 D (A) 4 1896 cm<sup>3</sup> 2V 66 kW (90 PS) 19,5 95,50 mm  
 94 427 7..., 94 428 7..

	IN [2]	36,0 x 7 x 96,9	S - -	- 45° - -	22 - III	028 109 601 D	<b>39486</b>
	IN [2]	36,0 x 8 x 96,9	RA/S- -	- 45° - VS -	22 - III	028 109 601 H 028 109 601A 046 109 601G 046 109 601J 049 109 601J	<b>39423</b> (1)
	IN [2]	36,1 x 8 x 96,9	S - -	- 45° - -	22 - III		<b>331141</b> (2)
	EX [2]	31,6 x 7 x 96,9	RA/S- -	- 45° - -	22 - III	028 109 611G	<b>331143</b>
	EX [2]	31,6 x 8 x 96,9	RA/S- -	- 45° - -	22 - III	046 109 611 C 046 109 611 E 046 109 611 F	<b>331142</b>
	(1)	OES specification					
	(2)	IAM specification					
	[50]	∅ 7 mm				021 109 651 113 109 651 A 400 501 068	<b>MK-7H</b> <b>MK-8H</b>
	[50]	∅ 8 mm					
	IN/EX [4]	12,06/15 x 8 x 36,5	B1			056 103 419 A	<b>81-3310</b>
	IN/EX [4]	12,08/15 x 7 x 36,5	B1			037 103 415 037 103 419 B	<b>81-33103</b>
	IN/EX [4]	12,13/15 x 8 x 36,5	B1				<b>81-3312</b>
	IN/EX [4]	12,20/15 x 8 x 36,5	B1				<b>81-3311</b>
	IN/EX [4]	12,25/15 x 7 x 36,5	B1				<b>81-33104</b>
						028 109 101 F	<b>50 006 205</b> (3)
	(3)	Schalenhartguss/chilled cast iron/pièce moulée trempée en surface/fundición en coquilla/Отливка с отбелсным поверхностным слоем					
	[8]	H 35 x 26 x 26				034 109 309 034 109 309 AC 034 109 309 AD 034 109 309 N 074 109 309	<b>50 006 460</b>
	[8]	H 12 x 64					<b>50 007 596</b>

**139**
**79,5**
**ABL** 10.1992 → D (A) 4 1896 cm<sup>3</sup> 2V 50 kW (68 PS) 22,5 95,50 mm  
 91 429 6..

	IN [2]	36,0 x 7 x 95,6	S - -	- 45° - -	22 - III	028 109 601 B	<b>39395</b>
	IN [2]	36,0 x 8 x 95,6	RA/S- -	- 45° - VS -	22 - III	069 109 601 H	<b>39143</b>
	EX [2]	31,0 x 7 x 95,6	A/S - -	- 45° - VS -	22 - III	028 109 611 E	<b>39474</b>
	EX [2]	31,2 x 8 x 95,1	A/S - -	- 45° - VS -	22 - III	074 109 611	<b>33049</b>
	EX [2]	31,2 x 8 x 95,6	RA/S- Cr -	- 45° - VS -	22 - III	074 109 611	<b>39185</b>
	[50]	∅ 7 mm				021 109 651 113 109 651 A 400 501 068	<b>MK-7H</b> <b>MK-8H</b>
	[50]	∅ 8 mm					

Fortsetzung nächste Seite / continued on next page / suite page suivante / continuación página próxima / Продолжение на следующей странице

					Reference	Item No.
	IN/EX [4] 12,06/15 x 8 x 36,5 IN/EX [4] 12,08/15 x 7 x 36,5	B1 B1			056 103 419 A 037 103 415 037 103 419 B	<b>81-3310</b> <b>81-33103</b>
	IN/EX [4] 12,13/15 x 8 x 36,5 IN/EX [4] 12,20/15 x 8 x 36,5 IN/EX [4] 12,25/15 x 7 x 36,5	B1 B1 B1				<b>81-3312</b> <b>81-3311</b> <b>81-33104</b>
	[8] H 35 x 26 x 26				050 109 309 050 109 309 A 050 109 309 H 050 109 309 J	<b>50 006 417</b>
	- - G - S - PC - SB - -  			30 Nm 60 Nm 2 x 90°	028 103 351 L	<b>50 003 108</b> (1)

(1) Ventilschaft/valve stem/tige de soupape/cana de válvula/Стержень клапана Ø 7 mm

## 140 79,5

<b>AFN</b>	03.1996 → 05.2003	D (LA)	4	1896 cm <sup>3</sup>	2V	81 kW	(110 PS)	19,5	95,50 mm
<b>AHU</b>	08.1993 → 03.2010	D (A)	4	1896 cm <sup>3</sup>	2V	66-67 kW	(90-91 PS)	19,5	95,50 mm

94 427 7.., 94 428 7..

	IN [2] 36,0 x 7 x 96,9 IN [2] 36,0 x 8 x 96,9	S - - RA/S- -	- 45° - - - 45° - VS -	22 - III 22 - III	028 109 601 D 028 109 601 H 028 109 601A 046 109 601G 046 109 601J 049 109 601J	<b>39486</b> <b>39423</b> (1)
	IN [2] 36,1 x 8 x 96,9 EX [2] 31,6 x 7 x 96,9 EX [2] 31,6 x 8 x 96,9	S - - RA/S- - RA/S- -	- 45° - - - 45° - - - 45° - -	22 - III 22 - III 22 - III	028 109 611G 046 109 611 C 046 109 611 E 046 109 611 F	<b>331141</b> (2) <b>331143</b> <b>331142</b>
	(1) OES specification (2) IAM specification					
	[50] Ø 7 mm [50] Ø 8 mm				021 109 651 113 109 651 A 400 501 068	<b>MK-7H</b> <b>MK-8H</b>
	IN/EX [4] 12,06/15 x 8 x 36,5 IN/EX [4] 12,08/15 x 7 x 36,5	B1 B1			056 103 419 A 037 103 415 037 103 419 B	<b>81-3310</b> <b>81-33103</b>
	IN/EX [4] 12,13/15 x 8 x 36,5 IN/EX [4] 12,20/15 x 8 x 36,5 IN/EX [4] 12,25/15 x 7 x 36,5	B1 B1 B1				<b>81-3312</b> <b>81-3311</b> <b>81-33104</b>
					028 109 101 F	<b>50 006 205</b> (3)
	(3) Schalenhartguss/chilled cast iron/pièce moulée trempée en surface/fundición en coquilla/Отливка с отбелсным поверхностным слоем					
	[8] H 35 x 26 x 26				034 109 309 034 109 309 AC 034 109 309 AD 034 109 309 N 074 109 309	<b>50 006 460</b>

## 141 79,5

<b>ADE</b>	04.1994 → 01.2002	D (A)	4	1896 cm <sup>3</sup>	2V	56 kW	(76 PS)	22,5:1	95,50 mm
------------	-------------------	-------	---	----------------------	----	-------	---------	--------	----------

91 429 6..

Fortsetzung nächste Seite / continued on next page / suite page suivante / continuación página próxima / Продолжение на следующей странице

					Reference	Item No.	
	IN [2]	36,0 x 7 x 95,6	S - -	- 45° - -	22 - III	028 109 601 B	<b>39395</b>
	IN [2]	36,0 x 8 x 95,6	RA/S- -	- 45° - VS -	22 - III	069 109 601 H	<b>39143</b>
	EX [2]	31,0 x 7 x 95,6	A/S - -	- 45° - VS -	22 - III	028 109 611 E	<b>39474</b>
	EX [2]	31,2 x 8 x 95,1	A/S - -	- 45° - VS -	22 - III	074 109 611	<b>33049</b>
	EX [2]	31,2 x 8 x 95,6	RA/S- Cr -	- 45° - VS -	22 - III	074 109 611	<b>39185</b>
	[50]	Ø 7 mm				021 109 651	<b>MK-7H</b>
	[50]	Ø 8 mm				113 109 651 A 400 501 068	<b>MK-8H</b>
	IN/EX [4]	12,06/15 x 8 x 36,5	B1			056 103 419 A	<b>81-3310</b>
	IN/EX [4]	12,08/15 x 7 x 36,5	B1			037 103 415 037 103 419 B	<b>81-33103</b>
	IN/EX [4]	12,13/15 x 8 x 36,5	B1				<b>81-3312</b>
	IN/EX [4]	12,20/15 x 8 x 36,5	B1				<b>81-3311</b>
	IN/EX [4]	12,25/15 x 7 x 36,5	B1				<b>81-33104</b>

## 142

**79,5**

**ADG** 91 386 6.. 04.1994 → D (NA) 4 1896 cm<sup>3</sup> 2V 43 kW (58 PS) 22,5:1 95,50 mm

	IN [2]	36,0 x 7 x 95,6	S - -	- 45° - -	22 - III	028 109 601 B	<b>39395</b>
	EX [2]	31,0 x 7 x 95,6	A/S - -	- 45° - VS -	22 - III	028 109 611 E	<b>39474</b>
	[50]	Ø 7 mm				021 109 651	<b>MK-7H</b>
	IN/EX [4]	12,08/15 x 7 x 36,5	B1			037 103 415 037 103 419 B	<b>81-33103</b>
	IN/EX [4]	12,25/15 x 7 x 36,5	B1				<b>81-33104</b>
		- - G - S - PC - SB - -				028 103 351 M	<b>50 003 107</b> (1)

40 Nm  
60 Nm  
180°  
90°

(1) Ventilschaft/valve stem/tige de soupape/cana de válvula/Стержень клапана Ø 7 mm

## 143

**79,5**

**AFD** 94 427 7.., 94 428 7.. 04.1994 → 01.2002 D (A) 4 1896 cm<sup>3</sup> 2V 58 kW (79 PS) 22,5:1 95,50 mm

**BEU** 11.2002 → D (A) 4 1896 cm<sup>3</sup> 2V 43 kW (58 PS) 19,5:1 95,50 mm

	IN [2]	36,0 x 7 x 96,9	S - -	- 45° - -	22 - III	028 109 601 D	<b>39486</b>
	EX [2]	31,6 x 7 x 96,9	RA/S- -	- 45° - -	22 - III	028 109 611G	<b>331143</b>
	[50]	Ø 7 mm				021 109 651	<b>MK-7H</b>
	IN/EX [4]	12,08/15 x 7 x 36,5	B1			037 103 415 037 103 419 B	<b>81-33103</b>
	IN/EX [4]	12,25/15 x 7 x 36,5	B1				<b>81-33104</b>

## 144

**79,5**

**AEF** 91 386 6.. 10.1994 → 09.2001 D (NA) 4 1896 cm<sup>3</sup> 2V 47 kW (64 PS) 22,5 95,50 mm

Fortsetzung nächste Seite / continued on next page / suite page suivante / continuación página próxima / Продолжение на следующей странице

					Reference	Item No.	
	IN [2] IN [2] IN [2] EX [2] EX [2] EX [2] EX [2]	36,0 x 7 x 95,6 36,0 x 7 x 96,6 36,0 x 8 x 95,6 31,0 x 7 x 95,6 31,2 x 8 x 95,1 31,2 x 8 x 95,6 31,5 x 7 x 96,4	S - - S - - S - - A/S - - A/S - - RA/S- Cr - RA/S- -	- 45° - - - 45° - - - 45° - - - 45° - VS - - 45° - VS - - 45° - VS - - 45° - VS -	22 - III 22 - III 22 - III 22 - III 22 - III 22 - III 22 - III	028 109 601 B 028 109 601 J 069 109 601 F 028 109 611 E 074 109 611 074 109 611 028 109 611 K	<b>39395</b> <b>39502</b> <b>39123</b> <b>39474</b> <b>33049</b> <b>39185</b> <b>39503</b>
	[50] [50]	Ø 7 mm Ø 8 mm				021 109 651 113 109 651 A 400 501 068	<b>MK-7H</b> <b>MK-8H</b>
	IN/EX [4] IN/EX [4]  IN/EX [4] IN/EX [4] IN/EX [4]	12,06/15 x 8 x 36,5 12,08/15 x 7 x 36,5  12,13/15 x 8 x 36,5 12,20/15 x 8 x 36,5 12,25/15 x 7 x 36,5	B1 B1  B1 B1 B1			056 103 419 A 037 103 415 037 103 419 B	<b>81-3310</b> <b>81-33103</b>  <b>81-3312</b> <b>81-3311</b> <b>81-33104</b>
						028 109 101 E	<b>50 006 204</b> (1)
	(1)	(1) Schalenhartguss/chilled cast iron/pièce moulée trempée en surface/fundición en coquilla/Отливка с отбеленным поверхностным слоем					
	[8]	H 35 x 26 x 26				050 109 309 050 109 309 A 050 109 309 H 050 109 309 J	<b>50 006 417</b>

## 145 79,5

<b>AEY</b>	D (NA) 4	1896 cm <sup>3</sup>	2V	47-48 kW	(64-65 PS)	19,5	95,50 mm
<b>AGD</b>	D (NA) 4	1896 cm <sup>3</sup>	2V	47 kW	(64 PS)	19,5	95,50 mm

94 427 7... 94 428 7..

	IN [2] IN [2] EX [2] EX [2] EX [2]	36,0 x 7 x 96,6 36,0 x 8 x 95,6 31,2 x 8 x 95,1 31,2 x 8 x 95,6 31,5 x 7 x 96,4	S - - S - - A/S - - RA/S- Cr - RA/S- -	- 45° - - - 45° - - - 45° - VS - - 45° - VS - - 45° - VS -	22 - III 22 - III 22 - III 22 - III 22 - III	028 109 601 J 069 109 601 F 074 109 611 074 109 611 028 109 611 K	<b>39502</b> <b>39123</b> <b>33049</b> <b>39185</b> <b>39503</b>
	[50] [50]	Ø 7 mm Ø 8 mm				021 109 651 113 109 651 A 400 501 068	<b>MK-7H</b> <b>MK-8H</b>
	IN/EX [4] IN/EX [4]  IN/EX [4] IN/EX [4] IN/EX [4]	12,06/15 x 8 x 36,5 12,08/15 x 7 x 36,5  12,13/15 x 8 x 36,5 12,20/15 x 8 x 36,5 12,25/15 x 7 x 36,5	B1 B1  B1 B1 B1			056 103 419 A 037 103 415 037 103 419 B	<b>81-3310</b> <b>81-33103</b>  <b>81-3312</b> <b>81-3311</b> <b>81-33104</b>
						028 109 101 E	<b>50 006 204</b> (1)
	(1)	(1) Schalenhartguss/chilled cast iron/pièce moulée trempée en surface/fundición en coquilla/Отливка с отбеленным поверхностным слоем					
	[8]	H 35 x 26 x 26				034 109 309 034 109 309 AC 034 109 309 AD 034 109 309 N 074 109 309	<b>50 006 460</b>

## 146 79,5

<b>ALE</b>	D (LA) 4	1896 cm <sup>3</sup>	2V	66 kW	(90 PS)	19,5	95,50 mm
------------	----------	----------------------	----	-------	---------	------	----------

94 427 7... 94 428 7..

Fortsetzung nächste Seite / continued on next page / suite page suivante / continuación página próxima / Продолжение на следующей странице

					Reference	Item No.
IN [2] EX [2]	36,0 x 7 x 96,9 31,6 x 7 x 96,9	S - - RA/S- -	- 45° - - - 45° - -	22 - III 22 - III	028 109 601 D 028 109 611 G	<b>39486</b> <b>331143</b>
[50]	Ø 7 mm				021 109 651	<b>MK-7H</b>
IN/EX [4] IN/EX [4]	12,08/15 x 7 x 36,5 12,25/15 x 7 x 36,5	B1 B1			037 103 415 037 103 419 B	<b>81-33103</b> <b>81-33104</b>
[8]	H 35 x 26 x 26				034 109 309 034 109 309 AC 034 109 309 AD 034 109 309 N 074 109 309	<b>50 006 460</b>

## 147 79,5

<b>AQM</b>	08.1997 →	D (NA)	4	1896 cm <sup>3</sup>	2V	50 kW	(68 PS)	19,5	95,50 mm
<b>ASY</b>	10.2001 →	D (NA)	4	1896 cm <sup>3</sup>	2V	47 kW	(64 PS)	19,5	95,50 mm
<b>AYQ</b>	11.1995 → 01.2004	D (NA)	4	1896 cm <sup>3</sup>	2V	47 kW	(64 PS)	19,5:1	95,50 mm

40 092 7..., 40 093 7..

IN [2] EX [2]	36,0 x 7 x 96,6 31,5 x 7 x 96,4	S - - RA/S- -	- 45° - - - 45° - VS -	22 - III 22 - III	028 109 601 J 028 109 611 K	<b>39502</b> <b>39503</b>
[50]	Ø 7 mm				021 109 651	<b>MK-7H</b>
IN/EX [4] IN/EX [4]	12,08/15 x 7 x 36,5 12,25/15 x 7 x 36,5	B1 B1			037 103 415 037 103 419 B	<b>81-33103</b> <b>81-33104</b>
					038 109 101 E	<b>50 006 210</b> (1)
(1) Schalenhartguss/chilled cast iron/pièce moulée trempée en surface/fundición en coquilla/Отливка с отбелсным поверхностным слоем						
[8]	H 35 x 26 x 26				050 109 309 050 109 309 A 050 109 309 H 050 109 309 J	<b>50 006 417</b>

## 148 79,5

<b>AHB</b>	07.1996 → 09.2000	D (NA)	4	1715 cm <sup>3</sup>	2V	42 kW	(57 PS)	19,5	86,40 mm
<b>AHG</b>	04.1997 → 10.1999	D (NA)	4	1716 cm <sup>3</sup>	2V	42-44 kW	(57-60 PS)	19,5	86,40 mm
<b>AKU</b>	08.1997 → 07.2005	D (NA)	4	1716 cm <sup>3</sup>	2V	44 kW	(60 PS)	19,5	86,40 mm
<b>ASX</b>	10.1999 → 09.2001	D (NA)	4	1896 cm <sup>3</sup>	2V	47 kW	(64 PS)	22,5:1	95,50 mm

94 427 7..., 94 428 7..

IN [2] EX [2]	36,0 x 7 x 96,6 31,5 x 7 x 96,4	S - - RA/S- -	- 45° - - - 45° - VS -	22 - III 22 - III	028 109 601 J 028 109 611 K	<b>39502</b> <b>39503</b>
[50]	Ø 7 mm				021 109 651	<b>MK-7H</b>
IN/EX [4] IN/EX [4]	12,08/15 x 7 x 36,5 12,25/15 x 7 x 36,5	B1 B1			037 103 415 037 103 419 B	<b>81-33103</b> <b>81-33104</b>
					028 109 101 E	<b>50 006 204</b> (1)
(1) Schalenhartguss/chilled cast iron/pièce moulée trempée en surface/fundición en coquilla/Отливка с отбелсным поверхностным слоем						

Fortsetzung nächste Seite / continued on next page / suite page suivante / continuación página próxima / Продолжение на следующей странице



					Reference	Item No.
[8]	H 35 x 26 x 26				034 109 309 034 109 309 AC 034 109 309 AD 034 109 309 N 074 109 309	<b>50 006 460</b>

<b>149</b>		<b>79,5</b>						
<b>AVG</b>	09.1996 → 06.2002	D (A)	4	1896 cm <sup>3</sup>	2V	81 kW	(110 PS) 19,5	95,50 mm
94 427 7..., 94 428 7..								

	IN [2]	36,0 x 7 x 96,9	S - -	- 45° - -	22 - III	028 109 601 D	<b>39486</b>
	EX [2]	31,6 x 7 x 96,9	RA/S- -	- 45° - -	22 - III	028 109 611 G	<b>331143</b>
	[50]	Ø 7 mm				021 109 651	<b>MK-7H</b>
	IN/EX [4]	12,08/15 x 7 x 36,5	B1			037 103 415 037 103 419 B	<b>81-33103</b>
	IN/EX [4]	12,25/15 x 7 x 36,5	B1				<b>81-33104</b>
						028 109 101 F	<b>50 006 205</b> (1)
	(1) Schalenhartguss/chilled cast iron/pièce moulée trempée en surface/fundición en coquilla/Отливка с отбеленным поверхностным слоем						
[8]	H 35 x 26 x 26					050 109 309 050 109 309 A 050 109 309 H 050 109 309 J	<b>50 006 417</b>

<b>150</b>		<b>79,5</b>						
<b>ALH</b>	09.1996 → 05.2006	D (LA)	4	1896 cm <sup>3</sup>	2V	66-67 kW	(90-91 PS) 19,5	95,50 mm
<b>ASV</b>	08.1997 → 05.2006	D (LA)	4	1896 cm <sup>3</sup>	2V	81 kW	(110 PS) 19,5	95,50 mm
94 427 7..., 94 428 7..								

	IN [2]	36,0 x 7 x 96,9	S - -	- 45° - -	22 - III	028 109 601 D	<b>39486</b>
	EX [2]	31,6 x 7 x 96,9	RA/S- -	- 45° - -	22 - III	028 109 611 G	<b>331143</b>
	[50]	Ø 7 mm				021 109 651	<b>MK-7H</b>
	IN/EX [4]	12,08/15 x 7 x 36,5	B1			037 103 415 037 103 419 B	<b>81-33103</b>
	IN/EX [4]	12,25/15 x 7 x 36,5	B1				<b>81-33104</b>
						038 109 101 K	<b>50 006 202</b> (1)
	(1) Schalenhartguss/chilled cast iron/pièce moulée trempée en surface/fundición en coquilla/Отливка с отбеленным поверхностным слоем						
[8]	H 35 x 26 x 26					050 109 309 050 109 309 A 050 109 309 H 050 109 309 J	<b>50 006 417</b>

<b>151</b>		<b>79,5</b>						
<b>AGR</b>		D (LA)	4	1896 cm <sup>3</sup>	2V	66 kW	(90 PS) 19,5	95,50 mm
<b>AHF</b>	08.1997 → 05.2006	D (LA)	4	1896 cm <sup>3</sup>	2V	81 kW	(110 PS) 19,5	95,50 mm
94 427 7..., 94 428 7..								

	IN [2]	36,0 x 7 x 96,9	S - -	- 45° - -	22 - III	028 109 601 D	<b>39486</b>	
	EX [2]	31,6 x 7 x 96,9	RA/S- -	- 45° - -	22 - III	028 109 611 G	<b>331143</b>	
	[50]	Ø 7 mm				021 109 651	<b>MK-7H</b>	
Fortsetzung nächste Seite / continued on next page / suite page suivante / continuación página próxima / Продолжение на следующей странице								

					Reference	Item No.
	IN/EX [4] 12,08/15 x 7 x 36,5	B1			037 103 415 037 103 419 B	<b>81-33103</b>
	IN/EX [4] 12,25/15 x 7 x 36,5	B1				<b>81-33104</b>
					038 109 101 K	<b>50 006 202</b> (1)
	(1) Schalenhartguss/chilled cast iron/pièce moulée trempée en surface/fundición en coquilla/Отливка с отбеленным поверхностным слоем					
	[8] H 35 x 26 x 26				050 109 309 050 109 309 A 050 109 309 H 050 109 309 J	<b>50 006 417</b>
	[8] H 35 x 26 x 26				034 109 309 034 109 309 AC 034 109 309 AD 034 109 309 N 074 109 309	<b>50 006 460</b>

## 152 79,5

**AHH** 10.1996 → 11.2000 D (A) 4 1896 cm<sup>3</sup> 2V 66 kW (90 PS) 19,5 95,50 mm  
94 427 7..., 94 428 7..

	IN [2] 36,0 x 7 x 96,9 EX [2] 31,6 x 7 x 96,9	S - - RA/S- -	- 45° - - - 45° - -	22 - III 22 - III	028 109 601 D 028 109 611 G	<b>39486</b> <b>331143</b>
	[50] Ø 7 mm				021 109 651	<b>MK-7H</b>
	IN/EX [4] 12,08/15 x 7 x 36,5 IN/EX [4] 12,25/15 x 7 x 36,5	B1 B1			037 103 415 037 103 419 B	<b>81-33103</b> <b>81-33104</b>
					028 109 101 F	<b>50 006 205</b> (1)
	(1) Schalenhartguss/chilled cast iron/pièce moulée trempée en surface/fundición en coquilla/Отливка с отбеленным поверхностным слоем					
	[8] H 35 x 26 x 26				034 109 309 034 109 309 AC 034 109 309 AD 034 109 309 N 074 109 309	<b>50 006 460</b>

## 153 79,5

**AKW** 07.1997 → 09.2001 D (NA) 4 1715 cm<sup>3</sup> 2V 42 kW (57 PS) 19,5 86,40 mm

	IN [2] 36,0 x 7 x 96,6 EX [2] 31,5 x 7 x 96,4	S - - RA/S- -	- 45° - - - 45° - VS -	22 - III 22 - III	028 109 601 J 028 109 611 K	<b>39502</b> <b>39503</b>
	[50] Ø 7 mm				021 109 651	<b>MK-7H</b>
	IN/EX [4] 12,08/15 x 7 x 36,5 IN/EX [4] 12,25/15 x 7 x 36,5	B1 B1			037 103 415 037 103 419 B	<b>81-33103</b> <b>81-33104</b>
	[8] H 35 x 26 x 26				034 109 309 034 109 309 AC 034 109 309 AD 034 109 309 N 074 109 309	<b>50 006 460</b>

## 154 79,5

**AJA** 08.1997 → 04.2003 D (NA) 5 2370 cm<sup>3</sup> 2V 55 kW (75 PS) 23,5.1 95,50 mm  
91 386 6..

Fortsetzung nächste Seite / continued on next page / suite page suivante / continuación página próxima / Продолжение на следующей странице

					Reference	Item No.	
	IN [2] EX [2] EX [2]	36,0 x 8 x 95,6 31,2 x 8 x 95,1 31,2 x 8 x 95,6	S - - A/S - - RA/S- Cr -	- 45° - - - 45° - VS - - 45° - VS -	22 - III 22 - III 22 - III	069 109 601 F 074 109 611 074 109 611	<b>39123</b> <b>33049</b> <b>39185</b>
	[50]	Ø 8 mm				113 109 651 A 400 501 068	<b>MK-8H</b>
	IN/EX [4] IN/EX [4] IN/EX [4]	12,06/15 x 8 x 36,5 12,13/15 x 8 x 36,5 12,20/15 x 8 x 36,5	B1 B1 B1			056 103 419 A	<b>81-3310</b> <b>81-3312</b> <b>81-3311</b>
						069 109 101P 074 109 101 B	<b>50 006 216</b> (1)
	(1)	Schalenhartguss/chilled cast iron/pièce moulée trempée en surface/fundición en coquilla/Отливка с отбеленным поверхностным слоем					
	[8]	H 35 x 26 x 26				034 109 309 034 109 309 AC 034 109 309 AD 034 109 309 N 074 109 309	<b>50 006 460</b>
		- - G - S - PC - SB - -				074 103 351 D	<b>50 003 113</b> (2)
	(2)					35 Nm 60 Nm 2 x 90° 90° warm/chaud/caliente	
	(2)	Vorkammerbohrung/prechamber bore/alésage pour la préchambre/alojamiento de la precámara/ Отверстие форкамеры Ø 32 mm / Hydrostößel/hydraulic tappets/poussoirs hydrauliques/ empujadores hidráulicos/Гидротолкатель Zylinderkopfdeckelfläche ohne Bohrungen Without drill holes to fit rocker gasket Sans trous de fixation sur le plan de joint du cache culbuteurs Sin taladros para fijación de junta de balancines Поверхность крышки головки блока цилиндров без отверстий					

**155**
**79,5**
**AGP** 08.1997 → 06.2006 D (NA) 4 1896 cm<sup>3</sup> 2V 50 kW (68 PS) 19,5 95,50 mm  
 40 092 7.., 40 093 7..

	IN [2] IN [2] EX [2] EX [2] EX [2]	36,0 x 7 x 96,6 36,0 x 8 x 95,6 31,2 x 8 x 95,1 31,2 x 8 x 95,6 31,5 x 7 x 96,4	S - - S - - A/S - - RA/S- Cr - RA/S- -	- 45° - - - 45° - - - 45° - VS - - 45° - VS - - 45° - VS -	22 - III 22 - III 22 - III 22 - III 22 - III	028 109 601 J 069 109 601 F 074 109 611 074 109 611 028 109 611 K	<b>39502</b> <b>39123</b> <b>33049</b> <b>39185</b> <b>39503</b>
	[50] [50]	Ø 7 mm Ø 8 mm				021 109 651 113 109 651 A 400 501 068	<b>MK-7H</b> <b>MK-8H</b>
	IN/EX [4] IN/EX [4]	12,06/15 x 8 x 36,5 12,08/15 x 7 x 36,5	B1 B1			056 103 419 A 037 103 415 037 103 419 B	<b>81-3310</b> <b>81-33103</b>
	IN/EX [4] IN/EX [4] IN/EX [4]	12,13/15 x 8 x 36,5 12,20/15 x 8 x 36,5 12,25/15 x 7 x 36,5	B1 B1 B1				<b>81-3312</b> <b>81-3311</b> <b>81-33104</b>
						038 109 101 E	<b>50 006 210</b> (1)
	(1)	Schalenhartguss/chilled cast iron/pièce moulée trempée en surface/fundición en coquilla/Отливка с отбеленным поверхностным слоем					

Fortsetzung nächste Seite / continued on next page / suite page suivante / continuación página próxima / Продолжение на следующей странице

					Reference	Item No.
[8]	H 35 x 26 x 26				050 109 309 050 109 309 A 050 109 309 H 050 109 309 J	<b>50 006 417</b>

**156**

**79,5**

<b>AJM</b>	08.1998 → 04.2002	D (A)	4	1896 cm <sup>3</sup>	2V	85 kW	(115 PS)	18	95,50 mm
<b>ATD</b>	02.2000 →	D (A)	4	1896 cm <sup>3</sup>	2V	74 kW	(101 PS)	19	95,50 mm
<b>ATJ</b>	08.1999 → 11.2000	D (LA)	4	1896 cm <sup>3</sup>	2V	85 kW	(115 PS)	18	95,50 mm
<b>AVB</b>	02.2000 → 05.2005	D (A)	4	1896 cm <sup>3</sup>	2V	74 kW	(101 PS)	19	95,50 mm

99 843 6..., 99 850 6..., 99 851 6..

	IN [2] EX [2]	35,9 x 7 x 89,9 31,5 x 7 x 90,0	S - - A/S - -	- 45° - - - 45° - VS -	22 - III 22 - III	038 109 601 B 038 109 611 B 038 109 611 F	<b>331033</b> <b>331034</b>
	[50]	Ø 7 mm				021 109 651	<b>MK-7H</b>
	IN/EX [4]	12,07 x 7 x 31,5	B1				<b>81-33115</b>
	(1)	Aloy Steel SAE 8620 / (ST)				038 109 101 R	<b>50 006 304</b> (1)
	[8]	H 35 x 26 x 26				038 109 309 A 038 109 309 B 038 109 309 C	<b>50 006 418</b>
	[1]	(2) Kipphebeleinheit - nicht voreingestellt! rocker shaft assembly - not preset! Unité culbuteur - n'est pas pré-réglée! Unidad de balancines: no preajustada! Узел коромысла — без предварительной настройки!				038109527AF	<b>50 007 650</b> (2)
	- - G - S -	- SB - -				038 103 351 D 03G 103 351 C 03G 103 351 D	<b>50 003 131</b>
				 40 Nm 60 Nm - 90° + 60 Nm 90° 90° ready-to-install			<b>50 003 431</b> (3)
	(3)	Nockenwelle/camshaft/arbre à cames/árbol de levas/кулачковый вал OE# 038 109 101R					

**157**

**79,5**

<b>ANU</b>	09.1999 → 03.2010	D (A)	4	1896 cm <sup>3</sup>	2V	66 kW	(90 PS)	18	95,50 mm
<b>ASZ</b>	11.2000 → 03.2010	D (LA)	4	1896 cm <sup>3</sup>	2V	96 kW	(130 PS)	19	95,50 mm
<b>AUY</b>	12.1998 → 03.2010	D (LA)	4	1896 cm <sup>3</sup>	2V	85 kW	(115 PS)	18	95,50 mm
<b>AVF</b>	11.2000 → 05.2005	D (A)	4	1896 cm <sup>3</sup>	2V	96 kW	(130 PS)	19	95,50 mm
<b>AWX</b>	11.2000 → 05.2005	D (A)	4	1896 cm <sup>3</sup>	2V	96 kW	(130 PS)	19	95,50 mm
<b>AXB Euro 3</b>	04.2003 → 11.2009	D (LA)	4	1896 cm <sup>3</sup>	2V	77 kW	(105 PS)	18,5	95,50 mm

99 470 6..., 99 843 6..., 99 850 6..., 99 851 6..

	IN [2] EX [2]	35,9 x 7 x 89,9 31,5 x 7 x 90,0	S - - A/S - -	- 45° - - - 45° - VS -	22 - III 22 - III	038 109 601 B 038 109 611 B 038 109 611 F	<b>331033</b> <b>331034</b>
	[50]	Ø 7 mm				021 109 651	<b>MK-7H</b>
Fortsetzung nächste Seite / continued on next page / suite page suivante / continuación página próxima / Продолжение на следующей странице							

					Reference	Item No.
	IN/EX [4] 12,08/15 x 7 x 36,5	B1			037 103 415 037 103 419 B 027 103 419	<b>81-33103</b> <b>81-33100</b> <b>81-33104</b>
	IN/EX [4] 12,08/15 x 7 x 38,0	B1				
	IN/EX [4] 12,25/15 x 7 x 36,5	B1				
	(1) Alloy Steel SAE 8620 / (ST)				038 109 101 R	<b>50 006 304</b> (1)
	[8] H 35 x 26 x 26				038 109 309 A 038 109 309 B 038 109 309 C	<b>50 006 418</b>
	[1] (2) Kipphebeleinheit - nicht voreingestellt! rocker shaft assembly - not preset! Unité culbuteur - n'est pas pré réglée! Unidad de balancines: no preajustada! Узел коромысла — без предварительной настройки!				038109527AF	<b>50 007 650</b> (2)
	- - G - S - - SB - -				038 103 351 D 03G 103 351 C 03G 103 351 D	<b>50 003 131</b>
	CAM - V - G - S - - SB - -		 40 Nm 60 Nm - 90° + 60 Nm 90° 90° ready-to-install			<b>50 003 431</b> (3)
	(3) Nockenwelle/camshaft/arbre à cames/árbol de levas/кулачковый вал OE# 038 109 101R					

## 158 79,5

AMF 01.1999 → 12.2007 D (A) 3 1422 cm<sup>3</sup> 2V 55 kW (75 PS) 19,5 95,50 mm  
41 158 6.., 41 159 6..

	IN [2] 35,9 x 7 x 89,9	S - -	- 45° - -	22 - III	038 109 601 B	<b>331033</b>
	IN [2] 36,0 x 7 x 89,5	S - -	- 45° - -	22 - III	038 109 601 E	<b>331123</b>
	EX [2] 31,5 x 7 x 89,0	RA/S- -	- 45° - VS -	22 - III	038 109 611 E	<b>331124</b>
	EX [2] 31,5 x 7 x 90,0	A/S - -	- 45° - VS -	22 - III	038 109 611 B 038 109 611 F	<b>331034</b>
	[50] Ø 7 mm				021 109 651	<b>MK-7H</b>
	IN/EX [4] 12,08/15 x 7 x 36,5	B1			037 103 415 037 103 419 B 027 103 419	<b>81-33103</b> <b>81-33100</b> <b>81-33104</b>
	IN/EX [4] 12,08/15 x 7 x 38,0	B1				
	IN/EX [4] 12,25/15 x 7 x 36,5	B1				
					045 109 101 C	<b>50 006 388</b>
	[8] H 35 x 26 x 26				038 109 309 A 038 109 309 B 038 109 309 C	<b>50 006 418</b>

## 159 79,5

ATL 01.2000 → 10.2000 D (LA) 3 1422 cm<sup>3</sup> 2V 66 kW (90 PS) 19,5 95,50 mm

	IN [2] 36,0 x 7 x 89,5	S - -	- 45° - -	22 - III	038 109 601 E	<b>331123</b>
	EX [2] 31,5 x 7 x 89,0	RA/S- -	- 45° - VS -	22 - III	038 109 611 E	<b>331124</b>
	[50] Ø 7 mm				021 109 651	<b>MK-7H</b>

Fortsetzung nächste Seite / continued on next page / suite page suivante / continuación página próxima / Продолжение на следующей странице

					Reference	Item No.
IN/EX [4]	12,08/15 x 7 x 36,5	B1			037 103 415 037 103 419 B	<b>81-33103</b>
IN/EX [4]	12,25/15 x 7 x 36,5	B1				<b>81-33104</b>
[8]	H 35 x 26 x 26				038 109 309 A 038 109 309 B 038 109 309 C	<b>50 006 418</b>

## 160 79,5

**ARL** 02.2000 → 06.2006 D (LA) 4 1896 cm<sup>3</sup> 2V 110 kW (150 PS) 18,5 95,50 mm  
99 470 6..

IN [2] EX [2]	35,9 x 7 x 89,9 31,5 x 7 x 90,0	S - - A/S - -	- 45° - - - 45° - VS -	22 - III 22 - III	038 109 601 B 038 109 611 B 038 109 611 F	<b>331033</b> <b>331034</b>
[50]	Ø 7 mm				021 109 651	<b>MK-7H</b>
IN/EX [4] IN/EX [4] IN/EX [4] IN/EX [4]	12,07 x 7 x 31,5 12,08/15 x 7 x 36,5 12,08/15 x 7 x 38,0 12,25/15 x 7 x 36,5	B1 B1 B1 B1			037 103 415 037 103 419 B 027 103 419	<b>81-33115</b> <small>NEW</small> <b>81-33103</b> <b>81-33100</b> <b>81-33104</b>
	(1) Alloy Steel SAE 8620 / (ST)				038 109 101 R	<b>50 006 304</b> (1)
[8]	H 35 x 26 x 26				038 109 309 A 038 109 309 B 038 109 309 C	<b>50 006 418</b>
[1]	(2) Kipphebeleinheit - nicht voreingestellt! rocker shaft assembly - not preset! Unité culbuteur - n'est pas pré-réglée! Unidad de balancines: no preajustada! Узел коромысла — без предварительной настройки!				038109527AF	<b>50 007 650</b> (2)
	- - G - S - - SB - -				038 103 351 D 03G 103 351 C 03G 103 351 D	<b>50 003 131</b>
				40 Nm 60 Nm - 90° + 60 Nm 90° 90°		
	CAM - V - G - S - - SB - -		ready-to-install			<b>50 003 431</b> (3)
	(3) Nockenwelle/camshaft/arbre à cames/árbol de levas/кулачковый вал OE# 038 109 101R					

## 161 79,5

**AXR** 02.2000 → 09.2010 D (LA) 4 1896 cm<sup>3</sup> 2V 74 kW (101 PS) 19 95,50 mm  
**BKC** 08.2003 → 11.2010 D (LA) 4 1896 cm<sup>3</sup> 2V 77 kW (105 PS) 19 95,50 mm  
**BXE** 08.2003 → 11.2010 D (LA) 4 1896 cm<sup>3</sup> 2V 77 kW (105 PS) 19 95,50 mm

40 421 6.., 40 422 6.., 99 850 6.., 99 851 6..

IN [2] EX [2]	36,0 x 7 x 89,5 31,5 x 7 x 89,0	S - - RA/S- -	- 45° - - - 45° - VS -	22 - III 22 - III	038 109 601 E 038 109 611 E	<b>331123</b> <b>331124</b>
[50]	Ø 7 mm				021 109 651	<b>MK-7H</b>

Fortsetzung nächste Seite / continued on next page / suite page suivante / continuación página próxima / Продолжение на следующей странице



					Reference	Item No.
	IN/EX [4] 12,07 x 7 x 31,5	B1				<b>81-33115</b> <small>NEW</small>
	(1) Alloy Steel SAE 8620 / (ST)				038 109 101 R	<b>50 006 304</b> (1)
	[8] H 35 x 26 x 26				038 109 309 A 038 109 309 B 038 109 309 C	<b>50 006 418</b>
	[1] (2) Kipphebeleinheit - nicht voreingestellt! rocker shaft assembly - not preset! Unité culbuteur - n'est pas pré réglée! Unidad de balancines: no preajustada! Узел коромысла — без предварительной настройки!				038109527AF	<b>50 007 650</b> (2)
	- - G - S - - SB - -				038 103 351 D 03G 103 351 C 03G 103 351 D	<b>50 003 131</b>
					40 Nm 60 Nm - 90° + 60 Nm 90° 90°	
	CAM - V - G - S - - SB - -			ready-to-install		<b>50 003 431</b> (3)
	(3) Nockenwelle/camshaft/arbre à cames/árbol de levas/кулачковый вал OE# 038 109 101R					

**162**
**79,5**
**BVK** 04.2000 → D (LA) 4 1896 cm<sup>3</sup> 2V 85 kW (115 PS) 18 95,50 mm  
 99 843 6..

	IN [2] 35,9 x 7 x 89,9 EX [2] 31,5 x 7 x 90,0	S - - A/S - -	- 45° - - - 45° - VS -	22 - III 22 - III	038 109 601 B 038 109 611 B 038 109 611 F	<b>331033</b> <b>331034</b>
	[50] Ø 7 mm				021 109 651	<b>MK-7H</b>
	IN/EX [4] 12,08/15 x 7 x 36,5	B1			037 103 415 037 103 419 B 027 103 419	<b>81-33103</b> <b>81-33100</b> <b>81-33104</b>
	(1) (ST)				038 109 101 AH	<b>50 006 342</b> (1)
	[1] (2) Kipphebeleinheit - nicht voreingestellt! rocker shaft assembly - not preset! Unité culbuteur - n'est pas pré réglée! Unidad de balancines: no preajustada! Узел коромысла — без предварительной настройки!				038109527AF	<b>50 007 650</b> (2)

Fortsetzung nächste Seite / continued on next page / suite page suivante / continuación página próxima / Продолжение на следующей странице

					Reference	Item No.
	- - G - S -	- SB - -			038 103 351 D 03G 103 351 C 03G 103 351 D	<b>50 003 131</b>
			<p>40 Nm 60 Nm - 90° + 60 Nm 90° 90°</p>			

## 163 79,5

**BEW** 09.2000 → 09.2010 D (LA) 4 1896 cm<sup>3</sup> 2V 74 kW (101 PS) 19 95,50 mm  
99 850 6..., 99 851 6..

	IN [2]	36,0 x 7 x 88,8	S - Cr -	- 50° - -	22 - III	038 109 601F	<b>331147</b>
	[50]	∅ 7 mm				021 109 651	<b>MK-7H</b>
	IN/EX [4]	12,07 x 7 x 31,5	B1				<b>81-33115</b>
	[1]					038109527AF	<b>50 007 650</b> (1)
		(1) Kipphebeleinheit - nicht voreingestellt! rocker shaft assembly - not preset! Unité culbuteur - n'est pas pré réglée! Unidad de balancines: no preajustada! Узел коромысла — без предварительной настройки!					

## 164 79,5

**AVM Euro 3** 11.2000 → D (A) 4 1896 cm<sup>3</sup> 2V 63 kW (86 PS) 19,5:1 95,50 mm  
94 427 7..., 94 428 7..

	IN [2] EX [2]	36,0 x 7 x 96,9 31,6 x 7 x 96,9	S - - RA/S- -	- 45° - - - 45° - -	22 - III 22 - III	028 109 601 D 028 109 611 G	<b>39486</b> <b>331143</b>
	[50]	∅ 7 mm				021 109 651	<b>MK-7H</b>

## 165 79,5

**BMT** 10.2001 → 11.2009 D (LA) 4 1896 cm<sup>3</sup> 2V 74 kW (101 PS) 19:1 95,50 mm  
40 421 6..., 40 422 6..

	IN [2] EX [2]	36,0 x 7 x 89,5 31,5 x 7 x 89,0	S - - RA/S- -	- 45° - - - 45° - VS -	22 - III 22 - III	038 109 601 E 038 109 611 E	<b>331123</b> <b>331124</b>
	[50]	∅ 7 mm				021 109 651	<b>MK-7H</b>
	IN/EX [4]	12,08/15 x 7 x 36,5	B1			037 103 415 037 103 419 B	<b>81-33103</b>
	IN/EX [4]	12,25/15 x 7 x 36,5	B1				<b>81-33104</b>
						038 109 101 AH	<b>50 006 342</b> (1)
	(1) (ST)						
	[8]	H 35 x 26 x 26				038 109 309 A 038 109 309 B 038 109 309 C	<b>50 006 418</b>
	[1]					038109527AF	<b>50 007 650</b> (2)

Fortsetzung nächste Seite / continued on next page / suite page suivante / continuación página próxima / Продолжение на следующей странице

					Reference	Item No.
(2)	Kipphebeleinheit - nicht voreingestellt! rocker shaft assembly - not preset! Unité culbuteur - n'est pas pré réglée! Unidad de balancines: no preajustada! Узел коромысла — без предварительной настройки!					

## 166 79,5

<b>BAY KAT</b>	10.2001 → 06.2005	D (LA)	3	1422 cm <sup>3</sup>	2V	55 kW	(75 PS)	19,5	95,50 mm
<b>BNM</b>	04.2005 → 12.2009	D (LA)	3	1422 cm <sup>3</sup>	2V	51 kW	(70 PS)	19,5	95,50 mm
<b>BNV</b>	04.2005 → 11.2009	D (LA)	3	1422 cm <sup>3</sup>	2V	59 kW	(80 PS)	19,5	95,50 mm

41 158 6.., 41 159 6..

	IN [2] EX [2]	36,0 x 7 x 89,5 31,5 x 7 x 89,0	S - - RA/S- -	- 45° - - - 45° - VS -	22 - III 22 - III	038 109 601 E 038 109 611 E	<b>331123</b> <b>331124</b>
	[50]	Ø 7 mm				021 109 651	<b>MK-7H</b>
	IN/EX [4]	12,08/15 x 7 x 36,5	B1			037 103 415 037 103 419 B	<b>81-33103</b>
	IN/EX [4]	12,25/15 x 7 x 36,5	B1				<b>81-33104</b>
						045 109 101 C	<b>50 006 388</b>
	[8]	H 35 x 26 x 26				038 109 309 A 038 109 309 B 038 109 309 C	<b>50 006 418</b>

## 167 79,5

<b>ANC</b>	02.2003 →	D (NA)	4	1896 cm <sup>3</sup>	2V	44 kW	(60 PS)	22,5:1	95,50 mm
<b>ARD</b>	01.2002 →	D (NA)	4	1896 cm <sup>3</sup>	2V	44 kW	(60 PS)	22,5:1	95,50 mm
<b>BEQ</b>	02.2002 →	D (NA)	4	1896 cm <sup>3</sup>	2V	33 kW	(45 PS)		95,50 mm
<b>BGL</b>	02.2003 →	D (NA)	4	1896 cm <sup>3</sup>	2V	37 kW	(50 PS)	23:1	95,50 mm
<b>BGM Euro 3</b>	02.2003 →	D (NA)	4	1896 cm <sup>3</sup>	2V	29 kW	(40 PS)	23:1	95,50 mm
<b>CDXA</b>	10.2007 →	D (A)	4	1896 cm <sup>3</sup>	2V	55 kW	(75 PS)	23:1	95,50 mm
<b>CDXB</b>	10.2007 →	D (A)	4	1896 cm <sup>3</sup>	2V	29 kW	(40 PS)	23:1	95,50 mm

40 092 7.., 40 093 7.., 94 427 7.., 94 428 7..

	IN [2] EX [2]	36,0 x 7 x 96,6 31,5 x 7 x 96,4	S - - RA/S- -	- 45° - - - 45° - VS -	22 - III 22 - III	028 109 601 J 028 109 611 K	<b>39502</b> <b>39503</b>
	[50]	Ø 7 mm				021 109 651	<b>MK-7H</b>

## 168 79,5

<b>BGG</b>	06.2002 →	D (NA)	4	1896 cm <sup>3</sup>	2V	47 kW	(64 PS)	22,5	95,50 mm
------------	-----------	--------	---	----------------------	----	-------	---------	------	----------

91 386 6..

	IN [2] EX [2]	36,0 x 7 x 95,6 31,0 x 7 x 95,6	S - - A/S - -	- 45° - - - 45° - VS -	22 - III 22 - III	028 109 601 B 028 109 611 E	<b>39395</b> <b>39474</b>
	[50]	Ø 7 mm				021 109 651	<b>MK-7H</b>
	IN/EX [4]	12,08/15 x 7 x 36,5	B1			037 103 415 037 103 419 B	<b>81-33103</b>
	IN/EX [4]	12,25/15 x 7 x 36,5	B1				<b>81-33104</b>
						028 109 101 D 028 109 101 G	<b>50 006 203</b> (1)
(1)	Schalenhartguss/chilled cast iron/pièce moulée trempée en surface/fundición en coquilla/Отливка с отбелсным поверхностным слоем						

					Reference	Item No.	
<b>169</b>		<b>79,5</b>					
<b>AVQ</b>	02.2003 → 05.2005	D (LA)	4	1896 cm <sup>3</sup>	2V	74 kW (100 PS) 19	95,50 mm
<b>BJB</b>	04.2004 → 08.2010	D (LA)	4	1896 cm <sup>3</sup>	2V	77 kW (105 PS) 19	95,50 mm
40 421 6.., 40 422 6.., 99 850 6.., 99 851 6..							
	IN [2] EX [2]	36,0 x 7 x 89,5 31,5 x 7 x 89,0	S - - RA/S- -	- 45° - - - 45° - VS -	22 - III 22 - III	038 109 601 E 038 109 611 E	<b>331123</b> <b>331124</b>
	[50]	∅ 7 mm				021 109 651	<b>MK-7H</b>
	IN/EX [4]	12,08/15 x 7 x 36,5	B1			037 103 415 037 103 419 B	<b>81-33103</b>
	IN/EX [4]	12,25/15 x 7 x 36,5	B1				<b>81-33104</b>
	[8]	H 35 x 26 x 26				038 109 309 A 038 109 309 B 038 109 309 C	<b>50 006 418</b>
	[1]	(1) Kipphebeleinheit - nicht voreingestellt! rocker shaft assembly - not preset! Unité culbuteur - n'est pas pré réglée! Unidad de balancines: no preajustada! Узел коромысла — без предварительной настройки!				038109527AF	<b>50 007 650</b> (1)
		- - G - S -	- SB - -			038 103 351 D 03G 103 351 C 03G 103 351 D	<b>50 003 131</b>
						40 Nm 60 Nm - 90° + 60 Nm 90° 90°	
		CAM - V - G - S -	- SB - -	ready-to-install			<b>50 003 431</b> (2)
		(2) Nockenwelle/camshaft/arbre à cames/árbol de levas/кулачковый вал OE# 038 109 101R					
<b>170</b>		<b>79,5</b>					
<b>AXC Euro 3</b>	04.2003 → 11.2009	D (LA)	4	1896 cm <sup>3</sup>	2V	63 kW (85 PS) 19,5:1	95,50 mm
99 470 6..							
	IN [2] EX [2]	35,9 x 7 x 89,9 31,5 x 7 x 90,0	S - - A/S - -	- 45° - - - 45° - VS -	22 - III 22 - III	038 109 601 B 038 109 611 B 038 109 611 F	<b>331033</b> <b>331034</b>
	[50]	∅ 7 mm				021 109 651	<b>MK-7H</b>
	IN/EX [4]	12,08/15 x 7 x 38,0	B1			027 103 419	<b>81-33100</b>
						038 109 101 R	<b>50 006 304</b> (1)
		(1) Alloy Steel SAE 8620 / (ST)					
	[8]	H 35 x 26 x 26				038 109 309 A 038 109 309 B 038 109 309 C	<b>50 006 418</b>
	[1]					038109527AF	<b>50 007 650</b> (2)
Fortsetzung nächste Seite / continued on next page / suite page suivante / continuación página próxima / Продолжение на следующей странице							

					Reference	Item No.
(2)	Kipphebeleinheit - nicht voreingestellt! rocker shaft assembly - not preset! Unité culbuteur - n'est pas pré réglée! Unidad de balancines: no preajustada! Узел коромысла — без предварительной настройки!					
	- - G - S -	- SB - -			038 103 351 D 03G 103 351 C 03G 103 351 D	<b>50 003 131</b>
				40 Nm 60 Nm - 90° + 60 Nm 90° 90°		
	CAM - V - G - S -	- SB - -	ready-to-install			<b>50 003 431</b> (3)
(3)	Nockenwelle/camshaft/arbre à cames/árbol de levas/кулачковый вал OE# 038 109 101R					

**171**

**79,5**

**BLS** 08.2003 → 11.2010 D (LA) 4 1896 cm<sup>3</sup> 2V 77 kW (105 PS) 19:1 95,50 mm  
40 421 6..., 40 422 6..

	IN [2] EX [2]	36,0 x 7 x 89,5 31,5 x 7 x 89,0	S - - RA/S- -	- 45° - - - 45° - VS -	22 - III 22 - III	038 109 601 E 038 109 611 E	<b>331123</b> <b>331124</b>
	[50]	∅ 7 mm				021 109 651	<b>MK-7H</b>
	IN/EX [4]	12,07 x 7 x 31,5	B1				<b>81-33115</b> <small>NEW</small>
	(1) (ST)					038 109 101 AH	<b>50 006 342</b> (1)
	[8]	H 35 x 26 x 26				038 109 309 A 038 109 309 B 038 109 309 C	<b>50 006 418</b>
	[1]					038109527AF	<b>50 007 650</b> (2)
	(2)	Kipphebeleinheit - nicht voreingestellt! rocker shaft assembly - not preset! Unité culbuteur - n'est pas pré réglée! Unidad de balancines: no preajustada! Узел коромысла — без предварительной настройки!					
	- - G - S -	- SB - -				038 103 351 D 03G 103 351 C 03G 103 351 D	<b>50 003 131</b>
				40 Nm 60 Nm - 90° + 60 Nm 90° 90°			

**172**

**79,5**

**BLT** 05.2004 → 11.2009 D (LA) 4 1896 cm<sup>3</sup> 2V 96 kW (130 PS) 19 95,50 mm  
99 470 6..

	IN [2] EX [2] EX [2] EX [2]	35,9 x 7 x 89,9 36,0 x 7 x 89,5 31,5 x 7 x 89,0 31,5 x 7 x 90,0	S - - S - - RA/S- - A/S - -	- 45° - - - 45° - - - 45° - VS - - 45° - VS -	22 - III 22 - III 22 - III 22 - III	038 109 601 B 038 109 601 E 038 109 611 E 038 109 611 B 038 109 611 F	<b>331033</b> <b>331123</b> <b>331124</b> <b>331034</b>
--	--------------------------------------	--	--------------------------------------	--	--	---	--

Fortsetzung nächste Seite / continued on next page / suite page suivante / continuación página próxima / Продолжение на следующей странице

					Reference	Item No.
[50]	Ø 7 mm				021 109 651	<b>MK-7H</b>
IN/EX [4]	12,08/15 x 7 x 36,5	B1			037 103 415 037 103 419 B	<b>81-33103</b>
IN/EX [4]	12,25/15 x 7 x 36,5	B1				<b>81-33104</b>
	(1) Alloy Steel SAE 8620 / (ST)				038 109 101 R	<b>50 006 304</b> (1)
[1]	(2) Kipphebeleinheit - nicht voreingestellt! rocker shaft assembly - not preset! Unité culbuteur - n'est pas pré réglée! Unidad de balancines: no preajustada! Узел коромысла — без предварительной настройки!				038109527AF	<b>50 007 650</b> (2)
	- - G - S - - SB - -				038 103 351 D 03G 103 351 C 03G 103 351 D	<b>50 003 131</b>
	CAM - V - G - S - - SB - -			<p>40 Nm 60 Nm - 90° + 60 Nm 90° 90°</p>		<b>50 003 431</b> (3)
	(3) Nockenwelle/camshaft/arbre à cames/árbol de levas/кулачковый вал OE# 038 109 101R			ready-to-install		

**173**
**79,5**

**BRU** 05.2004 → 05.2010 D (LA) 4 1896 cm<sup>3</sup> 2V 66 kW (90 PS) 19 95,50 mm  
99 850 6.., 99 851 6..

IN [2] EX [2]	36,0 x 7 x 89,5 31,5 x 7 x 89,0	S - - RA/S- -	- 45° - - - 45° - VS -	22 - III 22 - III	038 109 601 E 038 109 611 E	<b>331123</b> <b>331124</b>
[50]	Ø 7 mm				021 109 651	<b>MK-7H</b>
IN/EX [4]	12,08/15 x 7 x 36,5	B1			037 103 415 037 103 419 B	<b>81-33103</b>
IN/EX [4]	12,25/15 x 7 x 36,5	B1				<b>81-33104</b>
	(1) Alloy Steel SAE 8620 / (ST)				038 109 101 R	<b>50 006 304</b> (1)
[8]	H 35 x 26 x 26				038 109 309 A 038 109 309 B 038 109 309 C	<b>50 006 418</b>
[1]	(2) Kipphebeleinheit - nicht voreingestellt! rocker shaft assembly - not preset! Unité culbuteur - n'est pas pré réglée! Unidad de balancines: no preajustada! Узел коромысла — без предварительной настройки!				038109527AF	<b>50 007 650</b> (2)

Fortsetzung nächste Seite / continued on next page / suite page suivante / continuación página próxima / Продолжение на следующей странице



					Reference	Item No.
	- - G - S -	- SB - -			038 103 351 D 03G 103 351 C 03G 103 351 D	<b>50 003 131</b>
	CAM - V - G - S -	- SB - -	 40 Nm 60 Nm - 90° + 60 Nm 90° 90° ready-to-install			<b>50 003 431</b> (3)
(3) Nockenwelle/camshaft/arbre à cames/árbol de levas/кулачковый вал OE# 038 109 101R						

**174**
**79,5**
**BXF** 05.2004 → 05.2010 D (LA) 4 1896 cm<sup>3</sup> 2V 66 kW (90 PS) 19 95,50 mm  
 40 421 6.., 40 422 6.., 99 850 6.., 99 851 6..

	IN [2] EX [2]	36,0 x 7 x 89,5 31,5 x 7 x 89,0	S - - RA/S- -	- 45° - - - 45° - VS -	22 - III 22 - III	038 109 601 E 038 109 611 E	<b>331123</b> <b>331124</b>
	[50]	∅ 7 mm				021 109 651	<b>MK-7H</b>
	IN/EX [4] IN/EX [4]	12,08/15 x 7 x 36,5 12,25/15 x 7 x 36,5	B1 B1			037 103 415 037 103 419 B	<b>81-33103</b> <b>81-33104</b>
						038 109 101 R	<b>50 006 304</b> (1)
(1) Alloy Steel SAE 8620 / (ST)							
	[1]					038109527AF	<b>50 007 650</b> (2)
(2) Kiphebeleinheit - nicht voreingestellt! rocker shaft assembly - not preset! Unité culbuteur - n'est pas pré réglée! Unidad de balancines: no preajustada! Узел коромысла — без предварительной настройки!							
	- - G - S -	- SB - -				038 103 351 D 03G 103 351 C 03G 103 351 D	<b>50 003 131</b>
	CAM - V - G - S -	- SB - -	 40 Nm 60 Nm - 90° + 60 Nm 90° 90° ready-to-install				<b>50 003 431</b> (3)
(3) Nockenwelle/camshaft/arbre à cames/árbol de levas/кулачковый вал OE# 038 109 101R							

**175**
**79,5**
**BXJ** 05.2004 → 05.2010 D (LA) 4 1896 cm<sup>3</sup> 2V 66 kW (90 PS) 19,5 95,50 mm  
 40 421 6.., 40 422 6.., 99 850 6.., 99 851 6..

	IN [2] EX [2]	36,0 x 7 x 89,5 31,5 x 7 x 89,0	S - - RA/S- -	- 45° - - - 45° - VS -	22 - III 22 - III	038 109 601 E 038 109 611 E	<b>331123</b> <b>331124</b>
	[50]	∅ 7 mm				021 109 651	<b>MK-7H</b>
	IN/EX [4] IN/EX [4]	12,08/15 x 7 x 36,5 12,25/15 x 7 x 36,5	B1 B1			037 103 415 037 103 419 B	<b>81-33103</b> <b>81-33104</b>
Fortsetzung nächste Seite / continued on next page / suite page suivante / continuación página próxima / Продолжение на следующей странице							

					Reference	Item No.
	(1) (ST)				038 109 101 AH	<b>50 006 342</b> (1)
	[1]  (2) Kipphebeleinheit - nicht voreingestellt! rocker shaft assembly - not preset! Unité culbuteur - n'est pas pré réglée! Unidad de balancines: no preajustada! Узел коромысла — без предварительной настройки!				038109527AF	<b>50 007 650</b> (2)

## 176

**79,5**

<b>BMS</b>	04.2005 → 11.2009	D	(LA)	3	1422 cm <sup>3</sup>	2V	59 kW	(80 PS)	19,5	95,50 mm
<b>BWB</b>	04.2005 → 11.2009	D	(LA)	3	1422 cm <sup>3</sup>	2V	51 kW	(70 PS)	19,5	95,50 mm

41 158 6.., 41 159 6..

	IN [2]	36,0 x 7 x 89,5	S - -	- 45° - -	22 - III	038 109 601 E	<b>331123</b>
	EX [2]	31,5 x 7 x 89,0	RA/S- -	- 45° - VS -	22 - III	038 109 611 E	<b>331124</b>
	[50]	Ø 7 mm				021 109 651	<b>MK-7H</b>
	IN/EX [4]	12,08/15 x 7 x 36,5	B1			037 103 415 037 103 419 B	<b>81-33103</b>
	IN/EX [4]	12,25/15 x 7 x 36,5	B1				<b>81-33104</b>
	(1) (ST)					045109101J	<b>50 007 633</b> (1)

## 177

**79,5**

<b>BTB</b>	06.2005 → 03.2010	D	(LA)	4	1896 cm <sup>3</sup>	2V	110 kW	(150 PS)	19:1	95,50 mm
------------	-------------------	---	------	---	----------------------	----	--------	----------	------	----------

	IN [2]	35,9 x 7 x 89,9	S - -	- 45° - -	22 - III	038 109 601 B	<b>331033</b>
	EX [2]	31,5 x 7 x 90,0	A/S - -	- 45° - VS -	22 - III	038 109 611 B 038 109 611 F	<b>331034</b>
	[50]	Ø 7 mm				021 109 651	<b>MK-7H</b>
	IN/EX [4]	12,08/15 x 7 x 36,5	B1			037 103 415 037 103 419 B	<b>81-33103</b>
	IN/EX [4]	12,08/15 x 7 x 38,0	B1			027 103 419	<b>81-33100</b>
	IN/EX [4]	12,25/15 x 7 x 36,5	B1				<b>81-33104</b>
	[8]	H 35 x 26 x 26				038 109 309 A 038 109 309 B 038 109 309 C	<b>50 006 418</b>
	[1]  (1) Kipphebeleinheit - nicht voreingestellt! rocker shaft assembly - not preset! Unité culbuteur - n'est pas pré réglée! Unidad de balancines: no preajustada! Узел коромысла — без предварительной настройки!					038109527AF	<b>50 007 650</b> (1)
	- - G - S -		- SB - -			038 103 351 D 03G 103 351 C 03G 103 351 D	<b>50 003 131</b>
	CAM - V - G - S -		- SB - -		 40 Nm 60 Nm - 90° + 60 Nm 90° 90° ready-to-install		<b>50 003 431</b> (2)

Fortsetzung nächste Seite / continued on next page / suite page suivante / continuación página próxima / Продолжение на следующей странице

					Reference	Item No.
(2) Nockenwelle/camshaft/arbre à cames/árbol de levas/кулачковый вал OE# 038 109 101R						

**178**

**79,5**

**BSW** 07.2005 → 09.2010 D (LA) 4 1896 cm<sup>3</sup> 2V 77 kW (105 PS) 19 95,50 mm  
99 850 6..., 99 851 6..

	IN [2] EX [2]	35,9 x 7 x 89,9 31,5 x 7 x 89,0	S - - RA/S- -	- 45° - - - 45° - VS -	22 - III 22 - III	038 109 601 B 038 109 611 E	<b>331033</b> <b>331124</b>
	[50]	Ø 7 mm				021 109 651	<b>MK-7H</b>
	IN/EX [4]	12,08/15 x 7 x 36,5	B1			037 103 415 037 103 419 B	<b>81-33103</b>
	IN/EX [4]	12,08/15 x 7 x 38,0	B1			027 103 419	<b>81-33100</b>
	IN/EX [4]	12,25/15 x 7 x 36,5	B1				<b>81-33104</b>
	(1)	Aloy Steel SAE 8620 / (ST)				038 109 101 R	<b>50 006 304</b> (1)
	[1]	(2) Kipphebeleinheit - nicht voreingestellt! rocker shaft assembly - not preset! Unité culbuteur - n'est pas pré réglée! Unidad de balancines: no preajustada! Узел коромысла — без предварительной настройки!				038109527AF	<b>50 007 650</b> (2)
		- - G - S - - SB - -				038 103 351 D 03G 103 351 C 03G 103 351 D	<b>50 003 131</b>
		CAM - V - G - S - - SB - -		<p>40 Nm 60 Nm - 90° + 60 Nm 90° 90°</p>			<b>50 003 431</b> (3)
(3) Nockenwelle/camshaft/arbre à cames/árbol de levas/кулачковый вал OE# 038 109 101R							

**179**

**79,5**

**BRM** 08.2005 → 10.2010 D (LA) 4 1896 cm<sup>3</sup> 2V 74 kW (101 PS) 19:1 95,50 mm

	[1]	(1) Kipphebeleinheit - nicht voreingestellt! rocker shaft assembly - not preset! Unité culbuteur - n'est pas pré réglée! Unidad de balancines: no preajustada! Узел коромысла — без предварительной настройки!				038109527AF	<b>50 007 650</b> (1)
--	-----	--	--	--	--	-------------	-----------------------

**180**

**79,5**

**BRR Euro 4** 01.2006 → 11.2009 D (LA) 4 1896 cm<sup>3</sup> 2V 62 kW (84 PS) 19,5:1 95,50 mm  
**BRS Euro 4** 06.2006 → 11.2009 D (LA) 4 1896 cm<sup>3</sup> 2V 75 kW (102 PS) 19:1 95,50 mm  
**BSU** 09.2005 → 08.2010 D (A) 4 1896 cm<sup>3</sup> 2V 55 kW (75 PS) 19,5:1 95,50 mm  
40 421 6..., 40 422 6..

	IN [2] EX [2]	36,0 x 7 x 89,5 31,5 x 7 x 89,0	S - - RA/S- -	- 45° - - - 45° - VS -	22 - III 22 - III	038 109 601 E 038 109 611 E	<b>331123</b> <b>331124</b>
	[50]	Ø 7 mm				021 109 651	<b>MK-7H</b>

Fortsetzung nächste Seite / continued on next page / suite page suivante / continuación página próxima / Продолжение на следующей странице

					Reference	Item No.
	IN/EX [4] 12,08/15 x 7 x 36,5	B1			037 103 415 037 103 419 B	<b>81-33103</b>
	IN/EX [4] 12,25/15 x 7 x 36,5	B1				<b>81-33104</b>
	(1) (ST)				038 109 101 AH	<b>50 006 342</b> (1)
	[1]				038109527AF	<b>50 007 650</b> (2)
	(2) Kipphebeleinheit - nicht voreingestellt! rocker shaft assembly - not preset! Unité culbuteur - n'est pas pré réglée! Unidad de balancines: no preajustada! Узел коромысла — без предварительной настройки!					
	- - G - S -	- SB - -			038 103 351 D 03G 103 351 C 03G 103 351 D	<b>50 003 131</b>
				40 Nm 60 Nm - 90° + 60 Nm 90° 90°		

## 181 79,5

<b>CAYB Euro 5</b>	02.2009 →	D (LA)	4	1598 cm <sup>3</sup>	4V	66 kW	(90 PS)	16,5	80,50 mm
<b>CAYC</b>	02.2009 →	D (LA)	4	1598 cm <sup>3</sup>	4V	77 kW	(105 PS)	16,5	80,50 mm
<b>CAYD</b>	08.2010 →	D (LA)	4	1598 cm <sup>3</sup>	4V	75 kW	(102 PS)	16,5	80,50 mm
<b>CLNA Euro 5</b>	06.2009 →	D (LA)	4	1598 cm <sup>3</sup>	4V	77 kW	(105 PS)	16,5	80,50 mm

41 095 6..

	IN [2]	26,6 x 6 x 99,3	S - -	- 45° - -	22 - III	03L 109 601A 04L 109 601A	<b>331151</b>
	EX [2]	24,5 x 6 x 99,1	A/S - -	- 45° - VS -	22 - III	03L 109 611A 04L 109 611A	<b>331154</b>
	[50]	Ø 6 mm				036 109 651A	<b>MK-6H</b>
	IN/EX [4]	10,06 x 6 x 36,0	B1				<b>81-33116</b>
	IN/EX [4]	10,21 x 6 x 36,0	B1				<b>81-33117</b>
		ES				03L 109 021 03L 109 021 D 03L 109 021 E	<b>50 007 020</b> (1)
		AS				03L 109 022 03L 109 022 D	<b>50 007 022</b> (1)
	(1) Schalenhartguss/chilled cast iron/pièce moulée trempée en surface/fundición en coquilla/Отливка с отбелнным поверхностным слоем						
	[8]	H 12 x 32,5				03L 109 521 03L 109 521 A	<b>50 006 490</b>
	[4]					059 109 417 A 059 109 417 B 059 109 417 C 059 109 417 F 059 109 417 G 059109417J	<b>50 006 171</b>

					Reference	Item No.	
<b>182</b>		<b>79,5</b>					
<b>CAYA</b>	06.2009 →	D (LA)	4	1598 cm <sup>3</sup>	4V	55 kW (75 PS)	80,50 mm
<b>CAYE</b>	08.2010 → 11.2017	D (LA)	4	1598 cm <sup>3</sup>	4V	55 kW (75 PS) 16,5	80,50 mm
<b>CLHA Euro 5</b>	08.2012 →	D (LA)	4	1598 cm <sup>3</sup>	4V	77 kW (105 PS) 16,2	80,50 mm
<b>CLHB Euro 5</b>	04.2013 →	D (LA)	4	1598 cm <sup>3</sup>	4V	66 kW (90 PS) 16,2	80,50 mm
<b>CRKA Euro 6</b>	04.2013 →	D (LA)	4	1598 cm <sup>3</sup>	4V	66 kW (90 PS) 16,2	80,50 mm
<b>CRKB Filter</b>	01.2013 →	D (LA)	4	1598 cm <sup>3</sup>	4V	81 kW (110 PS) 16,2	80,50 mm
41 095 6.., 41 271 6..							
	IN [2]	26,6 x 6 x 99,3	S - -	- 45° - -	22 - III	03L 109 601A 04L 109 601A	<b>331151</b>
	EX [2]	24,5 x 6 x 99,1	A/S - -	- 45° - VS -	22 - III	03L 109 611A 04L 109 611A	<b>331154</b>
	[50]	∅ 6 mm				036 109 651A	<b>MK-6H</b>
	IN/EX [4]	10,06 x 6 x 36,0	B1				<b>81-33116</b>
	IN/EX [4]	10,21 x 6 x 36,0	B1				<b>81-33117</b>
	[8]	H 12 x 32,5				03L 109 521 03L 109 521 A	<b>50 006 490</b>
	[4]					059 109 417 A 059 109 417 B 059 109 417 C 059 109 417 F 059 109 417 G 059109417J	<b>50 006 171</b>
<b>183</b>		<b>79,5</b>					
<b>CFWA</b>	10.2009 →	D (A)	3	1199 cm <sup>3</sup>	4V	55 kW (75 PS) 16,5	80,50 mm
41 095 6..							
	IN [2]	26,6 x 6 x 99,3	S - -	- 45° - -	22 - III	03L 109 601A 04L 109 601A	<b>331151</b>
	EX [2]	24,5 x 6 x 99,1	A/S - -	- 45° - VS -	22 - III	03L 109 611A 04L 109 611A	<b>331154</b>
	[50]	∅ 6 mm				036 109 651A	<b>MK-6H</b>
	IN/EX [4]	10,06 x 6 x 36,0	B1				<b>81-33116</b>
	IN/EX [4]	10,21 x 6 x 36,0	B1				<b>81-33117</b>
	ES AS					03P 109 021 03P 109 022	<b>50 007 675</b> (1) <b>50 007 676</b> (1)
	(1)	Schalenhartguss/chilled cast iron/pièce moulée trempée en surface/fundición en coquilla/Отливка с отбеленным поверхностным слоем					
	[8]	H 12 x 32,5				03L 109 521 03L 109 521 A	<b>50 006 490</b>
	[4]					059 109 417 A 059 109 417 B 059 109 417 C 059 109 417 F 059 109 417 G 059109417J	<b>50 006 171</b>

					Reference	Item No.		
<b>184</b>		<b>79,5</b>						
<b>CUSA Euro 6</b>	03.2014 →	D (LA)	3	1422 cm <sup>3</sup>	4V	55 kW (75 PS)	16,2	95,50 mm
<b>CUSB Euro 6</b>	02.2014 →	D (LA)	3	1422 cm <sup>3</sup>	4V	66 kW (90 PS)	16,2	95,50 mm
<b>CUTA Euro 6</b>	05.2014 →	D (A)	3	1422 cm <sup>3</sup>	4V	77 kW (105 PS)	16,2	95,50 mm
<b>CXXA Euro 6</b>	04.2013 →	D (LA)	4	1598 cm <sup>3</sup>	4V	66 kW (90 PS)	16,2	80,50 mm
<b>CXXB Euro 6</b>	01.2013 →	D (LA)	4	1598 cm <sup>3</sup>	4V	81 kW (110 PS)	16,2	80,50 mm
<b>DCXA Euro 6</b>	08.2014 →	D (A)	4	1598 cm <sup>3</sup>	4V	88 kW (120 PS)		80,50 mm
<b>DGDB Euro 6</b>	05.2016 → 06.2020	D (LA)	4	1598 cm <sup>3</sup>	4V	85 kW (115 PS)	16,2	80,50 mm
41 271 6.., 41 708 6..								
	IN [2]	26,6 x 6 x 99,3	S - -	- 45° - -	22 - III	03L 109 601A 04L 109 601A		<b>331151</b>
	EX [2]	24,5 x 6 x 99,1	A/S - -	- 45° - VS -	22 - III	03L 109 611A 04L 109 611A		<b>331154</b>
	[50]	∅ 6 mm				036 109 651A		<b>MK-6H</b>
	IN/EX [4]	10,06 x 6 x 36,0	B1					<b>81-33116</b>
	IN/EX [4]	10,21 x 6 x 36,0	B1					<b>81-33117</b>
<b>185</b>		<b>79,5</b>						
<b>DBKA Euro 6</b>	01.2013 →	D (LA)	4	1598 cm <sup>3</sup>	4V	81 kW (110 PS)	16,2	80,50 mm
41 708 6..								
	IN [2]	26,6 x 6 x 99,3	S - -	- 45° - -	22 - III	03L 109 601A 04L 109 601A		<b>331151</b>
	IN [2]	28,1 x 6 x 99,3	S - -	- 45° - -	22 - III	03L 109 601 04L 109 601B		<b>331131</b>
	EX [2]	24,5 x 6 x 99,1	A/S - -	- 45° - VS -	22 - III	03L 109 611A 04L 109 611A		<b>331154</b>
	EX [2]	26,0 x 6 x 99,1	RA/S- -	- 45° - VS -	22 - III	03L 109 611 04L 109 611B 04L 109 611C		<b>331132</b>
	[50]	∅ 6 mm				036 109 651A		<b>MK-6H</b>
	IN/EX [4]	10,06 x 6 x 36,0	B1					<b>81-33116</b>
	IN/EX [4]	10,06 x 6 x 42,0	B1					<b>81-33112</b>
	IN/EX [4]	10,21 x 6 x 36,0	B1					<b>81-33117</b>
<b>186</b>		<b>79,5</b>						
<b>DDYA Euro 6</b>	11.2016 →	D (LA)	4	1598 cm <sup>3</sup>	4V	85 kW (115 PS)	16,2	80,50 mm
<b>DDYB Euro 6</b>	04.2013 →	D (LA)	4	1598 cm <sup>3</sup>	4V	66 kW (90 PS)	16,2	80,50 mm
<b>DGDA Euro 6</b>	05.2016 →	D (LA)	4	1598 cm <sup>3</sup>	4V	85 kW (115 PS)	16,2	80,50 mm
<b>DGTE Euro 6</b>	11.2016 →	D (LA)	4	1598 cm <sup>3</sup>	4V	85 kW (115 PS)	16,2	80,50 mm
	IN [2]	26,6 x 6 x 99,3	S - -	- 45° - -	22 - III	03L 109 601A 04L 109 601A		<b>331151</b>
	EX [2]	24,5 x 6 x 99,1	A/S - -	- 45° - VS -	22 - III	03L 109 611A 04L 109 611A		<b>331154</b>
	[50]	∅ 6 mm				036 109 651A		<b>MK-6H</b>
<b>187</b>		<b>79,5</b>						
<b>BJC</b>		D (LA)	4	1896 cm <sup>3</sup>	2V	53 kW (72 PS)	19,5:1	95,50 mm
94 427 7.., 94 428 7..								
	IN [2]	36,0 x 7 x 96,9	S - -	- 45° - -	22 - III	028 109 601 D		<b>39486</b>
	EX [2]	31,6 x 7 x 96,9	RA/S- -	- 45° - -	22 - III	028 109 611G		<b>331143</b>
	[50]	∅ 7 mm				021 109 651		<b>MK-7H</b>
Fortsetzung nächste Seite / continued on next page / suite page suivante / continuación página próxima / Продолжение на следующей странице								





KOLBENSCHMIDT



## VOLKSWAGEN

					Reference	Item No.
	IN/EX [4] 12,08/15 x 7 x 36,5	B1			037 103 415 037 103 419 B	<b>81-33103</b>
	IN/EX [4] 12,25/15 x 7 x 36,5	B1				<b>81-33104</b>
					038 109 101 K	<b>50 006 202</b> (1)
(1) Schalenhartguss/chilled cast iron/pièce moulée trempée en surface/fundición en coquilla/Отливка с отбеленным поверхностным слоем						
<b>188</b>		<b>79,5</b>				
<b>BXT</b>		D (A)	4	1896 cm <sup>3</sup>	2V	30 kW (41 PS) 19:1 95,50 mm
94 427 7... 94 428 7..						
	IN [2] 36,0 x 7 x 96,6	S - -	- 45° - -	22 - III	028 109 601 J	<b>39502</b>
	EX [2] 31,5 x 7 x 96,4	RA/S- -	- 45° - VS -	22 - III	028 109 611 K	<b>39503</b>
	[50] Ø 7 mm				021 109 651	<b>MK-7H</b>
	IN/EX [4] 12,08/15 x 7 x 36,5	B1			037 103 415 037 103 419 B	<b>81-33103</b>
	IN/EX [4] 12,25/15 x 7 x 36,5	B1				<b>81-33104</b>
<b>189</b>		<b>81</b>				
<b>CHGA</b>	03.2009 →	BG (NA)	4	1595 cm <sup>3</sup>	2V	75 kW (102 PS) 77,40 mm
	IN [2] 39,5 x 6 x 94,0	S - -	- 45° - -	22 - III	06B 109 601B 06B 109 601D 06B 109 601H	<b>331057</b>
	EX [2] 32,9 x 6 x 93,9	A/S - -	- 45° - VS -	22 - III	06B 109 611 C 06B 109 611B	<b>331058</b>
	[50] Ø 6 mm				036 109 651A	<b>MK-6H</b>
	IN/EX [4] 12,06 x 5.99 x 36,4	B1				<b>81-33113</b>
	IN/EX [4] 12,08 x 5.98 x 36,5	B1				<b>81-33114</b>
<b>190</b>		<b>81</b>				
<b>PN</b>	08.1986 → 12.1992	B (NA)	4	1595 cm <sup>3</sup>	2V	51 kW (70 PS) 9 77,40 mm
<b>RF</b>	09.1975 →	B (NA)	4	1595 cm <sup>3</sup>	2V	53 kW (72 PS) 9 77,40 mm
93 872 6..						
	EX [2] 33,0 x 8 x 91,2	A/S - -	- 45° - VS -	22 - III	048 109 611 A 053 109 611	<b>33048</b>
	[50] Ø 8 mm				113 109 651 A 400 501 068	<b>MK-8H</b>
	IN/EX [4] 12,06/15 x 8 x 36,5	B1			056 103 419 A	<b>81-3310</b>
	IN/EX [4] 12,07/15.2 x 8 x 42,5	B1			049 103 419	<b>81-3319</b>
	IN/EX [4] 12,13/15 x 8 x 36,5	B1				<b>81-3312</b>
	IN/EX [4] 12,20/15 x 8 x 36,5	B1				<b>81-3311</b>
	IN/EX [4] 12,20/15.2 x 8 x 42,5	B1				<b>81-3320</b>
					026 109 101M	<b>50 006 397</b> (1)
(1) Schalenhartguss/chilled cast iron/pièce moulée trempée en surface/fundición en coquilla/Отливка с отбеленным поверхностным слоем						
	[8] H 35 x 26 x 26				034 109 309 034 109 309 AC 034 109 309 AD 034 109 309 N 074 109 309	<b>50 006 460</b>

V

					Reference	Item No.	
<b>191</b>	<b>81</b>						
<b>DT</b> 93 872 6..	08.1980 → 03.1988	B	(NA)	4	1595 cm <sup>3</sup> 2V	55 kW (75 PS) 9	77,40 mm
	IN [2]	38,0 x 8 x 91,9	S - -	- 45° - VS -	22 - III	035 109 601 J 035 109 601 K	<b>33282</b>
	IN [2]	38,0 x 8 x 98,6	S - -	- 45° - -	22 - III	035 109 601 C 035 109 601 D 035 109 601 F 035 109 603	<b>33022</b>
	IN [2]	40,0 x 8 x 91,4	S - -	- 45° - VS -	22 - III	026 109 601 C 026 109 601 F 026 109 601A	<b>39136</b>
	EX [2]	33,0 x 8 x 91,2	A/S - -	- 45° - VS -	22 - III	048 109 611 A 053 109 611	<b>33048</b>
	EX [2]	33,0 x 8 x 98,5	A/S - Cr -	- 45° - VS -	22 - III	035 109 611 F 035 109 611 H	<b>33023</b>
	[50]	Ø 8 mm				113 109 651 A 400 501 068	<b>MK-8H</b>
	IN/EX [4]	12,06/15 x 8 x 36,5	B1			056 103 419 A	<b>81-3310</b>
	IN/EX [4]	12,07/15.2 x 8 x 42,5	B1			049 103 419	<b>81-3319</b>
	IN/EX [4]	12,13/15 x 8 x 36,5	B1				<b>81-3312</b>
	IN/EX [4]	12,20/15 x 8 x 36,5	B1				<b>81-3311</b>
	IN/EX [4]	12,20/15.2 x 8 x 42,5	B1				<b>81-3320</b>
						026 109 101M	<b>50 006 397</b> (1)
	(1) Schalenhartguss/chilled cast iron/pièce moulée trempée en surface/fundición en coquilla/Отливка с отбелсным поверхностным слоем						
	[8]	H 35 x 26 x 26				034 109 309 034 109 309 AC 034 109 309 AD 034 109 309 N 074 109 309	<b>50 006 460</b>
<b>192</b>	<b>81</b>						
<b>KT</b> 93 928 6..	08.1982 → 12.1989	B	(NA)	4	1781 cm <sup>3</sup> 2V	82 kW (112 PS) 10	86,40 mm
	IN [2]	39,5 x 8 x 91,9	S - Cr -	- 45° - VS -	22 - III	048 109 601 A	<b>33313</b>
	EX [2]	33,0 x 8 x 91,2	A/S - -	- 45° - VS -	22 - III	048 109 611 A 053 109 611	<b>33048</b>
	[50]	Ø 8 mm				113 109 651 A 400 501 068	<b>MK-8H</b>
	IN/EX [4]	12,07/15.2 x 8 x 42,5	B1			049 103 419	<b>81-3319</b>
	IN/EX [4]	12,20/15.2 x 8 x 42,5	B1				<b>81-3320</b>
	[8]	H 35 x 26 x 26				034 109 309 034 109 309 AC 034 109 309 AD 034 109 309 N 074 109 309	<b>50 006 460</b>
	[8]	M 35 x 28,5				056 109 311 A	<b>50 007 621</b>
<b>193</b>	<b>81</b>						
<b>DX</b>	08.1982 → 12.1992	B	(NA)	4	1781 cm <sup>3</sup> 2V	82 kW (112 PS) 10	86,40 mm
<b>EV</b>	08.1983 → 12.1993	B	(NA)	4	1781 cm <sup>3</sup> 2V	82 kW (112 PS) 10	86,40 mm
93 928 6..							
Fortsetzung nächste Seite / continued on next page / suite page suivante / continuación página próxima / Продолжение на следующей странице							

					Reference	Item No.
	IN [2] 40,0 x 8 x 91,4	S - -	- 45° - VS -	22 - III	026 109 601 C 026 109 601 F 026 109 601A	<b>39136</b>
	EX [2] 33,0 x 8 x 91,2	A/S - -	- 45° - VS -	22 - III	048 109 611 A 053 109 611	<b>33048</b>
	EX [2] 33,0 x 8 x 98,5	A/S - Cr -	- 45° - VS -	22 - III	035 109 611 F 035 109 611 H	<b>33023</b>
	[50] Ø 8 mm				113 109 651 A 400 501 068	<b>MK-8H</b>
	IN/EX [4] 12,06/15 x 8 x 36,5	B1			056 103 419 A	<b>81-3310</b>
	IN/EX [4] 12,07/15.2 x 8 x 42,5	B1			049 103 419	<b>81-3319</b>
	IN/EX [4] 12,13/15 x 8 x 36,5	B1				<b>81-3312</b>
	IN/EX [4] 12,20/15 x 8 x 36,5	B1				<b>81-3311</b>
	IN/EX [4] 12,20/15.2 x 8 x 42,5	B1				<b>81-3320</b>
	[8] H 35 x 26 x 26				034 109 309 034 109 309 AC 034 109 309 AD 034 109 309 N 074 109 309	<b>50 006 460</b>
	[8] M 35 x 28,5				056 109 311 A	<b>50 007 621</b>
<b>194</b>	<b>81</b>					
<b>EW</b>	08.1982 → 02.2002	B (NA)	4	1595 cm <sup>3</sup>	2V 55 kW (75 PS)	9 77,40 mm
<b>EZ</b>	08.1983 → 07.1992	B (NA)	4	1595 cm <sup>3</sup>	2V 55 kW (75 PS)	9 77,40 mm
<b>HN</b>	01.1983 → 04.1992	B (NA)	4	1595 cm <sup>3</sup>	2V 53-55 kW (72-75 PS)	9 77,40 mm
93 872 6..						
	IN [2] 38,0 x 8 x 98,6	S - -	- 45° - -	22 - III	035 109 601 C 035 109 601 D 035 109 601 F 035 109 603	<b>33022</b>
	EX [2] 33,0 x 8 x 91,2	A/S - -	- 45° - VS -	22 - III	048 109 611 A 053 109 611	<b>33048</b>
	EX [2] 33,0 x 8 x 98,5	A/S - Cr -	- 45° - VS -	22 - III	035 109 611 F 035 109 611 H	<b>33023</b>
	[50] Ø 8 mm				113 109 651 A 400 501 068	<b>MK-8H</b>
	IN/EX [4] 12,06/15 x 8 x 36,5	B1			056 103 419 A	<b>81-3310</b>
	IN/EX [4] 12,07/15.2 x 8 x 42,5	B1			049 103 419	<b>81-3319</b>
	IN/EX [4] 12,13/15 x 8 x 36,5	B1				<b>81-3312</b>
	IN/EX [4] 12,20/15 x 8 x 36,5	B1				<b>81-3311</b>
	IN/EX [4] 12,20/15.2 x 8 x 42,5	B1				<b>81-3320</b>
					026 109 101M	<b>50 006 397</b> (1)
	(1) Schalenhartguss/chilled cast iron/pièce moulée trempée en surface/fundición en coquilla/Отливка с отбелсным поверхностным слоем					
	[8] H 35 x 26 x 26				034 109 309 034 109 309 AC 034 109 309 AD 034 109 309 N 074 109 309	<b>50 006 460</b>
	[8] M 35 x 28,5				056 109 311 A	<b>50 007 621</b>
<b>195</b>	<b>81</b>					
<b>JH</b>	09.1982 → 12.1992	B (NA)	4	1781 cm <sup>3</sup>	2V 66-75 kW (90-102 PS)	10 86,40 mm
93 928 6..						
	IN/EX [4] 12,07/15.2 x 8 x 42,5	B1			049 103 419	<b>81-3319</b>
	IN/EX [4] 12,20/15.2 x 8 x 42,5	B1				<b>81-3320</b>
Fortsetzung nächste Seite / continued on next page / suite page suivante / continuación página próxima / Продолжение на следующей странице						

					Reference	Item No.
[8]	H 35 x 26 x 26				034 109 309 034 109 309 AC 034 109 309 AD 034 109 309 N 074 109 309	<b>50 006 460</b>
[8]	M 35 x 28,5				056 109 311 A	<b>50 007 621</b>

## 196

### 81

<b>DS</b>	01.1983 → 06.1989	B (NA)	4	1781 cm <sup>3</sup>	2V	66 kW	(90 PS)	9	86,40 mm
<b>JN</b>	08.1983 → 07.1994	B (NA)	4	1781 cm <sup>3</sup>	2V	66-76 kW	(90-103 PS)	10	86,40 mm
<b>JV</b>	01.1983 → 12.1999	B (NA)	4	1781 cm <sup>3</sup>	2V	66 kW	(90 PS)	9	86,40 mm

93 928 6..

	IN [2]	38,0 x 8 x 91,9	S - -	- 45° - VS -	22 - III	035 109 601 J 035 109 601 K	<b>33282</b>
	IN [2]	38,0 x 8 x 98,6	S - -	- 45° - -	22 - III	035 109 601 C 035 109 601 D 035 109 601 F 035 109 603	<b>33022</b>
	IN [2]	40,0 x 8 x 91,4	S - -	- 45° - VS -	22 - III	026 109 601 C 026 109 601 F 026 109 601A	<b>39136</b>
	EX [2]	33,0 x 8 x 91,2	A/S - -	- 45° - VS -	22 - III	048 109 611 A 053 109 611	<b>33048</b>
	EX [2]	33,0 x 8 x 98,5	A/S - Cr -	- 45° - VS -	22 - III	035 109 611 F 035 109 611 H	<b>33023</b>
	[50]	∅ 8 mm				113 109 651 A 400 501 068	<b>MK-8H</b>
	IN/EX [4]	12,06/15 x 8 x 36,5	B1			056 103 419 A	<b>81-3310</b>
	IN/EX [4]	12,07/15.2 x 8 x 42,5	B1			049 103 419	<b>81-3319</b>
	IN/EX [4]	12,13/15 x 8 x 36,5	B1				<b>81-3312</b>
	IN/EX [4]	12,20/15 x 8 x 36,5	B1				<b>81-3311</b>
	IN/EX [4]	12,20/15.2 x 8 x 42,5	B1				<b>81-3320</b>
						026109101Q	<b>50 007 594</b> (1)
							(1) Schalenhartguss/chilled cast iron/pièce moulée trempée en surface/fundición en coquilla/Отливка с отбелнным поверхностным слоем
[8]	H 35 x 26 x 26					034 109 309 034 109 309 AC 034 109 309 AD 034 109 309 N 074 109 309	<b>50 006 460</b>

V

## 197

### 81

<b>HP</b>	08.1983 → 03.1988	B (NA)	5	1994 cm <sup>3</sup>	2V	85 kW	(115 PS)	10	77,40 mm
<b>JS</b>	08.1983 → 03.1988	B (NA)	5	1994 cm <sup>3</sup>	2V	85 kW	(115 PS)	10	77,40 mm
<b>KV</b>	01.1985 → 03.1988	B (NA)	5	2226 cm <sup>3</sup>	2V	100 kW	(136 PS)	10	86,40 mm

	IN [2]	38,0 x 8 x 91,9	S - -	- 45° - VS -	22 - III	035 109 601 J 035 109 601 K	<b>33282</b>
	IN [2]	38,0 x 8 x 98,6	S - -	- 45° - -	22 - III	035 109 601 C 035 109 601 D 035 109 601 F 035 109 603	<b>33022</b>
	IN [2]	40,0 x 8 x 91,4	S - -	- 45° - VS -	22 - III	026 109 601 C 026 109 601 F 026 109 601A	<b>39136</b>
	EX [2]	33,0 x 8 x 91,2	A/S - -	- 45° - VS -	22 - III	048 109 611 A 053 109 611	<b>33048</b>
	EX [2]	33,0 x 8 x 98,5	A/S - Cr -	- 45° - VS -	22 - III	035 109 611 F 035 109 611 H	<b>33023</b>

Fortsetzung nächste Seite / continued on next page / suite page suivante / continuación página próxima / Продолжение на следующей странице

					Reference	Item No.
[50]	Ø 8 mm				113 109 651 A 400 501 068	<b>MK-8H</b>
IN/EX [4]	12,06/15 x 8 x 36,5	B1			056 103 419 A	<b>81-3310</b>
IN/EX [4]	12,07/15.2 x 8 x 42,5	B1			049 103 419	<b>81-3319</b>
IN/EX [4]	12,13/15 x 8 x 36,5	B1				<b>81-3312</b>
IN/EX [4]	12,20/15 x 8 x 36,5	B1				<b>81-3311</b>
IN/EX [4]	12,20/15.2 x 8 x 42,5	B1				<b>81-3320</b>
[8]	H 35 x 26 x 26				034 109 309 034 109 309 AC 034 109 309 AD 034 109 309 N 074 109 309	<b>50 006 460</b>

**198**
**81**
**GZ** 08.1983 → 10.1991 B (NA) 4 1781 cm<sup>3</sup> 2V 82 kW (112 PS) 10 86,40 mm  
93 928 6..

IN/EX [4]	12,06/15 x 8 x 36,5	B1			056 103 419 A	<b>81-3310</b>
IN/EX [4]	12,13/15 x 8 x 36,5	B1				<b>81-3312</b>
IN/EX [4]	12,20/15 x 8 x 36,5	B1				<b>81-3311</b>
[8]	H 35 x 26 x 26				034 109 309 034 109 309 AC 034 109 309 AD 034 109 309 N 074 109 309	<b>50 006 460</b>
[8]	M 35 x 28,5				056 109 311 A	<b>50 007 621</b>

**199**
**81**
**ABN** 08.1983 → 07.1992 B (NA) 4 1595 cm<sup>3</sup> 2V 54-55 kW (73-75 PS) 9,1 77,40 mm  
93 872 6..

IN [2]	38,0 x 8 x 91,9	S - -	- 45° - VS -	22 - III	035 109 601 J 035 109 601 K	<b>33282</b>
EX [2]	33,0 x 8 x 91,2	A/S - -	- 45° - VS -	22 - III	048 109 611 A 053 109 611	<b>33048</b>
[50]	Ø 8 mm				113 109 651 A 400 501 068	<b>MK-8H</b>
IN/EX [4]	12,06/15 x 8 x 36,5	B1			056 103 419 A	<b>81-3310</b>
IN/EX [4]	12,13/15 x 8 x 36,5	B1				<b>81-3312</b>
IN/EX [4]	12,20/15 x 8 x 36,5	B1				<b>81-3311</b>
					026 109 101M	<b>50 006 397 (1)</b>

(1) Schalenhartguss/chilled cast iron/pièce moulée trempée en surface/fundición en coquilla/Отливка с отбелсным поверхностным слоем

**200**
**81**
**EX** 08.1983 → 09.1992 B (NA) 4 1781 cm<sup>3</sup> 2V 66 kW (90 PS) 9 86,40 mm  
**GU** B (NA) 4 1781 cm<sup>3</sup> 2V 66 kW (90 PS) 10 86,40 mm  
 93 928 6..

IN [2]	38,0 x 8 x 91,9	S - -	- 45° - VS -	22 - III	035 109 601 J 035 109 601 K	<b>33282</b>
IN [2]	38,0 x 8 x 98,6	S - -	- 45° - -	22 - III	035 109 601 C 035 109 601 D 035 109 601 F 035 109 603	<b>33022</b>
EX [2]	33,0 x 8 x 91,2	A/S - -	- 45° - VS -	22 - III	048 109 611 A 053 109 611	<b>33048</b>
EX [2]	33,0 x 8 x 98,5	A/S - Cr -	- 45° - VS -	22 - III	035 109 611 F 035 109 611 H	<b>33023</b>

Fortsetzung nächste Seite / continued on next page / suite page suivante / continuación página próxima / Продолжение на следующей странице

					Reference	Item No.
[50]	Ø 8 mm				113 109 651 A 400 501 068	<b>MK-8H</b>
IN/EX [4]	12,06/15 x 8 x 36,5	B1			056 103 419 A	<b>81-3310</b>
IN/EX [4]	12,07/15.2 x 8 x 42,5	B1			049 103 419	<b>81-3319</b>
IN/EX [4]	12,13/15 x 8 x 36,5	B1				<b>81-3312</b>
IN/EX [4]	12,20/15 x 8 x 36,5	B1				<b>81-3311</b>
IN/EX [4]	12,20/15.2 x 8 x 42,5	B1				<b>81-3320</b>
	(1) Schalenhartguss/chilled cast iron/pièce moulée trempée en surface/fundición en coquilla/Отливка с отбелнным поверхностным слоем				026109101Q	<b>50 007 594</b> (1)
[8]	H 35 x 26 x 26				034 109 309 034 109 309 AC 034 109 309 AD 034 109 309 N 074 109 309	<b>50 006 460</b>
[8]	M 35 x 28,5				056 109 311 A	<b>50 007 621</b>

## 201

### 81

DZ 12.1983→03.1988 B (NA) 4 1781 cm<sup>3</sup> 2V 82 kW (112 PS) 10 86,40 mm  
93 928 6..

IN [2]	38,0 x 8 x 91,9	S - -	- 45° - VS -	22 - III	035 109 601 J 035 109 601 K	<b>33282</b>
IN [2]	38,0 x 8 x 98,6	S - -	- 45° - -	22 - III	035 109 601 C 035 109 601 D 035 109 601 F 035 109 603	<b>33022</b>
IN [2]	40,0 x 8 x 91,4	S - -	- 45° - VS -	22 - III	026 109 601 C 026 109 601 F 026 109 601A	<b>39136</b>
EX [2]	33,0 x 8 x 91,2	A/S - -	- 45° - VS -	22 - III	048 109 611 A 053 109 611	<b>33048</b>
[50]	Ø 8 mm				113 109 651 A 400 501 068	<b>MK-8H</b>
IN/EX [4]	12,06/15 x 8 x 36,5	B1			056 103 419 A	<b>81-3310</b>
IN/EX [4]	12,07/15.2 x 8 x 42,5	B1			049 103 419	<b>81-3319</b>
IN/EX [4]	12,13/15 x 8 x 36,5	B1				<b>81-3312</b>
IN/EX [4]	12,20/15 x 8 x 36,5	B1				<b>81-3311</b>
IN/EX [4]	12,20/15.2 x 8 x 42,5	B1				<b>81-3320</b>
[8]	H 35 x 26 x 26				034 109 309 034 109 309 AC 034 109 309 AD 034 109 309 N 074 109 309	<b>50 006 460</b>

## 202

### 81

RM 05.1984→12.1995 B (NA) 4 1781 cm<sup>3</sup> 2V 63-64 kW (87 PS) 10 86,40 mm

IN [2]	38,0 x 8 x 91,9	S - -	- 45° - VS -	22 - III	035 109 601 J 035 109 601 K	<b>33282</b>
EX [2]	33,0 x 8 x 91,2	A/S - -	- 45° - VS -	22 - III	048 109 611 A 053 109 611	<b>33048</b>
[50]	Ø 8 mm				113 109 651 A 400 501 068	<b>MK-8H</b>
IN/EX [4]	12,06/15 x 8 x 36,5	B1			056 103 419 A	<b>81-3310</b>
IN/EX [4]	12,13/15 x 8 x 36,5	B1				<b>81-3312</b>
IN/EX [4]	12,20/15 x 8 x 36,5	B1				<b>81-3311</b>

Fortsetzung nächste Seite / continued on next page / suite page suivante / continuación página próxima / Продолжение на следующей странице



					Reference	Item No.	
					026 109 101M 026109101Q	<b>50 006 397</b> (1) <b>50 007 594</b> (1)	
	(1) Schalenhartguss/chilled cast iron/pièce moulée trempée en surface/fundición en coquilla/Отливка с отбеленным поверхностным слоем						
	[8]	H 35 x 26 x 26			034 109 309 034 109 309 AC 034 109 309 AD 034 109 309 N 074 109 309	<b>50 006 460</b>	
<b>203</b>		<b>81</b>	<b>HV</b> 08.1984 → 05.1987 B (NA) 4 1781 cm <sup>3</sup> 2V 66 kW (90 PS) 9 86,40 mm 93 928 6..				
	IN [2]	38,0 x 8 x 98,6	S - -	- 45° - -	22 - III	035 109 601 C 035 109 601 D 035 109 601 F 035 109 603	<b>33022</b>
	EX [2]	33,0 x 8 x 98,5	A/S - Cr -	- 45° - VS -	22 - III	035 109 611 F 035 109 611 H	<b>33023</b>
	[50]	∅ 8 mm				113 109 651 A 400 501 068	<b>MK-8H</b>
	IN/EX [4]	12,06/15 x 8 x 36,5	B1			056 103 419 A	<b>81-3310</b>
	IN/EX [4]	12,13/15 x 8 x 36,5	B1				<b>81-3312</b>
	IN/EX [4]	12,20/15 x 8 x 36,5	B1				<b>81-3311</b>
						026109101Q	<b>50 007 594</b> (1)
	(1) Schalenhartguss/chilled cast iron/pièce moulée trempée en surface/fundición en coquilla/Отливка с отбеленным поверхностным слоем						
	[8]	H 35 x 26 x 26				034 109 309 034 109 309 AC 034 109 309 AD 034 109 309 N 074 109 309	<b>50 006 460</b>
	[8]	M 35 x 28,5				056 109 311 A	<b>50 007 621</b>
<b>204</b>		<b>81</b>	<b>GX</b> 08.1984 → 10.1991 B (NA) 4 1781 cm <sup>3</sup> 2V 66 kW (90 PS) 10 86,40 mm 93 928 6..				
	IN [2]	38,0 x 8 x 98,6	S - -	- 45° - -	22 - III	035 109 601 C 035 109 601 D 035 109 601 F 035 109 603	<b>33022</b>
	EX [2]	33,0 x 8 x 91,2	A/S - -	- 45° - VS -	22 - III	048 109 611 A 053 109 611	<b>33048</b>
	EX [2]	33,0 x 8 x 98,5	A/S - Cr -	- 45° - VS -	22 - III	035 109 611 F 035 109 611 H	<b>33023</b>
	[50]	∅ 8 mm				113 109 651 A 400 501 068	<b>MK-8H</b>
	IN/EX [4]	12,06/15 x 8 x 36,5	B1			056 103 419 A	<b>81-3310</b>
	IN/EX [4]	12,07/15.2 x 8 x 42,5	B1			049 103 419	<b>81-3319</b>
	IN/EX [4]	12,13/15 x 8 x 36,5	B1				<b>81-3312</b>
	IN/EX [4]	12,20/15 x 8 x 36,5	B1				<b>81-3311</b>
	IN/EX [4]	12,20/15.2 x 8 x 42,5	B1				<b>81-3320</b>
Fortsetzung nächste Seite / continued on next page / suite page suivante / continuación página próxima / Продолжение на следующей странице							

V

					Reference	Item No.
[8]	H 35 x 26 x 26				034 109 309 034 109 309 AC 034 109 309 AD 034 109 309 N 074 109 309	<b>50 006 460</b>

## 205



<b>HY</b>	08.1984 → 07.1988	B (NA)	5	2226 cm <sup>3</sup>	2V	100 kW	(136 PS)	9,3	86,40 mm
<b>PB</b>	01.1987 →	B (NA)	4	1781 cm <sup>3</sup>	2V	82 kW	(112 PS)	10	86,40 mm
<b>PF</b>	01.1987 →	B (NA)	4	1781 cm <sup>3</sup>	2V	75-79 kW	(102-107 PS)	10	86,40 mm
<b>RV</b>	01.1985 →	B (NA)	4	1781 cm <sup>3</sup>	2V	75-77 kW	(102-105 PS)	10	86,40 mm

93 928 6..

IN [2]	40,0 x 8 x 91,4	S - -	- 45° - VS -	22 - III	026 109 601 C 026 109 601 F 026 109 601A	<b>39136</b>
EX [2]	33,0 x 8 x 91,2	A/S - -	- 45° - VS -	22 - III	048 109 611 A 053 109 611	<b>33048</b>
[50]	∅ 8 mm				113 109 651 A 400 501 068	<b>MK-8H</b>
IN/EX [4]	12,06/15 x 8 x 36,5	B1			056 103 419 A	<b>81-3310</b>
IN/EX [4]	12,07/15.2 x 8 x 42,5	B1			049 103 419	<b>81-3319</b>
IN/EX [4]	12,13/15 x 8 x 36,5	B1				<b>81-3312</b>
IN/EX [4]	12,20/15 x 8 x 36,5	B1				<b>81-3311</b>
IN/EX [4]	12,20/15.2 x 8 x 42,5	B1				<b>81-3320</b>
[8]	H 35 x 26 x 26				034 109 309 034 109 309 AC 034 109 309 AD 034 109 309 N 074 109 309	<b>50 006 460</b>

## 206



<b>KX</b>	09.1984 → 12.1988	B (NA)	5	2226 cm <sup>3</sup>	2V	82-88 kW	(112-120 PS)	8,5	86,40 mm
-----------	-------------------	--------	---	----------------------	----	----------	--------------	-----	----------

IN [2]	38,0 x 8 x 91,9	S - -	- 45° - VS -	22 - III	035 109 601 J 035 109 601 K	<b>33282</b>
EX [2]	33,0 x 8 x 91,2	A/S - -	- 45° - VS -	22 - III	048 109 611 A 053 109 611	<b>33048</b>
IN/EX [4]	12,06/15 x 8 x 36,5	B1			056 103 419 A	<b>81-3310</b>
IN/EX [4]	12,07/15.2 x 8 x 42,5	B1			049 103 419	<b>81-3319</b>
IN/EX [4]	12,13/15 x 8 x 36,5	B1				<b>81-3312</b>
IN/EX [4]	12,20/15 x 8 x 36,5	B1				<b>81-3311</b>
IN/EX [4]	12,20/15.2 x 8 x 42,5	B1				<b>81-3320</b>
[8]	H 35 x 26 x 26				034 109 309 034 109 309 AC 034 109 309 AD 034 109 309 N 074 109 309	<b>50 006 460</b>

## 207



<b>DTA</b>	08.1986 → 03.1988	B (NA)	4	1595 cm <sup>3</sup>	2V	51-55 kW	(69-75 PS)	9:1	77,40 mm
<b>RL</b>	01.1985 → 03.1988	B (NA)	4	1595 cm <sup>3</sup>	2V	53 kW	(72 PS)	9	77,40 mm

93 872 6..

EX [2]	33,0 x 8 x 91,2	A/S - -	- 45° - VS -	22 - III	048 109 611 A 053 109 611	<b>33048</b>
[50]	∅ 8 mm				113 109 651 A 400 501 068	<b>MK-8H</b>
IN/EX [4]	12,06/15 x 8 x 36,5	B1			056 103 419 A	<b>81-3310</b>
IN/EX [4]	12,13/15 x 8 x 36,5	B1				<b>81-3312</b>
IN/EX [4]	12,20/15 x 8 x 36,5	B1				<b>81-3311</b>

Fortsetzung nächste Seite / continued on next page / suite page suivante / continuación página próxima / Продолжение на следующей странице

					Reference	Item No.	
					026 109 101M	<b>50 006 397</b> (1)	
	(1) Schalenhartguss/chilled cast iron/pièce moulée trempée en surface/fundición en coquilla/Отливка с отбеленным поверхностным слоем						
	[8]	H 35 x 26 x 26			034 109 309 034 109 309 AC 034 109 309 AD 034 109 309 N 074 109 309	<b>50 006 460</b>	
<b>208</b>		<b>81</b>					
<b>HT</b>	01.1985 → 12.1992	B (NA)	4	1781 cm <sup>3</sup>	2V 74-77 kW (100-104 PS)	10 86,40 mm	
93 928 6..							
	IN [2] EX [2]	39,5 x 8 x 91,9 33,0 x 8 x 91,2	S - Cr - A/S - -	- 45° - VS - - 45° - VS -	22 - III 22 - III	048 109 601 A 048 109 611 A 053 109 611	<b>33313</b> <b>33048</b>
	[50]	Ø 8 mm				113 109 651 A 400 501 068	<b>MK-8H</b>
	[8]	H 35 x 26 x 26				034 109 309 034 109 309 AC 034 109 309 AD 034 109 309 N 074 109 309	<b>50 006 460</b>
<b>209</b>		<b>81</b>					
<b>RD</b>	08.1985 → 10.1987	B (NA)	4	1781 cm <sup>3</sup>	2V 79 kW (107 PS)	10 86,40 mm	
	IN [2] EX [2]	40,0 x 8 x 91,4 33,0 x 8 x 91,2	S - - A/S - -	- 45° - VS - - 45° - VS -	22 - III 22 - III	026 109 601 C 026 109 601 F 026 109 601A 048 109 611 A 053 109 611	<b>39136</b> <b>33048</b>
	[50]	Ø 8 mm				113 109 651 A 400 501 068	<b>MK-8H</b>
	IN/EX [4] IN/EX [4] IN/EX [4]	12,06/15 x 8 x 36,5 12,13/15 x 8 x 36,5 12,20/15 x 8 x 36,5	B1 B1 B1			056 103 419 A	<b>81-3310</b> <b>81-3312</b> <b>81-3311</b>
	[8]	H 35 x 26 x 26				034 109 309 034 109 309 AC 034 109 309 AD 034 109 309 N 074 109 309	<b>50 006 460</b>
<b>210</b>		<b>81</b>					
<b>JT</b>	08.1985 → 07.1988	B (NA)	5	2226 cm <sup>3</sup>	2V 82-88 kW (112-120 PS)	8,5 86,40 mm	
	IN [2] EX [2]	38,0 x 8 x 91,9 33,0 x 8 x 91,2	S - - A/S - -	- 45° - VS - - 45° - VS -	22 - III 22 - III	035 109 601 J 035 109 601 K 048 109 611 A 053 109 611	<b>33282</b> <b>33048</b>
	[50]	Ø 8 mm				113 109 651 A 400 501 068	<b>MK-8H</b>
	IN/EX [4] IN/EX [4] IN/EX [4] IN/EX [4] IN/EX [4]	12,06/15 x 8 x 36,5 12,07/15.2 x 8 x 42,5 12,13/15 x 8 x 36,5 12,20/15 x 8 x 36,5 12,20/15.2 x 8 x 42,5	B1 B1 B1 B1 B1			056 103 419 A 049 103 419	<b>81-3310</b> <b>81-3319</b> <b>81-3312</b> <b>81-3311</b> <b>81-3320</b>
Fortsetzung nächste Seite / continued on next page / suite page suivante / continuación página próxima / Продолжение на следующей странице							

V

					Reference	Item No.
[8]	H 35 x 26 x 26				034 109 309 034 109 309 AC 034 109 309 AD 034 109 309 N 074 109 309	<b>50 006 460</b>

## 211

**KR** 10.1985 → 09.1993 B (NA) 4 1781 cm<sup>3</sup> 4V 100-102 kW (136-140 PS) 10 86,40 mm  
**PL** 09.1985 → 07.1992 B (NA) 4 1781 cm<sup>3</sup> 4V 92-95 kW (125-129 PS) 10 86,40 mm

93 117 6..

IN [2] EX [2]	32,0 x 7 x 95,5 28,0 x 7 x 98,2	S - - A/S - Cr -	- 45° - VS - - 45° - VS -	9 - III 9 - III	027 109 601 C 027 109 611 A 027 109 611 B 027 109 611 C 027 109 611 D	<b>33125</b> <b>33050</b>
[50]	∅ 7 mm				027 109 651	<b>RK-7H</b>
IN/EX [4] IN/EX [4]	12,05 x 7 x 38,0 12,15 x 7 x 38,0	B1 B1			027 103 415	<b>81-3321</b> <b>81-3322</b>
[8]	H 35 x 26 x 26				034 109 309 034 109 309 AC 034 109 309 AD 034 109 309 N 074 109 309	<b>50 006 460</b>

## 212

**RE** 04.1986 → 07.1990 B (NA) 4 1595 cm<sup>3</sup> 2V 53 kW (72 PS) 9:1 77,40 mm

93 872 6..

EX [2]	33,0 x 8 x 91,2	A/S - -	- 45° - VS -	22 - III	048 109 611 A 053 109 611	<b>33048</b>
[50]	∅ 8 mm				113 109 651 A 400 501 068	<b>MK-8H</b>
IN/EX [4] IN/EX [4] IN/EX [4] IN/EX [4] IN/EX [4]	12,06/15 x 8 x 36,5 12,07/15.2 x 8 x 42,5 12,13/15 x 8 x 36,5 12,20/15 x 8 x 36,5 12,20/15.2 x 8 x 42,5	B1 B1 B1 B1 B1			056 103 419 A 049 103 419	<b>81-3310</b> <b>81-3319</b> <b>81-3312</b> <b>81-3311</b> <b>81-3320</b>
[8]	H 35 x 26 x 26				034 109 309 034 109 309 AC 034 109 309 AD 034 109 309 N 074 109 309	<b>50 006 460</b>

## 213

**PP** 08.1986 → 03.1988 B (NA) 4 1595 cm<sup>3</sup> 2V 51 kW (70 PS) 8,1 77,40 mm

93 872 6..

IN [2] EX [2]	38,0 x 8 x 91,9 33,0 x 8 x 91,2	S - - A/S - -	- 45° - VS - - 45° - VS -	22 - III 22 - III	035 109 601 J 035 109 601 K 048 109 611 A 053 109 611	<b>33282</b> <b>33048</b>
[50]	∅ 8 mm				113 109 651 A 400 501 068	<b>MK-8H</b>
IN/EX [4] IN/EX [4] IN/EX [4] IN/EX [4] IN/EX [4]	12,06/15 x 8 x 36,5 12,07/15.2 x 8 x 42,5 12,13/15 x 8 x 36,5 12,20/15 x 8 x 36,5 12,20/15.2 x 8 x 42,5	B1 B1 B1 B1 B1			056 103 419 A 049 103 419	<b>81-3310</b> <b>81-3319</b> <b>81-3312</b> <b>81-3311</b> <b>81-3320</b>

Fortsetzung nächste Seite / continued on next page / suite page suivante / continuación página próxima / Продолжение на следующей странице

					Reference	Item No.	
					026 109 101M	<b>50 006 397</b> (1)	
(1) Schalenhartguss/chilled cast iron/pièce moulée trempée en surface/fundición en coquilla/Отливка с отбеленным поверхностным слоем							
<b>214</b>		<b>81</b>					
<b>EZA</b> 93 872 6..	08.1986 → 07.1991	B (NA) 4	1595 cm <sup>3</sup> 2V	51-55 kW (70-75 PS) 9	77,40 mm		
	IN [2]	38,0 x 8 x 98,6	S - -	- 45° - -	22 - III	035 109 601 C 035 109 601 D 035 109 601 F 035 109 603	<b>33022</b>
	EX [2]	33,0 x 8 x 91,2	A/S - -	- 45° - VS -	22 - III	048 109 611 A 053 109 611	<b>33048</b>
	EX [2]	33,0 x 8 x 98,5	A/S - Cr -	- 45° - VS -	22 - III	035 109 611 F 035 109 611 H	<b>33023</b>
	[50]	∅ 8 mm				113 109 651 A 400 501 068	<b>MK-8H</b>
	IN/EX [4]	12,06/15 x 8 x 36,5	B1			056 103 419 A	<b>81-3310</b>
	IN/EX [4]	12,07/15.2 x 8 x 42,5	B1			049 103 419	<b>81-3319</b>
	IN/EX [4]	12,13/15 x 8 x 36,5	B1				<b>81-3312</b>
	IN/EX [4]	12,20/15 x 8 x 36,5	B1				<b>81-3311</b>
	IN/EX [4]	12,20/15.2 x 8 x 42,5	B1				<b>81-3320</b>
						026 109 101M	<b>50 006 397</b> (1)
(1) Schalenhartguss/chilled cast iron/pièce moulée trempée en surface/fundición en coquilla/Отливка с отбеленным поверхностным слоем							
	[8]	H 35 x 26 x 26				034 109 309 034 109 309 AC 034 109 309 AD 034 109 309 N 074 109 309	<b>50 006 460</b>
<b>215</b>		<b>81</b>					
<b>RH</b> 93 928 6..		B (NA) 4	1781 cm <sup>3</sup> 2V	62 kW (84 PS) 10	86,40 mm		
	EX [2]	33,0 x 8 x 91,2	A/S - -	- 45° - VS -	22 - III	048 109 611 A 053 109 611	<b>33048</b>
	[50]	∅ 8 mm				113 109 651 A 400 501 068	<b>MK-8H</b>
	IN/EX [4]	12,06/15 x 8 x 36,5	B1			056 103 419 A	<b>81-3310</b>
	IN/EX [4]	12,07/15.2 x 8 x 42,5	B1			049 103 419	<b>81-3319</b>
	IN/EX [4]	12,13/15 x 8 x 36,5	B1				<b>81-3312</b>
	IN/EX [4]	12,20/15 x 8 x 36,5	B1				<b>81-3311</b>
	IN/EX [4]	12,20/15.2 x 8 x 42,5	B1				<b>81-3320</b>
						026109101Q	<b>50 007 594</b> (1)
(1) Schalenhartguss/chilled cast iron/pièce moulée trempée en surface/fundición en coquilla/Отливка с отбеленным поверхностным слоем							
	[8]	H 35 x 26 x 26				034 109 309 034 109 309 AC 034 109 309 AD 034 109 309 N 074 109 309	<b>50 006 460</b>

V

					Reference	Item No.	
<b>216</b>	81						
RP 93 876 6..	08.1987 →	B (NA)	4	1781 cm <sup>3</sup> 2V	65-66 kW (88-90 PS) 10	86,40 mm	
	IN [2]	38,0 x 8 x 91,9	S - -	- 45° - VS -	22 - III	035 109 601 J 035 109 601 K	<b>33282</b>
	EX [2]	33,0 x 8 x 91,2	A/S - -	- 45° - VS -	22 - III	048 109 611 A 053 109 611	<b>33048</b>
	[50]	∅ 8 mm				113 109 651 A 400 501 068	<b>MK-8H</b>
	IN/EX [4]	12,06/15 x 8 x 36,5	B1			056 103 419 A	<b>81-3310</b>
	IN/EX [4]	12,07/15.2 x 8 x 42,5	B1			049 103 419	<b>81-3319</b>
	IN/EX [4]	12,13/15 x 8 x 36,5	B1				<b>81-3312</b>
	IN/EX [4]	12,20/15 x 8 x 36,5	B1				<b>81-3311</b>
	IN/EX [4]	12,20/15.2 x 8 x 42,5	B1				<b>81-3320</b>
						026109101Q	<b>50 007 594</b> (1)
	(1) Schalenhartguss/chilled cast iron/pièce moulée trempée en surface/fundición en coquilla/Отливка с отбелнным поверхностным слоем						
	[8]	H 35 x 26 x 26				034 109 309 034 109 309 AC 034 109 309 AD 034 109 309 N 074 109 309	<b>50 006 460</b>
<b>217</b>	81						
1F 93 872 6..	04.1988 → 02.2002	B (NA)	4	1595 cm <sup>3</sup> 2V	55 kW (75 PS) 9	77,40 mm	
	IN [2]	38,0 x 8 x 91,9	S - -	- 45° - VS -	22 - III	035 109 601 J 035 109 601 K	<b>33282</b>
	EX [2]	33,0 x 8 x 91,2	A/S - -	- 45° - VS -	22 - III	048 109 611 A 053 109 611	<b>33048</b>
	[50]	∅ 8 mm				113 109 651 A 400 501 068	<b>MK-8H</b>
	IN/EX [4]	12,06/15 x 8 x 36,5	B1			056 103 419 A	<b>81-3310</b>
	IN/EX [4]	12,07/15.2 x 8 x 42,5	B1			049 103 419	<b>81-3319</b>
	IN/EX [4]	12,13/15 x 8 x 36,5	B1				<b>81-3312</b>
	IN/EX [4]	12,20/15 x 8 x 36,5	B1				<b>81-3311</b>
	IN/EX [4]	12,20/15.2 x 8 x 42,5	B1				<b>81-3320</b>
						026 109 101M	<b>50 006 397</b> (1)
	(1) Schalenhartguss/chilled cast iron/pièce moulée trempée en surface/fundición en coquilla/Отливка с отбелнным поверхностным слоем						
	[8]	H 35 x 26 x 26				050 109 309 050 109 309 A 050 109 309 H 050 109 309 J	<b>50 006 417</b>
<b>218</b>	81						
1H	08.1988 → 03.1990	B (K)	4	1781 cm <sup>3</sup> 2V	118 kW (160 PS) 8	86,40 mm	
	[8]	H 35 x 26 x 26				034 109 309 034 109 309 AC 034 109 309 AD 034 109 309 N 074 109 309	<b>50 006 460</b>



					Reference	Item No.		
<b>219</b>		<b>81</b>						
<b>1P</b>	08.1988 → 07.1991	B (NA)	4	1781 cm <sup>3</sup>	2V	72 kW (98 PS)	9	86,40 mm
<b>AAF</b>	11.1990 → 12.1993	B (NA)	5	2461 cm <sup>3</sup>	2V	80-81 kW (108-110 PS)	8,5	95,50 mm
<b>ACU</b>	01.1994 → 04.2003	B (NA)	5	2461 cm <sup>3</sup>	2V	80-81 kW (108-110 PS)	8,5	95,50 mm
<b>AEN</b>	09.1990 → 06.2003	B (NA)	5	2461 cm <sup>3</sup>	2V	81 kW (110 PS)	10	95,50 mm
<b>PG</b>	08.1988 → 05.1997	B (K)	4	1781 cm <sup>3</sup>	2V	110-118 kW (150-160 PS)	8	86,40 mm
90 942 6.., 93 928 6..								
	IN [2] EX [2]	39,5 x 8 x 91,9 33,0 x 8 x 91,2	S - Cr - A/S - -	- 45° - VS - - 45° - VS -	22 - III 22 - III	048 109 601 A 048 109 611 A 053 109 611	<b>33313</b> <b>33048</b>	
	[50]	Ø 8 mm				113 109 651 A 400 501 068	<b>MK-8H</b>	
	IN/EX [4] IN/EX [4] IN/EX [4]	12,06/15 x 8 x 36,5 12,13/15 x 8 x 36,5 12,20/15 x 8 x 36,5	B1 B1 B1			056 103 419 A	<b>81-3310</b> <b>81-3312</b> <b>81-3311</b>	
	[8]	H 35 x 26 x 26				034 109 309 034 109 309 AC 034 109 309 AD 034 109 309 N 074 109 309	<b>50 006 460</b>	
<b>220</b>		<b>81</b>						
<b>2H</b>	08.1989 → 12.1996	B (NA)	4	1781 cm <sup>3</sup>	2V	72 kW (98 PS)	9	86,40 mm
93 928 6..								
	IN [2] EX [2]	38,0 x 8 x 91,9 33,0 x 8 x 91,2	S - - A/S - -	- 45° - VS - - 45° - VS -	22 - III 22 - III	035 109 601 J 035 109 601 K 048 109 611 A 053 109 611	<b>33282</b> <b>33048</b>	
	[50]	Ø 8 mm				113 109 651 A 400 501 068	<b>MK-8H</b>	
	IN/EX [4] IN/EX [4] IN/EX [4]	12,06/15 x 8 x 36,5 12,13/15 x 8 x 36,5 12,20/15 x 8 x 36,5	B1 B1 B1			056 103 419 A	<b>81-3310</b> <b>81-3312</b> <b>81-3311</b>	
<b>221</b>		<b>81</b>						
<b>AAC</b>	07.1990 → 04.2003	B (NA)	4	1968 cm <sup>3</sup>	2V	62 kW (84 PS)	8,5	95,50 mm
90 942 6..								
	IN [2]	39,5 x 7 x 91,9	S - -	- 45° - -	22 - III	06A 109 601E 078 109 601A 078 109 601B 078 109 601E 078 109 601F	<b>33403</b>	
	IN [2] EX [2]	39,5 x 8 x 91,9 33,0 x 7 x 91,2	S - Cr - A/S - -	- 45° - VS - - 45° - VS -	22 - III 22 - III	048 109 601 A 048 109 611B 078 109 611C	<b>33313</b> <b>33416</b>	
	EX [2]	33,0 x 8 x 91,2	A/S - -	- 45° - VS -	22 - III	048 109 611 A 053 109 611	<b>33048</b>	
	[50] [50]	Ø 7 mm Ø 8 mm				021 109 651 113 109 651 A 400 501 068	<b>MK-7H</b> <b>MK-8H</b>	
	IN/EX [4] IN/EX [4]	12,06/15 x 8 x 36,5 12,08/15 x 7 x 36,5	B1 B1			056 103 419 A 037 103 415 037 103 419 B	<b>81-3310</b> <b>81-33103</b>	
	IN/EX [4] IN/EX [4] IN/EX [4]	12,13/15 x 8 x 36,5 12,20/15 x 8 x 36,5 12,25/15 x 7 x 36,5	B1 B1 B1				<b>81-3312</b> <b>81-3311</b> <b>81-33104</b>	
Fortsetzung nächste Seite / continued on next page / suite page suivante / continuación página próxima / Продолжение на следующей странице								

V

					Reference	Item No.
[8]	H 35 x 26 x 26				034 109 309 034 109 309 AC 034 109 309 AD 034 109 309 N 074 109 309	<b>50 006 460</b>

## 222

81

**AAM** 08.1990 → B (NA) 4 1781 cm<sup>3</sup> 2V 55 kW (75 PS) 9 86,40 mm  
93 876 6..

IN [2]	38,0 x 8 x 91,9	S - -	- 45° - VS -	22 - III	035 109 601 J 035 109 601 K	<b>33282</b>
EX [2]	33,0 x 7 x 91,2	A/S - -	- 45° - VS -	22 - III	048 109 611B 078 109 611C	<b>33416</b>
EX [2]	33,0 x 8 x 91,2	A/S - -	- 45° - VS -	22 - III	048 109 611 A 053 109 611	<b>33048</b>
[50]	∅ 7 mm				021 109 651	<b>MK-7H</b>
[50]	∅ 8 mm				113 109 651 A 400 501 068	<b>MK-8H</b>
IN/EX [4]	12,06/15 x 8 x 36,5	B1			056 103 419 A	<b>81-3310</b>
IN/EX [4]	12,08/15 x 7 x 36,5	B1			037 103 415 037 103 419 B	<b>81-33103</b>
IN/EX [4]	12,13/15 x 8 x 36,5	B1				<b>81-3312</b>
IN/EX [4]	12,20/15 x 8 x 36,5	B1				<b>81-3311</b>
IN/EX [4]	12,25/15 x 7 x 36,5	B1				<b>81-33104</b>
					026 109 101M	<b>50 006 397</b> (1)
	(1) Schalenhartguss/chilled cast iron/pièce moulée trempée en surface/fundición en coquilla/Отливка с отбеленным поверхностным слоем					
[8]	H 35 x 26 x 26				034 109 309 034 109 309 AC 034 109 309 AD 034 109 309 N 074 109 309	<b>50 006 460</b>

## 223

81

**AEU** 09.1990 → 06.2003 B (NA) 5 2461 cm<sup>3</sup> 2V 81 kW (110 PS) 10 95,50 mm  
90 942 6..

IN [2]	39,5 x 8 x 91,9	S - Cr -	- 45° - VS -	22 - III	048 109 601 A	<b>33313</b>
EX [2]	33,0 x 8 x 91,2	A/S - -	- 45° - VS -	22 - III	048 109 611 A 053 109 611	<b>33048</b>
[50]	∅ 8 mm				113 109 651 A 400 501 068	<b>MK-8H</b>
IN/EX [4]	12,06/15 x 8 x 36,5	B1			056 103 419 A	<b>81-3310</b>
IN/EX [4]	12,13/15 x 8 x 36,5	B1				<b>81-3312</b>
IN/EX [4]	12,20/15 x 8 x 36,5	B1				<b>81-3311</b>
[8]	H 35 x 26 x 26				050 109 309 050 109 309 A 050 109 309 H 050 109 309 J	<b>50 006 417</b>

## 224

81

**PD** 12.1990 → 07.1992 B (NA) 4 1781 cm<sup>3</sup> 2V 49 kW (67 PS) 9 86,40 mm

IN [2]	38,0 x 8 x 91,9	S - -	- 45° - VS -	22 - III	035 109 601 J 035 109 601 K	<b>33282</b>
EX [2]	33,0 x 8 x 91,2	A/S - -	- 45° - VS -	22 - III	048 109 611 A 053 109 611	<b>33048</b>

Fortsetzung nächste Seite / continued on next page / suite page suivante / continuación página próxima / Продолжение на следующей странице



KOLBENSCHMIDT

TRW  
EngineComponents

## VOLKSWAGEN

					Reference	Item No.
[50]	Ø 8 mm				113 109 651 A 400 501 068	<b>MK-8H</b>
IN/EX [4]	12,06/15 x 8 x 36,5	B1			056 103 419 A	<b>81-3310</b>
IN/EX [4]	12,13/15 x 8 x 36,5	B1				<b>81-3312</b>
IN/EX [4]	12,20/15 x 8 x 36,5	B1				<b>81-3311</b>
[8]	H 35 x 26 x 26				034 109 309 034 109 309 AC 034 109 309 AD 034 109 309 N 074 109 309	<b>50 006 460</b>

**225** **81**

AAA

B (NA) 6 2792 cm<sup>3</sup> 2V 120-128 kW (163-174 PS) 10 90,30 mm

91 033 6..

IN [2]	39,0 x 7 x 106,0	S - -	- 45° - -	22 - III		<b>331040</b>
EX [2]	34,2 x 7 x 106,9	RA/S- -	- 45° - VS -	22 - III	021 109 611G	<b>331109</b>
[50]	Ø 7 mm				021 109 651	<b>MK-7H</b>
IN/EX [4]	12,08/15 x 7 x 38,0	B1			027 103 419	<b>81-33100</b>
[8]	H 35 x 26 x 26				034 109 309 034 109 309 AC 034 109 309 AD 034 109 309 N 074 109 309	<b>50 006 460</b>

**226** **81**

ABS

08.1991 → 09.2001 B (NA) 4 1781 cm<sup>3</sup> 2V 63-66 kW (86-90 PS) 10 86,40 mm

93 928 6..

IN [2]	38,0 x 8 x 91,9	S - -	- 45° - VS -	22 - III	035 109 601 J 035 109 601 K	<b>33282</b>
EX [2]	33,0 x 8 x 91,2	A/S - -	- 45° - VS -	22 - III	048 109 611 A 053 109 611	<b>33048</b>
[50]	Ø 8 mm				113 109 651 A 400 501 068	<b>MK-8H</b>
IN/EX [4]	12,06/15 x 8 x 36,5	B1			056 103 419 A	<b>81-3310</b>
IN/EX [4]	12,13/15 x 8 x 36,5	B1				<b>81-3312</b>
IN/EX [4]	12,20/15 x 8 x 36,5	B1				<b>81-3311</b>
					026109101Q	<b>50 007 594</b> (1)
	(1) Schalenhartguss/chilled cast iron/pièce moulée trempée en surface/fundición en coquilla/Отливка с отбеленным поверхностным слоем					
[8]	H 35 x 26 x 26				050 109 309 050 109 309 A 050 109 309 H 050 109 309 J	<b>50 006 417</b>
[8]	H 35 x 26 x 26				034 109 309 034 109 309 AC 034 109 309 AD 034 109 309 N 074 109 309	<b>50 006 460</b>

**227** **81**

ADZ

08.1991 → B (NA) 4 1781 cm<sup>3</sup> 2V 63-66 kW (86-90 PS) 9 86,40 mm

93 928 6..

Fortsetzung nächste Seite / continued on next page / suite page suivante / continuación página próxima / Продолжение на следующей странице

					Reference	Item No.
IN [2]	38,0 x 8 x 91,9	S - -	- 45° - VS -	22 - III	035 109 601 J 035 109 601 K	<b>33282</b>
EX [2]	33,0 x 7 x 91,2	A/S - -	- 45° - VS -	22 - III	048 109 611B 078 109 611C	<b>33416</b>
EX [2]	33,0 x 8 x 91,2	A/S - -	- 45° - VS -	22 - III	048 109 611 A 053 109 611	<b>33048</b>
[50]	∅ 7 mm				021 109 651	<b>MK-7H</b>
[50]	∅ 8 mm				113 109 651 A 400 501 068	<b>MK-8H</b>
IN/EX [4]	12,06/15 x 8 x 36,5	B1			056 103 419 A	<b>81-3310</b>
IN/EX [4]	12,08/15 x 7 x 36,5	B1			037 103 415 037 103 419 B	<b>81-33103</b>
IN/EX [4]	12,13/15 x 8 x 36,5	B1				<b>81-3312</b>
IN/EX [4]	12,20/15 x 8 x 36,5	B1				<b>81-3311</b>
IN/EX [4]	12,25/15 x 7 x 36,5	B1				<b>81-33104</b>
					026109101Q	<b>50 007 594</b> (1)
	(1) Schalenhartguss/chilled cast iron/pièce moulée trempée en surface/fundición en coquilla/Отливка с отбелнным поверхностным слоем					
[8]	H 35 x 26 x 26				050 109 309 050 109 309 A 050 109 309 H 050 109 309 J	<b>50 006 417</b>
[8]	H 35 x 26 x 26				034 109 309 034 109 309 AC 034 109 309 AD 034 109 309 N 074 109 309	<b>50 006 460</b>

**228**
**81**
**ADD** 11.1991 → 09.2005 B (NA) 4 1781 cm<sup>3</sup> 2V 63-75 kW (86-102 PS) 10 86,40 mm  
 93 876 6..

IN [2]	38,0 x 8 x 91,9	S - -	- 45° - VS -	22 - III	035 109 601 J 035 109 601 K	<b>33282</b>
EX [2]	33,0 x 8 x 91,2	A/S - -	- 45° - VS -	22 - III	048 109 611 A 053 109 611	<b>33048</b>
[50]	∅ 8 mm				113 109 651 A 400 501 068	<b>MK-8H</b>
IN/EX [4]	12,06/15 x 8 x 36,5	B1			056 103 419 A	<b>81-3310</b>
IN/EX [4]	12,08/15 x 7 x 36,5	B1			037 103 415 037 103 419 B	<b>81-33103</b>
IN/EX [4]	12,13/15 x 8 x 36,5	B1				<b>81-3312</b>
IN/EX [4]	12,20/15 x 8 x 36,5	B1				<b>81-3311</b>
IN/EX [4]	12,25/15 x 7 x 36,5	B1				<b>81-33104</b>
[8]	H 35 x 26 x 26				050 109 309 050 109 309 A 050 109 309 H 050 109 309 J	<b>50 006 417</b>

**229**
**81**
**ACC** 11.1991 → B (NA) 4 1781 cm<sup>3</sup> 2V 66-67 kW (90-91 PS) 10 86,40 mm  
 93 876 6..

IN [2]	38,0 x 8 x 91,9	S - -	- 45° - VS -	22 - III	035 109 601 J 035 109 601 K	<b>33282</b>
EX [2]	33,0 x 8 x 91,2	A/S - -	- 45° - VS -	22 - III	048 109 611 A 053 109 611	<b>33048</b>
[50]	∅ 8 mm				113 109 651 A 400 501 068	<b>MK-8H</b>

Fortsetzung nächste Seite / continued on next page / suite page suivante / continuación página próxima / Продолжение на следующей странице

					Reference	Item No.	
	IN/EX [4] 12,06/15 x 8 x 36,5 IN/EX [4] 12,08/15 x 7 x 36,5	B1 B1			056 103 419 A 037 103 415 037 103 419 B	<b>81-3310</b> <b>81-33103</b>	
	IN/EX [4] 12,13/15 x 8 x 36,5 IN/EX [4] 12,20/15 x 8 x 36,5 IN/EX [4] 12,25/15 x 7 x 36,5	B1 B1 B1				<b>81-3312</b> <b>81-3311</b> <b>81-33104</b>	
					026109101Q	<b>50 007 594</b> (1)	
	(1) Schalenhartguss/chilled cast iron/pièce moulée trempée en surface/fundición en coquilla/Отливка с отбелсным поверхностным слоем						
	[8] H 35 x 26 x 26				050 109 309 050 109 309 A 050 109 309 H 050 109 309 J	<b>50 006 417</b>	

**230**
**81**
**ANN** 07.1993 → 06.2002 B (NA) 4 1781 cm<sup>3</sup> 2V 55 kW (75 PS) 9 86,40 mm  
93 876 6..

	EX [2] 33,0 x 7 x 91,2	A/S - - - 45° - VS - 22 - III			048 109 611B 078 109 611C	<b>33416</b>	
	[50] Ø 7 mm				021 109 651	<b>MK-7H</b>	
	IN/EX [4] 12,08/15 x 7 x 36,5 IN/EX [4] 12,25/15 x 7 x 36,5	B1 B1			037 103 415 037 103 419 B	<b>81-33103</b> <b>81-33104</b>	
					026 109 101M	<b>50 006 397</b> (1)	
	(1) Schalenhartguss/chilled cast iron/pièce moulée trempée en surface/fundición en coquilla/Отливка с отбелсным поверхностным слоем						
	[8] H 35 x 26 x 26				050 109 309 050 109 309 A 050 109 309 H 050 109 309 J	<b>50 006 417</b>	

**231**
**81**
**ANP** 07.1993 → 06.2002 B (NA) 4 1781 cm<sup>3</sup> 2V 66 kW (90 PS) 10 86,40 mm

	EX [2] 33,0 x 7 x 91,2	A/S - - - 45° - VS - 22 - III			048 109 611B 078 109 611C	<b>33416</b>	
	[50] Ø 7 mm				021 109 651	<b>MK-7H</b>	
	IN/EX [4] 12,08/15 x 7 x 36,5 IN/EX [4] 12,25/15 x 7 x 36,5	B1 B1			037 103 415 037 103 419 B	<b>81-33103</b> <b>81-33104</b>	
					026109101Q	<b>50 007 594</b> (1)	
	(1) Schalenhartguss/chilled cast iron/pièce moulée trempée en surface/fundición en coquilla/Отливка с отбелсным поверхностным слоем						

**232**
**81**
**AEK** 07.1994 → 12.1995 B (NA) 4 1595 cm<sup>3</sup> 2V 74 kW (101 PS) 10,3 77,40 mm  
94 503 7..

Fortsetzung nächste Seite / continued on next page / suite page suivante / continuación página próxima / Продолжение на следующей странице

					Reference	Item No.
IN [2]	39,5 x 7 x 91,9	S - -	- 45° - -	22 - III	06A 109 601E 078 109 601A 078 109 601B 078 109 601E 078 109 601F	<b>33403</b>
IN [2]	39,5 x 8 x 91,9	S - Cr -	- 45° - VS -	22 - III	048 109 601 A	<b>33313</b>
EX [2]	33,0 x 7 x 91,2	A/S - -	- 45° - VS -	22 - III	048 109 611B 078 109 611C	<b>33416</b>
EX [2]	33,0 x 8 x 91,2	A/S - -	- 45° - VS -	22 - III	048 109 611 A 053 109 611	<b>33048</b>
[50]	Ø 7 mm				021 109 651	<b>MK-7H</b>
[50]	Ø 8 mm				113 109 651 A 400 501 068	<b>MK-8H</b>
IN/EX [4]	12,06/15 x 8 x 36,5	B1			056 103 419 A	<b>81-3310</b>
IN/EX [4]	12,08/15 x 7 x 36,5	B1			037 103 415 037 103 419 B	<b>81-33103</b>
IN/EX [4]	12,13/15 x 8 x 36,5	B1				<b>81-3312</b>
IN/EX [4]	12,20/15 x 8 x 36,5	B1				<b>81-3311</b>
IN/EX [4]	12,25/15 x 7 x 36,5	B1				<b>81-33104</b>
[8]	H 35 x 26 x 26				050 109 309 050 109 309 A 050 109 309 H 050 109 309 J	<b>50 006 417</b>
[8]	H 35 x 26 x 26				034 109 309 034 109 309 AC 034 109 309 AD 034 109 309 N 074 109 309	<b>50 006 460</b>

## 233

**81**

<b>AES</b>	11.1995 → 05.2000	B	(NA)	6	2792 cm <sup>3</sup>	2V	103 kW	(140 PS)	10	90,30 mm
<b>AMY</b>	09.1995 → 04.2000	B	(NA)	6	2792 cm <sup>3</sup>	2V	128 kW	(174 PS)	10	90,30 mm

91 033 6..

IN [2]	39,0 x 7 x 106,0	S - -	- 45° - -	22 - III		<b>331040</b>
EX [2]	34,2 x 7 x 106,9	RA/S- -	- 45° - VS -	22 - III	021 109 611G	<b>331109</b>
[50]	Ø 7 mm				021 109 651	<b>MK-7H</b>
IN/EX [4]	12,08/15 x 7 x 36,5	B1			037 103 415 037 103 419 B	<b>81-33103</b>
IN/EX [4]	12,08/15 x 7 x 38,0	B1			027 103 419	<b>81-33100</b>
IN/EX [4]	12,25/15 x 7 x 36,5	B1				<b>81-33104</b>
[8]	H 35 x 26 x 26				034 109 309 034 109 309 AC 034 109 309 AD 034 109 309 N 074 109 309	<b>50 006 460</b>

## 234

**81**

<b>AFT</b>	12.1995 → 06.2002	B	(NA)	4	1595 cm <sup>3</sup>	2V	74 kW	(101 PS)	10,5	77,40 mm
------------	-------------------	---	------	---	----------------------	----	-------	----------	------	----------

94 503 7..

IN [2]	39,5 x 7 x 91,9	S - -	- 45° - -	22 - III	06A 109 601E 078 109 601A 078 109 601B 078 109 601E 078 109 601F	<b>33403</b>
EX [2]	33,0 x 7 x 91,2	A/S - -	- 45° - VS -	22 - III	048 109 611B 078 109 611C	<b>33416</b>
[50]	Ø 7 mm				021 109 651	<b>MK-7H</b>

Fortsetzung nächste Seite / continued on next page / suite page suivante / continuación página próxima / Продолжение на следующей странице



					Reference	Item No.
	IN/EX [4] 12,06/15 x 8 x 36,5 IN/EX [4] 12,08/15 x 7 x 36,5	B1 B1			056 103 419 A 037 103 415 037 103 419 B	<b>81-3310</b> <b>81-33103</b>
	IN/EX [4] 12,13/15 x 8 x 36,5 IN/EX [4] 12,20/15 x 8 x 36,5 IN/EX [4] 12,25/15 x 7 x 36,5	B1 B1 B1				<b>81-3312</b> <b>81-3311</b> <b>81-33104</b>
					050 109 101A	<b>50 006 398</b> (1)
	(1) Schalenhartguss/chilled cast iron/pièce moulée trempée en surface/fundición en coquilla/Отливка с отбеленным поверхностным слоем					
	[8] H 35 x 26 x 26				050 109 309 050 109 309 A 050 109 309 H 050 109 309 J	<b>50 006 417</b>

## 235 81

ADP	10.1996 → 11.2000	B (NA)	4	1595 cm <sup>3</sup>	2V	74 kW	(101 PS)	10,3	77,40 mm
AEH	09.1997 → 05.2005	B (NA)	4	1595 cm <sup>3</sup>	2V	74 kW	(100 PS)	10,3	77,40 mm
AHL	10.1996 → 11.2000	B (NA)	4	1595 cm <sup>3</sup>	2V	74 kW	(101 PS)	10,3	77,40 mm
AKL	05.1996 → 05.2005	B (NA)	4	1595 cm <sup>3</sup>	2V	65-76 kW	(100-103 PS)	10,3	77,40 mm
ANA	10.1996 → 11.2000	B (NA)	4	1595 cm <sup>3</sup>	2V	74 kW	(101 PS)	10,3	77,40 mm
APF	12.1995 → 05.2005	B (NA)	4	1595 cm <sup>3</sup>	2V	74 kW	(101 PS)	10,3	77,40 mm
ARM	10.1996 → 11.2000	B (NA)	4	1595 cm <sup>3</sup>	2V	74 kW	(101 PS)	10,3	77,40 mm
AUR	05.2000 → 09.2001	B (NA)	4	1595 cm <sup>3</sup>	2V	74 kW	(101 PS)	10,3	77,40 mm
AWH	10.1999 → 09.2000	B (NA)	4	1595 cm <sup>3</sup>	2V	74 kW	(101 PS)	10,3	77,40 mm

94 503 7... 99 792 6...

	IN [2] 39,5 x 7 x 91,9	S - -	- 45° -	-	22 - III	06A 109 601E 078 109 601A 078 109 601B 078 109 601E 078 109 601F	<b>33403</b>
	EX [2] 33,0 x 7 x 91,2	A/S - -	- 45° -	VS -	22 - III	048 109 611B 078 109 611C	<b>33416</b>
	[50] Ø 7 mm					021 109 651	<b>MK-7H</b>
	IN/EX [4] 12,08/15 x 7 x 36,5 IN/EX [4] 12,25/15 x 7 x 36,5	B1 B1				037 103 415 037 103 419 B	<b>81-33103</b> <b>81-33104</b>
						050 109 101A	<b>50 006 398</b> (1)
	(1) Schalenhartguss/chilled cast iron/pièce moulée trempée en surface/fundición en coquilla/Отливка с отбеленным поверхностным слоем						
	[8] H 35 x 26 x 26					050 109 309 050 109 309 A 050 109 309 H 050 109 309 J	<b>50 006 417</b>

## 236 81

AET	08.1996 → 04.2003	B (NA)	5	2461 cm <sup>3</sup>	2V	81-85 kW	(110-115 PS)	8,5	95,50 mm
AVT	07.1996 → 04.2003	B (NA)	5	2461 cm <sup>3</sup>	2V	85 kW	(115 PS)	10	95,50 mm

	IN [2] 39,5 x 8 x 91,9 EX [2] 33,0 x 8 x 91,2	S - Cr - A/S - -	- 45° -	VS -	22 - III 22 - III	048 109 601 A 048 109 611 A 053 109 611	<b>33313</b> <b>33048</b>
	IN/EX [4] 12,06/15 x 8 x 36,5 IN/EX [4] 12,13/15 x 8 x 36,5 IN/EX [4] 12,20/15 x 8 x 36,5	B1 B1 B1				056 103 419 A	<b>81-3310</b> <b>81-3312</b> <b>81-3311</b>

Fortsetzung nächste Seite / continued on next page / suite page suivante / continuación página próxima / Продолжение на следующей странице

					Reference	Item No.	
[8]	H 35 x 26 x 26				034 109 309 034 109 309 AC 034 109 309 AD 034 109 309 N 074 109 309	<b>50 006 460</b>	
<b>237</b> <b>81</b>							
<b>ADR</b>	10.1996 → 11.2000	B (NA)	4	1781 cm <sup>3</sup>	5V 92 kW (125 PS)	10,3 86,40 mm	
<b>APT</b>	01.1999 → 11.2000	B (NA)	4	1781 cm <sup>3</sup>	5V 92 kW (125 PS)	10,3 86,40 mm	
<b>ARG</b>	02.1999 → 11.2000	B (NA)	4	1781 cm <sup>3</sup>	5V 92 kW (125 PS)	10,3 86,40 mm	
IN [2]	27,0 x 6 x 105,1	S - -		- 45° - VS -	22 - III	058 109 601 C 058 109 601 P	<b>33413</b>
EX [2]	30,1 x 6 x 103,9	RA/S- Cr -		- 45° - VS -	22 - III	058 109 611 M 06B 109 611 D	<b>331107</b>
[50]	Ø 6 mm					036 109 651A	<b>MK-6H</b>
IN/EX [4]	11,04 x 6 x 39,0	B1				058 103 415	<b>81-33121</b>
IN/EX [4]	11,05 x 6 x 36,0	B1					<b>81-33111</b>
IN/EX [4]	11,15 x 6 x 36,0	B1					<b>81-33118</b>
EX [4]	11,04 x 6 x 39,0	G2					<b>81-33122</b>
	ES AS  (1) F-3B-WD050 155 >> F-3B-DE064 364 >> F-3B-WP081 180 >> / Schalenhartguss/chilled cast iron/pièce moulée trempée en surface/fundición en coquilla/Отливка с отбелнным поверхностным слоем					058 109 021K 058 109 022 C	<b>50 007 579</b> (1) <b>50 007 580</b> (1)
[8]	H 24 x 24 x 24					058 109 309 B 058 109 309 F 058 109 309 J	<b>50 006 425</b> (2)
[8]	H 33,5 x 25,6 x 25,6  (2) Einlass/intake/admission/entrada/коллектора (3) Auslass/Exhaust/sortie/salida/Выпуск					058 109 309 A 058 109 309 E 058 109 309 K	<b>50 006 426</b> (3)
<b>238</b> <b>81</b>							
<b>AGZ</b>	10.1996 → 06.2006	B (NA)	5	2324 cm <sup>3</sup>	2V 110 kW (150 PS)	10,1 90,20 mm	
91 033 6..							
IN [2]	39,0 x 7 x 106,0	S - -		- 45° - - -	22 - III	021 109 601 H 021 109 601 J 021 109 601 K	<b>331040</b>
IN [2]	39,0 x 7 x 106,0	S - -		- 45° - VS -	22 - III		<b>39372</b>
EX [2]	34,0 x 7 x 107,0	RA/S- -		- 45° - VS -	22 - III		021 109 611 D <b>39300</b>
[50]	Ø 7 mm					021 109 651	<b>MK-7H</b>
IN/EX [4]	12,08/15 x 7 x 38,0	B1				027 103 419	<b>81-33100</b>
[8]	H 35 x 26 x 26					034 109 309 034 109 309 AC 034 109 309 AD 034 109 309 N 074 109 309	<b>50 006 460</b>

					Reference	Item No.			
<b>239</b>		<b>81</b>							
<b>AEB</b>	10.1996 → 12.1998	B (A)	4	1781 cm <sup>3</sup>	5V	110-112 kW (150-152 PS)	9,5	86,40 mm	
<b>AGU Euro 2</b>	08.1997 → 09.2010	B (LA)	4	1781 cm <sup>3</sup>	5V	110 kW (150 PS)	9,5	86,40 mm	
<b>AJH</b>	09.1997 → 03.2010	B (LA)	4	1781 cm <sup>3</sup>	5V	110 kW (150 PS)	9,5	86,40 mm	
<b>ANB</b>	01.1999 → 11.2000	B (A)	4	1781 cm <sup>3</sup>	5V	110 kW (150 PS)	9,5	86,40 mm	
<b>APH</b>	10.1999 → 06.2000	B (A)	4	1781 cm <sup>3</sup>	5V	110 kW (150 PS)	9,5	86,40 mm	
<b>APU</b>	05.1997 → 11.2000	B (LA)	4	1781 cm <sup>3</sup>	5V	110 kW (150 PS)	9,5	86,40 mm	
<b>AQA</b>	05.1998 → 04.2000	B (A)	4	1781 cm <sup>3</sup>	5V	110 kW (150 PS)	9,5	86,40 mm	
<b>ARZ</b>	08.1997 → 06.2006	B (A)	4	1781 cm <sup>3</sup>	5V	110 kW (150 PS)	9,5	86,40 mm	
<b>AWC</b>	04.2000 → 03.2010	B (LA)	4	1781 cm <sup>3</sup>	5V	110 kW (150 PS)	9,5	86,40 mm	
99 933 6..									
	IN [2]	27,0 x 6 x 105,1	S - -	- 45° - VS -	22 - III	058 109 601 C 058 109 601 P		<b>33413</b>	
	EX [2]	30,0 x 6 x 103,8	RA/S- Cr - Na	- 45° - VS -	22 - III	058 109 611 E		<b>33394</b>	(1)
	EX [2]	30,0 x 6 x 103,9	RA/S- Cr -	- 45° - VS -	22 - III			<b>331108</b>	(2)
	(1)	OES specification							
	(2)	IAM specification							
	[50]	∅ 6 mm				036 109 651A		<b>MK-6H</b>	
	IN/EX [4]	11,04 x 6 x 39,0	B1					<b>81-33121</b>	
	IN/EX [4]	11,05 x 6 x 36,0	B1			058 103 415		<b>81-33111</b>	
	IN/EX [4]	11,15 x 6 x 36,0	B1					<b>81-33118</b>	
	EX [4]	11,04 x 6 x 39,0	G2					<b>81-33122</b>	
		ES AS				058 109 021 B 058 109 022 B		<b>50 006 307</b> (3) <b>50 006 308</b> (3)	
	(3)	Schalenhartguss/chilled cast iron/pièce moulée trempée en surface/fundición en coquilla/Отливка с отбеленным поверхностным слоем							
	[8]	H 24 x 24 x 24				058 109 309 B 058 109 309 F 058 109 309 J		<b>50 006 425</b> (4)	
	[8]	H 33,5 x 25,6 x 25,6				058 109 309 A 058 109 309 E 058 109 309 K		<b>50 006 426</b> (5)	
	(4)	Einlass/intake/admission/entrada/коллектора							
	(5)	Auslass/Exhaust/sortie/salida/Выпуск							
<b>240</b>		<b>81</b>							
<b>AFY</b>	01.1997 → 03.2005	B (NA)	4	1781 cm <sup>3</sup>	5V	85 kW (115 PS)	10	86,40 mm	
	IN [2]	27,0 x 6 x 105,1	S - -	- 45° - VS -	22 - III	058 109 601 C 058 109 601 P		<b>33413</b>	
	EX [2]	30,1 x 6 x 103,9	RA/S- Cr -	- 45° - VS -	22 - III	058 109 611 M 06B 109 611 D		<b>331107</b>	
	[50]	∅ 6 mm				036 109 651A		<b>MK-6H</b>	
	IN/EX [4]	11,04 x 6 x 39,0	B1					<b>81-33121</b>	
	IN/EX [4]	11,05 x 6 x 36,0	B1			058 103 415		<b>81-33111</b>	
	IN/EX [4]	11,15 x 6 x 36,0	B1					<b>81-33118</b>	
	EX [4]	11,04 x 6 x 39,0	G2					<b>81-33122</b>	
		AS				058 109 022 C		<b>50 007 580</b> (1)	
	(1)	F-3B-WD050 155 >>> F-3B-DE064 364 >>> F-3B-WP081 180 >>> / Schalenhartguss/chilled cast iron/pièce moulée trempée en surface/fundición en coquilla/Отливка с отбеленным поверхностным слоем							
Fortsetzung nächste Seite / continued on next page / suite page suivante / continuación página próxima / Продолжение на следующей странице									

					Reference	Item No.
[8]	H 24 x 24 x 24				058 109 309 B 058 109 309 F 058 109 309 J	<b>50 006 425</b> (2)
[8]	H 33,5 x 25,6 x 25,6				058 109 309 A 058 109 309 E 058 109 309 K	<b>50 006 426</b> (3)
	(2) Einlass/intake/admission/entrada/коллектора					
	(3) Auslass/Exhaust/sortie/salida/Выпуск					

**241**
**81**
**AKS** 04.1997 → 06.2002 B (NA) 4 1595 cm<sup>3</sup> 2V 74 kW (101 PS) 10,3 77,40 mm  
 94 503 7..

IN [2]	39,5 x 7 x 91,9	S - -	- 45° - -	22 - III	06A 109 601E 078 109 601A 078 109 601B 078 109 601E 078 109 601F	<b>33403</b>
EX [2]	33,0 x 7 x 91,2	A/S - -	- 45° - VS -	22 - III	048 109 611B 078 109 611C	<b>33416</b>
[50]	∅ 7 mm				021 109 651	<b>MK-7H</b>
IN/EX [4]	12,06/15 x 8 x 36,5	B1			056 103 419 A	<b>81-3310</b>
IN/EX [4]	12,13/15 x 8 x 36,5	B1				<b>81-3312</b>
IN/EX [4]	12,20/15 x 8 x 36,5	B1				<b>81-3311</b>
					050 109 101A	<b>50 006 398</b> (1)
	(1) Schalenhartguss/chilled cast iron/pièce moulée trempée en surface/fundición en coquilla/Отливка с отбелнным поверхностным слоем					
[8]	H 35 x 26 x 26				034 109 309 034 109 309 AC 034 109 309 AD 034 109 309 N 074 109 309	<b>50 006 460</b>

**242**
**81**
**AGN** 08.1997 → 06.2006 B (NA) 4 1781 cm<sup>3</sup> 5V 92 kW (125 PS) 10,3 86,40 mm

IN [2]	27,0 x 6 x 105,1	S - -	- 45° - VS -	22 - III	058 109 601 C 058 109 601 P	<b>33413</b>
EX [2]	30,1 x 6 x 103,9	RA/S- Cr -	- 45° - VS -	22 - III	058 109 611 M 06B 109 611 D	<b>331107</b>
[50]	∅ 6 mm				036 109 651A	<b>MK-6H</b>
IN/EX [4]	11,04 x 6 x 39,0	B1				<b>81-33121</b>
IN/EX [4]	11,05 x 6 x 36,0	B1			058 103 415	<b>81-33111</b>
IN/EX [4]	11,15 x 6 x 36,0	B1				<b>81-33118</b>
EX [4]	11,04 x 6 x 39,0	G2				<b>81-33122</b>
[8]	H 24 x 24 x 24				058 109 309 B 058 109 309 F 058 109 309 J	<b>50 006 425</b> (1)
[8]	H 33,5 x 25,6 x 25,6				058 109 309 A 058 109 309 E 058 109 309 K	<b>50 006 426</b> (2)
	(1) Einlass/intake/admission/entrada/коллектора					
	(2) Auslass/Exhaust/sortie/salida/Выпуск					

					Reference	Item No.	
<b>243</b>		<b>81</b>					
<b>AUM</b>	08.1997 → 06.2006	B (LA)	4	1781 cm <sup>3</sup> 5V	110 kW (150 PS)	9,5 86,40 mm	
<b>AUQ</b>	06.2000 →	B (A)	4	1781 cm <sup>3</sup> 5V	132-142 kW (180-193 PS)	9,5 86,40 mm	
<b>AWU</b>	10.2000 → 09.2010	B (A)	4	1781 cm <sup>3</sup> 5V	110 kW (150 PS)	9,5 86,40 mm	
<b>AWV</b>	06.2000 → 09.2010	B (A)	4	1781 cm <sup>3</sup> 5V	110 kW (150 PS)	9,5 86,40 mm	
40 434 6..							
	IN [2]	27,0 x 6 x 105,1	S - -	- 45° - VS -	22 - III	058 109 601 C 058 109 601 P	<b>33413</b>
	EX [2]	30,0 x 6 x 103,8	RA/S- Cr - Na	- 45° - VS -	22 - III	058 109 611 E	<b>33394</b> (1)
	EX [2]	30,0 x 6 x 103,9	RA/S- Cr -	- 45° - VS -	22 - III		<b>331108</b> (2)
	(1)	OES specification					
	(2)	IAM specification					
	[50]	Ø 6 mm				036 109 651A	<b>MK-6H</b>
	IN/EX [4]	11,04 x 6 x 39,0	B1				<b>81-33121</b>
	IN/EX [4]	11,05 x 6 x 36,0	B1			058 103 415	<b>81-33111</b>
	IN/EX [4]	11,15 x 6 x 36,0	B1				<b>81-33118</b>
	EX [4]	11,04 x 6 x 39,0	G2				<b>81-33122</b>
		AS ES				058 109 022 B 058 109 021 M	<b>50 006 308</b> (3) <b>50 007 581</b> (3)
	(3)	Schalenhartguss/chilled cast iron/pièce moulée trempée en surface/fundición en coquilla/Отливка с отбеленным поверхностным слоем					
	[8]	H 24 x 24 x 24				058 109 309 B 058 109 309 F 058 109 309 J	<b>50 006 425</b> (4)
	[8]	H 33,5 x 25,6 x 25,6				058 109 309 A 058 109 309 E 058 109 309 K	<b>50 006 426</b> (5)
	(4)	Einlass/intake/admission/entrada/коллектора					
	(5)	Auslass/Exhaust/sortie/salida/Выпуск					
<b>244</b>		<b>81</b>					
<b>BAF</b>		B (NA)	4	1781 cm <sup>3</sup> 5V	92 kW (125 PS)	10,3 86,40 mm	
	IN/EX [4]	11,04 x 6 x 39,0	B1				<b>81-33121</b>
	IN/EX [4]	11,05 x 6 x 36,0	B1			058 103 415	<b>81-33111</b>
	IN/EX [4]	11,15 x 6 x 36,0	B1				<b>81-33118</b>
	EX [4]	11,04 x 6 x 39,0	G2				<b>81-33122</b>
<b>245</b>		<b>81</b>					
<b>AQP</b>	03.1999 → 06.2006	B (NA)	6	2792 cm <sup>3</sup> 4V	150 kW (204 PS)	10,75 90,30 mm	
<b>AUE</b>	03.1999 → 06.2006	B (NA)	6	2792 cm <sup>3</sup> 4V	150 kW (204 PS)	10,75 90,30 mm	
	IN [2]	31,0 x 6 x 102,1	S - -	- 45° - - -	22 - III	022 109 601 E	<b>331041</b>
	IN [2]	31,0 x 6 x 136,1	S - -	- 45° - - -	22 - III	022 109 601 F	<b>331135</b>
	EX [2]	27,0 x 6 x 102,5	RA/S- Cr -	- 45° - VS -	22 - III	022 109 611 B	<b>331136</b>
	EX [2]	27,0 x 6 x 136,4	A/S - -	- 45° - VS -	22 - III	022 109 611 C	<b>331042</b>
	[50]	Ø 6 mm				036 109 651A	<b>MK-6H</b>
	IN/EX [4]	11,04 x 6 x 39,0	B1				<b>81-33121</b>
	IN/EX [4]	11,05 x 6 x 36,0	B1			058 103 415	<b>81-33111</b>
	IN/EX [4]	11,15 x 6 x 36,0	B1				<b>81-33118</b>
	EX [4]	11,04 x 6 x 39,0	G2				<b>81-33122</b>
	[8]	H 12 x 34,5				022 109 423 B 022 109 423 C	<b>50 006 491</b>

V

					Reference	Item No.	
<b>246</b>	81						
<b>BDE</b>	03.1999 → 06.2006	B (NA)	6	2792 cm <sup>3</sup> 4V	150 kW (204 PS)	10,75 90,30 mm	
<b>BDF</b>	10.2001 → 07.2005	B (NA)	6	2792 cm <sup>3</sup> 4V	147 kW (200 PS)	10,75 90,30 mm	
	IN [2]	31,0 x 6 x 102,1	S - -	- 45° - -	22 - III	022 109 601 E	<b>331041</b>
	IN [2]	31,0 x 6 x 136,1	S - -	- 45° - -	22 - III	022 109 601F	<b>331135</b>
	EX [2]	27,0 x 6 x 102,5	RA/S- Cr -	- 45° - VS -	22 - III	022 109 611B	<b>331136</b>
	EX [2]	27,0 x 6 x 136,4	A/S - -	- 45° - VS -	22 - III	022 109 611 C	<b>331042</b>
	[50]	Ø 6 mm				036 109 651A	<b>MK-6H</b>
	[8]	H 12 x 34,5				022 109 423 B 022 109 423 C	<b>50 006 491</b>
	[4]					022 109 417 C 022 109 417 E	<b>50 006 144</b>
<b>247</b>	81						
<b>APL</b>	05.1999 → 04.2003	B (NA)	5	2461 cm <sup>3</sup> 2V	85 kW (115 PS)	10 95,50 mm	
	IN [2]	39,5 x 8 x 91,9	S - Cr -	- 45° - VS -	22 - III	048 109 601 A	<b>33313</b>
	EX [2]	33,0 x 8 x 91,2	A/S - -	- 45° - VS -	22 - III	048 109 611 A 053 109 611	<b>33048</b>
	[50]	Ø 8 mm				113 109 651 A 400 501 068	<b>MK-8H</b>
	IN/EX [4]	12,06/15 x 8 x 36,5	B1			056 103 419 A	<b>81-3310</b>
	IN/EX [4]	12,13/15 x 8 x 36,5	B1				<b>81-3312</b>
	IN/EX [4]	12,20/15 x 8 x 36,5	B1				<b>81-3311</b>
<b>248</b>	81						
<b>AWM</b>	02.2001 → 11.2005	B (LA)	4	1781 cm <sup>3</sup> 5V	125 kW (170 PS)	9,3:1 86,40 mm	
<b>AWP</b>	06.2000 →	B (A)	4	1781 cm <sup>3</sup> 5V	132 kW (180 PS)	9,5 86,40 mm	
<b>AWT</b>	11.2000 → 05.2005	B (A)	4	1781 cm <sup>3</sup> 5V	110 kW (150 PS)	9,5 86,40 mm	
<b>BBU</b>	05.2006 → 11.2009	B (LA)	4	1781 cm <sup>3</sup> 5V	132 kW (180 PS)	9,5 86,40 mm	
<b>BJX</b>	09.2005 → 11.2009	B (A)	4	1781 cm <sup>3</sup> 5V	110 kW (150 PS)	9,5 86,40 mm	
<b>BKF</b>	10.1999 → 09.2010	B (LA)	4	1781 cm <sup>3</sup> 5V	110 kW (150 PS)	9,5 86,40 mm	
<b>BNU</b>	07.2004 → 06.2005	B (LA)	4	1781 cm <sup>3</sup> 5V	132 kW (180 PS)	9,5 86,40 mm	
40 434 6..							
	IN [2]	27,0 x 6 x 105,1	S - -	- 45° - VS -	22 - III	058 109 601 C 058 109 601 P	<b>33413</b>
	EX [2]	30,0 x 6 x 103,8	RA/S- Cr - Na	- 45° - VS -	22 - III	058 109 611 E	<b>33394</b> (1)
	EX [2]	30,0 x 6 x 103,9	RA/S- Cr -	- 45° - VS -	22 - III		<b>331108</b> (2)
	(1) OES specification						
	(2) IAM specification						
	[50]	Ø 6 mm				036 109 651A	<b>MK-6H</b>
	IN/EX [4]	11,04 x 6 x 39,0	B1			058 103 415	<b>81-33121</b>
	IN/EX [4]	11,05 x 6 x 36,0	B1				<b>81-33111</b>
	IN/EX [4]	11,15 x 6 x 36,0	B1				<b>81-33118</b>
	EX [4]	11,04 x 6 x 39,0	G2				<b>81-33122</b>
		ES				058 109 021 M	<b>50 007 581</b> (3)
	(3) Schalenhartguss/chilled cast iron/pièce moulée trempée en surface/fundición en coquilla/Отливка с отбеленным поверхностным слоем						
Fortsetzung nächste Seite / continued on next page / suite page suivante / continuación página próxima / Продолжение на следующей странице							



					Reference	Item No.
[8]	H 24 x 24 x 24				058 109 309 B 058 109 309 F 058 109 309 J	<b>50 006 425</b> (4)
[8]	H 33,5 x 25,6 x 25,6				058 109 309 A 058 109 309 E 058 109 309 K	<b>50 006 426</b> (5)
	(4) Einlass/intake/admission/entrada/коллектора					
	(5) Auslass/Exhaust/sortie/salida/Выпуск					

## 249 81

<b>AMV Euro 3</b>	04.2000 → 04.2003	B (NA)	6	2792 cm <sup>3</sup>	4V	150 kW	(204 PS)	10,75	90,30 mm
<b>AQN</b>	10.2000 → 09.2010	B (NA)	5	2324 cm <sup>3</sup>	4V	125 kW	(170 PS)	10,8	90,20 mm
<b>AYL</b>	04.2000 → 03.2010	B (NA)	6	2792 cm <sup>3</sup>	4V	150 kW	(204 PS)	10,5	90,30 mm
<b>AZX</b>	11.2000 → 05.2005	B (NA)	5	2324 cm <sup>3</sup>	4V	125 kW	(170 PS)	10,8	90,20 mm

IN [2]	31,0 x 6 x 102,1	S - -	- 45° - -	22 - III	022 109 601 E	<b>331041</b>
IN [2]	31,0 x 6 x 136,1	S - -	- 45° - -	22 - III	022 109 601F	<b>331135</b>
EX [2]	27,0 x 6 x 102,5	RA/S- Cr -	- 45° - VS -	22 - III	022 109 611B	<b>331136</b>
EX [2]	27,0 x 6 x 136,4	A/S - -	- 45° - VS -	22 - III	022 109 611 C	<b>331042</b>
[50]	Ø 6 mm				036 109 651A	<b>MK-6H</b>
[8]	H 12 x 34,5				022 109 423 B 022 109 423 C	<b>50 006 491</b>

## 250 81

<b>ARX</b>	05.2000 → 05.2005	B (LA)	4	1781 cm <sup>3</sup>	5V	110 kW	(150 PS)	9,5	86,40 mm
40 434 6..									

IN [2]	27,0 x 6 x 105,1	S - -	- 45° - VS -	22 - III	058 109 601 C 058 109 601 P	<b>33413</b>
EX [2]	30,0 x 6 x 103,8	RA/S- Cr - Na	- 45° - VS -	22 - III	058 109 611 E	<b>33394</b> (1)
EX [2]	30,0 x 6 x 103,9	RA/S- Cr -	- 45° - VS -	22 - III		<b>331108</b> (2)
	(1) OES specification					
	(2) IAM specification					
[50]	Ø 6 mm				036 109 651A	<b>MK-6H</b>
IN/EX [4]	11,04 x 6 x 39,0	B1			058 103 415	<b>81-33121</b> <small>NEW</small>
IN/EX [4]	11,05 x 6 x 36,0	B1				<b>81-33111</b>
IN/EX [4]	11,15 x 6 x 36,0	B1				<b>81-33118</b> <small>NEW</small>
EX [4]	11,04 x 6 x 39,0	G2				<b>81-33122</b> <small>NEW</small>
[8]	H 24 x 24 x 24				058 109 309 B 058 109 309 F 058 109 309 J	<b>50 006 425</b> (3)
[8]	H 33,5 x 25,6 x 25,6				058 109 309 A 058 109 309 E 058 109 309 K	<b>50 006 426</b> (4)
	(3) Einlass/intake/admission/entrada/коллектора					
	(4) Auslass/Exhaust/sortie/salida/Выпуск					

## 251 81

<b>AVC</b>	06.2000 → 10.2000	B (A)	4	1781 cm <sup>3</sup>	5V	110 kW	(150 PS)	9,5	86,40 mm
99 933 6..									

IN [2]	27,0 x 6 x 105,1	S - -	- 45° - VS -	22 - III	058 109 601 C 058 109 601 P	<b>33413</b>
EX [2]	30,0 x 6 x 103,8	RA/S- Cr - Na	- 45° - VS -	22 - III	058 109 611 E	<b>33394</b> (1)
EX [2]	30,0 x 6 x 103,9	RA/S- Cr -	- 45° - VS -	22 - III		<b>331108</b> (2)
	(1) OES specification					

Fortsetzung nächste Seite / continued on next page / suite page suivante / continuación página próxima / Продолжение на следующей странице

					Reference	Item No.
(2)	IAM specification					
[50]	Ø 6 mm				036 109 651A	<b>MK-6H</b>
	IN/EX [4] 11,04 x 6 x 39,0 IN/EX [4] 11,05 x 6 x 36,0 IN/EX [4] 11,15 x 6 x 36,0 EX [4] 11,04 x 6 x 39,0	B1 B1 B1 G2			058 103 415	<b>81-33121</b> <b>81-33111</b> <b>81-33118</b> <b>81-33122</b>
	ES AS				058 109 021 B 058 109 022 B	<b>50 006 307</b> (3) <b>50 006 308</b> (3)
(3)	Schalenhartguss/chilled cast iron/pièce moulée trempée en surface/fundición en coquilla/Отливка с отбеленным поверхностным слоем					
[8]	H 12 x 34,8 x 34,8				030 109 423 030 109 423 A 030 109 423 B 036 109 423 A 036 109 423 D CP40239	<b>50 006 415</b>
[8]	H 24 x 24 x 24				058 109 309 B 058 109 309 F 058 109 309 J	<b>50 006 425</b> (4)
[8]	H 33,5 x 25,6 x 25,6				058 109 309 A 058 109 309 E 058 109 309 K	<b>50 006 426</b> (5)
(4)	Einlass/intake/admission/entrada/коллектора					
(5)	Auslass/Exhaust/sortie/salida/Выпуск					
[4]					030 109 417 D	<b>50 006 141</b>

**252**
**81**

<b>AVU</b>	08.2000 → 06.2006	B	(NA)	4	1595 cm <sup>3</sup>	2V	75 kW	(102 PS)	10,3	77,40 mm
<b>AYD</b>	06.2000 → 09.2010	B	(NA)	4	1595 cm <sup>3</sup>	2V	75 kW	(102 PS)	10,5	77,40 mm

99 792 6..

IN [2]	39,5 x 6 x 94,0	S - -	- 45° - -	22 - III	06B 109 601B 06B 109 601D 06B 109 601H	<b>331057</b>
EX [2]	32,9 x 6 x 93,9	A/S - -	- 45° - VS -	22 - III	06B 109 611 C 06B 109 611B	<b>331058</b>
[50]	Ø 6 mm				036 109 651A	<b>MK-6H</b>
	IN/EX [4] 11,04 x 6 x 39,0 IN/EX [4] 11,05 x 6 x 36,0 IN/EX [4] 11,15 x 6 x 36,0 IN/EX [4] 12,06 x 5.99 x 36,4 EX [4] 11,04 x 6 x 39,0	B1 B1 B1 B1 G2			058 103 415	<b>81-33121</b> <b>81-33111</b> <b>81-33118</b> <b>81-33113</b> <b>81-33122</b>
					06B 109 101 G 06B 109 101 Q	<b>50 006 309</b> (1)
(1)	Schalenhartguss/chilled cast iron/pièce moulée trempée en surface/fundición en coquilla/Отливка с отбеленным поверхностным слоем					
[8]	H 12 x 34,5				022 109 423 A 022 109 423 D	<b>50 006 419</b>
[4]					06B 109 417 C	<b>50 006 147</b>

					Reference	Item No.	
<b>253</b> <b>81</b>							
<b>BFS</b> 99 792 6..	06.2000 → 09.2010	B	(NA)	4	1595 cm <sup>3</sup> 2V	75 kW (102 PS) 10,5 77,40 mm	
IN [2]	39,5 x 6 x 94,0	S	-	-	- 45° - -	22 - III 06B 109 601B 06B 109 601D 06B 109 601H	<b>331057</b>
EX [2]	32,9 x 6 x 93,9	A/S	-	-	- 45° - VS -	22 - III 06B 109 611 C 06B 109 611B	<b>331058</b>
[50]	∅ 6 mm					036 109 651A	<b>MK-6H</b>
IN/EX [4]	12,06 x 5.99 x 36,4	B1					<b>81-33113</b>
						06B 109 101 G 06B 109 101 Q	<b>50 006 309</b> (1)
	(1) Schalenhartguss/chilled cast iron/pièce moulée trempée en surface/fundición en coquilla/Отливка с отбеленным поверхностным слоем						
[8]	H 12 x 34,5					022 109 423 A 022 109 423 D	<b>50 006 419</b>
[4]						06B 109 417 C	<b>50 006 147</b>
<b>254</b> <b>81</b>							
<b>BFO</b> 99 792 6..	08.2000 → 06.2006	B	(NA)	4	1595 cm <sup>3</sup> 2V	75 kW (102 PS) 10,3 77,40 mm	
<b>CMXA Euro 5</b>	05.2005 → 12.2013	B	(NA)	4	1595 cm <sup>3</sup> 2V	75 kW (102 PS) 10,5 77,40 mm	
IN [2]	39,5 x 6 x 94,0	S	-	-	- 45° - -	22 - III 06B 109 601B 06B 109 601D 06B 109 601H	<b>331057</b>
EX [2]	32,9 x 6 x 93,9	A/S	-	-	- 45° - VS -	22 - III 06B 109 611 C 06B 109 611B	<b>331058</b>
[50]	∅ 6 mm					036 109 651A	<b>MK-6H</b>
IN/EX [4]	12,06 x 5.99 x 36,4	B1					<b>81-33113</b>
IN/EX [4]	12,08 x 5.98 x 36,5	B1					<b>81-33114</b>
[8]	H 12 x 34,5					022 109 423 A 022 109 423 D	<b>50 006 419</b>
[4]						06B 109 417 C	<b>50 006 147</b>
<b>255</b> <b>81</b>							
<b>ALZ</b> 99 792 6..	11.2000 → 05.2005	B	(NA)	4	1595 cm <sup>3</sup> 2V	75 kW (102 PS) 10,3:1 77,40 mm	
IN [2]	39,5 x 6 x 94,0	S	-	-	- 45° - -	22 - III 06B 109 601B 06B 109 601D 06B 109 601H	<b>331057</b>
EX [2]	32,9 x 6 x 93,9	A/S	-	-	- 45° - VS -	22 - III 06B 109 611 C 06B 109 611B	<b>331058</b>
[50]	∅ 6 mm					036 109 651A	<b>MK-6H</b>
Fortsetzung nächste Seite / continued on next page / suite page suivante / continuación página próxima / Продолжение на следующей странице							

V

					Reference	Item No.
	IN/EX [4] 11,04 x 6 x 39,0 IN/EX [4] 11,05 x 6 x 36,0 IN/EX [4] 11,15 x 6 x 36,0 IN/EX [4] 12,06 x 5.99 x 36,4 EX [4] 11,04 x 6 x 39,0	B1 B1 B1 B1 G2			058 103 415	<b>81-33121</b> <small>NEW</small> <b>81-33111</b> <b>81-33118</b> <small>NEW</small> <b>81-33113</b> <b>81-33122</b> <small>NEW</small>
	[8] H 12 x 34,5				022 109 423 A 022 109 423 D	<b>50 006 419</b>
	[4]				06B 109 417 C	<b>50 006 147</b>

## 256



**BGU Euro 4** 07.2003 → 05.2015 B (NA) 4 1595 cm<sup>3</sup> 2V 75 kW (102 PS) 10,5 77,40 mm  
99 792 6..

	IN [2] 39,5 x 6 x 94,0 EX [2] 32,9 x 6 x 93,9	S - - A/S - -	- 45° - - - 45° - VS -	22 - III 22 - III	06B 109 601B 06B 109 601D 06B 109 601H 06B 109 611 C 06B 109 611B	<b>331057</b> <b>331058</b>
	[50] Ø 6 mm				036 109 651A	<b>MK-6H</b>
	IN/EX [4] 11,04 x 6 x 39,0 IN/EX [4] 11,05 x 6 x 36,0 IN/EX [4] 11,15 x 6 x 36,0 IN/EX [4] 12,06 x 5.99 x 36,4 IN/EX [4] 12,08 x 5.98 x 36,5 EX [4] 11,04 x 6 x 39,0	B1 B1 B1 B1 B1 G2			058 103 415	<b>81-33121</b> <small>NEW</small> <b>81-33111</b> <b>81-33118</b> <small>NEW</small> <b>81-33113</b> <b>81-33114</b> <b>81-33122</b> <small>NEW</small>
	[8] H 12 x 34,5				022 109 423 A 022 109 423 D	<b>50 006 419</b>
	[4]				06B 109 417 C	<b>50 006 147</b>

## 257



**BSE Euro 4/5** 07.2003 → 05.2015 B (NA) 4 1595 cm<sup>3</sup> 2V 75 kW (102 PS) 10,5 77,40 mm  
**BSF Euro 2** 07.2003 → 05.2015 B (NA) 4 1595 cm<sup>3</sup> 2V 75 kW (102 PS) 10,5 77,40 mm  
**CCSA Euro 4/5** 01.2004 → 12.2013 B (NA) 4 1595 cm<sup>3</sup> 2V 75 kW (102 PS) 10,5 77,40 mm  
99 792 6..

	IN [2] 39,5 x 6 x 94,0 EX [2] 32,9 x 6 x 93,9	S - - A/S - -	- 45° - - - 45° - VS -	22 - III 22 - III	06B 109 601B 06B 109 601D 06B 109 601H 06B 109 611 C 06B 109 611B	<b>331057</b> <b>331058</b>
	[50] Ø 6 mm				036 109 651A	<b>MK-6H</b>
	IN/EX [4] 12,06 x 5.99 x 36,4 IN/EX [4] 12,08 x 5.98 x 36,5 IN/EX [1] 12,06 x 6 x 38,5	B1 B1 B1				<b>81-33113</b> <b>81-33114</b> <b>81-33125</b> <small>NEW</small>
	[8] H 12 x 34,5				022 109 423 A 022 109 423 D	<b>50 006 419</b>
	[4]				06B 109 417 C	<b>50 006 147</b>

## 258



**HM** 08.1983 → 12.1999 AB (NA) 4 1595 cm<sup>3</sup> 2V 53-60 kW (72-82 PS) 9 77,40 mm  
93 872 6..

Fortsetzung nächste Seite / continued on next page / suite page suivante / continuación página próxima / Продолжение на следующей странице

					Reference	Item No.
	IN [2] 38,0 x 8 x 98,6	S - -	- 45° - -	22 - III	035 109 601 C 035 109 601 D 035 109 601 F 035 109 603	<b>33022</b>
	EX [2] 33,0 x 8 x 91,2	A/S - -	- 45° - VS -	22 - III	048 109 611 A 053 109 611	<b>33048</b>
	EX [2] 33,0 x 8 x 98,5	A/S - Cr -	- 45° - VS -	22 - III	035 109 611 F 035 109 611 H	<b>33023</b>
	[50] Ø 8 mm				113 109 651 A 400 501 068	<b>MK-8H</b>
	IN/EX [4] 12,06/15 x 8 x 36,5	B1			056 103 419 A	<b>81-3310</b>
	IN/EX [4] 12,07/15.2 x 8 x 42,5	B1			049 103 419	<b>81-3319</b>
	IN/EX [4] 12,13/15 x 8 x 36,5	B1				<b>81-3312</b>
	IN/EX [4] 12,20/15 x 8 x 36,5	B1				<b>81-3311</b>
	IN/EX [4] 12,20/15.2 x 8 x 42,5	B1				<b>81-3320</b>
					026 109 101M	<b>50 006 397</b> (1)
	(1) Schalenhartguss/chilled cast iron/pièce moulée trempée en surface/fundición en coquilla/Отливка с отбелсным поверхностным слоем					
	[8] H 35 x 26 x 26				034 109 309 034 109 309 AC 034 109 309 AD 034 109 309 N 074 109 309	<b>50 006 460</b>
	[8] M 35 x 28,5				056 109 311 A	<b>50 007 621</b>

**259**
**81**

ACV	09.1995 → 04.2003	D (LA)	5	2461 cm <sup>3</sup>	2V	75 kW	(102 PS)	19,5	95,50 mm
AGX	07.1996 → 07.2006	D (LA)	5	2461 cm <sup>3</sup>	2V	55 kW	(75 PS)	19,5	95,50 mm
AHD	05.1996 → 08.1999	D (LA)	5	2461 cm <sup>3</sup>	2V	75 kW	(102 PS)	19,5	95,50 mm
AHY	05.1998 → 04.2003	D (LA)	5	2461 cm <sup>3</sup>	2V	111 kW	(151 PS)	19,5:1	95,50 mm
AJT	05.1998 → 04.2003	D (A)	5	2461 cm <sup>3</sup>	2V	65 kW	(88 PS)	19,5:1	95,50 mm
ANJ	05.1999 → 07.2006	D (A)	5	2461 cm <sup>3</sup>	2V	80 kW	(109 PS)	19,5	95,50 mm
APA	05.1999 → 07.2006	D (LA)	5	2461 cm <sup>3</sup>	2V	66 kW	(90 PS)	19,5:1	95,50 mm
AUF	09.1995 → 04.2003	D (A)	5	2461 cm <sup>3</sup>	2V	75 kW	(102 PS)	19,5:1	95,50 mm
AVR	05.1999 → 07.2006	D (LA)	5	2461 cm <sup>3</sup>	2V	80 kW	(109 PS)	19,5	95,50 mm
AXG	05.1998 → 04.2003	D (A)	5	2461 cm <sup>3</sup>	2V	111 kW	(151 PS)	19,5	95,50 mm
AXL	09.1995 → 04.2003	D (LA)	5	2461 cm <sup>3</sup>	2V	75 kW	(102 PS)	19,5	95,50 mm
AYC	09.1995 → 04.2003	D (A)	5	2461 cm <sup>3</sup>	2V	75 kW	(102 PS)	19,5	95,50 mm
AYY	05.1998 → 04.2003	D (A)	5	2461 cm <sup>3</sup>	2V	65 kW	(88 PS)	18	95,50 mm
BBE	05.2001 → 07.2006	D (A)	5	2461 cm <sup>3</sup>	2V	61 kW	(83 PS)	19,5:1	95,50 mm
BBF	05.2001 → 07.2006	D (A)	5	2461 cm <sup>3</sup>	2V	70 kW	(95 PS)	19,5:1	95,50 mm

40 734 6..., 99 742 7..., 99 743 7..

	IN [2] 36,0 x 8 x 96,9	RA/S- -	- 45° - VS -	22 - III	028 109 601 H 028 109 601A 046 109 601G 046 109 601J 049 109 601J	<b>39423</b> (1)
	IN [2] 36,1 x 8 x 96,9	S - -	- 45° - -	22 - III		<b>331141</b> (2)
	EX [2] 31,6 x 8 x 96,9	RA/S- -	- 45° - -	22 - III	046 109 611 C 046 109 611 E 046 109 611 F	<b>331142</b>
	(1) OES specification					
	(2) IAM specification					
	[50] Ø 8 mm				113 109 651 A 400 501 068	<b>MK-8H</b>

Fortsetzung nächste Seite / continued on next page / suite page suivante / continuación página próxima / Продолжение на следующей странице

					Reference	Item No.
	IN/EX [4] 12,06/15 x 8 x 36,5 IN/EX [4] 12,13/15 x 8 x 36,5 IN/EX [4] 12,20/15 x 8 x 36,5	B1 B1 B1			056 103 419 A	<b>81-3310</b> <b>81-3312</b> <b>81-3311</b>
	(3) Schalenhartguss/chilled cast iron/pièce moulée trempée en surface/fundición en coquilla/Отливка с отбелсным поверхностным слоем				046 109 101K 074 109 101 E 074 109 101J	<b>50 006 283</b> (3)
	[8] H 35 x 26 x 26				034 109 309 034 109 309 AC 034 109 309 AD 034 109 309 N 074 109 309	<b>50 006 460</b>
	- - G - S -  CAM - V - G - S -	- SB - - - SB - -	 35 Nm 60 Nm 2 x 90° 90° warm/chaud/caliente		074 103 351 C  074 103 265 EX	<b>50 003 115</b>  <b>50 003 415</b>
			ready-to-install			

## 260

ANF	02.2002 →	D (NA)	5	2461 cm <sup>3</sup>	2V	55 kW	(75 PS)	19,5:1	95,50 mm
ANG	02.2002 →	D (A)	5	2461 cm <sup>3</sup>	2V	88 kW	(120 PS)	19,5:1	95,50 mm
ANH	02.2002 →	D (A)	5	2461 cm <sup>3</sup>	2V	111 kW	(151 PS)	19,5:1	95,50 mm
BBR	01.2003 →	D (LA)	5	2461 cm <sup>3</sup>	2V	80 kW	(109 PS)	19,5:1	95,50 mm
BCT		D (NA)	5	2461 cm <sup>3</sup>	2V	40 kW	(55 PS)	19,5:1	95,50 mm
BCU	02.2002 →	D (A)	5	2461 cm <sup>3</sup>	2V	74 kW	(100 PS)	19,5:1	95,50 mm
BCV	02.2002 →	D (A)	5	2461 cm <sup>3</sup>	2V	108 kW	(147 PS)	19,5:1	95,50 mm
BTW	04.2005 →	D (A)	5	2461 cm <sup>3</sup>	2V	121 kW	(165 PS)	18:1	95,50 mm

40 734 6..., 99 742 7..., 99 743 7..

	IN [2]	36,0 x 8 x 96,9	RA/S- -	- 45° - VS -	22 - III	028 109 601 H 028 109 601A 046 109 601G 046 109 601J 049 109 601J	<b>39423</b> (1)
	IN [2] EX [2]	36,1 x 8 x 96,9 31,6 x 8 x 96,9	S - - RA/S- -	- 45° - - - 45° - -	22 - III 22 - III	046 109 611 C 046 109 611 E 046 109 611 F	<b>331141</b> (2) <b>331142</b>
	(1) OES specification (2) IAM specification						
	[50]	Ø 8 mm				113 109 651 A 400 501 068	<b>MK-8H</b>
	IN/EX [4] IN/EX [4] IN/EX [4]	12,06/15 x 8 x 36,5 12,13/15 x 8 x 36,5 12,20/15 x 8 x 36,5	B1 B1 B1			056 103 419 A	<b>81-3310</b> <b>81-3312</b> <b>81-3311</b>
	(3) Schalenhartguss/chilled cast iron/pièce moulée trempée en surface/fundición en coquilla/Отливка с отбелсным поверхностным слоем					046 109 101K 074 109 101 E 074 109 101J	<b>50 006 283</b> (3)

## 261

AYH	10.2002 → 05.2010	D (LA)	10	4921 cm <sup>3</sup>	2V	230 kW	(313 PS)	18,5	95,50 mm
-----	-------------------	--------	----	----------------------	----	--------	----------	------	----------

Fortsetzung nächste Seite / continued on next page / suite page suivante / continuación página próxima / Продолжение на следующей странице



					Reference	Item No.
IN [2] EX [2]	35,9 x 7 x 89,9 31,5 x 7 x 90,0	S - - A/S - -	- 45° - - - 45° - VS -	22 - III 22 - III	038 109 601 B 038 109 611 B 038 109 611 F	<b>331033</b> <b>331034</b>
[50]	Ø 7 mm				021 109 651	<b>MK-7H</b>
IN/EX [4]	12,08/15 x 7 x 38,0	B1			027 103 419	<b>81-33100</b>
					07Z 109 101K 07Z 109 101J	<b>50 006 107</b> (1) <b>50 006 109</b> (2)
	(1) für Zylinder/for cylinder/pour cylindre/para cilindro/для цилиндров 6-10 / (ST) (2) für Zylinder/for cylinder/pour cylindre/para cilindro/для цилиндров 1-5 / (ST)					
[8]	H 35 x 26 x 26				038 109 309 A 038 109 309 B 038 109 309 C	<b>50 006 418</b>

## 262



<b>BLE</b>		10.2002 → 05.2010		D (LA)	10	4921 cm <sup>3</sup>	2V	230 kW	(313 PS)	18,5	95,50 mm
<b>CBWA</b>		08.2007 → 05.2010		D (LA)	10	4921 cm <sup>3</sup>	2V	230-257 kW	(313-350 PS)	18,5:1	95,50 mm
IN [2] EX [2]	36,0 x 7 x 89,5 31,5 x 7 x 89,0	S - - RA/S- -	- 45° - - - 45° - VS -	22 - III 22 - III	038 109 601 E 038 109 611 E	<b>331123</b> <b>331124</b>					
[50]	Ø 7 mm				021 109 651	<b>MK-7H</b>					
IN/EX [4]	12,08/15 x 7 x 36,5	B1			037 103 415 037 103 419 B	<b>81-33103</b>					
IN/EX [4]	12,25/15 x 7 x 36,5	B1				<b>81-33104</b>					
					07Z 109 101F 07Z 109 101E	<b>50 006 106</b> (1) <b>50 006 399</b> (2)					
	(1) für Zylinder/for cylinder/pour cylindre/para cilindro/для цилиндров 6-10 / (ST) (2) für Zylinder/for cylinder/pour cylindre/para cilindro/для цилиндров 1-5 / Schalenhartguss/chilled cast iron/pièce moulée trempée en surface/fundición en coquilla/Отливка с отбеленным поверхностным слоем										
[8]	H 35 x 26 x 26				038 109 309 A 038 109 309 B 038 109 309 C	<b>50 006 418</b>					

## 263



<b>BWF</b>		10.2002 → 05.2010		D (LA)	10	4921 cm <sup>3</sup>	2V	230 kW	(313 PS)	18,5	95,50 mm
IN [2] EX [2]	36,0 x 7 x 89,5 31,5 x 7 x 89,0	S - - RA/S- -	- 45° - - - 45° - VS -	22 - III 22 - III	038 109 601 E 038 109 611 E	<b>331123</b> <b>331124</b>					
[50]	Ø 7 mm				021 109 651	<b>MK-7H</b>					
IN/EX [4]	12,08/15 x 7 x 36,5	B1			037 103 415 037 103 419 B	<b>81-33103</b>					
IN/EX [4]	12,08/15 x 7 x 38,0	B1			027 103 419	<b>81-33100</b>					
IN/EX [4]	12,25/15 x 7 x 36,5	B1				<b>81-33104</b>					
[8]	H 35 x 26 x 26				038 109 309 A 038 109 309 B 038 109 309 C	<b>50 006 418</b>					

## 264



<b>AJS</b>		11.2002 → 10.2006		D (A)	10	4921 cm <sup>3</sup>	2V	230 kW	(313 PS)	18	95,50 mm
------------	--	-------------------	--	-------	----	----------------------	----	--------	----------	----	----------

Fortsetzung nächste Seite / continued on next page / suite page suivante / continuación página próxima / Продолжение на следующей странице

					Reference	Item No.
IN [2] EX [2]	35,9 x 7 x 89,9 31,5 x 7 x 90,0	S - - A/S - -	- 45° - - - 45° - VS -	22 - III 22 - III	038 109 601 B 038 109 611 B 038 109 611 F	<b>331033</b> <b>331034</b>
[50]	Ø 7 mm				021 109 651	<b>MK-7H</b>
IN/EX [4]	12,08/15 x 7 x 36,5	B1			037 103 415 037 103 419 B	<b>81-33103</b>
IN/EX [4]	12,08/15 x 7 x 38,0	B1			027 103 419	<b>81-33100</b>
IN/EX [4]	12,25/15 x 7 x 36,5	B1				<b>81-33104</b>
[8]	H 35 x 26 x 26				038 109 309 A 038 109 309 B 038 109 309 C	<b>50 006 418</b>

## 265 81

<b>AXD Euro 3</b>	04.2003 → 11.2009	D (LA)	5	2461 cm <sup>3</sup>	2V	96 kW	(130 PS)	18	95,50 mm
<b>BAC</b>	01.2003 → 05.2010	D (LA)	5	2461 cm <sup>3</sup>	2V	128 kW	(174 PS)	18,5	95,50 mm
<b>BLJ</b>	11.2003 → 11.2009	D (LA)	5	2461 cm <sup>3</sup>	2V	120 kW	(163 PS)	18	95,50 mm
<b>BLK</b>	08.2003 → 05.2010	D (LA)	5	2461 cm <sup>3</sup>	2V	120 kW	(163 PS)	18	95,50 mm

41 091 6.., 41 092 6..

IN [2] EX [2]	35,9 x 7 x 89,9 31,5 x 7 x 90,0	S - - A/S - -	- 45° - - - 45° - VS -	22 - III 22 - III	038 109 601 B 038 109 611 B 038 109 611 F	<b>331033</b> <b>331034</b>
[50]	Ø 7 mm				021 109 651	<b>MK-7H</b>
IN/EX [4]	12,08/15 x 7 x 36,5	B1			037 103 415 037 103 419 B	<b>81-33103</b>
IN/EX [4]	12,08/15 x 7 x 38,0	B1			027 103 419	<b>81-33100</b>
IN/EX [4]	12,25/15 x 7 x 36,5	B1				<b>81-33104</b>
					070 109 101M 070 109 101P	<b>50 007 577</b> (1)
(1) (ST)						
[8]	H 35 x 26 x 26				038 109 309 A 038 109 309 B 038 109 309 C	<b>50 006 418</b>

## 266 81

<b>BNZ</b>	04.2003 → 11.2009	D (LA)	5	2461 cm <sup>3</sup>	2V	96 kW	(130 PS)	18	95,50 mm
<b>BPC</b>	04.2003 → 11.2009	D (LA)	5	2461 cm <sup>3</sup>	2V	128 kW	(174 PS)	18	95,50 mm
<b>BPD</b>	08.2003 → 05.2010	D (LA)	5	2461 cm <sup>3</sup>	2V	120 kW	(163 PS)	18	95,50 mm
<b>BPE</b>	01.2003 → 05.2010	D (LA)	5	2461 cm <sup>3</sup>	2V	128 kW	(174 PS)	18	95,50 mm

41 093 6.., 41 094 6..

IN [2] EX [2]	36,0 x 7 x 89,5 31,5 x 7 x 89,0	S - - RA/S- -	- 45° - - - 45° - VS -	22 - III 22 - III	038 109 601 E 038 109 611 E	<b>331123</b> <b>331124</b>
[50]	Ø 7 mm				021 109 651	<b>MK-7H</b>
IN/EX [4]	12,08/15 x 7 x 36,5	B1			037 103 415 037 103 419 B	<b>81-33103</b>
IN/EX [4]	12,25/15 x 7 x 36,5	B1				<b>81-33104</b>
					070 109 101Q	<b>50 006 110</b> (1)
(1) (ST)						
[8]	H 35 x 26 x 26				038 109 309 A 038 109 309 B 038 109 309 C	<b>50 006 418</b>

					Reference	Item No.	
<b>267</b>		<b>81</b>					
<b>AZV</b>	02.2003 → 12.2013	D (LA)	4	1968 cm <sup>3</sup>	4V	100 kW (136 PS)	18 95,50 mm
<b>BKD</b>	08.2003 →	D (LA)	4	1968 cm <sup>3</sup>	4V	103 kW (140 PS)	18 95,50 mm
<b>BKP</b>	03.2005 → 11.2010	D (LA)	4	1968 cm <sup>3</sup>	4V	103 kW (140 PS)	18,5 95,50 mm
<b>BMA</b>	03.2005 → 11.2010	D (LA)	4	1968 cm <sup>3</sup>	4V	100 kW (136 PS)	18,5:1 95,50 mm
40 356 6.., 40 387 6..							
	IN [2]	29,2 x 6 x 87,8	S - -	- 45° - -	22 - III	03G 109 601B	<b>331121</b>
	IN [2]	29,4 x 6 x 88,5	S - -	- 45° - -	22 - III	03G 109 601A	<b>331119</b>
	EX [2]	25,5 x 6 x 87,5	RA/S- Cr -	- 45° - VS -	22 - III	03G 109 611D	<b>331122</b>
	EX [1]	25,5 x 6 x 88,2	RA/S- -	- 45° - VS -	22 - III	03G 109 611B	<b>331120</b>
	IN/EX [4]	10,06 x 6 x 42,0	B1				<b>81-33112</b>
		ES				03G 109 101 B	<b>50 007 575</b> (1)
		AS (1) (ST)				03G 109 101A 03G 109 102B	<b>50 007 576</b> (1)
	IN [4]					03G 109 411	<b>50 007 583</b> (2)
	IN [4]					03G109411B	<b>50 007 584</b> (3)
	EX [4]					03G 109 411 A	<b>50 006 179</b> (2)
	EX [4]					03G109411C	<b>50 007 585</b> (3)
	EX [4]					03G 109 412	<b>50 006 179</b> (2)
	EX [4]					03G109412B	<b>50 007 585</b> (3)
	EX [4]					03G 109 412 A	<b>50 007 585</b> (3)
	EX [4]					03G109412C	<b>50 007 585</b> (3)
	(2)	für Zylinder/for cylinder/pour cylindre/para cilindro/ля цилиндров 3+4					
	(3)	für Zylinder/for cylinder/pour cylindre/para cilindro/для цилиндров 1-2					
<b>268</b>		<b>81</b>					
<b>AXE Euro 3</b>	04.2003 → 11.2009	D (LA)	5	2461 cm <sup>3</sup>	2V	96-128 kW (131-174 PS)	18 95,50 mm
41 091 6.., 41 092 6..							
	IN [2]	35,9 x 7 x 89,9	S - -	- 45° - -	22 - III	038 109 601 B	<b>331033</b>
	EX [2]	31,5 x 7 x 90,0	A/S - -	- 45° - VS -	22 - III	038 109 611 B 038 109 611 F	<b>331034</b>
	[50]	Ø 7 mm				021 109 651	<b>MK-7H</b>
	IN/EX [4]	12,08/15 x 7 x 36,5	B1			037 103 415	<b>81-33103</b>
	IN/EX [4]	12,25/15 x 7 x 36,5	B1			037 103 419 B	<b>81-33104</b>
	(1) (ST)					070 109 101M 070 109 101P	<b>50 007 577</b> (1)
	[8]	H 35 x 26 x 26				038 109 309 A 038 109 309 B 038 109 309 C	<b>50 006 418</b>
<b>269</b>		<b>81</b>					
<b>BGW</b>	12.2003 → 05.2005	D (LA)	4	1968 cm <sup>3</sup>	2V	100 kW (136 PS)	18,5 95,50 mm
<b>BHW</b>	12.2003 → 05.2005	D (A)	4	1968 cm <sup>3</sup>	2V	100 kW (136 PS)	18,5 95,50 mm
40 408 6.., 40 409 6..							
	IN [2]	36,0 x 7 x 89,5	S - -	- 45° - -	22 - III	038 109 601 E	<b>331123</b>
	EX [2]	31,5 x 7 x 89,0	RA/S- -	- 45° - VS -	22 - III	038 109 611 E	<b>331124</b>
	[50]	Ø 7 mm				021 109 651	<b>MK-7H</b>
Fortsetzung nächste Seite / continued on next page / suite page suivante / continuación página próxima / Продолжение на следующей странице							

V

					Reference	Item No.
	IN/EX [4] 12,08/15 x 7 x 36,5	B1			037 103 415 037 103 419 B	<b>81-33103</b>
	IN/EX [4] 12,25/15 x 7 x 36,5	B1				<b>81-33104</b>
	(1) (ST)				038 109 101 AF	<b>50 006 343</b> (1)
	[8] H 35 x 26 x 26				038 109 309 A 038 109 309 B 038 109 309 C	<b>50 006 418</b>
	[1]  (2) Kipphebeleinheit - nicht voreingestellt! rocker shaft assembly - not preset! Unité culbuteur - n'est pas pré réglée! Unidad de balancines: no preajustada! Узел коромысла — без предварительной настройки!				038109527AF	<b>50 007 650</b> (2)
	- - G - S - - SB - -				038 103 351 D 03G 103 351 C 03G 103 351 D	<b>50 003 131</b>

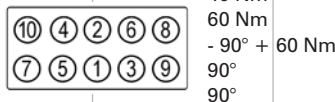

## 270

## 81

<b>BDJ</b>	03.2004 → 08.2010	D (NA)	4	1968 cm <sup>3</sup>	2V	51 kW	(70 PS)	19:1	95,50 mm
<b>BDK</b>	01.2004 → 11.2008	D (NA)	4	1968 cm <sup>3</sup>	2V	55 kW	(75 PS)	19:1	95,50 mm
<b>BST</b>	03.2004 → 08.2010	D (NA)	4	1968 cm <sup>3</sup>	2V	51 kW	(70 PS)	19	95,50 mm

	IN [2] 36,0 x 7 x 89,5	S - -	- 45° - -	22 - III	038 109 601 E	<b>331123</b>
	EX [2] 31,5 x 7 x 89,0	RA/S- -	- 45° - VS -	22 - III	038 109 611 E	<b>331124</b>
	[50] Ø 7 mm				021 109 651	<b>MK-7H</b>
	IN/EX [4] 12,08/15 x 7 x 36,5	B1			037 103 415 037 103 419 B	<b>81-33103</b>
	IN/EX [4] 12,25/15 x 7 x 36,5	B1				<b>81-33104</b>
	(1) (ST)				038 109 101 AE	<b>50 007 582</b> (1)
	[1]  (2) Kipphebeleinheit - nicht voreingestellt! rocker shaft assembly - not preset! Unité culbuteur - n'est pas pré réglée! Unidad de balancines: no preajustada! Узел коромысла — без предварительной настройки!				038109527AF	<b>50 007 650</b> (2)
	- - G - S - - SB - -				038 103 351 D 03G 103 351 C 03G 103 351 D	<b>50 003 131</b>

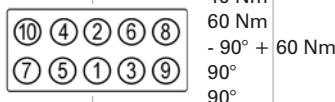

					Reference	Item No.	
<b>271</b>		<b>81</b>	<b>BMM</b>				
40 408 6.., 40 409 6..		12.2004 → 05.2011	D (LA)	4	1968 cm <sup>3</sup> 2V	103 kW (140 PS) 18,5	95,50 mm
	IN [2] EX [2]	36,0 x 7 x 89,5 31,5 x 7 x 89,0	S - - RA/S- -	- 45° - - - 45° - VS -	22 - III 22 - III	038 109 601 E 038 109 611 E	<b>331123</b> <b>331124</b>
	[50]	∅ 7 mm				021 109 651	<b>MK-7H</b>
	IN/EX [4]	12,07 x 7 x 31,5	B1				<b>81-33115</b> <small>NEW</small>
	(1) (ST)					038 109 101 AH	<b>50 006 342</b> (1)
	[8]	H 35 x 26 x 26				038 109 309 A 038 109 309 B 038 109 309 C	<b>50 006 418</b>
	[1]	(2) Kipphebeleinheit - nicht voreingestellt! rocker shaft assembly - not preset! Unité culbuteur - n'est pas pré-réglée! Unidad de balancines: no preajustada! Узел коромысла — без предварительной настройки!				038109527AF	<b>50 007 650</b> (2)
		- - G - S -	- SB - -			038 103 351 D 03G 103 351 C 03G 103 351 D	<b>50 003 131</b>
				 40 Nm 60 Nm - 90° + 60 Nm 90° 90°			

					Reference	Item No.		
<b>272</b>		<b>81</b>						
<b>CAAA Euro 5</b>	09.2009 →	D (LA)	4	1968 cm <sup>3</sup>	4V	62 kW (84 PS)	16,5	95,50 mm
<b>CAAB Euro 5</b>	09.2009 →	D (LA)	4	1968 cm <sup>3</sup>	4V	75 kW (102 PS)	16,5	95,50 mm
<b>CAAC Euro 5</b>	09.2009 →	D (LA)	4	1968 cm <sup>3</sup>	4V	103 kW (140 PS)	16,5	95,50 mm
<b>CAAD</b>	05.2011 → 08.2015	D (LA)	4	1968 cm <sup>3</sup>	4V	84 kW (114 PS)		95,50 mm
<b>CAAE</b>	05.2010 → 08.2015	D (A)	4	1968 cm <sup>3</sup>	4V	100 kW (136 PS)		95,50 mm
<b>CBAA</b>	03.2005 → 07.2018	D (LA)	4	1968 cm <sup>3</sup>	4V	100 kW (136 PS)	16,5	95,50 mm
<b>CBAB</b>	03.2005 → 07.2018	D (LA)	4	1968 cm <sup>3</sup>	4V	103 kW (140 PS)	16,5	95,50 mm
<b>CBBB</b>	08.2005 → 07.2018	D (LA)	4	1968 cm <sup>3</sup>	4V	125 kW (170 PS)	16,5	95,50 mm
<b>CBDA</b>	05.2005 → 12.2013	D (LA)	4	1968 cm <sup>3</sup>	4V	100 kW (136 PS)	16,5:1	95,50 mm
<b>CBDB</b>	01.2005 → 11.2017	D (LA)	4	1968 cm <sup>3</sup>	4V	103 kW (140 PS)	16,5:1	95,50 mm
<b>CCHA</b>	09.2009 → 08.2015	D (A)	4	1968 cm <sup>3</sup>	4V	103 kW (140 PS)		95,50 mm
<b>CCHB</b>	05.2010 → 08.2015	D (A)	4	1968 cm <sup>3</sup>	4V	100 kW (136 PS)		95,50 mm
<b>CDBA</b>	09.2010 → 10.2013	D (LA)	4	1968 cm <sup>3</sup>	4V	90 kW (122 PS)	16,5	95,50 mm
<b>CDCA</b>	09.2010 → 08.2012	D (LA)	4	1968 cm <sup>3</sup>	4V	120 kW (163 PS)	16,5	95,50 mm
<b>CEGA</b>	10.2006 →	D (A)	4	1968 cm <sup>3</sup>	4V	125 kW (170 PS)	16,5	95,50 mm
<b>CFFA</b>	11.2007 →	D (LA)	4	1968 cm <sup>3</sup>	4V	100 kW (136 PS)	16	95,50 mm
<b>CFFB</b>	09.2007 →	D (LA)	4	1968 cm <sup>3</sup>	4V	103 kW (140 PS)	16,5	95,50 mm
<b>CFFD</b>	05.2010 → 07.2018	D (LA)	4	1968 cm <sup>3</sup>	4V	81 kW (110 PS)		95,50 mm
<b>CFGB</b>	09.2007 →	D (LA)	4	1968 cm <sup>3</sup>	4V	125 kW (170 PS)	16,5	95,50 mm
<b>CFGC</b>	11.2012 → 07.2018	D (A)	4	1968 cm <sup>3</sup>	4V	130 kW (177 PS)	16	95,50 mm
<b>CFHC</b>	01.2005 →	D (LA)	4	1968 cm <sup>3</sup>	4V	103 kW (140 PS)	16,5:1	95,50 mm
<b>CFHE</b>	11.2010 →	D (LA)	4	1968 cm <sup>3</sup>	4V	62 kW (85 PS)	16,5	95,50 mm
<b>CFHF</b>	08.2010 → 09.2020	D (A)	4	1968 cm <sup>3</sup>	4V	81 kW (110 PS)	16,5:1	95,50 mm
<b>CFJA</b>	12.2005 →	D (A)	4	1968 cm <sup>3</sup>	4V	125 kW (170 PS)	16,5	95,50 mm
<b>CJAA</b>	08.2005 →	D (LA)	4	1968 cm <sup>3</sup>	4V	103-104 kW (140-141 PS)		95,50 mm
<b>CKTB</b>	05.2011 → 12.2016	D (LA)	4	1968 cm <sup>3</sup>	4V	80 kW (109 PS)	16	95,50 mm
<b>CKTC</b>	05.2011 → 12.2016	D (LA)	4	1968 cm <sup>3</sup>	4V	100 kW (136 PS)	16	95,50 mm
<b>CKUB</b>	07.2011 → 12.2016	D (LA)	4	1968 cm <sup>3</sup>	4V	120 kW (163 PS)	16	95,50 mm
<b>CKUC</b>	10.2011 → 12.2016	D (LA)	4	1968 cm <sup>3</sup>	4V	105 kW (142 PS)	16	95,50 mm
<b>CLCA</b>	10.2008 →	D (LA)	4	1968 cm <sup>3</sup>	4V	81 kW (110 PS)	16,5	95,50 mm
<b>CLCB</b>	11.2010 →	D (A)	4	1968 cm <sup>3</sup>	4V	103 kW (140 PS)	16,5	95,50 mm
<b>CLJA</b>	09.2007 → 07.2018	D (LA)	4	1968 cm <sup>3</sup>	4V	103 kW (140 PS)	18,5	95,50 mm
<b>CNEA</b>	09.2011 →	D (LA)	4	1968 cm <sup>3</sup>	4V	132 kW (180 PS)	16	95,50 mm
<b>CNFA</b>	09.2010 → 10.2013	D (LA)	4	1968 cm <sup>3</sup>	4V	90 kW (122 PS)	16	95,50 mm
<b>CNFB</b>	09.2011 → 10.2016	D (LA)	4	1968 cm <sup>3</sup>	4V	103 kW (140 PS)	16	95,50 mm
<b>CSHA</b>	09.2011 →	D (LA)	4	1968 cm <sup>3</sup>	4V	132 kW (180 PS)	16	95,50 mm

40 353 6...; 40 558 6..

	IN [2]	28,1 x 6 x 99,3	S - -	- 45° - -	22 - III	03L 109 601 04L 109 601B	<b>331131</b>
	EX [2]	26,0 x 6 x 99,1	RA/S- -	- 45° - VS -	22 - III	03L 109 611 04L 109 611B 04L 109 611C	<b>331132</b>
	[50]	∅ 6 mm				036 109 651A	<b>MK-6H</b>
	IN/EX [4]	10,06 x 6 x 42,0	B1				<b>81-33112</b>
		ES				03L 109 021 03L 109 021 D 03L 109 021 E	<b>50 007 020</b> <small>NEW</small> (1)
		AS				03L 109 022 03L 109 022 D	<b>50 007 022</b> <small>NEW</small> (1)
	(1)	Schalenhartguss/chilled cast iron/pièce moulée trempée en surface/fundición en coquilla/Отливка с отбелсным поверхностным слоем					
	[8]	H 12 x 32,5				03L 109 521 03L 109 521 A	<b>50 006 490</b>

Fortsetzung nächste Seite / continued on next page / suite page suivante / continuación página próxima / Продолжение на следующей странице



					Reference	Item No.
[4]					059 109 417 A 059 109 417 B 059 109 417 C 059 109 417 F 059 109 417 G 059109417J	<b>50 006 171</b>

<b>273</b>		<b>81</b>
<b>BMP</b>	03.2005 → 05.2009	D (LA) 4 1968 cm <sup>3</sup> 2V 103 kW (140 PS) 18,5 95,50 mm
<b>BVH</b>	11.2005 → 03.2010	D (LA) 4 1968 cm <sup>3</sup> 2V 100 kW (136 PS) 18,5 95,50 mm
40 408 6..., 40 409 6..		

	IN [2] EX [2]	36,0 x 7 x 89,5 31,5 x 7 x 89,0	S - - RA/S- -	- 45° - - - 45° - VS -	22 - III 22 - III	038 109 601 E 038 109 611 E	<b>331123</b> <b>331124</b>
	[50]	Ø 7 mm				021 109 651	<b>MK-7H</b>
	IN/EX [4] IN/EX [4]	12,08/15 x 7 x 36,5 12,25/15 x 7 x 36,5	B1 B1			037 103 415 037 103 419 B	<b>81-33103</b> <b>81-33104</b>
	(1) (ST)					038 109 101 AH	<b>50 006 342</b> (1)
	[8]	H 35 x 26 x 26				038 109 309 A 038 109 309 B 038 109 309 C	<b>50 006 418</b>
	[1]	(2) Kipphebeleinheit - nicht voreingestellt! rocker shaft assembly - not preset! Unité culbuteur - n'est pas pré réglée! Unidad de balancines: no preajustada! Узел коромысла — без предварительной настройки!				038109527AF	<b>50 007 650</b> (2)
		- - G - S -	- SB - -			038 103 351 D 03G 103 351 C 03G 103 351 D	<b>50 003 131</b>
					40 Nm 60 Nm - 90° + 60 Nm 90° 90°		

<b>274</b>		<b>81</b>
<b>CFHB</b>	05.2005 → 11.2017	D (LA) 4 1968 cm <sup>3</sup> 4V 100 kW (136 PS) 16,5:1 95,50 mm
40 353 6..		

	IN [2] EX [2]	28,1 x 6 x 99,3 26,0 x 6 x 99,1	S - - RA/S- -	- 45° - - - 45° - VS -	22 - III 22 - III	03L 109 601 04L 109 601B 03L 109 611 04L 109 611B 04L 109 611C	<b>331131</b> <b>331132</b>
	[50]	Ø 6 mm				036 109 651A	<b>MK-6H</b>
	IN/EX [4]	10,06 x 6 x 42,0	B1				<b>81-33112</b>
	ES					03L 109 021 03L 109 021 D 03L 109 021 E	<b>50 007 020</b> <b>NEW</b> (1)
Fortsetzung nächste Seite / continued on next page / suite page suivante / continuación página próxima / Продолжение на следующей странице							

					Reference	Item No.
(1)	Schalenhartguss/chilled cast iron/pièce moulée trempée en surface/fundición en coquilla/Отливка с отбелнным поверхностным слоем					
[8]	H	12 x 32,5			03L 109 521 03L 109 521 A	<b>50 006 490</b>
[4]					059 109 417 A 059 109 417 B 059 109 417 C 059 109 417 F 059 109 417 G 059109417J	<b>50 006 171</b>

## 275

81

**BVE** 08.2005 → 07.2006 D (LA) 4 1968 cm<sup>3</sup> 4V 90 kW (122 PS) 18:1 95,50 mm  
40 387 6..

	IN [2]	29,2 x 6 x 87,8	S - -	- 45° - -	22 - III	03G 109 601B	<b>331121</b>	
	IN [2]	29,4 x 6 x 88,5	S - -	- 45° - -	22 - III	03G 109 601A	<b>331119</b>	
	EX [2]	25,5 x 6 x 87,5	RA/S- Cr -	- 45° - VS -	22 - III	03G 109 611D	<b>331122</b>	
	EX [1]	25,5 x 6 x 88,2	RA/S- -	- 45° - VS -	22 - III	03G 109 611B	<b>331120</b>	
	IN/EX [4]	10,06 x 6 x 42,0	B1				<b>81-33112</b>	
		AS				03G 109 102B	<b>50 007 576</b> (1)	
	(1) (ST)							
	IN [4]					03G 109 411 03G109411B	<b>50 007 583</b> (2)	
	IN [4]					03G 109 411 A 03G109411C	<b>50 007 584</b> (3)	
	EX [4]					03G 109 412 03G109412B	<b>50 006 179</b> (2)	
	EX [4]					03G 109 412 A 03G109412C	<b>50 007 585</b> (3)	
	(2)	für Zylinder/for cylinder/pour cylindre/para cilindro/ля цилиндров 3+4						
	(3)	für Zylinder/for cylinder/pour cylindre/para cilindro/для цилиндров 1-2						

## 276

81

**BMN** 11.2005 → 10.2010 D (LA) 4 1968 cm<sup>3</sup> 4V 125 kW (170 PS) 18,5 95,50 mm  
**BUZ** 08.2005 → 05.2009 D (LA) 4 1968 cm<sup>3</sup> 4V 120 kW (163 PS) 18,5 95,50 mm  
40 387 6..

	IN [2]	29,2 x 6 x 87,8	S - -	- 45° - -	22 - III	03G 109 601B	<b>331121</b>
	IN [2]	29,4 x 6 x 88,5	S - -	- 45° - -	22 - III	03G 109 601A	<b>331119</b>
	EX [2]	25,5 x 6 x 87,5	RA/S- Cr -	- 45° - VS -	22 - III	03G 109 611D	<b>331122</b>
	EX [1]	25,5 x 6 x 88,2	RA/S- -	- 45° - VS -	22 - III	03G 109 611B	<b>331120</b>
	IN/EX [4]	10,06 x 6 x 42,0	B1				<b>81-33112</b>
		ES				03G 109 101 B 03G 109 101A	<b>50 007 575</b> (1)
		AS				03G 109 102 F	<b>50 007 578</b> (1)
	(1) (ST)						

Fortsetzung nächste Seite / continued on next page / suite page suivante / continuación página próxima / Продолжение на следующей странице

					Reference	Item No.
IN [4]					03G 109 411 03G109411B	<b>50 007 583</b> (2)
IN [4]					03G 109 411 A 03G109411C	<b>50 007 584</b> (3)
EX [4]					03G 109 412 03G109412B	<b>50 006 179</b> (2)
EX [4]					03G 109 412 A 03G109412C	<b>50 007 585</b> (3)
	(2) für Zylinder/for cylinder/pour cylindre/para cilindro/ля цилиндров 3+4					
	(3) für Zylinder/for cylinder/pour cylindre/para cilindro/для цилиндров 1-2					

**277**
**81**

**BMR** 08.2005 → 11.2010 D (LA) 4 1968 cm<sup>3</sup> 4V 125 kW (170 PS) 18:1 95,50 mm  
40 387 6..

IN [2]	29,2 x 6 x 87,8	S - -	- 45° - -	22 - III	03G 109 601B	<b>331121</b>
IN [2]	29,4 x 6 x 88,5	S - -	- 45° - -	22 - III	03G 109 601A	<b>331119</b>
EX [2]	25,5 x 6 x 87,5	RA/S- Cr -	- 45° - VS -	22 - III	03G 109 611D	<b>331122</b>
EX [1]	25,5 x 6 x 88,2	RA/S- -	- 45° - VS -	22 - III	03G 109 611B	<b>331120</b>
IN/EX [4]	10,06 x 6 x 42,0	B1				<b>81-33112</b>
IN/EX [4]	11,04 x 6 x 39,0	B1				<b>81-33121</b>
EX [4]	11,04 x 6 x 39,0	G2				<b>81-33122</b>
ES					03G 109 101 B	<b>50 007 575</b> (1)
AS					03G 109 101A	
(1) (ST)					03G 109 102 F	<b>50 007 578</b> (1)
IN [4]					03G 109 411 03G109411B	<b>50 007 583</b> (2)
IN [4]					03G 109 411 A 03G109411C	<b>50 007 584</b> (3)
EX [4]					03G 109 412 03G109412B	<b>50 006 179</b> (2)
EX [4]					03G 109 412 A 03G109412C	<b>50 007 585</b> (3)
	(2) für Zylinder/for cylinder/pour cylindre/para cilindro/ля цилиндров 3+4					
	(3) für Zylinder/for cylinder/pour cylindre/para cilindro/для цилиндров 1-2					

**278**
**81**

<b>CBAC</b>	01.2009 → 11.2010	D (LA)	4	1968 cm <sup>3</sup>	4V	105 kW	(143 PS)	16,5	95,50 mm
<b>CBBA</b>	02.2008 → 05.2011	D (LA)	4	1968 cm <sup>3</sup>	4V	120 kW	(163 PS)	18,5:1	95,50 mm
<b>CBDC</b>	10.2008 → 12.2013	D (LA)	4	1968 cm <sup>3</sup>	4V	81 kW	(110 PS)	16,5:1	95,50 mm
<b>CBEA</b>	08.2005 → 10.2010	D (LA)	4	1968 cm <sup>3</sup>	4V	103 kW	(140 PS)	18	95,50 mm
<b>CFJB</b>	01.2013 → 05.2015	D (A)	4	1968 cm <sup>3</sup>	4V	130 kW	(177 PS)	16	95,50 mm
<b>CKFC Euro 5</b>	11.2012 →	D (LA)	4	1968 cm <sup>3</sup>	4V	110 kW	(150 PS)	16	95,50 mm
<b>CKRA Euro 6</b>	04.2011 → 06.2015	D (LA)	4	1968 cm <sup>3</sup>	4V	103 kW	(140 PS)	16,5	95,50 mm
<b>CRBC Euro 5</b>	11.2012 →	D (LA)	4	1968 cm <sup>3</sup>	4V	110 kW	(150 PS)	16,2	95,50 mm
<b>CRLB Euro 6</b>	11.2012 →	D (LA)	4	1968 cm <sup>3</sup>	4V	110 kW	(150 PS)	16,2	95,50 mm
<b>CRMB Euro 6</b>	11.2012 →	D (LA)	4	1968 cm <sup>3</sup>	4V	110 kW	(150 PS)	16,2	95,50 mm
<b>CRVA Euro 4</b>	11.2012 → 07.2019	D (LA)	4	1968 cm <sup>3</sup>	4V	81 kW	(110 PS)	16,2	95,50 mm
<b>CUNA Euro 6</b>	04.2013 →	D (LA)	4	1968 cm <sup>3</sup>	4V	135 kW	(184 PS)	15,8	95,50 mm

40 353 6.., 40 558 6.., 41 270 6.., 41 661 6..

IN [2]	28,1 x 6 x 99,3	S - -	- 45° - -	22 - III	03L 109 601 04L 109 601B	<b>331131</b>
EX [2]	26,0 x 6 x 99,1	RA/S- -	- 45° - VS -	22 - III	03L 109 611 04L 109 611B 04L 109 611C	<b>331132</b>
[50]	Ø 6 mm				036 109 651A	<b>MK-6H</b>

Fortsetzung nächste Seite / continued on next page / suite page suivante / continuación página próxima / Продолжение на следующей странице

					Reference	Item No.
	IN/EX [4] 10,06 x 6 x 42,0	B1				<b>81-33112</b>
	[8] H 12 x 32,5				03L 109 521 03L 109 521 A	<b>50 006 490</b>
	[4]				059 109 417 A 059 109 417 B 059 109 417 C 059 109 417 F 059 109 417 G 059109417J	<b>50 006 171</b>

**279**
**81**
**BWV** 11.2005 → 05.2007 D (LA) 4 1968 cm<sup>3</sup> 4V 88 kW (120 PS) 18,5 95,50 mm  
 40 387 6..

	IN [2] 29,2 x 6 x 87,8	S - -	- 45° - -	22 - III	03G 109 601B	<b>331121</b>
	IN [2] 29,4 x 6 x 88,5	S - -	- 45° - -	22 - III	03G 109 601A	<b>331119</b>
	EX [2] 25,5 x 6 x 87,5	RA/S- Cr -	- 45° - VS -	22 - III	03G 109 611D	<b>331122</b>
	EX [1] 25,5 x 6 x 88,2	RA/S- -	- 45° - VS -	22 - III	03G 109 611B	<b>331120</b>
	IN/EX [4] 10,06 x 6 x 42,0	B1				<b>81-33112</b>
	IN [4]				03G 109 411 03G109411B	<b>50 007 583</b> (1)
	IN [4]				03G 109 411 A 03G109411C	<b>50 007 584</b> (2)
	EX [4]				03G 109 412 03G109412B	<b>50 006 179</b> (1)
	EX [4]				03G 109 412 A 03G109412C	<b>50 007 585</b> (2)
	(1) für Zylinder/for cylinder/pour cylindre/para cilindro/ля цилиндров 3+4					
	(2) für Zylinder/for cylinder/pour cylindre/para cilindro/для цилиндров 1-2					

**280**
**81**
**BRT** 11.2005 → 03.2010 D (LA) 4 1968 cm<sup>3</sup> 2V 103 kW (140 PS) 18,5 95,50 mm  
 40 408 6..., 40 409 6..

	IN [2] 36,0 x 7 x 89,5	S - -	- 45° - -	22 - III	038 109 601 E	<b>331123</b>
	EX [2] 31,5 x 7 x 89,0	RA/S- -	- 45° - VS -	22 - III	038 109 611 E	<b>331124</b>
	[50] Ø 7 mm				021 109 651	<b>MK-7H</b>
	IN/EX [4] 12,07 x 7 x 31,5	B1				<b>81-33115</b> <sup>NEW</sup>
	IN/EX [4] 12,08/15 x 7 x 36,5	B1			037 103 415 037 103 419 B	<b>81-33103</b>
	IN/EX [4] 12,25/15 x 7 x 36,5	B1				<b>81-33104</b>
	(1) (ST)				038 109 101 AH	<b>50 006 342</b> (1)
	[8] H 35 x 26 x 26				038 109 309 A 038 109 309 B 038 109 309 C	<b>50 006 418</b>
	[1]				038109527AF	<b>50 007 650</b> (2)

Fortsetzung nächste Seite / continued on next page / suite page suivante / continuación página próxima / Продолжение на следующей странице

					Reference	Item No.
(2)	Kipphebeleinheit - nicht voreingestellt! rocker shaft assembly - not preset! Unité culbuteur - n'est pas pré réglée! Unidad de balancines: no preajustada! Узел коромысла — без предварительной настройки!					
	- - G - S -	- SB - -			038 103 351 D 03G 103 351 C 03G 103 351 D	<b>50 003 131</b>
					40 Nm 60 Nm - 90° + 60 Nm 90° 90°	

## 281

### 81

<b>BJJ</b>	04.2006 → 07.2011	D (LA)	5	2461 cm <sup>3</sup>	2V	65 kW	(88 PS)	95,50 mm
<b>BJK</b>	04.2006 → 05.2013	D (LA)	5	2461 cm <sup>3</sup>	2V	80 kW	(109 PS)	95,50 mm
<b>BJL</b>	04.2006 → 05.2013	D (LA)	5	2461 cm <sup>3</sup>	2V	100 kW	(136 PS)	95,50 mm
<b>BJM</b>	04.2006 → 07.2011	D (LA)	5	2461 cm <sup>3</sup>	2V	120 kW	(163 PS)	95,50 mm

40 683 6.., 40 715 6..

	IN [2]	36,0 x 8 x 96,9	RA/S-	-	- 45° - VS -	22 - III	028 109 601 H 028 109 601A 046 109 601G 046 109 601J 049 109 601J	<b>39423</b>	(1)
	EX [2]	31,6 x 8 x 96,9	RA/S-	-	- 45° - -	22 - III	046 109 611 C 046 109 611 E 046 109 611 F	<b>331142</b>	
	(1)	OES specification							
	[50]	∅ 8 mm					113 109 651 A 400 501 068	<b>MK-8H</b>	
	IN/EX [4]	12,06/15 x 8 x 36,5	B1				056 103 419 A	<b>81-3310</b>	
	IN/EX [4]	12,13/15 x 8 x 36,5	B1					<b>81-3312</b>	
	IN/EX [4]	12,20/15 x 8 x 36,5	B1					<b>81-3311</b>	
	(2)	Schalenhartguss/chilled cast iron/pièce moulée trempée en surface/fundición en coquilla/Отливка с отбеленным поверхностным слоем							
	[8]	H 35 x 26 x 26					034 109 309 034 109 309 AC 034 109 309 AD 034 109 309 N 074 109 309	<b>50 006 460</b>	

## 282

### 81

<b>CEBA</b>	04.2006 → 07.2011	D (LA)	5	2461 cm <sup>3</sup>	2V	65 kW	(88 PS)	16,8:1	95,50 mm
<b>CEBB</b>	04.2006 → 05.2013	D (LA)	5	2461 cm <sup>3</sup>	2V	80 kW	(109 PS)	16,8:1	95,50 mm
<b>CECB</b>	04.2006 → 07.2011	D (LA)	5	2461 cm <sup>3</sup>	2V	120 kW	(163 PS)	16,8:1	95,50 mm

40 683 6.., 40 715 6..

	IN [2]	36,0 x 8 x 96,9	RA/S-	-	- 45° - VS -	22 - III	028 109 601 H 028 109 601A 046 109 601G 046 109 601J 049 109 601J	<b>39423</b>	(1)
	EX [2]	31,6 x 8 x 96,9	RA/S-	-	- 45° - -	22 - III	046 109 611 C 046 109 611 E 046 109 611 F	<b>331142</b>	
	(1)	OES specification							

Fortsetzung nächste Seite / continued on next page / suite page suivante / continuación página próxima / Продолжение на следующей странице

					Reference	Item No.
[50]	Ø 8 mm				113 109 651 A 400 501 068	<b>MK-8H</b>
IN/EX [4]	12,06/15 x 8 x 36,5	B1			056 103 419 A	<b>81-3310</b>
IN/EX [4]	12,13/15 x 8 x 36,5	B1				<b>81-3312</b>
IN/EX [4]	12,20/15 x 8 x 36,5	B1				<b>81-3311</b>
<b>283</b>	<b>81</b>					
<b>CECA</b> 40 683 6..	04.2006 → 05.2013	D (LA)	5	2461 cm <sup>3</sup> 2V	100 kW (136 PS)	16,8:1 95,50 mm
IN [2]	36,0 x 8 x 96,9	RA/S- -	- 45° - VS -	22 - III	028 109 601 H 028 109 601A 046 109 601G 046 109 601J 049 109 601J	<b>39423</b> (1)
EX [2]	31,6 x 8 x 96,9	RA/S- -	- 45° - -	22 - III	046 109 611 C 046 109 611 E 046 109 611 F	<b>331142</b>
	(1) OES specification					
[50]	Ø 8 mm				113 109 651 A 400 501 068	<b>MK-8H</b>
IN/EX [4]	12,06/15 x 8 x 36,5	B1			056 103 419 A	<b>81-3310</b>
IN/EX [4]	12,13/15 x 8 x 36,5	B1				<b>81-3312</b>
IN/EX [4]	12,20/15 x 8 x 36,5	B1				<b>81-3311</b>
[8]	H 35 x 26 x 26				034 109 309 034 109 309 AC 034 109 309 AD 034 109 309 N 074 109 309	<b>50 006 460</b>
<b>284</b>	<b>81</b>					
<b>CBHA</b>	05.2007 →	D (A)	4	1968 cm <sup>3</sup> 2V	47 kW (64 PS)	95,50 mm
<b>CBJA</b>	05.2007 →	D (LA)	4	1968 cm <sup>3</sup> 2V	55 kW (75 PS)	95,50 mm
<b>CBJB</b>		D (A)	4	1968 cm <sup>3</sup> 2V	55 kW (75 PS)	95,50 mm
40 408 6.., 40 409 6..						
IN [2]	36,0 x 7 x 89,5	S - -	- 45° - -	22 - III	038 109 601 E	<b>331123</b>
EX [2]	31,5 x 7 x 89,0	RA/S- -	- 45° - VS -	22 - III	038 109 611 E	<b>331124</b>
[50]	Ø 7 mm				021 109 651	<b>MK-7H</b>
IN/EX [4]	12,08/15 x 7 x 36,5	B1			037 103 415 037 103 419 B	<b>81-33103</b>
IN/EX [4]	12,25/15 x 7 x 36,5	B1				<b>81-33104</b>
<b>285</b>	<b>81</b>					
<b>CBKA</b>	05.2007 →	D (A)	4	1968 cm <sup>3</sup> 2V	74 kW (101 PS)	95,50 mm
40 408 6.., 40 409 6..						
IN [2]	36,0 x 7 x 89,5	S - -	- 45° - -	22 - III	038 109 601 E	<b>331123</b>
EX [2]	31,5 x 7 x 89,0	RA/S- -	- 45° - VS -	22 - III	038 109 611 E	<b>331124</b>
[50]	Ø 7 mm				021 109 651	<b>MK-7H</b>
IN/EX [4]	12,08/15 x 7 x 36,5	B1			037 103 415 037 103 419 B	<b>81-33103</b>
IN/EX [4]	12,25/15 x 7 x 36,5	B1				<b>81-33104</b>
Fortsetzung nächste Seite / continued on next page / suite page suivante / continuación página próxima / Продолжение на следующей странице						



					Reference	Item No.	
	- - G - S -	- SB - -			038 103 351 D 03G 103 351 C 03G 103 351 D	<b>50 003 131</b>	
				40 Nm 60 Nm - 90° + 60 Nm 90° 90°			
<b>286</b>		<b>81</b>					
<b>BVB</b>	06.2007 → 07.2009	D (LA)	4	1968 cm <sup>3</sup>	4V	96 kW (131 PS) 18:1	95,50 mm
	[8]	H 35 x 26 x 26				038 109 309 A 038 109 309 B 038 109 309 C	<b>50 006 418</b>
	[1]					038109527AF	<b>50 007 650</b> (1)
		(1) Kipphebeleinheit - nicht voreingestellt! rocker shaft assembly - not preset! Unité culbuteur - n'est pas pré réglée! Unidad de balancines: no preajustada! Узел коромысла — без предварительной настройки!					
<b>287</b>		<b>81</b>					
<b>CFFE</b>	05.2011 → 07.2019	D (LA)	4	1968 cm <sup>3</sup>	4V	85 kW (115 PS) 16,5	95,50 mm
<b>CLLA</b>	06.2008 → 12.2016	D (LA)	4	1968 cm <sup>3</sup>	4V	125 kW (170 PS)	95,50 mm
40 353 6..							
	IN [2]	28,1 x 6 x 99,3	S - -	- 45° - -	22 - III	03L 109 601 04L 109 601B	<b>331131</b>
	EX [2]	26,0 x 6 x 99,1	RA/S- -	- 45° - VS -	22 - III	03L 109 611 04L 109 611B 04L 109 611C	<b>331132</b>
	[50]	∅ 6 mm				036 109 651A	<b>MK-6H</b>
	IN/EX [4]	10,06 x 6 x 42,0	B1				<b>81-33112</b>
		ES				03L 109 021 03L 109 021 D 03L 109 021 E	<b>50 007 020</b> (1)
		AS				03L 109 022 03L 109 022 D	<b>50 007 022</b> (1)
		(1) Schalenhartguss/chilled cast iron/pièce moulée trempée en surface/fundición en coquilla/Отливка с отбеленным поверхностным слоем					
<b>288</b>		<b>81</b>					
<b>CFCA Euro 5</b>	09.2009 →	D (LA)	4	1968 cm <sup>3</sup>	4V	132 kW (180 PS) 16,5	95,50 mm
40 558 6..							
	IN [2]	28,1 x 6 x 99,3	S - -	- 45° - -	22 - III	03L 109 601 04L 109 601B	<b>331131</b>
	EX [2]	26,0 x 6 x 99,1	RA/S- -	- 45° - VS -	22 - III	03L 109 611 04L 109 611B 04L 109 611C	<b>331132</b>
	[50]	∅ 6 mm				036 109 651A	<b>MK-6H</b>
	IN/EX [4]	10,06 x 6 x 36,0	B1				<b>81-33116</b>
	IN/EX [4]	10,06 x 6 x 42,0	B1				<b>81-33112</b>
	IN/EX [4]	10,21 x 6 x 36,0	B1				<b>81-33117</b>
Fortsetzung nächste Seite / continued on next page / suite page suivante / continuación página próxima / Продолжение на следующей странице							

V

					Reference	Item No.
	ES				03L 109 021 03L 109 021 D 03L 109 021 E	<b>50 007 020</b> <small>NEW</small> (1)
	AS				03L 109 022 03L 109 022 D	<b>50 007 022</b> <small>NEW</small> (1)
	(1) Schalenhartguss/chilled cast iron/pièce moulée trempée en surface/fundición en coquilla/Отливка с отбеленным поверхностным слоем					
	[8] H 12 x 32,5				03L 109 521 03L 109 521 A	<b>50 006 490</b>
	[4]				059 109 417 A 059 109 417 B 059 109 417 C 059 109 417 F 059 109 417 G 059109417J	<b>50 006 171</b>

## 289 81

<b>CRFD Euro 4</b>	06.2016 → 07.2020	D (LA)	4	1968 cm <sup>3</sup>	4V	105 kW	(143 PS)	16,2	95,50 mm
<b>CRGA Euro 4</b>	05.2016 →	D (LA)	4	1968 cm <sup>3</sup>	4V	130 kW	(177 PS)	15,5-16,2	95,50 mm
<b>CRGB Euro 4</b>	08.2016 → 07.2020	D (LA)	4	1968 cm <sup>3</sup>	4V	130 kW	(177 PS)	16,2	95,50 mm
<b>CRLD Euro 6</b>	11.2015 → 11.2017	D (LA)	4	1968 cm <sup>3</sup>	4V	81 kW	(110 PS)	16,2	95,50 mm
<b>CSLA</b>	05.2011 → 12.2016	D (LA)	4	1968 cm <sup>3</sup>	4V	80 kW	(109 PS)	15,5	95,50 mm
<b>CSLB</b>	11.2013 → 12.2016	D (LA)	4	1968 cm <sup>3</sup>	4V	84 kW	(114 PS)	15,5	95,50 mm
<b>CSLC</b>	11.2015 → 12.2016	D (LA)	4	1968 cm <sup>3</sup>	4V	103 kW	(140 PS)	15,5	95,50 mm
<b>CSNA</b>	07.2011 → 12.2016	D (LA)	4	1968 cm <sup>3</sup>	4V	120 kW	(163 PS)	15,5	95,50 mm
<b>CUUA</b>	11.2013 → 09.2018	D (A)	4	1968 cm <sup>3</sup>	4V	81 kW	(110 PS)		95,50 mm
<b>CUUB</b>	11.2013 →	D (A)	4	1968 cm <sup>3</sup>	4V	110 kW	(150 PS)	16,2	95,50 mm
<b>CUUC</b>		D (A)	4	1968 cm <sup>3</sup>	4V	55 kW	(75 PS)	16,2	95,50 mm
<b>CUUD</b>	05.2015 →	D (A)	4	1968 cm <sup>3</sup>	4V	75 kW	(102 PS)		95,50 mm
<b>CUUE</b>	05.2015 →	D (A)	4	1968 cm <sup>3</sup>	4V	90 kW	(122 PS)		95,50 mm
<b>CUUF</b>	05.2015 →	D (A)	4	1968 cm <sup>3</sup>	4V	55 kW	(75 PS)		95,50 mm
<b>CUVA Euro 6</b>	05.2011 → 07.2019	D (LA)	4	1968 cm <sup>3</sup>	4V	85 kW	(115 PS)	16,2	95,50 mm
<b>CUVC Euro 6</b>	05.2015 →	D (LA)	4	1968 cm <sup>3</sup>	4V	110 kW	(150 PS)	16,2	95,50 mm
<b>CYKA</b>		D (A)	4	1968 cm <sup>3</sup>	4V	110 kW	(150 PS)		95,50 mm
<b>CYKB Euro 5</b>	11.2014 → 07.2019	D (LA)	4	1968 cm <sup>3</sup>	4V	81 kW	(110 PS)	16,2	95,50 mm
<b>CYKC Euro 5</b>	08.2016 → 07.2020	D (LA)	4	1968 cm <sup>3</sup>	4V	81 kW	(110 PS)	16,2	95,50 mm
<b>DBGA Euro 5</b>	11.2014 →	D (LA)	4	1968 cm <sup>3</sup>	4V	110 kW	(150 PS)	16,2	95,50 mm
<b>DBGB</b>	05.2016 → 05.2017	D (LA)	4	1968 cm <sup>3</sup>	4V	81 kW	(110 PS)	16,2	95,50 mm
<b>DBG Euro 5</b>	01.2016 →	D (A)	4	1968 cm <sup>3</sup>	4V	110 kW	(150 PS)	16,2	95,50 mm
<b>DCYA Euro 6</b>	11.2012 →	D (LA)	4	1968 cm <sup>3</sup>	4V	110 kW	(150 PS)	16,2	95,50 mm
<b>DCYB Euro 6</b>	11.2016 → 07.2018	D (A)	4	1968 cm <sup>3</sup>	4V	81 kW	(110 PS)	16,2	95,50 mm
<b>DFCA</b>	11.2014 →	D (A)	4	1968 cm <sup>3</sup>	4V	140 kW	(190 PS)	15,5	95,50 mm
<b>DFEA Euro 6</b>	08.2014 →	D (LA)	4	1968 cm <sup>3</sup>	4V	110 kW	(150 PS)	16,2	95,50 mm
<b>DFEB Euro 6</b>	02.2016 → 05.2016	D (LA)	4	1968 cm <sup>3</sup>	4V	81 kW	(110 PS)	16,2	95,50 mm
<b>DFGA Euro 6</b>	11.2012 →	D (LA)	4	1968 cm <sup>3</sup>	4V	110 kW	(150 PS)	16,2	95,50 mm
<b>DFGB Euro 6</b>	05.2016 →	D (LA)	4	1968 cm <sup>3</sup>	4V	81 kW	(110 PS)	16	95,50 mm
<b>DFGC Euro 6</b>	05.2016 →	D (LA)	4	1968 cm <sup>3</sup>	4V	85 kW	(115 PS)	16,2	95,50 mm
<b>DFHA Euro 6</b>	11.2014 →	D (LA)	4	1968 cm <sup>3</sup>	4V	140 kW	(190 PS)	15,5-16,2	95,50 mm
<b>DFSB</b>	05.2015 →	D (A)	4	1968 cm <sup>3</sup>	4V	110 kW	(150 PS)		95,50 mm
<b>DFSC</b>	11.2015 → 07.2019	D (A)	4	1968 cm <sup>3</sup>	4V	55 kW	(75 PS)		95,50 mm
<b>DFSD</b>	05.2015 →	D (A)	4	1968 cm <sup>3</sup>	4V	75 kW	(102 PS)		95,50 mm
<b>DFSE</b>	05.2015 →	D (A)	4	1968 cm <sup>3</sup>	4V	90 kW	(122 PS)		95,50 mm
<b>DFSF</b>	05.2015 →	D (A)	4	1968 cm <sup>3</sup>	4V	55 kW	(75 PS)		95,50 mm

40 353 6..., 41 270 6..., 41 647 6..., 41 661 6..., 41 936 6..., 41 937 6...

	IN [2]	28,1 x 6 x 99,3	S - -	- 45° - -	22 - III	03L 109 601 04L 109 601B	<b>331131</b>
	EX [2]	26,0 x 6 x 99,1	RA/S- -	- 45° - VS -	22 - III	03L 109 611 04L 109 611B 04L 109 611C	<b>331132</b>
	[50]	Ø 6 mm				036 109 651A	<b>MK-6H</b>

Fortsetzung nächste Seite / continued on next page / suite page suivante / continuación página próxima / Продолжение на следующей странице

					Reference	Item No.		
	IN/EX [4] 10,06 x 6 x 42,0	B1				<b>81-33112</b>		
<b>290</b>		<b>81</b>						
<b>CRVC Euro 4</b>	08.2012 →	D (LA)	4	1968 cm <sup>3</sup>	4V	105 kW (143 PS)	16 95,50 mm	
41 270 6..								
	IN [2] 28,1 x 6 x 99,3	S - -	- 45° -	-	22 - III	03L 109 601 04L 109 601B	<b>331131</b>	
	EX [2] 26,0 x 6 x 99,1	RA/S- -	- 45° -	VS -	22 - III	03L 109 611 04L 109 611B 04L 109 611C	<b>331132</b>	
	[50]	Ø 6 mm					036 109 651A	<b>MK-6H</b>
	IN/EX [4] 10,06 x 6 x 42,0	B1					<b>81-33112</b>	
	IN/EX [4] 11,05 x 6 x 40,5	B1					<b>81-51000</b>	
	IN/EX [4] 11,25/8.8 x 6 x 40,5	B1					<b>81-51001</b>	
	[8]	H 12 x 32,5					03L 109 521 03L 109 521 A	<b>50 006 490</b>
	[4]						059 109 417 A 059 109 417 B 059 109 417 C 059 109 417 F 059 109 417 G 059109417J	<b>50 006 171</b>
<b>291</b>		<b>81</b>						
<b>DDAA Euro 6</b>	11.2014 →	D (A)	4	1968 cm <sup>3</sup>	4V	140 kW (190 PS)	15,8 95,50 mm	
<b>DGCA Euro 6</b>	04.2013 →	D (LA)	4	1968 cm <sup>3</sup>	4V	135 kW (184 PS)	16,2 95,50 mm	
<b>DJGA Euro 6</b>	04.2013 →	D (LA)	4	1968 cm <sup>3</sup>	4V	135 kW (184 PS)	95,50 mm	
41 647 6..								
	IN [2] 28,1 x 6 x 99,3	S - -	- 45° -	-	22 - III	03L 109 601 04L 109 601B	<b>331131</b>	
	EX [2] 26,0 x 6 x 99,1	RA/S- -	- 45° -	VS -	22 - III	03L 109 611 04L 109 611B 04L 109 611C	<b>331132</b>	
	[50]	Ø 6 mm					036 109 651A	<b>MK-6H</b>
<b>292</b>		<b>81</b>						
<b>CXEB Euro 6</b>	06.2015 →	D (LA)	4	1968 cm <sup>3</sup>	4V	150 kW (204 PS)	15,5 95,50 mm	
<b>CXEC Euro 6</b>	08.2018 →	D (LA)	4	1968 cm <sup>3</sup>	4V	146 kW (199 PS)	15,5 95,50 mm	
<b>CXFA Euro 6</b>	04.2015 →	D (LA)	4	1968 cm <sup>3</sup>	4V	110 kW (150 PS)	15,5 95,50 mm	
<b>CXGA Euro 6</b>	04.2015 →	D (LA)	4	1968 cm <sup>3</sup>	4V	62 kW (84 PS)	15,5 95,50 mm	
<b>CXGB Euro 6</b>	04.2015 →	D (LA)	4	1968 cm <sup>3</sup>	4V	75 kW (102 PS)	95,50 mm	
<b>CXGD Euro 6</b>	10.2019 →	D (LA)	4	1968 cm <sup>3</sup>	4V	66 kW (90 PS)	95,50 mm	
<b>CXHA Euro 6</b>	04.2015 →	D (LA)	4	1968 cm <sup>3</sup>	4V	110 kW (150 PS)	15,5 95,50 mm	
<b>CXHB Euro 6</b>	05.2016 →	D (LA)	4	1968 cm <sup>3</sup>	4V	84 kW (114 PS)	95,50 mm	
<b>CXHC Euro 6</b>	07.2019 →	D (LA)	4	1968 cm <sup>3</sup>	4V	81 kW (110 PS)	95,50 mm	
<b>DAUA</b>	09.2016 →	D (A)	4	1968 cm <sup>3</sup>	4V	103 kW (140 PS)	95,50 mm	
<b>DAUB</b>	10.2016 →	D (A)	4	1968 cm <sup>3</sup>	4V	75 kW (102 PS)	95,50 mm	
<b>DAVA</b>	09.2016 →	D (LA)	4	1968 cm <sup>3</sup>	4V	130 kW (177 PS)	95,50 mm	
<b>DSRA Euro 6</b>	11.2014 →	D (LA)	4	1968 cm <sup>3</sup>	4V	110 kW (150 PS)	95,50 mm	
<b>DSRB Euro 6</b>	11.2014 →	D (LA)	4	1968 cm <sup>3</sup>	4V	110 kW (150 PS)	95,50 mm	
41 785 6..								
	IN [2] 28,1 x 5 x 99,3	S - -	- 45° -	Y -	22 - III	04L 109 601 H	<b>331165</b>	
	EX [2] 25,0 x 5 x 99,3	RA/S- -	- 45° -	VS -	22 - III	04L 106 611 04L 109 611	<b>331166</b>	
Fortsetzung nächste Seite / continued on next page / suite page suivante / continuación página próxima / Продолжение на следующей странице								

V

					Reference	Item No.	
[50]	Ø 5 mm					<b>MK-5H</b>	
<b>293</b>	<b>81</b>						
<b>BVD</b>		D (LA)	4	1968 cm <sup>3</sup> 4V	90 kW (122 PS)	95,50 mm	
[8]	H 35 x 26 x 26				038 109 309 A 038 109 309 B 038 109 309 C	<b>50 006 418</b>	
<b>294</b>	<b>82</b>						
<b>ABV</b>	01.1994 → 04.1999	B (NA)	6	2861 cm <sup>3</sup> 2V	135-140 kW (184-190 PS)	10 90,30 mm	
IN [2]	39,0 x 7 x 106,0	S - -		- 45° - VS -	22 - III	021 109 601 H 021 109 601 J 021 109 601 K	<b>39372</b>
EX [2]	34,0 x 7 x 107,0	RA/S- -		- 45° - VS -	22 - III	021 109 611 D	<b>39300</b>
[50]	Ø 7 mm					021 109 651	<b>MK-7H</b>
IN/EX [4]	12,08/15 x 7 x 38,0	B1				027 103 419	<b>81-33100</b>
[8]	H 35 x 26 x 26					034 109 309 034 109 309 AC 034 109 309 AD 034 109 309 N 074 109 309	<b>50 006 460</b>
<b>295</b>	<b>82,5</b>						
<b>AXA</b>	11.2003 → 08.2015	BG (NA)	4	1984 cm <sup>3</sup> 2V	85 kW (115 PS)	10,3 92,80 mm	
<b>BEH</b>	02.2002 → 06.2006	BG (NA)	4	1984 cm <sup>3</sup> 2V	85 kW (116 PS)	10,4 92,80 mm	
<b>BSX</b>	02.2006 →	BG (NA)	4	1984 cm <sup>3</sup> 2V	80 kW (109 PS)	10,3:1 92,80 mm	
IN [2]	39,5 x 7 x 91,9	S - -		- 45° - -	22 - III	06A 109 601E 078 109 601A 078 109 601B 078 109 601E 078 109 601F	<b>33403</b>
EX [2]	33,0 x 7 x 91,2	A/S - -		- 45° - VS -	22 - III	048 109 611B 078 109 611C	<b>33416</b>
[50]	Ø 7 mm					021 109 651	<b>MK-7H</b>
IN/EX [4]	12,08/15 x 7 x 36,5	B1				037 103 415 037 103 419 B	<b>81-33103</b>
IN/EX [4]	12,25/15 x 7 x 36,5	B1					<b>81-33104</b>
[8]	H 35 x 26 x 26					050 109 309 050 109 309 A 050 109 309 H 050 109 309 J	<b>50 006 417</b>
<b>296</b>	<b>82,5</b>						
<b>9A</b>	08.1988 → 12.1995	B (NA)	4	1984 cm <sup>3</sup> 4V	100 kW (136 PS)	10,8 92,80 mm	
IN [2]	32,0 x 7 x 95,5	S - -		- 45° - VS -	9 - III	027 109 601 C	<b>33125</b>
EX [2]	28,0 x 7 x 98,2	A/S - Cr -		- 45° - VS -	9 - III	027 109 611 A 027 109 611 B 027 109 611 C 027 109 611 D	<b>33050</b>
[50]	Ø 7 mm					027 109 651	<b>RK-7H</b>
Fortsetzung nächste Seite / continued on next page / suite page suivante / continuación página próxima / Продолжение на следующей странице							

					Reference	Item No.
	IN/EX [4]	12,08/15 x 7 x 38,0	B1		027 103 419	<b>81-33100</b>
	[8]	H 35 x 26 x 26			034 109 309 034 109 309 AC 034 109 309 AD 034 109 309 N 074 109 309	<b>50 006 460</b>

## 297 82,5

<b>2E</b>	09.1989 → 12.1995	B (NA)	4	1984 cm <sup>3</sup>	2V	85 kW	(115 PS)	10,5	92,80 mm
<b>ACX</b>	08.1991 → 09.1983	B (NA)	4	1984 cm <sup>3</sup>	2V	78 kW	(106 PS)	10,4:1	92,80 mm
<b>ADY</b>	08.1993 → 05.2000	B (NA)	4	1984 cm <sup>3</sup>	2V	85 kW	(115 PS)	10,4	92,80 mm

	IN [2]	39,5 x 7 x 91,9	S - -	- 45° - -	22 - III	06A 109 601E 078 109 601A 078 109 601B 078 109 601E 078 109 601F	<b>33403</b>
	IN [2] EX [2]	39,5 x 8 x 91,9 33,0 x 7 x 91,2	S - Cr - A/S - -	- 45° - VS - - 45° - VS -	22 - III 22 - III	048 109 601 A 048 109 611B 078 109 611C	<b>33313</b> <b>33416</b>
	EX [2]	33,0 x 8 x 91,2	A/S - -	- 45° - VS -	22 - III	048 109 611 A 053 109 611	<b>33048</b>
	[50] [50]	∅ 7 mm ∅ 8 mm				021 109 651 113 109 651 A 400 501 068	<b>MK-7H</b> <b>MK-8H</b>
	IN/EX [4] IN/EX [4]	12,06/15 x 8 x 36,5 12,08/15 x 7 x 36,5	B1 B1			056 103 419 A 037 103 415 037 103 419 B	<b>81-3310</b> <b>81-33103</b>
	IN/EX [4] IN/EX [4] IN/EX [4]	12,13/15 x 8 x 36,5 12,20/15 x 8 x 36,5 12,25/15 x 7 x 36,5	B1 B1 B1				<b>81-3312</b> <b>81-3311</b> <b>81-33104</b>
	[8]	H 35 x 26 x 26				050 109 309 050 109 309 A 050 109 309 H 050 109 309 J 034 109 309 034 109 309 AC 034 109 309 AD 034 109 309 N 074 109 309	<b>50 006 417</b>        <b>50 006 460</b>
	[8]	H 35 x 26 x 26					

## 298 82,5

<b>ABF</b>	08.1991 →	B (NA)	4	1984 cm <sup>3</sup>	4V	110 kW	(150 PS)	10,4	92,80 mm
------------	-----------	--------	---	----------------------	----	--------	----------	------	----------

	IN [2]	32,0 x 7 x 95,5	S - -	- 45° - VS -	22 - III	051 109 601 B	<b>33308</b>		
	[50]	∅ 7 mm				021 109 651	<b>MK-7H</b>		
	IN/EX [4] IN/EX [4]	12,05/15 x 7 x 35,0 12,08/15 x 7 x 36,5	B1 B1			051 103 419 037 103 415 037 103 419 B	<b>81-33101</b> <b>81-33103</b>		
	IN/EX [4]	12,25/15 x 7 x 36,5	B1				<b>81-33104</b>		
	AS					051 109 022 051 109 022 B	<b>50 006 306</b> (1)		
	(1) Schalenhartguss/chilled cast iron/pièce moulée trempée en surface/fundición en coquilla/Отливка с отбелсным поверхностным слоем								

Fortsetzung nächste Seite / continued on next page / suite page suivante / continuación página próxima / Продолжение на следующей странице

					Reference	Item No.
[8]	H 35 x 26 x 26				034 109 309 034 109 309 AC 034 109 309 AD 034 109 309 N 074 109 309	<b>50 006 460</b>

## 299

82,5

ADC	11.1991 → 12.2003	B (NA)	4	1984 cm <sup>3</sup> 2V	81-85 kW (110-116 PS)	10,4:1	92,80 mm
IN [2]	39,5 x 7 x 91,9	S - -	- 45° - -	22 - III	06A 109 601E 078 109 601A 078 109 601B 078 109 601E 078 109 601F		<b>33403</b>
IN [2] EX [2]	39,5 x 8 x 91,9 33,0 x 7 x 91,2	S - Cr - A/S - -	- 45° - VS - - 45° - VS -	22 - III 22 - III	048 109 601 A 048 109 611B 078 109 611C		<b>33313</b> <b>33416</b>
EX [2]	33,0 x 8 x 91,2	A/S - -	- 45° - VS -	22 - III	048 109 611 A 053 109 611		<b>33048</b>
[50] [50]	∅ 7 mm ∅ 8 mm				021 109 651 113 109 651 A 400 501 068		<b>MK-7H</b> <b>MK-8H</b>
IN/EX [4] IN/EX [4]	12,06/15 x 8 x 36,5 12,08/15 x 7 x 36,5	B1 B1			056 103 419 A 037 103 415 037 103 419 B		<b>81-3310</b> <b>81-33103</b>
IN/EX [4] IN/EX [4] IN/EX [4]	12,13/15 x 8 x 36,5 12,20/15 x 8 x 36,5 12,25/15 x 7 x 36,5	B1 B1 B1					<b>81-3312</b> <b>81-3311</b> <b>81-33104</b>
[8]	H 35 x 26 x 26				050 109 309 050 109 309 A 050 109 309 H 050 109 309 J		<b>50 006 417</b>

## 300

82,5

AEP	03.1995 → 12.1997	B (NA)	4	1984 cm <sup>3</sup> 2V	79 kW (107 PS)	10,4	92,80 mm
IN [2]	39,5 x 7 x 91,9	S - -	- 45° - -	22 - III	06A 109 601E 078 109 601A 078 109 601B 078 109 601E 078 109 601F		<b>33403</b>
IN [2] EX [2]	39,5 x 8 x 91,9 33,0 x 7 x 91,2	S - Cr - A/S - -	- 45° - VS - - 45° - VS -	22 - III 22 - III	048 109 601 A 048 109 611B 078 109 611C		<b>33313</b> <b>33416</b>
[50] [50]	∅ 7 mm ∅ 8 mm				021 109 651 113 109 651 A 400 501 068		<b>MK-7H</b> <b>MK-8H</b>
IN/EX [4] IN/EX [4]	12,06/15 x 8 x 36,5 12,08/15 x 7 x 36,5	B1 B1			056 103 419 A 037 103 415 037 103 419 B		<b>81-3310</b> <b>81-33103</b>
IN/EX [4] IN/EX [4] IN/EX [4]	12,13/15 x 8 x 36,5 12,20/15 x 8 x 36,5 12,25/15 x 7 x 36,5	B1 B1 B1					<b>81-3312</b> <b>81-3311</b> <b>81-33104</b>
					050 109 101A		<b>50 006 398</b> (1)
(1) Schalenhartguss/chilled cast iron/pièce moulée trempée en surface/fundición en coquilla/Отливка с отбелсным поверхностным слоем							

Fortsetzung nächste Seite / continued on next page / suite page suivante / continuación página próxima / Продолжение на следующей странице



					Reference	Item No.
[8]	H 35 x 26 x 26				050 109 309 050 109 309 A 050 109 309 H 050 109 309 J	50 006 417
[8]	H 35 x 26 x 26				034 109 309 034 109 309 AC 034 109 309 AD 034 109 309 N 074 109 309	50 006 460

## 301

**82,5**

AGG	07.1995 → 06.2002	B (NA)	4	1984 cm <sup>3</sup>	2V	85 kW	(115 PS)	10	92,80 mm
IN [2]	39,5 x 7 x 91,9	S - -	-	45°	-	22 - III	06A 109 601E 078 109 601A 078 109 601B 078 109 601E 078 109 601F		33403
EX [2]	33,0 x 7 x 91,2	A/S - -	-	45°	VS -	22 - III	048 109 611B 078 109 611C		33416
[50]	Ø 7 mm						021 109 651		MK-7H
IN/EX [4]	12,06/15 x 8 x 36,5	B1					056 103 419 A 037 103 415 037 103 419 B		81-3310 81-33103
IN/EX [4]	12,13/15 x 8 x 36,5	B1							81-3312
IN/EX [4]	12,20/15 x 8 x 36,5	B1							81-3311
IN/EX [4]	12,25/15 x 7 x 36,5	B1							81-33104
							050 109 101A		50 006 398 (1)
	(1) Schalenhartguss/chilled cast iron/pièce moulée trempée en surface/fundición en coquilla/Отливка с отбеленным поверхностным слоем								
[8]	H 35 x 26 x 26						050 109 309 050 109 309 A 050 109 309 H 050 109 309 J		50 006 417

## 302

**82,5**

ACK	08.1996 → 12.1998	B (NA)	6	2771 cm <sup>3</sup>	5V	142 kW	(193 PS)	10,6	86,40 mm
AGE	05.1997 → 09.1999	B (NA)	6	2771 cm <sup>3</sup>	5V	132 kW	(180 PS)	10,6	86,40 mm
ALG	06.1997 → 11.2000	B (NA)	6	2771 cm <sup>3</sup>	5V	142 kW	(193 PS)	10,6	86,40 mm
ALT	11.2001 → 05.2005	B (NA)	4	1984 cm <sup>3</sup>	5V	96 kW	(130 PS)	10,3	92,80 mm
AMX	11.2000 → 05.2005	B (NA)	6	2771 cm <sup>3</sup>	5V	142 kW	(193 PS)	10,6	86,40 mm
APR	01.1999 → 11.2000	B (NA)	6	2771 cm <sup>3</sup>	5V	142 kW	(193 PS)	10,6	86,40 mm
AQD	08.1996 → 11.2000	B (NA)	6	2771 cm <sup>3</sup>	5V	142 kW	(193 PS)	10,6	86,40 mm
ATQ	06.1997 → 08.2005	B (NA)	6	2771 cm <sup>3</sup>	5V	142 kW	(193 PS)	10,6	86,40 mm
ATX	09.1999 → 11.2000	B (NA)	6	2771 cm <sup>3</sup>	5V	140 kW	(190 PS)	10,6	86,40 mm
BBG	09.1999 → 11.2010	B (NA)	6	2771 cm <sup>3</sup>	5V	140 kW	(190 PS)	10,6	86,40 mm

99 942 6..

IN [2]	27,0 x 6 x 105,1	S - -	-	45°	VS -	22 - III	058 109 601 C 058 109 601 P		33413
EX [2]	30,1 x 6 x 103,9	RA/S- Cr -	-	45°	VS -	22 - III	058 109 611 M 06B 109 611 D		331107
[50]	Ø 6 mm						036 109 651A		MK-6H
IN/EX [4]	11,04 x 6 x 39,0	B1							81-33121 <b>NEW</b>
IN/EX [4]	11,05 x 6 x 36,0	B1					058 103 415		81-33111
IN/EX [4]	11,15 x 6 x 36,0	B1							81-33118 <b>NEW</b>
EX [4]	11,04 x 6 x 39,0	G2							81-33122 <b>NEW</b>

Fortsetzung nächste Seite / continued on next page / suite page suivante / continuación página próxima / Продолжение на следующей странице

					Reference	Item No.
[8]	H 24 x 24 x 24				058 109 309 B 058 109 309 F 058 109 309 J	<b>50 006 425</b> (1)
[8]	H 33,5 x 25,6 x 25,6				058 109 309 A 058 109 309 E 058 109 309 K	<b>50 006 426</b> (2)
	(1) Einlass/intake/admission/entrada/коллектора					
	(2) Auslass/Exhaust/sortie/salida/Выпуск					

## 303

82,5

AKR	05.1997 → 06.2002	B	(NA)	4	1984 cm <sup>3</sup>	2V	85 kW	(115 PS)	10,3	92,80 mm		
IN [2]	39,5 x 7 x 91,9	S	-	-	-	45°	-	22	-	III	06A 109 601E 078 109 601A 078 109 601B 078 109 601E 078 109 601F	<b>33403</b>
EX [2]	33,0 x 7 x 91,2	A/S	-	-	-	45°	VS	22	-	III	048 109 611B 078 109 611C	<b>33416</b>
[50]	∅ 7 mm										021 109 651	<b>MK-7H</b>
IN/EX [4]	12,06/15 x 8 x 36,5	B1									056 103 419 A	<b>81-3310</b>
IN/EX [4]	12,13/15 x 8 x 36,5	B1										<b>81-3312</b>
IN/EX [4]	12,20/15 x 8 x 36,5	B1										<b>81-3311</b>
											050 109 101A	<b>50 006 398</b> (1)
	(1) Schalenhartguss/chilled cast iron/pièce moulée trempée en surface/fundición en coquilla/Отливка с отбеленным поверхностным слоем											
[8]	H 35 x 26 x 26										050 109 309 050 109 309 A 050 109 309 H 050 109 309 J	<b>50 006 417</b>

## 304

82,5

AEG	01.1998 → 12.2013	B	(NA)	4	1984 cm <sup>3</sup>	2V	85 kW	(115 PS)	10,5	92,80 mm		
ATU	06.1998 → 06.2002	B	(NA)	4	1984 cm <sup>3</sup>	2V	85 kW	(116 PS)	10,4:1	92,80 mm		
AWF	06.1998 → 06.2002	B	(NA)	4	1984 cm <sup>3</sup>	2V	85 kW	(115 PS)	10,4:1	92,80 mm		
AWG	06.1998 → 06.2002	B	(NA)	4	1984 cm <sup>3</sup>	2V	85 kW	(116 PS)	10,4:1	92,80 mm		
IN [2]	39,5 x 7 x 91,9	S	-	-	-	45°	-	22	-	III	06A 109 601E 078 109 601A 078 109 601B 078 109 601E 078 109 601F	<b>33403</b>
EX [2]	33,0 x 7 x 91,2	A/S	-	-	-	45°	VS	22	-	III	048 109 611B 078 109 611C	<b>33416</b>
[50]	∅ 7 mm										021 109 651	<b>MK-7H</b>
IN/EX [4]	12,08/15 x 7 x 36,5	B1									037 103 415 037 103 419 B	<b>81-33103</b>
IN/EX [4]	12,25/15 x 7 x 36,5	B1										<b>81-33104</b>
											050 109 101A	<b>50 006 398</b> (1)
	(1) Schalenhartguss/chilled cast iron/pièce moulée trempée en surface/fundición en coquilla/Отливка с отбеленным поверхностным слоем											
Fortsetzung nächste Seite / continued on next page / suite page suivante / continuación página próxima / Продолжение на следующей странице												

					Reference	Item No.
[8]	H 35 x 26 x 26				050 109 309 050 109 309 A 050 109 309 H 050 109 309 J	<b>50 006 417</b>

## 305 82,5

APK	08.1998 → 09.2010	B (NA)	4	1984 cm <sup>3</sup>	2V	85 kW	(116 PS)	10,5	92,80 mm
AQY	01.1998 → 09.2010	B (NA)	4	1984 cm <sup>3</sup>	2V	85 kW	(115 PS)	10,4	92,80 mm
ATM	04.2000 → 03.2010	B (NA)	4	1984 cm <sup>3</sup>	2V	85 kW	(115 PS)	10,5	92,80 mm
AZG	01.1998 → 12.2013	B (NA)	4	1984 cm <sup>3</sup>	2V	85 kW	(115 PS)	10,5	92,80 mm
AZH	04.2000 → 06.2006	B (NA)	4	1984 cm <sup>3</sup>	2V	85 kW	(115 PS)	10,5	92,80 mm
AZJ	01.1998 → 12.2013	B (NA)	4	1984 cm <sup>3</sup>	2V	85 kW	(115 PS)	10,3	92,80 mm
AZM	11.2000 → 05.2005	B (NA)	4	1984 cm <sup>3</sup>	2V	85 kW	(116 PS)	10,5	92,80 mm
BDC	09.2002 → 10.2010	B (NA)	4	1984 cm <sup>3</sup>	2V	85 kW	(115 PS)	10,3	92,80 mm
BEJ	04.2001 → 01.2005	B (NA)	4	1984 cm <sup>3</sup>	2V	85 kW	(115 PS)	10,3	92,80 mm
BER	01.1998 → 12.2013	B (NA)	4	1984 cm <sup>3</sup>	2V	85 kW	(116 PS)	10,3	92,80 mm
BEV	01.1998 → 12.2013	B (NA)	4	1984 cm <sup>3</sup>	2V	85-86 kW	(116-117 PS)	10,3	92,80 mm
BGD	09.2002 → 10.2010	B (NA)	4	1984 cm <sup>3</sup>	2V	85 kW	(115 PS)	10,3	92,80 mm
BHP	10.1998 → 12.2013	B (NA)	4	1984 cm <sup>3</sup>	2V	85 kW	(115 PS)	10,3:1	92,80 mm

IN [2]	39,5 x 7 x 91,9	S - -	-	45°	-	22 - III	06A 109 601E 078 109 601A 078 109 601B 078 109 601E 078 109 601F	<b>33403</b>
EX [2]	33,0 x 7 x 91,2	A/S - -	-	45°	VS -	22 - III	048 109 611B 078 109 611C	<b>33416</b>
[50]	Ø 7 mm						021 109 651	<b>MK-7H</b>
IN/EX [4]	12,08/15 x 7 x 36,5	B1					037 103 415 037 103 419 B	<b>81-33103</b>
IN/EX [4]	12,25/15 x 7 x 36,5	B1						<b>81-33104</b>
[8]	H 35 x 26 x 26						050 109 309 050 109 309 A 050 109 309 H 050 109 309 J	<b>50 006 417</b>

## 306 82,5

AVH	07.1998 → 12.2013	B (NA)	4	1984 cm <sup>3</sup>	2V	85-86 kW	(115-117 PS)	10,4:1	92,80 mm
BBX	04.2002 →	B (NA)	4	1984 cm <sup>3</sup>	2V	85-88 kW	(115-120 PS)	10,5	92,80 mm
BHY	01.2005 →	B (NA)	4	1984 cm <sup>3</sup>	2V	85 kW	(116 PS)	10,5	92,80 mm
CBPA	10.1998 →	B (NA)	4	1984 cm <sup>3</sup>	2V	85-86 kW	(116-117 PS)		92,80 mm

IN [2]	39,5 x 7 x 91,9	S - -	-	45°	-	22 - III	06A 109 601E 078 109 601A 078 109 601B 078 109 601E 078 109 601F	<b>33403</b>
EX [2]	33,0 x 7 x 91,2	A/S - -	-	45°	VS -	22 - III	048 109 611B 078 109 611C	<b>33416</b>
[50]	Ø 7 mm						021 109 651	<b>MK-7H</b>
IN/EX [4]	12,08/15 x 7 x 36,5	B1					037 103 415 037 103 419 B	<b>81-33103</b>
IN/EX [4]	12,25/15 x 7 x 36,5	B1						<b>81-33104</b>

## 307 82,5

AXW	10.2003 → 11.2008	B (NA)	4	1984 cm <sup>3</sup>	4V	110 kW	(150 PS)	11,5	92,80 mm
-----	-------------------	--------	---	----------------------	----	--------	----------	------	----------

Fortsetzung nächste Seite / continued on next page / suite page suivante / continuación página próxima / Продолжение на следующей странице

V

					Reference	Item No.
IN [2]	33,9 x 6 x 104,0	S - -	- 45° - -	22 - III	06D 109 601K 06E 109 601E 06E 109 601F	<b>331116</b>
EX [2]	28,0 x 6 x 101,9	I/S - Cr -	- 45° - -	22 - III	06D 109 611K 06D 109 611L 06D 109 611T 06E 109 611D 06K 109 611	<b>331117</b> (1)
EX [2] (1) OES specification (2) IAM specification	28,0 x 6 x 102,0	RA/S- Cr -	- 45° - VS -	22 - III		<b>331144</b> (2)
[50]	∅ 6 mm				036 109 651A	<b>MK-6H</b>
IN/EX [4] IN/EX [4] IN/EX [4] EX [4]	11,04 x 6 x 39,0 11,05 x 6 x 36,0 11,15 x 6 x 36,0 11,04 x 6 x 39,0	B1 B1 B1 G2			058 103 415	<b>81-33121</b> <small>NEW</small> <b>81-33111</b> <b>81-33118</b> <small>NEW</small> <b>81-33122</b> <small>NEW</small>
[8]	H 12 x 34,5				022 109 423 A 022 109 423 D	<b>50 006 419</b>
[8]					06E 109 417 F	<b>50 006 149</b>

## 308 82,5

<b>BLR</b>	10.2003 → 11.2010	B (NA)	4	1984 cm <sup>3</sup>	4V	110 kW	(150 PS)	11,5	92,80 mm
<b>BLX</b>	10.2003 → 11.2010	B (NA)	4	1984 cm <sup>3</sup>	4V	110 kW	(150 PS)	11,5	92,80 mm
<b>BLY</b>	10.2003 → 11.2010	B (NA)	4	1984 cm <sup>3</sup>	4V	110 kW	(150 PS)	11,5	92,80 mm
<b>BVX</b>	01.2004 → 11.2010	B (NA)	4	1984 cm <sup>3</sup>	4V	110 kW	(150 PS)	11,5	92,80 mm
<b>BVY</b>	10.2003 → 11.2010	B (NA)	4	1984 cm <sup>3</sup>	4V	110 kW	(150 PS)	11,5	92,80 mm
<b>BVZ</b>	10.2003 → 11.2010	B (NA)	4	1984 cm <sup>3</sup>	4V	110 kW	(150 PS)	11,5	92,80 mm

IN [2]	33,9 x 6 x 104,0	S - -	- 45° - -	22 - III	06D 109 601K 06E 109 601E 06E 109 601F	<b>331116</b>
EX [2]	28,0 x 6 x 101,9	I/S - Cr -	- 45° - -	22 - III	06D 109 611K 06D 109 611L 06D 109 611T 06E 109 611D 06K 109 611	<b>331117</b> (1)
EX [2] (1) OES specification (2) IAM specification	28,0 x 6 x 102,0	RA/S- Cr -	- 45° - VS -	22 - III		<b>331144</b> (2)
[50]	∅ 6 mm				036 109 651A	<b>MK-6H</b>
IN/EX [4] IN/EX [4] IN/EX [4] EX [4]	11,04 x 6 x 39,0 11,05 x 6 x 36,0 11,15 x 6 x 36,0 11,04 x 6 x 39,0	B1 B1 B1 G2			058 103 415	<b>81-33121</b> <small>NEW</small> <b>81-33111</b> <b>81-33118</b> <small>NEW</small> <b>81-33122</b> <small>NEW</small>
(3)	ES AS (ST)				06D 109 101 AL 06D 109 101 AP 06D 109 102 AK	<b>50 007 588</b> (3) <b>50 007 589</b> (3)
[8]	H 12 x 34,5				022 109 423 A 022 109 423 D	<b>50 006 419</b>
[8]					06E 109 417 F	<b>50 006 149</b>

					Reference	Item No.		
<b>309</b>	<b>82,5</b>							
<b>AXX</b>	10.2004 → 11.2010	B (LA)	4	1984 cm <sup>3</sup>	4V	147 kW (200 PS)	10,3	92,80 mm
<b>BPY</b>	10.2004 → 08.2015	B (LA)	4	1984 cm <sup>3</sup>	4V	147 kW (200 PS)	10,3	92,80 mm
<b>BWA</b>	10.2004 →	B (LA)	4	1984 cm <sup>3</sup>	4V	147 kW (200 PS)	10,3	92,80 mm
	IN [2]	33,9 x 6 x 104,0	S - -	- 45° - VS -	22 - III	06D 109 601M 06J 106 601H 079 109 601B 079 109 601E		<b>331125</b>
	EX [2]	28,0 x 6 x 101,9	RA/S- Cr - Na	- 45° - VS -	22 - III	06D 109 611 P 06D 109 611H 06J 109 611D		<b>331126</b>
	[50]	∅ 6 mm				036 109 651A		<b>MK-6H</b>
	IN/EX [4]	11,04 x 6 x 39,0	B1			058 103 415		<b>81-33121</b>
	IN/EX [4]	11,05 x 6 x 36,0	B1					<b>81-33111</b>
	IN/EX [4]	11,15 x 6 x 36,0	B1					<b>81-33118</b>
	EX [4]	11,04 x 6 x 39,0	G2					<b>81-33122</b>
		ES				06F 109 101 B		<b>50 007 586</b> (1)
		AS				06F 109 101J		<b>50 007 587</b> (1)
	(1) (ST)					06F 109 102 B		
	[8]	H 12 x 34,5				022 109 423 A 022 109 423 D		<b>50 006 419</b>
	[8]					06E 109 417 F		<b>50 006 149</b>
<b>310</b>	<b>82,5</b>							
<b>CAWA</b>	09.2007 → 07.2018	B (LA)	4	1984 cm <sup>3</sup>	4V	125 kW (170 PS)	10,5:1	92,80 mm
<b>CAWB</b>	10.2004 →	B (LA)	4	1984 cm <sup>3</sup>	4V	147 kW (200 PS)	10,5	92,80 mm
<b>CBFA</b>	10.2004 →	B (LA)	4	1984 cm <sup>3</sup>	4V	147-157 kW (200-213 PS)	10,5	92,80 mm
<b>CCTA</b>	10.2004 →	B (LA)	4	1984 cm <sup>3</sup>	4V	147-157 kW (200-213 PS)	10,5	92,80 mm
<b>CCTB</b>	08.2007 → 07.2018	B (LA)	4	1984 cm <sup>3</sup>	4V	125 kW (170 PS)		92,80 mm
40 247 6.., 41 198 6..								
	IN [2]	33,9 x 6 x 104,0	S - -	- 45° - VS -	22 - III	06D 109 601M 06J 106 601H 079 109 601B 079 109 601E		<b>331125</b>
	EX [2]	28,0 x 6 x 101,9	RA/S- Cr - Na	- 45° - VS -	22 - III	06D 109 611 P 06D 109 611H 06J 109 611D		<b>331126</b>
	[50]	∅ 6 mm				036 109 651A		<b>MK-6H</b>
	IN/EX [4]	11,04 x 6 x 39,0	B1			058 103 415		<b>81-33121</b>
	IN/EX [4]	11,05 x 6 x 36,0	B1					<b>81-33111</b>
	IN/EX [4]	11,15 x 6 x 36,0	B1					<b>81-33118</b>
	EX [4]	11,04 x 6 x 39,0	G2					<b>81-33122</b>
		ES				06H109021K		<b>50 007 673</b>
	[4]					06E 109 417 06E 109 417 E		<b>50 006 148</b>
<b>311</b>	<b>82,5</b>							
<b>BGP</b>	01.2005 → 10.2010	B (NA)	5	2480 cm <sup>3</sup>	4V	110-112 kW (150-152 PS)	10	92,80 mm
<b>BPR</b>	07.2005 → 09.2010	B (NA)	5	2480 cm <sup>3</sup>	4V	110 kW (150 PS)	9,5:1	92,80 mm
<b>BPS</b>	07.2005 → 09.2010	B (NA)	5	2480 cm <sup>3</sup>	4V	110 kW (150 PS)	9,5:1	92,80 mm

Fortsetzung nächste Seite / continued on next page / suite page suivante / continuación página próxima / Продолжение на следующей странице

					Reference	Item No.
IN [2] EX [2]	32,4 x 6 x 104,1 28,0 x 6 x 101,9	S - - I/S - Cr -	- 45° - - - 45° - -	22 - III 22 - III	06E 109 601Q 06D 109 611K 06D 109 611L 06D 109 611T 06E 109 611D 06K 109 611	<b>331138</b> <b>331117</b> (1)
EX [2] (1) OES specification (2) IAM specification	28,0 x 6 x 102,0	RA/S- Cr -	- 45° - VS -	22 - III		<b>331144</b> (2)
[50]	∅ 6 mm				036 109 651A	<b>MK-6H</b>
IN/EX [4] IN/EX [4] IN/EX [4] EX [4]	11,04 x 6 x 39,0 11,05 x 6 x 36,0 11,15 x 6 x 36,0 11,04 x 6 x 39,0	B1 B1 B1 G2			058 103 415	<b>81-33121</b> <small>NEW</small> <b>81-33111</b> <b>81-33118</b> <small>NEW</small> <b>81-33122</b> <small>NEW</small>
[8]	H 12 x 34,5				022 109 423 A 022 109 423 D	<b>50 006 419</b>
[8]					06E 109 417 F	<b>50 006 149</b>

## 312 82,5

<b>BGQ</b>	01.2005 → 10.2010	B (NA)	5	2480 cm <sup>3</sup>	4V	110-112 kW	(150-152 PS)	10	92,80 mm
<b>BTK</b>	06.2005 → 10.2010	B (NA)	5	2480 cm <sup>3</sup>	4V	110-112 kW	(150-152 PS)	9,5:1	92,80 mm
<b>CBTA</b>	05.2007 →	B (NA)	5	2480 cm <sup>3</sup>	4V	112-127 kW	(152-173 PS)		92,80 mm
<b>CBUA</b>	05.2007 →	B (NA)	5	2480 cm <sup>3</sup>	4V	112-127 kW	(152-173 PS)	9,5	92,80 mm
<b>CCCA</b>	07.2007 →	B (NA)	5	2480 cm <sup>3</sup>	4V	125 kW	(170 PS)		92,80 mm

IN [2] EX [2]	32,4 x 6 x 104,1 28,0 x 6 x 101,9	S - - I/S - Cr -	- 45° - - - 45° - -	22 - III 22 - III	06E 109 601Q 06D 109 611K 06D 109 611L 06D 109 611T 06E 109 611D 06K 109 611	<b>331138</b> <b>331117</b> (1)
EX [2] (1) OES specification (2) IAM specification	28,0 x 6 x 102,0	RA/S- Cr -	- 45° - VS -	22 - III		<b>331144</b> (2)
[50]	∅ 6 mm				036 109 651A	<b>MK-6H</b>
IN/EX [4] IN/EX [4] IN/EX [4] EX [4]	11,04 x 6 x 39,0 11,05 x 6 x 36,0 11,15 x 6 x 36,0 11,04 x 6 x 39,0	B1 B1 B1 G2			058 103 415	<b>81-33121</b> <small>NEW</small> <b>81-33111</b> <b>81-33118</b> <small>NEW</small> <b>81-33122</b> <small>NEW</small>
[8]					06E 109 417 F	<b>50 006 149</b>

## 313 82,5

<b>CCZA</b>	07.2005 →	B (LA)	4	1984 cm <sup>3</sup>	4V	147 kW	(200 PS)	9,6	92,80 mm
<b>CCZB</b>	02.2009 → 07.2018	B (A)	4	1984 cm <sup>3</sup>	4V	155 kW	(211 PS)		92,80 mm

40 247 6.., 41 198 6..

IN [2]	33,9 x 6 x 104,0	S - -	- 45° - VS -	22 - III	06D 109 601M 06J 106 601H 079 109 601B 079 109 601E	<b>331125</b>
EX [2]	28,0 x 6 x 101,9	RA/S- Cr - Na	- 45° - VS -	22 - III	06D 109 611 P 06D 109 611H 06J 109 611D	<b>331126</b>

Fortsetzung nächste Seite / continued on next page / suite page suivante / continuación página próxima / Продолжение на следующей странице



					Reference	Item No.
[50]	Ø 6 mm				036 109 651A	<b>MK-6H</b>
IN/EX [4] IN/EX [4] IN/EX [4] EX [4]	11,04 x 6 x 39,0 11,05 x 6 x 36,0 11,15 x 6 x 36,0 11,04 x 6 x 39,0	B1 B1 B1 G2			058 103 415	<b>81-33121</b> <b>81-33111</b> <b>81-33118</b> <b>81-33122</b>
	ES AS				06H109021K 06H 109 022 AH 06H 109 022 BC	<b>50 007 673</b> <b>50 007 712</b>
[4]					06E 109 417 06E 109 417 E	<b>50 006 148</b>

## 314 82,5

<b>BYD Euro 4</b>	09.2006 → 12.2008	B (LA)	4	1984 cm <sup>3</sup>	4V	169 kW	(230 PS)	9,8	92,80 mm
<b>CDLC</b>	11.2009 → 11.2017	B (LA)	4	1984 cm <sup>3</sup>	4V	188 kW	(256 PS)		92,80 mm
<b>CDLF</b>	11.2009 → 11.2012	B (LA)	4	1984 cm <sup>3</sup>	4V	199 kW	(270 PS)	9,8	92,80 mm

IN [2]	33,9 x 6 x 104,0	S - -	- 45° - VS -	22 - III	06D 109 601M 06J 106 601H 079 109 601B 079 109 601E	<b>331125</b>
EX [2]	28,0 x 6 x 101,9	RA/S- Cr - Na	- 45° - VS -	22 - III	06D 109 611 P 06D 109 611H 06J 109 611D	<b>331126</b>
[50]	Ø 6 mm				036 109 651A	<b>MK-6H</b>
IN/EX [4] IN/EX [4] IN/EX [4] EX [4]	11,04 x 6 x 39,0 11,05 x 6 x 36,0 11,15 x 6 x 36,0 11,04 x 6 x 39,0	B1 B1 B1 G2			058 103 415	<b>81-33121</b> <b>81-33111</b> <b>81-33118</b> <b>81-33122</b>
[8]					06E 109 417 F	<b>50 006 149</b>

## 315 82,5

<b>BZB</b>	05.2007 → 01.2012	B (A)	4	1798 cm <sup>3</sup>	4V	118 kW	(160 PS)	9,6	84,20 mm
40 251 6..									

IN [2]	33,9 x 6 x 104,0	S - -	- 45° - VS -	22 - III	06D 109 601M 06J 106 601H 079 109 601B 079 109 601E	<b>331125</b>
EX [2]	28,0 x 6 x 101,9	RA/S- Cr - Na	- 45° - VS -	22 - III	06D 109 611 P 06D 109 611H 06J 109 611D	<b>331126</b>
[50]	Ø 6 mm				036 109 651A	<b>MK-6H</b>
IN/EX [4] IN/EX [4] IN/EX [4] EX [4]	11,04 x 6 x 39,0 11,05 x 6 x 36,0 11,15 x 6 x 36,0 11,04 x 6 x 39,0	B1 B1 B1 G2			058 103 415	<b>81-33121</b> <b>81-33111</b> <b>81-33118</b> <b>81-33122</b>
	ES AS				06H109021J 06H109022BA	<b>50 007 634</b> <b>50 007 635</b>
[4]					06E 109 417 06E 109 417 E	<b>50 006 148</b>

V

					Reference	Item No.
<b>316</b>	<b>82,5</b>					
<b>CDA4</b> 41 197 6..	05.2007 →	B (LA) 4	1798 cm <sup>3</sup> 4V	118 kW	(160 PS) 9,6	84,10 mm
IN [2]	33,9 x 6 x 104,0	S - -	- 45° - VS -	22 - III	06D 109 601M 06J 106 601H 079 109 601B 079 109 601E	<b>331125</b>
EX [2]	28,0 x 6 x 101,9	I/S - Cr -	- 45° - -	22 - III	06D 109 611K 06D 109 611L 06D 109 611T 06E 109 611D 06K 109 611	<b>331117</b> (1)
EX [2] (1) OES specification (2) IAM specification	28,0 x 6 x 102,0	RA/S- Cr -	- 45° - VS -	22 - III		<b>331144</b> (2)
[50]	∅ 6 mm				036 109 651A	<b>MK-6H</b>
IN/EX [4] IN/EX [4] IN/EX [4] EX [4]	11,04 x 6 x 39,0 11,05 x 6 x 36,0 11,15 x 6 x 36,0 11,04 x 6 x 39,0	B1 B1 B1 G2			058 103 415	<b>81-33121</b> <b>81-33111</b> <b>81-33118</b> <b>81-33122</b>
ES AS					06H109021J 06H109022BA	<b>50 007 634</b> <b>50 007 635</b>
[8]	H 12 x 34,5				022 109 423 A 022 109 423 D	<b>50 006 419</b>
[4]					06E 109 417 06E 109 417 E	<b>50 006 148</b>
<b>317</b>	<b>82,5</b>					
<b>CCZC</b> 40 247 6.., 41 198 6..	09.2007 → 07.2018	B (LA) 4	1984 cm <sup>3</sup> 4V	125 kW	(170 PS) 9,6:1	92,80 mm
IN [2] IN [2]	28,5 x 5 x 110,2 33,9 x 6 x 104,0	S - - S - -	- 45° - - - 45° - VS -	22 - III 22 - III	04E 109 601B 06D 109 601M 06J 106 601H 079 109 601B 079 109 601E	<b>331158</b> <b>331125</b>
EX [2]	25,0 x 5 x 110,1	RA/S- Cr -	- 30° - VS -	22 - III	04E 109 611H 04E 109 611J	<b>331159</b>
EX [2]	28,0 x 6 x 101,9	RA/S- Cr - Na	- 45° - VS -	22 - III	06D 109 611 P 06D 109 611H 06J 109 611D	<b>331126</b>
[50] [50]	∅ 5 mm ∅ 6 mm				036 109 651A	<b>MK-5H</b> <b>MK-6H</b>
IN/EX [4] IN/EX [4] IN/EX [4] EX [4]	11,04 x 6 x 39,0 11,05 x 6 x 36,0 11,15 x 6 x 36,0 11,04 x 6 x 39,0	B1 B1 B1 G2			058 103 415	<b>81-33121</b> <b>81-33111</b> <b>81-33118</b> <b>81-33122</b>
ES					06H109021K	<b>50 007 673</b>
[8]	H 12 x 34,5				022 109 423 A 022 109 423 D	<b>50 006 419</b>
[4]					06E 109 417 06E 109 417 E	<b>50 006 148</b>

V

					Reference	Item No.	
<b>318</b>	<b>82,5</b>						
<b>CGYA</b> 40 251 6..	11.2008 → 11.2010	B	(A)	4	1798 cm <sup>3</sup> 4V	112 kW (152 PS) 9,6 84,10 mm	
	IN [2] 33,9 x 6 x 104,0	S	- -	- 45° - VS -	22 - III	06D 109 601M 06J 106 601H 079 109 601B 079 109 601E	<b>331125</b>
	EX [2] 28,0 x 6 x 101,9	I/S	- Cr -	- 45° - -	22 - III	06D 109 611K 06D 109 611L 06D 109 611T 06E 109 611D 06K 109 611	<b>331117</b> (1)
	EX [2] 28,0 x 6 x 102,0 (1) OES specification (2) IAM specification	RA/S-	Cr -	- 45° - VS -	22 - III		<b>331144</b> (2)
	[50] Ø 6 mm					036 109 651A	<b>MK-6H</b>
	IN/EX [4] 11,04 x 6 x 39,0 IN/EX [4] 11,05 x 6 x 36,0 IN/EX [4] 11,15 x 6 x 36,0 EX [4] 11,04 x 6 x 39,0	B1 B1 B1 G2				058 103 415	<b>81-33121</b> <b>81-33111</b> <b>81-33118</b> <b>81-33122</b>
	ES AS					06H109021J 06H109022BA	<b>50 007 634</b> <b>50 007 635</b>
<b>319</b>	<b>82,5</b>						
<b>CDAB</b> 41 197 6..	11.2008 → 12.2016	B	(LA)	4	1798 cm <sup>3</sup> 4V	112 kW (152 PS) 9,6 84,10 mm	
	IN [2] 33,9 x 6 x 104,0	S	- -	- 45° - VS -	22 - III	06D 109 601M 06J 106 601H 079 109 601B 079 109 601E	<b>331125</b>
	EX [2] 28,0 x 6 x 101,9	I/S	- Cr -	- 45° - -	22 - III	06D 109 611K 06D 109 611L 06D 109 611T 06E 109 611D 06K 109 611	<b>331117</b> (1)
	EX [2] 28,0 x 6 x 102,0 (1) OES specification (2) IAM specification	RA/S-	Cr -	- 45° - VS -	22 - III		<b>331144</b> (2)
	[50] Ø 6 mm					036 109 651A	<b>MK-6H</b>
	IN/EX [4] 11,04 x 6 x 39,0 IN/EX [4] 11,05 x 6 x 36,0 IN/EX [4] 11,15 x 6 x 36,0 EX [4] 11,04 x 6 x 39,0	B1 B1 B1 G2				058 103 415	<b>81-33121</b> <b>81-33111</b> <b>81-33118</b> <b>81-33122</b>
	ES AS					06H109021J 06H109022BA	<b>50 007 634</b> <b>50 007 635</b>
	[4]					06E 109 417 06E 109 417 E	<b>50 006 148</b>
<b>320</b>	<b>82,5</b>						
<b>CDLA</b>	11.2009 → 11.2017	B	(LA)	4	1984 cm <sup>3</sup> 4V	195 kW (265 PS) 9,8 92,80 mm	
<b>CDLJ Euro 6</b>	08.2013 → 05.2014	B	(LA)	4	1984 cm <sup>3</sup> 4V	162 kW (220 PS) 9,8 92,80 mm	
Fortsetzung nächste Seite / continued on next page / suite page suivante / continuación página próxima / Продолжение на следующей странице							

					Reference	Item No.
IN [2]	33,9 x 6 x 104,0	S - -	- 45° - VS -	22 - III	06D 109 601M 06J 106 601H 079 109 601B 079 109 601E	<b>331125</b>
EX [2]	28,0 x 6 x 101,9	RA/S- Cr - Na	- 45° - VS -	22 - III	06D 109 611 P 06D 109 611H 06J 109 611D	<b>331126</b>
[50]	∅ 6 mm				036 109 651A	<b>MK-6H</b>
IN/EX [4]	11,04 x 6 x 39,0	B1			058 103 415	<b>81-33121</b> <small>NEW</small>
IN/EX [4]	11,05 x 6 x 36,0	B1				<b>81-33111</b>
IN/EX [4]	11,15 x 6 x 36,0	B1				<b>81-33118</b> <small>NEW</small>
EX [4]	11,04 x 6 x 39,0	G2				<b>81-33122</b> <small>NEW</small>

## 321 82,5

<b>CCZD</b>	05.2011 → 07.2018	B (LA)	4	1984 cm <sup>3</sup>	4V	132 kW	(180 PS)	9,6:1	92,80 mm
<b>CFPA Euro 4</b>	12.2010 → 10.2016	B (LA)	4	1984 cm <sup>3</sup>	4V	118 kW	(160 PS)	9,6	92,80 mm
<b>CJKA</b>	05.2011 →	B (A)	4	1984 cm <sup>3</sup>	4V	150 kW	(204 PS)	10,5:1	92,80 mm

41 198 6..

IN [2]	33,9 x 6 x 104,0	S - -	- 45° - VS -	22 - III	06D 109 601M 06J 106 601H 079 109 601B 079 109 601E	<b>331125</b>
EX [2]	28,0 x 6 x 101,9	RA/S- Cr - Na	- 45° - VS -	22 - III	06D 109 611 P 06D 109 611H 06J 109 611D	<b>331126</b>
[50]	∅ 6 mm				036 109 651A	<b>MK-6H</b>
IN/EX [4]	11,04 x 6 x 39,0	B1			058 103 415	<b>81-33121</b> <small>NEW</small>
IN/EX [4]	11,05 x 6 x 36,0	B1				<b>81-33111</b>
IN/EX [4]	11,15 x 6 x 36,0	B1				<b>81-33118</b> <small>NEW</small>
EX [4]	11,04 x 6 x 39,0	G2				<b>81-33122</b> <small>NEW</small>
	ES				06H109021K	<b>50 007 673</b>

## 322 82,5

<b>CJKB</b>	07.2012 →	B (A)	4	1984 cm <sup>3</sup>	4V	110 kW	(150 PS)		92,80 mm
-------------	-----------	-------	---	----------------------	----	--------	----------	--	----------

41 198 6..

IN [2]	33,9 x 6 x 104,0	S - -	- 45° - VS -	22 - III	06D 109 601M 06J 106 601H 079 109 601B 079 109 601E	<b>331125</b>
EX [2]	28,0 x 6 x 101,9	RA/S- Cr - Na	- 45° - VS -	22 - III	06D 109 611 P 06D 109 611H 06J 109 611D	<b>331126</b>
[50]	∅ 6 mm				036 109 651A	<b>MK-6H</b>
IN/EX [4]	11,04 x 6 x 39,0	B1			058 103 415	<b>81-33121</b> <small>NEW</small>
IN/EX [4]	11,05 x 6 x 36,0	B1				<b>81-33111</b>
IN/EX [4]	11,15 x 6 x 36,0	B1				<b>81-33118</b> <small>NEW</small>
EX [4]	11,04 x 6 x 39,0	G2				<b>81-33122</b> <small>NEW</small>
	ES				06H103144J 06H103144K 06H109021K	<b>50 007 669</b> (1) <b>50 007 673</b>
	(1) Lagerbock bearing bracket chevalet support pedestal de cojinete кронштейн подшипника					

					Reference	Item No.
<b>323</b>	<b>82,5</b>					
<b>CPLA</b> 41 501 6..	12.2012 → 07.2019	B (LA)	4	1984 cm <sup>3</sup> 4V	155 kW (211 PS)	92,80 mm
IN [2]	33,8 x 6 x 104,0	S - -	- 45° - -	22 - III	06K 109 601 06L 109 601	<b>331162</b>
EX [2]	28,0 x 5,9 x 101,8	RA/S- Cr - Na	- 45° - VS -	22 - III	06E 109 611K 06K 109 611A 06K 109 611E 079 109 611D 079 109 611F 079 109 611G	<b>331160</b>
[50]	Ø 6 mm				036 109 651A	<b>MK-6H</b>
[8]	H 12				04E109423C	<b>50 007 667</b>
[4]					06E109417AA 06E109417N	<b>50 007 657</b>
<b>324</b>	<b>82,5</b>					
<b>CPPA</b> 41 501 6..	12.2012 → 07.2019	B (LA)	4	1984 cm <sup>3</sup> 4V	155 kW (211 PS)	92,80 mm
IN [2]	33,8 x 6 x 104,0	S - -	- 45° - -	22 - III	06K 109 601 06L 109 601	<b>331162</b>
EX [2]	28,0 x 5,9 x 101,8	RA/S- Cr - Na	- 45° - VS -	22 - III	06E 109 611K 06K 109 611A 06K 109 611E 079 109 611D 079 109 611F 079 109 611G	<b>331160</b>
[50]	Ø 6 mm				036 109 651A	<b>MK-6H</b>
[4]					06E109417AA 06E109417N	<b>50 007 657</b>
<b>325</b>	<b>82,5</b>					
<b>CHHA</b>	04.2013 →	B (LA)	4	1984 cm <sup>3</sup> 4V	169 kW (230 PS)	9,6 92,80 mm
<b>CHHB Euro 6</b>	04.2013 →	B (LA)	4	1984 cm <sup>3</sup> 4V	162 kW (220 PS)	9,6 92,80 mm
41 501 6..						
IN [2]	33,8 x 6 x 104,0	S - -	- 45° - -	22 - III	06K 109 601 06L 109 601	<b>331162</b>
EX [2]	28,0 x 5,9 x 101,8	RA/S- Cr - Na	- 45° - VS -	22 - III	06E 109 611K 06K 109 611A 06K 109 611E 079 109 611D 079 109 611F 079 109 611G	<b>331160</b>
EX [2]	28,0 x 6 x 101,9	I/S - Cr -	- 45° - -	22 - III	06D 109 611K 06D 109 611L 06D 109 611T 06E 109 611D 06K 109 611	<b>331117</b> (1)
EX [2]	28,0 x 6 x 102,0 (1) OES specification (2) IAM specification	RA/S- Cr -	- 45° - VS -	22 - III		<b>331144</b> (2)
Fortsetzung nächste Seite / continued on next page / suite page suivante / continuación página próxima / Продолжение на следующей странице						

V

					Reference	Item No.
[50]	Ø 6 mm				036 109 651A	<b>MK-6H</b>
IN/EX [4]	11,04 x 6 x 39,0	B1			058 103 415	<b>81-33121</b> <small>NEW</small>
IN/EX [4]	11,05 x 6 x 36,0	B1		<b>81-33111</b>		
IN/EX [4]	11,15 x 6 x 36,0	B1		<b>81-33118</b> <small>NEW</small>		
EX [4]	11,04 x 6 x 39,0	G2		<b>81-33122</b> <small>NEW</small>		
	(3) Lagerbock bearing bracket chevalet support pedestal de cojinete кронштјин подшпника				06L103144F 06L103144H	<b>50 007 670</b> (3)
[4]					06E109417AA 06E109417N	<b>50 007 657</b>

## 326 82,5

<b>CJXA</b>	05.2015 →	B (A)	4	1984 cm <sup>3</sup>	4V	206 kW	(280 PS)	92,80 mm
<b>CJXE Euro 6</b>	02.2016 → 03.2017	B (LA)	4	1984 cm <sup>3</sup>	4V	195 kW	(265 PS)	92,80 mm
<b>CXCA Euro 6</b>	11.2013 →	B (A)	4	1984 cm <sup>3</sup>	4V	155 kW	(211 PS) 9,6	92,80 mm
<b>CXCB Euro 6</b>	04.2013 →	B (A)	4	1984 cm <sup>3</sup>	4V	162 kW	(220 PS) 9,6	92,80 mm
<b>CXDA Euro 6</b>	04.2013 →	B (LA)	4	1984 cm <sup>3</sup>	4V	162 kW	(220 PS) 9,6	92,80 mm
<b>DKTB Euro 6</b>	03.2017 →	B (LA)	4	1984 cm <sup>3</sup>	4V	180 kW	(245 PS)	92,80 mm
<b>DMFA Euro 6</b>	08.2018 → 11.2020	B (LA)	4	1984 cm <sup>3</sup>	4V	180 kW	(245 PS) 9,6:1	92,80 mm
<b>DNJA</b>	07.2017 →	B (LA)	4	1984 cm <sup>3</sup>	4V	162 kW	(220 PS)	92,80 mm

41 192 6.., 41 501 6.., 41 533 6..

IN [2]	33,8 x 6 x 104,0	S - -	- 45° - -	22 - III	06K 109 601 06L 109 601	<b>331162</b> <small>NEW</small>
EX [2]	28,0 x 5,9 x 101,8	RA/S- Cr - Na	- 45° - VS -	22 - III	06E 109 611K 06K 109 611A 06K 109 611E 079 109 611D 079 109 611F 079 109 611G	<b>331160</b> <small>NEW</small>
[50]	Ø 6 mm				036 109 651A	<b>MK-6H</b>

## 327 82,5

<b>CNTC Euro 6</b>	04.2013 →	B (A)	4	1984 cm <sup>3</sup>	4V	162 kW	(220 PS) 9,6	92,80 mm
--------------------	-----------	-------	---	----------------------	----	--------	--------------	----------

IN [2]	33,8 x 6 x 104,0	S - -	- 45° - -	22 - III	06K 109 601 06L 109 601	<b>331162</b> <small>NEW</small>
EX [2]	28,0 x 6 x 101,9	RA/S- Cr - Na	- 45° - VS -	22 - III	06D 109 611 P 06D 109 611H 06J 109 611D	<b>331126</b>
[50]	Ø 6 mm				036 109 651A	<b>MK-6H</b>
	(1) Lagerbock bearing bracket chevalet support pedestal de cojinete кронштјин подшпника				06L103144F 06L103144H	<b>50 007 670</b> (1)

## 328 82,5

<b>CPKA</b>	06.2013 →	B (A)	4	1798 cm <sup>3</sup>	4V	125 kW	(170 PS)	84,10 mm
<b>CPRA</b>	06.2013 →	B (A)	4	1798 cm <sup>3</sup>	4V	125 kW	(170 PS)	84,10 mm

41 509 6..

Fortsetzung nächste Seite / continued on next page / suite page suivante / continuación página próxima / Продолжение на следующей странице



					Reference	Item No.	
	IN [2] EX [2]  EX [2] (1) OES specification (2) IAM specification	33,8 x 6 x 104,0 28,0 x 6 x 101,9  28,0 x 6 x 102,0	S - - I/S - Cr -  RA/S- Cr -	- 45° - - - 45° - -  - 45° - VS -	22 - III 22 - III  22 - III	06K 109 601 06L 109 601 06D 109 611K 06D 109 611L 06D 109 611T 06E 109 611D 06K 109 611	<b>331162</b>  <b>331117</b> (1)  <b>331144</b> (2)
	[50]	∅ 6 mm				036 109 651A	<b>MK-6H</b>
	IN/EX [4] IN/EX [4] IN/EX [4]	11,04 x 6 x 39,0 11,05 x 6 x 36,0 11,15 x 6 x 36,0	B1 B1 B1			058 103 415	<b>81-33121</b> <b>81-33111</b> <b>81-33118</b>
	[4]					06E109417AA 06E109417N	<b>50 007 657</b>

## 329 82,5

CNSB Euro 6		07.2013 →	B (A)	4	1798 cm <sup>3</sup> 4V	125 kW	(170 PS)	84,10 mm
	IN [2] EX [2]  EX [2] (1) OES specification (2) IAM specification	33,8 x 6 x 104,0 28,0 x 6 x 101,9  28,0 x 6 x 102,0	S - - I/S - Cr -  RA/S- Cr -	- 45° - - - 45° - -  - 45° - VS -	22 - III 22 - III  22 - III	06K 109 601 06L 109 601 06D 109 611K 06D 109 611L 06D 109 611T 06E 109 611D 06K 109 611	<b>331162</b>  <b>331117</b> (1)  <b>331144</b> (2)	
	[50]	∅ 6 mm				036 109 651A	<b>MK-6H</b>	
	IN/EX [4] IN/EX [4] IN/EX [4] EX [4]	11,04 x 6 x 39,0 11,05 x 6 x 36,0 11,15 x 6 x 36,0 11,04 x 6 x 39,0	B1 B1 B1 G2			058 103 415	<b>81-33121</b> <b>81-33111</b> <b>81-33118</b> <b>81-33122</b>	

## 330 82,5

CXBA		07.2013 →	B (A)	4	1798 cm <sup>3</sup> 4V	125 kW	(170 PS)	84,10 mm
CXBB		07.2013 →	B (A)	4	1798 cm <sup>3</sup> 4V	125 kW	(170 PS)	84,10 mm

	IN [2] EX [2]  EX [2] (1) OES specification (2) IAM specification	33,8 x 6 x 104,0 28,0 x 6 x 101,9  28,0 x 6 x 102,0	S - - I/S - Cr -  RA/S- Cr -	- 45° - - - 45° - -  - 45° - VS -	22 - III 22 - III  22 - III	06K 109 601 06L 109 601 06D 109 611K 06D 109 611L 06D 109 611T 06E 109 611D 06K 109 611	<b>331162</b>  <b>331117</b> (1)  <b>331144</b> (2)
	[50]	∅ 6 mm				036 109 651A	<b>MK-6H</b>

Fortsetzung nächste Seite / continued on next page / suite page suivante / continuación página próxima / Продолжение на следующей странице

					Reference	Item No.
	IN/EX [4] 11,04 x 6 x 39,0 IN/EX [4] 11,05 x 6 x 36,0 IN/EX [4] 11,15 x 6 x 36,0	B1 B1 B1			058 103 415	<b>81-33121</b> <b>81-33111</b> <b>81-33118</b>

## 331 82,5

**CULA Euro 6** 11.2013 → 11.2017 B (A) 4 1984 cm<sup>3</sup> 4V 132 kW (180 PS) 9,6 92,80 mm

	[4]				06E109417AA 06E109417N	<b>50 007 657</b>
--	-----	--	--	--	---------------------------	-------------------

## 332 82,5

**CULC** 11.2013 → 09.2018 B (LA) 4 1984 cm<sup>3</sup> 4V 162 kW (220 PS) 92,80 mm

41 501 6..

	IN [2] 33,8 x 6 x 104,0 EX [2] 28,0 x 5,9 x 101,8	S - - RA/S- Cr - Na	- 45° - - - 45° - VS -	22 - III 22 - III	06K 109 601 06L 109 601 06E 109 611K 06K 109 611A 06K 109 611E 079 109 611D 079 109 611F 079 109 611G	<b>331162</b> <b>331160</b>
	[50] Ø 6 mm				036 109 651A	<b>MK-6H</b>
	(1) Lagerbock bearing bracket chevalet support pedestal de cojinete кронштѣйн подшпника				06L103144F 06L103144H	<b>50 007 670</b> (1)
	[4]				06E109417AA 06E109417N	<b>50 007 657</b>

## 333 82,5

**CJXB Euro 6** 11.2013 → B (A) 4 1984 cm<sup>3</sup> 4V 206 kW (280 PS) 92,80 mm

41 533 6..

	IN [2] 33,8 x 6 x 104,0 EX [2] 28,0 x 5,9 x 101,8	S - - RA/S- Cr - Na	- 45° - - - 45° - VS -	22 - III 22 - III	06K 109 601 06L 109 601 06E 109 611K 06K 109 611A 06K 109 611E 079 109 611D 079 109 611F 079 109 611G	<b>331162</b> <b>331160</b>
	[50] Ø 6 mm				036 109 651A	<b>MK-6H</b>
	[8] H 12				04E109423C	<b>50 007 667</b>

## 334 82,5

**CJXC Euro 6** 11.2013 → B (LA) 4 1984 cm<sup>3</sup> 4V 221-265 kW (300-360 PS) 9,3:1 92,80 mm

41 533 6..

Fortsetzung nächste Seite / continued on next page / suite page suivante / continuación página próxima / Продолжение на следующей странице

					Reference	Item No.	
	IN [2] EX [2]  EX [2]  (1) OES specification	33,8 x 6 x 104,0 28,0 x 5,9 x 101,8 28,0 x 6 x 101,9	S - - RA/S- Cr - Na I/S - Cr -	- 45° - - - 45° - VS - - 45° - -	22 - III 22 - III 22 - III	06K 109 601 06L 109 601 06E 109 611K 06K 109 611A 06K 109 611E 079 109 611D 079 109 611F 079 109 611G 06D 109 611K 06D 109 611L 06D 109 611T 06E 109 611D 06K 109 611	<b>331162</b>  <b>331160</b>  <b>331117</b> (1)
	[50]	Ø 6 mm				036 109 651A	<b>MK-6H</b>
	IN/EX [4] IN/EX [4] IN/EX [4] EX [4]	11,04 x 6 x 39,0 11,05 x 6 x 36,0 11,15 x 6 x 36,0 11,04 x 6 x 39,0	B1 B1 B1 G2			058 103 415	<b>81-33121</b> <b>81-33111</b> <b>81-33118</b> <b>81-33122</b>
	[8]	H 12 x 34,5				022 109 423 A 022 109 423 D	<b>50 006 419</b>

### 335 82,5

<b>CJXD Euro 6</b>	12.2016 →	B (LA)	4	1984 cm <sup>3</sup>	4V	213 kW	(290 PS)	92,80 mm
<b>CJXG Euro 6</b>	09.2016 →	B (LA)	4	1984 cm <sup>3</sup>	4V	228 kW	(310 PS)	92,80 mm
<b>CNTA Euro 6</b>	11.2013 →	B (A)	4	1984 cm <sup>3</sup>	4V	155 kW	(211 PS) 9,6	92,80 mm
<b>DJHA Euro 6</b>	12.2016 →	B (LA)	4	1984 cm <sup>3</sup>	4V	228 kW	(310 PS)	92,80 mm
<b>DJHB</b>	12.2016 →	B (LA)	4	1984 cm <sup>3</sup>	4V	213 kW	(290 PS)	92,80 mm
<b>DJHC</b>	04.2017 →	B (LA)	4	1984 cm <sup>3</sup>	4V	206 kW	(280 PS)	92,80 mm
<b>DJJA Euro 6</b>	11.2014 →	B (LA)	4	1984 cm <sup>3</sup>	4V	215 kW	(292 PS) 9,3	92,80 mm
<b>DLBA</b>	03.2017 →	B (A)	4	1984 cm <sup>3</sup>	4V	180 kW	(245 PS)	92,80 mm
<b>DLRA</b>	11.2014 →	B (LA)	4	1984 cm <sup>3</sup>	4V	215 kW	(292 PS) 9,3	92,80 mm
<b>DLRB</b>	04.2018 →	B (LA)	4	1984 cm <sup>3</sup>	4V	200 kW	(272 PS) 9,3	92,80 mm
<b>DNUA Euro 6</b>	04.2018 →	B (A)	4	1984 cm <sup>3</sup>	4V	200 kW	(272 PS)	92,80 mm

41 192 6.., 41 501 6.., 41 533 6..

	IN [2] EX [2]	33,8 x 6 x 104,0 28,0 x 5,9 x 101,8	S - - RA/S- Cr - Na	- 45° - - - 45° - VS -	22 - III 22 - III	06K 109 601 06L 109 601 06E 109 611K 06K 109 611A 06K 109 611E 079 109 611D 079 109 611F 079 109 611G	<b>331162</b>  <b>331160</b>
	[50]	Ø 6 mm				036 109 651A	<b>MK-6H</b>
	(1)	Lagerbock bearing bracket chevalet support pedestal de cojinete кронштейн подшпника				06L103144F 06L103144H	<b>50 007 670</b> (1)

### 336 82,5

<b>CYFB</b>	11.2014 →	B (A)	4	1984 cm <sup>3</sup>	4V	215 kW	(292 PS)	92,80 mm
-------------	-----------	-------	---	----------------------	----	--------	----------	----------

41 533 6..

Fortsetzung nächste Seite / continued on next page / suite page suivante / continuación página próxima / Продолжение на следующей странице

					Reference	Item No.	
	IN [2] EX [2]	33,8 x 6 x 104,0 28,0 x 5,9 x 101,8	S - - RA/S- Cr - Na	- 45° - - - 45° - VS -	22 - III 22 - III	06K 109 601 06L 109 601 06E 109 611K 06K 109 611A 06K 109 611E 079 109 611D 079 109 611F 079 109 611G	<b>331162</b> <b>331160</b>
	[50]	∅ 6 mm				036 109 651A	<b>MK-6H</b>
	IN/EX [4] IN/EX [4] IN/EX [4] EX [4]	11,04 x 6 x 39,0 11,05 x 6 x 36,0 11,15 x 6 x 36,0 11,04 x 6 x 39,0	B1 B1 B1 G2			058 103 415	<b>81-33121</b> <b>81-33111</b> <b>81-33118</b> <b>81-33122</b>

## 337 82,5

<b>DAJA</b>	11.2014 →	B (LA)	4	1798 cm <sup>3</sup>	4V	141-169 kW	(192-230 PS)	9,6	84,20 mm
<b>DEDA</b>	05.2015 →	B (LA)	4	1984 cm <sup>3</sup>	4V	162 kW	(220 PS)	9,6	92,80 mm

41 501 6..., 41 509 6..

	IN [2] EX [2]	33,8 x 6 x 104,0 28,0 x 6 x 101,9	S - - I/S - Cr -	- 45° - - - 45° - -	22 - III 22 - III	06K 109 601 06L 109 601 06D 109 611K 06D 109 611L 06D 109 611T 06E 109 611D 06K 109 611	<b>331162</b> <b>331117</b> (1)
	EX [2] (1) OES specification (2) IAM specification	28,0 x 6 x 102,0	RA/S- Cr -	- 45° - VS -	22 - III		<b>331144</b> (2)
	[50]	∅ 6 mm				036 109 651A	<b>MK-6H</b>
	IN/EX [4] IN/EX [4] IN/EX [4] EX [4]	11,04 x 6 x 39,0 11,05 x 6 x 36,0 11,15 x 6 x 36,0 11,04 x 6 x 39,0	B1 B1 B1 G2			058 103 415	<b>81-33121</b> <b>81-33111</b> <b>81-33118</b> <b>81-33122</b>
	(3) Lagerbock bearing bracket chevalet support pedestal de cojinete кронштјин подшпника					06L103144F 06L103144H	<b>50 007 670</b> (3)

## 338 82,5

<b>DAJB</b>	11.2014 →	B (LA)	4	1798 cm <sup>3</sup>	4V	141 kW	(192 PS)	84,20 mm
-------------	-----------	--------	---	----------------------	----	--------	----------	----------

41 509 6..

	IN [2] EX [2]	33,8 x 6 x 104,0 28,0 x 6 x 101,9	S - - I/S - Cr -	- 45° - - - 45° - -	22 - III 22 - III	06K 109 601 06L 109 601 06D 109 611K 06D 109 611L 06D 109 611T 06E 109 611D 06K 109 611	<b>331162</b> <b>331117</b> (1)
	EX [2] (1) OES specification (2) IAM specification	28,0 x 6 x 102,0	RA/S- Cr -	- 45° - VS -	22 - III		<b>331144</b> (2)

Fortsetzung nächste Seite / continued on next page / suite page suivante / continuación página próxima / Продолжение на следующей странице

					Reference	Item No.
[50]	Ø 6 mm				036 109 651A	<b>MK-6H</b>
IN/EX [4] IN/EX [4] IN/EX [4] EX [4]	11,04 x 6 x 39,0 11,05 x 6 x 36,0 11,15 x 6 x 36,0 11,04 x 6 x 39,0	B1 B1 B1 G2			058 103 415	<b>81-33121</b> <b>81-33111</b> <b>81-33118</b> <b>81-33122</b>
	(3) Lagerbock bearing bracket chevalet support pedestal de cojinete кронштейн подшипника				06L103144F 06L103144H	<b>50 007 670</b> (3)
[8]	H 12 x 34,5				022 109 423 A 022 109 423 D	<b>50 006 419</b>

**339**
**82,5**

**CJSB Euro 6** 12.2014→ B (LA) 4 1798 cm<sup>3</sup> 4V 132 kW (180 PS) 9,6 84,10 mm  
41 509 6..

IN [2] EX [2]  EX [2] (1) OES specification (2) IAM specification	33,8 x 6 x 104,0 28,0 x 6 x 101,9  28,0 x 6 x 102,0	S - - I/S - Cr -  RA/S- Cr -	- 45° - - - 45° - -  - 45° - VS -	22 - III 22 - III  22 - III	06K 109 601 06L 109 601 06D 109 611K 06D 109 611L 06D 109 611T 06E 109 611D 06K 109 611	<b>331162</b> <b>331117</b> (1)  <b>331144</b> (2)
[50]	Ø 6 mm				036 109 651A	<b>MK-6H</b>
IN/EX [4] IN/EX [4] IN/EX [4] EX [4]	11,04 x 6 x 39,0 11,05 x 6 x 36,0 11,15 x 6 x 36,0 11,04 x 6 x 39,0	B1 B1 B1 G2			058 103 415	<b>81-33121</b> <b>81-33111</b> <b>81-33118</b> <b>81-33122</b>
	(3) Lagerbock bearing bracket chevalet support pedestal de cojinete кронштейн подшипника				06L103144F 06L103144H	<b>50 007 670</b> (3)
[4]					06E109417AA 06E109417N	<b>50 007 657</b>

**340**
**82,5**

**CJSA Euro 6** 02.2015→ B (LA) 4 1798 cm<sup>3</sup> 4V 132 kW (180 PS) 9,6 84,10 mm  
41 509 6..

IN [2] EX [2]  EX [2]	33,8 x 6 x 104,0 28,0 x 6 x 101,9  28,0 x 6 x 102,0	S - - I/S - Cr -  RA/S- Cr -	- 45° - - - 45° - -  - 45° - VS -	22 - III 22 - III  22 - III	06K 109 601 06L 109 601 06D 109 611K 06D 109 611L 06D 109 611T 06E 109 611D 06K 109 611	<b>331162</b> <b>331117</b> (1)  <b>331144</b> (2)
--------------------------------	--	---------------------------------------	--	--------------------------------------	---	---

Fortsetzung nächste Seite / continued on next page / suite page suivante / continuación página próxima / Продолжение на следующей странице

					Reference	Item No.
(1) OES specification						
(2) IAM specification						
[50]	∅ 6 mm				036 109 651A	<b>MK-6H</b>
IN/EX [4]	11,04 x 6 x 39,0	B1			058 103 415	<b>81-33121</b> <small>NEW</small>
IN/EX [4]	11,05 x 6 x 36,0	B1				<b>81-33111</b>
IN/EX [4]	11,15 x 6 x 36,0	B1				<b>81-33118</b> <small>NEW</small>
EX [4]	11,04 x 6 x 39,0	G2				<b>81-33122</b> <small>NEW</small>
[4]					06E109417AA 06E109417N	<b>50 007 657</b>

## 341

82,5

**CJSC Euro 6** 02.2015 → B (LA) 4 1798 cm<sup>3</sup> 4V 132 kW (180 PS) 9,6 84,10 mm  
41 509 6..

IN [2]	33,8 x 6 x 104,0	S - -	- 45° - -	22 - III	06K 109 601 06L 109 601	<b>331162</b> <small>NEW</small>
EX [2]	28,0 x 6 x 101,9	I/S - Cr -	- 45° - -	22 - III	06D 109 611K 06D 109 611L 06D 109 611T 06E 109 611D 06K 109 611	<b>331117</b> (1)
(1) OES specification						
[50]	∅ 6 mm				036 109 651A	<b>MK-6H</b>

## 342

82,5

**CZPA Euro 6** 01.2016 → B (A) 4 1984 cm<sup>3</sup> 4V 132 kW (180 PS) 11,65 92,80 mm  
**CZPB Euro 6** 05.2017 → B (A) 4 1984 cm<sup>3</sup> 4V 140 kW (190 PS) 11,65 92,80 mm  
**CZPC Euro 6** 11.2017 → B (A) 4 1984 cm<sup>3</sup> 4V 147 kW (200 PS) 11,65 92,80 mm  
**DKTA Euro 6** 09.2018 → B (LA) 4 1984 cm<sup>3</sup> 4V 169 kW (230 PS) 92,80 mm  
**DKZA Euro 6** 05.2017 → B (A) 4 1984 cm<sup>3</sup> 4V 140 kW (190 PS) 11,65 92,80 mm  
**DNUC** 12.2016 → B (A) 4 1984 cm<sup>3</sup> 4V 213 kW (290 PS) 9,3 92,80 mm  
41 192 6..

					06L103144F 06L103144H	<b>50 007 670</b> (1)
(1) Lagerbock bearing bracket chevalet support pedestal de cojinete кронштейн подпшника						

## 343

82,5

**CEAA** B (A) 4 1798 cm<sup>3</sup> 4V 118 kW (160 PS) 84,20 mm  
**CGMA** B (A) 4 1984 cm<sup>3</sup> 4V 147 kW (200 PS) 92,80 mm  
40 247 6.., 40 251 6..

IN [2]	33,9 x 6 x 104,0	S - -	- 45° - VS -	22 - III	06D 109 601M 06J 106 601H 079 109 601B 079 109 601E	<b>331125</b>
EX [2]	28,0 x 6 x 101,9	RA/S- Cr - Na	- 45° - VS -	22 - III	06D 109 611 P 06D 109 611H 06J 109 611D	<b>331126</b>
[50]	∅ 6 mm				036 109 651A	<b>MK-6H</b>



					Reference	Item No.	
<b>344</b>		<b>82,5</b>					
<b>CFEA</b>	10.1998 →	AB (NA) 4	1984 cm <sup>3</sup> 2V	85-88 kW (116-120 PS)	92,80 mm		
	IN [2]	28,1 x 6 x 99,3	S - -	- 45° - -	22 - III	03L 109 601 04L 109 601B	<b>331131</b>
	EX [2]	26,0 x 6 x 99,1	RA/S- -	- 45° - VS -	22 - III	03L 109 611 04L 109 611B 04L 109 611C	<b>331132</b>
	[50]	Ø 6 mm				036 109 651A	<b>MK-6H</b>
	IN/EX [4]	10,06 x 6 x 42,0	B1				<b>81-33112</b>
<b>345</b>		<b>82,5</b>					
<b>BEF</b>	04.2002 →	G (NA) 4	1984 cm <sup>3</sup> 2V	43 kW (58 PS)	92,80 mm		
	IN [2]	39,5 x 7 x 91,9	S - -	- 45° - -	22 - III	06A 109 601E 078 109 601A 078 109 601B 078 109 601E 078 109 601F	<b>33403</b>
	EX [2]	33,0 x 7 x 91,2	A/S - -	- 45° - VS -	22 - III	048 109 611B 078 109 611C	<b>33416</b>
	IN/EX [4]	12,08/15 x 7 x 36,5	B1			037 103 415 037 103 419 B	<b>81-33103</b>
	IN/EX [4]	12,25/15 x 7 x 36,5	B1				<b>81-33104</b>
<b>346</b>		<b>82,5</b>					
<b>CBSA</b>		G (NA) 4	1984 cm <sup>3</sup> 2V	37 kW (50 PS)	92,80 mm		
	IN [2]	39,5 x 7 x 91,9	S - -	- 45° - -	22 - III	06A 109 601E 078 109 601A 078 109 601B 078 109 601E 078 109 601F	<b>33403</b>
	EX [2]	33,0 x 7 x 91,2	A/S - -	- 45° - VS -	22 - III	048 109 611B 078 109 611C	<b>33416</b>
	[50]	Ø 7 mm				021 109 651	<b>MK-7H</b>
	IN/EX [4]	12,08/15 x 7 x 36,5	B1			037 103 415 037 103 419 B	<b>81-33103</b>
	IN/EX [4]	12,25/15 x 7 x 36,5	B1				<b>81-33104</b>
<b>347</b>		<b>83</b>					
<b>H</b>	02.1962 → 11.1973	B (NA) 4	1493 cm <sup>3</sup> 2V	32-33 kW (44-45 PS) 7,8:1	69,00 mm		
<b>L</b>	09.1966 → 07.1970	B (NA) 4	1493 cm <sup>3</sup> 2V	29-32 kW (40-44 PS)	69,00 mm		
	IN [2]	35,5 x 8 x 111,7	S - -	- 45° - -	22 - III	311 109 601	<b>33009</b>
	EX [2]	30,0 x 9 x 111,9	A/S - Cr -	- 45° - VS -	22 - III	043 109 611	<b>33016</b>
	[50]	Ø 8 mm				113 109 651 A 400 501 068	<b>MK-8H</b>
	[50]	Ø 9 mm					<b>MK-9H</b>
<b>348</b>		<b>83</b>					
<b>BMK</b>	09.2004 → 05.2007	D (LA) 6	2967 cm <sup>3</sup> 4V	165 kW (224 PS) 17	91,40 mm		
	IN [2]	28,6 x 6 x 99,3	S - -	- 45° - -	22 - III	059 109 601G	<b>331133</b>
	EX [2]	26,7 x 6 x 99,3	A/S - -	- 45° - VS -	22 - III	059 109 611H 059 109 611K 059 109 611M 059 109 611Q	<b>331134</b>

Fortsetzung nächste Seite / continued on next page / suite page suivante / continuación página próxima / Продолжение на следующей странице

					Reference	Item No.
[50]	Ø 6 mm				036 109 651A	<b>MK-6H</b>
IN/EX [4] IN/EX [4]	10,07 x 6 x 36,0 10,12 x 6 x 36,0	B1 B1				<b>81-3323</b> <b>81-3324</b>
	ES AS ES  AS				059 109 009 BK 059 109 022 BE 059 109 021 BH 059 109 021 BL 059 109 021 EE 059 109 009 AJ 059 109 009 BL	<b>50 007 004</b> (1) <b>50 007 005</b> (1) <b>50 007 006</b> (2)  <b>50 007 008</b> (2)
	(1) für Zylinder/for cylinder/pour cylindre/para cilindro/для цилиндров 1-3 / Schalenhartguss/chilled cast iron/pièce moulée trempée en surface/fundición en coquilla/Отливка с отбелсным поверхностным слоем					
	(2) für Zylinder/for cylinder/pour cylindre/para cilindro/для цилиндров 4-6 / Schalenhartguss/chilled cast iron/pièce moulée trempée en surface/fundición en coquilla/Отливка с отбелсным поверхностным слоем					
[8]	H 12 x 32,6 x 32,6				059 109 521 G	<b>50 006 420</b>
[4]					059 109 417 A 059 109 417 B 059 109 417 C 059 109 417 F 059 109 417 G 059109417J	<b>50 006 171</b>

## 349

**83**

<b>BKS</b>	11.2004 → 05.2010	D (LA)	6	2967 cm <sup>3</sup>	4V	165 kW	(224 PS) 17	91,40 mm
<b>BUN</b>	04.2006 → 05.2010	D (LA)	6	2967 cm <sup>3</sup>	4V	155 kW	(211 PS) 17	91,40 mm

IN [2] EX [2]	28,6 x 6 x 99,3 26,7 x 6 x 99,3	S - - A/S - -	- 45° - - - 45° - VS -	22 - III 22 - III	059 109 601G 059 109 611H 059 109 611K 059 109 611M 059 109 611Q	<b>331133</b> <b>331134</b>
[50]	Ø 6 mm				036 109 651A	<b>MK-6H</b>
IN/EX [4] IN/EX [4]	10,07 x 6 x 36,0 10,12 x 6 x 36,0	B1 B1				<b>81-3323</b> <b>81-3324</b>
	ES AS ES  AS				059 109 009 BK 059 109 022 BE 059 109 021 BH 059 109 021 BL 059 109 021 EE 059 109 009 AJ 059 109 009 BL	<b>50 007 004</b> (1) <b>50 007 005</b> (1) <b>50 007 006</b> (2)  <b>50 007 008</b> (2)
	(1) für Zylinder/for cylinder/pour cylindre/para cilindro/для цилиндров 1-3 / Schalenhartguss/chilled cast iron/pièce moulée trempée en surface/fundición en coquilla/Отливка с отбелсным поверхностным слоем					
	(2) für Zylinder/for cylinder/pour cylindre/para cilindro/для цилиндров 4-6 / Schalenhartguss/chilled cast iron/pièce moulée trempée en surface/fundición en coquilla/Отливка с отбелсным поверхностным слоем					
[8]	H 12 x 32,6 x 32,6				059 109 521 G	<b>50 006 420</b>

## 350

**83**

<b>CATA</b>	11.2004 → 03.2018	D (LA)	6	2967 cm <sup>3</sup>	4V	165 kW	(224 PS) 16,8	91,40 mm
-------------	-------------------	--------	---	----------------------	----	--------	---------------	----------

Fortsetzung nächste Seite / continued on next page / suite page suivante / continuación página próxima / Продолжение на следующей странице

					Reference	Item No.
IN [2] EX [2]	28,6 x 6 x 99,3 26,7 x 6 x 99,3	S - - A/S - -	- 45° - - - 45° - VS -	22 - III 22 - III	059 109 601G 059 109 611H 059 109 611K 059 109 611M 059 109 611Q	<b>331133</b> <b>331134</b>
[50]	∅ 6 mm				036 109 651A	<b>MK-6H</b>
IN/EX [4] IN/EX [4]	10,07 x 6 x 36,0 10,12 x 6 x 36,0	B1 B1				<b>81-3323</b> <b>81-3324</b>
	ES ES				059 109 021 DS 059 109 009 AM 059 109 009 BP 059 109 009 DC 059 109 021 BT 059 109 021 CB 059 109 021 DM 059 109 022 BE	<b>50 007 002</b> (1) <b>50 007 003</b> (2)  <b>50 007 005</b> (2)
	(1) für Zylinder/for cylinder/pour cylindre/para cilindro/для цилиндров 4-6 / Schalenhartguss/chilled cast iron/pièce moulée trempée en surface/fundición en coquilla/Отливка с отбелнным поверхностным слоем (2) für Zylinder/for cylinder/pour cylindre/para cilindro/для цилиндров 1-3 / Schalenhartguss/chilled cast iron/pièce moulée trempée en surface/fundición en coquilla/Отливка с отбелнным поверхностным слоем					
[8]	H 12 x 32,5				03L 109 521 03L 109 521 A	<b>50 006 490</b>
[4]					059 109 417 A 059 109 417 B 059 109 417 C 059 109 417 F 059 109 417 G 059109417J	<b>50 006 171</b>

**351**
**83**

<b>CASA</b>	11.2007 → 03.2018	D (LA)	6	2967 cm <sup>3</sup>	4V	176 kW	(240 PS)	16,8:1	91,40 mm
<b>CASB</b>	04.2006 → 05.2010	D (LA)	6	2967 cm <sup>3</sup>	4V	155 kW	(211 PS)	16,8	91,40 mm
<b>CEXA</b>	11.2008 → 03.2016	D (A)	6	2967 cm <sup>3</sup>	4V	176 kW	(240 PS)		91,40 mm

IN [2] EX [2]	28,6 x 6 x 99,3 26,7 x 6 x 99,3	S - - A/S - -	- 45° - - - 45° - VS -	22 - III 22 - III	059 109 601G 059 109 611H 059 109 611K 059 109 611M 059 109 611Q	<b>331133</b> <b>331134</b>
[50]	∅ 6 mm				036 109 651A	<b>MK-6H</b>
IN/EX [4] IN/EX [4]	10,07 x 6 x 36,0 10,12 x 6 x 36,0	B1 B1				<b>81-3323</b> <b>81-3324</b>
	ES AS AS				059 109 009 BK 059 109 022 BE 059 109 009 AJ 059 109 009 BL 059 109 021 DN	<b>50 007 004</b> (1) <b>50 007 005</b> (1) <b>50 007 008</b> (2)  <b>50 007 015</b> (2)
	(1) für Zylinder/for cylinder/pour cylindre/para cilindro/для цилиндров 1-3 / Schalenhartguss/chilled cast iron/pièce moulée trempée en surface/fundición en coquilla/Отливка с отбелнным поверхностным слоем (2) für Zylinder/for cylinder/pour cylindre/para cilindro/для цилиндров 4-6 / Schalenhartguss/chilled cast iron/pièce moulée trempée en surface/fundición en coquilla/Отливка с отбелнным поверхностным слоем					

Fortsetzung nächste Seite / continued on next page / suite page suivante / continuación página próxima / Продолжение на следующей странице

					Reference	Item No.
[8]	H 12 x 32,5				03L 109 521 03L 109 521 A	<b>50 006 490</b>
[4]					059 109 417 A 059 109 417 B 059 109 417 C 059 109 417 F 059 109 417 G 059109417J	<b>50 006 171</b>

**352** **83**
**CARA** 06.2007 → 11.2008 D (A) 6 2967 cm<sup>3</sup> 4V 171 kW (233 PS) 17:1 91,40 mm

	IN [2] EX [2]	28,6 x 6 x 99,3 26,7 x 6 x 99,3	S - - A/S - -	- 45° - - - 45° - VS -	22 - III 22 - III	059 109 601G 059 109 611H 059 109 611K 059 109 611M 059 109 611Q	<b>331133</b> <b>331134</b>
[50]		∅ 6 mm				036 109 651A	<b>MK-6H</b>
	IN/EX [4] IN/EX [4]	10,07 x 6 x 36,0 10,12 x 6 x 36,0	B1 B1				<b>81-3323</b> <b>81-3324</b>
		ES AS AS  ES				059 109 009 BK 059 109 022 BE 059 109 009 AJ 059 109 009 BL 059 109 021 DN	<b>50 007 004</b> (1) <b>50 007 005</b> (1) <b>50 007 008</b> (2)  <b>50 007 015</b> (2)
	(1)	für Zylinder/for cylinder/pour cylindre/para cilindro/для цилиндров 1-3 / Schalenhartguss/chilled cast iron/pièce moulée trempée en surface/fundición en coquilla/Отливка с отбеленным поверхностным слоем					
	(2)	für Zylinder/for cylinder/pour cylindre/para cilindro/для цилиндров 4-6 / Schalenhartguss/chilled cast iron/pièce moulée trempée en surface/fundición en coquilla/Отливка с отбеленным поверхностным слоем					
[4]						059 109 417 A 059 109 417 B 059 109 417 C 059 109 417 F 059 109 417 G 059109417J	<b>50 006 171</b>

**353** **83**
**CASC** 11.2007 → 05.2010 D (LA) 6 2967 cm<sup>3</sup> 4V 176 kW (240 PS) 16,8:1 91,40 mm

	IN [2] EX [2]	28,6 x 6 x 99,3 26,7 x 6 x 99,3	S - - A/S - -	- 45° - - - 45° - VS -	22 - III 22 - III	059 109 601G 059 109 611H 059 109 611K 059 109 611M 059 109 611Q	<b>331133</b> <b>331134</b>
[50]		∅ 6 mm				036 109 651A	<b>MK-6H</b>
	IN/EX [4] IN/EX [4]	10,07 x 6 x 36,0 10,12 x 6 x 36,0	B1 B1				<b>81-3323</b> <b>81-3324</b>
		ES AS ES				059 109 009 BK 059 109 022 BE 059 109 021 DN	<b>50 007 004</b> (1) <b>50 007 005</b> (1) <b>50 007 015</b> (2)
	(1)	für Zylinder/for cylinder/pour cylindre/para cilindro/для цилиндров 1-3 / Schalenhartguss/chilled cast iron/pièce moulée trempée en surface/fundición en coquilla/Отливка с отбеленным поверхностным слоем					

Fortsetzung nächste Seite / continued on next page / suite page suivante / continuación página próxima / Продолжение на следующей странице

					Reference	Item No.
	(2)	für Zylinder/for cylinder/pour cylindre/para cilindro/для цилиндров 4-6 / Schalenhartguss/chilled cast iron/pièce moulée trempée en surface/fundición en coquilla/Отливка с отбеленным поверхностным слоем				
	[4]				059 109 417 A 059 109 417 B 059 109 417 C 059 109 417 F 059 109 417 G 059109417J	<b>50 006 171</b>

<b>354</b> <b>83</b>								
CEZA		12.2007 →	D (A)	6	2967 cm <sup>3</sup> 4V	195 kW (265 PS)	91,40 mm	
	IN [2] EX [2]	28,6 x 6 x 99,3 26,7 x 6 x 99,3	S - - A/S - -		- 45° - - - 45° - VS -	22 - III 22 - III	059 109 601G 059 109 611H 059 109 611K 059 109 611M 059 109 611Q	<b>331133</b> <b>331134</b>
	[50]	Ø 6 mm					036 109 651A	<b>MK-6H</b>
	IN/EX [4] IN/EX [4] IN/EX [4]	10,06 x 6 x 42,0 10,07 x 6 x 36,0 10,12 x 6 x 36,0	B1 B1 B1					<b>81-33112</b> <b>81-3323</b> <b>81-3324</b>

<b>355</b> <b>83</b>								
CARB		11.2008 → 03.2016	D (A)	6	2967 cm <sup>3</sup> 4V	176 kW (239 PS) 17:1	91,40 mm	
	IN/EX [4] IN/EX [4]	10,07 x 6 x 36,0 10,12 x 6 x 36,0	B1 B1					<b>81-3323</b> <b>81-3324</b>

<b>356</b> <b>83</b>								
CASD Euro 5		01.2010 → 03.2018	D (A)	6	2967 cm <sup>3</sup> 4V	150 kW (204 PS)	91,40 mm	
	IN [2] EX [2]	28,6 x 6 x 99,3 26,7 x 6 x 99,3	S - - A/S - -		- 45° - - - 45° - VS -	22 - III 22 - III	059 109 601G 059 109 611H 059 109 611K 059 109 611M 059 109 611Q	<b>331133</b> <b>331134</b>
	[50]	Ø 6 mm					036 109 651A	<b>MK-6H</b>
	IN/EX [4] IN/EX [4]	10,07 x 6 x 36,0 10,12 x 6 x 36,0	B1 B1					<b>81-3323</b> <b>81-3324</b>
		ES AS ES					059 109 009 BK 059 109 022 BE 059 109 021 DN	<b>50 007 004</b> (1) <b>50 007 005</b> (1) <b>50 007 015</b> (2)
	(1)	für Zylinder/for cylinder/pour cylindre/para cilindro/для цилиндров 1-3 / Schalenhartguss/chilled cast iron/pièce moulée trempée en surface/fundición en coquilla/Отливка с отбеленным поверхностным слоем						
	(2)	für Zylinder/for cylinder/pour cylindre/para cilindro/для цилиндров 4-6 / Schalenhartguss/chilled cast iron/pièce moulée trempée en surface/fundición en coquilla/Отливка с отбеленным поверхностным слоем						

<b>357</b> <b>83</b>							
CJMA		01.2010 → 03.2018	D (A)	6	2967 cm <sup>3</sup> 4V	150 kW (204 PS)	91,40 mm
CNRB		01.2010 → 03.2018	D (LA)	6	2967 cm <sup>3</sup> 4V	176 kW (240 PS)	91,40 mm
CRCA		05.2011 → 03.2018	D (LA)	6	2967 cm <sup>3</sup> 4V	180 kW (245 PS)	91,40 mm

Fortsetzung nächste Seite / continued on next page / suite page suivante / continuación página próxima / Продолжение на следующей странице

					Reference	Item No.
IN [2]	28,1 x 6 x 99,3	S - -	- 45° - -	22 - III	03L 109 601 04L 109 601B	<b>331131</b>
IN [2]	28,6 x 6 x 99,3	S - -	- 45° - -	22 - III	059 109 601G	<b>331133</b>
EX [2]	24,5 x 6 x 99,1	A/S - -	- 45° - VS -	22 - III	03L 109 611A 04L 109 611A	<b>331154</b>
EX [2]	26,0 x 6 x 99,1	RA/S- -	- 45° - VS -	22 - III	03L 109 611 04L 109 611B 04L 109 611C	<b>331132</b>
[50]	∅ 6 mm				036 109 651A	<b>MK-6H</b>
IN/EX [4]	10,06 x 6 x 42,0	B1				<b>81-33112</b>
IN/EX [4]	10,07 x 6 x 36,0	B1				<b>81-3323</b>
[8]	H 12 x 32,5				03L 109 521 03L 109 521 A	<b>50 006 490</b>
[4]					059 109 417 A 059 109 417 B 059 109 417 C 059 109 417 F 059 109 417 G 059109417J	<b>50 006 171</b>

## 358 83

**CKDA Euro 5** 01.2010 → 03.2018 D (LA) 8 4134 cm<sup>3</sup> 4V 250 kW (340 PS) 16,4 95,50 mm

IN [2]	28,6 x 6 x 99,3	S - -	- 45° - -	22 - III	059 109 601G	<b>331133</b>
EX [2]	26,7 x 6 x 99,3	A/S - -	- 45° - VS -	22 - III	059 109 611H 059 109 611K 059 109 611M 059 109 611Q	<b>331134</b>
[50]	∅ 6 mm				036 109 651A	<b>MK-6H</b>
IN/EX [4]	10,07 x 6 x 36,0	B1				<b>81-3323</b>
IN/EX [4]	10,12 x 6 x 36,0	B1				<b>81-3324</b>
[8]	H 12 x 32,5				03L 109 521 03L 109 521 A	<b>50 006 490</b>
[4]					059 109 417 A 059 109 417 B 059 109 417 C 059 109 417 F 059 109 417 G 059109417J	<b>50 006 171</b>

## 359 83

**CRCD** 01.2010 → 03.2018 D (A) 6 2967 cm<sup>3</sup> 4V 150 kW (204 PS) 91,40 mm  
**CVVA** 09.2014 → 03.2018 D (A) 6 2967 cm<sup>3</sup> 4V 193 kW (262 PS) 16,8 91,40 mm  
**CVWA** 01.2010 → 03.2018 D (A) 6 2967 cm<sup>3</sup> 4V 150 kW (204 PS) 16,8 91,40 mm

IN [2]	28,6 x 6 x 99,3	S - -	- 45° - -	22 - III	059 109 601G	<b>331133</b>
EX [2]	24,5 x 6 x 99,1	A/S - -	- 45° - VS -	22 - III	03L 109 611A 04L 109 611A	<b>331154</b>
[50]	∅ 6 mm				036 109 651A	<b>MK-6H</b>
IN/EX [4]	10,07 x 6 x 36,0	B1				<b>81-3323</b>

## 360 83

**CJGD** 05.2011 → 03.2018 D (LA) 6 2967 cm<sup>3</sup> 4V 180 kW (245 PS) 91,40 mm

Fortsetzung nächste Seite / continued on next page / suite page suivante / continuación página próxima / Продолжение на следующей странице



					Reference	Item No.
IN [2]	28,1 x 6 x 99,3	S - -	- 45° - -	22 - III	03L 109 601 04L 109 601B	<b>331131</b>
IN [2]	28,6 x 6 x 99,3	S - -	- 45° - -	22 - III	059 109 601G	<b>331133</b>
EX [2]	26,0 x 6 x 99,1	RA/S- -	- 45° - VS -	22 - III	03L 109 611 04L 109 611B 04L 109 611C	<b>331132</b>
[50]	Ø 6 mm				036 109 651A	<b>MK-6H</b>
IN/EX [4]	10,06 x 6 x 42,0	B1				<b>81-33112</b>
IN/EX [4]	10,07 x 6 x 36,0	B1				<b>81-3323</b>
[8]	H 12 x 32,5				03L 109 521 03L 109 521 A	<b>50 006 490</b>
[4]					059 109 417 A 059 109 417 B 059 109 417 C 059 109 417 F 059 109 417 G 059109417J	<b>50 006 171</b>

## 361

<b>BSP</b>		D (LA)	6	2967 cm <sup>3</sup>	4V	165 kW	(225 PS)	17:1	91,40 mm
<b>CEXB Euro 5</b>	11.2013 → 03.2016	D (A)	6	2967 cm <sup>3</sup>	4V	180 kW	(245 PS)		91,40 mm

IN [2]	28,6 x 6 x 99,3	S - -	- 45° - -	22 - III	059 109 601G	<b>331133</b>
EX [2]	26,7 x 6 x 99,3	A/S - -	- 45° - VS -	22 - III	059 109 611H 059 109 611K 059 109 611M 059 109 611Q	<b>331134</b>
[50]	Ø 6 mm				036 109 651A	<b>MK-6H</b>
IN/EX [4]	10,07 x 6 x 36,0	B1				<b>81-3323</b>
IN/EX [4]	10,12 x 6 x 36,0	B1				<b>81-3324</b>

## 362

<b>AXJ</b>	04.2000 → 05.2001	B (NA)	6	3189 cm <sup>3</sup>	4V	165 kW	(224 PS)	10,8	95,90 mm
<b>BAN</b>	04.2002 → 12.2005	B (NA)	12	5998 cm <sup>3</sup>	4V	309 kW	(420 PS)	10,75:1	90,20 mm

IN [2]	31,0 x 6 x 102,1	S - -	- 45° - -	22 - III	022 109 601 E	<b>331041</b>
IN [2]	31,0 x 6 x 136,1	S - -	- 45° - -	22 - III	022 109 601F	<b>331135</b>
EX [2]	27,0 x 6 x 102,5	RA/S- Cr -	- 45° - VS -	22 - III	022 109 611B	<b>331136</b>
EX [2]	27,0 x 6 x 136,4	A/S - -	- 45° - VS -	22 - III	022 109 611 C	<b>331042</b>
[50]	Ø 6 mm				036 109 651A	<b>MK-6H</b>
[4]					022 109 417 C 022 109 417 E	<b>50 006 144</b>

## 363

<b>BDN</b>	09.2001 → 09.2004	B (NA)	8	3999 cm <sup>3</sup>	4V	202 kW	(275 PS)	10,8:1	90,20 mm
<b>BDP</b>	09.2001 → 09.2004	B (NA)	8	3999 cm <sup>3</sup>	4V	202 kW	(275 PS)	10,8:1	90,20 mm

IN/EX [4]	10,07 x 6 x 36,0	B1				<b>81-3323</b>
IN/EX [4]	10,12 x 6 x 36,0	B1				<b>81-3324</b>

					Reference	Item No.		
<b>364</b>	84							
<b>BDL</b>	04.2003 → 11.2009	B (NA)	6	3189 cm <sup>3</sup>	4V	170 kW (231 PS)	11,3	95,90 mm
<b>BKK</b>	08.2003 → 12.2009	B (NA)	6	3189 cm <sup>3</sup>	4V	173 kW (235 PS)	11,3:1	95,90 mm
<b>BKL</b>	04.2002 → 11.2008	B (NA)	6	3189 cm <sup>3</sup>	4V	177 kW (241 PS)	10,85	95,90 mm
<b>BML</b>	09.2002 → 06.2005	B (NA)	6	3189 cm <sup>3</sup>	4V	177 kW (241 PS)	11,3	95,90 mm
<b>BMX</b>	10.2002 → 11.2006	B (NA)	6	3189 cm <sup>3</sup>	4V	162 kW (220 PS)	11,3	95,90 mm
<b>BRJ</b>	10.2002 → 11.2006	B (NA)	6	3189 cm <sup>3</sup>	4V	162 kW (220 PS)	10,8	95,90 mm
<b>BRK</b>	02.2004 → 11.2008	B (NA)	6	3189 cm <sup>3</sup>	4V	177 kW (241 PS)	10,85	95,90 mm
<b>BUB</b>	11.2005 → 05.2009	B (NA)	6	3189 cm <sup>3</sup>	4V	184 kW (250 PS)	10,85	95,90 mm
	IN [2]	33,2 x 6 x 102,4	S - -	- 45° - -	22 - III	022 109 601 AJ 022 109 601G		<b>331127</b>
	IN [2]	33,2 x 6 x 136,3	S - -	- 45° - -	22 - III	022 109 601 AK 022 109 601H		<b>331128</b>
	EX [2]	30,2 x 6 x 102,2	RA/S- -	- 45° - VS -	22 - III	022 109 611 AA 022 109 611N 03H 109 611D		<b>331129</b>
	EX [2]	30,2 x 6 x 136,1	RA/S- -	- 45° - VS -	22 - III	022 109 611 AB 022 109 611M 022 109 611P 03H 109 611E		<b>331130</b>
	[50]	∅ 6 mm				036 109 651A		<b>MK-6H</b>
	IN [4]	10,06 x 6 x 44,0	B1					<b>81-33119</b> <small>NEW</small>
	EX [4]	10,06 x 6 x 65,0	B1					<b>81-33120</b> <small>NEW</small>
	[8]	H 12 x 34,5				022 109 423 B 022 109 423 C		<b>50 006 491</b>
	[4]					022 109 417 C 022 109 417 E		<b>50 006 144</b>
<b>365</b>	84							
<b>AYT</b>	04.2002 → 05.2005	B (NA)	6	3189 cm <sup>3</sup>	4V	177 kW (241 PS)	11,25	95,90 mm
<b>AZZ</b>	10.2002 → 11.2006	B (NA)	6	3189 cm <sup>3</sup>	4V	162 kW (220 PS)	11	95,90 mm
<b>BAA</b>		B (NA)	6	3189 cm <sup>3</sup>	4V	162 kW (220 PS)	11,3	95,90 mm
<b>BFH</b>	09.2002 → 06.2005	B (NA)	6	3189 cm <sup>3</sup>	4V	177 kW (241 PS)	11,3	95,90 mm
<b>BKJ</b>	05.2003 → 11.2006	B (NA)	6	3189 cm <sup>3</sup>	4V	162 kW (220 PS)	11	95,90 mm
	IN [2]	33,2 x 6 x 102,4	S - -	- 45° - -	22 - III	022 109 601 AJ 022 109 601G		<b>331127</b>
	IN [2]	33,2 x 6 x 136,3	S - -	- 45° - -	22 - III	022 109 601 AK 022 109 601H		<b>331128</b>
	EX [2]	30,2 x 6 x 102,2	RA/S- -	- 45° - VS -	22 - III	022 109 611 AA 022 109 611N 03H 109 611D		<b>331129</b>
	EX [2]	30,2 x 6 x 136,1	RA/S- -	- 45° - VS -	22 - III	022 109 611 AB 022 109 611M 022 109 611P 03H 109 611E		<b>331130</b>
	[50]	∅ 6 mm				036 109 651A		<b>MK-6H</b>
	IN [4]	10,06 x 6 x 44,0	B1					<b>81-33119</b> <small>NEW</small>
	EX [4]	10,06 x 6 x 65,0	B1					<b>81-33120</b> <small>NEW</small>
	[8]	H 12 x 34,5				022 109 423 B 022 109 423 C		<b>50 006 491</b>
<b>366</b>	84							
<b>BMV</b>	10.2002 → 11.2006	B (NA)	6	3189 cm <sup>3</sup>	4V	162-177 kW (220-241 PS)	11,3	95,90 mm

Fortsetzung nächste Seite / continued on next page / suite page suivante / continuación página próxima / Продолжение на следующей странице

					Reference	Item No.
	IN [2] 33,2 x 6 x 102,4	S - -	- 45° - -	22 - III	022 109 601 AJ 022 109 601G	<b>331127</b>
	IN [2] 33,2 x 6 x 136,3	S - -	- 45° - -	22 - III	022 109 601 AK 022 109 601H	<b>331128</b>
	EX [2] 30,2 x 6 x 102,2	RA/S- -	- 45° - VS -	22 - III	022 109 611 AA 022 109 611N 03H 109 611D	<b>331129</b>
	EX [2] 30,2 x 6 x 136,1	RA/S- -	- 45° - VS -	22 - III	022 109 611 AB 022 109 611M 022 109 611P 03H 109 611E	<b>331130</b>
	[50] Ø 6 mm				036 109 651A	<b>MK-6H</b>
	IN [4] EX [4] 10,06 x 6 x 44,0 10,06 x 6 x 65,0	B1 B1				<b>81-33119</b> <b>81-33120</b>
	ES AS (1) (ST)				03G 109 101 B 03G 109 101A 03G 109 102B	<b>50 007 575</b> (1) <b>50 007 576</b> (1)
	[8] H 12 x 34,5				022 109 423 B 022 109 423 C	<b>50 006 491</b>
	[4]				022 109 417 C 022 109 417 E	<b>50 006 144</b>

## 367

**84**

<b>CBRA</b>	11.2005 → 05.2009	B (NA)	6	3189 cm <sup>3</sup>	4V	184 kW	(250 PS)	10,85	95,90 mm
<b>CFLA</b>	11.2003 → 12.2009	B (NA)	6	3189 cm <sup>3</sup>	4V	173 kW	(235 PS)		95,90 mm
	IN [2] 33,2 x 6 x 102,4	S - -	- 45° - -	22 - III	022 109 601 AJ 022 109 601G	<b>331127</b>			
	IN [2] 33,2 x 6 x 136,3	S - -	- 45° - -	22 - III	022 109 601 AK 022 109 601H	<b>331128</b>			
	EX [2] 30,2 x 6 x 102,2	RA/S- -	- 45° - VS -	22 - III	022 109 611 AA 022 109 611N 03H 109 611D	<b>331129</b>			
	EX [2] 30,2 x 6 x 136,1	RA/S- -	- 45° - VS -	22 - III	022 109 611 AB 022 109 611M 022 109 611P 03H 109 611E	<b>331130</b>			
	[50] Ø 6 mm				036 109 651A	<b>MK-6H</b>			
	IN [4] EX [4] 10,06 x 6 x 44,0 10,06 x 6 x 65,0	B1 B1				<b>81-33119</b> <b>81-33120</b>			
	[4]				022 109 417 C 022 109 417 E	<b>50 006 144</b>			

## 368

**84**

<b>BJN</b>	08.2004 → 05.2010	B (NA)	12	5998 cm <sup>3</sup>	4V	331 kW	(450 PS)	10.7:1	90,20 mm
<b>BRN</b>	05.2005 → 03.2016	B (NA)	12	5998 cm <sup>3</sup>	4V	331 kW	(450 PS)	10,8:1	90,20 mm
<b>BTT</b>	05.2005 → 03.2016	B (NA)	12	5998 cm <sup>3</sup>	4V	331 kW	(450 PS)	10,8:1	90,20 mm
<b>CFRA</b>	08.2004 → 05.2010	B (NA)	12	5998 cm <sup>3</sup>	4V	331 kW	(450 PS)		90,20 mm
	IN [2] 31,0 x 6 x 102,1	S - -	- 45° - -	22 - III	022 109 601 E	<b>331041</b>			
	IN [2] 31,0 x 6 x 136,1	S - -	- 45° - -	22 - III	022 109 601F	<b>331135</b>			
	EX [2] 27,0 x 6 x 102,5	RA/S- Cr -	- 45° - VS -	22 - III	022 109 611B	<b>331136</b>			
	EX [2] 27,0 x 6 x 136,4	A/S - -	- 45° - VS -	22 - III	022 109 611 C	<b>331042</b>			

Fortsetzung nächste Seite / continued on next page / suite page suivante / continuación página próxima / Продолжение на следующей странице

					Reference	Item No.
[50]	Ø 6 mm				036 109 651A	<b>MK-6H</b>
[8]	H 12 x 34,5				022 109 423 B 022 109 423 C	<b>50 006 491</b>
[4]					022 109 417 C 022 109 417 E	<b>50 006 144</b>

## 369

**84**
**CPFA**

04.2012 → 03.2016

**B**

(NA)

**6**

 2975 cm<sup>3</sup> 4V

184 kW

(250 PS)

11,4 89,50 mm

IN [2]	33,2 x 6 x 102,4	S - -	- 45° - -	22 - III	022 109 601 AJ 022 109 601G	<b>331127</b>
IN [2]	33,2 x 6 x 136,3	S - -	- 45° - -	22 - III	022 109 601 AK 022 109 601H	<b>331128</b>
EX [2]	30,2 x 6 x 102,2	RA/S- -	- 45° - VS -	22 - III	022 109 611 AA 022 109 611N 03H 109 611D	<b>331129</b>
EX [2]	30,2 x 6 x 136,1	RA/S- -	- 45° - VS -	22 - III	022 109 611 AB 022 109 611M 022 109 611P 03H 109 611E	<b>331130</b>
[50]	Ø 6 mm				036 109 651A	<b>MK-6H</b>
IN [4]	10,06 x 6 x 44,0	B1				<b>81-33119</b> <small>NEW</small>
EX [4]	10,06 x 6 x 65,0	B1				<b>81-33120</b> <small>NEW</small>

## 370

**84,5**
**BAR**

06.2006 → 05.2010

**B**

(NA)

**8**

 4163 cm<sup>3</sup> 4V

231-257 kW

(314-350 PS)

12,5:1 92,80 mm

IN [2]	33,9 x 6 x 104,0	S - -	- 45° - -	22 - III	06D 109 601K 06E 109 601E 06E 109 601F	<b>331116</b>
EX [2]	28,0 x 6 x 101,9	RA/S- Cr - Na	- 45° - VS -	22 - III	06D 109 611 P 06D 109 611H 06J 109 611D	<b>331126</b>
[50]	Ø 6 mm				036 109 651A	<b>MK-6H</b>
IN/EX [4]	11,04 x 6 x 39,0	B1				<b>81-33121</b> <small>NEW</small>
IN/EX [4]	11,05 x 6 x 36,0	B1			058 103 415	<b>81-33111</b>
IN/EX [4]	11,15 x 6 x 36,0	B1				<b>81-33118</b> <small>NEW</small>
EX [4]	11,04 x 6 x 39,0	G2				<b>81-33122</b> <small>NEW</small>
[8]	H 12 x 34,5				022 109 423 A 022 109 423 D	<b>50 006 419</b>
[4]					022 109 417 C 022 109 417 E	<b>50 006 144</b>

## 371

**84,5**
**CGEA Euro 5**

04.2010 → 03.2018

**B**

(LA)

**6**

 2995 cm<sup>3</sup> 4V

245 kW

(333 PS)

13,3:1 89,00 mm

Fortsetzung nächste Seite / continued on next page / suite page suivante / continuación página próxima / Продолжение на следующей странице

					Reference	Item No.	
	IN [2]	33,8 x 6 x 104,0	S - -	- 45° - -	22 - III	06K 109 601 06L 109 601	<b>331162</b> <small>NEW</small>
	IN [2]	33,9 x 6 x 104,0	S - -	- 45° - -	22 - III	06D 109 601K 06E 109 601E 06E 109 601F	<b>331116</b>
	EX [2]	28,0 x 5,9 x 101,8	RA/S- Cr - Na	- 45° - VS -	22 - III	06E 109 611K 06K 109 611A 06K 109 611E 079 109 611D 079 109 611F 079 109 611G	<b>331160</b> <small>NEW</small>
	[50]	Ø 6 mm				036 109 651A	<b>MK-6H</b>
	[4]					06E109417AA 06E109417N	<b>50 007 657</b>

## 372 84,5

CGFA Euro 5		04.2010 → 03.2018	B (LA) 6	2995 cm <sup>3</sup> 4V	245-283 kW	(333-385 PS)	13,3:1	89,00 mm
	IN [2]	33,8 x 6 x 104,0	S - -	- 45° - -	22 - III	06K 109 601 06L 109 601		<b>331162</b> <small>NEW</small>
	IN [2]	33,9 x 6 x 104,0	S - -	- 45° - -	22 - III	06D 109 601K 06E 109 601E 06E 109 601F		<b>331116</b>
	EX [2]	28,0 x 5,9 x 101,8	RA/S- Cr - Na	- 45° - VS -	22 - III	06E 109 611K 06K 109 611A 06K 109 611E 079 109 611D 079 109 611F 079 109 611G		<b>331160</b> <small>NEW</small>
	[50]	Ø 6 mm				036 109 651A		<b>MK-6H</b>

## 373 84,5

CJTA Euro 5		08.2010 → 03.2018	B (K) 6	2995 cm <sup>3</sup> 4V	213 kW	(290 PS)	10,5	89,00 mm
	IN [2]	33,8 x 6 x 104,0	S - -	- 45° - -	22 - III	06K 109 601 06L 109 601		<b>331162</b> <small>NEW</small>
	IN [2]	33,9 x 6 x 104,0	S - -	- 45° - -	22 - III	06D 109 601K 06E 109 601E 06E 109 601F		<b>331116</b>
	EX [2]	28,0 x 5,9 x 101,8	RA/S- Cr - Na	- 45° - VS -	22 - III	06E 109 611K 06K 109 611A 06K 109 611E 079 109 611D 079 109 611F 079 109 611G		<b>331160</b> <small>NEW</small>
	[50]	Ø 6 mm				036 109 651A		<b>MK-6H</b>
	IN/EX [4]	11,04 x 6 x 39,0	B1					<b>81-33121</b> <small>NEW</small>
	IN/EX [4]	11,05 x 6 x 36,0	B1			058 103 415		<b>81-33111</b>
	IN/EX [4]	11,15 x 6 x 36,0	B1					<b>81-33118</b> <small>NEW</small>
	EX [4]	11,04 x 6 x 39,0	G2					<b>81-33122</b> <small>NEW</small>

## 374 84,5

CGNA		01.2011 → 03.2018	B (NA) 8	4163 cm <sup>3</sup> 4V	265 kW	(360 PS)	92,80 mm
------	--	-------------------	----------	-------------------------	--------	----------	----------

Fortsetzung nächste Seite / continued on next page / suite page suivante / continuación página próxima / Продолжение на следующей странице

					Reference	Item No.
IN [2]	33,9 x 6 x 104,0	S - -	- 45° - -	22 - III	06D 109 601K 06E 109 601E 06E 109 601F	<b>331116</b>
EX [2]	28,0 x 6 x 101,9	RA/S- Cr - Na	- 45° - VS -	22 - III	06D 109 611 P 06D 109 611H 06J 109 611D	<b>331126</b>
[50]	Ø 6 mm				036 109 651A	<b>MK-6H</b>
IN/EX [4]	11,04 x 6 x 39,0	B1			058 103 415	<b>81-33121</b>
IN/EX [4]	11,05 x 6 x 36,0	B1				<b>81-33111</b>
IN/EX [4]	11,15 x 6 x 36,0	B1				<b>81-33118</b>
EX [4]	11,04 x 6 x 39,0	G2				<b>81-33122</b>

## 375

**84,5**

**CYJA** 01.2015 → 03.2018 B (K) 6 2995 cm<sup>3</sup> 4V 235 kW (320 PS) 10,5 89,00 mm

IN [2]	33,9 x 6 x 104,0	S - -	- 45° - -	22 - III	06D 109 601K 06E 109 601E 06E 109 601F	<b>331116</b>
EX [2]	28,0 x 5,9 x 101,8	RA/S- Cr - Na	- 45° - VS -	22 - III	06E 109 611K 06K 109 611A 06K 109 611E 079 109 611D 079 109 611F 079 109 611G	<b>331160</b>
[50]	Ø 6 mm				036 109 651A	<b>MK-6H</b>

## 376

**85,5**

**311 (1.6L)** B 4 1584 cm<sup>3</sup> 2V 40 kW (54 PS) 7,5:1 69,00 mm  
**B** 08.1964 → 07.1979 B (NA) 4 1584 cm<sup>3</sup> 2V 35 kW (48 PS) 7,5:1 69,00 mm  
**T** 08.1965 → 07.1973 B (NA) 4 1584 cm<sup>3</sup> 2V 40 kW (54 PS) 7,5:1 69,00 mm

91 322 7..

IN [2]	35,5 x 8 x 111,7	S - -	- 45° - -	22 - III	311 109 601	<b>33009</b>
EX [2]	32,0 x 8 x 111,9	A/S - -	- 45° - VS -	22 - III	311 109 612 A	<b>33008</b>
[50]	Ø 8 mm				113 109 651 A 400 501 068	<b>MK-8H</b>
IN [4]	12,04 x 8 x 64,5	B1			113 101 401	<b>81-3907</b>
IN [4]	12,07 x 8 x 64,5	B1				<b>81-3915</b>
IN [4]	12,24 x 8 x 64,5	B1			113 101 404	<b>81-3908</b>
EX [4]	12,04 x 8 x 65,5	B1			113 101 415	<b>81-3910</b>
EX [4]	12,07 x 8 x 65,5	B1				<b>81-3916</b>

## 377

**85,5**

**AF** 08.1967 → 10.1992 B (NA) 4 1584 cm<sup>3</sup> 2V 33-37 kW (46-50 PS) 69,00 mm

91 320 7..

IN [2]	35,5 x 8 x 111,7	S - -	- 45° - -	22 - III	311 109 601	<b>33009</b>
EX [2]	30,0 x 9 x 111,9	A/S - Cr -	- 45° - VS -	22 - III	043 109 611	<b>33016</b>
EX [2]	32,0 x 8 x 111,9	A/S - -	- 45° - VS -	22 - III	311 109 612 A	<b>33008</b>
[50]	Ø 8 mm				113 109 651 A 400 501 068	<b>MK-8H</b>
[50]	Ø 9 mm					<b>MK-9H</b>

## 378

**85,5**

**AD** 08.1968 → 12.1982 B (NA) 4 1584 cm<sup>3</sup> 2V 35-48 kW (48-50 PS) 7,5 69,00 mm

IN [2]	35,5 x 8 x 111,7	S - -	- 45° - -	22 - III	311 109 601	<b>33009</b>
EX [2]	32,0 x 8 x 111,9	A/S - -	- 45° - VS -	22 - III	311 109 612 A	<b>33008</b>

Fortsetzung nächste Seite / continued on next page / suite page suivante / continuación página próxima / Продолжение на следующей странице



					Reference	Item No.
[50]	Ø 8 mm				113 109 651 A 400 501 068	<b>MK-8H</b>
IN [4]	12,04 x 8 x 64,5	B1			113 101 401	<b>81-3907</b>
IN [4]	12,07 x 8 x 64,5	B1				<b>81-3915</b>
IN [4]	12,10 x 8 x 64,0	B1			113 101 403 A	<b>81-3958</b>
IN [4]	12,24 x 8 x 64,5	B1			113 101 404	<b>81-3908</b>
EX [4]	12,04 x 8 x 65,5	B1			113 101 415	<b>81-3910</b>
EX [4]	12,07 x 8 x 65,5	B1				<b>81-3916</b>
EX [4]	14,10 x 9 x 64,0	G1			043 101 417 C	<b>81-3956</b>
<b>379</b>	<b>85,5</b>					
<b>AS</b>	08.1970 → 12.1979	B (NA)	4	1584 cm <sup>3</sup> 2V	37 kW (50 PS)	7,5 69,00 mm
IN [2]	35,5 x 8 x 111,7	S - -	- 45° -	- 22 - III	311 109 601	<b>33009</b>
[50]	Ø 8 mm				113 109 651 A 400 501 068	<b>MK-8H</b>
IN [4]	12,10 x 8 x 64,0	B1			113 101 403 A	<b>81-3958</b>
EX [4]	14,10 x 9 x 64,0	G1			043 101 417 C	<b>81-3956</b>
<b>380</b>	<b>85,5</b>					
<b>AJ</b>	08.1970 → 12.1980	B (NA)	4	1584 cm <sup>3</sup> 2V	36-37 kW (48-50 PS)	7,5:1 69,00 mm
IN [2]	35,5 x 8 x 111,7	S - -	- 45° -	- 22 - III	311 109 601	<b>33009</b>
EX [2]	30,0 x 9 x 111,9	A/S - Cr -	- 45° - VS -	- 22 - III	043 109 611	<b>33016</b>
[50]	Ø 8 mm				113 109 651 A 400 501 068	<b>MK-8H</b>
[50]	Ø 9 mm					<b>MK-9H</b>
IN [4]	12,10 x 8 x 64,0	B1			113 101 403 A	<b>81-3958</b>
EX [4]	14,10 x 9 x 64,0	G1			043 101 417 C	<b>81-3956</b>
<b>381</b>	<b>85,5</b>					
<b>CZ</b>		B	4	1584 cm <sup>3</sup> 2V	34 kW (46 PS)	7,5:1 69,00 mm
[8]	H 24 x 52,5				022 109 309	<b>50 007 625</b>
<b>382</b>	<b>85,5</b>					
<b>CT</b>	05.1979 → 12.2005	AB (NA)	4	1584 cm <sup>3</sup> 2V	37-50 kW (50-67 PS)	7,5 69,00 mm
[8]	H 24 x 52,5				022 109 309	<b>50 007 625</b>
<b>383</b>	<b>86</b>					
<b>AXZ</b>	11.2005 → 11.2010	B (NA)	6	3168 cm <sup>3</sup> 4V	184 kW (250 PS)	12 90,90 mm
IN [2]	33,2 x 6 x 102,4	S - -	- 45° -	- 22 - III	022 109 601 AJ 022 109 601 G	<b>331127</b>
IN [2]	33,2 x 6 x 136,3	S - -	- 45° -	- 22 - III	022 109 601 AK 022 109 601 H	<b>331128</b>
EX [2]	30,2 x 6 x 102,2	RA/S- -	- 45° - VS -	- 22 - III	022 109 611 AA 022 109 611 N 03H 109 611 D	<b>331129</b>
EX [2]	30,2 x 6 x 136,1	RA/S- -	- 45° - VS -	- 22 - III	022 109 611 AB 022 109 611 M 022 109 611 P 03H 109 611 E	<b>331130</b>
[50]	Ø 6 mm				036 109 651A	<b>MK-6H</b>

Fortsetzung nächste Seite / continued on next page / suite page suivante / continuación página próxima / Продолжение на следующей странице

					Reference	Item No.
IN [4] EX [4]	10,06 x 6 x 44,0 10,06 x 6 x 65,0	B1 B1				<b>81-33119</b> <small>NEW</small> <b>81-33120</b> <small>NEW</small>
[8]	H 12 x 34,5				022 109 423 B 022 109 423 C	<b>50 006 491</b>
[4]					022 109 417 C 022 109 417 E	<b>50 006 144</b>

## 384 86,5

<b>CH</b>	04.1975 → 09.1983	B (NA)	4	1984 cm <sup>3</sup>	2V	55 kW	(75 PS)	8	84,40 mm
IN [4] EX [4]	14,00 x 9 x 56,5 14,00 x 9 x 61,0	B1 B1							048 103 415 A 046 103 415 A
									<b>81-3316</b> <b>81-3303</b>

## 385 89

<b>BHK</b>	10.2005 → 05.2010	B (NA)	6	3597 cm <sup>3</sup>	4V	206 kW	(280 PS)	12	96,40 mm
<b>BLV</b>	06.2005 → 12.2016	B (NA)	6	3580 cm <sup>3</sup>	4V	206 kW	(280 PS)	12	95,90 mm
<b>BWS</b>	04.2007 → 12.2016	B (NA)	6	3597 cm <sup>3</sup>	4V	220 kW	(300 PS)	11,4	96,40 mm

IN [2]	33,2 x 6 x 102,4	S - -	- 45° - -	22 - III	022 109 601 AJ 022 109 601G	<b>331127</b>
IN [2]	33,2 x 6 x 136,3	S - -	- 45° - -	22 - III	022 109 601 AK 022 109 601H	<b>331128</b>
EX [2]	30,2 x 6 x 102,2	RA/S- -	- 45° - VS -	22 - III	022 109 611 AA 022 109 611N 03H 109 611D	<b>331129</b>
EX [2]	30,2 x 6 x 136,1	RA/S- -	- 45° - VS -	22 - III	022 109 611 AB 022 109 611M 022 109 611P 03H 109 611E	<b>331130</b>
[50]	∅ 6 mm				036 109 651A	<b>MK-6H</b>
IN [4] EX [4]	10,06 x 6 x 44,0 10,06 x 6 x 65,0	B1 B1				<b>81-33119</b> <small>NEW</small> <b>81-33120</b> <small>NEW</small>
[8]	H 12 x 34,5				022 109 423 B 022 109 423 C	<b>50 006 491</b>
[4]					022 109 417 C 022 109 417 E	<b>50 006 144</b>

V

## 386 89

<b>CNNA</b>	06.2008 → 12.2016	B (NA)	6	3580 cm <sup>3</sup>	4V	206 kW	(280 PS)	11,4	95,90 mm
IN [4] EX [4]	10,06 x 6 x 44,0 10,06 x 6 x 65,0	B1 B1							<b>81-33119</b> <small>NEW</small> <b>81-33120</b> <small>NEW</small>

## 387 89

<b>CGRA Euro 5</b>	04.2010 → 03.2018	B (NA)	6	3597 cm <sup>3</sup>	4V	206 kW	(280 PS)	11,4	96,40 mm
<b>CHNA</b>	11.2008 → 03.2016	B (NA)	6	3597 cm <sup>3</sup>	4V	206 kW	(280 PS)	12	96,35 mm
<b>CMTA Euro 5</b>	08.2010 → 03.2018	B (NA)	6	3597 cm <sup>3</sup>	4V	183 kW	(249 PS)	11,4	96,40 mm
<b>CMVA</b>	11.2008 → 03.2016	B (NA)	6	3597 cm <sup>3</sup>	4V	206 kW	(280 PS)	11,4	96,40 mm

Fortsetzung nächste Seite / continued on next page / suite page suivante / continuación página próxima / Продолжение на следующей странице

					Reference	Item No.
IN [2]	33,2 x 6 x 102,4	S - -	- 45° - -	22 - III	022 109 601 AJ 022 109 601G	<b>331127</b>
IN [2]	33,2 x 6 x 136,3	S - -	- 45° - -	22 - III	022 109 601 AK 022 109 601H	<b>331128</b>
EX [2]	30,2 x 6 x 102,2	RA/S- -	- 45° - VS -	22 - III	022 109 611 AA 022 109 611N 03H 109 611D	<b>331129</b>
EX [2]	30,2 x 6 x 136,1	RA/S- -	- 45° - VS -	22 - III	022 109 611 AB 022 109 611M 022 109 611P 03H 109 611E	<b>331130</b>
[50]	Ø 6 mm				036 109 651A	<b>MK-6H</b>
IN [4]	10,06 x 6 x 44,0	B1				<b>81-33119</b>
EX [4]	10,06 x 6 x 65,0	B1				<b>81-33120</b>

**388**
**89**
**CDVA Euro 5** 05.2009 → 11.2010 B (NA) 6 3597 cm<sup>3</sup> 4V 191 kW (260 PS) 11,4 96,40 mm

IN [2]	33,2 x 6 x 102,4	S - -	- 45° - -	22 - III	022 109 601 AJ 022 109 601G	<b>331127</b>
IN [2]	33,2 x 6 x 136,3	S - -	- 45° - -	22 - III	022 109 601 AK 022 109 601H	<b>331128</b>
EX [2]	30,2 x 6 x 102,2	RA/S- -	- 45° - VS -	22 - III	022 109 611 AA 022 109 611N 03H 109 611D	<b>331129</b>
EX [2]	30,2 x 6 x 136,1	RA/S- -	- 45° - VS -	22 - III	022 109 611 AB 022 109 611M 022 109 611P 03H 109 611E	<b>331130</b>
[50]	Ø 6 mm				036 109 651A	<b>MK-6H</b>
IN [4]	10,06 x 6 x 44,0	B1				<b>81-33119</b>
EX [4]	10,06 x 6 x 65,0	B1				<b>81-33120</b>
[4]					022 109 417 C 022 109 417 E	<b>50 006 144</b>

**389**
**90**
**CA** 08.1971 → 07.1973 B (NA) 4 1679 cm<sup>3</sup> 2V 49 kW (66 PS) 7,3 66,00 mm  
**CB** 08.1971 → 12.1973 B (NA) 4 1679 cm<sup>3</sup> 2V 49 kW (67 PS) 7,3 66,00 mm  
**W** 01.1969 → 12.1973 B (NA) 4 1679 cm<sup>3</sup> 2V 59-63 kW (80-86 PS) 8,2 66,00 mm

IN [2]	39,5 x 8 x 117,0	S - -	- 30° - -	22 - III	021 109 601	<b>33014</b>
EX [2]	33,0 x 8,9 x 117,2	A/S - Cr -	- 45° - VS -	22 - III	022 109 612 D	<b>33012</b>
[50]	Ø 8 mm				113 109 651 A 400 501 068	<b>MK-8H</b>
[50]	Ø 9 mm					<b>MK-9H</b>
IN [4]	12,04 x 8 x 61,0	B1			021 101 402	<b>81-3940</b>
IN [4]	12,07 x 8 x 61,0	B1			021 101 403 A	<b>81-3941</b>
IN [4]	12,24 x 8 x 61,0	B1				<b>81-3942</b>
EX [4]	13,04 x 9 x 66,5	B1			021 101 416 021 101 417 A	<b>81-3946</b>
EX [4]	13,07 x 9 x 66,5	B1			021 101 417 A	<b>81-3947</b>
EX [4]	13,24 x 9 x 66,5	B1				<b>81-3948</b>

**390**
**90,9**
**AGL** 05.1996 → 07.2006 B (NA) 4 2295 cm<sup>3</sup> 4V 105 kW (143 PS) 8,8 88,40 mm

Fortsetzung nächste Seite / continued on next page / suite page suivante / continuación página próxima / Продолжение на следующей странице

					Reference	Item No.
IN [2] EX [2]	35,0 x 7 x 101,5 31,0 x 7 x 103,5	S - Ni - RA - Ni -	- 45° - - - 45° - -	9 - 9 -	00A 109 601A	<b>26048</b> <b>260490</b>
[50]	∅ 7 mm				027 109 651	<b>RK-7H</b>
[8]	H 35 x 24 x 24				00A 109 309	<b>50 006 421</b>

## 391

92

2L 04.1989 → 03.1997 D (NA) 4 2446 cm<sup>3</sup> 2V 58-61 kW (79-83 PS) 22 92,00 mm  
94 756 6..

IN/EX [6]	13,05 x 8.02 x 40,0	G1				<b>81-71002</b>
-----------	---------------------	----	--	--	--	-----------------

## 392

93

AN 07.1973 → 03.1975 B (NA) 4 1795 cm<sup>3</sup> 2V 63 kW (86 PS) 7,8:1 66,00 mm  
AP 11.1973 → 07.1975 B (NA) 4 1795 cm<sup>3</sup> 2V 50 kW (68 PS) 7,3 66,00 mm  
AT 07.1973 → 03.1975 B (NA) 4 1795 cm<sup>3</sup> 2V 55 kW (75 PS) 7,5 66,00 mm

IN [2] EX [2]	39,5 x 8 x 117,0 33,0 x 8,9 x 117,2	S - - A/S - Cr -	- 30° - - - 45° - VS -	22 - III 22 - III	021 109 601 022 109 612 D	<b>33014</b> <b>33012</b>
[50]	∅ 8 mm				113 109 651 A 400 501 068	<b>MK-8H</b>
[50]	∅ 9 mm					<b>MK-9H</b>
IN [4] IN [4] IN [4] EX [4]	12,04 x 8 x 61,0 12,07 x 8 x 61,0 12,24 x 8 x 61,0 13,04 x 9 x 66,5	B1 B1 B1 B1			021 101 402 021 101 403 A 021 101 416 021 101 417 A	<b>81-3940</b> <b>81-3941</b> <b>81-3942</b> <b>81-3946</b>
EX [4] EX [4]	13,07 x 9 x 66,5 13,24 x 9 x 66,5	B1 B1			021 101 417 A	<b>81-3947</b> <b>81-3948</b>

## 393

93

AGK 07.1997 → 05.2003 D (A) 4 2799 cm<sup>3</sup> 3V 92 kW (125 PS) 20 103,00 mm  
ATA 01.1999 → 07.2006 D (A) 4 2799 cm<sup>3</sup> 3V 96 kW (130 PS) 17,8 103,00 mm  
AUH 05.2001 → 07.2006 D (A) 4 2799 cm<sup>3</sup> 3V 116 kW (158 PS) 17,8:1 103,00 mm  
BCQ 05.2001 → 07.2006 D (LA) 4 2799 cm<sup>3</sup> 3V 116 kW (158 PS) 17,8 103,00 mm  
40 307 6.., 97 412 7..

IN [2] EX [2]	33,0 x 7 x 105,1 39,7 x 7 x 105,1	S - Cr - RA/S - Cr -	- 30° - - - 45° - VS -	22 - III 22 - III	062 109 601 062 109 611A	<b>331113</b> <b>331112</b>
IN/EX [4]	12,08/15 x 7 x 36,5	B1			037 103 415 037 103 419 B	<b>81-33103</b>
IN/EX [4]	12,25/15 x 7 x 36,5	B1				<b>81-33104</b>

## 394

94

CJ 08.1975 → 07.1979 B (NA) 4 1970 cm<sup>3</sup> 2V 51 kW (70 PS) 7,3 71,00 mm  
CU 05.1979 → 04.1986 B (NA) 4 1970 cm<sup>3</sup> 2V 51 kW (70 PS) 7,3 71,00 mm  
GD 08.1975 → 06.1977 B (NA) 4 1970 cm<sup>3</sup> 2V 51 kW (70 PS) 7,3:1 71,00 mm  
GE 08.1976 → 06.1979 B (NA) 4 1970 cm<sup>3</sup> 2V 51 kW (70 PS) 7,3 71,00 mm  
92 803 6..

IN [2] EX [2]	39,5 x 8 x 117,0 33,0 x 8,9 x 117,2	S - - A/S - Cr -	- 30° - - - 45° - VS -	22 - III 22 - III	021 109 601 022 109 612 D	<b>33014</b> <b>33012</b>
[50]	∅ 8 mm				113 109 651 A 400 501 068	<b>MK-8H</b>
[50]	∅ 9 mm					<b>MK-9H</b>

Fortsetzung nächste Seite / continued on next page / suite page suivante / continuación página próxima / Продолжение на следующей странице

					Reference	Item No.
	IN [4] IN [4] IN [4] EX [4]	12,04 x 8 x 61,0 12,07 x 8 x 61,0 12,24 x 8 x 61,0 13,04 x 9 x 66,5	B1 B1 B1 B1		021 101 402 021 101 403 A  021 101 416 021 101 417 A 021 101 417 A	<b>81-3940</b> <b>81-3941</b> <b>81-3942</b> <b>81-3946</b> <b>81-3947</b> <b>81-3948</b>

**395**

**94**

**CV** 05.1979 → 12.1982 B (NA) 4 1970 cm<sup>3</sup> 2V 51 kW (70 PS) 7,3 71,00 mm  
92 803 6..

	IN [2] EX [2]	39,5 x 8 x 117,0 33,0 x 8,9 x 117,2	S - - A/S - Cr -	- 30° - - - 45° - VS -	22 - III 22 - III	021 109 601 022 109 612 D	<b>33014</b> <b>33012</b>
	[50] [50]	∅ 8 mm ∅ 9 mm				113 109 651 A 400 501 068	<b>MK-8H</b> <b>MK-9H</b>
	IN [4] IN [4] IN [4] EX [4]  EX [4] EX [4]	12,04 x 8 x 61,0 12,07 x 8 x 61,0 12,24 x 8 x 61,0 13,04 x 9 x 66,5  13,07 x 9 x 66,5 13,24 x 9 x 66,5	B1 B1 B1 B1  B1 B1			021 101 402 021 101 403 A  021 101 416 021 101 417 A 021 101 417 A	<b>81-3940</b> <b>81-3941</b> <b>81-3942</b> <b>81-3946</b> <b>81-3947</b> <b>81-3948</b>
	[8]	H 24 x 52,5				022 109 309	<b>50 007 625</b>

**396**

**94**

**DF** 08.1982 → 07.1992 B (NA) 4 1913 cm<sup>3</sup> 2V 44 kW (60 PS) 8,4 68,90 mm

	[50] [50]	∅ 8 mm ∅ 9 mm				113 109 651 A 400 501 068	<b>MK-8H</b> <b>MK-9H</b>
	IN [4] IN [4] IN [4] EX [4]  EX [4] EX [4]	12,04 x 8 x 61,0 12,07 x 8 x 61,0 12,24 x 8 x 61,0 13,04 x 9 x 66,5  13,07 x 9 x 66,5 13,24 x 9 x 66,5	B1 B1 B1 B1  B1 B1			021 101 402 021 101 403 A  021 101 416 021 101 417 A 021 101 417 A	<b>81-3940</b> <b>81-3941</b> <b>81-3942</b> <b>81-3946</b> <b>81-3947</b> <b>81-3948</b>
	[8]	H 24 x 52,5				022 109 309	<b>50 007 625</b>

**397**

**94**

**DG** 08.1982 → 07.1992 B (NA) 4 1913 cm<sup>3</sup> 2V 57 kW (78 PS) 8,4 68,90 mm  
**DH** 01.1983 → 02.1989 B (NA) 4 1913 cm<sup>3</sup> 2V 60-62 kW (82-84 PS) 8,4 69,00 mm  
**GW** 08.1983 → 02.1989 B (NA) 4 1913 cm<sup>3</sup> 2V 66 kW (90 PS) 8,6 69,00 mm

	IN [2] EX [2]	40,0 x 8 x 122,4 34,0 x 8,9 x 122,6	S - - A/S - Cr -	- 45° - - - 45° - VS -	22 - III 22 - III	025 109 601 025 109 601C 025 109 612 A	<b>39112</b> <b>3911</b>
	[50] [50]	∅ 8 mm ∅ 9 mm				113 109 651 A 400 501 068	<b>MK-8H</b> <b>MK-9H</b>

Fortsetzung nächste Seite / continued on next page / suite page suivante / continuación página próxima / Продолжение на следующей странице

					Reference	Item No.
	IN [4] IN [4] IN [4] EX [4]	12,04 x 8 x 61,0 12,07 x 8 x 61,0 12,24 x 8 x 61,0 13,04 x 9 x 66,5	B1 B1 B1 B1		021 101 402 021 101 403 A  021 101 416 021 101 417 A 021 101 417 A	<b>81-3940</b> <b>81-3941</b> <b>81-3942</b> <b>81-3946</b> <b>81-3947</b> <b>81-3948</b>
	EX [4] EX [4]	13,07 x 9 x 66,5 13,24 x 9 x 66,5	B1 B1			
	[8]	H 24 x 52,5			022 109 309	<b>50 007 625</b>

## 398

94

DJ	08.1984 → 07.1992	B (NA)	4	2109 cm <sup>3</sup>	2V	82 kW	(112 PS)	10,5	76,00 mm
MV	08.1985 → 07.1992	B (NA)	4	2109 cm <sup>3</sup>	2V	67-71 kW	(91-97 PS)	8,7	76,00 mm
SR	10.1986 → 07.1992	B (NA)	4	2109 cm <sup>3</sup>	2V	64 kW	(87 PS)	8,7	76,00 mm
SS	07.1989 → 07.1992	B (NA)	4	2109 cm <sup>3</sup>	2V	68-70 kW	(92-95 PS)	8,7	76,00 mm

90 129 7..

	IN [2]	40,0 x 8 x 122,4	S - -	- 45° - -	22 - III	025 109 601 025 109 601C	<b>39112</b>
	EX [2]	34,0 x 8,9 x 122,6	A/S - Cr -	- 45° - VS -	22 - III	025 109 612 A	<b>3911</b>
	[50]	Ø 8 mm				113 109 651 A 400 501 068	<b>MK-8H</b>
	[50]	Ø 9 mm					<b>MK-9H</b>
	IN [4] IN [4] IN [4] EX [4]	12,04 x 8 x 61,0 12,07 x 8 x 61,0 12,24 x 8 x 61,0 13,04 x 9 x 66,5	B1 B1 B1 B1			021 101 402 021 101 403 A  021 101 416 021 101 417 A 021 101 417 A	<b>81-3940</b> <b>81-3941</b> <b>81-3942</b> <b>81-3946</b> <b>81-3947</b> <b>81-3948</b>
	EX [4] EX [4]	13,07 x 9 x 66,5 13,24 x 9 x 66,5	B1 B1				
	[8]	H 24 x 52,5				022 109 309	<b>50 007 625</b>
		- - G - S -	- SB - -			025 101 065 C 025 101 355 C	<b>50 003 097</b> (1)
					25 Nm 50 Nm		
		- V - G - S -	- SB - -		ready-to-install	025 101 065 C 025 101 355 C	<b>50 003 397</b> (1)

(1) Ansaugkanal/inlet port/canal d'admission/colector de admisión/Впускной канал 40 mm x 30 mm

## 399

94

SP	08.1987 → 07.1989	B (NA)	4	1913 cm <sup>3</sup>	2V	54-68 kW	(73-92 PS)	8,7:1	68,90 mm
	[8]	H 24 x 52,5				022 109 309	<b>50 007 625</b>		

## 400

94

ISF2.8	01.2018 →	D (LA)	4	2776 cm <sup>3</sup>	4V	80-120 kW	(109-163 PS)	16,9:1	100,00 mm
--------	-----------	--------	---	----------------------	----	-----------	--------------	--------	-----------









41 715 6..

	[1]	M 30 x 60 x 16					<b>20 1012 B6060</b>
--	-----	----------------	--	--	--	--	----------------------

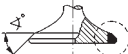

					Reference	Item No.
<b>401</b>		<b>98,43</b>				
<b>4.236</b>		01.1982 → 10.1986	D (NA)	4	3866 cm <sup>3</sup> 2V	55-65 kW (75-88 PS) 16:1 127,00 mm
91 118 6..						
	IN [2]	44,2 x 9,5 x 122,8	S - -	- 45° -	1 - III	<b>105-03365</b>
	IN [2]	44,2 x 9,5 x 122,8 M + 1	S - -	- 45° -	1 - III	<b>105-35472</b>
	EX [2]	36,5 x 9,5 x 123,2	A/S - -	- 45° -	1 - III	<b>105-03366</b>
	EX [2]	36,6 x 9,5 x 123,3 M + 1	A/S - -	- 45° -	1 - III	<b>105-35473</b>
	IN [6]	15,90 x 9.515 x 57,9	G2			<b>81-85003</b>
	EX [6]	15,90 x 9.53 x 61,1	G2			<b>81-85004</b>
<b>402</b>		<b>102</b>				
<b>6 BTAA Euro 2</b>		05.1998 →	D (LA)	6	5883 cm <sup>3</sup> 2V	94-173 kW (124-235 PS) 17-17,6 120,00 mm
40 322 6.., 40 324 6.., 99 676 6..						
	IN [2]	45,0 x 8 x 129,2	S - Cr -	- 30° -	18 - III	<b>105-35615</b>
	EX [2]	42,0 x 8 x 129,0	A/S - Cr -	- 45° -	1 - III	<b>105-35616</b>
<b>403</b>		<b>102</b>				
<b>ISB-250 Euro 1</b>		07.2005 → 12.2014	D (LA)	6	5883 cm <sup>3</sup> 4V	184-186 kW (250-253 PS) 120,00 mm
40 588 6..						
	IN [2]	33,0 x 7 x 124,7	S - Cr -	- 30° -	9 - III	<b>105-35632</b>
	EX [2]	33,0 x 7 x 124,3	A/S - Cr -	- 45° -	9 - III	<b>105-35633</b>
	[50]	Ø 7 mm			027 109 651	<b>RK-7H</b>
	IN [2]	34,91 x 29.6 x 5,8	G1 20°			<b>92-17000</b>
	EX [2]	34,91 x 29.5 x 5,8	G1 20°			<b>92-17001</b>
<b>404</b>		<b>108</b>				
<b>D 0834 LFL 63 Euro 5</b>		07.2005 →	D (LA)	4	4580 cm <sup>3</sup> 4V	110 kW (150 PS) 125,00 mm
<b>D 0834 LFL 64 Euro 5</b>		01.2014 →	D (LA)	4	4580 cm <sup>3</sup> 4V	132-137 kW (180-186 PS) 125,00 mm
<b>D 0834 LFL 65 Euro 5</b>		01.2014 →	D (LA)	4	4580 cm <sup>3</sup> 4V	162-166 kW (220-226 PS) 125,00 mm
<b>D 0836 LFL 64 Euro 5</b>		07.2005 →	D (LA)	6	6871 cm <sup>3</sup> 4V	202-213 kW (275-290 PS) 125,00 mm
<b>D 0836 LOH 64 Euro 5</b>		01.2014 →	D (LA)	6	6871 cm <sup>3</sup> 4V	209-213 kW (284-290 PS) 125,00 mm
40 217 6.., 40 871 6.., 40 910 6.., 41 255 6..						
	IN [2]	38,0 x 7 x 141,5	S - Cr -	- 30° -	22 - III	<b>25304</b>
	EX [2]	34,0 x 7 x 141,2	A/S - Cr -	- 45° -	22 - III	<b>25305</b>
	[50]	Ø 7 mm			021 109 651	<b>MK-7H</b>
	IN/EX [6]	13,03 x 7.02 x 60,0	G2			<b>81-25109</b>
	IN/EX [1]	13,03 x 7.02 x 60,0	G2			<b>81-25116</b> <small>NEW</small> (1)
	(1)	zusätzlicher Einstich auf dem Durchmesser der Ventilschaftabdichtungen additional groove on the diameter of the valve stem seals Entaille supplémentaire au niveau du diamètre des joints de queue de soupape Escotadura adicional en el diámetro de los retenes de válvula дополнительная канавка по диаметру уплотнений стержня клапана				
	[12]	M 32 x 69,3 x 20				<b>20 0102 08260</b>
<b>405</b>		<b>114</b>				
<b>6 CT 8.3 Euro 2</b>		02.1988 →	D (A)	6	8270 cm <sup>3</sup> 2V	154-160 kW (209-218 PS) 17,3:1 135,00 mm
Fortsetzung nächste Seite / continued on next page / suite page suivante / continuación página próxima / Продолжение на следующей странице						

V

					Reference	Item No.
 IN [2] EX [2]	52,0 x 9,5 x 151,0 46,0 x 9,5 x 150,9	S - Cr - A/S - Cr -	- 30° - - - 45° - -	18 - III 1 - III		105-35617 105-35618
 [1]	M					20 1012 20000
<b>406</b>  <b>114</b> <b>6 CTA 8.3</b> 01.1991 →    D (LA) 6    8268 cm <sup>3</sup> 2V    213-235 kW (290-320 PS) 17,5:1    135,00 mm						
 [1]	M					20 1012 20000

V

		Cyl.		mm	cm <sup>3</sup>		Comp. Ratio $\epsilon$	kW	PS	Pos
4.236		D (NA) 4		98,43 x 127	3866	2	16:1	55-65	75-88	67
AD 31	A, B, D-A, L-A, P-A	D (LA) 4		92 x 90	2390	2	17,5:1	96-110	130-150	58
AD 41	B, D, L-A, P-A	D (LA) 6		92 x 90	3590	2	17,5:1	113-147	153-200	58
AQAD 30	A	D 4		92 x 90	2390	2	17,5:1	81	110	58
AQAD 31	A	D 4		92 x 90	2390	2	16:1	96	130	58
AQAD 40	A, B	D (LA) 6		92 x 90		2	21:1	81-121	110-165	58
B 10	E	B (NA) 4		70 x 72	1108	2	8,5:1	33-35	45-48	1
B 13		B (NA) 4		73 x 76,5	1289	2	8,5:1	49	66	2
B 130		B (NA) 4		73 x 76,5	1289	2	9,6	42	57	2
B 14	OE	B (NA) 4		76 x 77	1397	2	9,3:1	51	69	5
B 14.3	E	B (NA) 4		76 x 77	1397	2	9,2	46-53	63-72	5
B 14.4	S	B (NA) 4		76 x 77	1397	2	9,25	50-53	68-72	5
B 17	A	B 4		84,14 x 80	1784	2		66	90	44
B 18	EP, F	B (NA) 4		81 x 83,5	1721	2		70-80	95-109	15
B 18	E	B (NA) 4		81 x 83,5	1721	2	9,5	78-80	106-109	14
B 18	FT	B (A) 4		81 x 83,5	1721	2	8	88-90	120-122	15
B 18	U	B (NA) 4		82,7 x 83,5	1794	2	9,7	66	90	30
B 19	A, E	B (NA) 4		88,9 x 80	1986	2		60-86	82-117	51
B 19	K	B (NA) 4		88,9 x 80	1986	2	9,2	71-74	97-101	51
B 19	ET	B (A) 4		88,9 x 80	1986	2	9,3:1	100-110	136-150	51
B 20	F 208	B 4		82,7 x 93	1998	2	9,5:1	80	109	31
B 20	F	B (NA) 4		82,7 x 93	1998	2	9,5	80-88	108-120	29
B 20	A, B, E	B (NA) 4		88,9 x 80	1986	2		60-103	82-140	50
B 200	E, EA, K, KE	B (NA) 4		88,9 x 80	1986	2		70-89	95-121	51
B 200	F	B (NA) 4		88,9 x 80	1986	2	10:1	80-82	109-112	51
B 200	G	B (NA) 4		88,9 x 80	1986	2	10:1	80-89	109-121	52
B 200	FT	B (A) 4		88,9 x 80	1986	2	8,5	105-114	143-155	51
B 200	ET	B (A) 4		88,9 x 80	1986	2	8,5	115-121	156-165	51
B 204	E	B (NA) 4		88,9 x 80	1986	4	10,1:1	100-103	136-140	53
B 204	FT	B (LA) 4		88,9 x 80	1986	4	8,2	102-140	139-190	54
B 21	A, E, F	B (NA) 4		92 x 80	2127	2	9,3	71-91	97-124	57
B 21	ET, FT	B (A) 4		92 x 80	2127	2	7,5	114-121	155-165	57
B 23	A, E, F	B (NA) 4		96 x 80	2316	2		78-103	106-140	62
B 23	ET, FT	B (A) 4		96 x 80	2316	2		97-127	132-173	62
B 230	A, E, K	B (NA) 4		96 x 80	2316	2		80-98	109-133	63
B 230	F, FB, FD	B (NA) 4		96 x 80	2316	2		81-118	110-160	62
B 230	G, GK	B (NA) 4		96 x 80	2316	2		90-113	122-154	62
B 230	FK, FT, FT+, FT4	B (A) 4		96 x 80	2316	2		99-151	135-205	62
B 230	ET, GT	B (LA) 4		96 x 80	2316	2	9	121-134	165-182	62
B 234	F	B (NA) 4		96 x 80	2316	4	10	111-117	151-159	64
B 27	E, F	B (NA) 6		88 x 73	2664	2		103-109	140-148	49
B 28	A, F	B (NA) 6		91 x 73	2849	2	8,8	95-114	129-155	56
B 28	E	B (NA) 6		91 x 73	2849	2	9,5-10	114-125	155-170	56
B 30	A, E, F	B (NA) 6		88,9 x 80	2978	2		92-118	125-160	50
B 4164	S3	B (NA) 4		79 x 81,4	1596	4	10,5	74	101	9
B 4164 Euro 5	T4	B (LA) 4		79 x 81,4	1596	4	10	88	120	10
B 4164 Euro 5	T2	AB (LA) 4		79 x 81,4	1596	4	10	132	180	11
B 4164	S	B (NA) 4		81 x 77	1587	4	10,5	77	105	16
B 4164	S2	B (A) 4		81 x 77	1587	4	10,3	80	109	16
B 4184	SJ, SM	B (NA) 4		81 x 89	1834	4		90-92	122-125	16
B 4184	S	B (NA) 4		83 x 80	1731	4	10,5	85	115	34
B 4184	S3	B (NA) 4		83 x 80	1731	4	10,5	85	116	34
B 4184	S2	B (NA) 4		83 x 82,4	1783	4	10,5	85-90	116-122	34
B 4184 KAT	S9	BG (NA) 4		83 x 82,4	1783	4	10,3	88-90	120-122	32
B 4184 KAT	S8	AB (NA) 4		83 x 83,1	1798	4	10,3:1	92	125	43
B 4184	S11	B (NA) 4		83 x 83,1	1798	4	10,8:1	92	125	42
B 4194	T, T2	B (A) 4		81 x 90	1855	4	8,5	147	200	17
B 4204	T14, T15, T17, T19, T20, T21, T23, T26, T31, T37, T38, T44	B (A) 4		82 x 93,2	1969	4		90-192	122-261	27
B 4204 Euro 6	T11	B (A) 4		82 x 93,2	1969	4	10	180-186	245-253	27
B 4204	S2	B (NA) 4		83 x 90	1948	4	10,3	100	136	35
B 4204	S, T, T2, T3	B (A) 4		83 x 90	1948	4		100-184	136-250	34
B 4204	T5	B (A) 4		83 x 90	1948	4	8,5	147	200	38
B 4204	S4	AB (NA) 4		87,5 x 83,1	1999	4	10,8	107	146	48
B 4204	S3	B (NA) 4		87,5 x 83,1	1999	4	10,8	107	146	46
B 4204	T6	B (A) 4		87,5 x 83,1	1999	4	10	149	203	47
B 4204	T7	B (LA) 4		87,5 x 83,1	1999	4	10	176-180	239-245	47
B 5202	S	B (NA) 5		81 x 77	1984	2	10	93	126	18
B 5204	S	B (NA) 5		81 x 77	1984	4	10,3:1	93-105	126-143	17

		Cyl.		mm	cm <sup>3</sup>		ε	kW	PS	Pos
B 5204	T, T2, T4	B (A) 5	81 x 77	1984	4			120-155	163-211	16
B 5204	T5	B (A) 5	81 x 77	1984	4	9,5		132	180	21
B 5204	T8, T9	B (A) 5	81 x 77	1984	4	9,5		132-157	180-214	22
B 5204	T3	B (LA) 5	81 x 77	1984	4	8,4		166	226	16
B 5234	S	B 5	81 x 90	2319	4	10,5:1		120	163	17
B 5234	T3	B (LA) 5	81 x 90	2319	4	8,5		147-184	239-250	16
B 5234	T1, T2, T6, T7	B (A) 5	81 x 90	2319	4			166-195	226-265	16
B 5234	T4	B (LA) 5	81 x 90	2319	4	8,5		176-184	239-250	19
B 5234	T5, T8, T9	B (A) 5	81 x 90	2319	4	8,5		177-195	241-265	17
B 5244	SG, SG2	BG (NA) 5	83 x 90	2435	4	10,3		103	140	33
B 5244	S2, S4, S5	B (NA) 5	83 x 90	2435	4	10,3		103-125	140-170	35
B 5244	S	B (NA) 5	83 x 90	2435	4	9,7		125	170	34
B 5244	T	B (A) 5	83 x 90	2435	4	9,1		142	193	36
B 5254	S	B (NA) 5	83 x 90	2435	4	10,3		121-125	165-170	34
B 5254	FS	B (NA) 5	83 x 90	2435	4	10,3		125	170	35
B 5254	T	B (A) 5	83 x 90	2435	4	9		142	193	34
B 5254	T6	B (LA) 5	83 x 93,2	2521	4	9		147	200	40
B 5254	T2	B (A) 5	83 x 93,2	2521	4	9		153-162	209-220	39
B 5254	T10, T3	B (A) 5	83 x 93,2	2521	4	9		162-170	220-231	41
B 5254	T4, T7	B (A) 5	83 x 93,2	2521	4	9		169-224	230-305	40
B 5254	T12, T14	B (A) 5	83 x 92,3	2497	4	9,5		183-187	249-254	41
B 6254	G	B (NA) 6	81 x 80	2473	4	10,5:1		125	170	17
B 6254	F, S	B (NA) 6	81 x 80	2473	4			125	170	16
B 6284	T2	B (LA) 6	81 x 90	2783	4	8,7:1		200	272	22
B 6284	T	B (LA) 6	81 x 90	2783	4	8,5		200	272	20
B 6294	S, S2	B (NA) 6	83 x 90	2922	4			144-147	196-200	37
B 6294	S3	B 6	83 x 90	2922	4	10,3:1		147	200	41
B 6294	T	B (A) 6	83 x 90	2922	4	8,5		200	272	37
B 6304	F2	B 6	83 x 90	2922	4	10,7:1		135	184	35
B 6304	S, S3	B (NA) 6	83 x 90	2922	4			150	204	34
B 6304	F	B (NA) 6	83 x 90	2922	4	10,7		150-152	204-207	35
D 10 Euro 2	A 245, A 310, A 350, C 320, C 360	D (LA) 6	120,65 x 140	9600	2			180-265	245-360	109
D 100	A, B	D (NA) 6	120,65 x 140	9600	2	17:1		122-147	166-200	107
D 100	BHC, BRC, HC	D 6	120,65 x 140	9600	2	17:1		122-147	166-200	103
D 11	A-C, A-C MP, A-D (IPS), A-D MP, A-E	D (A) 6	123 x 152	10800	4	16,5:1				116
D 11	A-C (IPS), A-E MP	D (A) 6	123 x 152	10800	4	16,5:1				118
D 11	A-A, A-B	D (LA) 6	123 x 152	10800	4	16,5:1		493	670	116
D 12 Euro 2	D-B MP	D (LA) 6	131 x 150	12130	4	17,5:1				142
D 12 Euro 3	D-G MP, D-H MP	D (LA) 6	131 x 150	12130	4					142
D 12 Euro 3	D-C MH, D-E MH	D (LA) 6	131 x 150	12130	4	17,5:1		216-405	294-550	147
D 12 Euro 2	A 370, A 415	D (LA) 6	131 x 150	12130	4	17,5:1		272-305	370-415	141
D 12 Euro 2	D-A MG, D-A MP	D (LA) 6	131 x 150	12130	4			292-526	397-715	146
D 12 Euro 2	D-A MH, D-B MH	D (LA) 6	131 x 150	12130	4	17,5:1		294-405	400-550	147
D 12 Euro 2	D-E MG	D (LA) 6	131 x 150	12130	4	17,5:1		310-370	422-503	148
D 12	C	D 6	131 x 150	12000	2	18,5:1		331	450	143
D 12 Euro 2	C-A MP	D (LA) 6	131 x 150	12130	4	16,5:1		452-526	615-715	144
D 12 Euro 3	D-E MP	D (LA) 6	131 x 150	12130	4	16,5:1		478-496	650-675	146
D 12 Euro 3	D-C MP, D-D MP, D-F MP	D (LA) 6	131 x 150	12130	4	16,5:1		478-570	650-775	148
D 120		D 6	130,175 x 150	12000	2	17:1		177	240	124
D 13	C 380 EURO5, C 420 EURO5	D (LA) 6	131 x 158	12800	4	17,8:1		280-309	380-420	157
D 13	C 460 EURO5	D (LA) 6	131 x 158	12800	4	17,8:1		338	460	150
D 13	C 500 EURO5	D (LA) 6	131 x 158	12800	4	17,8:1		368	500	151
D 13	C 540 EURO5	D (LA) 6	131 x 158	12800	4			397	540	163
D 16		D (NA) 4	78 x 83,6	1596	2	22,5		40	54	8
D 16 Euro 2	B 470	D (LA) 6	144 x 165	16120	4	17,5:1		346	470	173
D 16 Euro 2	C-A MG, C-A MH, C-B MH	D (LA) 6	144 x 165	16120	4	17,5:1		368-552	501-751	179
D 16 Euro 2	C-D MH	D (LA) 6	144 x 165	16120	4	17,5:1		368-552	501-751	181
D 16 Euro 2	C-C MH	D (LA) 6	144 x 165	16120	4	17,5:1		368-552	501-751	180
D 24		D (NA) 6	76,5 x 86,4	2383	2	23,5		58-61	79-83	6
D 24	T	D (A) 6	76,5 x 86,4	2383	2	23		79-83	107-113	7
D 24	TIC	D (LA) 6	76,5 x 86,4	2383	2	23		85-95	115-130	7
D 39	C	D (NA) 4	98,43 x 127	3866	2	16:1		59	80	67
D 41	B, D, L-A	D (A) 6	92 x 90	3590	2	17,5:1		110	150	58
D 4162	T	D (A) 4	75 x 88,3	1560	2	16		84	114	4
D 4164	T	D (LA) 4	75 x 88,3	1560	4	18,3		80-81	109-110	3
D 4192	T	D (A) 4	80 x 93	1870	2	20,5		66	90	12
D 4192	T2, T3, T4	D (A) 4	80 x 93	1870	2	19		70-85	95-116	13
D 4204	T16, T20, T4, T5, T8, T9	D (LA) 4	82 x 93,2	1969	4			88-145	120-197	28
D 4204	T11, T12, T14, T23, T6, T7	D (A) 4	82 x 93,2	1969	4			120-177	163-241	28

			Cyl.		mm	cm <sup>3</sup>		Comp. Ratio $\epsilon$	kW	PS	Pos
D 4204	T, T2	D (LA)	4	85 x 88	1998	4	19,5	96-100	131-136	45	
D 5 Euro 2	A-A TA, A-AT	D (LA)	4	108 x 130	4764	4	17,5:1	77-100	105-136	84	
D 50	A, B	D (NA)	6	95 x 120	5100	2	17:1	79-86	107-117	60	
D 5204	T, T2, T3, T4, T5, T6, T7	D (A)	5	81 x 77	1984	4	16,5	100-130	136-177	25	
D 5244 Euro 4	T3	D (LA)	5	81 x 93,2	2401	4	18	85	116	25	
D 5244 Euro 4	T6, T7, T9	D (LA)	5	81 x 93,15	2400	4	17,3	90-120	122-163	26	
D 5244 Euro 4	T, T2	D (LA)	5	81 x 93,2	2401	4	18	96-120	131-163	24	
D 5244 Euro 4	T4, T5, T8	D (LA)	5	81 x 93,15	2400	4	17,3	120-136	163-185	24	
D 5244 Euro 5	T11, T12, T14, T15, T16, T17, T18, T19, T20, T22, T23	D (LA)	5	81 x 93,15	2400	4		120-169	163-230	25	
D 5244 Euro 5	T10, T13	D (LA)	5	81 x 93,15	2400	4		132-151	180-205	26	
D 5244	T3	D (LA)	5	81 x 93,2	2401	4	17,3:1	136	185	26	
D 5244	T21	D (LA)	5	81 x 93,15	2400	4	16,5	140-162	190-220	25	
D 5252	T	D (A)	5	81 x 95,5	2460	2	20,5	103	140	23	
D 60		D	6	98,43 x 120	5480	2	17:1	84-88	115-120	66	
D 60	A	D (NA)	6	98,43 x 120	5480	2	17:1	88-92	120-125	66	
D 7	A-A TA, A-AT	D (LA)	6	108 x 130	7146	2	17,5:1	112-148	152-201	84	
D 70	B/BB, CHC, CRC	D	6	104,775 x 130	6730	2	17:1	102-110	139-150	72	
D 70	A, B	D (NA)	6	104,775 x 130	6700	2	17:1	106-110	144-150	72	
D 9 Euro 2	A2A	D (LA)	6	120 x 138	9364	4	20,2:1	221-313	300-425	94	
D 9 Euro 2	A2A MG, A2B, A2C, A2D, A2E, A2F	D (LA)	6	120 x 138	9364	4		221-423	300-575	95	
D 9 Euro 2	A2G 425, A2G 500, A2H 500, A2H 575, A2J 425, A2K 500, A2K 575	D (LA)	6	120 x 138	9364	4		313-423	425-575	100	
D 9 Euro 2	A2A 500, A2A 575, A2B 425	D (LA)	6	120 x 138	9364	4	20,2:1	313-423	425-575	101	
D10A320 Euro 2		D (A)	6	120,65 x 140	9600	2	20:1	235	320	109	
D10A360 Euro 2		D (A)	6	120,65 x 140	9600	2	20:1	265	360	109	
D10B320 Euro 2		D (LA)	6	120,65 x 140	9600	2	20:1	235	320	109	
D10B360 Euro 2		D (LA)	6	120,65 x 140	9600	2	19,5:1	265	360	109	
D11-325		D (LA)	6	123 x 152	10837	4	17:1	239	325	117	
D11-355		D (LA)	6	123 x 152	10837	4	17:1	261	355	117	
D11-365		D (LA)	6	123 x 152	10837	4	17:1	268	365	117	
D11-385		D (LA)	6	123 x 152	10837	4	17:1	283	385	117	
D11-425		D (LA)	6	123 x 152	10800	4	17:1	312	425	117	
D11A-370 Euro 3		D (LA)	6	123 x 152	10837	4	18,3:1	272	370	113	
D11A430 Euro 3		D (LA)	6	123 x 152	10837	4	18,3:1	317	431	113	
D11B1-A MP		D (A)	6	123 x 152	10840	4	16,5:1	493-533	670-725	119	
D11B2-A MP		D (A)	6	123 x 152	10840	4	16,5:1	493-533	670-725	119	
D11B3-A MP		D (A)	6	123 x 152	10840	4	16,5:1			119	
D11B4-A MP		D (A)	6	123 x 152	10840	4	16,5:1			119	
D11C330 Euro 5		D (LA)	6	123 x 152	10837	4	17,1:1	243	330	114	
D11C370 Euro 5		D (LA)	6	123 x 152	10837	4	17,3-18,3	272	370	114	
D11C410 Euro 5		D (LA)	6	123 x 152	10837	4	17,3-18,3	302	410	114	
D11C450 Euro 5		D (LA)	6	123 x 152	10837	4	17,1:1	332	450	114	
D11K330 Euro 6		D (LA)	6	123 x 152	10837	4	17,1:1	243	330	115	
D11K370 Euro 6		D (LA)	6	123 x 152	10837	4	17,1:1	272	370	115	
D11K380 Euro 6		D (LA)	6	123 x 152	10837	4	17,1:1	280	380	114	
D11K410 Euro 6		D (LA)	6	123 x 152	10837	4	17,1:1	302	410	115	
D11K430 Euro 6		D (LA)	6	123 x 152	10837	4	17,1:1	316	430	114	
D11K450 Euro 6		D (LA)	6	123 x 152	10837	4	17,1:1	332	450	115	
D11K460 Euro 6		D (LA)	6	123 x 152	10837	4	17,1:1	338	460	114	
D12A340 Euro 2		D (LA)	6	131 x 150	12130	4	17,5:1	250	340	136	
D12A380 Euro 2		D (LA)	6	131 x 150	12130	4	17,5:1	279	380	136	
D12A420 Euro 2		D (LA)	6	131 x 150	12130	4	17,5:1	309	420	136	
D12B340 Euro 2		D (LA)	6	131 x 150	12130	4		250	340	136	
D12C340 Euro 2		D (LA)	6	131 x 150	12130	4	18,5:1	250	340	137	
D12C380 Euro 3		D (LA)	6	131 x 150	12130	4	18,5:1	279	380	137	
D12C420 Euro 3		D (LA)	6	131 x 150	12130	4	18,5:1	309	420	138	
D12C460 Euro 3		D (LA)	6	131 x 150	12130	4	18,5:1	338	460	137	
D12D340 Euro 3		D (LA)	6	131 x 150	12130	4	18,1:1	250	340	139	
D12D380 Euro 3		D (LA)	6	131 x 150	12130	4	18,1:1	279	379	139	
D12D420 Euro 3		D (LA)	6	131 x 150	12130	4	18,1:1	309	420	140	
D12D425 Euro 3		D (LA)	6	131 x 150	12130	4	18,1:1	317	431	142	
D12D460 Euro 3		D (LA)	6	131 x 150	12130	4	18,1:1	338	460	139	
D12D500 Euro 3		D (LA)	6	131 x 150	12130	4	18,1:1	368	500	139	
D12F390 Euro 4		D (LA)	6	131 x 150	12130	4	17,3:1	287	390	142	
D12F430 Euro 4		D (LA)	6	131 x 150	12130	4	17,3:1	316	430	142	
D13 375		D (A)	6	131 x 158	12777	4	17:1	276	375	164	
D13 405		D (A)	6	131 x 158	12777	4	17:1	298	405	164	

			Cyl.	mm	cm <sup>3</sup>		Comp.	kW	PS	Pos
							Ratio			
D13 425	D (A)	6	6	131 x 158	12777	4	17:1	313	425	164
D13 435	D (A)	6	6	131 x 158	12777	4	17:1	320	435	164
D13 455	D (A)	6	6	131 x 158	12777	4	17:1	335	455	164
D13 500	D (A)	6	6	131 x 158	12777	4	17:1	368	500	164
D13A360 Euro 5	D (LA)	6	6	131 x 158	12777	4	18,1:1	264	360	152
D13A400 Euro 5	D (LA)	6	6	131 x 158	12777	4	18,1:1	294	400	153
D13A420	D (LA)	6	6	131 x 158	12777	4	18,1:1	309	420	154
D13A440 Euro 5	D (LA)	6	6	131 x 158	12777	4	18,1:1	324	440	152
D13A460	D (LA)	6	6	131 x 158	12777	4	18,1:1	338	460	154
D13A480 Euro 5	D (LA)	6	6	131 x 158	12777	4	18,1:1	353	480	152
D13A500 Euro 4/5	D (LA)	6	6	131 x 158	12777	4		368	500	154
D13A520 Euro 5	D (LA)	6	6	131 x 158	12777	4	18,1:1	382	520	152
D13B-A MP	D (LA)	6	6	131 x 158	12800	4	16,5:1	661	900	159
D13B-B MP	D (LA)	6	6	131 x 158	12800	4	16,7:1	588	800	159
D13B-C MP	D (LA)	6	6	131 x 158	12800	4	16,5:1	558	800	159
D13B-D MP	D (LA)	6	6	131 x 158	12800	4	16,7:1	515	700	159
D13B-E MG (FE)	D (LA)	6	6	131 x 158	12800	4	16,7:1	300	408	165
D13B-E MG	D (LA)	6	6	131 x 158	12800	4	16,7:1	300-400	408-544	161
D13B-E MH	D (LA)	6	6	131 x 158	12800	4	16,7:1	294-441	400-600	166
D13B-F MG (FE)	D (LA)	6	6	131 x 158	12800	4	16,7:1	358	487	165
D13B-F MG	D (LA)	6	6	131 x 158	12800	4	16,7:1	358-400	487-544	161
D13B-G MP	D (LA)	6	6	131 x 158	12800	4	16,5:1	588-661	800-900	159
D13B-H MP	D (LA)	6	6	131 x 158	12800	4	16,5:1	661	900	159
D13B-J MP	D (LA)	6	6	131 x 158	12800	4	16,5:1	661	900	159
D13B-K MP	D (LA)	6	6	131 x 158	12800	4	16,5:1	588	800	159
D13B-L MP	D (LA)	6	6	131 x 158	12800	4	16,5:1	588	800	159
D13B-M MP	D (LA)	6	6	131 x 158	12800	4	16,7:1	515	700	159
D13B-N MH	D (LA)	6	6	131 x 158	12800	4	16,7:1	294-441	400-600	166
D13B360 Euro 4/5	D (LA)	6	6	131 x 158	12777	4	18,1:1	264	360	155
D13B400 Euro 4/5	D (LA)	6	6	131 x 158	12777	4	18,1:1	294	400	155
D13B440 Euro 4/5	D (LA)	6	6	131 x 158	12777	4	18,1:1	324	440	155
D13B500 Euro 4/5	D (LA)	6	6	131 x 158	12777	4	18,1:1	368	500	155
D13C1-A MG	D (A)	6	6	131 x 158	12800	4				167
D13C1-A MH	D (A)	6	6	131 x 158	12800	4				161
D13C1-A MP	D (A)	6	6	131 x 158	12800	4				168
D13C2-A MG	D (A)	6	6	131 x 158	12800	4				167
D13C2-A MH	D (A)	6	6	131 x 158	12800	4				161
D13C2-A MP	D (A)	6	6	131 x 158	12800	4				168
D13C380 Euro 5	D (LA)	6	6	131 x 158	12777	4	18,1:1	280-285	380-388	157
D13C420 Euro 5	D (LA)	6	6	131 x 158	12777	4	18,1:1	309	420	157
D13C460 Euro 5	D (LA)	6	6	131 x 158	12777	4	18,1:1	338-343	460-466	150
D13C500 Euro 5	D (LA)	6	6	131 x 158	12777	4	18,1:1	368	500	151
D13C540 Euro 5	D (LA)	6	6	131 x 158	12777	4	18,1:1	397	540	151
D13K420 Euro 6	D (LA)	6	6	131 x 158	12777	4	17,0:1	309	420	156
D13K460 Euro 6	D (LA)	6	6	131 x 158	12777	4	17,0:1	338	460	156
D13K500 Euro 6	D (LA)	6	6	131 x 158	12777	4	17,0:1	368	500	162
D13K540 Euro 6	D (LA)	6	6	131 x 158	12777	4	17,0:1	397	540	162
D16A470 Euro 2	D (LA)	6	6	144 x 165	16123	4	17,5:1	346	470	173
D16A520 Euro 1	D (LA)	6	6	144 x 165	16123	4	17,5:1	382	520	173
D16B520 Euro 2	D (LA)	6	6	144 x 165	16123	4	17,5:1	382	520	173
D16C550 Euro 3	D (LA)	6	6	144 x 165	16123	4	18:1	404	549	177
D16C610 Euro 3	D (LA)	6	6	144 x 165	16123	4	18:1	449	610	177
D16E540 Euro 4	D (LA)	6	6	144 x 165	16123	4	17,3:1	396	540	177
D16E580 Euro 4	D (LA)	6	6	144 x 165	16123	4	17,3:1	426	580	177
D16E660 Euro 4	D (LA)	6	6	144 x 165	16123	4	17,3:1	485	660	177
D16G540 Euro 5	D (LA)	6	6	144 x 165	16123	4	17,3:1	396	540	177
D16G600 Euro 5	D (LA)	6	6	144 x 165	16123	4	17,3:1	441	600	177
D16G700 Euro 5	D (LA)	6	6	144 x 165	16123	4	17,3:1	515	700	177
D16G750 Euro 5	D (LA)	6	6	144 x 165	16123	4	17,3:1	551-552	749-751	177
D5A-B TA Euro 1	D (LA)	4	4	108 x 130	4764	2	17,5:1	89-118	121-160	84
D5A-T Euro 1	D (A)	4	4	108 x 130	4764	2	17,5:1	77-81	105-110	84
D5A-TA Euro 1	D (LA)	4	4	108 x 130	4764	2	17,5:1	89-118	121-160	84
D5K240 Euro 6	D (LA)	4	4	110 x 135	5132	4	17,5:1	176-177	239-241	91
D7A-B TA Euro 1	D (LA)	6	6	108 x 130	7145	2	17,6:1	130-174	177-237	85
D7A-T Euro 1	D (A)	6	6	108 x 130	7145	2	17,5:1	116-122	158-166	85
D7A-TA Euro 1	D (LA)	6	6	108 x 130	7145	2	17,5:1	130-174	177-237	85
D7A230 Euro 2	D (LA)	6	6	104,775 x 130	6700	2	18:1	169	230	74
D7A260 Euro 2	D (LA)	6	6	104,775 x 130	6700	2	18:1	191	260	74
D7A285 Euro 2	D (LA)	6	6	104,775 x 130	6700	2	18:1	210	286	74



			Cyl.		mm	cm <sup>3</sup>		Comp. Ratio $\epsilon$	kW	PS	Pos
D7B230 Euro 2			D (LA) 6		104,775 x 130	6700	2	18:1	169	230	74
D7B260 Euro 2			D (LA) 6		104,775 x 130	6700	2	18:1	191	260	74
D7C-B TA Euro 1			D (LA) 6		108 x 130	7145	2	17,6:1	146-195	199-265	85
D7C-TA Euro 1			D (LA) 6		108 x 130	7145	2	17,6:1	146-195	199-265	85
D7C215 Euro 2			D (LA) 6		107 x 135	7284	2	19:1	158	215	79
D7C250 Euro 2			D (LA) 6		107 x 135	7300	2	19,5:1	184	250	79
D7C290 Euro 2			D (LA) 6		107 x 135	7284	2	19,5:1	213	290	79
D7C310 Euro 2			D (LA) 6		107 x 135	7284	2	19,5:1	228	310	79
D7D EAE2			D (LA) 6		108 x 130	7146	4		143-153	194-208	90
D7E 240 Euro 4			D (LA) 6		108 x 130	7146	4	18:1	177	240	88
D7E 280 Euro 4/5			D (LA) 6		108 x 130	7146	4	18:1	206	280	88
D7E 290 Euro 5			D (LA) 6		108 x 130	7146	4	18:1	213	290	83
D7E 320 Euro 4/5			D (LA) 6		108 x 130	7146	4	18:1	235	320	88
D7E 360 Euro 4/5			D (LA) 6		108 x 130	7146	4	18,1	265	360	83
D8A1-A MP Euro 2			D	6	110 x 135	7700	4	16,5:1	661	550	92
D8A4-A MP Euro 2			D	6	110 x 135	7700	4	16,5:1			92
D8K250 Euro 6			D (LA) 6		110 x 135	7698	4	17,5:1	184	250	91
D8K280 Euro 6			D (LA) 6		110 x 135	7698	4	17,5:1	206	280	91
D8K320 Euro 6			D (LA) 6		110 x 135	7698	4	17,5:1	235	320	91
D8K350 Euro 6			D (LA) 6		110 x 135	7698	4	17,5:1	258	350	91
D9A260 Euro 3			D (LA) 6		120 x 138	9364	4	18,6:1	191	260	94
D9A300 Euro 3			D (LA) 6		120 x 138	9364	4	18,6:1	221-224	300-305	94
D9A340 Euro 3			D (LA) 6		120 x 138	9364	4	18,6:1	250-251	340-341	94
D9A380 Euro 3			D (LA) 6		120 x 138	9364	4	18,6:1	279	380	94
D9B260 Euro 5			D (LA) 6		120 x 138	9364	4	18,5:1	191-194	260-264	93
D9B300 Euro 4			D (LA) 6		120 x 138	9364	4	18,5:1	221	300	93
D9B310 Euro 5			D (LA) 6		120 x 138	9364	4	18,5:1	228	310	93
D9B340 Euro 4			D (LA) 6		120 x 138	9364	4	18,5:1	250	340	93
D9B360 Euro 4/5			D (LA) 6		120 x 138	9364	4	18,5:1	265	360	93
D9B380 Euro 4			D (LA) 6		120 x 138	9364	4	18,5:1	280	380	93
DH 10 Euro 2	A 340, A 350		D (LA) 6		120,65 x 140	9600	2	20:1	250-257	340-350	109
DH 12 Euro 3	H 340		D (LA) 6		131 x 150	12130	4	18,5:1	249	340	142
DH10A245 Euro 2			D (LA) 6		120,65 x 140	9600	2	20:1	180	245	109
DH10A285 Euro 2			D (LA) 6		120,65 x 140	9600	2	20:1	210	285	109
DH10A360 Euro 2			D (LA) 6		120,65 x 140	9600	2	18-20:1	265	360	109
DH12D340 Euro 3			D (LA) 6		131 x 150	12130	4	18,5:1	250	340	142
DH12D380 Euro 3			D (LA) 6		131 x 150	12130	4	18,5:1	280	380	142
DH12D420 Euro 3			D (LA) 6		131 x 150	12130	4	18,5:1	309	420	142
DH12E340 Euro 5			D (LA) 6		131 x 150	12130	4	18,1:1	250	340	142
DH12E380 Euro 4			D (LA) 6		131 x 150	12130	4	18,1:1	280	380	142
DH12E420 Euro 5			D (LA) 6		131 x 150	12130	4	18,1:1	309	420	142
DH12E460 Euro 4			D (LA) 6		131 x 150	12130	4	18,1:1	338	460	142
HD 100	D		D (NA) 6		120,65 x 140	9600	2	17:1	125-132	170-180	104
KAD 42	A, B, P-A		D (LA) 6		92 x 90	3590	2	17,8:1	169	230	58
KAD 43	P-A		D (LA) 6		92 x 90	3590	2	17,5:1	169	230	58
KAMD 300-A			D (LA) 6		92 x 90	3590	4	16,9:1	210	285	58
KAMD 42	A, B, P-A		D (LA) 6		92 x 90	3590	2		169	230	58
KAMD 43	P-A		D (LA) 6		92 x 90	3590	2	17,5:1	169	230	59
KAMD 44	P-C		D (LA) 6		92 x 90	3590	4	16,9:1	191	260	58
MD 100	A, B		D	6	120,65 x 140	9600	2	17:1	98-147	133-200	105
MD 11			D (LA) 1		89 x 90		4				55
MD 40	A		D	6	92 x 90	3598	2	21:1	53-63	72-85	58
MD 70	B, C		D	6	104,775 x 130	6730	2	17:1	73-107	99-145	72
TAD 1030 Euro 1	GE		D (LA) 6		120 x 140	9600	2	17:1	222-258	302-351	102
TAD 1032	GE		D (LA) 6		120 x 140	9600	2	17:1	240-262	326-356	102
TAD 120	BHC		D (A) 6		130,175 x 150	11980	2	13,3:1	225-273	306-371	127
TAD 121	CHC		D (NA) 6		130,175 x 150	11980	2	14,2:1	238	324	125
TAD 1230	G		D (LA) 6		130,175 x 150	11980	2	16:1	294-349	400-475	132
TAD 1231 Euro 1	GE		D (LA) 6		130,175 x 150	11980	2	16:1	260-304	354-413	133
TAD 1232 Euro 1	GE		D (LA) 6		130,175 x 150	11980	2	17,5:1	300-354	408-481	133
TAD 1250 Euro 3	VE		D (LA) 6		131 x 150	12130	2	18,1:1	259	352	149
TAD 1251 Euro 3	VE		D (LA) 6		131 x 150	12130	2	18,1:1	289	393	149
TAD 1252 Euro 3	VE		D (LA) 6		131 x 150	12130	2	18,1:1	313	426	149
TAD 1344	GE-B		D (LA) 6		131 x 158	12780	2				169
TAD 1345	GE-B		D (LA) 6		131 x 158	12780	2				169
TAD 1630	PB		D (LA) 6		144 x 165	16120	2				174
TAD 530	GE EDC4, GE MECH		D (LA) 4		108 x 130	4760	2	18:1	74-85	101-115	86
TAD 531	GE EDC4, GE MECH		D (LA) 4		108 x 130	4760	2	18:1	88-104	119-141	86
TAD 532	GE EDC4		D (LA) 4		108 x 130	4760	2	18:1	112-129	152-176	86

									Comp. Ratio $\epsilon$	kW	PS	Pos
					Cyl.	mm	cm <sup>3</sup>					
TAD 730	GE EDC4, GE MECH	D (LA)	6	108 x 130	7150	2	18:1	111-127	151-173	86		
TAD 731	GE EDC4, GE MECH	D (LA)	6	108 x 130	7150	2	18:1	132-156	180-210	86		
TAD 732	GE EDC4	D (LA)	6	108 x 130	7150	2	18:1	157-192	214-261	86		
TAD 733	GE EDC4	D (LA)	6	108 x 130	7150	2	18:1	174-213	236-289	86		
TAD 850 Euro 3	VE	D	6	110 x 135	7700	4	17,5	160	218	92		
TAD 880 Euro 5	VE	D	6	110 x 135	7700	4	17,2	160	218	92		
TAD 881 Euro 5	VE	D	6	110 x 135	7700	4	17,2	185	252	92		
TAD 882 Euro 5	VE	D	6	110 x 135	7700	4	17,2	210	286	92		
TAD 883 Euro 5	VE	D	6	110 x 135	7700	4	17,2	235	320	92		
TAD 884 Euro 5	VE	D	6	110 x 135	7700	4	17,2	250	340	92		
TAD1140VE Euro 2		D (LA)	6	123 x 152	10837	4	17:1	235	320	120		
TAD1141VE Euro 2		D (LA)	6	123 x 152	10837	4	17:1	265	360	120		
TAD1142VE Euro 2		D (LA)	6	123 x 152	10837	4	17:1	285	387	120		
TAD1150VE Euro 3		D (LA)	6	123 x 152	10837	4	17:1	235	320	120		
TAD1151VE Euro 3		D (LA)	6	123 x 152	10837	4	17:1	265	360	120		
TAD1152VE Euro 3		D (LA)	6	123 x 152	10837	4	17:1	285	387	120		
TAD1170VE Euro 4		D (LA)	6	123 x 152	10837	4	17:1	235	320	120		
TAD1171VE Euro 4		D (LA)	6	123 x 152	10837	4	17:1	265	360	120		
TAD1172VE Euro 4		D (LA)	6	123 x 152	10837	4	17:1	285	387	120		
TAD1240GE Euro 2		D (LA)	6	131 x 150	12130	4	17,5:1	310-346	421-470	145		
TAD1241GE Euro 2		D (LA)	6	131 x 150	12130	4	17,5:1	323-387	439-526	145		
TAD1241VE Euro 2		D (LA)	6	131 x 150	12130	4	17,5:1	343	466	146		
TAD1242GE Euro 2		D (LA)	6	131 x 150	12130	4	17,5:1	352-430	479-585	145		
TAD1242VE Euro 2		D (LA)	6	131 x 150	12130	4	17,5:1	383	521	146		
TAD1340VE Euro 2		D (LA)	6	131 x 158	12777	4	18,1:1	240-256	326-348	158		
TAD1341GE Euro 2		D (LA)	6	131 x 158	12777	4	18,1:1	275-324	374-441	158		
TAD1341VE Euro 2		D (LA)	6	131 x 158	12777	4	18,1:1	259-275	352-374	158		
TAD1342GE Euro 2		D (LA)	6	131 x 158	12777	4	18,1:1	303-377	412-513	158		
TAD1342VE Euro 2		D (LA)	6	131 x 158	12777	4	18,1:1	294-310	400-421	158		
TAD1343GE Euro 2		D (LA)	6	131 x 158	12777	4	18,1:1	325-388	442-528	158		
TAD1343VE Euro 2		D (LA)	6	131 x 158	12777	4	18,1:1	316-332	430-451	160		
TAD1344GE Euro 2		D (LA)	6	131 x 158	12777	4	18,1:1	354-431	481-586	158		
TAD1344VE Euro 2		D (LA)	6	131 x 158	12777	4	18,1:1	336-352	457-479	158		
TAD1345GE Euro 2		D (LA)	6	131 x 158	12777	4	18,1:1	388-431	528-586	158		
TAD1345VE Euro 2		D (LA)	6	131 x 158	12777	4	18,1:1	377-394	513-536	158		
TAD1350GE Euro 3		D (LA)	6	131 x 158	12777	4	18,1:1	245-269	333-366	158		
TAD1350VE Euro 2		D (LA)	6	131 x 158	12777	4	18,1:1	256	348	158		
TAD1351GE Euro 3		D (LA)	6	131 x 158	12777	4	18,1:1	279-323	379-439	158		
TAD1351VE Euro 2		D (LA)	6	131 x 158	12777	4	17,8:1	285	387	170		
TAD1352GE Euro 3		D (LA)	6	131 x 158	12777	4	18,1:1	314-376	427-511	158		
TAD1352VE Euro 2		D (LA)	6	131 x 158	12777	4	17,8:1	315	428	158		
TAD1353GE Euro 3		D (LA)	6	131 x 158	12777	4	18,1:1	391-430	532-585	158		
TAD1353VE Euro 2		D (LA)	6	131 x 158	12777	4	17,8:1	345	469	170		
TAD1354GE Euro 3		D (LA)	6	131 x 158	12777	4	18,1:1	328-376	446-511	158		
TAD1355GE Euro 3		D (LA)	6	131 x 158	12777	4	18,1:1	344-390	468-530	158		
TAD1360VE		D (LA)	6	131 x 158	12777	4	18,1:1	256	348	158		
TAD1361VE		D (LA)	6	131 x 158	12777	4	18,1:1	285	387	158		
TAD1362VE		D (LA)	6	131 x 158	12777	4	18,1:1	315	428	158		
TAD1363VE		D (LA)	6	131 x 158	12777	4	18,1:1	345	469	158		
TAD1364VE		D (LA)	6	131 x 158	12777	4	18,1:1	375	510	158		
TAD1365VE		D (LA)	6	131 x 158	12777	4	18,1:1	405	551	158		
TAD1371VE Euro 4		D (LA)	6	131 x 158	12777	4	17,8:1	285	387	171		
TAD1372VE Euro 4		D (LA)	6	131 x 158	12777	4	17,8:1	315	428	171		
TAD1373VE Euro 4		D (LA)	6	131 x 158	12777	4	17,8:1	345	469	171		
TAD1374VE Euro 4		D (LA)	6	131 x 158	12777	4	17,8:1	375	510	171		
TAD1375VE Euro 4		D (LA)	6	131 x 158	12777	4	17,8:1	405	551	172		
TAD1630G		D (LA)	6	144 x 165	16123	4	15:1	395-474	537-644	175		
TAD1630GE Euro 1		D (LA)	6	144 x 165	16120	4	15:1	360-395	490-537	174		
TAD1630P		D (LA)	6	144 x 165	16123	4	15:1	330-415	449-564	175		
TAD1630V		D (LA)	6	144 x 165	16123	4	15:1	330-415	449-564	175		
TAD1631G		D (LA)	6	144 x 165	16123	4	15:1	435-546	591-742	175		
TAD1631GE		D (LA)	6	144 x 165	16123	4	15:1	435-546	591-742	175		
TAD1640GE Euro 2		D (LA)	6	144 x 165	16123	4	17,5:1	393-480	534-653	178		
TAD1640VE-B Euro 2		D (LA)	6	144 x 165	16123	4	16,8:1	405	551	178		
TAD1641GE Euro 2		D (LA)	6	144 x 165	16123	4	16,5:1	430-546	585-742	178		
TAD1641VE Euro 2		D (LA)	6	144 x 165	16123	4	17,5:1	406-420	552-571	178		
TAD1641VE-B Euro 2		D (LA)	6	144 x 165	16123	4	16,8:1	450	612	178		
TAD1642GE Euro 2		D (LA)	6	144 x 165	16123	4	16,5:1	503-585	684-795	178		
TAD1642VE Euro 2		D (LA)	6	144 x 165	16123	4	17,5:1	480-494	653-672	178		

		Cyl.		mm	cm <sup>3</sup>		Comp. Ratio $\epsilon$	kW	PS	Pos
TAD1642VE-B Euro 2	D (LA)	6	144 x 165	16123	4	16,8:1	515	700	178	
TAD1643VE Euro 2	D (LA)	6	144 x 165	16123	4	17,5:1	543-565	738-768	178	
TAD1643VE-B Euro 2	D (LA)	6	144 x 165	16123	4	17:1	565	768	178	
TAD1650GE Euro 3	D (LA)	6	144 x 165	16123	4	16,5:1	393-479	534-651	178	
TAD1650VE Euro 3	D (LA)	6	144 x 165	16123	4	18:1	397	540	178	
TAD1650VE-B Euro 3	D (LA)	6	144 x 165	16123	4	17:1	405	551	179	
TAD1651GE Euro 3	D (LA)	6	144 x 165	16123	4	16,5:1	430-546	585-742	178	
TAD1651VE Euro 3	D (LA)	6	144 x 165	16123	4	17:1	450	612	179	
TAD1660VE Euro 3	D (LA)	6	144 x 165	16123	4	16,8:1	405	551	178	
TAD1661VE Euro 3	D (LA)	6	144 x 165	16123	4	16,8:1	450	612	178	
TAD1662VE Euro 3	D (LA)	6	144 x 165	16123	4	16,8:1	515	700	178	
TAD1670VE Euro 4	D (LA)	6	144 x 165	16123	4	16,8:1	405	551	182	
TAD1671VE Euro 4	D (LA)	6	144 x 165	16123	4	16,8:1	450	612	182	
TAD1672VE Euro 4	D (LA)	6	144 x 165	16123	4	16,8:1	515	700	182	
TAD520GE Euro 2	D (LA)	4	108 x 130	4764	2	17,5:1	94-110	128-150	84	
TAD520VE Euro 2	D (LA)	4	108 x 130	4764	2	18,1-19	107-118	145-160	84	
TAD530GE Euro 2	D (LA)	4	108 x 130	4764	2	18:1	75-85	102-116	84	
TAD531GE Euro 2	D (LA)	4	108 x 130	4764	2	18:1	88-101	120-137	84	
TAD532GE Euro 2	D (LA)	4	108 x 130	4764	2	18:1	113-126	154-171	87	
TAD540VE Euro 2	D (LA)	4	110 x 135	5132	4	17,5:1	105	143	91	
TAD541VE Euro 2	D (LA)	4	110 x 135	5132	4	17,5:1	129	175	91	
TAD542VE Euro 2	D (LA)	4	110 x 135	5132	4	17,5:1	160	218	91	
TAD550GE Euro 3	D (LA)	4	108 x 130	4764	2	18:1	76-94	103-128	87	
TAD550VE Euro 3	D (LA)	4	110 x 135	5132	4	17,5	105	143	91	
TAD551GE Euro 3	D (LA)	4	108 x 130	4764	2	18:1	89-110	121-150	87	
TAD551VE Euro 3	D (LA)	4	110 x 135	5132	4	17,5	129	175	91	
TAD552VE Euro 3	D (LA)	4	110 x 135	5132	4	17,5	160	218	91	
TAD560VE	D (LA)	4	108 x 130	4764	4	17,3:1	129	175	89	
TAD561VE	D (LA)	4	108 x 130	4764	4	17,3:1	155	211	89	
TAD570VE Euro 4	D (LA)	4	110 x 135	5132	4	17,5:1	105	143	91	
TAD571VE Euro 4	D (LA)	4	110 x 135	5132	4	17,5:1	129	175	91	
TAD572VE Euro 4	D (LA)	4	110 x 135	5132	4	17,5:1	160	218	91	
TAD650VE Euro 3	D (LA)	6	101 x 126	6057	2	18,4:1	147	200	70	
TAD660VE Euro 3	D (LA)	6	98 x 126	5702	2	18,4:1	147	200	65	
TAD720GE Euro 2	D (LA)	6	108 x 130	7145	2	17,5:1	140-163	190-222	84	
TAD720VE Euro 2	D (LA)	6	108 x 130	7145	2	18,4-19	157-174	213-237	84	
TAD721GE Euro 2	D (LA)	6	108 x 130	7145	2	18,1:1	162-197	220-268	87	
TAD721VE Euro 2	D (LA)	6	108 x 130	7145	2	18,4-19	176-195	239-265	84	
TAD722GE Euro 2	D (LA)	6	108 x 130	7145	2	18,1:1	179-218	243-296	87	
TAD722VE Euro 2	D (LA)	6	108 x 130	7145	2	19:1	212-220	288-299	84	
TAD730GE Euro 2	D (LA)	6	108 x 130	7145	2	18:1	111-127	151-173	84	
TAD731GE Euro 2	D (LA)	6	108 x 130	7145	2	18:1	134-153	182-208	84	
TAD732GE Euro 2	D (LA)	6	108 x 130	7145	2	18:1	159-192	216-261	87	
TAD733GE Euro 2	D (LA)	6	108 x 130	7145	2	18:1	176-213	239-290	87	
TAD734GE Euro 2	D (LA)	6	108 x 130	7145	4	17:1	219-247	298-336	89	
TAD740GE Euro 1	D (LA)	6	107 x 135	7284	2	17,2:1	220-251	299-341	80	
TAD741GE Euro 1	D (LA)	6	107 x 135	7284	2	17,2:1	232	316	80	
TAD750GE Euro 3	D (LA)	6	108 x 130	7145	2	18,1:1	113-141	154-192	87	
TAD750VE Euro 3	D (LA)	6	108 x 130	7145	2	18,0:1	170-200	231-272	87	
TAD751GE Euro 3	D (LA)	6	108 x 130	7145	2	18,0:1	132-166	179-226	87	
TAD752GE Euro 3	D (LA)	6	108 x 130	7145	4	18,1:1	158-196	215-266	89	
TAD753GE Euro 3	D (LA)	6	108 x 130	7145	4	18,1:1	175-218	238-296	89	
TAD754GE Euro 3	D (LA)	6	108 x 130	7145	4	17,0:1	219-245	298-333	89	
TAD760VE Euro 3	D (LA)	6	108 x 130	7145	2	18,1:1	180	245	87	
TAD761VE Euro 3	D (LA)	6	108 x 130	7145	4	17,3:1	160	218	89	
TAD762VE Euro 3	D (LA)	6	108 x 130	7145	4	17,3:1	185	252	89	
TAD763VE Euro 3	D (LA)	6	108 x 130	7145	4	17,3:1	210	286	89	
TAD764VE Euro 3	D (LA)	6	108 x 130	7145	4	17,3:1	225	306	89	
TAD765VE Euro 3	D (LA)	6	108 x 130	7145	4	17,3:1	235	320	89	
TAD840VE Euro 2	D (LA)	6	110 x 135	7698	4	17,5:1	160	218	91	
TAD841VE Euro 2	D (LA)	6	110 x 135	7698	4	17,5:1	185	252	91	
TAD842VE Euro 2	D (LA)	6	110 x 135	7698	4	17,5:1	210	286	91	
TAD843VE Euro 2	D (LA)	6	110 x 135	7698	4	17,5:1	235	320	91	
TAD851VE Euro 3	D (LA)	6	110 x 135	7698	4	17,5:1	185	252	91	
TAD852VE Euro 3	D (LA)	6	110 x 135	7698	4	17,5:1	210	286	91	
TAD853VE Euro 3	D (LA)	6	110 x 135	7698	4	17,5:1	235	320	91	
TAD870VE Euro 4	D (LA)	6	110 x 135	7698	4	17,5:1	160	218	91	
TAD871VE Euro 4	D (LA)	6	110 x 135	7698	4	17,5:1	185	252	91	
TAD872VE Euro 4	D (LA)	6	110 x 135	7698	4	17,5:1	210	286	91	



			Cyl.		mm	cm <sup>3</sup>		Comp. Ratio $\epsilon$	kW	PS	Pos
TAD873VE Euro 4	D (LA)	6	110 x 135	7698	4	17,5:1	235	320	91		
TAD940GE Euro 2	D (LA)	6	120 x 138	9364	4	20,2:1	240-273	326-371	96		
TAD940VE Euro 2	D (LA)	6	120 x 138	9364	4	20,2:1	171-190	232-258	97		
TAD941GE Euro 2	D (LA)	6	120 x 138	9364	4	17,4:1	281-323	382-439	98		
TAD941VE Euro 2	D (LA)	6	120 x 138	9364	4	20,2:1	201-220	273-299	97		
TAD942VE Euro 2	D (LA)	6	120 x 138	9364	4	20,2:1	235-250	320-340	97		
TAD943VE Euro 2	D (LA)	6	120 x 138	9364	4	20,2:1	236-279	321-379	97		
TAD950VE Euro 3	D (LA)	6	120 x 138	9364	4	20,2:1	178-191	242-260	99		
TAD951VE Euro 3	D (LA)	6	120 x 138	9364	4	20,2:1	205-224	279-305	99		
TAD952VE Euro 3	D (LA)	6	120 x 138	9364	4	20,2:1	234-252	318-343	99		
TAMD 102	A, D	D (LA)	6	120,65 x 140	9600	2	14,3:1	235-346	320-470	112	
TAMD 103	A-A	D (LA)	6	120,65 x 140	9600	2	17:1	199-287	270-390	112	
TAMD 120	AK, BCC	D (LA)	6	130,175 x 150	12000	2	14,2:1	227-265	308-360	127	
TAMD 120	A, B	D (LA)	6	130,175 x 150	12000	2	14,2:1	227-294	308-400	125	
TAMD 121	D	D (A)	6	130,175 x 150	12000	2	14,2:1	217-310	295-420	125	
TAMD 121	C	D (LA)	6	130,175 x 150	12000	2	14,2:1	300	408	125	
TAMD 122	C, D	D (LA)	6	130,175 x 150	12000	2	14,2:1	127-340	173-462	125	
TAMD 122	A, P-A, P-B, P-C	D (LA)	6	130,175 x 150	12000	2	14,2:1	135-449	183-610	127	
TAMD 162	C-C	D (LA)	6	144 x 165	16120	2	17:1	375	510	174	
TAMD 163	A-A, P-A	D (LA)	6	144 x 165	16120	2	17:1	404-566	550-770	174	
TAMD 165	A-A, C-A	D (LA)	6	144 x 165	16120	2	17:1	375-404	510-550	174	
TAMD 165	A, C, P, P-A	D (LA)	6	144 x 165	16120	2	17:1	375-552	510-751	176	
TAMD 31	A, B, D, L-A, M-A, P-A, S-A	D (LA)	4	92 x 90	2394	2		74-110	100-150	58	
TAMD 40	A	D (LA)	6	92 x 90	3598	2	21:1	81-109	110-148	58	
TAMD 41	A, B, D, H-A, M-A, P-A	D (LA)	6	92 x 90	3598	2		107-147	145-200	58	
TAMD 42	W-JA	D (LA)	6	92 x 90	3598	2	17,5:1	169	230	59	
TAMD 42	B	D (LA)	6	92 x 90	3598	2	17,8:1	169	230	58	
TAMD 60	C	D (A)	6	98,43 x 120	5480	2	16:1	108-184	147-250	68	
TAMD 61	A	D (LA)	6	98,43 x 120	5480	2	15:1	225	306	68	
TAMD 70	A, B, C, D, E	D (LA)	6	104,775 x 130	6730	2		114-221	155-300	73	
TAMD 71	A, B, D	D (LA)	6	104,775 x 130	6730	2	14:1	160-263	218-357	73	
TAMD 72	A, P-A, WJ-A	D (LA)	6	104,775 x 130	6730	2	15,6:1	316-331	430-450	76	
TAMD 73	P-A, WJ-A	D (LA)	6	104,775 x 130	6730	2	15,6:1	316-331	430-450	76	
TAMD74A		D (LA)	6	107 x 135	7284	2	17,2:1	154-257	209-349	81	
TAMD74A-A		D (LA)	6	107 x 135	7284	2	17,2:1	154-257	209-349	80	
TAMD74A-B		D (LA)	6	107 x 135	7284	2	17,2:1	154-257	209-349	80	
TAMD74C-A		D (LA)	6	107 x 135	7284	2	17,2:1	294-331	400-450	80	
TAMD74C-B		D (LA)	6	107 x 135	7284	2	17,2:1	294-331	400-450	80	
TAMD74L-A		D (LA)	6	107 x 135	7284	2	17,2:1	316	430	80	
TAMD74L-B		D (LA)	6	107 x 135	7284	2	17,2:1	316	430	80	
TAMD74P-A Euro 2		D (LA)	6	107 x 135	7284	2	17,2:1	353	480	80	
TAMD74P-B Euro 2		D (LA)	6	107 x 135	7284	2	17,2:1	353	480	80	
TD 100	AG, AHC, ARC, B, BG, F, GG	D (A)	6	120,65 x 140	9600	2		137-220	186-299	104	
TD 100	HC	D (A)	6	120,65 x 140	9600	2	15/17:1	169-191	230-260	105	
TD 100	A, C	D (A)	6	120,65 x 140	9600	2		176-190	239-258	108	
TD 100	CHC, G, GA	D (A)	6	120,65 x 140	9600	2	14,3:1	192-213	261-290	106	
TD 101	GB, GE, KC, MC	D (LA)	6	120,65 x 140	9600	2		185-228	252-310	105	
TD 101	G	D (A)	6	120,65 x 140	9600	2	14,3:1	192-202	261-275	104	
TD 101	GG	D (LA)	6	120,65 x 140	9600	2	14,3:1	200	272	106	
TD 101	F, FA, FC, FD, GA	D (LA)	6	120,65 x 140	9600	2	14,3:1	200-222	272-302	104	
TD 102	FAQ, FBQ, FCQ, FEQ, FGQ, FS	D (LA)	6	120,65 x 140	9600	2	15:1	191-250	260-340	105	
TD 102	FDQ, FF, FH, FM, FQ	D (LA)	6	120,65 x 140	9600	2		210-252	286-343	104	
TD 102 Euro 1	FT	D (LA)	6	120,65 x 140	9600	2	15:1	228	310	105	
TD 102 Euro 1	F, FD	D (LA)	6	120,65 x 140	9600	2	15:1	230-234	313-318	104	
TD 102 Euro 1	FL	D (A)	6	120,65 x 140	9600	2	16:1	234	318	104	
TD 103 Euro 2	KAE	D (LA)	6	120,65 x 140	9600	2	18:1	190	258	105	
TD 103 Euro 1	E	D (LA)	6	120,65 x 140	9600	2	18:1	210-235	286-320	104	
TD 103 Euro 1	KB, KF, ME	D (LA)	6	120,65 x 140	9600	2		210-235	286-320	105	
TD 103 Euro 1	EA, ES	D (A)	6	120,65 x 140	9600	2	18:1	210-235	286-320	104	
TD 104 Euro 2	KAE	D (LA)	6	120,65 x 140	9600	2	18:1	190	258	106	
TD 120	A, C, D, E, G, GA, GG	D (A)	6	130,175 x 150		2		178-273	242-371	126	
TD 120	F, FA, FB, FC, FTQ	D (LA)	6	130,175 x 150	11980	2	14,2:1	213-265	290-360	126	
TD 121	G, GD	D (A)	6	130,17 x 150	11980	2	14,2:1	235-243	320-330	122	
TD 121	F	D (LA)	6	130,17 x 150	11980	2	14,2:1	272-283	370-385	122	
TD 121	FA, FB, FC, FD, FE, FF, FG, FH, FK, GG, GP	D (LA)	6	130,175 x 150		2		206-283	280-385	126	
TD 121	A	D (A)	6	130,175 x 150	12000	2	14,2:1	243	330	126	
TD 1210	G	D (LA)	6	130,175 x 150	12000	2		230	313	131	
TD 122	F	D (A)	6	130 x 150	11980	2	15:1	257-262	350-356	121	



				Cyl.		mm	cm <sup>3</sup>		Comp. Ratio $\epsilon$	kW	PS	Pos
TD 122	FS	D (LA)	6	130,17 x 150	11980	2	15:1	287-291	395-396	122		
TD 122	ED, F (USA), FAQ, FBQ, FCQ, FK, FKQ, FR, GA, GB, GH, KBE, KE, KHD	D (LA)	6	130,175 x 150	11980	2		179-396	243-538	126		
TD 122	FA, FTO	D (A)	6	130,175 x 150	11980	2	16:1	221-396	300-538	126		
TD 122 Euro 1	FH	D (LA)	6	130,18 x 150	11980	2	16:1	262	356	135		
TD 122	FL	D (LA)	6	130,18 x 150	11980	2	16:1	291	396	135		
TD 123	F	D (A)	6	130,175 x 150	12000	2	17,8:1			126		
TD 123 Euro 1	EA, EB	D (A)	6	130,175 x 150	11980	2	17,8:1	224-301	305-409	126		
TD 123 Euro 1	EC, ED	D (LA)	6	130,175 x 150	11980	2	17,8:1	270-301	367-410	126		
TD 123 Euro 1	E, ES	D (A)	6	130,18 x 150	11980	2	17,8:1	262-298	356-405	135		
TD 162	AG, FJ, FS	D (LA)	6	144 x 165	16123	4		217-405	295-551	173		
TD 162	FL	D (A)	6	144 x 165	16123	4	16:1	330-357	450-485	173		
TD 162 Euro 0	F	D (LA)	6	144 x 165	16123	4	15:1	330-357	450-485	173		
TD 163 Euro 1	ES	D (LA)	6	144 x 165	16123	4	17,5:1	368	500	173		
TD 50	A, B	D (A)	6	95,25 x 120	5130	2	17:1	108-121	147-165	61		
TD 60	A, B, BG, C, D, DG	D (A)	6	98,43 x 120	5480	2		70-132	95-180	66		
TD 61	A, ACE, AG, AGP, AP, APB, AW, B, F, FB, G, R	D (LA)	6	98,43 x 120	5480	2		103-153	140-207	66		
TD 61	GA, GB, GC, GE, GS	D (A)	6	98,43 x 120	5480	2	16:1	112-132	152-180	66		
TD 610	G	D (LA)	6	98,43 x 120	5480	2	15:1	103-150	140-204	66		
TD 63 Euro 1	E, ES	D (LA)	6	98,43 x 120	5480	2	18,3:1	132-154	180-210	69		
TD 70	ES, FS, G	D (A)	6	104,77 x 130	6700	2	14,5:1	147-180	200-245	71		
TD 70	GG	D (LA)	6	104,775 x 130	6730	2	14,5:1	100-140	136-190	72		
TD 70	A, B, C, E, F, FC, H, HA	D (A)	6	104,775 x 130		2		136-180	185-245	72		
TD 71	FD, FS, G	D (LA)	6	104,77 x 130		2	15,5:1	178-184	242-250	71		
TD 71	E, F, FA, FC, GE	D (A)	6	104,775 x 130		2	15,5:1	169-180	220-245	72		
TD 71	A, ACE, AG, AGP, AP, APB, AW, FQ, FQK, FSO, FSQ, K	D (LA)	6	104,775 x 130		2	15,5:1	169-184	220-250	72		
TD 720 Euro 1	VE	D (LA)	6	108 x 130	7146	4	18,4:1	122	166	86		
TD 73 Euro 1	E, EA, EB, ES	D (LA)	6	104,775 x 130		2		160-191	215-260	75		
TD520GE Euro 1		D (A)	4	108 x 130	4764	2	17,5-19	78-89	106-121	84		
TD520VE Euro 1		D (A)	4	108 x 130	4764	2	18,4-19	81	110	84		
TD720GE Euro 1		D (A)	6	108 x 130	7145	2	17,5:1	117-134	159-182	84		
TD720VE-PP Euro 1		D (A)	6	108 x 130	7145	2	18,4:1	115	156	84		
THD 100		D (A)	6	120,65 x 140	9600	2	15:1			104		
THD 100	DA, DB, DC	D (LA)	6	120,65 x 140	9600	2	15:1	133-203	181-276	108		
THD 100	A, EA, EE, EK	D (A)	6	120,65 x 140	9600	2		133-212	180-288	105		
THD 100	D, DD	D (A)	6	120,65 x 140	9600	2	15:1	155-203	211-276	108		
THD 100	EB, EC	D (A)	6	120,65 x 140	9600	2	15:1	160-203	218-276	106		
THD 100	E, ED	D (LA)	6	120,65 x 140	9600	2	15:1	160-203	218-276	106		
THD 101	G, GB, GC, GD	D (A)	6	120,65 x 140	9600	2	15:1	160-234	218-318	104		
THD 101	B	D (A)	6	120,65 x 140	9600	2	15/17:1	169-191	230-260	105		
THD 101	K, KB, KC	D (LA)	6	120,65 x 140	9600	2	15:1	203-228	276-310	104		
THD 101	KE, MC	D (LA)	6	120,65 x 140	9600	2	15:1	228-235	310-320	105		
THD 102	KA, KE, KF, KJ	D (LA)	6	120,65 x 140	9600	2	16:1	158-235	215-320	109		
THD 102 Euro 1	KB	D (LA)	6	120,65 x 140	9600	2	16:1	210	286	111		
THD 102	KD	D (LA)	6	120,65 x 140	9600	2	16:1	252	343	111		
THD 103 Euro 1	KB, KD, KF	D (A)	6	120,65 x 140	9600	2		180-250	245-340	109		
THD 103 Euro 2	E, ES	D (LA)	6	120,65 x 140	9600	2	18:1	235	320	109		
TID 120	FG	D (LA)	6	130,175 x 150	12000	2	13,3:1	217-264	295-359	125		
TID 121	LPB	D (LA)	6	130,175 x 150	12000	2	13,3:1	217-305	295-415	129		
TID 121	KP	D (LA)	6	130,175 x 150	12000	2	13,3:1	217-305	295-415	127		
TID 121	FG, KG, KGP, LG, LGP, LP	D (LA)	6	130,175 x 150	12000	2		217-305	295-415	125		
TID 121	KPB	D (LA)	6	130,175 x 150	12000	2	13,3:1	217-305	295-415	128		
TID 162	AG, AGP, AP, APB	D (LA)	6	144 x 165	16120	2		217-405	295-551	174		
TID 61	A, ACE	D (LA)	6	98,43 x 120	5480	2	15:1	103-150	140-204	68		
TID 70	GG	D (A)	6	104,775 x 130	6730	2	14,5:1	116-154	158-209	73		
TMD 100	A	D (A)	6	120,65 x 140	9600	2	17:1	143-194	195-264	104		
TMD 102	A, C	D (LA)	6	120,65 x 140	9600	2	14,3:1	104-200	141-272	110		
TMD 120	A, B	D (A)	6	130,175 x 150	12000	2	15:1	169-243	230-330	125		
TMD 121	C	D (LA)	6	130,175 x 150	12000	2	14,2:1	164-243	223-330	125		
TMD 122	A	D (LA)	6	130,175 x 150	12000	2	14,2:1	221-235	300-320	127		
TMD 30	A	D (A)	4	92 x 90	3598	2	21:1	66	90	58		
TMD 31	B, D, L-A	D (A)	6	92 x 90	3598	2	16:1	74	100	58		
TMD 40	A, B	D (A)	6	92 x 90	3598	2	21:1	67-100	91-136	58		
TMD 41	A, B, D, L-A	D (A)	6	92 x 90	3598	2		110	150	58		
TMD 70	B, C	D (A)	6	104,775 x 130	6730	2	16:1	110-152	150-207	72		
TWD 1210	V	D (LA)	6	130,17 x 150	12000	2	13,3:1			123		
TWD 1210	P	D (LA)	6	130,175 x 150	12000	2				134		

	Cyl.		cm <sup>3</sup>	Comp. Ratio $\epsilon$	kW	PS	Pos	
TWD 1210 Euro 1 G	D (LA) 6	130,175 x 150	12000	2	13,3:1	160-294	218-400	<b>130</b>
TWD 1211 P	D (LA) 6	130,175 x 150	12000	2				<b>134</b>
TWD 1211 G, V	D (LA) 6	130,175 x 150	12000	2		260-325	354-442	<b>132</b>
TWD 1230 VE	D (LA) 6	130,175 x 150	12000	2				<b>132</b>
TWD 1231 VE	D (LA) 6	130,175 x 150	12000	2		310	422	<b>132</b>
TWD 1620 G	D (LA) 6	144 x 165	16120	2	15:1	217-405	295-551	<b>174</b>
TWD 1630 PP	D (LA) 6	144 x 165	16120	2				<b>174</b>
TWD 610 G	D (LA) 6	98,43 x 120	5480	2	15:1	103-150	140-204	<b>68</b>
TWD 710 G, V	D (LA) 6	105 x 130	6730	2	14,5:1	145-168	197-228	<b>78</b>
TWD 731 ME	D (LA) 6	104,775 x 130	6721	2		175	238	<b>77</b>
TWD 731 Euro 1 VE	D (LA) 6	104,775 x 130	6721	2		175	238	<b>77</b>
TWD1240VE Euro 2	D (LA) 6	131 x 150	12130	4	18,5:1	294-310	400-421	<b>145</b>
TWD1630G	D (LA) 6	144 x 165	16123	4	15:1	350-430	476-585	<b>175</b>
TWD1630P	D (LA) 6	144 x 165	16123	4	15:1	288-383	392-521	<b>175</b>
TWD1630V	D (LA) 6	144 x 165	16123	4	15:1	288-383	392-521	<b>175</b>
TWD1643GE Euro 2	D (LA) 6	144 x 165	16123	4	16,5:1	536-644	729-876	<b>178</b>
TWD1644GE Euro 2	D (LA) 6	144 x 165	16123	4	16,8:1	554-640	753-870	<b>178</b>
TWD1645GE Euro 2	D (LA) 6	144 x 165	16123	4	16,8:1	595-681	809-926	<b>178</b>
TWD1652GE Euro 3	D (LA) 6	144 x 165	16123	4	16,5:1	505-557	687-757	<b>178</b>
TWD1653GE Euro 3	D (LA) 6	144 x 165	16123	4	16,5:1	547-604	744-821	<b>178</b>
TWD1663GE Euro 4	D (LA) 6	144 x 165	16123	4	16,8:1	593-655	806-891	<b>178</b>
TWD1672GE Euro 4	D (LA) 6	144 x 165	16123	4	16,8:1	532-585	723-795	<b>178</b>
TWD1673GE Euro 4	D (LA) 6	144 x 165	16123	4	16,8:1	595-655	809-891	<b>178</b>
TWD1683GE Euro 5	D (LA) 6	144 x 165	16123	4	16,8:1	570-655	775-891	<b>178</b>
TWD740GE	D (LA) 6	107 x 135	7284	2	17,2:1	178-222	242-302	<b>80</b>
TWD740VE Euro 1	D (LA) 6	107 x 135	7284	2		151-203	205-276	<b>82</b>



				Pos					Pos
					2.3	08.1984 → 12.1984	B 23 E	B	62
140 (142, 144)					2.3	01.1985 → 07.1985	B 230 E	B	63
2.0	09.1968 → 12.1971	B 20 E	B	50	2.3	01.1985 → 07.1986	B 230 A	B	63
2.0	01.1969 → 07.1974	B 20 A	B	50	2.3	08.1986 → 07.1987	B 230 F	B	62
2.0	09.1970 → 04.1975	B 20 E	B	50	2.3	08.1986 → 12.1988	B 230 K	B	63
2.0	09.1971 → 08.1972	B 20 A	B	50	2.3 i Cat	08.1986 → 12.1988	B 230 F	B	62
2.0	08.1972 → 08.1973	B 20 A	B	50	2.4 D	09.1981 → 12.1984	D 24	D	6
2.0 S	01.1969 → 09.1972	B 20 B	B	50	2.4 Diesel	01.1979 → 07.1985	D 24	D	6
2.0 S	09.1972 → 08.1975	B 20 F	B	29	2.4 Diesel	08.1987 → 08.1993	D 24	D	6
3.0	01.1968 → 08.1973	B 30 E	B	50	2.7 GLT6	08.1979 → 07.1980	B 27 E	B	49
3.0	01.1968 → 08.1973	B 30 F	B	50	2.8	10.1982 → 09.1984	B 28 E	B	56
140 Estate (145)					240 Kombi (P245)				
2.0 S	01.1969 → 07.1974	B 20 A	B	50	2.0	08.1974 → 07.1975	B 20 A	B	50
2.0 S	08.1972 → 07.1973	B 20 B	B	50	2.0	01.1977 → 01.1982	B 19 A	B	51
2.0 S	08.1972 → 07.1973	B 20 E	B	50	2.0	08.1980 → 12.1984	B 19 A	B	51
2.0 S	08.1972 → 07.1974	B 20 B	B	50	2.0	08.1980 → 12.1984	B 19 K	B	51
2.0 S	09.1973 → 02.1975	B 20 F	B	29	2.0	10.1982 → 08.1984	B 19 ET	B	51
160					2.0	08.1983 → 07.1993	B 200 E	B	51
3.0i	01.1968 → 07.1973	B 30 E	B	50	2.0	08.1984 → 07.1985	B 200 K	B	51
3.0i	01.1968 → 07.1973	B 30 F	B	50	2.0	09.1988 → 12.1993	B 200 F	B	51
164 (164)					2.0 T	08.1983 → 05.1993	B 19 ET	B	51
2.9	08.1972 → 07.1974	B 30 E	B	50	2.1	01.1975 → 07.1975	B 21 A	B	57
2.9 E	08.1968 → 07.1973	B 30 A	B	50	2.1	01.1975 → 07.1979	B 21 E	B	57
3.0	09.1968 → 12.1972	B 30 F	B	50	2.1	08.1975 → 07.1980	B 21 A	B	57
3.0 E	09.1972 → 12.1974	B 30 F	B	50	2.1	01.1977 → 08.1978	B 21 E	B	57
165					2.1	08.1980 → 07.1984	B 21 A	B	57
3.0i	01.1968 → 07.1973	B 30 E	B	50	2.1	08.1980 → 07.1984	B 21 F	B	57
3.0i	01.1968 → 07.1973	B 30 F	B	50	2.1	09.1984 → 12.1985	B 21 FT	B	57
166					2.1 Turbo	08.1980 → 07.1985	B 21 ET	B	57
3.0i	01.1968 → 07.1973	B 30 E	B	50	2.3	01.1981 → 07.1984	B 23 A	B	62
3.0i	01.1968 → 07.1973	B 30 F	B	50	2.3	09.1981 → 12.1982	B 230 F	B	62
1800					2.3	01.1983 → 12.1984	B 23 E	B	62
2.0	01.1968 → 07.1973	B 20 A	B	50	2.3	08.1984 → 12.1984	B 23 E	B	62
2.0	01.1968 → 07.1973	B 20 B	B	50	2.3	01.1985 → 07.1985	B 230 E	B	63
2.0	01.1968 → 07.1973	B 20 E	B	50	2.3	01.1985 → 07.1986	B 230 A	B	63
P-S	1968 → 08.1973	B 30 E	B	50	2.3	08.1986 → 07.1987	B 230 F	B	62
P-S	1968 → 08.1973	B 30 F	B	50	2.3	08.1986 → 12.1988	B 230 K	B	63
240 (P242, P244)					2.3 Cat	08.1991 → 07.1992	B 230 F	B	62
1.8	11.1978 → 07.1988	B 17 A	B	44	2.3 i Cat	08.1986 → 12.1988	B 230 F	B	62
2.0	08.1974 → 07.1976	B 20 A	B	50	2.4 Diesel	04.1979 → 08.1993	D 24	D	6
2.0	09.1974 → 12.1975	B 19 A	B	51	2.4 Diesel	08.1988 → 08.1993	D 24	D	6
2.0	01.1977 → 07.1979	B 19 A	B	51	2.7 GLT6	08.1979 → 07.1980	B 27 E	B	49
2.0	09.1978 → 08.1983	B 19 K	B	51	2.8	10.1980 → 09.1982	B 28 E	B	56
2.0	08.1980 → 08.1983	B 19 A	B	51	2.8	10.1981 → 09.1982	B 28 A	B	56
2.0	10.1982 → 08.1984	B 19 ET	B	51	260 (P262, P264)				
2.0	08.1984 → 07.1985	B 200 K	B	51	2.1	09.1979 → 12.1980	B 21 E	B	57
2.0	08.1984 → 12.1993	B 19 E	B	51	2.4 D	09.1979 → 12.1981	D 24	D	6
2.0	01.1985 → 12.1993	B 200 E	B	51	2.7	01.1975 → 07.1980	B 27 E	B	49
2.0	09.1988 → 12.1993	B 19 E	B	51	2.7	08.1978 → 07.1982	B 27 E	B	49
2.0	09.1988 → 12.1993	B 200 F	B	51	2.7	08.1978 → 07.1982	B 27 F	B	49
2.0i	08.1983 → 07.1984	B 19 K	B	51	2.8	01.1981 → 07.1982	B 28 A	B	56
2.1	01.1975 → 07.1975	B 21 A	B	57	2.8	01.1981 → 07.1982	B 28 E	B	56
2.1	01.1975 → 07.1980	B 21 E	B	57	260 Coupe (P262)				
2.1	09.1975 → 12.1977	B 21 A	B	57	2.7	08.1977 → 07.1978	B 27 E	B	49
2.1	09.1975 → 12.1979	B 21 E	B	57	2.8	09.1979 → 12.1981	B 28 F	B	56
2.1	09.1977 → 12.1978	B 21 A	B	57	260 Estate (P265)				
2.1	08.1979 → 07.1980	B 21 A	B	57	2.4 D	09.1979 → 12.1980	D 24	D	6
2.1	09.1979 → 12.1981	B 21 F	B	57	2.7	07.1975 → 12.1980	B 27 E	B	49
2.1	08.1980 → 07.1984	B 21 A	B	57	2.7	10.1978 → 12.1980	B 27 F	B	49
2.1	09.1980 → 12.1985	B 21 ET	B	57	2.8	01.1981 → 07.1982	B 28 F	B	56
2.1	01.1983 → 12.1984	B 21 A	B	57	340-360 (343, 345)				
2.1	09.1983 → 12.1984	B 21 A	B	57	1.3	01.1989 → 12.1990	B 13	B	2
2.1 Turbo	08.1980 → 07.1984	B 21 ET	B	57	1.4	01.1976 → 07.1983	B 14.4 S	B	5
2.3	01.1979 → 07.1980	B 23 E	B	62	1.4	08.1979 → 07.1983	B 14.3 E	B	5
2.3	08.1980 → 07.1983	B 23 E	B	62	1.4	08.1982 → 08.1985	B 14.3 E	B	5
2.3	08.1980 → 07.1983	B 23 F	B	62	1.4	08.1983 → 07.1986	B 14.4 S	B	5
2.3	01.1981 → 07.1984	B 23 A	B	62	1.4	08.1986 → 12.1988	B 14.4 S	B	5
2.3	09.1981 → 12.1983	B 230 F	B	62	1.4	08.1987 → 07.1988	B 14.4 S	B	5
					1.6 Diesel	08.1984 → 07.1991	D 16	D	8



		Pos			Pos	
2.0	08.1980 → 07.1983	B 19 A B	2.3 (USA)	08.1988 → 07.1995	B 230 F B	62
2.0	08.1980 → 07.1983	B 200 K B	2.5i 24V		B 6254 F B	16
2.0	08.1980 → 07.1984	B 19 A B	2.5i 24V		B 6254 G B	17
2.0	08.1982 → 07.1984	B 19 E B	2.9i 24V		B 6304 F B	35
2.0	08.1982 → 07.1984	B 19 E B	2.9i 24V		B 6304 F2 B	35
2.0	08.1983 → 07.1984	B 19 A B	<b>740 (744)</b>			
2.0	08.1984 → 07.1987	B 200 K B	2.0	12.1983 → 07.1984	B 19 ET B	51
2.0	01.1985 → 07.1986	B 200 E B	2.0	01.1985 → 12.1985	B 200 ET B	51
2.0	08.1986 → 07.1988	B 200 E B	2.0	08.1985 → 07.1992	B 200 G B	52
2.0	08.1986 → 07.1988	B 200 F B	2.0	01.1986 → 08.1990	B 200 ET B	51
2.0	08.1987 → 07.1988	B 200 F B	2.0	01.1987 → 08.1988	B 200 E B	51
2.0	08.1988 → 07.1989	B 200 F B	2.0	09.1988 → 08.1990	B 200 K B	51
<b>340-360 Saloon (344)</b>			2.0	09.1990 → 08.1992	B 200 F B	51
1.3	01.1989 → 12.1990	B 13 B	2.0 GLE	04.1983 → 07.1984	B 19 E B	51
1.4	01.1983 → 12.1986	B 14.3 E B	2.0 GLE	09.1987 → 08.1990	B 204 E B	53
1.4	08.1983 → 07.1986	B 14.4 S B	2.0 Turbo	09.1990 → 08.1991	B 200 FT B	51
1.4	08.1986 → 12.1988	B 14.4 S B	2.3	08.1983 → 07.1984	B 23 E B	62
1.4	08.1987 → 07.1988	B 14.4 S B	2.3	08.1984 → 12.1984	B 23 A B	62
1.6 Diesel	08.1984 → 07.1991	D 16 D	2.3	08.1984 → 07.1986	B 230 A B	63
2.0	08.1982 → 07.1984	B 19 A B	2.3	08.1984 → 12.1992	B 230 FB B	62
2.0	08.1983 → 07.1984	B 19 A B	2.3	10.1984 → 07.1988	B 230 K B	63
2.0	08.1983 → 07.1984	B 19 E B	2.3	01.1985 → 07.1988	B 230 E B	63
2.0	08.1984 → 07.1987	B 200 K B	2.3	01.1985 → 12.1988	B 230 F B	62
2.0	08.1984 → 07.1990	B 200 K B	2.3	09.1985 → 12.1988	B 230 F B	62
2.0	01.1985 → 07.1986	B 200 E B	2.3	08.1987 → 12.1988	B 230 F B	62
2.0	01.1985 → 07.1986	B 200 E B	2.3	01.1988 → 07.1989	B 234 F B	64
2.0	08.1986 → 07.1988	B 200 EA B	2.3	08.1988 → 07.1991	B 234 F B	64
2.0	08.1987 → 07.1988	B 200 EA B	2.3	08.1988 → 08.1992	B 234 F B	64
2.0	08.1988 → 07.1989	B 200 F B	2.3 GLE	08.1984 → 12.1985	B 23 E B	62
<b>343</b>			2.3 Turbo	08.1985 → 12.1988	B 230 ET B	62
1.4	08.1976 → 07.1979	B 14 OE B	2.3 Turbo	01.1987 → 07.1989	B 230 FT B	62
<b>345</b>			2.3 Turbo	08.1989 → 07.1990	B 230 FT B	62
1.4	02.1976 → 07.1979	B 14 OE B	2.3 Turbo	08.1989 → 07.1990	B 230 FT B	62
<b>440</b>			2.3 Turbo	09.1989 → 08.1991	B 230 FT B	62
2.0i	08.1982 → 07.1984	B 19 E B	2.3 Turbo	09.1989 → 08.1991	B 230 GT B	62
2.0i	08.1984 → 07.1989	B 200 KE B	2.4 Diesel	08.1984 → 07.1992	D 24 D	6
<b>440 (445)</b>			2.4 TD	08.1984 → 07.1990	D 24 T D	7
1.7	08.1988 → 07.1989	B 18 F B	2.4 TD	08.1985 → 12.1990	D 24 T D	7
1.7	09.1988 → 08.1989	B 18 EP B	2.4 TD	08.1986 → 10.1988	D 24 TIC D	7
1.7	09.1988 → 12.1996	B 18 EP B	<b>740 Kombi (745)</b>			
1.7 Turbo	08.1988 → 07.1996	B 18 FT B	2.0	08.1985 → 07.1992	B 200 E B	51
1.7 Turbo	01.1991 → 12.1996	B 18 FT B	2.0	08.1985 → 07.1992	B 200 G B	52
1.8	01.1992 → 07.1996	B 18 U B	2.0	01.1987 → 08.1988	B 200 E B	51
1.8	09.1995 → 12.1996	B 18 U B	2.0	09.1988 → 08.1990	B 200 K B	51
2.0	01.1993 → 07.1995	B 20 F B	2.0	08.1989 → 07.1991	B 200 F B	51
2.0	08.1993 → 07.1996	B 20 F B	2.0 16V	09.1987 → 08.1990	B 204 E B	53
<b>460 (464)</b>			2.0 GLE	09.1987 → 08.1990	B 204 E B	53
1.7	08.1989 → 07.1992	B 18 E B	2.0 Turbo	05.1985 → 08.1987	B 200 ET B	51
1.7	08.1989 → 07.1992	B 18 EP B	2.0 Turbo	05.1985 → 08.1987	B 200 ET B	51
1.7 Turbo	08.1989 → 07.1996	B 18 FT B	2.0 Turbo	09.1987 → 08.1990	B 200 ET B	51
1.7 Turbo	01.1991 → 07.1996	B 18 FT B	2.0 Turbo	09.1990 → 08.1991	B 200 FT B	51
1.8	01.1992 → 07.1996	B 18 U B	2.3	08.1985 → 07.1986	B 230 A B	63
2.0	01.1993 → 07.1995	B 20 F B	2.3	08.1985 → 07.1988	B 230 E B	63
2.0	08.1993 → 07.1996	B 20 F B	2.3	08.1985 → 12.1988	B 230 F B	62
<b>480 (482)</b>			2.3	09.1985 → 07.1990	B 230 K B	63
1.7	08.1986 → 07.1988	B 18 E B	2.3	08.1987 → 12.1988	B 230 F B	62
1.7	08.1987 → 07.1989	B 18 F B	2.3	01.1988 → 07.1989	B 234 F B	64
1.7	01.1989 → 07.1989	B 18 E B	2.3	01.1988 → 10.1990	B 230 F B	62
1.7	08.1989 → 07.1996	B 18 EP B	2.3	08.1988 → 07.1990	B 234 F B	64
1.7 Turbo	08.1987 → 07.1996	B 18 FT B	2.3	07.1989 → 08.1992	B 234 F B	64
1.7 Turbo	01.1991 → 07.1996	B 18 FT B	2.3	07.1990 → 12.1992	B 230 FB B	62
2.0	01.1993 → 09.1995	B 20 F B	2.3 GL	08.1984 → 08.1987	B 230 E B	63
<b>66</b>			2.3 GLE	08.1984 → 08.1987	B 23 E B	62
1.1	08.1975 → 08.1978	B 10 E B	2.3 Turbo	08.1985 → 07.1988	B 230 ET B	62
<b>66 (31, 36)</b>			2.3 Turbo	01.1987 → 07.1989	B 230 FT B	62
GL 1.3	08.1975 → 08.1978	B 130 B	2.3 Turbo	08.1989 → 07.1990	B 230 FT B	62
<b>66 Estate (64)</b>			2.3 Turbo	08.1989 → 07.1990	B 230 FT B	62
GL 1.3	10.1975 → 11.1979	B 130 B	2.3 Turbo	08.1989 → 07.1990	B 230 GT B	62
<b>740</b>			2.3 Turbo	09.1989 → 08.1991	B 230 FT B	62

V

					Pos						Pos
2.3 Turbo	09.1989 → 08.1991	B 230 GT	B	62	2.3	08.1990 → 07.1991	B 234 F	B	64		
2.4 Diesel	08.1985 → 07.1988	D 24	D	6	2.3	08.1990 → 12.1994	B 230 FB	B	62		
2.4 TD Interc.	08.1986 → 07.1988	D 24 TIC	D	7	2.3	08.1990 → 12.1994	B 230 G	B	62		
2.4 Turbo-Diesel	09.1985 → 07.1992	D 24 T	D	7	2.3	09.1990 → 09.1993	B 230 FT	B	62		
<b>760 (704, 764)</b>					2.3	09.1990 → 04.1997	B 230 E	B	63		
2.3	01.1984 → 03.1986	B 23 ET	B	62	2.3	05.1991 → 03.1995	B 230 FK	B	62		
2.3	08.1984 → 08.1987	B 230 ET	B	62	2.3	08.1992 → 07.1994	B 230 FD	B	62		
2.3	08.1984 → 08.1987	B 230 K	B	63	2.3 Turbo	08.1990 → 07.1994	B 230 FT	B	62		
2.3	01.1988 → 07.1992	B 230 FT	B	62	2.3 Turbo	08.1991 → 07.1993	B 230 FT+	B	62		
2.3 Turbo	08.1982 → 07.1984	B 23 ET	B	62	2.4 D	08.1990 → 12.1994	D 24	D	6		
2.3 Turbo	01.1985 → 07.1985	B 230 ET	B	62	2.4 TD Intercooler	07.1992 → 12.1994	D 24 TIC	D	7		
2.3 Turbo	09.1987 → 08.1990	B 230 FT	B	62	2.4 Turbo Diesel	08.1990 → 12.1994	D 24 T	D	7		
2.4 D	09.1982 → 12.1984	D 24 T	D	7	2.5i 24V	09.1994 → 07.1997	B 6254 F	B	16		
2.4 D	09.1984 → 12.1985	D 24 T	D	7	2.5i 24V	09.1994 → 07.1997	B 6254 G	B	17		
2.4 TD Interc.	08.1987 → 07.1992	D 24 TIC	D	7	2.9i 24V	08.1990 → 07.1998	B 6304 F2	B	35		
2.4 TDiC	09.1987 → 08.1990	D 24 TIC	D	7	2.9i 24V	09.1990 → 07.1998	B 6304 F	B	35		
2.4 Turbo Diesel	08.1982 → 07.1987	D 24 T	D	7	<b>940 II (944)</b>						
2.4 Turbo Diesel	04.1987 → 07.1992	D 24 T	D	7	2.0	10.1994 → 05.1997	B 204 FT	B	54		
2.8	08.1981 → 07.1986	B 28 E	B	56	2.0	11.1994 → 12.1995	B 200 G	B	52		
2.8	01.1982 → 12.1987	B 28 A	B	56	2.0 Turbo	04.1996 → 10.1998	B 200 FT	B	51		
<b>760 Kombi (704, 765)</b>					2.3	08.1994 → 07.1995	B 230 FD	B	62		
2.3	09.1983 → 12.1990	B 230 FT	B	62	2.3	08.1994 → 10.1998	B 230 FB	B	62		
2.3	08.1984 → 08.1987	B 230 K	B	63	2.3 Turbo	08.1994 → 10.1998	B 230 FT	B	62		
2.3 Turbo	01.1985 → 12.1988	B 230 ET	B	62	2.3 Turbo	01.1995 → 12.1998	B 230 FT	B	62		
2.3 Turbo	09.1987 → 08.1990	B 230 FT	B	62	2.3 ti	01.1995 → 10.1998	B 230 FK	B	62		
2.4 D	01.1982 → 07.1992	D 24	D	6	2.4 TD Interc.	08.1994 → 10.1998	D 24 TIC	D	7		
2.4 D	09.1982 → 12.1985	D 24 T	D	7	<b>940 II Estate (945)</b>						
2.4 TD	04.1983 → 10.1989	D 24 T	D	7	2.0	10.1994 → 05.1997	B 204 FT	B	54		
2.4 TD Interc. (765)	08.1987 → 07.1992	D 24 TIC	D	7	2.0	11.1994 → 12.1995	B 200 G	B	52		
2.4 TDiC	09.1987 → 08.1990	D 24 TIC	D	7	2.0 Turbo	04.1996 → 10.1998	B 200 FT	B	51		
2.8 (765)	05.1986 → 12.1987	B 28 A	B	56	2.3	08.1994 → 07.1995	B 230 FD	B	62		
2.8 (765)	08.1986 → 07.1988	B 28 E	B	56	2.3	08.1994 → 10.1998	B 230 FB	B	62		
<b>780 (782)</b>					2.3 Turbo	08.1994 → 10.1998	B 230 FT	B	62		
2.3	04.1986 → 11.1990	B 230 FT	B	62	2.3 Turbo	08.1995 → 10.1998	B 230 FT	B	62		
2.3	09.1988 → 07.1990	B 230 FT	B	62	2.3 ti	01.1995 → 10.1998	B 230 FK	B	62		
2.4 D	04.1986 → 07.1990	D 24 TIC	D	7	2.4 TD Interc.	08.1994 → 10.1998	D 24 TIC	D	7		
2.8i (USA)	08.1982 → 04.1986	B 28 F	B	56	<b>940 Kombi (945)</b>						
2.8i (USA)	08.1982 → 07.1986	B 28 A	B	56	2.0	09.1990 → 09.1993	B 200 G	B	52		
<b>850 (854)</b>					2.0	01.1992 → 07.1994	B 200 F	B	51		
2.0	08.1994 → 12.1996	B 5202 S	B	18	2.0 GL	09.1990 → 04.1992	B 204 E	B	53		
2.0 Turbo	08.1993 → 12.1996	B 5204 T	B	16	2.0 Turbo	01.1991 → 07.1995	B 200 FT	B	51		
2.0 Turbo	09.1993 → 10.1996	B 5204 T2	B	16	2.3	08.1990 → 07.1991	B 234 F	B	64		
2.3 T5 R	04.1996 → 10.1996	B 5234 T2	B	16	2.3	08.1990 → 12.1994	B 230 FB	B	62		
2.3 T5-R	08.1995 → 12.1996	B 5234 T4	B	19	2.3	09.1990 → 09.1993	B 230 FB	B	62		
2.3 Turbo R	09.1994 → 10.1997	B 5234 T5	B	17	2.3	08.1992 → 07.1994	B 230 FD	B	62		
2.3 Turbo R	06.1995 → 10.1996	B 5234 T5	B	17	2.3 Turbo	08.1990 → 07.1994	B 230 FT	B	62		
2.3i	09.1993 → 08.1996	B 5234 S	B	17	2.3 Turbo	08.1991 → 07.1993	B 230 FT+	B	62		
2.4	01.1992 → 12.1996	B 5254 S	B	34	2.4 D	08.1990 → 07.1995	D 24	D	6		
2.4 GLE	05.1996 → 10.1997	B 5254 T	B	34	2.4 TD	05.1991 → 03.1995	D 24 TIC	D	7		
2.5 TDI	01.1996 → 12.1996	D 5252 T	D	23	2.4 TD Intercooler	08.1990 → 08.1994	D 24 TIC	D	7		
<b>850 Estate (855)</b>					2.4 Turbo Diesel	08.1990 → 07.1994	D 24 T	D	7		
2.0	08.1994 → 12.1996	B 5202 S	B	18	<b>960 (964)</b>						
2.0 Turbo	08.1993 → 12.1996	B 5204 T	B	16	2.0		B 200 E	B	51		
2.0 Turbo	01.1997 → 10.1997	B 5204 T2	B	16	2.0		B 200 EA	B	51		
2.3 T5 R	04.1996 → 10.1996	B 5234 T2	B	16	2.0	08.1990 → 09.1993	B 204 FT	B	54		
2.3 T5-R	08.1995 → 12.1996	B 5234 T4	B	19	2.0	09.1990 → 08.1993	B 204 E	B	53		
2.3 Turbo R	09.1994 → 10.1997	B 5234 T5	B	17	2.0	09.1990 → 09.1993	B 200 F	B	51		
2.3 Turbo R	06.1995 → 10.1997	B 5234 T5	B	17	2.0i Turbo	09.1992 → 08.1997	B 200 FT	B	51		
2.4	09.1992 → 12.1996	B 5254 S	B	34	2.3		B 230 E	B	63		
2.4 AWD	05.1996 → 12.1996	B 5254 T	B	34	2.3 Turbo	09.1990 → 08.1993	B 230 FT	B	62		
2.4 GLE	05.1996 → 10.1997	B 5254 T	B	34	2.3i	09.1992 → 08.1994	B 230 FB	B	62		
2.5 TDI	01.1996 → 12.1996	D 5252 T	D	23	2.3i	09.1992 → 07.1995	B 230 FD	B	62		
<b>940 (944)</b>					2.3i	09.1992 →	B 230 G	B	62		
2.0	09.1990 → 09.1993	B 200 E	B	51	2.3i	09.1994 → 07.1995	B 230 F	B	62		
2.0	09.1990 → 09.1993	B 200 G	B	52	2.3i 16V	09.1990 → 07.1992	B 234 F	B	64		
2.0	09.1990 → 09.1993	B 204 FT	B	54	2.4 TD Interc.	09.1991 → 07.1994	D 24 TIC	D	7		
2.0	01.1992 → 07.1994	B 200 F	B	51	2.5i 24V	09.1994 → 08.1997	B 6254 F	B	16		
2.0 GL	09.1990 → 04.1992	B 204 E	B	53	2.5i 24V	09.1994 → 08.1997	B 6254 G	B	17		
2.0 Turbo	08.1990 → 12.1994	B 200 FT	B	51	2.9	01.1991 → 07.1994	B 6304 F	B	35		

V

		Pos			Pos
2.9 09.1991 → 07.1994	B 6304 F B	35	2.4 D 03.2007 → 06.2013	D 5244 T9 D	26
<b>960 II (964)</b>			2.4 i 03.2006 → 10.2009	B 5244 S4 B	35
2.5 07.1994 → 12.1996	B 6254 S B	16	D3 10.2010 → 06.2013	D 5204 T5 D	25
2.9 07.1994 → 12.1996	B 6304 S B	34	D4 10.2010 → 06.2013	D 5204 T D	25
<b>960 II Estate (965)</b>			D5 03.2006 → 06.2013	D 5244 T13 D	26
2.5 08.1994 → 12.1996	B 6254 S B	16	D5 03.2006 → 06.2013	D 5244 T8 D	24
2.9 09.1994 → 12.1996	B 6304 S B	34	T5 03.2006 → 02.2007	B 5254 T3 B	41
<b>960 Kombi (965)</b>			T5 03.2007 → 06.2013	B 5254 T7 B	40
2.0 08.1990 → 09.1993	B 204 FT B	54	<b>P 121</b>		
2.0 09.1990 → 08.1993	B 204 E B	53	2.0 01.1969 → 05.1971	B 20 A B	50
2.3 Turbo 09.1990 → 08.1993	B 230 FT B	62	<b>P 122 S AMAZON</b>		
2.4 TD Interc. 09.1991 → 07.1994	D 24 TIC D	7	2.0 01.1969 → 12.1970	B 20 A B	50
2.4 Tdi 09.1990 → 08.1993	D 24 TIC D	7	2.0 01.1969 → 05.1971	B 20 B B	50
2.9 08.1990 → 07.1994	B 6304 S B	34	<b>P 1800 (P18)</b>		
2.9 01.1991 → 07.1994	B 6304 F B	35	2.0 09.1969 → 11.1973	B 20 E B	50
<b>AMAZON P 123</b>			2.0 ES 08.1969 → 11.1973	B 20 E B	50
2.0 01.1961 →	B 20 A B	50	<b>S40 I (644)</b>		
2.0 01.1961 →	B 20 B B	50	1.6 09.1995 → 08.1999	B 4164 S B	16
<b>C SERIES</b>			1.6 01.2000 → 12.2003	B 4164 S2 B	16
10 M 01.1981 →	TD 101 KC D	105	1.8 07.1995 → 08.1999	B 4184 S3 B	34
10 M 01.1981 →	THD 101 K D	104	1.8 01.1996 → 08.1999	B 4184 S B	34
10 M 01.1981 →	THD 101 KB D	104	1.8 03.1999 → 12.2003	B 4184 S2 B	34
10 M 01.1981 →	THD 101 MC D	105	1.8 06.2001 → 08.2003	B 4184 S2 B	34
10 M 10.1984 → 12.1985	THD 101 KC D	104	1.8 LPG 03.1999 → 12.2004	B 4184 S9 BG	32
10 M 10.1984 → 12.1987	THD 101 GD D	104	1.8 i 03.1998 → 12.2003	B 4184 SM B	16
306 10.1974 → 11.1991	B 30 A B	50	1.8 i 06.2001 → 12.2003	B 4184 SJ B	16
<b>C30 (533)</b>			1.9 DI 01.2000 → 07.2000	D 4192 T2 D	13
1.6 10.2006 → 12.2012	B 4164 S3 B	9	1.9 DI 07.2000 → 12.2003	D 4192 T3 D	13
1.6 D 10.2006 → 12.2012	D 4164 T D	3	1.9 DI 07.2000 → 12.2003	D 4192 T4 D	13
1.6 D2 10.2010 → 12.2012	D 4162 T D	4	1.9 T4 05.1997 → 07.2000	B 4194 T B	17
1.8 10.2006 → 12.2012	B 4184 S11 B	42	1.9 T4 05.1997 → 07.2000	B 4194 T2 B	17
1.8 FlexFuel 01.2007 → 12.2012	B 4184 S8 AB	43	1.9 TD 09.1996 → 08.1999	D 4192 T D	12
2.0 10.2006 → 12.2012	B 4204 S3 B	46	2.0 07.1995 → 08.1999	B 4204 S B	34
2.0 D 10.2006 → 12.2012	D 4204 T D	45	2.0 07.1995 → 12.2003	B 4204 S B	34
2.0 FlexFuel 01.2010 → 12.2012	B 4204 S4 AB	48	2.0 07.1995 → 12.2003	B 4204 S2 B	35
2.4 i 10.2006 → 12.2012	B 5244 S4 B	35	2.0 D 12.2002 → 06.2004	D 4204 T D	45
D3 10.2010 → 12.2012	D 5204 T5 D	25	2.0 T 10.1997 → 12.2003	B 4204 T B	34
D4 10.2010 → 12.2012	D 5204 T D	25	2.0 T 07.2000 → 06.2001	B 4204 T2 B	34
D5 10.2006 → 12.2012	D 5244 T13 D	26	2.0 T 07.2000 → 06.2001	B 4204 T3 B	34
D5 10.2006 → 12.2012	D 5244 T8 D	24	2.0 T 06.2001 → 12.2003	B 4204 T3 B	34
D5 10.2006 → 12.2012	D 5244 T9 D	26	2.0 T4 07.2000 → 12.2003	B 4204 T5 B	38
T5 10.2006 → 12.2012	B 5254 T3 B	41	2.0i 20V 01.1996 →	B 5204 S B	17
T5 03.2007 → 12.2012	B 5254 T7 B	40	2.5i Turbo 20V 12.2003 → 05.2007	B 5254 T3 B	41
T5 10.2007 → 12.2013	B 5254 T7 B	40	2.5i Turbo 20V 04.2007 →	B 5254 T7 B	40
<b>C70</b>			<b>S40 II (544)</b>		
2.4 TDI 20V 03.2006 →	D 5244 T8 D	24	1.6 01.2005 → 12.2012	B 4164 S3 B	9
<b>C70 I Convertible (873)</b>			1.6 D 01.2005 → 12.2012	D 4164 T D	3
2.0 03.1998 → 10.2005	B 5204 T2 B	16	1.6 D2 10.2010 → 12.2012	D 4162 T D	4
2.0 T 03.1998 → 10.2005	B 5204 T3 B	16	1.8 04.2004 → 12.2010	B 4184 S11 B	42
2.0 T 03.2000 → 10.2005	B 5204 T4 B	16	1.8 FlexFuel 01.2006 → 12.2010	B 4184 S8 AB	43
2.3 09.2002 → 12.2003	B 5234 T3 B	16	2.0 10.2006 → 12.2012	B 4204 S3 B	46
2.3 T5 03.1998 → 10.2005	B 5234 T3 B	16	2.0 CDI 07.2005 → 12.2006	D 4204 T2 D	45
2.3 T5 07.2002 → 10.2005	B 5234 T9 B	17	2.0 D 01.2004 → 12.2010	D 4204 T D	45
2.4 06.1998 → 10.2005	B 5254 S B	34	2.0 D4 07.2005 → 12.2006	D 4204 T2 D	45
2.4 T 03.1998 → 10.2005	B 5244 T B	36	2.0 F 10.2009 → 12.2012	B 4204 S4 AB	48
2.4 T 03.1998 → 10.2005	B 5254 T B	34	2.4 01.2004 → 12.2010	B 5244 S5 B	35
<b>C70 I Coupe (872)</b>			2.4 01.2004 → 12.2012	B 5244 S4 B	35
2.0 03.1997 → 09.2002	B 5204 T2 B	16	2.4 CDI 03.2007 → 12.2010	D 5244 T9 D	26
2.0 T 03.1997 → 09.2002	B 5204 T3 B	16	2.4 D5 03.2006 → 12.2010	D 5244 T13 D	26
2.0 T 03.2000 → 09.2002	B 5204 T4 B	16	2.4 D5 03.2006 → 12.2010	D 5244 T8 D	24
2.3 T-5 03.1997 → 09.2002	B 5234 T3 B	16	D3 10.2010 → 12.2012	D 5204 T5 D	25
2.4 03.1999 → 09.2002	B 5254 S B	34	D4 10.2010 → 12.2012	D 5204 T D	25
2.4 05.1999 → 09.2002	B 5244 S B	34	T5 01.2004 → 12.2007	B 5254 T3 B	41
2.4 11.1999 → 09.2002	B 5254 S B	34	T5 03.2007 → 12.2012	B 5254 T7 B	40
2.4 T 03.1997 → 09.2002	B 5244 T B	36	T5 AWD 04.2004 → 12.2007	B 5254 T3 B	41
2.4 T 03.1997 → 09.2002	B 5254 T B	34	T5 AWD 03.2007 → 12.2010	B 5254 T7 B	40
<b>C70 II Convertible (542)</b>			<b>S60 I (384)</b>		
2.0 D 01.2008 → 10.2009	D 4204 T D	45	2.0 T 07.2000 → 04.2010	B 5204 T5 B	21
2.4 03.2006 → 10.2009	B 5244 S5 B	35	2.3 T5 07.2000 → 09.2002	B 5234 T7 B	16

V



				Pos					Pos
2.3 T5	09.2000 → 12.2004	B 5234 T3	B	16	2.0	01.1997 → 11.2000	B 5204 T2	B	16
2.4	07.2000 → 04.2010	B 5244 S2	B	35	2.0	01.1997 → 11.2000	B 5204 T4	B	16
2.4	11.2000 → 04.2010	B 5244 S	B	34	2.0 Turbo	01.1997 → 11.2000	B 5204 T	B	16
2.4 Bifuel (CNG)	07.2001 → 04.2010	B 5244 SG	BG	33	2.0 Turbo	01.1997 → 11.2000	B 5204 T3	B	16
2.4 Bifuel (LPG)	07.2001 → 04.2010	B 5244 SG2	BG	33	2.0i 20V	01.1997 → 07.1998	B 5204 S	B	17
2.4 CDI	10.2003 → 12.2005	D 5244 T3	D	25	2.3	11.1996 → 11.2000	B 5234 T3	B	16
2.4 D	05.2001 → 04.2010	D 5244 T2	D	24	2.3	04.1999 → 09.2000	B 5234 T7	B	16
2.4 D	03.2005 → 04.2010	D 5244 T7	D	26	2.3 T-5	01.1997 → 11.2000	B 5234 T3	B	16
2.4 D	05.2005 → 12.2006	D 5244 T6	D	26	2.3 T5 AWD	11.1996 → 09.1998	B 5234 T3	B	16
2.4 D	07.2005 → 12.2009	D 5244 T5	D	24	2.3 T5 AWD	07.1997 → 09.2000	B 5234 T4	B	19
2.4 D5	01.2001 → 04.2010	D 5244 T	D	24	2.3 Turbo	01.1997 → 11.2000	B 5234 T4	B	19
2.4 D5	03.2005 → 04.2010	D 5244 T4	D	24	2.3i	01.1997 → 07.1999	B 5234 S	B	17
2.5 T	01.2003 → 04.2010	B 5254 T2	B	39	2.4	01.1997 → 11.2000	B 5244 S	B	34
2.5 T AWD	07.2002 → 04.2010	B 5254 T2	B	39	2.4	01.1997 → 11.2000	B 5254 S	B	34
2.5 TDi	07.2000 →	D 5252 T	D	23	2.4	06.1998 → 11.2000	B 5254 S	B	34
R 2,5 T AWD	01.2003 → 04.2010	B 5254 T4	B	40	2.4	08.1999 → 11.2000	B 5244 S2	B	35
T5	07.2000 → 04.2010	B 5234 T3	B	16	2.4	08.1999 → 11.2000	B 5244 SG	BG	33
<b>S60 II (134)</b>					2.4 AWD	10.1998 → 05.1999	B 5254 S	B	34
2.0 D2	03.2015 → 05.2018	D 4204 T20	D	28	2.4 AWD	04.1999 → 09.2000	B 5244 S	B	34
2.0 D2	03.2015 → 05.2018	D 4204 T8	D	28	2.4 AWD	04.1999 → 09.2000	B 5244 S2	B	35
2.0 D3	03.2015 → 05.2018	D 4204 T4	D	28	2.4 Bifuel	07.1999 → 11.2000	B 5244 SG	BG	33
2.0 D3	03.2015 → 05.2018	D 4204 T9	D	28	2.4 Blu-Fuel	07.1997 → 09.2000	B 5244 S2	B	35
2.0 D4	03.2015 → 05.2018	D 4204 T14	D	28	2.4 Blu-Fuel	08.1999 → 09.2000	B 5244 SG	BG	33
2.0 D5	03.2015 → 05.2018	D 4204 T11	D	28	2.4 T5 AWD	11.1996 → 04.1999	B 5254 T	B	34
2.0 T	04.2010 → 12.2011	B 4204 T6	B	47	2.4 Turbo	01.1997 → 11.2000	B 5244 T	B	36
2.0 T	05.2012 → 12.2015	B 5204 T8	B	22	2.4 Turbo	01.1997 → 11.2000	B 5254 T	B	34
2.0 T3	03.2015 → 05.2018	B 4204 T37	B	27	2.5 TDi	01.1997 → 11.2000	D 5252 T	D	23
2.0 T4	03.2015 → 05.2018	B 4204 T19	B	27	2.5 TDi AWD	10.1999 → 09.2000	D 5252 T	D	23
2.0 T5 DRIVe	09.2014 → 12.2015	B 4204 T7	B	47	<b>S80 I (184)</b>				
2.0 T5 Flexfuel	09.2014 → 05.2018	B 4204 T15	B	27	2.0	06.1998 → 07.2006	B 5204 T4	B	16
2.4 D4 AWD	03.2015 → 05.2018	D 5244 T21	D	25	2.0 T	06.1998 → 07.2006	B 5204 T3	B	16
2.5 T	01.2013 → 01.2016	B 5254 T14	B	41	2.0 T	12.1999 → 07.2006	B 5204 T5	B	21
2.5 T5 AWD	03.2015 → 12.2018	B 5254 T14	B	41	2.3 R	04.2000 → 08.2005	B 5234 T7	B	16
D3	04.2010 → 12.2014	D 5204 T2	D	25	2.3i Turbo 20V		B 5234 T7	B	16
D3	04.2010 → 12.2014	D 5204 T3	D	25	2.4	01.1999 → 07.2006	B 5244 S	B	34
D3	05.2012 → 12.2015	D 5204 T7	D	25	2.4	01.1999 → 07.2006	B 5244 S2	B	35
D4	04.2010 → 12.2014	D 5204 T3	D	25	2.4 Bifuel (CNG)	09.2001 → 07.2006	B 5244 SG2	BG	33
D4	09.2013 → 12.2015	D 4204 T5	D	28	2.4 Bifuel (LPG)	09.2001 → 07.2006	B 5244 SG	BG	33
D4 Drive-E Polestar	03.2015 → 05.2018	D 4204 T14	D	28	2.4 D	10.2001 → 07.2006	D 5244 T2	D	24
D4 Polestar AWD	03.2015 → 07.2018	D 5244 T21	D	25	2.4 D5	08.2001 → 07.2006	D 5244 T	D	24
D5	04.2010 → 12.2011	D 5244 T10	D	26	2.4F 20V (CNG)	01.2001 → 09.2005	B 5244 SG	BG	33
D5	04.2011 → 12.2015	D 5244 T11	D	25	2.5 T	03.2003 → 07.2006	B 5254 T2	B	39
D5	04.2011 → 12.2015	D 5244 T15	D	25	2.5 T AWD	07.2003 → 07.2006	B 5254 T2	B	39
D5	04.2014 → 12.2015	D 5244 T15	D	25	2.5 TDi	01.1999 → 07.2006	D 5252 T	D	23
D5 AWD	04.2010 → 12.2011	D 5244 T10	D	26	2.8 T6	05.1998 → 12.2001	B 6284 T	B	20
D5 AWD	04.2011 → 12.2015	D 5244 T15	D	25	2.9	05.1998 → 07.2006	B 6304 S3	B	34
D5 AWD	04.2014 → 12.2015	D 5244 T15	D	25	2.9	05.1998 → 02.2008	B 6294 S2	B	37
D5 Drive-E Polestar	03.2015 → 05.2018	D 4204 T11	D	28	2.9	03.1999 → 07.2006	B 6294 S	B	37
DRIVe / D2	01.2011 → 12.2015	D 4162 T	D	4	2.9 T6	06.2001 → 07.2006	B 6294 T	B	37
T4F	04.2011 → 12.2015	B 4164 T2	AB	11	3.0	06.2001 → 07.2006	B 6294 S2	B	37
T5	04.2010 → 12.2014	B 4204 T7	B	47	3.0 T6	06.2001 → 07.2006	B 6294 T	B	37
T5	01.2013 → 12.2016	B 5254 T12	B	41	<b>S80 II (124)</b>				
T5	09.2013 → 12.2018	B 4204 T11	B	27	1.6 D DRIVe	01.2010 → 12.2011	D 4164 T	D	3
T5	11.2013 → 03.2015	B 5204 T9	B	22	1.6 D2	01.2014 → 12.2016	D 4162 T	D	4
T5 AWD	07.2014 → 12.2018	B 4204 T11	B	27	1.6 DRIVe	06.2011 → 01.2014	D 4162 T	D	4
T5 AWD	08.2015 → 12.2018	B 5254 T12	B	41	2.0	01.2008 → 09.2012	B 4204 S3	B	46
T5 Drive-E Polestar AWD	06.2016 → 05.2018	B 4204 T11	B	27	2.0 Drive- E	12.2014 → 12.2016	B 4204 T11	B	27
<b>S60 III (224)</b>					2.0 FlexFuel	01.2008 → 12.2011	B 4204 S4	AB	48
T4	02.2019 →	B 4204 T31	B	27	2.0 T	01.2010 → 05.2011	B 4204 T6	B	47
T4	02.2019 →	B 4204 T44	B	27	2.0 T5	01.2014 → 12.2016	B 4204 T15	B	27
T5	02.2019 →	B 4204 T26	B	27	2.0 TDi	02.2008 → 03.2011	D 4204 T	D	45
T5 AWD	02.2019 →	B 4204 T26	B	27	2.4 D	03.2006 → 06.2009	D 5244 T5	D	24
T5 AWD	05.2019 →	B 4204 T20	B	27	2.4 D	07.2009 → 03.2011	D 5244 T19	D	25
T5 AWD	05.2019 →	B 4204 T23	B	27	2.4 D	01.2010 → 03.2011	D 5244 T14	D	25
T5 AWD	05.2019 →	B 4204 T23	B	27	2.5 T	03.2006 → 12.2011	B 5254 T6	B	40
T5 Polestar AWD	07.2019 →	B 4204 T23	B	27	2.5 T	01.2010 → 12.2012	B 5254 T10	B	41
<b>S70 (874)</b>					2.5 T	01.2012 → 04.2016	B 5254 T12	B	41
2.0	01.1997 → 11.2000	B 5202 S	B	18	2.5 T	09.2012 → 12.2016	B 5254 T14	B	41
					2.5 T AWD	10.2006 → 04.2009	B 5254 T6	B	40



		Pos			Pos					
D3	05.2012 → 05.2014	D 5204 T7	D	25	D4 Polestar	05.2014 →	D 4204 T14	D	28	
D3 / D4	01.2010 → 12.2016	D 5204 T2	D	25	T2	02.2015 →	B 4204 T17	B	27	
D3 / D4	01.2010 → 12.2016	D 5204 T3	D	25	T2	02.2015 →	B 4204 T38	B	27	
D4	09.2013 → 12.2016	D 4204 T5	D	28	T2 GTDi	03.2013 → 12.2015	B 4164 T4	B	10	
D5	03.2006 → 08.2009	D 5244 T4	D	24	T3	02.2015 → 08.2018	B 4204 T37	B	27	
D5	01.2010 → 12.2011	D 5244 T10	D	26	T4	07.2013 → 12.2015	B 5204 T8	B	22	
D5	06.2011 → 04.2015	D 5244 T11	D	25	T4	08.2015 →	B 4204 T19	B	27	
D5	06.2011 → 04.2015	D 5244 T15	D	25	T4 AWD	07.2013 →	B 5204 T8	B	22	
D5 AWD	01.2007 → 05.2009	D 5244 T4	D	24	T4 AWD	05.2014 →	B 4204 T21	B	27	
D5 AWD	01.2010 → 12.2011	D 5244 T10	D	26	T5	12.2012 →	B 5254 T12	B	41	
D5 AWD	06.2011 → 04.2015	D 5244 T15	D	25	T5	03.2013 → 12.2015	B 5204 T9	B	22	
T4F	05.2011 → 01.2014	B 4164 T2	AB	11	T5	01.2014 →	B 5254 T14	B	41	
T5	10.2010 → 12.2016	B 4204 T7	B	47	T5	05.2014 →	B 4204 T11	B	27	
T5	09.2013 → 05.2014	B 4204 T11	B	27	T5	01.2015 →	B 5204 T9	B	22	
<b>S90 II (234)</b>						T5 AWD	01.2013 →	B 5254 T12	B	41
2.0	03.2016 →	B 4204 T20	B	27	T5 AWD	03.2013 →	B 5204 T9	B	22	
2.0 B5 Mild-Hybrid	03.2020 →	B 4204 T26	B	27	T5 AWD	03.2014 → 12.2015	B 5204 T9	B	22	
2.0 D3	03.2016 → 08.2018	D 4204 T16	D	28	T5 AWD	05.2014 →	B 4204 T11	B	27	
2.0 D3	03.2016 → 08.2018	D 4204 T9	D	28	T5 Drive-E Polestar	05.2014 →	B 4204 T11	B	27	
2.0 D4	03.2016 →	D 4204 T14	D	28	T5 Polestar AWD	01.2015 →	B 4204 T11	B	27	
2.0 D4	09.2018 →	D 4204 T7	D	28	<b>V40 II CROSS COUNTRY</b>					
2.0 D4 AWD	03.2016 →	D 4204 T14	D	28	D2 1.6	01.2013 →	D 4162 T	D	4	
2.0 D5 AWD	03.2016 →	D 4204 T23	D	28	<b>V40 Kombi (645)</b>					
2.0 D5 Polestar AWD	06.2019 →	D 4204 T23	D	28	2.0i 20V	01.1996 →	B 5204 S	B	17	
2.0 T4	10.2017 →	B 4204 T31	B	27	<b>V50 (545)</b>					
2.0 T4 Polestar	06.2019 →	B 4204 T31	B	27	1.6	01.2005 → 12.2012	B 4164 S3	B	9	
2.0 T5	03.2016 →	B 4204 T23	B	27	1.6 D	01.2005 → 12.2011	D 4164 T	D	3	
2.0 T5	10.2017 →	B 4204 T26	B	27	1.6 D	03.2005 → 12.2012	D 4164 T	D	3	
2.0 T5 AWD	01.2018 →	B 4204 T23	B	27	1.6 D2	01.2010 → 12.2012	D 4162 T	D	4	
2.0 T5 Drive-E Polestar	03.2016 →	B 4204 T23	B	27	1.8	04.2004 → 12.2010	B 4184 S11	B	42	
2.0 T5 Drive-E Polestar	10.2017 →	B 4204 T26	B	27	1.8 BiFuel	01.2009 → 09.2010	B 4184 S8	AB	43	
D4 Drive-E Polestar	03.2016 →	D 4204 T14	D	28	1.8 FlexFuel	01.2005 → 12.2010	B 4184 S8	AB	43	
D4 Drive-E Polestar AWD	03.2016 →	D 4204 T14	D	28	2.0	10.2006 → 12.2012	B 4204 S3	B	46	
<b>V40 Estate (645)</b>						2.0 CDI	12.2003 → 12.2006	D 4204 T2	D	45
1.6	12.1995 → 08.1999	B 4164 S	B	16	2.0 D	04.2004 → 12.2010	D 4204 T	D	45	
1.6	01.2000 → 06.2004	B 4164 S2	B	16	2.0 D4	07.2005 → 12.2006	D 4204 T2	D	45	
1.8	07.1995 → 08.1999	B 4184 S3	B	34	2.0 FlexFuel	01.2010 → 12.2012	B 4204 S4	AB	48	
1.8	01.1996 → 08.1999	B 4184 S	B	34	2.4	04.2004 → 12.2010	B 5244 S4	B	35	
1.8	03.1999 → 06.2004	B 4184 S2	B	34	2.4	04.2004 → 12.2010	B 5244 S5	B	35	
1.8 Bi-Fuel	11.1999 → 08.2003	B 4184 S9	BG	32	2.4 AWD	08.2006 → 12.2009	B 5244 S4	B	35	
1.8 Blu-Fuel	06.2001 → 08.2003	B 4184 S2	B	34	2.4 D5	03.2006 → 12.2010	D 5244 T13	D	26	
1.8 LPG	03.1999 → 06.2004	B 4184 S9	BG	32	2.4 D5	03.2006 → 12.2010	D 5244 T8	D	24	
1.8 i	03.1998 → 06.2004	B 4184 SM	B	16	2.4 TDI 20V	03.2006 →	D 5244 T8	D	24	
1.8 i	06.2001 → 06.2004	B 4184 SJ	B	16	2.4 TDI 20V	05.2007 →	D 5244 T9	D	26	
1.9 DI	01.2000 → 07.2000	D 4192 T2	D	13	2.4 Tdi	05.2007 → 12.2010	D 5244 T9	D	26	
1.9 DI	07.2000 → 06.2004	D 4192 T3	D	13	D3	10.2010 → 12.2012	D 5204 T5	D	25	
1.9 DI	07.2000 → 06.2004	D 4192 T4	D	13	D4	10.2010 → 12.2012	D 5204 T	D	25	
1.9 T4	05.1997 → 07.2000	B 4194 T	B	17	T5	04.2004 → 12.2007	B 5254 T3	B	41	
1.9 T4	05.1997 → 07.2000	B 4194 T2	B	17	T5	03.2007 → 12.2012	B 5254 T7	B	40	
1.9 TD	09.1996 → 08.1999	D 4192 T	D	12	T5 AWD	04.2004 → 12.2007	B 5254 T3	B	41	
2.0	07.1995 → 08.1999	B 4204 S	B	34	T5 AWD	03.2007 → 12.2010	B 5254 T7	B	40	
2.0	07.1995 → 06.2004	B 4204 S	B	34	<b>V60 I (155, 157)</b>					
2.0	07.1995 → 06.2004	B 4204 S2	B	35	1.6 DRIVe	02.2011 → 12.2015	D 4162 T	D	4	
2.0	09.1999 → 12.2000	B 4204 T	B	34	2.0 BiFuel	03.2014 → 12.2015	B 5204 T9	B	22	
2.0	09.1999 → 12.2000	B 4204 T2	B	34	2.0 D2	03.2015 → 05.2018	D 4204 T20	D	28	
2.0 D	12.2002 → 06.2004	D 4204 T	D	45	2.0 D2	03.2015 → 05.2018	D 4204 T8	D	28	
2.0 T	10.1997 → 07.2000	B 4204 T	B	34	2.0 D3	03.2015 → 05.2018	D 4204 T4	D	28	
2.0 T	07.1999 → 06.2004	B 4204 T2	B	34	2.0 D3	03.2015 → 05.2018	D 4204 T9	D	28	
2.0 T	06.2001 → 06.2004	B 4204 T3	B	34	2.0 D4	03.2015 → 05.2018	D 4204 T14	D	28	
2.0 T4	07.2000 → 06.2004	B 4204 T5	B	38	2.0 D4 Drive-E Polestar	03.2015 → 05.2018	D 4204 T14	D	28	
<b>V40 Hatchback (525, 526)</b>						2.0 T	07.2010 → 12.2012	B 4204 T6	B	47
D2	03.2012 →	D 4162 T	D	4	2.0 T	01.2014 → 07.2018	B 5204 T8	B	22	
D2	02.2015 → 08.2018	D 4204 T8	D	28	2.0 T4	03.2015 → 05.2018	B 4204 T19	B	27	
D3	03.2012 → 03.2015	D 5204 T6	D	25	2.0 T5	01.2014 → 12.2017	B 4204 T15	B	27	
D3	04.2015 →	D 4204 T16	D	28	2.4 D5	04.2011 → 12.2015	D 5244 T11	D	25	
D3	04.2015 →	D 4204 T9	D	28	2.4 D5	04.2011 → 12.2015	D 5244 T15	D	25	
D4	03.2012 →	D 5204 T4	D	25	2.4 D5 AWD	04.2011 → 12.2015	D 5244 T15	D	25	
D4	05.2014 →	D 4204 T14	D	28	D3	05.2012 → 12.2015	D 5204 T7	D	25	
					D3 / D4	07.2010 → 12.2014	D 5204 T2	D	25	

V







				Pos					Pos
D3 / D4	07.2010 → 12.2014	D 5204 T3	D	25	2.4 Turbo AWD	01.1997 → 12.2000	B 5254 T	B	34
D4	10.2013 → 12.2015	D 4204 T5	D	28	2.5 TDI	01.1997 → 12.2000	D 5252 T	D	23
D4 AWD	05.2012 → 12.2015	D 5244 T17	D	25	2.5 TDi AWD	11.1996 → 02.2000	D 5252 T	D	23
D4 AWD	10.2013 → 12.2015	D 5244 T12	D	25	<b>V70 II (285)</b>				
D4 AWD	03.2015 → 05.2018	D 5244 T21	D	25	2.0 T	11.1999 → 08.2007	B 5204 T5	B	21
D4 Polestar AWD	03.2015 → 05.2018	D 5244 T21	D	25	2.3	10.2000 → 09.2004	B 5234 T7	B	16
D4 Polestar AWD	03.2015 → 05.2018	D 5244 T21	D	25	2.3	03.2002 → 12.2004	B 5234 T3	B	16
D5	07.2010 → 12.2011	D 5244 T10	D	26	2.3 AWD	10.2000 → 09.2004	B 5234 T7	B	16
D5	04.2014 → 12.2015	D 5244 T23	D	25	2.3 AWD	10.2000 → 09.2004	B 5234 T8	B	17
D5	03.2015 → 05.2018	D 4204 T11	D	28	2.3 T5	11.1999 → 12.2004	B 5234 T3	B	16
D5 AWD	07.2010 → 12.2011	D 5244 T10	D	26	2.4	03.2000 → 09.2003	B 5254 S	B	34
D5 AWD	04.2014 → 12.2015	D 5244 T15	D	25	2.4	03.2000 → 08.2007	B 5244 S	B	34
T3	03.2015 → 05.2018	B 4204 T37	B	27	2.4	03.2000 → 08.2007	B 5244 S2	B	35
T4F	04.2011 → 12.2015	B 4164 T2	AB	11	2.4 AWD	03.2000 → 09.2003	B 5254 S	B	34
T5	09.2010 → 12.2014	B 4204 T7	B	47	2.4 Bifuel (CNG)	09.2001 → 08.2007	B 5244 SG	BG	33
T5	08.2012 → 07.2014	B 4204 T7	B	47	2.4 Bifuel (LPG)	09.2001 → 08.2007	B 5244 SG2	BG	33
T5	10.2013 → 05.2018	B 5204 T9	B	22	2.4 CDI	07.2005 → 12.2008	D 5244 T6	D	26
T5	10.2013 → 12.2018	B 4204 T11	B	27	2.4 D	07.2001 → 08.2007	D 5244 T2	D	24
T5 AWD	07.2014 → 05.2018	B 4204 T11	B	27	2.4 D	04.2005 → 12.2008	D 5244 T7	D	26
T5 AWD	03.2015 → 05.2018	B 5254 T14	B	41	2.4 D5	01.2001 → 12.2008	D 5244 T	D	24
T5 AWD	04.2015 → 05.2018	B 5254 T12	B	41	2.4 D5	01.2001 → 12.2008	D 5244 T2	D	24
T5 Drive-E Polestar	03.2015 → 07.2018	B 4204 T11	B	27	2.4 D5	01.2001 → 12.2008	D 5244 T5	D	24
T5 Drive-E Polestar	03.2015 → 07.2018	B 4204 T11	B	27	2.4 D5	04.2005 → 12.2008	D 5244 T4	D	24
AWD					2.4 D5 AWD	07.2002 → 08.2007	D 5244 T	D	24
<b>V60 II (225, 227)</b>					2.4 D5 AWD	07.2002 → 08.2007	D 5244 T2	D	24
2.0 T4	05.2019 →	B 4204 T31	B	27	2.4 D5 AWD	07.2002 → 08.2007	D 5244 T5	D	24
D3	02.2018 →	D 4204 T16	D	28	2.4 D5 AWD	05.2005 → 08.2007	D 5244 T4	D	24
D3 AWD	09.2018 →	D 4204 T4	D	28	2.4 T	09.2000 → 12.2002	B 5244 T	B	36
D4	02.2018 →	D 4204 T14	D	28	2.4 T AWD	09.2000 → 12.2002	B 5244 T	B	36
D4 AWD	09.2018 →	D 4204 T14	D	28	2.5	09.2003 → 08.2007	B 5254 T2	B	39
D4 Polestar	02.2018 →	D 4204 T14	D	28	2.5 AWD	09.2002 → 12.2004	B 5254 T2	B	39
D4 Polestar AWD	02.2018 → 12.2020	D 4204 T14	D	28	2.5 T	07.2001 → 08.2007	B 5254 T2	B	39
T5	02.2018 →	B 4204 T26	B	27	2.5 T AWD	07.2002 → 08.2007	B 5254 T2	B	39
T5	08.2019 →	B 4204 T23	B	27	2.5 TDI	03.2000 → 08.2007	D 5252 T	D	23
T5	05.2020 →	B 4204 T23	B	27	R 2,5 T AWD	03.2003 → 08.2007	B 5254 T4	B	40
T5 AWD	03.2019 →	B 4204 T26	B	27	<b>V70 III (135)</b>				
T5 AWD	05.2019 →	B 4204 T23	B	27	1.6 D	07.2009 → 12.2011	D 4164 T	D	3
T5 Polestar	07.2019 →	B 4204 T11	B	27	1.6 DRIVE / D2	04.2011 → 12.2015	D 4162 T	D	4
T5 Polestar AWD	07.2019 →	B 4204 T11	B	27	1.6 T4F	01.2011 → 12.2015	B 4164 T2	AB	11
<b>V70</b>					2.0	10.2007 → 12.2011	B 4204 S3	B	46
2.0i 20V	01.1997 → 03.2000	B 5204 S	B	17	2.0 BiFuel	03.2013 → 12.2015	B 5204 T9	B	22
2.3i		B 5234 S	B	17	2.0 D	10.2007 → 12.2015	D 4204 T	D	45
2.4F 20V (LPG)	08.1999 → 03.2000	B 5244 SG2	BG	33	2.0 FlexiFuel	01.2008 → 12.2011	B 4204 S4	AB	48
<b>V70 I (875, 876)</b>					2.0 GDI	04.2012 → 12.2015	B 5204 T9	B	22
2.0	01.1997 → 03.2000	B 5202 S	B	18	2.0 T	09.2009 → 12.2011	B 4204 T6	B	47
2.0	01.1997 → 03.2000	B 5204 T2	B	16	2.4 D	04.2007 → 07.2009	D 5244 T5	D	24
2.0	01.1997 → 12.2000	B 5204 T4	B	16	2.4 D	04.2009 → 12.2010	D 5244 T14	D	25
2.0 Turbo	01.1997 → 03.2000	B 5204 T	B	16	2.4 D	08.2009 → 12.2010	D 5244 T19	D	25
2.0 Turbo	01.1997 → 12.2000	B 5204 T3	B	16	2.5 T	08.2007 → 12.2009	B 5254 T6	B	40
2.0 Turbo AWD	01.1997 → 12.2000	B 5204 T3	B	16	2.5 T	04.2009 → 12.2012	B 5254 T10	B	41
2.3	11.1996 → 11.2000	B 5234 T3	B	16	D2	03.2015 → 04.2016	D 4204 T20	D	28
2.3 AWD	04.1997 → 09.1998	B 5234 T3	B	16	D3	10.2007 → 12.2015	D 5204 T7	D	25
2.3 AWD	12.1998 → 02.2000	B 5234 T7	B	16	D3	03.2015 → 04.2016	D 4204 T9	D	28
2.3 AWD	12.1998 → 02.2000	B 5234 T8	B	17	D3 / D4	03.2010 → 12.2015	D 5204 T2	D	25
2.3 T AWD	04.1997 → 03.2000	B 5234 T4	B	19	D3 / D4	03.2010 → 12.2015	D 5204 T3	D	25
2.3 T-5	11.1996 → 12.2000	B 5234 T3	B	16	D4	10.2013 → 04.2016	D 4204 T5	D	28
2.3 T-5 AWD	01.1997 → 12.2000	B 5234 T3	B	16	D4 AWD	10.2007 → 12.2015	D 5244 T17	D	25
2.3 Turbo	12.1995 → 03.2000	B 5234 T4	B	19	D4 AWD	10.2013 → 04.2016	D 5244 T12	D	25
2.4	12.1995 → 05.2000	B 5244 S	B	34	D5	04.2007 → 12.2009	D 5244 T4	D	24
2.4	12.1995 → 05.2000	B 5254 FS	B	35	D5	10.2008 → 12.2011	D 5244 T10	D	26
2.4	01.1997 → 05.2000	B 5254 S	B	34	D5	04.2011 → 12.2015	D 5244 T11	D	25
2.4	06.1998 → 12.1999	B 5254 S	B	34	D5	04.2011 → 12.2015	D 5244 T15	D	25
2.4	03.1999 → 12.2000	B 5244 S2	B	35	D5 AWD	04.2007 → 12.2009	D 5244 T4	D	24
2.4	03.1999 → 12.2000	B 5244 SG2	BG	33	D5 AWD	12.2009 → 12.2011	D 5244 T10	D	26
2.4 AWD	06.1998 → 12.1999	B 5254 S	B	34	D5 AWD	03.2011 → 04.2016	D 5244 T15	D	25
2.4 Bifuel	08.1999 → 12.2000	B 5244 SG	BG	33	D5 AWD	04.2011 → 12.2015	D 5244 T15	D	25
2.4 Turbo	04.1996 → 12.2000	B 5244 T	B	36	T4	03.2015 → 04.2016	B 4204 T19	B	27
2.4 Turbo	01.1997 → 12.2000	B 5254 T	B	34	T5	01.2010 → 12.2014	B 4204 T7	B	47
2.4 Turbo AWD	04.1996 → 12.2000	B 5244 T	B	36	T5	10.2013 → 04.2016	B 4204 T11	B	27

		Pos			Pos
<b>V90 II</b>			2.0 D4	03.2017 →	D 4204 T14 D <b>28</b>
2.0 Turbo	08.2016 →	B 4204 T23 B <b>27</b>	2.0 D4	12.2018 →	D 4204 T7 D <b>28</b>
<b>V90 II Estate (235, 236)</b>			2.0 D4 AWD	03.2017 →	D 4204 T14 D <b>28</b>
2.0 D3	03.2016 → 08.2018	D 4204 T16 D <b>28</b>	2.0 D4 Polestar	05.2020 →	D 4204 T14 D <b>28</b>
2.0 D3	03.2016 → 08.2018	D 4204 T9 D <b>28</b>	2.0 D4 Polestar AWD	05.2020 →	D 4204 T14 D <b>28</b>
2.0 D3 AWD	03.2016 →	D 4204 T4 D <b>28</b>	2.0 D5 AWD	03.2017 →	D 4204 T23 D <b>28</b>
2.0 D4	03.2016 →	D 4204 T14 D <b>28</b>	2.0 D5 Polestar AWD	10.2018 →	D 4204 T23 D <b>28</b>
2.0 D4	09.2018 →	D 4204 T7 D <b>28</b>	2.0 T4	09.2018 →	B 4204 T31 B <b>27</b>
2.0 D4 AWD	03.2016 →	D 4204 T14 D <b>28</b>	2.0 T5	03.2017 → 12.2018	B 4204 T23 B <b>27</b>
2.0 D4 AWD	09.2018 →	D 4204 T7 D <b>28</b>	2.0 T5	10.2017 →	B 4204 T26 B <b>27</b>
2.0 D4 Polestar	10.2016 →	D 4204 T14 D <b>28</b>	2.0 T5 AWD	03.2017 → 12.2018	B 4204 T23 B <b>27</b>
2.0 D5 AWD	03.2016 →	D 4204 T23 D <b>28</b>	2.0 T5 AWD	10.2017 →	B 4204 T20 B <b>27</b>
2.0 Polestar AWD	10.2016 →	D 4204 T14 D <b>28</b>	2.0 T5 AWD	10.2017 →	B 4204 T26 B <b>27</b>
2.0 Polestar AWD	10.2016 →	D 4204 T23 D <b>28</b>	2.0 T5 Polestar AWD	03.2017 → 12.2018	B 4204 T23 B <b>27</b>
2.0 T4	10.2017 →	B 4204 T31 B <b>27</b>	<b>XC70 CROSS COUNTRY I (295)</b>		
2.0 T4 Polestar	06.2019 →	B 4204 T31 B <b>27</b>	2.0 T5 AWD	10.1997 → 03.1999	B 5204 T3 B <b>16</b>
2.0 T5	03.2016 →	B 4204 T23 B <b>27</b>	2.4 D5 AWD	12.2005 → 08.2007	D 5244 T4 D <b>24</b>
2.0 T5	10.2017 →	B 4204 T23 B <b>27</b>	2.4 D5 XC AWD	09.2002 → 08.2007	D 5244 T D <b>24</b>
2.0 T5	10.2017 →	B 4204 T26 B <b>27</b>	2.4 T XC AWD	11.1997 → 09.2002	B 5254 T B <b>34</b>
2.0 T5 AWD	03.2016 → 12.2018	B 4204 T23 B <b>27</b>	2.5 T XC AWD	08.2002 → 07.2007	B 5254 T2 B <b>39</b>
2.0 T5 AWD	03.2016 →	B 4204 T23 B <b>27</b>	2.5 T XC AWD	09.2002 → 08.2007	B 5254 T2 B <b>39</b>
2.0 T5 AWD	10.2017 →	B 4204 T26 B <b>27</b>	<b>XC70 II</b>		
2.0 T5 Polestar	06.2019 →	B 4204 T26 B <b>27</b>	2.4 D3	04.2010 → 04.2012	D 5244 T16 D <b>25</b>
2.0 T5 Polestar AWD	10.2017 →	B 4204 T26 B <b>27</b>	2.4 D3	04.2010 → 04.2012	D 5244 T17 D <b>25</b>
T5 Drive-E Polestar AWD	03.2016 →	B 4204 T23 B <b>27</b>	<b>XC70 II (136)</b>		
<b>XC40 (536)</b>			2.4 D	06.2009 → 12.2010	D 5244 T14 D <b>25</b>
2.0 D3	09.2018 →	D 4204 T16 D <b>28</b>	2.4 D / D4 AWD	08.2007 → 04.2016	D 5244 T16 D <b>25</b>
2.0 D3 AWD	09.2018 →	D 4204 T16 D <b>28</b>	2.4 D / D4 AWD	08.2007 → 04.2016	D 5244 T17 D <b>25</b>
2.0 D4 AWD	10.2017 →	D 4204 T12 D <b>28</b>	2.4 D / D4 AWD	08.2007 → 04.2016	D 5244 T5 D <b>24</b>
D4 Polestar AWD	01.2019 →	D 4204 T12 D <b>28</b>	D3	04.2010 → 12.2015	D 5204 T2 D <b>25</b>
T5 AWD	10.2017 →	B 4204 T14 B <b>27</b>	D3	04.2010 → 12.2015	D 5204 T3 D <b>25</b>
T5 AWD	10.2017 →	B 4204 T14 B <b>27</b>	D4	10.2013 → 04.2016	D 4204 T5 D <b>28</b>
T5 AWD	01.2018 →	B 4204 T14 B <b>27</b>	D4 AWD	10.2013 → 04.2016	D 5244 T12 D <b>25</b>
T5 Polestar AWD	10.2017 → 12.2019	B 4204 T20 B <b>27</b>	D5 AWD	04.2007 → 12.2009	D 5244 T4 D <b>24</b>
<b>XC60 I SUV (156)</b>			D5 AWD	04.2009 → 12.2011	D 5244 T10 D <b>26</b>
2.0 T	12.2009 → 12.2012	B 4204 T6 B <b>47</b>	D5 AWD	04.2011 → 12.2015	D 5244 T11 D <b>25</b>
2.0 T5 Flexfuel	09.2014 → 02.2017	B 4204 T15 B <b>27</b>	D5 AWD	04.2011 → 12.2015	D 5244 T15 D <b>25</b>
2.4 D	04.2009 → 12.2010	D 5244 T14 D <b>25</b>	D5 AWD	11.2013 → 04.2016	D 5244 T15 D <b>25</b>
2.4 D / D3 / D4 AWD	05.2008 → 02.2017	D 5244 T16 D <b>25</b>	D5 AWD	03.2015 → 04.2016	D 5244 T20 D <b>25</b>
2.4 D / D3 / D4 AWD	05.2008 → 02.2017	D 5244 T17 D <b>25</b>	T5	10.2013 → 12.2016	B 4204 T11 B <b>27</b>
2.4 D / D3 / D4 AWD	05.2008 → 02.2017	D 5244 T5 D <b>24</b>	T5 AWD	08.2015 → 12.2016	B 5254 T12 B <b>41</b>
2.4 D3	03.2010 → 04.2012	D 5244 T16 D <b>25</b>	T6 AWD	03.2015 → 12.2016	B 5254 T14 B <b>41</b>
2.4 D3	03.2010 → 04.2012	D 5244 T17 D <b>25</b>	<b>XC90 I (275)</b>		
D3	04.2012 → 12.2015	D 5204 T7 D <b>25</b>	2.5	01.2003 → 12.2006	B 5254 T2 B <b>39</b>
D3	03.2015 → 04.2017	D 4204 T4 D <b>28</b>	2.5 AWD	06.2002 → 12.2014	B 5254 T2 B <b>39</b>
D3 / D4	03.2010 → 12.2014	D 5204 T2 D <b>25</b>	2.5 T AWD	10.2002 → 09.2014	B 5254 T2 B <b>39</b>
D3 / D4	03.2010 → 12.2014	D 5204 T3 D <b>25</b>	D3 / D5	04.2009 → 12.2014	D 5244 T5 D <b>24</b>
D4	10.2013 → 12.2015	D 4204 T5 D <b>28</b>	D5 AWD	10.2002 → 12.2006	D 5244 T D <b>24</b>
D4	03.2015 → 02.2017	D 4204 T14 D <b>28</b>	D5 AWD	04.2005 → 12.2010	D 5244 T4 D <b>24</b>
D4 AWD	10.2013 → 12.2015	D 5244 T12 D <b>25</b>	D5 AWD	10.2007 → 12.2010	D 5244 T5 D <b>24</b>
D4 AWD	03.2015 → 02.2017	D 5244 T21 D <b>25</b>	D5 AWD	01.2011 → 12.2014	D 5244 T18 D <b>25</b>
D5	06.2011 → 02.2017	D 5244 T11 D <b>25</b>	D5 AWD	11.2013 → 09.2014	D 5244 T18 D <b>25</b>
D5	06.2011 → 02.2017	D 5244 T15 D <b>25</b>	T6 AWD	10.2002 → 12.2006	B 6294 T B <b>37</b>
D5 AWD	05.2008 → 12.2009	D 5244 T4 D <b>24</b>	<b>XC90 II (256)</b>		
D5 AWD	07.2009 → 06.2011	D 5244 T10 D <b>26</b>	2.0 B5 Mild-Hybrid AWD	01.2020 →	B 4204 T26 B <b>27</b>
D5 AWD	04.2011 → 12.2015	D 5244 T11 D <b>25</b>	2.0 D5 Polestar AWD	10.2018 →	D 4204 T23 D <b>28</b>
D5 AWD	04.2011 → 12.2015	D 5244 T15 D <b>25</b>	2.0 T5 AWD	02.2016 → 12.2018	B 4204 T23 B <b>27</b>
D5 AWD	04.2014 → 12.2015	D 5244 T23 D <b>25</b>	2.0 T5 AWD	10.2017 →	B 4204 T26 B <b>27</b>
D5 AWD	03.2015 → 02.2017	D 5244 T20 D <b>25</b>	D4	06.2015 → 12.2018	D 4204 T14 D <b>28</b>
D5 AWD	03.2015 → 02.2017	D 5244 T22 D <b>25</b>	D4 AWD	10.2015 → 12.2018	D 4204 T6 D <b>28</b>
T5	09.2010 → 02.2017	B 4204 T7 B <b>47</b>	D5 AWD	09.2014 → 12.2016	D 4204 T11 D <b>28</b>
T5	10.2013 → 02.2017	B 4204 T11 B <b>27</b>	D5 AWD	03.2016 → 12.2019	D 4204 T23 D <b>28</b>
T5 AWD	04.2014 → 02.2017	B 5254 T12 B <b>41</b>	D5 DRIVe Polestar AWD	03.2016 →	D 4204 T23 D <b>28</b>
T5 AWD	04.2014 → 02.2017	B 5254 T12 B <b>41</b>	T5	01.2016 → 12.2016	B 4204 T23 B <b>27</b>
T5 AWD	10.2015 → 02.2017	B 4204 T11 B <b>27</b>	T5 AWD	06.2015 → 12.2018	B 4204 T23 B <b>27</b>
<b>XC60 II (246)</b>			T5 Drive-E Polestar AWD	10.2017 →	B 4204 T23 B <b>27</b>
2.0 B4 Mild-Hybrid AWD	04.2019 →	D 4204 T8 D <b>28</b>	T5 Drive-E Polestar AWD	10.2017 →	B 4204 T26 B <b>27</b>
2.0 D3	03.2017 →	D 4204 T4 D <b>28</b>			

V

					Pos						Pos
						8500	01.1999 →	D9B360	D		93
						8500	01.1999 →	DH12D340	D		142
<b>C303</b>						8500	01.1999 →	DH12D380	D		142
3.0 AWD 05.1974 → 05.1980				B 30 A	B	8500	01.1999 →	DH12D380	D		142
<b>V40 Hatchback Van (525, 526)</b>						8500	01.1999 →	DH12D380	D		142
1.6 D2/ DRIVe 09.2013 → 12.2015				D 4162 T	D	8500	09.2001 →	DH 12 H 340	D		142
2.0 D3 09.2013 → 12.2015				D 5204 T6	D	<b>8700</b>					
2.0 D4 09.2013 → 12.2014				D 5204 T4	D	8700	01.1997 →	DH12D420	D		142
<b>V60 I Estate Van (155)</b>						8700	01.1999 →	D7E 290	D		83
1.6 DRIVe 09.2013 → 12.2015				D 4162 T	D	8700	09.2000 →	DH12D340	D		142
2.0 D3 09.2013 → 12.2015				D 5204 T7	D	8700	09.2000 →	DH12D340	D		142
2.0 D4 09.2013 → 12.2015				D 5204 T3	D	8700	09.2000 →	DH12D340	D		142
2.4 D4 AWD 09.2013 → 12.2015				D 5244 T12	D	8700	09.2000 →	DH12D380	D		142
2.4 D5 09.2013 → 12.2015				D 5244 T15	D	8700	09.2000 →	DH12D380	D		142
<b>V70 III Estate Van (135)</b>						8700	09.2003 →	DH 12 H 340	D		142
2.0 D3 DRIVe 09.2013 →				D 5204 T7	D	8700	10.2007 →	DH12E340	D		142
2.4 D4 AWD 09.2013 →				D 5244 T17	D	8700	10.2007 →	DH12E340	D		142
2.4 D5 09.2013 →				D 5244 T11	D	8700	10.2007 →	DH12E340	D		142
2.4 D5 09.2013 →				D 5244 T15	D	8700	10.2007 →	DH12E380	D		142
<b>XC60 I VAN (156)</b>						8700	10.2007 →	DH12E380	D		142
D3 09.2013 → 12.2015				D 5204 T7	D	<b>8900</b>					
D4 09.2013 → 02.2017				D 5204 T3	D	8900	07.2010 → 12.2013	D7E 290	D		83
D4 AWD 09.2013 → 02.2017				D 5244 T17	D	8900	07.2010 → 12.2013	D7E 290	D		83
D5 AWD 09.2013 → 02.2017				D 5244 T11	D	8900	07.2010 → 12.2013	D9B380	D		93
D5 AWD 09.2013 → 02.2017				D 5244 T15	D	8900, 8900 LOW ENTRY 08.2016 →					
<b>XC70 II VAN (136)</b>						8900, 8900 LOW ENTRY 08.2016 →					
2.0 D4 09.2013 →				D 5204 T3	D	8900, 8900 LOW ENTRY 08.2016 →					
2.4 D4 AWD 09.2013 → 04.2016				D 5244 T17	D	8900, 8900 LOW ENTRY 08.2016 →					
2.4 D5 AWD 09.2013 →				D 5244 T15	D	8900, 8900 LOW ENTRY 08.2016 →					
<b>XC90 I VAN (275)</b>						8900, 8900 LOW ENTRY 08.2016 →					
2.4 D4 09.2013 → 12.2014				D 5244 T5	D	<b>9100</b>					
2.4 D5 AWD 09.2013 → 12.2014				D 5244 T18	D	Asia bus 06.2012 → 11.2016					
						D7E 240 D 88					
<b>7400</b>						<b>9300</b>					
7400 XL 01.2012 →				D7E 290	D	9300	01.2006 →	D9A340	D		94
<b>7700</b>						9300	01.2006 →	D9A340	D		94
7700 01.1998 →				D7C215	D	9300	01.2006 →	D9B260	D		93
7700 01.1998 →				D7C250	D	9300	01.2006 →	D9B260	D		93
7700 01.1998 →				D7C290	D	9300	01.2006 →	D9B310	D		93
7700 01.1998 →				D7C310	D	9300	01.2006 →	D9B310	D		93
7700 06.2006 →				D9B260	D	9300	01.2006 →	D9B340	D		93
7700 06.2006 →				D9B260	D	9300	01.2006 →	D9B340	D		93
7700 06.2006 →				D9B310	D	9300	01.2006 →	D9B360	D		93
7700 06.2006 →				D9B310	D	9300	01.2006 →	D9B360	D		93
7700 06.2006 →				D9B310	D	9300	01.2006 →	D9B360	D		93
7700 06.2006 →				D9B360	D	9300	01.2006 →	D9B380	D		93
7700 06.2006 →				D9B360	D	9300	01.2006 →	D9B380	D		93
<b>7900</b>						<b>9400</b>					
7900 ELECTRIC HYBRID 08.2016 →				D5K240	D	12.0 M	10.2008 → 02.2017	D7E 290	D		83
7900 ELECTRIC HYBRID 08.2016 →				D5K240	D	13.8 M	11.2016 → 03.2020	D11C370	D		114
7900 HYBRID 08.2016 →				D5K240	D	14.5 M	11.2016 → 03.2020	D11C410	D		114
<b>8300</b>						9400	01.2006 →	D9A340	D		94
8300 01.2006 →				D9A340	D	9400	01.2006 →	D9A340	D		94
8300 01.2006 →				D9B260	D	9400	01.2006 →	D9B260	D		93
8300 01.2006 →				D9B260	D	9400	01.2006 →	D9B260	D		93
8300 01.2006 →				D9B310	D	9400	01.2006 →	D9B310	D		93
8300 01.2006 →				D9B310	D	9400	01.2006 →	D9B310	D		93
8300 01.2006 →				D9B310	D	9400	01.2006 →	D9B340	D		93
8300 01.2006 →				D9B340	D	9400	01.2006 →	D9B340	D		93
8300 01.2006 →				D9B340	D	9400	01.2006 →	D9B340	D		93
8300 01.2006 →				D9B360	D	9400	01.2006 →	D9B360	D		93
8300 01.2006 →				D9B360	D	9400	01.2006 →	D9B360	D		93
8300 01.2006 →				D9B360	D	9400	01.2006 →	D9B380	D		93
8300 01.2006 →				D9B380	D	9400	01.2006 →	D9B380	D		93
8300 01.2006 →				D9B380	D	9400	10.2008 → 03.2017	D9B380	D		93
<b>8400</b>						<b>9500</b>					
6080 WB 03.2008 → 12.2016				D7E 290	D	9500	10.2010 → 12.2013	D9B380	D		93
<b>8500</b>						9500	08.2016 →	D8K320	D		91
8500 01.1997 →				DH12D420	D	9500	08.2016 →	D8K350	D		91
8500 01.1999 →				D12D340	D	<b>9700</b>					
						9700	10.2001 →	DH12D340	D		142
						9700	10.2001 →	DH12D340	D		142

V

				Pos					Pos
9700	10.2001 →	DH12D380	D	142	10 BLE	01.1992 → 01.1996	DH10A245	D	109
9700	10.2001 →	DH12D380	D	142	10 BLE	01.1992 → 01.1996	DH10A285	D	109
9700	10.2001 →	DH12D420	D	142	10 BLE	01.1992 → 01.1996	DH10A360	D	109
9700	10.2001 →	DH12D420	D	142	10 BLE	01.1992 → 01.1996	THD 101 GC	D	104
9700	10.2007 →	DH12E340	D	142	10 BLE	01.1992 → 01.1996	THD 101 GD	D	104
9700	10.2007 →	DH12E340	D	142	10 BLE	01.1992 → 01.1996	THD 102 KB	D	111
9700	10.2007 →	DH12E380	D	142	10 BLE	01.1992 → 01.1996	THD 102 KD	D	111
9700	10.2007 →	DH12E380	D	142	10 BLE	01.1992 → 01.1996	THD 102 KF	D	109
9700	10.2007 →	DH12E420	D	142	10 BLE	01.1992 → 01.1996	THD 103 KB	D	109
9700	10.2007 →	DH12E420	D	142	10 BLE	01.1992 → 01.1996	THD 103 KD	D	109
9700	10.2007 →	DH12E460	D	142	10 BLE	01.1992 → 01.1996	THD 103 KF	D	109
9700	10.2007 →	DH12E460	D	142	10 L	05.1994 →	DH10A245	D	109
9700	01.2009 →	D13C420	D	157	10 R	06.1978 → 01.1984	THD 100 D	D	108
9700	01.2009 →	D13C420	D	157	10 R	06.1978 → 01.1984	THD 100 DA	D	108
9700	01.2009 →	D13C420	D	157	10 R	06.1978 → 01.1984	THD 100 DB	D	108
9700	01.2009 →	D13C460	D	150	10 R	06.1978 → 01.1996	TD 101 KC	D	105
9700	01.2009 →	D13C460	D	150	10 R	06.1978 → 01.1996	THD 101 K	D	104
9700	01.2009 →	D13C460	D	150	10 R	10.1979 → 01.1984	THD 100 E	D	106
9700	01.2009 →	D13C500	D	151	10 R	11.1983 → 01.1996	THD 100 EA	D	105
9700	01.2009 →	D13C500	D	151	10 R	11.1983 → 01.1996	THD 100 EB	D	106
9700	01.2009 →	D13C500	D	151	10 R	11.1983 → 01.1996	THD 100 EC	D	106
9700	01.2016 →	D11K430	D	114	10 R	11.1983 → 01.1996	THD 100 ED	D	106
9700	01.2016 →	D11K430	D	114	10 R	11.1983 → 01.1996	THD 100 EE	D	105
9700	01.2016 →	D11K430	D	114	10 R	11.1983 → 01.1996	THD 100 EK	D	105
9700	01.2016 →	D11K460	D	114	B10	01.1978 → 12.2003	THD 101 KE	D	105
9700	01.2016 →	D11K460	D	114	B10	01.1978 → 12.2003	THD 101 KE	D	105
9700	01.2016 →	D11K460	D	114	B10	01.1978 → 12.2003	THD 101 KE	D	105
9700	01.2016 →	D11K460	D	114	B10	01.1978 → 12.2003	THD 102 KA	D	109
9900					B10	01.1978 → 12.2003	THD 102 KA	D	109
9900	10.2001 →	DH12D420	D	142	B10	01.1978 → 12.2003	THD 102 KA	D	109
9900	10.2001 →	DH12D420	D	142	B10	01.1978 → 12.2003	THD 102 KA	D	109
9900	01.2007 →	D13C420	D	157	B10	01.1978 → 12.2003	THD 102 KE	D	109
9900	01.2007 →	D13C460	D	150	B10	01.1978 → 12.2003	THD 102 KE	D	109
9900	10.2007 →	DH12E420	D	142	B10	01.1978 → 12.2003	THD 102 KE	D	109
9900	10.2007 →	DH12E420	D	142	B10	10.1979 → 01.1984	THD 100 DA	D	108
9900	10.2007 →	DH12E460	D	142	B10	10.1980 → 10.1986	TD 101 MC	D	105
9900	10.2007 →	DH12E460	D	142	B10	10.1980 → 10.1986	THD 100 EA	D	105
9900	01.2009 →	D13C420	D	157	B10	1981 → 12.2003	THD 101 K	D	104
9900	01.2009 →	D13C420	D	157	B10	1981 → 12.2003	THD 101 MC	D	105
9900	01.2009 →	D13C460	D	150	B10	01.1985 → 12.2003	DH10A245	D	109
9900	01.2009 →	D13C460	D	150	B10	01.1985 → 12.2003	DH10A245	D	109
9900	08.2016 →	D11K430	D	114	B10	01.1985 → 12.2003	THD 100 DD	D	108
9900	08.2016 →	D11K430	D	114	B10	01.1985 → 12.2003	THD 101 GB	D	104
9900	08.2016 →	D11K430	D	114	B10	01.1985 → 12.2003	THD 101 GB	D	104
9900	08.2016 →	D11K460	D	114	B10	01.1985 → 12.2003	THD 101 GB	D	104
9900	08.2016 →	D11K460	D	114	B10	01.1985 → 12.2003	THD 101 GC	D	104
9900	08.2016 →	D11K460	D	114	B10	01.1985 → 12.2003	THD 101 GC	D	104
<b>A</b>					B10	01.1985 → 12.2003	THD 101 GD	D	104
A25D	01.2005 → 12.2012	D9A300	D	94	B10	01.1985 → 12.2003	THD 101 GD	D	104
A25D	01.2005 → 12.2012	D9A300	D	94	B10	01.1985 → 12.2003	THD 101 KC	D	104
A30D	01.2005 → 12.2012	D9A340	D	94	B10	01.1985 → 12.2003	THD 101 KC	D	104
A30D	01.2005 → 12.2012	D9A340	D	94	B10	01.1985 → 12.2003	THD 101 KC	D	104
A40D	01.2003 → 12.2012	D12A420	D	136	B10	01.1985 → 12.2003	THD 102 KF	D	109
A40D	01.2003 → 12.2012	D12C420	D	138	B10	01.1985 → 12.2003	THD 102 KF	D	109
A40D	01.2003 → 12.2012	D12D420	D	140	B10	01.1985 → 12.2003	THD 103 KF	D	109
<b>B10</b>					B10	01.1985 → 12.2003	THD 103 KF	D	109
10	01.1975 → 1982	THD 101 B	D	105	B10	06.1986 → 01.1996	TD 101 KC	D	105
10	10.1979 → 12.1983	THD 100	D	104	B10	06.1986 → 01.1996	THD 101 G	D	104
10	06.1981 → 08.1999	THD 101 G	D	104	B10	01.1988 → 12.2003	DH10A285	D	109
10 B	01.1992 → 01.1996	DH10A245	D	109	B10	01.1988 → 12.2003	DH10A285	D	109
10 B	01.1992 → 01.1996	DH10A285	D	109	B10	01.1988 → 12.2003	DH10A285	D	109
10 B	01.1992 → 01.1996	DH10A360	D	109	B10	01.1988 → 12.2003	THD 101 KB	D	104
10 B	01.1992 → 01.1996	THD 101 GC	D	104	B10	01.1988 → 12.2003	THD 101 KB	D	104
10 B	01.1992 → 01.1996	THD 101 GD	D	104	B10	01.1988 → 12.2003	THD 101 KB	D	104
10 B	01.1992 → 01.1996	THD 102 KB	D	111	B10	01.1988 → 12.2003	THD 102 KB	D	111
10 B	01.1992 → 01.1996	THD 102 KD	D	111	B10	01.1988 → 12.2003	THD 102 KB	D	111
10 B	01.1992 → 01.1996	THD 102 KF	D	109	B10	01.1988 → 12.2003	THD 102 KB	D	111
10 B	01.1992 → 01.1996	THD 103 KB	D	109	B10	01.1988 → 12.2003	THD 102 KD	D	111
10 B	01.1992 → 01.1996	THD 103 KD	D	109	B10	01.1988 → 12.2003	THD 102 KD	D	111
10 B	01.1992 → 01.1996	THD 103 KF	D	109	B10	01.1988 → 12.2003	THD 102 KD	D	111

**V**



			Pos				Pos		
B10	01.1988 → 12.2003	THD 103 KB	D	109	B 12	10.2010 →	DH12E340	D	142
B10	01.1988 → 12.2003	THD 103 KB	D	109	B12R	01.2012 →	D12D380	D	139
B10	01.1988 → 12.2003	THD 103 KB	D	109	B12R	01.2012 →	D12D420	D	140
B10	01.1988 → 12.2003	THD 103 KD	D	109	<b>B5</b>				
B10	01.1988 → 12.2003	THD 103 KD	D	109	54	10.1965 → 03.1971	TD 70 A	D	72
B10	01.1988 → 12.2003	THD 103 KD	D	109	54	10.1965 → 12.1975	TD 50 B	D	61
B10	01.1990 → 12.2001	THD 101 GC	D	104	54	10.1966 → 03.1971	D 50 A	D	60
B10	01.1990 → 12.2001	THD 101 GD	D	104	54	10.1966 → 03.1971	TD 50 A	D	61
B10	01.1990 → 12.2001	THD 102 KD	D	111	54 T	10.1966 → 03.1971	TD 50 A	D	61
B10	01.1990 → 12.2001	THD 103 KD	D	109	57	01.1965 → 12.1970	D 70 A	D	72
B10	01.1992 → 12.2001	DH10A245	D	109	57	01.1965 → 12.1970	TD 70 A	D	72
B10	01.1992 → 12.2001	DH10A285	D	109	57	10.1965 → 09.1970	D 70 A	D	72
B10	01.1992 → 12.2001	THD 102 KB	D	111	57	10.1965 → 09.1970	TD 70 A	D	72
B10	01.1992 → 12.2001	THD 102 KF	D	109	57	10.1970 → 09.1976	D 70 B	D	72
B10	01.1992 → 12.2001	THD 103 KB	D	109	57	10.1970 → 10.1978	D 50 B	D	60
B10	01.1992 → 12.2001	THD 103 KF	D	109	57	10.1970 → 10.1978	D 50 B	D	60
B10	01.1994 →	THD 100 DC	D	108	57	10.1970 → 10.1978	D 70 B	D	72
B10	01.1995 → 12.2003	DH 10 A 340	D	109	57	1974 →	TD 70 ES	D	71
B10	01.1995 → 12.2003	DH 10 A 350	D	109	57	09.1975 → 12.1981	TD 70 E	D	72
B10	01.1996 → 12.2001	DH10A360	D	109	57	09.1978 → 12.1983	TD 70 H	D	72
B10	01.1996 → 12.2003	DH10A245	D	109	57	09.1978 → 1985	TD 70 F	D	72
B10	01.1996 → 12.2003	DH10A285	D	109	57	09.1978 → 1985	TD 70 FS	D	71
B10	01.1996 → 12.2003	THD 101 GB	D	104	57	09.1978 → 1985	TD 70 G	D	71
B10	01.1996 → 12.2003	THD 101 GC	D	104	57	09.1978 → 01.1996	TD 70 H	D	72
B10	01.1996 → 12.2003	THD 101 GD	D	104	57	06.1979 → 01.1996	TD 70 HA	D	72
B10	01.1996 → 12.2003	THD 101 KB	D	104	57	08.1980 → 12.1983	TD 70 HA	D	72
B10	01.1996 → 12.2003	THD 101 KC	D	104	57	1985 →	TD 71 A	D	72
B10	01.1996 → 12.2003	THD 102 KF	D	109	57	1985 →	TD 71 ACE	D	72
B10	06.2006 → 08.2011	D10B360	D	109	57	1985 →	TD 71 AG	D	72
B10	06.2006 → 08.2011	D10B360	D	109	57	1985 →	TD 71 AGP	D	72
B10	06.2006 → 08.2011	DH10A360	D	109	57	1985 →	TD 71 AP	D	72
<b>B11</b>					57	1985 →	TD 71 APB	D	72
B11R	01.2011 →	D11A430	D	113	57	1985 →	TD 71 AW	D	72
B11R	01.2011 →	D11A430	D	113	57	1985 →	TD 71 FQ	D	72
B11R	09.2011 →	D11C330	D	114	57	1985 →	TD 71 FQK	D	72
B11R	09.2011 →	D11C330	D	114	57	1985 →	TD 71 FS	D	71
B11R	09.2011 →	D11C370	D	114	57	1985 →	TD 71 FSQ	D	72
B11R	09.2011 →	D11C370	D	114	57	1985 →	TD 71 K	D	72
B11R	09.2011 →	D11C410	D	114	57	1987 →	TD 71 G	D	71
B11R	09.2011 →	D11C410	D	114	57 T	10.1965 → 09.1970	TD 70 A	D	72
B11R	09.2013 →	D11K380	D	114	57 T	10.1970 → 10.1975	TD 70 B	D	72
B11R	09.2013 →	D11K380	D	114	57 T	10.1970 → 04.1976	TD 70 B	D	72
B11R	09.2013 →	D11K430	D	114	57 T	11.1975 → 12.1985	TD 70 E	D	72
B11R	09.2013 →	D11K430	D	114	57 T	05.1976 → 12.1978	TD 70 E	D	72
B11R	09.2013 →	D11K460	D	114	58	01.1965 → 03.1983	TD 100 F	D	104
B11R	09.2013 →	D11K460	D	114	58	01.1965 → 03.1983	TD 101 FA	D	104
B11R	04.2020 →	D11K430	D	114	58	01.1965 → 03.1983	TD 101 FD	D	104
<b>B12</b>					58	01.1965 → 03.1983	TD 101 GG	D	106
B 12	01.1991 → 12.2006	TD 123 EC	D	126	58	01.1965 → 03.1983	THD 100 A	D	105
B 12	01.1992 → 12.1994	TD 122 FH	D	135	58	01.1965 → 03.1983	THD 100 E	D	106
B 12	01.1992 → 12.1994	TD 122 FL	D	135	58	1969 → 1974	TMD 100 A	D	104
B 12	01.1992 → 12.1994	TD 123 ES	D	135	58	08.1972 → 03.1980	HD 100 D	D	104
B 12	10.1995 →	D 12 A 370	D	141	58	1975 → 1982	THD 101 B	D	105
B 12	10.1995 →	D 12 A 415	D	141	58 E	09.1979 → 08.1983	THD 100 D	D	108
B 12	10.1995 →	D12A420	D	136	58 E	09.1983 → 12.1988	THD 100 EB	D	106
B 12	02.2006 →	D12C420	D	138	58 E	09.1983 → 12.1988	THD 101 GC	D	104
B 12	02.2006 →	D12C420	D	138	58 E	09.1983 →	THD 100 E	D	106
B 12	02.2006 →	D12D380	D	139	58 E	09.1983 →	THD 100 EC	D	106
B 12	02.2006 →	D12D420	D	140	58 E	09.1983 →	THD 100 ED	D	106
B 12	02.2006 →	D12D420	D	140	58 E	09.1983 →	THD 101 GD	D	104
B 12	02.2006 →	DH12D340	D	142	58 E	04.1987 →	THD 101 GB	D	104
B 12	02.2006 →	DH12E380	D	142	58 E	01.1994 →	THD 101 KB	D	104
B 12	10.2007 →	DH12E340	D	142	58 E	01.1994 →	THD 102 KF	D	109
B 12	10.2007 →	DH12E340	D	142	58 E	01.1994 →	THD 102 KJ	D	109
B 12	10.2007 →	DH12E380	D	142	58 T	04.1966 → 03.1980	THD 100 A	D	105
B 12	10.2007 →	DH12E420	D	142	58 T	04.1966 → 03.1980	THD 100 D	D	108
B 12	10.2007 →	DH12E420	D	142	59	01.1965 → 03.1983	THD 100 A	D	105
B 12	10.2007 →	DH12E460	D	142	59	1969 → 1974	TMD 100 A	D	104
B 12	10.2007 →	DH12E460	D	142	59	10.1972 → 01.1979	THD 100 D	D	108



				Pos					Pos
59	1975 → 1982	THD 101 B	D	105	230	01.1977 → 1981	TD 120 A	D	126
59 T	03.1971 → 01.1979	THD 100 D	D	108	230	01.1977 → 1981	TMD 120 A	D	125
59 T	10.1972 → 01.1979	THD 100 A	D	105	230	06.1984 → 01.1987	TD 121 GD	D	122
<b>B6</b>					230 T	09.1979 → 10.1984	TD 120 FC	D	126
6 F	11.1978 → 07.1984	TD 60 A	D	66	230 T	10.1979 → 1984	TD 120 F	D	126
6 F	11.1978 → 07.1984	TD 60 C	D	66	230 T	1980 → 1984	TAMD 120 A	D	125
6 F	11.1979 → 12.1987	TD 60 B	D	66	230 T	1980 → 1984	TAMD 120 AK	D	127
6 FA	11.1979 → 12.1987	TD 60 B	D	66	230 T	1980 → 1984	TAMD 120 B	D	125
609	03.1975 → 03.1978	D 60	D	66	230 T	1980 → 1984	TAMD 120 BCC	D	127
609	01.1977 → 03.1978	D 60 A	D	66	230 T	1980 → 1984	TD 120 G	D	126
B 6	01.1991 → 12.2006	D7E 290	D	83	230 T	1980 → 1984	TD 122 GB	D	126
B6R, B6LE	11.1991 → 12.1994	TD 63 E	D	69	230 T	1980 → 1984	TD 122 KBE	D	126
B6R, B6LE	11.1991 → 12.1994	TD 63 ES	D	69	230 T	10.1980 → 1984	TD 120 GA	D	126
<b>B7</b>					300	01.1975 → 12.1982	THD 100 D	D	108
7	01.1991 →	TD 73 ES	D	75	400	01.1975 → 12.1982	THD 100 D	D	108
7 F	10.1983 → 12.1987	TD 70 H	D	72	400	01.1975 →	TD 101 KC	D	105
7 F	01.1999 →	D7A230	D	74	400	01.1975 →	THD 101 K	D	104
7 F	01.1999 →	D7A260	D	74	400	1982 →	THD 100 DB	D	108
7 F	01.1999 →	D7A285	D	74	400	1982 →	THD 100 DC	D	108
7 F	01.1999 →	D7B230	D	74	400	1982 →	THD 100 DD	D	108
7 F	01.1999 →	D7B260	D	74	400	1982 →	THD 100 E	D	106
7 FA	10.1983 → 12.1987	TD 70 H	D	72	400	1982 →	THD 100 EB	D	106
7 L	05.1999 →	D7C215	D	79	400	1982 →	THD 100 EC	D	106
7 L	05.1999 →	D7C250	D	79	400	1982 →	THD 100 ED	D	106
7 L	05.1999 →	D7C290	D	79	<b>F10</b>				
7 L	05.1999 →	D7C310	D	79	F 10/210	01.1976 → 12.1983	TD 100 A	D	108
715	01.1963 → 12.1964	TD 70 A	D	72	F 10/210	01.1976 → 12.1983	TD 100 A	D	108
B 7	01.1998 →	D7E 290	D	83	F 10/240	01.1976 → 12.1983	TD 100 G	D	106
B 7	01.1998 →	D7E 290	D	83	F 10/240	01.1976 → 12.1983	TD 100 G	D	106
B 7	01.1998 →	D7E 290	D	83	F 10/260	02.1982 → 06.1985	TD 100 G	D	106
B 7 R	09.2008 →	D7E 290	D	83	F 10/260	02.1982 → 06.1985	TD 100 G	D	106
B7R	10.2001 → 12.2007	D7B260	D	74	F 10/260	02.1982 → 06.1985	TD 100 G	D	106
B7R	09.2011 → 12.2016	D7E 290	D	83	F 10/260	02.1982 → 06.1985	TD 100 G	D	106
<b>B9</b>					F 10/260	02.1982 → 06.1985	TD 100 G	D	106
9 M	08.1982 → 07.1994	THD 100 D	D	108	F 10/260	02.1982 → 06.1985	TD 100 G	D	106
9 M	08.1982 → 07.1994	THD 101 GB	D	104	F 10/260	02.1982 → 06.1985	TD 100 GA	D	106
9 M	08.1982 → 07.1994	THD 101 GC	D	104	F 10/260	02.1982 → 06.1985	TD 100 GA	D	106
9 M	08.1982 →	TD 101 KC	D	105	F 10/260	02.1982 → 06.1985	TD 100 GA	D	106
9 M	08.1982 →	THD 101 K	D	104	F 10/260	02.1982 → 06.1985	TD 100 GA	D	106
9 M	01.1994 →	THD 102 KF	D	109	F 10/260	02.1982 → 06.1985	TD 100 GA	D	106
9400	10.2008 →	D9B380	D	93	F 10/260	02.1982 → 06.1985	TD 100 GA	D	106
B 9	09.2005 →	D9B260	D	93	F 10/260	01.1983 → 06.1985	TD 100 G	D	106
B 9	09.2005 →	D9B260	D	93	F 10/260	01.1983 → 06.1985	TD 100 GA	D	106
B 9	09.2005 →	D9B310	D	93	F 10/260	10.1983 → 06.1985	TD 101 G	D	104
B 9	09.2005 →	D9B310	D	93	F 10/260	10.1983 → 06.1985	TD 101 G	D	104
B 9	09.2005 →	D9B360	D	93	F 10/260	10.1983 → 06.1985	TD 101 G	D	104
B 9	09.2005 →	D9B360	D	93	F 10/260	10.1983 → 06.1985	TD 101 G	D	104
B 9	05.2010 →	D9B340	D	93	F 10/260	10.1983 → 06.1985	TD 101 G	D	104
B 9	05.2010 →	D9B380	D	93	F 10/260	10.1983 → 06.1985	TD 101 G	D	104
B9R	10.2008 → 03.2017	D9B340	D	93	F 10/260	10.1983 → 06.1985	TD 101 G	D	104
<b>BUS 5000 SERIES</b>					F 10/260	01.1984 → 12.1986	TD 101 G	D	104
5000	08.1999 →	D7C215	D	79	F 10/270	01.1976 → 12.1983	TD 100 GA	D	106
5000	08.1999 →	D7C250	D	79	F 10/270	01.1976 → 12.1983	TD 100 GA	D	106
5000	08.1999 →	D7C290	D	79	F 10/270	01.1984 → 12.1986	TD 101 GA	D	104
<b>BUS 7000 SERIES</b>					F 10/270	01.1984 → 12.1986	TD 101 GA	D	104
7000	08.1998 →	D7C215	D	79	F 10/270	01.1984 → 12.1986	TD 101 GA	D	104
7000	08.1998 →	D7C250	D	79	F 10/280	01.1976 → 12.1983	TD 100 B	D	104
7000	08.1998 →	D7C290	D	79	F 10/280	01.1976 → 12.1983	TD 100 B	D	104
7000	04.1999 →	D12A420	D	136	F 10/280	01.1976 → 12.1983	TD 100 BG	D	104
<b>BUS B13 SERIES</b>					F 10/280	01.1976 → 12.1983	TD 100 BG	D	104
B13R	01.2012 →	D13C420	D	157	F 10/280	08.1977 → 02.1982	TD 100 B	D	104
B13R	01.2012 →	D13C460	D	150	F 10/280	08.1977 → 02.1982	TD 100 B	D	104
<b>CH SERIES</b>					F 10/280	08.1977 → 02.1982	TD 100 B	D	104
200	01.1978 → 1985	TD 60 B	D	66	F 10/280	08.1977 → 02.1982	TD 100 B	D	104
200	10.1979 → 1988	TD 120 F	D	126	F 10/280	08.1977 → 02.1982	TD 100 B	D	104
200	10.1979 → 05.1988	TD 121 F	D	122	F 10/290	01.1984 → 12.1986	TD 101 F	D	104
200	10.1980 → 06.1986	TD 120 G	D	126	F 10/290	01.1984 → 12.1986	TD 101 F	D	104
200	10.1980 → 06.1986	TD 120 GA	D	126	F 10/290	01.1984 → 12.1986	TD 101 F	D	104
230	01.1977 → 1981	TAMD 120 A	D	125	F 10/300	01.1984 → 12.1986	TD 101 FA	D	104







				Pos					Pos
F 16/470	01.1988 → 12.1989	TD 162 FL	D	173	716	01.1979 → 1985	TD 70 FS	D	71
F 16/470	01.1988 → 12.1989	TD 162 FL	D	173	716	01.1979 → 1985	TD 70 G	D	71
F 16/470	01.1988 → 12.1989	TD 162 FL	D	173	720	01.1979 → 1985	TD 70 F	D	72
F 16/470	01.1988 → 12.1989	TD 162 FL	D	173	720	01.1979 → 1985	TD 70 FS	D	71
F 16/470	01.1988 → 12.1989	TD 162 FS	D	173	720	01.1979 → 1985	TD 70 G	D	71
F 16/470	01.1988 → 12.1989	TD 162 FS	D	173	724	01.1979 → 1985	TD 70 F	D	72
F 16/470	01.1988 → 12.1989	TD 162 FS	D	173	724	01.1979 → 1985	TD 70 FS	D	71
F 16/470	01.1988 → 12.1989	TD 162 FS	D	173	724	01.1979 → 1985	TD 70 G	D	71
F 16/485	01.1987 → 12.1995	TD 162 FL	D	173	F 7	08.1978 → 12.1985	TD 70 F	D	72
F 16/485	01.1987 → 12.1995	TD 162 FL	D	173	F 7	08.1978 → 12.1985	TD 70 F	D	72
F 16/485	01.1987 → 12.1995	TD 162 FL	D	173	F 7	08.1978 → 12.1985	TD 70 F	D	72
F 16/485	01.1987 → 12.1995	TD 162 FS	D	173	F 7	08.1978 → 12.1985	TD 70 F	D	72
F 16/485	01.1987 → 12.1995	TD 162 FS	D	173	F 7	08.1978 → 12.1985	TD 70 FS	D	71
F 16/485	01.1987 → 12.1995	TD 162 FS	D	173	F 7	08.1978 → 12.1985	TD 70 FS	D	71
F 16/485	01.1990 → 12.1992	TD 162 F	D	173	F 7	08.1978 → 12.1985	TD 70 FS	D	71
F 16/485	01.1990 → 12.1992	TD 162 F	D	173	F 7	08.1978 → 12.1985	TD 70 FS	D	71
F 16/485	01.1990 → 12.1992	TD 162 F	D	173	F 7	08.1978 → 12.1985	TD 70 FS	D	71
F 16/485	01.1990 → 12.1992	TD 162 F	D	173	F 7	08.1978 → 12.1985	TD 70 FS	D	71
F 16/485	01.1990 → 12.1992	TD 162 F	D	173	F 7	08.1978 → 12.1985	TD 70 FS	D	71
F 16/485	01.1990 → 12.1992	TD 162 F	D	173	F 7	08.1978 → 12.1985	TD 70 FS	D	71
F 16/485	01.1990 → 12.1992	TD 162 F	D	173	F 7	08.1978 → 12.1985	TD 70 FS	D	71
F 16/485	01.1990 → 12.1992	TD 162 FJ	D	173	F 7	03.1983 → 12.1985	TD 70 G	D	71
F 16/485	01.1990 → 12.1992	TD 162 FJ	D	173	F 7	03.1983 → 12.1985	TD 70 G	D	71
F 16/485	01.1990 → 12.1992	TD 162 FJ	D	173	F 7	03.1983 → 12.1985	TD 70 G	D	71
F 16/485	01.1990 → 12.1992	TD 162 FJ	D	173	F 7	03.1983 → 12.1985	TD 70 G	D	71
F 16/485	01.1990 → 12.1992	TD 162 FJ	D	173	F 7	03.1983 → 12.1985	TD 70 G	D	71
F 16/485	01.1990 → 12.1992	TD 162 FJ	D	173	F 7	03.1983 → 12.1985	TD 70 G	D	71
F 16/485	01.1990 → 12.1992	TD 162 FL	D	173	F 7	03.1983 → 12.1985	TD 70 G	D	71
F 16/485	01.1990 → 12.1992	TD 162 FL	D	173	F 7	03.1983 → 12.1985	TD 70 G	D	71
F 16/485	01.1990 → 12.1992	TD 162 FL	D	173	F 7	11.1984 → 12.1985	TD 70 FC	D	72
F 16/485	01.1990 → 12.1992	TD 162 FL	D	173	F 7	1985 → 12.1985	TD 71 FQK	D	72
F 16/485	01.1990 → 12.1992	TD 162 FL	D	173	F 7	1985 → 12.1985	TD 71 K	D	72
F 16/485	01.1990 → 12.1992	TD 162 FL	D	173	F80				
F 16/485	01.1990 → 12.1992	TD 162 FS	D	173	82	09.1975 → 01.1986	4.236	D	67
F 16/485	01.1990 → 12.1992	TD 162 FS	D	173	82	09.1975 → 01.1986	D 39 C	D	67
F 16/485	01.1990 → 12.1992	TD 162 FS	D	173	83	09.1975 → 01.1986	4.236	D	67
F 16/485	01.1990 → 12.1992	TD 162 FS	D	173	83	09.1975 → 01.1986	D 39 C	D	67
F 16/485	01.1990 → 12.1992	TD 162 FS	D	173	84	10.1965 → 08.1970	D 50 A	D	60
F 16/485	01.1990 → 12.1992	TD 162 FS	D	173	84	10.1965 → 08.1974	TD 50 A	D	61
F 16/500	01.1987 → 12.1995	TD 163 ES	D	173	84	09.1970 → 12.1974	D 50 B	D	60
F 16/500	01.1987 → 12.1995	TD 163 ES	D	173	84	09.1970 → 10.1978	TD 50 B	D	61
F 16/500	01.1987 → 12.1995	TD 163 ES	D	173	84 T	01.1972 → 10.1978	TD 50 B	D	61
F 16/500	01.1992 → 12.1994	TD 163 ES	D	173	85	10.1965 → 08.1970	D 50 A	D	60
F 16/500	01.1992 → 12.1994	TD 163 ES	D	173	85	10.1965 → 08.1970	TD 50 A	D	61
F 16/500	01.1992 → 12.1994	TD 163 ES	D	173	85	09.1970 → 12.1974	TD 50 B	D	61
F 16/500	01.1992 → 12.1994	TD 163 ES	D	173	85	01.1972 → 12.1974	D 50 B	D	60
F 16/500	01.1992 → 12.1994	TD 163 ES	D	173	85 T	10.1965 → 08.1970	TD 50 A	D	61
F 16/500	01.1992 → 12.1994	TD 163 ES	D	173	85 T	09.1970 → 12.1971	TD 50 B	D	61
F 16/500	01.1992 → 12.1994	TD 163 ES	D	173	85 T	04.1978 → 10.1978	TD 60 A	D	66
F4					85 T	04.1978 → 10.1978	TD 60 A	D	66
407	09.1975 → 01.1986	4.236	D	67	87	09.1976 → 05.1978	TD 70 E	D	72
407	09.1975 → 01.1986	D 39 C	D	67	87	09.1976 → 08.1978	TD 70 ES	D	71
F6					88	01.1965 → 12.1981	MD 100 B	D	105
607	03.1975 → 03.1978	TD 60 A	D	66	88	08.1965 → 10.1969	D 100 A	D	107
F 609	03.1975 → 03.1978	D 60	D	66	88	10.1969 → 12.1971	D 100 B	D	107
F 609	01.1977 → 02.1980	D 60 A	D	66	88	1970 → 12.1981	D 120	D	124
F 610	02.1980 → 1985	TAMD 60 C	D	68	88	1976 → 1981	TD 100 BG	D	104
F 610	02.1980 → 02.1986	TD 60 C	D	66	88 H	10.1974 → 06.1977	TD 100 B	D	104
F 611	09.1975 → 03.1978	D 60	D	66	F 86/207	06.1970 → 12.1974	TMD 70 B	D	72
F 611	01.1977 → 01.1980	D 60 A	D	66	F 86/207	08.1970 → 09.1974	TD 70 B	D	72
F 611	1978 → 01.1980	TAMD 60 C	D	68	F 86/207	1971 → 09.1974	TD 70 B	D	72
F 611	02.1980 → 02.1986	TD 60 C	D	66	F 88/260	08.1965 → 06.1977	TD 100 A	D	108
F 612	04.1983 → 1985	TAMD 60 C	D	68	F 89/330	10.1970 → 06.1977	TD 120 A	D	126
F 612	04.1983 → 02.1986	TD 60 C	D	66	F 89/330	10.1970 → 06.1977	TD 120 A	D	126
F 613,F 614	09.1975 → 11.1978	TD 60 A	D	66	FB				
F 613,F 614	12.1978 → 02.1986	TD 60 B	D	66	84 T	09.1970 → 12.1971	TD 50 B	D	61
F 615 S	12.1978 → 10.1981	TD 60 B	D	66	85 T	09.1970 → 12.1971	TD 50 B	D	61
F 616	02.1981 → 02.1986	TD 60 B	D	66	86	10.1965 → 05.1970	D 70 A	D	72
F 617 S	12.1978 → 02.1986	TD 60 B	D	66	86	10.1965 → 09.1970	TD 70 A	D	72
F7					86	06.1970 → 12.1974	D 70 B	D	72
716	01.1979 → 1985	TD 70 F	D	72	86	06.1970 → 12.1974	TD 70 B	D	72

V

				Pos					Pos
86	06.1970 → 12.1974	TD 70 C	D	72	400	09.2005 →	D13A400	D	153
86	06.1970 → 12.1974	TMD 70 B	D	72	400	09.2005 →	D13A400	D	153
86 T	10.1965 → 05.1970	TD 70 A	D	72	400	09.2005 →	D13A400	D	153
86 T	08.1970 → 09.1974	TD 70 B	D	72	400	09.2005 →	D13A400	D	153
86 T	10.1974 → 05.1978	TD 70 ES	D	71	400	09.2005 →	D13A400	D	153
86 T	10.1974 → 06.1978	TD 70 E	D	72	400	09.2005 →	D13A400	D	153
87 BFA	09.1976 → 05.1978	TD 70 ES	D	71	400	09.2005 →	D13A400	D	153
88	01.1976 → 1981	TD 100 BG	D	104	400	09.2005 →	D13A400	D	153
88 T	08.1965 → 06.1977	TD 100 A	D	108	400	09.2005 →	D13A400	D	153
<b>FE</b>					400	09.2005 →	D13A400	D	153
613	03.1986 → 12.1997	TD 61 GE	D	66	400	09.2005 →	D13A400	D	153
614	03.1986 → 12.1997	TD 61 FB	D	66	400	09.2005 →	D13A400	D	153
615	03.1986 → 12.1997	TD 61 FB	D	66	400	09.2005 →	D13A400	D	153
715	07.1986 → 12.1997	TD 71 FA	D	72	400	09.2005 →	D13B400	D	155
715	07.1986 → 12.1997	TD 71 FC	D	72	400	09.2005 →	D13B400	D	155
716	07.1986 → 12.1997	TD 71 FA	D	72	400	09.2005 →	D13B400	D	155
716	07.1986 → 12.1997	TD 71 FC	D	72	400	09.2005 →	D13B400	D	155
FE 240-18	05.2006 →	D7E 240	D	88	400	09.2007 →	D13B400	D	155
FE 240-18	05.2006 →	D7E 240	D	88	400	09.2007 →	D13B400	D	155
FE 240-18	05.2006 →	D7E 240	D	88	400	09.2007 →	D13B400	D	155
FE 240-22	05.2006 →	D7E 240	D	88	400	09.2007 →	D13B400	D	155
FE 240-26	05.2006 →	D7E 240	D	88	400	09.2007 →	D13B400	D	155
FE 240-26	05.2006 →	D7E 240	D	88	400	09.2007 →	D13B400	D	155
FE 240-26	05.2006 →	D7E 240	D	88	400	09.2007 →	D13B400	D	155
FE 240-26	05.2006 →	D7E 240	D	88	400	09.2007 →	D13B400	D	155
FE 240-26	05.2006 →	D7E 240	D	88	400	09.2007 →	D13B400	D	155
FE 240-26	05.2006 →	D7E 240	D	88	400	09.2007 →	D13B400	D	155
FE 280-18	05.2006 →	D7E 280	D	88	420	09.2005 →	D13A420	D	154
FE 280-18	05.2006 →	D7E 280	D	88	420	01.2009 →	D13C420	D	157
FE 280-18	05.2006 →	D7E 280	D	88	420	01.2009 →	D13C420	D	157
FE 280-22	05.2006 →	D7E 280	D	88	420	01.2009 →	D13C420	D	157
FE 280-26	05.2006 →	D7E 280	D	88	420	01.2009 →	D13C420	D	157
FE 280-26	05.2006 →	D7E 280	D	88	420	01.2009 →	D13C420	D	157
FE 280-26	05.2006 →	D7E 280	D	88	420	01.2009 →	D13C420	D	157
FE 280-26	05.2006 →	D7E 280	D	88	420	01.2009 →	D13C420	D	157
FE 280-26	05.2006 →	D7E 280	D	88	420	01.2009 →	D13C420	D	157
FE 280-26	05.2006 →	D7E 280	D	88	420	01.2009 →	D13C420	D	157
FE 320-18	05.2006 →	D7E 320	D	88	420	01.2009 →	D13C420	D	157
FE 320-18	05.2006 →	D7E 320	D	88	420	01.2009 →	D13C420	D	157
FE 320-18	05.2006 →	D7E 320	D	88	420	01.2009 →	D13C420	D	157
FE 320-22	05.2006 →	D7E 320	D	88	420	01.2016 →	D13C420	D	157
FE 320-26	05.2006 →	D7E 320	D	88	420	01.2016 →	D13C420	D	157
FE 320-26	05.2006 →	D7E 320	D	88	420	01.2016 →	D13C420	D	157
FE 320-26	05.2006 →	D7E 320	D	88	440	09.2005 →	D13A440	D	152
FE 320-26	05.2006 →	D7E 320	D	88	440	09.2005 →	D13A440	D	152
FE 320-26	05.2006 →	D7E 320	D	88	440	09.2005 →	D13A440	D	152
<b>FE II</b>					440	09.2005 →	D13A440	D	152
FE 240-18	05.2012 →	D7E 240	D	88	440	09.2005 →	D13A440	D	152
FE 240-26	05.2012 →	D7E 240	D	88	440	09.2005 →	D13A440	D	152
FE 250-18	05.2012 →	D8K250	D	91	440	09.2005 →	D13A440	D	152
FE 250-26	05.2012 →	D8K250	D	91	440	09.2005 →	D13A440	D	152
FE 280-18	05.2012 →	D7E 280	D	88	440	09.2005 →	D13A440	D	152
FE 280-18	05.2012 →	D8K280	D	91	440	09.2005 →	D13A440	D	152
FE 280-18	05.2012 →	D8K280	D	91	440	09.2005 →	D13A440	D	152
FE 280-26	05.2012 →	D7E 280	D	88	440	09.2005 →	D13A440	D	152
FE 280-26	05.2012 →	D8K280	D	91	440	09.2005 →	D13A440	D	152
FE 280-26	05.2012 →	D8K280	D	91	440	09.2005 →	D13B440	D	155
FE 280-26	05.2013 →	D7E 280	D	88	440	09.2005 →	D13B440	D	155
FE 320-18	05.2012 →	D7E 320	D	88	440	09.2005 →	D13B440	D	155
FE 320-18	05.2012 →	D8K320	D	91	440	09.2005 →	D13B440	D	155
FE 320-18	05.2012 →	D8K320	D	91	440	09.2006 → 12.2011	D13A440	D	152
FE 320-26	05.2012 →	D7E 320	D	88	440	09.2006 → 12.2011	D13A440	D	152
FE 320-26	05.2012 →	D8K320	D	91	440	09.2007 → 12.2011	D13B440	D	155
FE 320-26	05.2012 →	D8K320	D	91	440	09.2007 → 12.2011	D13B440	D	155
FE 320-26	05.2013 →	D7E 320	D	88	440	09.2007 →	D13B440	D	155
<b>FH</b>					440	09.2007 →	D13B440	D	155
12	01.1998 →	D 12 C	D	143	440	09.2007 →	D13B440	D	155
16-470	08.1993 → 12.1999	D16A470	D	173	440	09.2007 →	D13B440	D	155
16-470	08.1998 → 01.2003	D 16 B 470	D	173	440	09.2007 →	D13B440	D	155
360		D13B360	D	155	440	09.2007 →	D13B440	D	155

V





























































			Pos				Pos
420	04.2010 →	D13C420	D 157	480	01.2011 → 12.2011	D13A480	D 152
420	01.2011 →	D13C420	D 157	500	04.2010 →	D13C500	D 151
420	01.2011 →	D13C420	D 157	500	04.2010 →	D13C500	D 151
420	01.2012 →	D13C420	D 157	500	04.2010 →	D13C500	D 151
430	04.2010 →	D11A430	D 113	500	04.2010 →	D13C500	D 151
440	04.2010 →	D13A440	D 152	500	04.2010 →	D13C500	D 151
440	01.2011 → 12.2011	D13A440	D 152	500	04.2010 →	D13C500	D 151
450	04.2010 →	D11C450	D 114	500	04.2010 →	D13C500	D 151
450	04.2010 →	D11C450	D 114	500	04.2010 →	D13C500	D 151
450	04.2010 →	D11C450	D 114	500	04.2010 →	D13C500	D 151
450	04.2010 →	D11C450	D 114	500	04.2010 →	D13C500	D 151
450	04.2010 →	D11C450	D 114	500	04.2010 →	D13C500	D 151
450	04.2010 →	D11C450	D 114	500	04.2010 →	D13C500	D 151
450	04.2010 →	D11C450	D 114	500	04.2010 →	D13C500	D 151
450	04.2010 →	D11C450	D 114	500	04.2010 →	D13C500	D 151
450	04.2010 →	D11C450	D 114	500	04.2010 →	D13C500	D 151
450	04.2010 →	D11C450	D 114	500	04.2010 →	D13C500	D 151
450	04.2010 →	D11C450	D 114	500	04.2010 →	D13C500	D 151
450	04.2010 →	D11C450	D 114	500	04.2010 →	D13C500	D 151
450	04.2010 →	D11C450	D 114	500	04.2010 →	D13C500	D 151
450	04.2010 →	D11C450	D 114	500	04.2010 →	D13C500	D 151
450	04.2010 →	D11C450	D 114	500	04.2010 →	D13C500	D 151
450	04.2010 →	D11C450	D 114	500	04.2010 →	D13C500	D 151
450	04.2010 →	D11C450	D 114	500	01.2011 →	D13C500	D 151
450	04.2010 →	D11C450	D 114	500	01.2012 →	D13C500	D 151
450	04.2010 →	D11C450	D 114	500	01.2012 →	D13C500	D 151
450	04.2010 →	D11C450	D 114	540	04.2010 →	D13C540	D 151
450	04.2010 →	D11C450	D 114	540	04.2010 →	D13C540	D 151
450	04.2010 →	D11C450	D 114	540	04.2010 →	D13C540	D 151
460	04.2010 →	D13C460	D 150	540	04.2010 →	D13C540	D 151
460	04.2010 →	D13C460	D 150	540	04.2010 →	D13C540	D 151
460	04.2010 →	D13C460	D 150	540	04.2010 →	D13C540	D 151
460	04.2010 →	D13C460	D 150	540	04.2010 →	D13C540	D 151
460	04.2010 →	D13C460	D 150	540	04.2010 →	D13C540	D 151
460	04.2010 →	D13C460	D 150	540	04.2010 →	D13C540	D 151
460	04.2010 →	D13C460	D 150	540	04.2010 →	D13C540	D 151
460	04.2010 →	D13C460	D 150	540	04.2010 →	D13C540	D 151
460	04.2010 →	D13C460	D 150	540	04.2010 →	D13C540	D 151
460	04.2010 →	D13C460	D 150	540	04.2010 →	D13C540	D 151
460	04.2010 →	D13C460	D 150	540	04.2010 →	D13C540	D 151
460	04.2010 →	D13C460	D 150	540	04.2010 →	D13C540	D 151
460	04.2010 →	D13C460	D 150	540	04.2010 →	D13C540	D 151
460	04.2010 →	D13C460	D 150	540	04.2010 →	D13C540	D 151
460	04.2010 →	D13C460	D 150	540	04.2010 →	D13C540	D 151
460	04.2010 →	D13C460	D 150	540	04.2010 →	D13C540	D 151
460	04.2010 →	D13C460	D 150	540	04.2010 →	D13C540	D 151
460	04.2010 →	D13C460	D 150	540	04.2010 →	D13C540	D 151
460	04.2010 →	D13C460	D 150	540	04.2010 →	D13C540	D 151
460	04.2010 →	D13C460	D 150	540	01.2011 →	D13C540	D 151
460	04.2010 →	D13C460	D 150	540	01.2011 →	D13C540	D 151
460	04.2010 →	D13C460	D 150	330	FMX II		
460	04.2010 →	D13C460	D 150	330	04.2012 →	D11K330	D 115
460	01.2011 →	D13C460	D 150	330	04.2012 →	D11K330	D 115
460	01.2012 →	D13C460	D 150	330	04.2012 →	D11K330	D 115
460	01.2012 →	D13C460	D 150	330	04.2012 →	D11K330	D 115
480	04.2010 →	D13A480	D 152	330	04.2012 →	D11K330	D 115
480	04.2010 →	D13A480	D 152	330	04.2012 →	D11K330	D 115





			Pos				Pos		
540	09.2013 →	D13K540	D	162	86 T	08.1970 → 08.1973	TD 70 B	D	72
540	09.2013 →	D13K540	D	162	88	01.1965 → 1975	MD 100 B	D	105
540	06.2016 →	D13K540	D	162	88	08.1965 → 10.1969	D 100 A	D	107
540	06.2016 →	D13K540	D	162	88	11.1969 → 12.1971	D 100 B	D	107
540	06.2016 →	D13K540	D	162	88 T	08.1965 → 12.1969	TD 100 A	D	108
540	06.2016 →	D13K540	D	162	88 TS	01.1970 → 08.1973	TD 100 A	D	108
540	06.2016 →	D13K540	D	162	<b>N10</b>				
540	06.2016 →	D13K540	D	162	N 10/250	01.1980 → 12.1989	TD 100 C	D	108
540	06.2016 →	D13K540	D	162	N 10/250	01.1980 → 12.1989	TD 100 C	D	108
540	06.2016 →	D13K540	D	162	N 10/250	01.1980 → 12.1989	TD 100 C	D	108
FMX 520	09.2014 →	D13A520	D	152	N 10/250	01.1980 → 12.1989	TD 100 C	D	108
FMX 520	09.2014 →	D13A520	D	152	N 10/250	01.1980 → 12.1989	TD 101 GB	D	105
<b>FS SERIES</b>					N 10/250	01.1980 → 12.1989	TD 101 GB	D	105
10	01.1987 → 01.1989	TD 101 FD	D	104	N 10/250	01.1980 → 12.1989	TD 101 GB	D	105
10	01.1987 →	TD 100 F	D	104	N 10/250	01.1980 → 12.1989	TD 101 GB	D	105
10	01.1987 →	TD 101 FA	D	104	N 10/260	01.1980 → 12.1989	TD 101 G	D	104
10	01.1987 →	TD 101 GG	D	106	N 10/260	01.1980 → 12.1989	TD 101 G	D	104
10	01.1987 →	TD 122 FK	D	126	N 10/260	01.1980 → 12.1989	TD 101 G	D	104
10	01.1987 →	TD 122 FR	D	126	N 10/260	01.1980 → 12.1989	TD 101 G	D	104
10	01.1987 →	TD 122 FS	D	122	N 10/260	01.1980 → 12.1989	TD 101 G	D	104
10	01.1987 →	TD 122 KE	D	126	N 10/260	01.1980 → 12.1989	TD 101 G	D	104
10	09.1988 → 12.1995	TD 102 FDQ	D	104	N 10/260	01.1980 → 12.1989	TD 101 G	D	104
10	1992 → 1995	TD 103 E	D	104	N 10/260	01.1980 → 12.1989	TD 101 G	D	104
10	1992 → 1995	TD 103 EA	D	104	N 10/260	01.1980 → 12.1989	TD 101 G	D	104
12	01.1987 →	TD 122 FK	D	126	N 10/270	01.1973 → 12.1989	TD 100 G	D	106
12	01.1987 →	TD 122 FR	D	126	N 10/270	01.1973 → 12.1989	TD 100 G	D	106
12	01.1987 →	TD 122 FS	D	122	N 10/270	01.1973 → 12.1989	TD 100 G	D	106
12	08.1987 → 12.1994	TD 122 F	D	121	N 10/270	01.1973 → 12.1989	TD 100 G	D	106
12	08.1987 → 12.1994	TD 122 FA	D	126	N 10/270	01.1973 → 12.1989	TD 100 G	D	106
7	11.1991 → 10.1994	TD 73 E	D	75	N 10/270	01.1973 → 12.1989	TD 100 G	D	106
<b>FS7</b>					N 10/270	01.1973 → 12.1989	TD 100 G	D	106
FS 718/230	09.1994 → 03.1996	D7B230	D	74	N 10/270	01.1973 → 12.1989	TD 100 G	D	106
FS 718/260	09.1994 → 03.1996	D7B260	D	74	N 10/270	01.1980 → 12.1989	TD 101 G	D	104
<b>G SERIES</b>					N 10/270	01.1980 → 12.1989	TD 101 G	D	104
88	10.1969 → 12.1971	D 100 B	D	107	N 10/270	01.1980 → 12.1989	TD 101 G	D	104
88 T	08.1965 → 06.1977	TD 100 A	D	108	N 10/270	01.1980 → 12.1989	TD 101 G	D	104
89 T	10.1970 → 06.1977	TD 120 A	D	126	N 10/270	01.1980 → 12.1989	TD 101 G	D	104
<b>L SERIES</b>					N 10/270	01.1980 → 12.1989	TD 101 G	D	104
160		TD 101 KC	D	105	N 10/270	10.1983 → 05.1988	TD 101 G	D	104
160		THD 101 K	D	104	N 10/270	10.1983 → 05.1988	TD 101 G	D	104
180 K	01.1987 →	TD 122 FH	D	135	N 10/270	10.1983 → 05.1988	TD 101 G	D	104
180 K	01.1987 →	TD 122 FL	D	135	N 10/270	10.1983 → 05.1988	TD 101 G	D	104
180 K	01.1987 →	TD 122 GA	D	126	N 10/270	10.1983 → 05.1988	TD 101 G	D	104
180 K	01.1987 →	TD 122 GH	D	126	N 10/270	10.1983 → 05.1988	TD 101 G	D	104
180 K	08.1987 →	TD 122 F	D	121	N 10/270	10.1983 → 05.1988	TD 101 G	D	104
48	01.1963 → 12.1964	TD 70 A	D	72	N 10/270	10.1983 → 05.1988	TD 101 G	D	104
<b>LF SERIES</b>					N 10/290	01.1980 → 12.1989	TD 101 F	D	104
88	01.1965 →	MD 100 B	D	105	N 10/290	01.1980 → 12.1989	TD 101 F	D	104
88	08.1965 →	D 100 A	D	107	N 10/290	01.1980 → 12.1989	TD 101 F	D	104
88	10.1969 →	D 100 B	D	107	N 10/290	01.1980 → 12.1989	TD 101 F	D	104
<b>LN SERIES</b>					N 10/290	01.1980 → 12.1989	TD 101 F	D	104
88	01.1965 →	MD 100 B	D	105	N 10/290	01.1980 → 12.1989	TD 101 F	D	104
88	08.1965 →	D 100 A	D	107	N 10/290	01.1980 → 12.1989	TD 101 F	D	104
88	10.1969 →	D 100 B	D	107	N 10/290	01.1980 → 12.1989	TD 101 F	D	104
<b>N SERIES</b>					N 10/290	01.1980 → 12.1989	TD 101 F	D	104
725	01.1974 → 08.1978	TD 70 E	D	72	N 10/300	01.1973 → 12.1989	TD 100 B	D	104
725	01.1974 →	TD 70 ES	D	71	N 10/300	01.1973 → 12.1989	TD 100 B	D	104
84	01.1965 → 12.1975	TD 50 B	D	61	N 10/300	01.1973 → 12.1989	TD 100 B	D	104
84	10.1965 → 08.1970	D 50 A	D	60	N 10/300	01.1973 → 12.1989	TD 100 B	D	104
84	10.1965 → 12.1975	TD 50 A	D	61	N 10/300	01.1973 → 12.1989	TD 100 B	D	104
84	09.1970 → 12.1971	D 50 B	D	60	N 10/300	01.1973 → 12.1989	TD 100 B	D	104
84	1974 → 1978	TD 60 A	D	66	N 10/300	01.1973 → 12.1989	TD 100 B	D	104
86	10.1965 → 05.1970	D 70 A	D	72	N 10/300	01.1973 → 12.1989	TD 101 GG	D	106
86	10.1965 → 09.1970	TD 70 A	D	72	N 10/300	08.1977 → 04.1985	TD 100 B	D	104
86	06.1970 → 08.1973	D 70 B	D	72	N 10/300	01.1980 → 12.1989	TD 101 F	D	104
86	06.1970 → 12.1974	TMD 70 B	D	72	N 10/300	01.1980 → 12.1989	TD 101 F	D	104
86	08.1970 → 08.1973	TD 70 B	D	72	N 10/300	01.1980 → 12.1989	TD 101 F	D	104
86	08.1970 → 08.1973	TD 70 C	D	72	N 10/300	01.1980 → 12.1989	TD 101 F	D	104
86 T	10.1965 → 05.1970	TD 70 A	D	72	N 10/300	01.1980 → 12.1989	TD 101 F	D	104

V



				Pos					Pos
N 10/300	01.1980 → 12.1996	TD 100 B	D	104	N 12/350	01.1981 → 12.1989	TD 121 FE	D	126
N 10/300	01.1980 → 12.1996	TD 101 F	D	104	N 12/370	01.1981 → 12.1989	TD 121 F	D	122
N 10/300	01.1984 → 12.1998	TD 100 B	D	104	N 12/370	01.1981 → 12.1989	TD 121 F	D	122
N 10/300	01.1984 → 12.1998	TD 101 F	D	104	N 12/370	01.1981 → 12.1989	TD 121 F	D	122
N 10/300	09.1985 → 04.1988	TD 101 F	D	104	N 12/370	01.1981 → 12.1989	TD 121 F	D	122
N 10/300	09.1985 → 12.1989	TD 101 F	D	104	N 12/370	01.1981 → 12.1989	TD 121 F	D	122
N 10/300	09.1985 → 12.1989	TD 101 F	D	104	N 12/370	01.1981 → 12.1989	TD 121 F	D	122
N 10/300	09.1985 → 12.1989	TD 101 F	D	104	N 12/370	01.1981 → 12.1989	TD 121 FF	D	126
N 10/300	09.1985 → 12.1989	TD 101 F	D	104	N 12/370	01.1981 → 12.1989	TD 121 FF	D	126
N 10/300	09.1985 → 12.1989	TD 101 F	D	104	N 12/370	01.1981 → 12.1989	TD 121 FF	D	126
N 10/300	09.1985 → 12.1989	TD 101 F	D	104	N 12/370	01.1981 → 12.1989	TD 121 FF	D	126
N 10/300	09.1985 → 12.1989	TD 101 F	D	104	N 12/385	01.1981 → 12.1989	TD 121 F	D	122
N 10/300	09.1985 → 12.1989	TD 101 F	D	104	N 12/385	01.1981 → 12.1989	TD 121 F	D	122
N 10/300	09.1985 → 12.1989	TD 101 F	D	104	N 12/385	01.1981 → 12.1989	TD 121 F	D	122
N 10/300	09.1985 → 12.1989	TD 101 F	D	104	N 12/385	06.1984 → 09.1991	TD 121 F	D	122
N 10/300	09.1985 → 12.1989	TD 101 F	D	104	N 12/385	01.1985 → 12.1988	TD 121 F	D	122
<b>N12</b>					<b>N7</b>				
12	09.1973 → 03.1984	TD 120 A	D	126	N7	01.1973 → 12.1974	TMD 70 B	D	72
12	1977 → 1981	TAMD 120 A	D	125	N7	10.1974 → 08.1978	TD 70 ES	D	71
12	1977 → 1981	TMD 120 A	D	125	<b>NB SERIES</b>				
12	10.1978 → 03.1984	TD 120 D	D	126	84	01.1972 → 08.1973	D 50 B	D	60
12	10.1978 → 03.1984	TD 120 E	D	126	86	08.1965 → 12.1970	D 70 A	D	72
12	12.1980 → 03.1984	TD 100 G	D	106	86	06.1970 → 08.1973	D 70 B	D	72
12	12.1980 → 03.1984	TD 100 GA	D	106	86 T	08.1970 → 08.1973	TD 70 B	D	72
12	12.1980 → 03.1984	TD 120 GA	D	126	88	08.1965 → 10.1969	D 100 A	D	107
12	08.1982 → 03.1984	TD 120 G	D	126	88 TS	01.1970 → 08.1973	TD 100 A	D	108
12	05.1983 → 05.1986	TD 100 A	D	108	<b>NH12</b>				
12	05.1983 → 05.1986	TD 120 FA	D	126	12-380	07.1999 →	D12C380	D	137
12	05.1983 → 05.1986	TD 120 FB	D	126	12-460	07.1999 →	D12C460	D	137
12	09.1983 → 09.1994	TD 121 GD	D	122	NH 12/340	05.1999 →	D12C340	D	137
12	1984 → 1988	TMD 121 C	D	125	NH 12/340	10.2003 → 12.2006	D12C340	D	137
12	06.1984 → 09.1991	TD 121 FD	D	126	NH 12/380	01.1998 → 09.2003	D12A380	D	136
12	06.1984 → 01.1996	TD 121 G	D	122	NH 12/380	05.1998 → 09.2003	D12C380	D	137
12	01.1986 → 01.1998	TD 121 FA	D	126	NH 12/380	05.1999 →	D12C380	D	137
12	01.1986 → 01.1998	TD 121 FB	D	126	NH 12/380	05.1999 →	D12C380	D	137
12	01.1986 → 01.1998	TD 121 FC	D	126	NH 12/380	05.1999 →	D12C380	D	137
12	01.1986 → 01.1998	TD 121 FE	D	126	NH 12/380	05.1999 →	D12C380	D	137
12	01.1986 → 01.1998	TD 121 FF	D	126	NH 12/380	05.1999 →	D12C380	D	137
12	01.1986 → 01.1998	TD 121 FG	D	126	NH 12/380	05.1999 →	D12C380	D	137
12	07.1986 → 01.1998	TD 121 A	D	126	NH 12/380	05.1999 →	D12C380	D	137
12	09.1986 → 01.1996	TD 121 F	D	122	NH 12/380	10.2003 → 12.2006	D12C380	D	137
N 12/290	01.1981 → 12.1989	TD 120 FA	D	126	NH 12/380	01.1997 →	D12A420	D	136
N 12/290	01.1981 → 12.1989	TD 120 FA	D	126	NH 12/420	01.1997 →	D12A420	D	136
N 12/290	01.1981 → 12.1989	TD 120 FA	D	126	NH 12/420	01.1997 →	D12C420	D	138
N 12/290	01.1981 → 12.1989	TD 121 G	D	122	NH 12/420	01.1997 →	D12C420	D	138
N 12/290	01.1981 → 12.1989	TD 121 G	D	122	NH 12/420	05.1999 → 09.2003	D12C420	D	138
N 12/290	01.1981 → 12.1989	TD 121 G	D	122	NH 12/420	05.1999 → 09.2003	D12C420	D	138
N 12/290	01.1981 → 12.1989	TD 121 G	D	122	NH 12/420	05.1999 → 09.2003	D12C420	D	138
N 12/290	01.1981 → 12.1989	TD 121 G	D	122	NH 12/420	09.2000 →	D12C420	D	138
N 12/290	01.1981 → 12.1989	TD 121 G	D	122	NH 12/420	09.2000 →	D12C420	D	138
N 12/310	01.1981 → 12.1989	TD 120 FB	D	126	NH 12/420	09.2000 →	D12C420	D	138
N 12/310	01.1981 → 12.1989	TD 120 FB	D	126	NH 12/460	01.1997 →	D12C460	D	137
N 12/310	01.1981 → 12.1989	TD 120 FB	D	126	NH 12/460	01.1997 →	D12C460	D	137
N 12/310	01.1981 → 12.1989	TD 120 FB	D	126	NH 12/460	01.1997 →	D12C460	D	137
N 12/310	01.1981 → 12.1989	TD 120 GA	D	126	NH 12/460	05.1999 →	D12C460	D	137
N 12/310	01.1981 → 12.1989	TD 120 GA	D	126	NH 12/460	05.1999 →	D12C460	D	137
N 12/310	01.1981 → 12.1989	TD 120 GA	D	126	NH 12/460	05.1999 →	D12C460	D	137
N 12/310	01.1981 → 12.1989	TD 120 GA	D	126	NH 12/460	01.2004 → 12.2006	D12C460	D	137
N 12/310	01.1981 → 12.1989	TD 120 GA	D	126	NH 12/460	01.2004 → 12.2006	D12C460	D	137
N 12/310	01.1981 → 12.1989	TD 120 GA	D	126	NH 12/460	01.2004 → 12.2006	D12C460	D	137
N 12/310	01.1981 → 12.1989	TD 120 GA	D	126	NH 12/460	01.2004 → 12.2006	D12C460	D	137
N 12/330	01.1981 → 12.1983	TD 121 G	D	122	<b>NL</b>				
N 12/330	01.1981 → 12.1989	TD 121 G	D	122	10	05.1991 → 08.1991	TD 100 G	D	106
N 12/330	01.1981 → 12.1989	TD 121 G	D	122	10	05.1991 → 09.2001	TD 101 G	D	104
N 12/330	01.1981 → 12.1989	TD 121 G	D	122	10	05.1991 → 09.2001	TD 102 F	D	104
N 12/330	01.1981 → 12.1989	TD 121 G	D	122	10	05.1991 → 09.2001	TD 102 FH	D	104
N 12/330	06.1984 → 09.1991	TD 121 G	D	122	10	05.1991 → 09.2001	TD 102 FL	D	104
N 12/350	01.1981 → 12.1989	TD 121 FC	D	126	10	05.1991 → 09.2001	TD 103 ES	D	104
N 12/350	01.1981 → 12.1989	TD 121 FC	D	126	10	05.1991 →	TD 100 F	D	104
N 12/350	01.1981 → 12.1989	TD 121 FC	D	126	10	05.1991 →	TD 101 FA	D	104
N 12/350	01.1981 → 12.1989	TD 121 FC	D	126	10	05.1991 →	TD 101 FD	D	104
N 12/350	01.1981 → 12.1989	TD 121 FE	D	126	10	05.1991 →	TD 101 GG	D	106
N 12/350	01.1981 → 12.1989	TD 121 FE	D	126	10	05.1991 →	TD 102 FDQ	D	104
N 12/350	01.1981 → 12.1989	TD 121 FE	D	126	10	05.1991 →	TD 102 FQ	D	104







				Pos					Pos
10	05.1991 →	TD 102 FS	D	105	NL 12/400	01.1989 → 12.1995	TD 122 FS	D	122
10	1992 → 1995	TD 103 EA	D	104	NL 12/400	01.1989 → 12.1995	TD 122 FS	D	122
10	12.1992 →	TD 102 FT	D	105	NL 12/400	01.1989 → 12.1995	TD 122 FS	D	122
10	01.1996 →	D10A320	D	109	NL 12/400	01.1989 → 12.1995	TD 122 FS	D	122
12	10.1989 → 09.2001	TD 121 F	D	122	NL 12/400	01.1989 → 12.1995	TD 122 FS	D	122
12	05.1991 → 09.2001	TD 121 G	D	122	NL 12/400	01.1989 → 12.1995	TD 122 FS	D	122
12	05.1991 → 09.2001	TD 122 F	D	121	NL 12/410	01.1990 →	TD 123 ES	D	135
12	05.1991 → 09.2001	TD 122 FH	D	135	NL 12/410	01.1990 →	TD 123 ES	D	135
12	05.1991 → 09.2001	TD 122 FL	D	135	NL 12/410	12.1992 → 12.1994	TD 123 ES	D	135
12	05.1991 → 09.2001	TD 122 FS	D	122	NL 12/410	01.1995 → 12.1999	TD 123 ES	D	135
12	05.1991 → 09.2001	TD 123 E	D	135	<b>NT</b>				
12	05.1991 → 09.2001	TD 123 ES	D	135	88 T	08.1965 → 12.1969	TD 100 A	D	108
12	12.1992 → 09.2001	TD 122 FR	D	126	88 TS	01.1970 → 08.1973	TD 100 A	D	108
NL 10/260	01.1989 → 12.1992	TD 101 G	D	104	<b>OLYMPIAN</b>				
NL 10/260	01.1989 → 12.1992	TD 101 G	D	104	Olympian	01.1992 → 12.2000	THD 102 KF	D	109
NL 10/260	01.1989 → 12.1992	TD 101 G	D	104	Olympian	07.1997 →	DH10A245	D	109
NL 10/260	01.1989 → 12.1992	TD 101 G	D	104	Olympian	07.1998 →	D 10 A 245	D	109
NL 10/260	01.1989 → 12.1992	TD 101 G	D	104	Olympian	12.2001 →	D9A300	D	94
NL 10/260	01.1989 → 12.1992	TD 101 G	D	104	Olympian	12.2001 →	D9A340	D	94
NL 10/260	01.1989 → 12.1992	TD 101 G	D	104	<b>TF SERIES</b>				
NL 10/260	01.1989 → 12.1992	TD 101 G	D	104	86 DTC	01.1974 → 08.1978	TD 70 E	D	72
NL 10/260	01.1989 → 12.1992	TD 101 G	D	104	86 DTC	01.1974 → 08.1978	TD 70 ES	D	71
NL 10/280	01.1989 → 12.1992	TD 102 FS	D	105	86 T	01.1974 → 08.1978	TD 70 E	D	72
NL 10/310	01.1990 →	TD 102 F	D	104	86 T	01.1974 → 08.1978	TD 70 ES	D	71
NL 10/310	01.1990 →	TD 102 FT	D	105	<b>VA</b>				
NL 10/320	01.1990 →	D10A320	D	109	VAH 200-325	08.2016 →	D11-325	D	117
NL 10/320	01.1990 →	D10A320	D	109	VAH 200-355	08.2016 →	D11-355	D	117
NL 10/320	01.1990 →	TD 102 FL	D	104	VAH 200-365	08.2016 →	D11-365	D	117
NL 10/320	01.1990 →	TD 102 FL	D	104	VAH 200-380	08.2016 →	D13C380	D	157
NL 10/320	01.1990 →	TD 103 ES	D	104	VAH 200-385	08.2016 →	D11-385	D	117
NL 10/320	01.1990 →	TD 103 ES	D	104	VAH 200-420	08.2016 →	D13C420	D	157
NL 10/320	01.1996 → 12.1999	D10A320	D	109	VAH 200-460	08.2016 →	D13C460	D	150
NL 10/320	01.1996 → 12.1999	D10A320	D	109	VAH 200-500	08.2016 →	D13C500	D	151
NL 10/340	01.1989 → 12.1994	TD 102 FS	D	105	VAH 430-325	08.2016 →	D11-325	D	117
NL 10/340	01.1990 →	TD 102 FS	D	105	VAH 430-355	08.2016 →	D11-355	D	117
NL 12/290	01.1989 → 12.1992	TD 121 G	D	122	VAH 430-365	08.2016 →	D11-365	D	117
NL 12/290	01.1989 → 12.1992	TD 121 G	D	122	VAH 430-380	08.2016 →	D13C380	D	157
NL 12/290	01.1989 → 12.1992	TD 121 G	D	122	VAH 430-385	08.2016 →	D11-385	D	117
NL 12/290	01.1989 → 12.1992	TD 121 G	D	122	VAH 430-420	08.2016 →	D13C420	D	157
NL 12/290	01.1989 → 12.1992	TD 121 G	D	122	VAH 430-460	08.2016 →	D13C460	D	150
NL 12/290	01.1989 → 12.1992	TD 121 G	D	122	VAH 430-500	08.2016 →	D13C500	D	151
NL 12/290	01.1989 → 12.1992	TD 121 G	D	122	VAH 630-325	08.2016 →	D11-325	D	117
NL 12/290	01.1989 → 12.1992	TD 121 G	D	122	VAH 630-355	08.2016 →	D11-355	D	117
NL 12/290	01.1989 → 12.1992	TD 121 G	D	122	VAH 630-365	08.2016 →	D11-365	D	117
NL 12/360	01.1990 →	TD 122 F	D	121	VAH 630-380	08.2016 →	D13C380	D	157
NL 12/360	01.1990 →	TD 122 FR	D	126	VAH 630-385	08.2016 →	D11-385	D	117
NL 12/360	01.1990 →	TD 123 E	D	135	VAH 630-420	08.2016 →	D13C420	D	157
NL 12/360	01.1990 →	TD 123 E	D	135	VAH 630-460	08.2016 →	D13C460	D	150
NL 12/360	01.1992 → 12.1995	TD 122 F	D	121	VAH 630-500	08.2016 →	D13C500	D	151
NL 12/360	01.1992 → 12.1995	TD 122 F	D	121	<b>VH</b>				
NL 12/360	01.1992 → 12.1995	TD 122 F	D	121	VHD 200-325	08.2016 →	D11-325	D	117
NL 12/360	01.1992 → 12.1995	TD 122 F	D	121	VHD 200-325	08.2016 →	D11-325	D	117
NL 12/360	01.1992 → 12.1995	TD 122 F	D	121	VHD 200-325	08.2016 →	D11-325	D	117
NL 12/360	01.1992 → 12.1995	TD 122 FR	D	126	VHD 200-325	08.2016 →	D11-325	D	117
NL 12/360	01.1992 → 12.1995	TD 122 FR	D	126	VHD 200-355	08.2016 →	D11-355	D	117
NL 12/360	01.1992 → 12.1995	TD 122 FR	D	126	VHD 200-355	08.2016 →	D11-355	D	117
NL 12/360	01.1992 → 12.1995	TD 122 FR	D	126	VHD 200-355	08.2016 →	D11-355	D	117
NL 12/360	01.1992 → 12.1995	TD 122 FR	D	126	VHD 200-355	08.2016 →	D11-355	D	117
NL 12/360	01.1992 → 12.1994	TD 122 F	D	121	VHD 200-365	08.2016 →	D11-365	D	117
NL 12/360	12.1992 → 12.1994	TD 122 FR	D	126	VHD 200-365	08.2016 →	D11-365	D	117
NL 12/360	01.1995 → 12.1999	TD 122 F	D	121	VHD 200-365	08.2016 →	D11-365	D	117
NL 12/360	01.1995 → 12.1999	TD 122 F	D	121	VHD 200-365	08.2016 →	D11-365	D	117
NL 12/360	01.1995 → 12.1999	TD 122 FR	D	126	VHD 200-380	08.2016 →	D13C380	D	157
NL 12/360	01.1995 → 12.1999	TD 122 FR	D	126	VHD 200-380	08.2016 →	D13C380	D	157
NL 12/360	01.1995 → 12.1999	TD 123 E	D	135	VHD 200-380	08.2016 →	D13C380	D	157
NL 12/360	01.1995 → 12.1999	TD 123 E	D	135	VHD 200-380	08.2016 →	D13C380	D	157
NL 12/400	01.1989 → 12.1995	TD 122 FS	D	122	VHD 200-385	08.2016 →	D11-385	D	117
NL 12/400	01.1989 → 12.1995	TD 122 FS	D	122	VHD 200-385	08.2016 →	D11-385	D	117
NL 12/400	01.1989 → 12.1995	TD 122 FS	D	122	VHD 200-385	08.2016 →	D11-385	D	117

V



				Pos					Pos
VHD 200-385	08.2016 →	D11-385	D	117	VNL 730-420	08.2016 →	D13C420	D	157
VHD 200-420	08.2016 →	D13C420	D	157	VNL 730-460	08.2016 →	D13C460	D	150
VHD 200-420	08.2016 →	D13C420	D	157	VNL 730-500	08.2016 →	D13C500	D	151
VHD 200-420	08.2016 →	D13C420	D	157	VNL 780-380	08.2016 →	D13C380	D	157
VHD 200-420	08.2016 →	D13C420	D	157	VNL 780-420	08.2016 →	D13C420	D	157
VHD 200-460	08.2016 →	D13C460	D	150	VNL 780-460	08.2016 →	D13C460	D	150
VHD 200-460	08.2016 →	D13C460	D	150	VNL 780-500	08.2016 →	D13C500	D	151
VHD 200-460	08.2016 →	D13C460	D	150	<b>VNM</b>				
VHD 200-460	08.2016 →	D13C460	D	150	VNM 200-325	08.2016 →	D11-325	D	117
VHD 200-500	08.2016 →	D13C500	D	151	VNM 200-355	08.2016 →	D11-355	D	117
VHD 200-500	08.2016 →	D13C500	D	151	VNM 200-365	08.2016 →	D11-365	D	117
VHD 200-500	08.2016 →	D13C500	D	151	VNM 200-380	08.2016 →	D13C380	D	157
VHD 200-500	08.2016 →	D13C500	D	151	VNM 200-385	08.2016 →	D11-385	D	117
VHD 430-325	08.2016 →	D11-325	D	117	VNM 200-420	08.2016 →	D13C420	D	157
VHD 430-325	08.2016 →	D11-325	D	117	VNM 200-460	08.2016 →	D13C460	D	150
VHD 430-325	08.2016 →	D11-325	D	117	VNM 200-500	08.2016 →	D13C500	D	151
VHD 430-355	08.2016 →	D11-355	D	117	VNM 430-325	08.2016 →	D11-325	D	117
VHD 430-355	08.2016 →	D11-355	D	117	VNM 430-355	08.2016 →	D11-355	D	117
VHD 430-355	08.2016 →	D11-355	D	117	VNM 430-365	08.2016 →	D11-365	D	117
VHD 430-365	08.2016 →	D11-365	D	117	VNM 430-380	08.2016 →	D13C380	D	157
VHD 430-365	08.2016 →	D11-365	D	117	VNM 430-420	08.2016 →	D13C420	D	157
VHD 430-365	08.2016 →	D11-365	D	117	VNM 430-460	08.2016 →	D13C460	D	150
VHD 430-380	08.2016 →	D13C380	D	157	VNM 430-500	08.2016 →	D13C500	D	151
VHD 430-380	08.2016 →	D13C380	D	157	VNM 630-325	08.2016 →	D11-325	D	117
VHD 430-380	08.2016 →	D13C380	D	157	VNM 630-355	08.2016 →	D11-355	D	117
VHD 430-385	08.2016 →	D11-385	D	117	VNM 630-360	08.2016 →	D13A360	D	152
VHD 430-385	08.2016 →	D11-385	D	117	VNM 630-365	08.2016 →	D11-365	D	117
VHD 430-385	08.2016 →	D11-385	D	117	VNM 630-380	08.2016 →	D13C380	D	157
VHD 430-420	08.2016 →	D13C420	D	157	VNM 630-385	08.2016 →	D11-385	D	117
VHD 430-420	08.2016 →	D13C420	D	157	VNM 630-400	08.2016 →	D13A400	D	153
VHD 430-420	08.2016 →	D13C420	D	157	VNM 630-420	08.2016 →	D13C420	D	157
VHD 430-460	08.2016 →	D13C460	D	150	VNM 630-430	08.2016 →	D11A430	D	113
VHD 430-460	08.2016 →	D13C460	D	150	VNM 630-440	08.2016 →	D13A440	D	152
VHD 430-460	08.2016 →	D13C460	D	150	VNM 630-460	08.2016 →	D13C420	D	157
VHD 430-500	08.2016 →	D13C500	D	151	VNM 630-480	08.2016 →	D13A480	D	152
VHD 430-500	08.2016 →	D13C500	D	151	VNM 630-500	08.2016 →	D13C500	D	151
VHD 430-500	08.2016 →	D13C500	D	151	VNM 630-520	08.2016 →	D13A520	D	152
<b>VLE</b>					<b>VT</b>				
VLE	01.2009 → 12.2010	D7E 240	D	88	VT 880- 520	01.2005 → 12.2007	D16A520	D	173
VLE	01.2009 → 12.2010	D7E 280	D	88	VT 880- 550	01.2005 → 12.2007	D16C550	D	177
VLE	01.2009 → 12.2010	D7E 320	D	88	VT 880- 610	01.2005 → 12.2007	D16C610	D	177
VLE	01.2011 → 12.2014	D7E 240	D	88	<b>WHITE GMC (USA)</b>				
VLE	01.2011 → 12.2014	D7E 280	D	88	White GMC (USA)		TD 122 F	D	121
VLE	01.2011 → 12.2014	D7E 320	D	88	White GMC (USA)		TD 122 FH	D	135
VLE	01.2011 → 12.2014	D7E 320	D	88	White GMC (USA)		TD 122 FL	D	135
<b>VNL</b>									
VNL 300-325	08.2016 →	D11-325	D	117	<b>FE</b>				
VNL 300-355	08.2016 →	D11-355	D	117	FE 240-18	05.2006 →	D7E 240	D	88
VNL 300-365	08.2016 →	D11-365	D	117	FE 280-18	05.2006 →	D7E 280	D	88
VNL 300-380	08.2016 →	D13C380	D	157	FE 280-26	05.2006 →	D7E 280	D	88
VNL 300-385	08.2016 →	D11-385	D	117	FE 320-18	05.2006 →	D7E 320	D	88
VNL 300-420	08.2016 →	D13C420	D	157	FE 320-26	05.2006 →	D7E 320	D	88
VNL 300-460	08.2016 →	D13C460	D	150	<b>FE II</b>				
VNL 300-500	08.2016 →	D13C500	D	151	FE 240-18	05.2012 →	D7E 240	D	88
VNL 430-325	08.2016 →	D11-325	D	117	FE 280-18	05.2012 →	D7E 280	D	88
VNL 430-355	08.2016 →	D11-355	D	117	FE 280-26	05.2012 →	D7E 280	D	88
VNL 430-365	08.2016 →	D11-365	D	117	FE 320-18	05.2012 →	D7E 320	D	88
VNL 430-380	08.2016 →	D13C380	D	157	FE 320-26	05.2012 →	D7E 320	D	88
VNL 430-420	08.2016 →	D13C420	D	157	<b>FL II</b>				
VNL 430-460	08.2016 →	D13C460	D	150	FL 240-15	05.2006 →	D7E 240	D	88
VNL 430-500	08.2016 →	D13C500	D	151	FL 240-16	06.2009 →	D7E 240	D	88
VNL 630-380	08.2016 →	D13C380	D	157	FL 280-15	05.2006 →	D7E 280	D	88
VNL 630-420	08.2016 →	D13C420	D	157	<b>FL III</b>				
VNL 630-460	08.2016 →	D13C460	D	150	FL 240-12	05.2013 →	D5K240	D	91
VNL 630-500	08.2016 →	D13C500	D	151	FL 240-15	05.2013 →	D7E 240	D	88
VNL 670-380	08.2016 →	D13C380	D	157	FL 240-16	05.2013 →	D7E 240	D	88
VNL 670-420	08.2016 →	D13C420	D	157	FL 250-16	05.2013 →	D8K250	D	91
VNL 670-460	08.2016 →	D13C460	D	150	<b>FL10</b>				
VNL 670-500	08.2016 →	D13C500	D	151					
VNL 730-380	08.2016 →	D13C380	D	157					

V

				Pos				Pos
FL 10/310	09.1985 → 02.1996	TD 102 FM	D	104				
<b>FM</b>								
FM 420	02.2017 →	D13A420	D	154				
<b>FMX II</b>								
460	04.2018 →	D13A460	D	154				

V

					Reference	Item No.		
<b>1</b>		<b>70</b>						
<b>B 10</b>	<b>E</b>	08.1975 → 08.1978	B (NA)	4	1108 cm <sup>3</sup> 2V	33-35 kW (45-48 PS) 8,5:1 72,00 mm		
	[50]	∅ 7 mm				3104400 3104400-1 3101039 3101039-0	<b>KK-7H</b> <b>MK-7H2</b>	
	[50]	∅ 7 mm						
	IN/EX [4]	11,14 x 7 x 41,5	G1			3102891	<b>81-5115</b>	
<b>2</b>		<b>73</b>						
<b>B 13</b>		01.1989 → 12.1990	B (NA)	4	1289 cm <sup>3</sup> 2V	49 kW (66 PS) 8,5:1 76,50 mm		
<b>B 130</b>		08.1975 → 11.1979	B (NA)	4	1289 cm <sup>3</sup> 2V	42 kW (57 PS) 9,6 76,50 mm		
	[50]	∅ 7 mm				3104400 3104400-1 3101039 3101039-0	<b>KK-7H</b> <b>MK-7H2</b>	
	[50]	∅ 7 mm						
	IN/EX [4]	11,14 x 7 x 41,5	G1			3102891	<b>81-5115</b>	
<b>3</b>		<b>75</b>						
<b>D 4164</b>	<b>T</b>	01.2005 → 12.2012	D (LA)	4	1560 cm <sup>3</sup> 4V	80-81 kW (109-110 PS) 18,3 88,30 mm		
40 179 6..								
	IN [2] EX [2]	25,6 x 5,5 x 96,4 23,4 x 5,5 x 96,6	S - Cr - A/S - Cr -	- 45° - - 45° -	- VS -	22 - III 22 - III	30711498 30711497	<b>539009</b> <b>539010</b>
	[50]	∅ 5,5 mm					<b>MK-5.5H</b>	
	IN/EX [4]	9,55 x 5.51 x 34,0	G1				<b>81-18111</b> <b>NEW</b>	
		ES AS ES AS					<b>50 007 093</b> <b>NEW</b> (1) <b>50 007 094</b> <b>NEW</b> (1) <b>50 007 573</b> (2) <b>50 007 574</b> (2)	
	(1)	gegossene Version / cast Version / version coule / versión fundida / литая версия						
	(2)	(ST)						
	[8]	H 12 x 34,5 x 33,4				30711499	<b>50 006 433</b>	
	[4]						<b>50 006 485</b>	
<b>4</b>		<b>75</b>						
<b>D 4162</b>	<b>T</b>	01.2010 →	D (A)	4	1560 cm <sup>3</sup> 2V	84 kW (114 PS) 16 88,30 mm		
41 253 6..								
	IN [2] EX [2]	30,0 x 5,5 x 95,5 27,6 x 5,5 x 95,5	S - Cr - RA/S- Cr -	- 45° - - 45° -	- VS -	22 - III 22 - III	31330181 31330182	<b>539046</b> <b>NEW</b> <b>539047</b> <b>NEW</b>
	[50]	∅ 5,5 mm					<b>MK-5.5H</b>	
	IN/EX [4]	9,55 x 5.51 x 34,0	G1				<b>81-18111</b> <b>NEW</b>	
Fortsetzung nächste Seite / continued on next page / suite page suivante / continuación página próxima / Продолжение на следующей странице								

V

					Reference	Item No.
[8]	H 12 x 34,6 x 34,6					50 006 432
<b>5</b>	<b>76</b>					
<b>B 14</b>	<b>OE</b> 02.1976 → 07.1979	B (NA)	4	1397 cm <sup>3</sup>	2V 51 kW (69 PS)	9,3:1 77,00 mm
<b>B 14.3</b>	<b>E</b> 08.1979 → 12.1986	B (NA)	4	1397 cm <sup>3</sup>	2V 46-53 kW (63-72 PS)	9,2 77,00 mm
<b>B 14.4</b>	<b>S</b> 01.1976 → 12.1988	B (NA)	4	1397 cm <sup>3</sup>	2V 50-53 kW (68-72 PS)	9,25 77,00 mm
93 696 6..						
[50]	∅ 7 mm				3104400 3104400-1	<b>KK-7H</b>
[50]	∅ 7 mm				3101039 3101039-0	<b>MK-7H2</b>
IN/EX [4]	11,14 x 7 x 41,5	G1			3102891	<b>81-5115</b>
<b>6</b>	<b>76,5</b>					
<b>D 24</b>	01.1979 → 07.1995	D (NA)	6	2383 cm <sup>3</sup>	2V 58-61 kW (79-83 PS)	23,5 86,40 mm
93 260 6..						
IN [2]	36,0 x 8 x 104,9	A/S - -	- 45° - -	22 - III	1328147 1328147-2 13281472	<b>33044</b>
EX [2]	31,0 x 8 x 104,7	A/S - -	- 45° - -	22 - III		<b>331101</b>
[50]	∅ 8 mm				20510747 419643	<b>MK-8H</b>
[50]	∅ 8 mm				465284	<b>RK-8</b>
IN/EX [4]	12,06/15 x 8 x 36,5	B1			1257613	<b>81-3310</b>
IN/EX [4]	12,13/15 x 8 x 36,5	B1				<b>81-3312</b>
IN/EX [4]	12,20/15 x 8 x 36,5	B1				<b>81-3311</b>
<b>7</b>	<b>76,5</b>					
<b>D 24</b>	<b>TIC</b> 04.1986 → 10.1998	D (LA)	6	2383 cm <sup>3</sup>	2V 85-95 kW (115-130 PS)	23 86,40 mm
<b>D 24</b>	<b>T</b> 08.1982 → 12.1994	D (A)	6	2383 cm <sup>3</sup>	2V 79-83 kW (107-113 PS)	23 86,40 mm
90 732 6..						
IN [2]	36,0 x 8 x 104,9	A/S - -	- 45° - -	22 - III	1328147 1328147-2 13281472	<b>33044</b>
EX [2]	31,0 x 8 x 104,7	A/S - -	- 45° - -	22 - III		<b>331101</b>
[50]	∅ 8 mm				20510747 419643	<b>MK-8H</b>
IN/EX [4]	12,06/15 x 8 x 36,5	B1			1257613	<b>81-3310</b>
IN/EX [4]	12,13/15 x 8 x 36,5	B1				<b>81-3312</b>
IN/EX [4]	12,20/15 x 8 x 36,5	B1				<b>81-3311</b>
<b>8</b>	<b>78</b>					
<b>D 16</b>	08.1984 → 07.1991	D (NA)	4	1596 cm <sup>3</sup>	2V 40 kW (54 PS)	22,5 83,60 mm
90 468 8..						
[50]	∅ 8 mm				8420816 8420816-4	<b>KK-8H</b>
<b>9</b>	<b>79</b>					
<b>B 4164</b>	<b>S3</b> 01.2005 → 12.2012	B (NA)	4	1596 cm <sup>3</sup>	4V 74 kW (101 PS)	10,5 81,40 mm
Fortsetzung nächste Seite / continued on next page / suite page suivante / continuación página próxima / Продолжение на следующей странице						

					Reference	Item No.
IN [2] EX [2]	30,1 x 6 x 99,0 24,1 x 6 x 101,4	S - Ni - RA - Ni -	- 45° - - - 45° - -	22 - 22 -	30711639 30711638	<b>181106</b> <b>181107</b>
[50]	Ø 6 mm					<b>MK-6H</b>
IN/EX [6] IN/EX [4]	11,99 x 7 x 45,0 11,04 x 6.01 x 40,5	G1 G1			1270391	<b>81-47105</b> <b>81-71003</b>
<b>10</b>	<b>79</b>	<b>B 4164 Euro 5 T4</b> 03.2013 → 12.2015 B (LA) 4 1596 cm³ 4V 88 kW (120 PS) 10 81,40 mm 40 883 6..				
IN/EX [1]	9,53 x 5 x 36,0	B1				<b>81-18113</b> <small>NEW</small>
<b>11</b>	<b>79</b>	<b>B 4164 Euro 5 T2</b> 01.2011 → 12.2015 AB (LA) 4 1596 cm³ 4V 132 kW (180 PS) 10 81,40 mm 40 883 6..				
IN/EX [1]	9,53 x 5 x 36,0	B1				<b>81-18113</b> <small>NEW</small>
<b>12</b>	<b>80</b>	<b>D 4192 T</b> 09.1996 → 08.1999 D (A) 4 1870 cm³ 2V 66 kW (90 PS) 20,5 93,00 mm 94 357 6..				
[50]	Ø 8 mm				8420816 8420816-4	<b>KK-8H</b>
<b>13</b>	<b>80</b>	<b>D 4192 T2, T3, T4</b> 01.2000 → 06.2004 D (A) 4 1870 cm³ 2V 70-85 kW (95-116 PS) 19 93,00 mm				
IN [2] EX [2]	35,3 x 7 x 110,9 32,6 x 7 x 110,7	S - - A/S - -	- 45° - - - 45° - -	1 - III 1 - III		<b>511013</b> <b>511014</b>
[50]	Ø 7 mm				3104400 3104400-1	<b>KK-7H</b>
IN/EX [4]	12,06 x 7 x 38,3	B1				<b>81-5135</b>
<b>14</b>	<b>81</b>	<b>B 18 E</b> 08.1986 → 07.1992 B (NA) 4 1721 cm³ 2V 78-80 kW (106-109 PS) 9,5 83,50 mm				
EX [2]	32,5 x 8 x 111,3	A/S - -	- 45° - VS -	1 - III	3342399 3342399-7 33423997 3343738 3343738-5 33437385	<b>517981</b>
[50]	Ø 7 mm				3104400 3104400-1	<b>KK-7H</b>
[50]	Ø 8 mm				8420816 8420816-4	<b>KK-8H</b>
IN/EX [4] EX [4]	13,07 x 8 x 37,7 13,14 x 8 x 49,0	B1 G1			3343624	<b>81-47103</b> <b>81-5117</b>













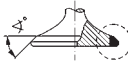



V

					Reference	Item No.		
<b>15</b>	81							
<b>B 18</b>	<b>FT</b>							
	08.1987 → 12.1996	B (A)	4	1721 cm <sup>3</sup>	2V	88-90 kW (120-122 PS)	8	83,50 mm
<b>B 18</b>	<b>EP, F</b>							
	08.1987 → 12.1996	B (NA)	4	1721 cm <sup>3</sup>	2V	70-80 kW (95-109 PS)		83,50 mm
	EX [2]	32,5 x 8 x 111,3	A/S - -	- 45° - VS -	1 - III	3342399 3342399-7 33423997 3343738 3343738-5 33437385		<b>517981</b>
	[50]	∅ 7 mm				3104400 3104400-1		<b>KK-7H</b>
	[50]	∅ 8 mm				8420816 8420816-4		<b>KK-8H</b>
	IN/EX [4]	13,07 x 8 x 37,7	B1			3343624		<b>81-47103</b>
<b>16</b>	81							
<b>B 4164</b>	<b>S</b>							
	09.1995 → 08.1999	B (NA)	4	1587 cm <sup>3</sup>	4V	77 kW (105 PS)	10,5	77,00 mm
<b>B 4164</b>	<b>S2</b>							
	01.2000 → 06.2004	B (A)	4	1587 cm <sup>3</sup>	4V	80 kW (109 PS)	10,3	77,00 mm
<b>B 4184</b>	<b>SJ, SM</b>							
	03.1998 → 06.2004	B (NA)	4	1834 cm <sup>3</sup>	4V	90-92 kW (122-125 PS)		89,00 mm
<b>B 5204</b>	<b>T3</b>							
	01.1997 → 07.2006	B (LA)	5	1984 cm <sup>3</sup>	4V	166 kW (226 PS)	8,4	77,00 mm
<b>B 5204</b>	<b>T, T2, T4</b>							
	08.1993 → 07.2006	B (A)	5	1984 cm <sup>3</sup>	4V	120-155 kW (163-211 PS)		77,00 mm
<b>B 5234</b>	<b>T3</b>							
	11.1996 → 04.2010	B (LA)	5	2319 cm <sup>3</sup>	4V	147-184 kW (239-250 PS)	8,5	90,00 mm
<b>B 5234</b>	<b>T1, T2, T6, T7</b>							
		B (A)	5	2319 cm <sup>3</sup>	4V	166-195 kW (226-265 PS)		90,00 mm
<b>B 6254</b>	<b>F, S</b>							
		B (NA)	6	2473 cm <sup>3</sup>	4V	125 kW (170 PS)		80,00 mm
	IN [2]	31,0 x 7 x 104,1	S - Cr -	- 45° - -	22 - III	1397641 1397641-0 13976410 9207874		<b>47145</b>
	EX [2]	27,0 x 7 x 103,3	A/S - Cr -	- 45° - VS -	22 - III	1366490 1366882 1366882-7 13668827 9207880 9207977 9471463 9471466		<b>47130</b>
	[50]	∅ 7 mm						<b>MK-7H</b>
	IN/EX [6]	11,99 x 7 x 45,0	G1			1270391		<b>81-47105</b>
	[8]	H 32 x 26				1275353 1366842 9207830		<b>50 007 605</b>



					Reference	Item No.	
<b>17</b>		<b>81</b>					
<b>B 4194</b>	<b>T, T2</b>	05.1997 → 07.2000	B (A) 4	1855 cm <sup>3</sup> 4V	147 kW (200 PS)	8,5 90,00 mm	
<b>B 5204</b>	<b>S</b>	01.1996 →	B (NA) 5	1984 cm <sup>3</sup> 4V	93-105 kW (126-143 PS)	10,3:1 77,00 mm	
<b>B 5234</b>	<b>T5, T8, T9</b>	09.1994 → 10.2005	B (A) 5	2319 cm <sup>3</sup> 4V	177-195 kW (241-265 PS)	8,5 90,00 mm	
<b>B 5234</b>	<b>S</b>		B	5 2319 cm <sup>3</sup> 4V	120 kW (163 PS)	10,5:1 90,00 mm	
<b>B 6254</b>	<b>G</b>		B (NA) 6	2473 cm <sup>3</sup> 4V	125 kW (170 PS)	10,5:1 80,00 mm	
	IN [2]	31,0 x 7 x 104,1	S - Cr -	- 45° - -	22 - III	1397641 1397641-0 13976410 9207874	<b>47145</b>
	EX [2]	27,0 x 7 x 103,3	A/S - Cr -	- 45° - VS -	22 - III	1366490 1366882 1366882-7 13668827 9207880 9207977 9471463 9471466	<b>47130</b>
	[50]	Ø 7 mm					<b>MK-7H</b>
	IN/EX [6]	11,99 x 7 x 45,0	G1			1270391	<b>81-47105</b>
<b>18</b>		<b>81</b>					
<b>B 5202</b>	<b>S</b>	08.1994 → 11.2000	B (NA) 5	1984 cm <sup>3</sup> 2V	93 kW (126 PS)	10 77,00 mm	
	[50]	Ø 7 mm					<b>MK-7H</b>
<b>19</b>		<b>81</b>					
<b>B 5234</b>	<b>T4</b>	08.1995 → 11.2000	B (LA) 5	2319 cm <sup>3</sup> 4V	176-184 kW (239-250 PS)	8,5 90,00 mm	
	[8]	H 32 x 26				1275353 1366842 9207830	<b>50 007 605</b>
<b>20</b>		<b>81</b>					
<b>B 6284</b>	<b>T</b>	05.1998 → 12.2001	B (LA) 6	2783 cm <sup>3</sup> 4V	200 kW (272 PS)	8,5 90,00 mm	
	IN [2]	31,0 x 6 x 104,3	S - Cr -	- 45° - -	22 - III	9454607	<b>471206</b>
	IN [2]	32,0 x 6 x 104,3	S - Ni -	- 45° - -	22 - III	9454608	<b>471207</b>
	EX [2]	27,0 x 6 x 103,3	RA/S- Ni -	- 45° - VS -	22 - III	9454609 9454610	<b>471209</b>
	[50]	Ø 6 mm					<b>MK-6H</b>
	[8]	H 32 x 26				1275353 1366842 9207830	<b>50 007 605</b>
<b>21</b>		<b>81</b>					
<b>B 5204</b>	<b>T5</b>	11.1999 → 04.2010	B (A) 5	1984 cm <sup>3</sup> 4V	132 kW (180 PS)	9,5 77,00 mm	
Fortsetzung nächste Seite / continued on next page / suite page suivante / continuación página próxima / Продолжение на следующей странице							

V

					Reference	Item No.	
	IN [2]	31,0 x 6 x 104,3	S - Cr -	- 45° - -	22 - III	9454607	<b>471206</b> <small>NEW</small> <b>47145</b>
	IN [2]	31,0 x 7 x 104,1	S - Cr -	- 45° - -	22 - III	1397641 1397641-0 13976410 9207874	
	IN [2] EX [2]	32,0 x 6 x 104,3 27,0 x 6 x 103,3	S - Ni - RA/S- Ni -	- 45° - - - 45° - VS -	22 - III 22 - III	9454608 9454609 9454610	
EX [2]	27,0 x 7 x 103,3	A/S - Cr -	- 45° - VS -	22 - III	1366490 1366882 1366882-7 13668827 9207880 9207977 9471463 9471466	<b>47130</b>	
	[50] [50]	Ø 6 mm Ø 7 mm					<b>MK-6H</b> <b>MK-7H</b>
	IN/EX [6]	11,99 x 7 x 45,0	G1			1270391	<b>81-47105</b>
<b>22</b>		<b>81</b>					
<b>B 5204</b>	<b>T8, T9</b>						
		04.2012 →	B (A)	5	1984 cm <sup>3</sup> 4V	132-157 kW (180-214 PS)	9,5 77,00 mm
<b>B 6284</b>	<b>T2</b>						
			B (LA)	6	2783 cm <sup>3</sup> 4V	200 kW (272 PS)	8,7:1 90,00 mm
	IN [2]	31,0 x 6 x 104,3	S - Cr -	- 45° - -	22 - III	9454607	<b>471206</b> <small>NEW</small> <b>471207</b> <small>NEW</small> <b>471209</b> <small>NEW</small>
	IN [2]	32,0 x 6 x 104,3	S - Ni -	- 45° - -	22 - III	9454608	
	EX [2]	27,0 x 6 x 103,3	RA/S- Ni -	- 45° - VS -	22 - III	9454609 9454610	
	[50]	Ø 6 mm					<b>MK-6H</b>
<b>23</b>		<b>81</b>					
<b>D 5252</b>	<b>T</b>						
		01.1996 →	D (A)	5	2460 cm <sup>3</sup> 2V	103 kW (140 PS)	20,5 95,50 mm
	94 429 7..., 94 430 7..						
	IN [2]	36,0 x 8 x 96,9	RA/S- -	- 45° - VS -	22 - III	9186565	<b>39423</b> (1) <b>331141</b> (2) <b>331142</b>
	IN [2]	36,1 x 8 x 96,9	S - -	- 45° - -	22 - III		
	EX [2]	31,6 x 8 x 96,9	RA/S- -	- 45° - -	22 - III	9186566	
	(1)	OES specification					
	(2)	IAM specification					
	[50]	Ø 8 mm				20510747 419643	<b>MK-8H</b>
	IN/EX [4]	12,06/15 x 8 x 36,5	B1			1257613	<b>81-3310</b> <b>81-3312</b> <b>81-3311</b>
	IN/EX [4]	12,13/15 x 8 x 36,5	B1				
	IN/EX [4]	12,20/15 x 8 x 36,5	B1				
	- - G - S -		- SB - -				<b>50 003 115</b>  <b>50 003 415</b>
						35 Nm 60 Nm 2 x 90° 90° warm/chaud/caliente	
	CAM - V - G - S -		- SB - -			ready-to-install	

Fortsetzung nächste Seite / continued on next page / suite page suivante / continuación página próxima / Продолжение на следующей странице

					Reference	Item No.	
<b>24</b>		<b>81</b>					
<b>D 5244 Euro 4</b>	<b>T4, T5, T8</b>	01.2001 →	D (LA) 5	2400 cm <sup>3</sup> 4V	120-136 kW (163-185 PS)	17,3 93,15 mm	
<b>D 5244 Euro 4</b>	<b>T, T2</b>	01.2001 → 04.2010	D (LA) 5	2401 cm <sup>3</sup> 4V	96-120 kW (131-163 PS)	18 93,20 mm	
	IN [2] EX [2]	28,8 x 6 x 98,1 26,2 x 6 x 97,7	S - Ni - A/S - Ni -	- 45° - - 45° - VS -	22 - III 22 - III	8631650 8631651	<b>471204</b> <b>471205</b>
	[50]	∅ 6 mm					<b>MK-6H</b>
	IN/EX [6]	11,50 x 6 x 39,6	G2				<b>81-47121</b>
	[8]	H 12 x 34,5 x 34,5			8670047		<b>50 006 414</b>
<b>25</b>		<b>81</b>					
<b>D 5204</b>	<b>T, T2, T3, T4, T5, T6, T7</b>	10.2007 →	D (A) 5	1984 cm <sup>3</sup> 4V	100-130 kW (136-177 PS)	16,5 77,00 mm	
<b>D 5244 Euro 5</b>	<b>T11, T12, T14, T15, T16, T17, T18, T19, T20, T22, T23</b>	08.2007 →	D (LA) 5	2400 cm <sup>3</sup> 4V	120-169 kW (163-230 PS)	93,15 mm	
<b>D 5244</b>	<b>T21</b>	03.2015 → 07.2018	D (LA) 5	2400 cm <sup>3</sup> 4V	140-162 kW (190-220 PS)	16,5 93,15 mm	
<b>D 5244 Euro 4</b>	<b>T3</b>	10.2003 → 12.2005	D (LA) 5	2401 cm <sup>3</sup> 4V	85 kW (116 PS)	18 93,20 mm	
	IN [2] EX [2]	28,8 x 6 x 98,1 26,2 x 6 x 97,7	S - Ni - A/S - Ni -	- 45° - - 45° - VS -	22 - III 22 - III	8631650 8631651	<b>471204</b> <b>471205</b>
	[50]	∅ 6 mm					<b>MK-6H</b>
<b>26</b>		<b>81</b>					
<b>D 5244 Euro 4</b>	<b>T6, T7, T9</b>	03.2005 →	D (LA) 5	2400 cm <sup>3</sup> 4V	90-120 kW (122-163 PS)	17,3 93,15 mm	
<b>D 5244 Euro 5</b>	<b>T10, T13</b>	03.2006 → 06.2013	D (LA) 5	2400 cm <sup>3</sup> 4V	132-151 kW (180-205 PS)	93,15 mm	
<b>D 5244</b>	<b>T3</b>		D (LA) 5	2401 cm <sup>3</sup> 4V	136 kW (185 PS)	17,3:1 93,20 mm	
	IN [2] EX [2]	28,8 x 6 x 98,1 26,2 x 6 x 97,7	S - Ni - A/S - Ni -	- 45° - - 45° - VS -	22 - III 22 - III	8631650 8631651	<b>471204</b> <b>471205</b>
	[50]	∅ 6 mm					<b>MK-6H</b>
	[8]	H 12 x 34,5 x 34,5			8670047		<b>50 006 414</b>
<b>27</b>		<b>82</b>					
<b>B 4204</b>	<b>T14, T15, T17, T19, T20, T21, T23, T26, T31, T37, T38, T44</b>	01.2014 →	B (A) 4	1969 cm <sup>3</sup> 4V	90-192 kW (122-261 PS)	93,20 mm	
<b>B 4204 Euro 6</b>	<b>T11</b>	09.2013 →	B (A) 4	1969 cm <sup>3</sup> 4V	180-186 kW (245-253 PS)	10 93,20 mm	
	IN [2] EX [2]	31,0 x 6 x 109,2 27,0 x 6 x 110,8	S - Ni - RA/S- Cr -	- 45° - - 45° - VS -	22 - III 22 - III	31375630 31375493 31480436	<b>471200</b> <b>471210</b>
	[50]	∅ 6 mm					<b>MK-6H</b>

V

					Reference	Item No.		
<b>28</b>	<b>82</b>							
<b>D 4204</b>	<b>T11, T12, T14, T23, T6, T7</b>							
	05.2014 →	D (A)	4	1969 cm <sup>3</sup>	4V	120-177 kW (163-241 PS)	93,20 mm	
<b>D 4204</b>	<b>T16, T20, T4, T5, T8, T9</b>							
	09.2013 →	D (LA)	4	1969 cm <sup>3</sup>	4V	88-145 kW (120-197 PS)	93,20 mm	
	IN [2] EX [2]	28,9 x 6 x 100,9 24,3 x 6 x 100,2	S - Ni - A/S - Ni -	- 45° - - 45° -	- VS -	22 - III 22 - III	31375602 31375168	<b>471202</b> <small>NEW</small> <b>471203</b> <small>NEW</small>
	[50]	∅ 6 mm						<b>MK-6H</b>
<b>29</b>	<b>82,7</b>							
<b>B 20</b>	<b>F</b>							
	09.1972 → 07.1996	B (NA)	4	1998 cm <sup>3</sup>	2V	80-88 kW (108-120 PS)	9,5	93,00 mm
	[50]	∅ 8 mm					20510747 419643	<b>MK-8H</b>
	IN [4] EX [4]	13,50 x 8 x 52,0 13,50 x 8 x 52,0	G1 G1				419652 3547603 463771	<b>81-4716</b> <b>81-4719</b>
	EX [4]	13,50 x 8 x 59,0	G1				419653	<b>81-4717</b>
<b>30</b>	<b>82,7</b>							
<b>B 18</b>	<b>U</b>							
	01.1992 → 12.1996	B (NA)	4	1794 cm <sup>3</sup>	2V	66 kW (90 PS)	9,7	83,50 mm
	EX [2]	32,5 x 8 x 111,3	A/S - -	- 45° -	VS -	1 - III	3342399 3342399-7 33423997 3343738 3343738-5 33437385	<b>517981</b>
	[50]	∅ 7 mm					3104400 3104400-1	<b>KK-7H</b>
	[50]	∅ 8 mm					8420816 8420816-4	<b>KK-8H</b>
	IN/EX [4]	13,07 x 8 x 37,7	B1				3343624	<b>81-47103</b>
<b>31</b>	<b>82,7</b>							
<b>B 20</b>	<b>F 208</b>							
		B	4	1998 cm <sup>3</sup>	2V	80 kW (109 PS)	9,5:1	93,00 mm
	IN [2]	40,2 x 8 x 107,0	S - -	- 45° -	-	1 - III	3344841 3344841-6 855926	<b>510201</b>
	EX [2]	32,6 x 8 x 107,0	A/S - -	- 45° -	VS -	1 - III	3344842 3344842-4 855927	<b>510202</b>
	[50]	∅ 8 mm					8420816 8420816-4	<b>KK-8H</b>
	IN/EX [4]	13,07 x 8 x 37,7	B1				3343624	<b>81-47103</b>
<b>32</b>	<b>83</b>							
<b>B 4184 KAT</b>	<b>S9</b>							
	03.1999 → 12.2004	BG (NA)	4	1783 cm <sup>3</sup>	4V	88-90 kW (120-122 PS)	10,3	82,40 mm
Fortsetzung nächste Seite / continued on next page / suite page suivante / continuación página próxima / Продолжение на следующей странице								

					Reference	Item No.	
	IN [2]	31,0 x 7 x 104,1	S - Cr -	- 45° - -	22 - III	1397641 1397641-0 13976410 9207874	<b>47145</b>
	EX [2]	27,0 x 7 x 103,3	A/S - Cr -	- 45° - VS -	22 - III	1366490 1366882 1366882-7 13668827 9207880 9207977 9471463 9471466	<b>47130</b>
	[50]	Ø 7 mm					<b>MK-7H</b>
	IN/EX [6]	11,99 x 7 x 45,0	G1			1270391	<b>81-47105</b>
	[8]	H 32 x 26				1275353 1366842 9207830	<b>50 007 605</b>

<b>33</b>		<b>83</b>								
<b>B 5244</b>	<b>SG, SG2</b>	03.1999 → 04.2010	BG (NA)	5	2435 cm <sup>3</sup>	4V	103 kW	(140 PS)	10,3	90,00 mm

	IN/EX [6]	11,99 x 7 x 45,0	G1				1270391			<b>81-47105</b>
--	-----------	------------------	----	--	--	--	---------	--	--	-----------------

<b>34</b>		<b>83</b>								
<b>B 4184</b>	<b>S</b>	01.1996 → 08.1999	B (NA)	4	1731 cm <sup>3</sup>	4V	85 kW	(115 PS)	10,5	80,00 mm
<b>B 4184</b>	<b>S3</b>	07.1995 → 08.1999	B (NA)	4	1731 cm <sup>3</sup>	4V	85 kW	(116 PS)	10,5	80,00 mm
<b>B 4184</b>	<b>S2</b>	03.1999 → 06.2004	B (NA)	4	1783 cm <sup>3</sup>	4V	85-90 kW	(116-122 PS)	10,5	82,40 mm
<b>B 4204</b>	<b>S, T, T2, T3</b>	07.1995 → 06.2004	B (A)	4	1948 cm <sup>3</sup>	4V	100-184 kW	(136-250 PS)		90,00 mm
<b>B 5244</b>	<b>S</b>	12.1995 → 04.2010	B (NA)	5	2435 cm <sup>3</sup>	4V	125 kW	(170 PS)	9,7	90,00 mm
<b>B 5254</b>	<b>T</b>	05.1996 → 10.2005	B (A)	5	2435 cm <sup>3</sup>	4V	142 kW	(193 PS)	9	90,00 mm
<b>B 5254</b>	<b>S</b>	01.1992 → 10.2005	B (NA)	5	2435 cm <sup>3</sup>	4V	121-125 kW	(165-170 PS)	10,3	90,00 mm
<b>B 6304</b>	<b>S, S3</b>	08.1990 → 07.2006	B (NA)	6	2922 cm <sup>3</sup>	4V	150 kW	(204 PS)		90,00 mm

	IN [2]	31,0 x 7 x 104,1	S - Cr -	- 45° - -	22 - III	1397641 1397641-0 13976410 9207874	<b>47145</b>
	EX [2]	27,0 x 7 x 103,3	A/S - Cr -	- 45° - VS -	22 - III	1366490 1366882 1366882-7 13668827 9207880 9207977 9471463 9471466	<b>47130</b>
	[50]	Ø 7 mm					<b>MK-7H</b>
	IN/EX [6]	11,99 x 7 x 45,0	G1			1270391	<b>81-47105</b>

Fortsetzung nächste Seite / continued on next page / suite page suivante / continuación página próxima / Продолжение на следующей странице

					Reference	Item No.	
[8]	H 32 x 26				1275353 1366842 9207830	<b>50 007 605</b>	
<b>35</b>	<b>83</b>						
<b>B 4204</b>	<b>S2</b> 07.1995 → 06.2004	B (NA)	4	1948 cm <sup>3</sup>	4V 100 kW (136 PS)	10,3 90,00 mm	
<b>B 5244</b>	<b>S2, S4, S5</b> 07.1997 → 12.2012	B (NA)	5	2435 cm <sup>3</sup>	4V 103-125 kW (140-170 PS)	10,3 90,00 mm	
<b>B 5254</b>	<b>FS</b> 12.1995 → 05.2000	B (NA)	5	2435 cm <sup>3</sup>	4V 125 kW (170 PS)	10,3 90,00 mm	
<b>B 6304</b>	<b>F2</b>	B	6	2922 cm <sup>3</sup>	4V 135 kW (184 PS)	10,7:1 90,00 mm	
<b>B 6304</b>	<b>F</b>	B (NA)	6	2922 cm <sup>3</sup>	4V 150-152 kW (204-207 PS)	10,7 90,00 mm	
IN [2]	31,0 x 7 x 104,1	S - Cr -	- 45° -	-	22 - III	1397641 1397641-0 13976410 9207874	<b>47145</b>
EX [2]	27,0 x 7 x 103,3	A/S - Cr -	- 45° - VS -	-	22 - III	1366490 1366882 1366882-7 13668827 9207880 9207977 9471463 9471466	<b>47130</b>
[50]	∅ 7 mm						<b>MK-7H</b>
IN/EX [6]	11,99 x 7 x 45,0	G1				1270391	<b>81-47105</b>
<b>36</b>	<b>83</b>						
<b>B 5244</b>	<b>T</b> 04.1996 → 10.2005	B (A)	5	2435 cm <sup>3</sup>	4V 142 kW (193 PS)	9,1 90,00 mm	
IN/EX [6]	11,99 x 7 x 45,0	G1				1270391	<b>81-47105</b>
[8]	H 32 x 26					1275353 1366842 9207830	<b>50 007 605</b>
<b>37</b>	<b>83</b>						
<b>B 6294</b>	<b>T</b> 06.2001 → 12.2006	B (A)	6	2922 cm <sup>3</sup>	4V 200 kW (272 PS)	8,5 90,00 mm	
<b>B 6294</b>	<b>S, S2</b> 05.1998 → 02.2008	B (NA)	6	2922 cm <sup>3</sup>	4V 144-147 kW (196-200 PS)	90,00 mm	
IN [2]	31,0 x 6 x 104,3	S - Cr -	- 45° -	-	22 - III	9454607	<b>471206</b>
IN [2]	32,0 x 6 x 104,3	S - Ni -	- 45° -	-	22 - III	9454608	<b>471207</b>
EX [2]	27,0 x 6 x 103,3	RA/S- Ni -	- 45° - VS -	-	22 - III	9454609 9454610	<b>471209</b>
[50]	∅ 6 mm						<b>MK-6H</b>
[8]	H 32 x 26					1275353 1366842 9207830	<b>50 007 605</b>
<b>38</b>	<b>83</b>						
<b>B 4204</b>	<b>T5</b> 07.2000 → 06.2004	B (A)	4	1948 cm <sup>3</sup>	4V 147 kW (200 PS)	8,5 90,00 mm	

Fortsetzung nächste Seite / continued on next page / suite page suivante / continuación página próxima / Продолжение на следующей странице



					Reference	Item No.		
	IN [2]	31,0 x 6 x 109,2	S - Ni -	- 45° - -	22 - III	31375630	<b>471200</b> <small>NEW</small> <b>47145</b>	
	IN [2]	31,0 x 7 x 104,1	S - Cr -	- 45° - -	22 - III	1397641 1397641-0 13976410 9207874		
	EX [2]	27,0 x 6 x 110,8	RA/S- Cr -	- 45° - VS -	22 - III	31375493 31480436		<b>471210</b> <small>NEW</small>
	EX [2]	27,0 x 7 x 103,3	A/S - Cr -	- 45° - VS -	22 - III	1366490 1366882 1366882-7 13668827 9207880 9207977 9471463 9471466		<b>47130</b>
	[50] [50]	∅ 6 mm ∅ 7 mm					<b>MK-6H</b> <b>MK-7H</b>	
	IN/EX [6]	11,99 x 7 x 45,0	G1			1270391	<b>81-47105</b>	
<b>39</b>		<b>83</b>						
<b>B 5254</b>	<b>T2</b>	07.2001 → 12.2014	B (A)	5	2521 cm <sup>3</sup> 4V	153-162 kW (209-220 PS)	9 93,20 mm	
	IN [2]	31,0 x 6 x 104,3	S - Cr -	- 45° - -	22 - III	9454607	<b>471206</b> <small>NEW</small>	
	IN [2]	32,0 x 6 x 104,3	S - Ni -	- 45° - -	22 - III	9454608	<b>471207</b> <small>NEW</small>	
	EX [2]	27,0 x 6 x 103,3	RA/S- Ni -	- 45° - VS -	22 - III	9454609 9454610	<b>471209</b> <small>NEW</small>	
	[50]	∅ 6 mm					<b>MK-6H</b>	
	IN/EX [6]	11,99 x 7 x 45,0	G1			1270391	<b>81-47105</b>	
<b>40</b>		<b>83</b>						
<b>B 5254</b>	<b>T4, T7</b>	01.2003 →	B (A)	5	2521 cm <sup>3</sup> 4V	169-224 kW (230-305 PS)	9 93,20 mm	
<b>B 5254</b>	<b>T6</b>	03.2006 → 12.2011	B (LA)	5	2521 cm <sup>3</sup> 4V	147 kW (200 PS)	9 93,20 mm	
	IN [2]	31,0 x 6 x 104,3	S - Cr -	- 45° - -	22 - III	9454607	<b>471206</b> <small>NEW</small> <b>47145</b>	
	IN [2]	31,0 x 7 x 104,1	S - Cr -	- 45° - -	22 - III	1397641 1397641-0 13976410 9207874		
	IN [2]	32,0 x 6 x 104,3	S - Ni -	- 45° - -	22 - III	9454608		<b>471207</b> <small>NEW</small>
	EX [2]	27,0 x 6 x 103,3	RA/S- Ni -	- 45° - VS -	22 - III	9454609 9454610		<b>471209</b> <small>NEW</small>
EX [2]	27,0 x 7 x 103,3	A/S - Cr -	- 45° - VS -	22 - III	1366490 1366882 1366882-7 13668827 9207880 9207977 9471463 9471466	<b>47130</b>		
	[50] [50]	∅ 6 mm ∅ 7 mm					<b>MK-6H</b> <b>MK-7H</b>	
	IN/EX [6]	11,99 x 7 x 45,0	G1			1270391	<b>81-47105</b>	

V

										Reference	Item No.	
<b>41</b>	<b>83</b>											
<b>B 5254</b>	<b>T12, T14</b> 01.2012 →	B (A)	5	2497 cm <sup>3</sup>	4V	183-187 kW	(249-254 PS)	9,5	92,30 mm			
<b>B 5254</b>	<b>T10, T3</b> 12.2003 → 12.2012	B (A)	5	2521 cm <sup>3</sup>	4V	162-170 kW	(220-231 PS)	9	93,20 mm			
<b>B 6294</b>	<b>S3</b>	B	6	2922 cm <sup>3</sup>	4V	147 kW	(200 PS)	10,3:1	90,00 mm			
	IN [2] IN [2] EX [2]	31,0 x 6 x 104,3 32,0 x 6 x 104,3 27,0 x 6 x 103,3	S - Cr - S - Ni - RA/S- Ni -	- 45° - - 45° - - 45° - VS -	- - -	22 - III 22 - III 22 - III	9454607 9454608 9454609 9454610			<b>471206</b> <b>471207</b> <b>471209</b>		
	[50]	∅ 6 mm										<b>MK-6H</b>
<b>42</b>	<b>83</b>											
<b>B 4184</b>	<b>S11</b> 04.2004 → 12.2012	B (NA)	4	1798 cm <sup>3</sup>	4V	92 kW	(125 PS)	10,8:1	83,10 mm			
	IN [2] EX [2]	32,5 x 5,5 x 103,4 28,0 x 5,5 x 104,7	S - Ni - A - Ni -	- 45° - - 45° -	- -	1 - 1 -	8694781 8694780			<b>181110</b> <b>181111</b>		
<b>43</b>	<b>83</b>											
<b>B 4184 KAT</b>	<b>S8</b> 01.2005 → 12.2012	AB (NA)	4	1798 cm <sup>3</sup>	4V	92 kW	(125 PS)	10,3:1	83,10 mm			
	IN/EX [6]	11,99 x 7 x 45,0	G1				1270391			<b>81-47105</b>		
<b>44</b>	<b>84,14</b>											
<b>B 17</b>	<b>A</b> 11.1978 → 07.1988	B	4	1784 cm <sup>3</sup>	2V	66 kW	(90 PS)	80,00 mm				
	IN [2] EX [2]	44,0 x 8 x 110,5 35,0 x 8 x 110,8	S - Cr - A/S - Cr -	- 45° - - 45° - VS -	- -	22 - III 22 - III	463395 463395-4 4633954 463526 463526-4 4635264			<b>4717</b> <b>4718</b>		
	[50]	∅ 8 mm				20510747 419643			<b>MK-8H</b>			
	IN [4] EX [4] EX [4]	13,50 x 8 x 52,0 13,50 x 8 x 52,0 13,50 x 8 x 59,0	G1 G1 G1				419652 3547603 463771 419653			<b>81-4716</b> <b>81-4719</b> <b>81-4717</b>		
<b>45</b>	<b>85</b>											
<b>D 4204</b>	<b>T, T2</b> 12.2002 → 12.2015	D (LA)	4	1998 cm <sup>3</sup>	4V	96-100 kW	(131-136 PS)	19,5	88,00 mm			
99 700 6..	IN [2] EX [2]	30,0 x 6 x 105,0 25,0 x 6 x 105,0	S - Cr - A/S - Cr -	- 45° - - 45° - VS -	- -	22 - III 22 - III	8653745 8653744			<b>181104</b> <b>181105</b>		
	[50]	∅ 6 mm										<b>MK-6H</b>
	IN/EX [4]	10,52 x 6 x 41,5	G1								<b>81-5330</b>	
	[8]	H 12 x 34,5 x 34,5				8670047			<b>50 006 414</b>			

					Reference	Item No.		
<b>46</b>		<b>87,5</b>						
<b>B 4204</b>	<b>S3</b>							
10.2006 → 12.2012 B (NA) 4 1999 cm <sup>3</sup> 4V 107 kW (146 PS) 10,8 83,10 mm								
99 457 6..								
	IN [2]	35,0 x 5,5 x 103,5	S - Ni -	- 45° -	1 -	30777329	<b>181108</b>	
	EX [2]	30,0 x 5,5 x 104,7	A - Ni -	- 45° -	1 -	30777328	<b>181109</b>	
<b>47</b>		<b>87,5</b>						
<b>B 4204</b>	<b>T6</b>							
09.2009 → 12.2012 B (A) 4 1999 cm <sup>3</sup> 4V 149 kW (203 PS) 10 83,10 mm								
<b>B 4204</b>	<b>T7</b>							
01.2010 → 02.2017 B (LA) 4 1999 cm <sup>3</sup> 4V 176-180 kW (239-245 PS) 10 83,10 mm								
40 315 6..								
	IN [2]	31,0 x 6 x 109,2	S - Ni -	- 45° -	22 - III	31375630	<b>471200</b> <small>NEW</small>	
	EX [2]	27,0 x 6 x 110,8	RA/S- Cr -	- 45° - VS -	22 - III	31375493 31480436	<b>471210</b> <small>NEW</small>	
	[50]	Ø 6 mm					<b>MK-6H</b>	
<b>48</b>		<b>87,5</b>						
<b>B 4204</b>	<b>S4</b>							
01.2008 → 12.2012 AB (NA) 4 1999 cm <sup>3</sup> 4V 107 kW (146 PS) 10,8 83,10 mm								
	IN/EX [6]	11,99 x 7 x 45,0	G1				1270391	<b>81-47105</b>
<b>49</b>		<b>88</b>						
<b>B 27</b>	<b>E, F</b>							
01.1975 → 07.1982 B (NA) 6 2664 cm <sup>3</sup> 2V 103-109 kW (140-148 PS) 73,00 mm								
	IN [2]	43,9 x 8 x 112,0	S - -	- 30° -	1 - III	245390 245390-0 2453900	<b>536226</b>	
	EX [2]	37,0 x 8 x 111,3	A/S - Cr -	- 45° - VS -	1 - III	245802 245802-4 2458024	<b>538930</b>	
	[50]	Ø 8 mm				8420816 8420816-4	<b>KK-8H</b>	
<b>50</b>		<b>88,9</b>						
<b>B 20</b>	<b>A, B, E</b>							
01.1961 → B (NA) 4 1986 cm <sup>3</sup> 2V 60-103 kW (82-140 PS) 80,00 mm								
<b>B 30</b>	<b>A, E, F</b>							
1968 → 11.1991 B (NA) 6 2978 cm <sup>3</sup> 2V 92-118 kW (125-160 PS) 80,00 mm								
	IN [4]	13,50 x 8 x 52,0	G1				419652	<b>81-4716</b>
	EX [4]	13,50 x 8 x 52,0	G1				3547603 463771	<b>81-4719</b>
	EX [4]	13,50 x 8 x 59,0	G1				419653	<b>81-4717</b>

V

					Reference	Item No.	
<b>51</b>	<b>88,9</b>						
<b>B 19</b>	<b>K</b>						
	09.1978 → 12.1984	B (NA)	4	1986 cm <sup>3</sup>	2V 71-74 kW (97-101 PS)	9,2 80,00 mm	
<b>B 19</b>	<b>A, E</b>						
	09.1974 → 12.1993	B (NA)	4	1986 cm <sup>3</sup>	2V 60-86 kW (82-117 PS)	80,00 mm	
<b>B 19</b>	<b>ET</b>						
	10.1982 → 05.1993	B (A)	4	1986 cm <sup>3</sup>	2V 100-110 kW (136-150 PS)	9,3:1 80,00 mm	
<b>B 200</b>	<b>F</b>						
	08.1986 → 07.1994	B (NA)	4	1986 cm <sup>3</sup>	2V 80-82 kW (109-112 PS)	10:1 80,00 mm	
<b>B 200</b>	<b>ET</b>						
	01.1985 → 08.1990	B (A)	4	1986 cm <sup>3</sup>	2V 115-121 kW (156-165 PS)	8,5 80,00 mm	
<b>B 200</b>	<b>E, EA, K, KE</b>	B (NA)	4	1986 cm <sup>3</sup>	2V 70-89 kW (95-121 PS)	80,00 mm	
<b>B 200</b>	<b>FT</b>	B (A)	4	1986 cm <sup>3</sup>	2V 105-114 kW (143-155 PS)	8,5 80,00 mm	
	IN [2]	44,0 x 8 x 110,5	S - Cr -	- 45° -	- 22 - III	463395 463395-4 4633954	<b>4717</b>
	EX [2]	35,0 x 8 x 110,8	A/S - Cr -	- 45° - VS -	22 - III	463526 463526-4 4635264	<b>4718</b>
	[50]	∅ 8 mm				20510747 419643	<b>MK-8H</b>
	IN [4]	13,50 x 8 x 52,0	G1			419652	<b>81-4716</b>
	EX [4]	13,50 x 8 x 52,0	G1			3547603 463771	<b>81-4719</b>
	EX [4]	13,50 x 8 x 59,0	G1			419653	<b>81-4717</b>
<b>52</b>	<b>88,9</b>						
<b>B 200</b>	<b>G</b>						
	08.1985 → 12.1995	B (NA)	4	1986 cm <sup>3</sup>	2V 80-89 kW (109-121 PS)	10:1 80,00 mm	
	IN [4]	13,50 x 8 x 52,0	G1			419652	<b>81-4716</b>
	EX [4]	13,50 x 8 x 52,0	G1			3547603 463771	<b>81-4719</b>
<b>53</b>	<b>88,9</b>						
<b>B 204</b>	<b>E</b>						
	09.1987 → 08.1993	B (NA)	4	1986 cm <sup>3</sup>	4V 100-103 kW (136-140 PS)	10,1:1 80,00 mm	
	EX [2]	29,0 x 7 x 108,3	A/S - Cr -	- 45° - VS -	22 - III		<b>105-35501</b>
	[50]	∅ 7 mm					<b>MK-7H</b>
	IN/EX [4]	12,00 x 7 x 55,0	G1			1378960	<b>81-47113</b>
	IN/EX [4]	12,05 x 7 x 49,5	G1				<b>81-5200</b>
<b>54</b>	<b>88,9</b>						
<b>B 204</b>	<b>FT</b>						
	08.1990 → 05.1997	B (LA)	4	1986 cm <sup>3</sup>	4V 102-140 kW (139-190 PS)	8,2 80,00 mm	
	[50]	∅ 7 mm					<b>MK-7H</b>
	IN/EX [4]	11,04 x 6 x 39,0	B1				<b>81-33121</b> <small>NEW</small>
	IN/EX [4]	11,05 x 6 x 36,0	B1				<b>81-33111</b>
	IN/EX [4]	11,15 x 6 x 36,0	B1				<b>81-33118</b> <small>NEW</small>
	IN/EX [4]	12,00 x 7 x 55,0	G1			1378960	<b>81-47113</b>
	EX [4]	11,04 x 6 x 39,0	G2				<b>81-33122</b> <small>NEW</small>

					Reference	Item No.	
<b>55</b>		<b>89</b>					
<b>MD 11</b>		D (LA) 1		4V		90,00 mm	
	IN [2]	40,0 x 8 x 192,0	RA/S- Cr -	- 30° - VS -	22 - III	20540012 20540013 20540017 20737856 21427620	<b>48313</b>
	EX [2]	38,0 x 8 x 192,7	RA/S- Cr -	- 30° - VS -	22 - III	20464020 20564019 20564020 21430918 22686466 3842972	<b>48314</b>
	[50]	Ø 8 mm				20510747 419643	<b>MK-8H</b>
	IN/EX [6]	15,00 x 8.01 x 83,4	G2			1546437 20817645 20817648 20904074 20905400 20919484 3165303 3183283	<b>81-47119</b>
	IN/EX [6]	15,00 x 8.02 x 83,2	G2			1546437 20817645 20817648 20904074 20905400 20919484 3165303 3183283	<b>81-47114</b>
	IN [1] EX [1]	42,00 x 33 x 7,3 40,00 x 31.2 x 6,4	G3 30° G3 30°			20509465 20732758	<b>92-47030</b> <b>92-47031</b>
<b>56</b>		<b>91</b>					
<b>B 28</b>		<b>A, F</b>					
		09.1979 → 12.1987	B (NA) 6	2849 cm <sup>3</sup>	2V	95-114 kW (129-155 PS) 8,8	73,00 mm
<b>B 28</b>		<b>E</b>					
		10.1980 → 07.1988	B (NA) 6	2849 cm <sup>3</sup>	2V	114-125 kW (155-170 PS) 9,5-10	73,00 mm
	IN [2]	43,9 x 8 x 112,0	S - -	- 30° -	1 - III	245390 245390-0 2453900	<b>536226</b>
	EX [2]	37,0 x 8 x 111,3	A/S - Cr -	- 45° - VS -	1 - III	245802 245802-4 2458024	<b>538930</b>
	[50]	Ø 8 mm				8420816 8420816-4	<b>KK-8H</b>
<b>57</b>		<b>92</b>					
<b>B 21</b>		<b>A, E, F</b>					
		01.1975 → 12.1984	B (NA) 4	2127 cm <sup>3</sup>	2V	71-91 kW (97-124 PS) 9,3	80,00 mm
<b>B 21</b>		<b>ET, FT</b>					
		08.1980 → 12.1985	B (A) 4	2127 cm <sup>3</sup>	2V	114-121 kW (155-165 PS) 7,5	80,00 mm
92 776 6..							
Fortsetzung nächste Seite / continued on next page / suite page suivante / continuación página próxima / Продолжение на следующей странице							

V

					Reference	Item No.
IN [2]	44,0 x 8 x 110,5	S - Cr -	- 45° - -	22 - III	463395 463395-4 4633954	<b>4717</b>
EX [2]	35,0 x 8 x 110,8	A/S - Cr -	- 45° - VS -	22 - III	463526 463526-4 4635264	<b>4718</b>
[50]	Ø 8 mm				20510747 419643	<b>MK-8H</b>
IN [4]	13,50 x 8 x 52,0	G1			419652	<b>81-4716</b>
EX [4]	13,50 x 8 x 52,0	G1			3547603 463771	<b>81-4719</b>
EX [4]	13,50 x 8 x 59,0	G1			419653	<b>81-4717</b>

## 58 92

<b>AD 31</b>	<b>A, B, D-A, L-A, P-A</b> 1986 →	D (LA)	4	2390 cm <sup>3</sup>	2V	96-110 kW	(130-150 PS)	17,5:1	90,00 mm
<b>AD 41</b>	<b>B, D, L-A, P-A</b> 1989 →	D (LA)	6	3590 cm <sup>3</sup>	2V	113-147 kW	(153-200 PS)	17,5:1	90,00 mm
<b>AQAD 30</b>	<b>A</b> 1983 → 1986	D	4	2390 cm <sup>3</sup>	2V	81 kW	(110 PS)	17,5:1	90,00 mm
<b>AQAD 31</b>	<b>A</b> 1986 → 1989	D	4	2390 cm <sup>3</sup>	2V	96 kW	(130 PS)	16:1	90,00 mm
<b>AQAD 40</b>	<b>A, B</b> 1980 → 06.1986	D (LA)	6		2V	81-121 kW	(110-165 PS)	21:1	90,00 mm
<b>D 41</b>	<b>B, D, L-A</b> 1989 → 1998	D (A)	6	3590 cm <sup>3</sup>	2V	110 kW	(150 PS)	17,5:1	90,00 mm
<b>KAD 42</b>	<b>A, B, P-A</b> 1991 → 2001	D (LA)	6	3590 cm <sup>3</sup>	2V	169 kW	(230 PS)	17,8:1	90,00 mm
<b>KAD 43</b>	<b>P-A</b> 1997 → 2005	D (LA)	6	3590 cm <sup>3</sup>	2V	169 kW	(230 PS)	17,5:1	90,00 mm
<b>KAMD 300-A</b>									
	2001 → 2004	D (LA)	6	3590 cm <sup>3</sup>	4V	210 kW	(285 PS)	16,9:1	90,00 mm
<b>KAMD 42</b>	<b>A, B, P-A</b> 1991 → 1997	D (LA)	6	3590 cm <sup>3</sup>	2V	169 kW	(230 PS)		90,00 mm
<b>KAMD 44</b>	<b>P-C</b> 2000 → 2004	D (LA)	6	3590 cm <sup>3</sup>	4V	191 kW	(260 PS)	16,9:1	90,00 mm
<b>MD 40</b>	<b>A</b> 1976 → 1985	D	6	3598 cm <sup>3</sup>	2V	53-63 kW	(72-85 PS)	21:1	90,00 mm
<b>TAMD 31</b>	<b>A, B, D, L-A, M-A, P-A, S-A</b> 1986 → 2004	D (LA)	4	2394 cm <sup>3</sup>	2V	74-110 kW	(100-150 PS)		90,00 mm
<b>TAMD 40</b>	<b>A</b> 06.1979 → 06.1986	D (LA)	6	3598 cm <sup>3</sup>	2V	81-109 kW	(110-148 PS)	21:1	90,00 mm
<b>TAMD 41</b>	<b>A, B, D, H-A, M-A, P-A</b> 1986 → 2005	D (LA)	6	3598 cm <sup>3</sup>	2V	107-147 kW	(145-200 PS)		90,00 mm
<b>TAMD 42</b>	<b>B</b> 1993 → 1996	D (LA)	6	3598 cm <sup>3</sup>	2V	169 kW	(230 PS)	17,8:1	90,00 mm
<b>TMD 30</b>	<b>A</b> 01.1983 → 07.1986	D (A)	4	3598 cm <sup>3</sup>	2V	66 kW	(90 PS)	21:1	90,00 mm
<b>TMD 31</b>	<b>B, D, L-A</b> 1989 → 1997	D (A)	6	3598 cm <sup>3</sup>	2V	74 kW	(100 PS)	16:1	90,00 mm
<b>TMD 40</b>	<b>A, B</b> 1976 → 06.1986	D (A)	6	3598 cm <sup>3</sup>	2V	67-100 kW	(91-136 PS)	21:1	90,00 mm
<b>TMD 41</b>	<b>A, B, D, L-A</b> 1986 → 1997	D (A)	6	3598 cm <sup>3</sup>	2V	110 kW	(150 PS)		90,00 mm

IN [2]	43,10 x 32 x 7,2	G1 30°				20459329 20482579 21484829	<b>92-47019</b>
IN [1]	43,05 x 32 x 7,2	G1 30°					<b>92-47032</b>
EX [2]	43,08 x 32,9 x 8,0	G1 45°				20412798 21484834 3169366	<b>92-47020</b>
EX [1]	43,10 x 32,9 x 8,0	G1 45°					<b>92-47033</b>



					Reference	Item No.		
<b>59</b>		<b>92</b>						
<b>KAMD 43</b>	<b>P-A</b>	1997 → 2005	D (LA)	6	3590 cm <sup>3</sup> 2V	169 kW (230 PS) 17,5:1	90,00 mm	
<b>TAMD 42</b>	<b>W-JA</b>	1995 → 2003	D (LA)	6	3598 cm <sup>3</sup> 2V	169 kW (230 PS) 17,5:1	90,00 mm	
	IN [4] EX [4]	13,50 x 8 x 52,0 13,50 x 8 x 52,0	G1			419652 3547603 463771	<b>81-4716</b> <b>81-4719</b>	
	EX [4]	13,50 x 8 x 59,0	G1			419653	<b>81-4717</b>	
	IN [2]	43,10 x 32 x 7,2	G1 30°			20459329 20482579 21484829	<b>92-47019</b>	
	IN [1] EX [2]	43,05 x 32 x 7,2 43,08 x 32.9 x 8,0	G1 30° G1 45°			20412798 21484834 3169366	<b>92-47032</b> <b>92-47020</b>	
	EX [1]	43,10 x 32.9 x 8,0	G1 45°				<b>92-47033</b>	
<b>60</b>		<b>95</b>						
<b>D 50</b>	<b>A, B</b>	10.1965 → 10.1978	D (NA)	6	5100 cm <sup>3</sup> 2V	79-86 kW (107-117 PS) 17:1	120,00 mm	
	[12]	M 31 x 68				4210670	<b>20 1004 70000</b>	
<b>61</b>		<b>95,25</b>						
<b>TD 50</b>	<b>A, B</b>	01.1965 → 10.1978	D (A)	6	5130 cm <sup>3</sup> 2V	108-121 kW (147-165 PS) 17:1	120,00 mm	
	[12]	M 31 x 68				4210670	<b>20 1004 70000</b>	
<b>62</b>		<b>96</b>						
<b>B 23</b>	<b>ET, FT</b>	08.1982 →	B (A)	4	2316 cm <sup>3</sup> 2V	97-127 kW (132-173 PS)	80,00 mm	
<b>B 23</b>	<b>A, E, F</b>	01.1979 → 08.1987	B (NA)	4	2316 cm <sup>3</sup> 2V	78-103 kW (106-140 PS)	80,00 mm	
<b>B 230</b>	<b>F, FB, FD</b>	09.1981 → 10.1998	B (NA)	4	2316 cm <sup>3</sup> 2V	81-118 kW (110-160 PS)	80,00 mm	
<b>B 230</b>	<b>FK, FT, FT+, FT4</b>	09.1983 →	B (A)	4	2316 cm <sup>3</sup> 2V	99-151 kW (135-205 PS)	80,00 mm	
<b>B 230</b>	<b>G, GK</b>	08.1990 →	B (NA)	4	2316 cm <sup>3</sup> 2V	90-113 kW (122-154 PS)	80,00 mm	
<b>B 230</b>	<b>ET, GT</b>	08.1984 → 08.1991	B (LA)	4	2316 cm <sup>3</sup> 2V	121-134 kW (165-182 PS) 9	80,00 mm	
	IN [2] EX [2]	44,0 x 8 x 110,5 35,0 x 8 x 110,8	S - Cr - A/S - Cr -		- 45° - - 45° - VS -	22 - III	463395 463395-4 4633954 463526 463526-4 4635264	<b>4717</b> <b>4718</b>
	[50]	∅ 8 mm					20510747 419643	<b>MK-8H</b>
	IN [4] EX [4]	13,50 x 8 x 52,0 13,50 x 8 x 52,0	G1 G1			419652 3547603 463771	<b>81-4716</b> <b>81-4719</b>	
	EX [4]	13,50 x 8 x 59,0	G1			419653	<b>81-4717</b>	

V

					Reference	Item No.	
<b>63</b>	<b>96</b>						
<b>B 230</b>	<b>A, E, K</b>	B (NA)	4	2316 cm <sup>3</sup> 2V	80-98 kW (109-133 PS)	80,00 mm	
93 114 7..							
	[50]	Ø 8 mm			20510747 419643	<b>MK-8H</b>	
	IN [4] EX [4]	13,50 x 8 x 52,0 13,50 x 8 x 52,0	G1 G1		419652 3547603 463771	<b>81-4716</b> <b>81-4719</b>	
	EX [4]	13,50 x 8 x 59,0	G1		419653	<b>81-4717</b>	
<b>64</b>	<b>96</b>						
<b>B 234</b>	<b>F</b>	01.1988 → 08.1992	B (NA)	4	2316 cm <sup>3</sup> 4V	111-117 kW (151-159 PS) 10	80,00 mm
93 114 7..							
	IN [2] EX [2]	34,5 x 7 x 122,5 31,5 x 7 x 122,3	A/S - Cr - A/S - Cr -	- 45° - - 45° - VS -	22 - III 22 - III	1317793 1317793-6 13177936 1317792 1317792-8 13177928	<b>4729</b> <b>4730</b>
	[50]	Ø 7 mm				<b>MK-7H</b>	
	IN/EX [4]	12,00 x 7 x 55,0	G1		1378960	<b>81-47113</b>	
<b>65</b>	<b>98</b>						
<b>TAD660VE Euro 3</b>	01.2006 →	D (LA)	6	5702 cm <sup>3</sup> 2V	147 kW (200 PS) 18,4:1	126,00 mm	
40 440 6..							
	IN [2] EX [2]	44,5 x 8 x 121,2 38,8 x 8 x 121,2	S - Cr - RA/S- Cr -	- 30° - VS - - 45° -	22 - III 22 - III	20798699 20798533	<b>22307</b> <b>22308</b>
	[50]	Ø 8 mm			20510747 419643	<b>MK-8H</b>	
	IN/EX [1]	15,03 x 8 x 54,2	G2			<b>81-22114</b> <small>NEW</small>	
	IN [2] EX [2]	46,08 x 35,95 x 6,8 39,98 x 30,1 x 7,4	G1 30° G1 45°		20849976 20849979	<b>92-22013</b> <b>92-22014</b>	
<b>66</b>	<b>98,43</b>						
<b>D 60</b>	<b>A</b>	01.1977 → 02.1980	D (NA)	6	5480 cm <sup>3</sup> 2V	88-92 kW (120-125 PS) 17:1	120,00 mm
<b>D 60</b>		03.1975 → 03.1978	D	6	5480 cm <sup>3</sup> 2V	84-88 kW (115-120 PS) 17:1	120,00 mm
<b>TD 60</b>	<b>A, B, BG, C, D, DG</b>	1974 → 12.1987	D (A)	6	5480 cm <sup>3</sup> 2V	70-132 kW (95-180 PS)	120,00 mm
<b>TD 61</b>	<b>A, ACE, AG, AGP, AP, APB, AW, B, F, FB, G, R</b>	1985 →	D (LA)	6	5480 cm <sup>3</sup> 2V	103-153 kW (140-207 PS)	120,00 mm
<b>TD 61</b>	<b>GA, GB, GC, GE, GS</b>	09.1985 → 08.2000	D (A)	6	5480 cm <sup>3</sup> 2V	112-132 kW (152-180 PS) 16:1	120,00 mm
<b>TD 610</b>	<b>G</b>	1985 →	D (LA)	6	5480 cm <sup>3</sup> 2V	103-150 kW (140-204 PS) 15:1	120,00 mm
93 474 7..., 99 408 6..							
Fortsetzung nächste Seite / continued on next page / suite page suivante / continuación página próxima / Продолжение на следующей странице							

					Reference	Item No.
	IN [2] 41,0 x 8 x 145,3	S - Cr -	- 30° - -	15 - III	420553 420553-0 4205530 465548	48114
	EX [2] 37,0 x 8 x 145,3	A/S - Cr -	- 45° - VS -	17 - III	465549 465549-4 4655494	48115
	[50] Ø 8 mm				465284	RK-8
	[50] Ø 8 mm				1677875	RK-8H
	IN/EX [6] 15,99 x 8 x 65,5	G1			465157 477792 477877	81-47106
	[12] M 31 x 68				4210670	20 1004 70000

## 67 98,43

<b>4.236</b>	09.1975 → 01.1986	D (NA)	4	3866 cm <sup>3</sup>	2V	55-65 kW	(75-88 PS)	16:1	127,00 mm
<b>D 39</b>	<b>C</b>								
	09.1975 → 01.1986	D (NA)	4	3866 cm <sup>3</sup>	2V	59 kW	(80 PS)	16:1	127,00 mm

91 118 6..

	IN [2] 44,2 x 9,5 x 122,8	S - -	- 45° - -	1 - III		105-03365
	IN [2] 44,2 x 9,5 x 122,8	S - -	- 45° - -	1 - III		105-35472
	M + 1					
	EX [2] 36,5 x 9,5 x 123,2	A/S - -	- 45° - -	1 - III		105-03366
	EX [2] 36,6 x 9,5 x 123,3	A/S - -	- 45° - -	1 - III		105-35473
	M + 1					
	IN [6] 15,90 x 9.515 x 57,9	G2				81-85003
	EX [6] 15,90 x 9.53 x 61,1	G2				81-85004

## 68 98,43

<b>TAMD 60</b>	<b>C</b>								
	1978 → 1985	D (A)	6	5480 cm <sup>3</sup>	2V	108-184 kW	(147-250 PS)	16:1	120,00 mm
<b>TAMD 61</b>	<b>A</b>								
	03.1986 → 1995	D (LA)	6	5480 cm <sup>3</sup>	2V	225 kW	(306 PS)	15:1	120,00 mm
<b>TID 61</b>	<b>A, ACE</b>								
	1985 →	D (LA)	6	5480 cm <sup>3</sup>	2V	103-150 kW	(140-204 PS)	15:1	120,00 mm
<b>TWD 610</b>	<b>G</b>								
	1985 →	D (LA)	6	5480 cm <sup>3</sup>	2V	103-150 kW	(140-204 PS)	15:1	120,00 mm

93 474 7..., 99 408 6..

	IN/EX [6] 15,99 x 8 x 65,5	G1			465157 477792 477877	81-47106
	[12] M 31 x 68				4210670	20 1004 70000

## 69 98,43

<b>TD 63 Euro 1</b>	<b>E, ES</b>								
	09.1985 → 08.2000	D (LA)	6	5480 cm <sup>3</sup>	2V	132-154 kW	(180-210 PS)	18,3:1	120,00 mm

99 991 7..

	IN [2] 41,0 x 8 x 145,3	S - Cr -	- 30° - -	15 - III	420553 420553-0 4205530 465548	48114
	EX [2] 37,0 x 8 x 145,3	A/S - Cr -	- 45° - VS -	17 - III	465549 465549-4 4655494	48115
	[50] Ø 8 mm				465284	RK-8
	[50] Ø 8 mm				1677875	RK-8H

Fortsetzung nächste Seite / continued on next page / suite page suivante / continuación página próxima / Продолжение на следующей странице

					Reference	Item No.
	IN/EX [6] 15,99 x 8 x 65,5	G1			465157 477792 477877	<b>81-47106</b>
<b>70</b>	<b>101</b>					
<b>TAD650VE Euro 3</b> 2006 → D (LA) 6 6057 cm <sup>3</sup> 2V 147 kW (200 PS) 18,4:1 126,00 mm 40 441 6..						
	IN [2] 44,5 x 8 x 121,2 EX [2] 38,8 x 8 x 121,2	S - Cr - RA/S- Cr -	- 30° - VS - - 45° - -	22 - III 22 - III	20798699 20798533	<b>22307</b> <b>22308</b>
	[50] Ø 8 mm				20510747 419643	<b>MK-8H</b>
	IN/EX [1] 15,03 x 8 x 54,2	G2				<b>81-22114</b> <small>NEW</small>
	IN [2] 46,08 x 35.95 x 6,8 EX [2] 39,98 x 30.1 x 7,4	G1 30° G1 45°			20849976 20849979	<b>92-22013</b> <b>92-22014</b>
<b>71</b>	<b>104,77</b>					
<b>TD 70</b> ES, FS, G 1974 → D (A) 6 6700 cm <sup>3</sup> 2V 147-180 kW (200-245 PS) 14,5:1 130,00 mm						
<b>TD 71</b> FD, FS, G 1985 → D (LA) 6 2V 178-184 kW (242-250 PS) 15,5:1 130,00 mm 90 741 6.., 92 827 6.., 93 166 6..						
	IN [1] 43,0 x 11 x 148,5 EX [1] 37,0 x 11 x 148,6	S - Cr - A/S - Cr -	- 30° - - - 45° - VS -	9 - III 9 - III	466379 466379-5 4663795 421680 465381 465381-1 471195 471195-8 842080 842080-4	<b>105-35099</b> <b>48302</b>
	[50] Ø 11 mm				468305	<b>RK-11H</b>
	IN/EX [6] 18,00 x 11 x 66,0	G1			466386	<b>81-47112</b>
	IN [2] 46,30 x 37.5 x 6,4 IN [1] 46,10 x 37.5 x 6,2 EX [2] 44,28 x 34.05 x 9,2 EX [1] 44,08 x 34.05 x 9,0	G1 30° G1 30° G1 45° G1 45°			421316 421011 466307 466266	<b>92-47002</b> <b>92-47001</b> <b>92-47004</b> <b>92-47003</b>
	[12] M 31 x 68				4210670	<b>20 1004 70000</b>

					Reference	Item No.	
<b>72</b>		<b>104,775</b>					
<b>D 70</b>	<b>A, B</b>						
	01.1965 → 10.1978	D (NA)	6	6700 cm <sup>3</sup>	2V 106-110 kW (144-150 PS)	17:1 130,00 mm	
<b>D 70</b>	<b>B/BB, CHC, CRC</b>						
	1978 → 1985	D	6	6730 cm <sup>3</sup>	2V 102-110 kW (139-150 PS)	17:1 130,00 mm	
<b>MD 70</b>	<b>B, C</b>						
	12.1970 → 12.1985	D	6	6730 cm <sup>3</sup>	2V 73-107 kW (99-145 PS)	17:1 130,00 mm	
<b>TD 70</b>	<b>A, B, C, E, F, FC, H, HA</b>						
	01.1963 → 01.1996	D (A)	6		2V 136-180 kW (185-245 PS)	130,00 mm	
<b>TD 70</b>	<b>GG</b>						
	03.1983 → 06.1986	D (LA)	6	6730 cm <sup>3</sup>	2V 100-140 kW (136-190 PS)	14,5:1 130,00 mm	
<b>TD 71</b>	<b>A, ACE, AG, AGP, AP, APB, AW, FQ, FQK, FSO, FSQ, K</b>						
	1985 →	D (LA)	6		2V 169-184 kW (220-250 PS)	15,5:1 130,00 mm	
<b>TD 71</b>	<b>E, F, FA, FC, GE</b>						
	09.1985 →	D (A)	6		2V 169-180 kW (220-245 PS)	15,5:1 130,00 mm	
<b>TMD 70</b>	<b>B, C</b>						
	06.1970 → 1985	D (A)	6	6730 cm <sup>3</sup>	2V 110-152 kW (150-207 PS)	16:1 130,00 mm	
90 741 6.., 91 353 6.., 91 354 6.., 92 827 6.., 93 166 6..							
	IN [1]	43,0 x 11 x 148,5	S - Cr -	- 30° - -	9 - III	466379 466379-5 4663795	<b>105-35099</b>
	EX [1]	37,0 x 11 x 148,6	A/S - Cr -	- 45° - VS -	9 - III	421680 465381 465381-1 471195 471195-8 842080 842080-4	<b>48302</b>
	[50]	Ø 11 mm				468305	<b>RK-11H</b>
	IN/EX [6]	18,00 x 11 x 66,0	G1			466386	<b>81-47112</b>
	IN [2]	46,30 x 37.5 x 6,4	G1 30°			421316	<b>92-47002</b>
	IN [1]	46,10 x 37.5 x 6,2	G1 30°			421011	<b>92-47001</b>
	EX [2]	44,28 x 34.05 x 9,2	G1 45°			466307	<b>92-47004</b>
	EX [1]	44,08 x 34.05 x 9,0	G1 45°			466266	<b>92-47003</b>
	[12]	M 31 x 68				4210670	<b>20 1004 70000</b>
<b>73</b>		<b>104,775</b>					
<b>TAMD 70</b>	<b>A, B, C, D, E</b>						
	03.1971 →	D (LA)	6	6730 cm <sup>3</sup>	2V 114-221 kW (155-300 PS)	130,00 mm	
<b>TAMD 71</b>	<b>A, B, D</b>						
	1985 →	D (LA)	6	6730 cm <sup>3</sup>	2V 160-263 kW (218-357 PS)	14:1 130,00 mm	
<b>TID 70</b>	<b>GG</b>						
	01.1986 → 09.1991	D (A)	6	6730 cm <sup>3</sup>	2V 116-154 kW (158-209 PS)	14,5:1 130,00 mm	
92 827 6..							
	IN/EX [6]	18,00 x 11 x 66,0	G1			466386	<b>81-47112</b>
	IN [2]	46,30 x 37.5 x 6,4	G1 30°			421316	<b>92-47002</b>
	IN [1]	46,10 x 37.5 x 6,2	G1 30°			421011	<b>92-47001</b>
	EX [2]	44,28 x 34.05 x 9,2	G1 45°			466307	<b>92-47004</b>
	EX [1]	44,08 x 34.05 x 9,0	G1 45°			466266	<b>92-47003</b>
	[12]	M 31 x 68				4210670	<b>20 1004 70000</b>

V

					Reference	Item No.			
<b>74</b>		<b>104,775</b>							
<b>D7A230 Euro 2</b>	12.1993 →	D (LA)	6	6700 cm <sup>3</sup>	2V	169 kW (230 PS)	18:1	130,00 mm	
<b>D7A260 Euro 2</b>	12.1993 →	D (LA)	6	6700 cm <sup>3</sup>	2V	191 kW (260 PS)	18:1	130,00 mm	
<b>D7A285 Euro 2</b>	10.1993 →	D (LA)	6	6700 cm <sup>3</sup>	2V	210 kW (286 PS)	18:1	130,00 mm	
<b>D7B230 Euro 2</b>	09.1985 →	D (LA)	6	6700 cm <sup>3</sup>	2V	169 kW (230 PS)	18:1	130,00 mm	
<b>D7B260 Euro 2</b>	11.1991 →	D (LA)	6	6700 cm <sup>3</sup>	2V	191 kW (260 PS)	18:1	130,00 mm	
99 749 6..									
	IN [2] EX [2]	43,0 x 8 x 149,7 39,0 x 8 x 149,8	S - Cr - RA/S- Cr -	- 30° - - 45° -	- -	9 - III 9 - III	3978768	<b>48322</b> <b>48326</b>	(1)
	(1)	IAM specification							
	[50]	∅ 8 mm					1677875	<b>RK-8H</b>	
	IN/EX [6]	15,99 x 8 x 65,5	G1				465157 477792 477877	<b>81-47106</b>	
<b>75</b>		<b>104,775</b>							
<b>TD 73 Euro 1</b>	<b>E, EA, EB, ES</b>	09.1985 →	D (LA)	6	2V	160-191 kW (215-260 PS)		130,00 mm	
99 748 6..									
	IN [2] EX [2] EX [2]	43,0 x 8 x 149,7 39,0 x 8 x 149,7 39,0 x 8 x 149,8	S - Cr - I/S - Cr - A/S - Cr -	- 30° - - 45° - - 45° -	- -	17 - III 17 - III 17 - III	477447 477443	<b>48207</b> <b>48208</b> <b>48325</b>	(1) (2)
	(1)	OES specification							
	(2)	IAM specification							
	[50]	∅ 8 mm					1677875	<b>RK-8H</b>	
	IN/EX [6]	15,99 x 8 x 65,5	G1				465157 477792 477877	<b>81-47106</b>	
<b>76</b>		<b>104,775</b>							
<b>TAMD 72</b>	<b>A, P-A, WJ-A</b>	07.1991 → 1997	D (LA)	6	6730 cm <sup>3</sup>	2V	316-331 kW (430-450 PS)	15,6:1	130,00 mm
<b>TAMD 73</b>	<b>P-A, WJ-A</b>	1997 → 1999	D (LA)	6	6730 cm <sup>3</sup>	2V	316-331 kW (430-450 PS)	15,6:1	130,00 mm
	IN/EX [6]	18,00 x 11 x 66,0	G1				466386	<b>81-47112</b>	
	IN [2] IN [1] EX [2] EX [1]	46,30 x 37,5 x 6,4 46,10 x 37,5 x 6,2 44,28 x 34,05 x 9,2 44,08 x 34,05 x 9,0	G1 30° G1 30° G1 45° G1 45°				421316 421011 466307 466266	<b>92-47002</b> <b>92-47001</b> <b>92-47004</b> <b>92-47003</b>	
<b>77</b>		<b>104,775</b>							
<b>TWD 731</b>	<b>ME</b>		D (LA)	6	6721 cm <sup>3</sup>	2V	175 kW (238 PS)	130,00 mm	
<b>TWD 731 Euro 1</b>	<b>VE</b>		D (LA)	6	6721 cm <sup>3</sup>	2V	175 kW (238 PS)	130,00 mm	
99 748 6..									
	IN/EX [6]	15,99 x 8 x 65,5	G1				465157 477792 477877	<b>81-47106</b>	
	IN [2] EX [2]	46,05 x 37,5 x 8,1 42,05 x 32,7 x 8,6	G1 45° G1 45°				477657 477659	<b>92-47021</b> <b>92-47022</b>	



					Reference	Item No.		
<b>78</b>		<b>105</b>	<b>TWD 710</b>					
	<b>G, V</b>							
	09.1994 →	D (LA)	6	6730 cm <sup>3</sup>	2V	145-168 kW (197-228 PS)	14,5:1 130,00 mm	
	IN/EX [6]	15,00 x 8.01 x 83,4	G2			1546437 20817645 20817648 20904074 20905400 20919484 3165303 3183283	<b>81-47119</b>	
	IN/EX [6]	15,00 x 8.02 x 83,2	G2			1546437 20817645 20817648 20904074 20905400 20919484 3165303 3183283	<b>81-47114</b>	
	[12]	M 31 x 68				4210670	<b>20 1004 70000</b>	
<b>79</b>		<b>107</b>	<b>D7C215 Euro 2</b>				01.1998 →	D (LA) 6 7284 cm <sup>3</sup> 2V 158 kW (215 PS) 19:1 135,00 mm
			<b>D7C250 Euro 2</b>				01.1998 →	D (LA) 6 7300 cm <sup>3</sup> 2V 184 kW (250 PS) 19,5:1 135,00 mm
			<b>D7C290 Euro 2</b>				01.1998 →	D (LA) 6 7284 cm <sup>3</sup> 2V 213 kW (290 PS) 19,5:1 135,00 mm
			<b>D7C310 Euro 2</b>				01.1998 →	D (LA) 6 7284 cm <sup>3</sup> 2V 228 kW (310 PS) 19,5:1 135,00 mm
40 308 6..								
	IN [2]	43,0 x 8 x 149,7	S - Cr -	- 30° -	-	9 - III	3978768	<b>48322</b>
	EX [2]	39,0 x 8 x 149,8	RA/S- Cr -	- 45° -	-	9 - III		<b>48326</b> (1)
	(1)	IAM specification						
	[50]	Ø 8 mm					1677875	<b>RK-8H</b>
	IN/EX [6]	15,99 x 8 x 65,5	G1				465157 477792 477877	<b>81-47106</b>
<b>80</b>		<b>107</b>	<b>TAD740GE Euro 1</b>				D (LA) 6 7284 cm <sup>3</sup> 2V 220-251 kW (299-341 PS)	17,2:1 135,00 mm
			<b>TAD741GE Euro 1</b>				D (LA) 6 7284 cm <sup>3</sup> 2V 232 kW (316 PS)	17,2:1 135,00 mm
		01.2000 → 12.2001	D (LA) 6 7284 cm <sup>3</sup> 2V	154-257 kW	(209-349 PS)	17,2:1	135,00 mm	
		01.2000 → 12.2005	D (LA) 6 7284 cm <sup>3</sup> 2V	154-257 kW	(209-349 PS)	17,2:1	135,00 mm	
		2000 → 2001	D (LA) 6 7284 cm <sup>3</sup> 2V	294-331 kW	(400-450 PS)	17,2:1	135,00 mm	
		01.2001 → 12.2005	D (LA) 6 7284 cm <sup>3</sup> 2V	294-331 kW	(400-450 PS)	17,2:1	135,00 mm	
		01.1999 → 12.2001	D (LA) 6 7284 cm <sup>3</sup> 2V	316 kW	(430 PS)	17,2:1	135,00 mm	
		01.2000 → 12.2005	D (LA) 6 7284 cm <sup>3</sup> 2V	316 kW	(430 PS)	17,2:1	135,00 mm	
		01.1998 → 12.2005	D (LA) 6 7284 cm <sup>3</sup> 2V	353 kW	(480 PS)	17,2:1	135,00 mm	
		01.1999 → 12.2002	D (LA) 6 7284 cm <sup>3</sup> 2V	353 kW	(480 PS)	17,2:1	135,00 mm	
			D (LA) 6 7284 cm <sup>3</sup> 2V	178-222 kW	(242-302 PS)	17,2:1	135,00 mm	
40 308 6..								
	IN [2]	43,0 x 8 x 149,7	S - Cr -	- 30° -	-	9 - III	3978768	<b>48322</b>
	[50]	Ø 8 mm					1677875	<b>RK-8H</b>
	IN/EX [6]	15,99 x 8 x 65,5	G1				465157 477792 477877	<b>81-47106</b>
Fortsetzung nächste Seite / continued on next page / suite page suivante / continuación página próxima / Продолжение на следующей странице								

					Reference	Item No.
	IN [2] EX [2]	46,05 x 37.5 x 8,1 42,05 x 32.7 x 8,6	G1 45° G1 45°		477657 477659	92-47021 92-47022
<b>81</b>	<b>107</b>					
<b>TAMD74A</b>	2000 → 2001	D (LA) 6	7284 cm <sup>3</sup> 2V	154-257 kW	(209-349 PS) 17,2:1	135,00 mm
	IN/EX [6]	15,99 x 8 x 65,5	G1		465157 477792 477877	81-47106
	IN [2] EX [2]	46,05 x 37.5 x 8,1 42,05 x 32.7 x 8,6	G1 45° G1 45°		477657 477659	92-47021 92-47022
<b>82</b>	<b>107</b>					
<b>TWD740VE Euro 1</b>		D (LA) 6	7284 cm <sup>3</sup> 2V	151-203 kW	(205-276 PS)	135,00 mm
	IN/EX [6]	15,00 x 8.01 x 83,4	G2		1546437 20817645 20817648 20904074 20905400 20919484 3165303 3183283	81-47119
	IN/EX [6]	15,00 x 8.02 x 83,2	G2		1546437 20817645 20817648 20904074 20905400 20919484 3165303 3183283	81-47114
	IN [2] EX [2]	46,05 x 37.5 x 8,1 42,05 x 32.7 x 8,6	G1 45° G1 45°		477657 477659	92-47021 92-47022
<b>83</b>	<b>108</b>					
<b>D7E 290 Euro 5</b>	01.1991 →	D (LA) 6	7146 cm <sup>3</sup> 4V	213 kW	(290 PS) 18:1	130,00 mm
<b>D7E 360 Euro 4/5</b>		D (LA) 6	7146 cm <sup>3</sup> 4V	265 kW	(360 PS) 18,1	130,00 mm
40 305 6..						
	IN [2] EX [2]	38,2 x 8 x 145,9 35,8 x 8 x 145,9	S - Cr - RA/S- Cr -	- 30° - VS - - 45° - -	22 - III 22 - III	22316 22317
	[50]	∅ 8 mm			20510747 419643	MK-8H
	EX [4]	13,04 x 8 x 58,3	G2		20789674 21705499 22494872	81-22113
	IN [1] EX [1]	39,30 x 31.2 x 7,5 36,80 x 28.4 x 7,5	G1 G1		20833927 21087443 20833930	92-22019 <b>NEW</b> (1) 92-22020 <b>NEW</b> (1)
	(1)	Der Ventilsitz muss endbearbeitet werden. The valve seat must be finished. Les finitions du siège de la soupape doivent être réalisées. Deben realizarse los trabajos finales para el asiento de válvula. Требуется финишная обработка седла клапана.				

					Reference	Item No.	
<b>84</b>		<b>108</b>					
<b>D 5 Euro 2</b>	<b>A-A TA, A-AT</b>						
	01.2002 →	D (LA)	4	4764 cm <sup>3</sup>	4V 77-100 kW (105-136 PS)	17,5:1 130,00 mm	
<b>D 7</b>	<b>A-A TA, A-AT</b>						
	01.2002 →	D (LA)	6	7146 cm <sup>3</sup>	2V 112-148 kW (152-201 PS)	17,5:1 130,00 mm	
<b>D5A-B TA Euro 1</b>							
	01.2008 →	D (LA)	4	4764 cm <sup>3</sup>	2V 89-118 kW (121-160 PS)	17,5:1 130,00 mm	
<b>D5A-T Euro 1</b>							
	01.2002 → 01.2008	D (A)	4	4764 cm <sup>3</sup>	2V 77-81 kW (105-110 PS)	17,5:1 130,00 mm	
<b>D5A-TA Euro 1</b>							
	01.2002 → 01.2008	D (LA)	4	4764 cm <sup>3</sup>	2V 89-118 kW (121-160 PS)	17,5:1 130,00 mm	
<b>TAD520GE Euro 2</b>							
		D (LA)	4	4764 cm <sup>3</sup>	2V 94-110 kW (128-150 PS)	17,5:1 130,00 mm	
<b>TAD520VE Euro 2</b>							
	2002 →	D (LA)	4	4764 cm <sup>3</sup>	2V 107-118 kW (145-160 PS)	18,1-19 130,00 mm	
<b>TAD530GE Euro 2</b>							
	2007 →	D (LA)	4	4764 cm <sup>3</sup>	2V 75-85 kW (102-116 PS)	18:1 130,00 mm	
<b>TAD531GE Euro 2</b>							
	2007 →	D (LA)	4	4764 cm <sup>3</sup>	2V 88-101 kW (120-137 PS)	18:1 130,00 mm	
<b>TAD720GE Euro 2</b>							
	2002 →	D (LA)	6	7145 cm <sup>3</sup>	2V 140-163 kW (190-222 PS)	17,5:1 130,00 mm	
<b>TAD720VE Euro 2</b>							
	2002 →	D (LA)	6	7145 cm <sup>3</sup>	2V 157-174 kW (213-237 PS)	18,4-19 130,00 mm	
<b>TAD721VE Euro 2</b>							
	2002 →	D (LA)	6	7145 cm <sup>3</sup>	2V 176-195 kW (239-265 PS)	18,4-19 130,00 mm	
<b>TAD722VE Euro 2</b>							
	2003 →	D (LA)	6	7145 cm <sup>3</sup>	2V 212-220 kW (288-299 PS)	19:1 130,00 mm	
<b>TAD730GE Euro 2</b>							
	2007 →	D (LA)	6	7145 cm <sup>3</sup>	2V 111-127 kW (151-173 PS)	18:1 130,00 mm	
<b>TAD731GE Euro 2</b>							
	2007 →	D (LA)	6	7145 cm <sup>3</sup>	2V 134-153 kW (182-208 PS)	18:1 130,00 mm	
<b>TD520GE Euro 1</b>							
	01.2001 →	D (A)	4	4764 cm <sup>3</sup>	2V 78-89 kW (106-121 PS)	17,5-19 130,00 mm	
<b>TD520VE Euro 1</b>							
	2002 →	D (A)	4	4764 cm <sup>3</sup>	2V 81 kW (110 PS)	18,4-19 130,00 mm	
<b>TD720GE Euro 1</b>							
	2001 →	D (A)	6	7145 cm <sup>3</sup>	2V 117-134 kW (159-182 PS)	17,5:1 130,00 mm	
<b>TD720VE-PP Euro 1</b>							
		D (A)	6	7145 cm <sup>3</sup>	2V 115 kW (156 PS)	18,4:1 130,00 mm	
41 503 6.., 41 506 6..							
	IN [2]	48,0 x 9 x 139,0	A/S - Cr -	- 30° -	- 22 - III	20405502 20714469	<b>22221</b>
	EX [2]	42,0 x 9 x 139,0	RA/S- Cr -	- 45° -	- 22 - III	20405503 20565912	<b>22220</b>
	[50]	Ø 9 mm					<b>MK-9H</b>
	IN/EX [4]	15,03 x 9.03 x 62,8	G2			20405897 21344665	<b>81-22110</b>
	IN [2]	49,08 x 39 x 7,5	G1 30°			20459962	<b>92-22005</b>
	EX [2]	43,60 x 35 x 7,9	G1 45°			20459963 20845144	<b>92-22006</b>
<b>85</b>		<b>108</b>					
<b>D7A-B TA Euro 1</b>							
	2008 →	D (LA)	6	7145 cm <sup>3</sup>	2V 130-174 kW (177-237 PS)	17,6:1 130,00 mm	
<b>D7A-T Euro 1</b>							
	2002 → 2008	D (A)	6	7145 cm <sup>3</sup>	2V 116-122 kW (158-166 PS)	17,5:1 130,00 mm	
<b>D7A-TA Euro 1</b>							
	2002 → 2008	D (LA)	6	7145 cm <sup>3</sup>	2V 130-174 kW (177-237 PS)	17,5:1 130,00 mm	
<b>D7C-B TA Euro 1</b>							
	2007 →	D (LA)	6	7145 cm <sup>3</sup>	2V 146-195 kW (199-265 PS)	17,6:1 130,00 mm	
<b>D7C-TA Euro 1</b>							
	2004 → 2007	D (LA)	6	7145 cm <sup>3</sup>	2V 146-195 kW (199-265 PS)	17,6:1 130,00 mm	
41 503 6.., 41 506 6..							
Fortsetzung nächste Seite / continued on next page / suite page suivante / continuación página próxima / Продолжение на следующей странице							

					Reference	Item No.	
	IN [2]	48,0 x 9 x 135,5	S - Cr -	- 30° - VS -	22 - III	21896344	<b>22314</b>
	IN [2]	48,0 x 9 x 139,0	A/S - Cr -	- 30° -	22 - III	20405502 20714469	<b>22221</b>
	EX [2]	42,0 x 9 x 135,5	RA/S- Cr -	- 45° -	22 - III	21739130	<b>22315</b>
	EX [2]	42,0 x 9 x 139,0	RA/S- Cr -	- 45° -	22 - III	20405503 20565912	<b>22220</b>
	[50]	Ø 9 mm					<b>MK-9H</b>
	IN/EX [4]	15,03 x 9.03 x 62,8	G2			20405897 21344665	<b>81-22110</b>
	IN [2]	49,08 x 39 x 7,5	G1 30°			20459962	<b>92-22005</b>
	EX [2]	43,60 x 35 x 7,9	G1 45°			20459963 20845144	<b>92-22006</b>

## 86 108

<b>TAD 530</b>	<b>GE EDC4, GE MECH</b>	D (LA)	4	4760 cm <sup>3</sup>	2V	74-85 kW	(101-115 PS)	18:1	130,00 mm
<b>TAD 531</b>	<b>GE EDC4, GE MECH</b>	D (LA)	4	4760 cm <sup>3</sup>	2V	88-104 kW	(119-141 PS)	18:1	130,00 mm
<b>TAD 532</b>	<b>GE EDC4</b>	D (LA)	4	4760 cm <sup>3</sup>	2V	112-129 kW	(152-176 PS)	18:1	130,00 mm
<b>TAD 730</b>	<b>GE EDC4, GE MECH</b>	D (LA)	6	7150 cm <sup>3</sup>	2V	111-127 kW	(151-173 PS)	18:1	130,00 mm
<b>TAD 731</b>	<b>GE EDC4, GE MECH</b>	D (LA)	6	7150 cm <sup>3</sup>	2V	132-156 kW	(180-210 PS)	18:1	130,00 mm
<b>TAD 732</b>	<b>GE EDC4</b>	D (LA)	6	7150 cm <sup>3</sup>	2V	157-192 kW	(214-261 PS)	18:1	130,00 mm
<b>TAD 733</b>	<b>GE EDC4</b>	D (LA)	6	7150 cm <sup>3</sup>	2V	174-213 kW	(236-289 PS)	18:1	130,00 mm
<b>TD 720 Euro 1</b>	<b>VE</b>	D (LA)	6	7146 cm <sup>3</sup>	4V	122 kW	(166 PS)	18,4:1	130,00 mm

41 503 6..

	IN/EX [4]	15,03 x 9.03 x 62,8	G2			20405897 21344665			<b>81-22110</b>
	IN [2]	49,08 x 39 x 7,5	G1 30°			20459962			<b>92-22005</b>
	EX [2]	43,60 x 35 x 7,9	G1 45°			20459963 20845144			<b>92-22006</b>

## 87 108

<b>TAD532GE Euro 2</b>	2007 →	D (LA)	4	4764 cm <sup>3</sup>	2V	113-126 kW	(154-171 PS)	18:1	130,00 mm
<b>TAD550GE Euro 3</b>		D (LA)	4	4764 cm <sup>3</sup>	2V	76-94 kW	(103-128 PS)	18:1	130,00 mm
<b>TAD551GE Euro 3</b>		D (LA)	4	4764 cm <sup>3</sup>	2V	89-110 kW	(121-150 PS)	18:1	130,00 mm
<b>TAD721GE Euro 2</b>	2002 →	D (LA)	6	7145 cm <sup>3</sup>	2V	162-197 kW	(220-268 PS)	18,1:1	130,00 mm
<b>TAD722GE Euro 2</b>	2002 →	D (LA)	6	7145 cm <sup>3</sup>	2V	179-218 kW	(243-296 PS)	18,1:1	130,00 mm
<b>TAD732GE Euro 2</b>	2007 →	D (LA)	6	7145 cm <sup>3</sup>	2V	159-192 kW	(216-261 PS)	18:1	130,00 mm
<b>TAD733GE Euro 2</b>	2007 →	D (LA)	6	7145 cm <sup>3</sup>	2V	176-213 kW	(239-290 PS)	18:1	130,00 mm
<b>TAD750GE Euro 3</b>		D (LA)	6	7145 cm <sup>3</sup>	2V	113-141 kW	(154-192 PS)	18,1:1	130,00 mm
<b>TAD750VE Euro 3</b>	2006 →	D (LA)	6	7145 cm <sup>3</sup>	2V	170-200 kW	(231-272 PS)	18,0:1	130,00 mm
<b>TAD751GE Euro 3</b>		D (LA)	6	7145 cm <sup>3</sup>	2V	132-166 kW	(179-226 PS)	18,0:1	130,00 mm
<b>TAD760VE Euro 3</b>	2006 →	D (LA)	6	7145 cm <sup>3</sup>	2V	180 kW	(245 PS)	18,1:1	130,00 mm

41 504 6.., 41 505 6..

	IN [2]	48,0 x 9 x 135,5	S - Cr -	- 30° - VS -	22 - III	21896344			<b>22314</b>
	EX [2]	42,0 x 9 x 135,5	RA/S- Cr -	- 45° -	22 - III	21739130			<b>22315</b>
	[50]	Ø 9 mm							<b>MK-9H</b>
	IN/EX [4]	15,03 x 9.03 x 62,8	G2			20405897 21344665			<b>81-22110</b>

Fortsetzung nächste Seite / continued on next page / suite page suivante / continuación página próxima / Продолжение на следующей странице

					Reference	Item No.
IN [2] EX [2]	49,08 x 39 x 7,5 43,60 x 35 x 7,9	G1 30° G1 45°			20459962 20459963 20845144	<b>92-22005</b> <b>92-22006</b>

## 88 108

<b>D7E 240 Euro 4</b>	05.2006 →	D (LA) 6	7146 cm <sup>3</sup>	4V	177 kW	(240 PS)	18:1	130,00 mm
<b>D7E 280 Euro 4/5</b>	05.2006 →	D (LA) 6	7146 cm <sup>3</sup>	4V	206 kW	(280 PS)	18:1	130,00 mm
<b>D7E 320 Euro 4/5</b>	05.2006 →	D (LA) 6	7146 cm <sup>3</sup>	4V	235 kW	(320 PS)	18:1	130,00 mm

40 305 6..

IN [2] EX [2]	38,2 x 8 x 145,9 35,8 x 8 x 145,9	S - Cr - RA/S- Cr -	- 30° - VS - - 45° - -	22 - III 22 - III	20833932 20980413 21894469 20833936 20997871	<b>22316</b> <b>22317</b>
[50]	Ø 8 mm				20510747 419643	<b>MK-8H</b>
EX [4]	13,04 x 8 x 58,3	G2			20789674 21705499 22494872	<b>81-22113</b>
IN [1] EX [1]	39,30 x 31.2 x 7,5 36,80 x 28.4 x 7,5	G1 G1			20833927 21087443 20833930	<b>92-22019</b> (1) <b>92-22020</b> (1)
<p>(1) Der Ventilsitz muss endbearbeitet werden. The valve seat must be finished. Les finitions du siège de la soupape doivent être réalisées. Deben realizarse los trabajo finales para el asiento de válvula. Требуется финишная обработка седла клапана.</p>						
					20795692 20795696 21311517 21341222 21426367 21451261	<b>20 1004 07100</b>

## 89 108

<b>TAD560VE</b>		D (LA) 4	4764 cm <sup>3</sup>	4V	129 kW	(175 PS)	17,3:1	130,00 mm
<b>TAD561VE</b>		D (LA) 4	4764 cm <sup>3</sup>	4V	155 kW	(211 PS)	17,3:1	130,00 mm
<b>TAD734GE Euro 2</b>	2007 →	D (LA) 6	7145 cm <sup>3</sup>	4V	219-247 kW	(298-336 PS)	17:1	130,00 mm
<b>TAD752GE Euro 3</b>		D (LA) 6	7145 cm <sup>3</sup>	4V	158-196 kW	(215-266 PS)	18,1:1	130,00 mm
<b>TAD753GE Euro 3</b>		D (LA) 6	7145 cm <sup>3</sup>	4V	175-218 kW	(238-296 PS)	18,1:1	130,00 mm
<b>TAD754GE Euro 3</b>		D (LA) 6	7145 cm <sup>3</sup>	4V	219-245 kW	(298-333 PS)	17,0:1	130,00 mm
<b>TAD761VE Euro 3</b>		D (LA) 6	7145 cm <sup>3</sup>	4V	160 kW	(218 PS)	17,3:1	130,00 mm
<b>TAD762VE Euro 3</b>		D (LA) 6	7145 cm <sup>3</sup>	4V	185 kW	(252 PS)	17,3:1	130,00 mm
<b>TAD763VE Euro 3</b>		D (LA) 6	7145 cm <sup>3</sup>	4V	210 kW	(286 PS)	17,3:1	130,00 mm
<b>TAD764VE Euro 3</b>		D (LA) 6	7145 cm <sup>3</sup>	4V	225 kW	(306 PS)	17,3:1	130,00 mm
<b>TAD765VE Euro 3</b>		D (LA) 6	7145 cm <sup>3</sup>	4V	235 kW	(320 PS)	17,3:1	130,00 mm

40 305 6.., 41 502 6..

IN [2] EX [2]	38,2 x 8 x 145,9 35,8 x 8 x 145,9	S - Cr - RA/S- Cr -	- 30° - VS - - 45° - -	22 - III 22 - III	20833932 20980413 21894469 20833936 20997871	<b>22316</b> <b>22317</b>
[50]	Ø 8 mm				20510747 419643	<b>MK-8H</b>
EX [4]	13,04 x 8 x 58,3	G2			20789674 21705499 22494872	<b>81-22113</b>
IN [1] EX [1]	39,30 x 31.2 x 7,5 36,80 x 28.4 x 7,5	G1 G1			20833927 21087443 20833930	<b>92-22019</b> (1) <b>92-22020</b> (1)

Fortsetzung nächste Seite / continued on next page / suite page suivante / continuación página próxima / Продолжение на следующей странице

					Reference	Item No.
(1)	Der Ventilsitz muss endbearbeitet werden. The valve seat must be finished. Les finitions du siège de la soupape doivent être réalisées. Deben realizarse los trabajos finales para el asiento de válvula. Требуется финишная обработка седла клапана.					
[1]	M 25 x 50				21456499 21486078 22176515	<b>20 0105 10140</b>

## 90 108

**D7D EAE2**

D (LA) 6 7146 cm<sup>3</sup> 4V 143-153 kW (194-208 PS) 130,00 mm

41 504 6..

IN [2]	48,0 x 9 x 139,0	A/S - Cr -	- 30° - -	22 - III	20405502 20714469	<b>22221</b>
EX [2]	42,0 x 9 x 139,0	RA/S- Cr -	- 45° - -	22 - III	20405503 20565912	<b>22220</b>
[50]	Ø 9 mm					<b>MK-9H</b>

## 91 110

<b>D5K240 Euro 6</b>	05.2013 →	D (LA) 4	5132 cm <sup>3</sup> 4V	176-177 kW	(239-241 PS)	17,5:1	135,00 mm
<b>D8K250 Euro 6</b>	05.2012 →	D (LA) 6	7698 cm <sup>3</sup> 4V	184 kW	(250 PS)	17,5:1	135,00 mm
<b>D8K280 Euro 6</b>	05.2012 →	D (LA) 6	7698 cm <sup>3</sup> 4V	206 kW	(280 PS)	17,5:1	135,00 mm
<b>D8K320 Euro 6</b>	05.2012 →	D (LA) 6	7698 cm <sup>3</sup> 4V	235 kW	(320 PS)	17,5:1	135,00 mm
<b>D8K350 Euro 6</b>	08.2016 →	D (LA) 6	7698 cm <sup>3</sup> 4V	258 kW	(350 PS)	17,5:1	135,00 mm
<b>TAD540VE Euro 2</b>		D (LA) 4	5132 cm <sup>3</sup> 4V	105 kW	(143 PS)	17,5:1	135,00 mm
<b>TAD541VE Euro 2</b>		D (LA) 4	5132 cm <sup>3</sup> 4V	129 kW	(175 PS)	17,5:1	135,00 mm
<b>TAD542VE Euro 2</b>		D (LA) 4	5132 cm <sup>3</sup> 4V	160 kW	(218 PS)	17,5:1	135,00 mm
<b>TAD550VE Euro 3</b>		D (LA) 4	5132 cm <sup>3</sup> 4V	105 kW	(143 PS)	17,5	135,00 mm
<b>TAD551VE Euro 3</b>		D (LA) 4	5132 cm <sup>3</sup> 4V	129 kW	(175 PS)	17,5	135,00 mm
<b>TAD552VE Euro 3</b>		D (LA) 4	5132 cm <sup>3</sup> 4V	160 kW	(218 PS)	17,5	135,00 mm
<b>TAD570VE Euro 4</b>		D (LA) 4	5132 cm <sup>3</sup> 4V	105 kW	(143 PS)	17,5:1	135,00 mm
<b>TAD571VE Euro 4</b>		D (LA) 4	5132 cm <sup>3</sup> 4V	129 kW	(175 PS)	17,5:1	135,00 mm
<b>TAD572VE Euro 4</b>		D (LA) 4	5132 cm <sup>3</sup> 4V	160 kW	(218 PS)	17,5:1	135,00 mm
<b>TAD840VE Euro 2</b>		D (LA) 6	7698 cm <sup>3</sup> 4V	160 kW	(218 PS)	17,5:1	135,00 mm
<b>TAD841VE Euro 2</b>		D (LA) 6	7698 cm <sup>3</sup> 4V	185 kW	(252 PS)	17,5:1	135,00 mm
<b>TAD842VE Euro 2</b>		D (LA) 6	7698 cm <sup>3</sup> 4V	210 kW	(286 PS)	17,5:1	135,00 mm
<b>TAD843VE Euro 2</b>		D (LA) 6	7698 cm <sup>3</sup> 4V	235 kW	(320 PS)	17,5:1	135,00 mm
<b>TAD851VE Euro 3</b>		D (LA) 6	7698 cm <sup>3</sup> 4V	185 kW	(252 PS)	17,5:1	135,00 mm
<b>TAD852VE Euro 3</b>		D (LA) 6	7698 cm <sup>3</sup> 4V	210 kW	(286 PS)	17,5:1	135,00 mm
<b>TAD853VE Euro 3</b>		D (LA) 6	7698 cm <sup>3</sup> 4V	235 kW	(320 PS)	17,5:1	135,00 mm
<b>TAD870VE Euro 4</b>		D (LA) 6	7698 cm <sup>3</sup> 4V	160 kW	(218 PS)	17,5:1	135,00 mm
<b>TAD871VE Euro 4</b>		D (LA) 6	7698 cm <sup>3</sup> 4V	185 kW	(252 PS)	17,5:1	135,00 mm
<b>TAD872VE Euro 4</b>		D (LA) 6	7698 cm <sup>3</sup> 4V	210 kW	(286 PS)	17,5:1	135,00 mm
<b>TAD873VE Euro 4</b>		D (LA) 6	7698 cm <sup>3</sup> 4V	235 kW	(320 PS)	17,5:1	135,00 mm

41 263 6..

IN [2]	38,0 x 8 x 136,6	O - Ni -	- 35° - -	1 - III	21528642 22583038	<b>48335</b> <small>NEW</small>
EX [2]	35,0 x 8 x 139,6	RA/S- Cr -	- 45° - VS -	1 - III	21528644 21528645	<b>48336</b> <small>NEW</small>
[50]	Ø 8 mm				8420816 8420816-4	<b>KK-8H</b>
IN/EX [1]	12,03 x 8 x 50,0	G2			22103846	<b>81-47123</b> <small>NEW</small>



					Reference	Item No.	
<b>92</b>		<b>110</b>					
<b>D8A1-A MP Euro 2</b>		D	6	7700 cm <sup>3</sup>	4V	661 kW (550 PS) 16,5:1	135,00 mm
<b>D8A4-A MP Euro 2</b>		D	6	7700 cm <sup>3</sup>	4V	16,5:1	135,00 mm
<b>TAD 850 Euro 3</b>	<b>VE</b>	D	6	7700 cm <sup>3</sup>	4V	160 kW (218 PS) 17,5	135,00 mm
<b>TAD 880 Euro 5</b>	<b>VE</b>	D	6	7700 cm <sup>3</sup>	4V	160 kW (218 PS) 17,2	135,00 mm
<b>TAD 881 Euro 5</b>	<b>VE</b>	D	6	7700 cm <sup>3</sup>	4V	185 kW (252 PS) 17,2	135,00 mm
<b>TAD 882 Euro 5</b>	<b>VE</b>	D	6	7700 cm <sup>3</sup>	4V	210 kW (286 PS) 17,2	135,00 mm
<b>TAD 883 Euro 5</b>	<b>VE</b>	D	6	7700 cm <sup>3</sup>	4V	235 kW (320 PS) 17,2	135,00 mm
<b>TAD 884 Euro 5</b>	<b>VE</b>	D	6	7700 cm <sup>3</sup>	4V	250 kW (340 PS) 17,2	135,00 mm
	IN/EX [1]	12,03 x 8 x 50,0	G2			22103846	<b>81-47123</b> <small>NEW</small>
<b>93</b>		<b>120</b>					
<b>D9B260 Euro 5</b>	09.2005 →	D (LA)	6	9364 cm <sup>3</sup>	4V	191-194 kW (260-264 PS) 18,5:1	138,00 mm
<b>D9B300 Euro 4</b>	09.2005 →	D (LA)	6	9364 cm <sup>3</sup>	4V	221 kW (300 PS) 18,5:1	138,00 mm
<b>D9B310 Euro 5</b>	09.2005 →	D (LA)	6	9364 cm <sup>3</sup>	4V	228 kW (310 PS) 18,5:1	138,00 mm
<b>D9B340 Euro 4</b>	09.2005 →	D (LA)	6	9364 cm <sup>3</sup>	4V	250 kW (340 PS) 18,5:1	138,00 mm
<b>D9B360 Euro 4/5</b>	01.1999 →	D (LA)	6	9364 cm <sup>3</sup>	4V	265 kW (360 PS) 18,5:1	138,00 mm
<b>D9B380 Euro 4</b>	09.2005 →	D (LA)	6	9364 cm <sup>3</sup>	4V	280 kW (380 PS) 18,5:1	138,00 mm
41 162 6..							
	IN [2]	38,0 x 8 x 191,9	RA/S- Cr -	- 30° - VS -	22 - III	20528113 20551761	<b>48310</b>
	EX [2]	36,0 x 8 x 192,7	RA/S- Cr -	- 30° - VS -	22 - III	20564039 21430916	<b>48312</b>
	[50]	∅ 8 mm				20510747 419643	<b>MK-8H</b>
	IN/EX [6]	15,00 x 8.01 x 83,4	G2			1546437 20817645 20817648 20904074 20905400 20919484 3165303 3183283	<b>81-47119</b>
	IN/EX [6]	15,00 x 8.02 x 83,2	G2			1546437 20817645 20817648 20904074 20905400 20919484 3165303 3183283	<b>81-47114</b>
<b>94</b>		<b>120</b>					
<b>D 9 Euro 2</b>	<b>A2A</b>						
	2004 → 2006	D (LA)	6	9364 cm <sup>3</sup>	4V	221-313 kW (300-425 PS) 20,2:1	138,00 mm
<b>D9A260 Euro 3</b>	12.2001 → 09.2005	D (LA)	6	9364 cm <sup>3</sup>	4V	191 kW (260 PS) 18,6:1	138,00 mm
<b>D9A300 Euro 3</b>	12.2001 →	D (LA)	6	9364 cm <sup>3</sup>	4V	221-224 kW (300-305 PS) 18,6:1	138,00 mm
<b>D9A340 Euro 3</b>	12.2001 →	D (LA)	6	9364 cm <sup>3</sup>	4V	250-251 kW (340-341 PS) 18,6:1	138,00 mm
<b>D9A380 Euro 3</b>	12.2001 → 09.2005	D (LA)	6	9364 cm <sup>3</sup>	4V	279 kW (380 PS) 18,6:1	138,00 mm
40 276 6.., 41 166 6.., 41 658 6..							
Fortsetzung nächste Seite / continued on next page / suite page suivante / continuación página próxima / Продолжение на следующей странице							

V

					Reference	Item No.
	IN [2] 38,0 x 8 x 191,9	RA/S- Cr -	- 30° - VS -	22 - III	20528113 20551761	<b>48310</b>
	IN [2] 38,0 x 8 x 192,0	RA/S- Cr -	- 30° - VS -	9 - III	20450002 20528110 20528111	<b>48308</b>
	EX [2] 38,0 x 8 x 191,6	RA/S- Cr -	- 30° - VS -	22 - III	20570965	<b>48311</b>
	EX [2] 38,0 x 8 x 191,7	RA/S- Cr -	- 30° - VS -	9 - III	20516141 8148069	<b>48309</b>
	[50] ∅ 8 mm				20510747 419643	<b>MK-8H</b>
	[50] ∅ 8 mm				1677875	<b>RK-8H</b>
	IN/EX [6] 15,00 x 8.01 x 83,4	G2			1546437 20817645 20817648 20904074 20905400 20919484 3165303 3183283	<b>81-47119</b>
	IN/EX [6] 15,00 x 8.02 x 83,2	G2			1546437 20817645 20817648 20904074 20905400 20919484 3165303 3183283	<b>81-47114</b>
	IN [2] 40,05 x 31 x 7,4	G1 30°			20555102	<b>92-47023</b>
	EX [2] 41,05 x 31 x 7,4	G1 30°			20555104	<b>92-47024</b>
					20451775 20451774	<b>20 1004 09000</b> (1) <b>20 1004 09001</b> (2)
	<p>(1) EBR-EPG Motorbremstyp - Auspuffdrucklager/engine brake type - exhaust thrust bearing/type de frein moteur - butée d'embrayage/tipo de freno del motor: cojinete de empuje de gases de escape/Тип моторного тормоза — упорный подшипник системы выпуска</p> <p>(2) EBR-VEB7 Motorbremstyp - Volvo Motorbremse einschließlich Auspuffdrucklager/engine brake type - Volvo engine brake including exhaust thrust bearing/type de frein moteur - frein moteur Volvo avec butée d'embrayage/Tipo de freno del motor: freno del motor Volvo incluido cojinete de empuje de gases de escape/Тип моторного тормоза — моторный тормоз Volvo вместе с упорным подшипником системы выпуска</p>					

## 95 120

**D 9 Euro 2**

**A2A MG, A2B, A2C, A2D, A2E, A2F**

2004 →

D (LA)

6

9364 cm<sup>3</sup> 4V

221-423 kW

(300-575 PS)

138,00 mm

41 166 6.., 41 658 6..

	IN [2] 38,0 x 8 x 191,9	RA/S- Cr -	- 30° - VS -	22 - III	20528113 20551761	<b>48310</b>
	IN [2] 38,0 x 8 x 192,0	RA/S- Cr -	- 30° - VS -	9 - III	20450002 20528110 20528111	<b>48308</b>
	EX [2] 38,0 x 8 x 191,6	RA/S- Cr -	- 30° - VS -	22 - III	20570965	<b>48311</b>
	EX [2] 38,0 x 8 x 191,7	RA/S- Cr -	- 30° - VS -	9 - III	20516141 8148069	<b>48309</b>
	[50] ∅ 8 mm				20510747 419643	<b>MK-8H</b>
	[50] ∅ 8 mm				1677875	<b>RK-8H</b>

Fortsetzung nächste Seite / continued on next page / suite page suivante / continuación página próxima / Продолжение на следующей странице

					Reference	Item No.
	IN/EX [6] 15,00 x 8.01 x 83,4	G2			1546437 20817645 20817648 20904074 20905400 20919484 3165303 3183283	81-47119
	IN/EX [6] 15,00 x 8.02 x 83,2	G2			1546437 20817645 20817648 20904074 20905400 20919484 3165303 3183283	81-47114
	IN [2] 40,05 x 31 x 7,4 EX [2] 41,05 x 31 x 7,4	G1 30° G1 30°			20555102 20555104	92-47023 92-47024
					20451775	20 1004 09000 (1)
(1) EBR-EPG Motorbremsentyp - Auspuffdrucklager/engine brake type - exhaust thrust bearing/type de frein moteur - butée d'embrayage/tipo de freno del motor: cojinete de empuje de gases de escape/ Тип моторного тормоза — упорный подшипник системы выпуска						

**96**

**TAD940GE Euro 2** 2004 → D (LA) 6 9364 cm<sup>3</sup> 4V 240-273 kW (326-371 PS) 20,2:1 138,00 mm  
41 166 6..

	IN [2] 38,0 x 8 x 191,9 EX [2] 38,0 x 8 x 191,6	RA/S- Cr - RA/S- Cr -	- 30° - VS - - 30° - VS -	22 - III 22 - III	20528113 20551761 20570965	48310 48311
	[50] Ø 8 mm				20510747 419643	MK-8H
	IN/EX [6] 15,00 x 8.01 x 83,4	G2			1546437 20817645 20817648 20904074 20905400 20919484 3165303 3183283	81-47119
	IN/EX [6] 15,00 x 8.02 x 83,2	G2			1546437 20817645 20817648 20904074 20905400 20919484 3165303 3183283	81-47114
					20451775	20 1004 09000 (1)
(1) EBR-EPG Motorbremsentyp - Auspuffdrucklager/engine brake type - exhaust thrust bearing/type de frein moteur - butée d'embrayage/tipo de freno del motor: cojinete de empuje de gases de escape/ Тип моторного тормоза — упорный подшипник системы выпуска						

**97**

**TAD940VE Euro 2** 2004 → D (LA) 6 9364 cm<sup>3</sup> 4V 171-190 kW (232-258 PS) 20,2:1 138,00 mm  
**TAD941VE Euro 2** 2004 → D (LA) 6 9364 cm<sup>3</sup> 4V 201-220 kW (273-299 PS) 20,2:1 138,00 mm  
**TAD942VE Euro 2** 2004 → D (LA) 6 9364 cm<sup>3</sup> 4V 235-250 kW (320-340 PS) 20,2:1 138,00 mm  
**TAD943VE Euro 2** 2004 → D (LA) 6 9364 cm<sup>3</sup> 4V 236-279 kW (321-379 PS) 20,2:1 138,00 mm  
 41 166 6..

Fortsetzung nächste Seite / continued on next page / suite page suivante / continuación página próxima / Продолжение на следующей странице

					Reference	Item No.
IN [2]	38,0 x 8 x 192,0	RA/S- Cr -	- 30° - VS -	9 - III	20450002 20528110 20528111	<b>48308</b>
EX [2]	38,0 x 8 x 191,7	RA/S- Cr -	- 30° - VS -	9 - III	20516141 8148069	<b>48309</b>
[50]	Ø 8 mm				1677875	<b>RK-8H</b>
IN/EX [6]	15,00 x 8.01 x 83,4	G2			1546437 20817645 20817648 20904074 20905400 20919484 3165303 3183283	<b>81-47119</b>
IN/EX [6]	15,00 x 8.02 x 83,2	G2			1546437 20817645 20817648 20904074 20905400 20919484 3165303 3183283	<b>81-47114</b>
					20451775	<b>20 1004 09000 (1)</b>
(1) EBR-EPG Motorbremsentyp - Auspuffdrucklager/engine brake type - exhaust thrust bearing/type de frein moteur - butée d'embrayage/tipo de freno del motor: cojinete de empuje de gases de escape/ Тип моторного тормоза — упорный подшипник системы выпуска						

## 98 120

**TAD941GE Euro 2** 2004 → D (LA) 6 9364 cm<sup>3</sup> 4V 281-323 kW (382-439 PS) 17,4:1 138,00 mm  
41 658 6..

IN [2]	38,0 x 8 x 191,9	RA/S- Cr -	- 30° - VS -	22 - III	20528113 20551761	<b>48310</b>
EX [2]	38,0 x 8 x 192,7	RA/S- Cr -	- 30° - VS -	22 - III	20464020 20564019 20564020 21430918 22686466 3842972	<b>48314</b>
[50]	Ø 8 mm				20510747 419643	<b>MK-8H</b>
IN/EX [6]	15,00 x 8.01 x 83,4	G2			1546437 20817645 20817648 20904074 20905400 20919484 3165303 3183283	<b>81-47119</b>
IN/EX [6]	15,00 x 8.02 x 83,2	G2			1546437 20817645 20817648 20904074 20905400 20919484 3165303 3183283	<b>81-47114</b>
					20451775	<b>20 1004 09000 (1)</b>

Fortsetzung nächste Seite / continued on next page / suite page suivante / continuación página próxima / Продолжение на следующей странице

					Reference	Item No.
(1)	EBR-EPG Motorbremstyp - Auspuffdrucklager/engine brake type - exhaust thrust bearing/type de frein moteur - butée d'embrayage/tipo de freno del motor: cojinete de empuje de gases de escape/ Тип моторного тормоза — упорный подшипник системы выпуска					

<b>99</b>		<b>120</b>				
<b>TAD950VE Euro 3</b>	2005 →	D (LA) 6	9364 cm <sup>3</sup>	4V	178-191 kW (242-260 PS)	20,2:1 138,00 mm
<b>TAD951VE Euro 3</b>	2005 →	D (LA) 6	9364 cm <sup>3</sup>	4V	205-224 kW (279-305 PS)	20,2:1 138,00 mm
<b>TAD952VE Euro 3</b>	2005 →	D (LA) 6	9364 cm <sup>3</sup>	4V	234-252 kW (318-343 PS)	20,2:1 138,00 mm
41 657 6..						

	IN [2]	38,0 x 8 x 191,9	RA/S- Cr -	- 30° - VS -	22 - III	20528113 20551761	<b>48310</b>
	EX [2]	36,0 x 8 x 192,7	RA/S- Cr -	- 30° - VS -	22 - III	20564039 21430916	<b>48312</b>
	[50]	Ø 8 mm				20510747 419643	<b>MK-8H</b>
	IN/EX [6]	15,00 x 8.01 x 83,4	G2			1546437 20817645 20817648 20904074 20905400 20919484 3165303 3183283	<b>81-47119</b>
	IN/EX [6]	15,00 x 8.02 x 83,2	G2			1546437 20817645 20817648 20904074 20905400 20919484 3165303 3183283	<b>81-47114</b>
						20451775	<b>20 1004 09000 (1)</b>
(1)	EBR-EPG Motorbremstyp - Auspuffdrucklager/engine brake type - exhaust thrust bearing/type de frein moteur - butée d'embrayage/tipo de freno del motor: cojinete de empuje de gases de escape/ Тип моторного тормоза — упорный подшипник системы выпуска						

<b>100</b>		<b>120</b>				
<b>D 9 Euro 2</b>		<b>A2G 425, A2G 500, A2H 500, A2H 575, A2J 425, A2K 500, A2K 575</b>				
	01.2008 →	D (LA) 6	9364 cm <sup>3</sup>	4V	313-423 kW (425-575 PS)	138,00 mm
41 166 6.., 41 658 6..						

	IN/EX [6]	15,00 x 8.02 x 83,2	G2			1546437 20817645 20817648 20904074 20905400 20919484 3165303 3183283	<b>81-47114</b>
--	-----------	---------------------	----	--	--	---	-----------------

<b>101</b>		<b>120</b>				
<b>D 9 Euro 2</b>		<b>A2A 500, A2A 575, A2B 425</b>				
		D (LA) 6	9364 cm <sup>3</sup>	4V	313-423 kW (425-575 PS)	20,2:1 138,00 mm
41 166 6..						

Fortsetzung nächste Seite / continued on next page / suite page suivante / continuación página próxima / Продолжение на следующей странице						
--	--	--	--	--	--	--

					Reference	Item No.
IN [2]	38,0 x 8 x 191,9	RA/S- Cr -	- 30° - VS -	22 - III	20528113 20551761	<b>48310</b>
IN [2]	38,0 x 8 x 192,0	RA/S- Cr -	- 30° - VS -	9 - III	20450002 20528110 20528111	<b>48308</b>
EX [2]	38,0 x 8 x 191,6	RA/S- Cr -	- 30° - VS -	22 - III	20570965	<b>48311</b>
EX [2]	38,0 x 8 x 191,7	RA/S- Cr -	- 30° - VS -	9 - III	20516141 8148069	<b>48309</b>
[50]	∅ 8 mm				20510747 419643	<b>MK-8H</b>
[50]	∅ 8 mm				1677875	<b>RK-8H</b>
IN/EX [6]	15,00 x 8.01 x 83,4	G2			1546437 20817645 20817648 20904074 20905400 20919484 3165303 3183283	<b>81-47119</b>
IN/EX [6]	15,00 x 8.02 x 83,2	G2			1546437 20817645 20817648 20904074 20905400 20919484 3165303 3183283	<b>81-47114</b>
IN [2]	40,05 x 31 x 7,4	G1 30°			20555102	<b>92-47023</b>
EX [2]	41,05 x 31 x 7,4	G1 30°			20555104	<b>92-47024</b>

## 102 120

<b>TAD 1030 Euro 1</b>	<b>GE</b>	D (LA)	6	9600 cm <sup>3</sup>	2V	222-258 kW	(302-351 PS)	17:1	140,00 mm
<b>TAD 1032</b>	<b>GE</b>	D (LA)	6	9600 cm <sup>3</sup>	2V	240-262 kW	(326-356 PS)	17:1	140,00 mm

IN [6]	17,98 x 11 x 82,0	G2					<b>81-47117</b>
IN [6]	18,03 x 11 x 82,0	G1			422320		<b>81-47109</b>
EX [6]	18,00 x 11 x 66,0	G1			1545135 421297		<b>81-47104</b>
EX [1]	18,00 x 11 x 66,0	G1			11129092		<b>81-47124</b> <small>NEW</small>
IN [2]	54,06 x 44.35 x 6,7	G1 30°			06-0256 467474		<b>92-47011</b>
IN [2]	54,26 x 44.35 x 6,9	G1 30°			06-0405 467590		<b>92-47012</b>
EX [2]	49,09 x 40 x 9,4	G1 45°			1545886		<b>92-47015</b>
EX [2]	49,29 x 40 x 9,6	G1 45°			1545885		<b>92-47016</b>

## 103 120,65

<b>D 100</b>	<b>BHC, BRC, HC</b>	D	6	9600 cm <sup>3</sup>	2V	122-147 kW	(166-200 PS)	17:1	140,00 mm
--------------	---------------------	---	---	----------------------	----	------------	--------------	------	-----------

91 360 6..

Fortsetzung nächste Seite / continued on next page / suite page suivante / continuación página próxima / Продолжение на следующей странице



					Reference	Item No.
IN [1]	50,0 x 11 x 167,4	S - Cr -	- 30° - -	9 - III	154 52 90 467502 467502-1 4675021 479204 479205	<b>105-35037</b>
EX [1]	46,0 x 11 x 167,2	RA/S- Cr -	- 45° - VS -	9 - III	467503 467682 467855 467855-3 4678553 8194224	<b>48151</b>
EX [1] (1) IAM specification	46,0 x 11 x 167,3	A/S - Cr -	- 45° - -	9 - III		<b>48300</b> (1)
[50]	Ø 11 mm				468305	<b>RK-11H</b>
IN [6]	17,98 x 11 x 82,0	G2				<b>81-47117</b>
IN [6]	18,03 x 11 x 82,0	G1			422320	<b>81-47109</b>
EX [6]	18,00 x 11 x 66,0	G1			1545135 421297	<b>81-47104</b>
EX [1]	18,00 x 11 x 66,0	G1			11129092	<b>81-47124</b> <span style="border: 1px solid black; padding: 1px;">NEW</span>
IN [2]	54,06 x 44.35 x 6,7	G1 30°			06-0256 467474	<b>92-47011</b>
IN [2]	54,26 x 44.35 x 6,9	G1 30°			06-0405 467590	<b>92-47012</b>
EX [1]	49,08 x 40 x 11,4	G1 45°			06-0258 467475	<b>92-47013</b>
[12]	M 36 x 72				15455397 15455405 4223186 4790317 4798633	<b>20 1004 12001</b>
[12]	M 36 x 72				1535539	<b>20 1004 12003</b>

## 104 120,65

<b>HD 100</b>	<b>D</b>								
	08.1972 → 03.1980	D (NA)	6	9600 cm <sup>3</sup>	2V	125-132 kW	(170-180 PS)	17:1	140,00 mm
<b>TD 100</b>	<b>AG, AHC, ARC, B, BG, F, GG</b>								
	01.1965 →	D (A)	6	9600 cm <sup>3</sup>	2V	137-220 kW	(186-299 PS)		140,00 mm
<b>TD 101</b>	<b>G</b>								
	01.1980 → 09.2001	D (A)	6	9600 cm <sup>3</sup>	2V	192-202 kW	(261-275 PS)	14,3:1	140,00 mm
<b>TD 101</b>	<b>F, FA, FC, FD, GA</b>								
	01.1965 →	D (LA)	6	9600 cm <sup>3</sup>	2V	200-222 kW	(272-302 PS)	14,3:1	140,00 mm
<b>TD 102</b>	<b>FDQ, FF, FH, FM, FQ</b>								
	09.1985 →	D (LA)	6	9600 cm <sup>3</sup>	2V	210-252 kW	(286-343 PS)		140,00 mm
<b>TD 102 Euro 1</b>	<b>FL</b>								
	01.1987 →	D (A)	6	9600 cm <sup>3</sup>	2V	234 kW	(318 PS)	16:1	140,00 mm
<b>TD 102 Euro 1</b>	<b>F, FD</b>								
	01.1987 →	D (LA)	6	9600 cm <sup>3</sup>	2V	230-234 kW	(313-318 PS)	15:1	140,00 mm
<b>TD 103 Euro 1</b>	<b>E</b>								
	09.1985 → 02.1996	D (LA)	6	9600 cm <sup>3</sup>	2V	210-235 kW	(286-320 PS)	18:1	140,00 mm
<b>TD 103 Euro 1</b>	<b>EA, ES</b>								
	09.1985 →	D (A)	6	9600 cm <sup>3</sup>	2V	210-235 kW	(286-320 PS)	18:1	140,00 mm
<b>THD 100</b>									
	10.1979 → 12.1983	D (A)	6	9600 cm <sup>3</sup>	2V			15:1	140,00 mm
<b>THD 101</b>	<b>G, GB, GC, GD</b>								
	06.1981 →	D (A)	6	9600 cm <sup>3</sup>	2V	160-234 kW	(218-318 PS)	15:1	140,00 mm
<b>THD 101</b>	<b>K, KB, KC</b>								
		D (LA)	6	9600 cm <sup>3</sup>	2V	203-228 kW	(276-310 PS)	15:1	140,00 mm
<b>TMD 100</b>	<b>A</b>								
	1969 → 1974	D (A)	6	9600 cm <sup>3</sup>	2V	143-194 kW	(195-264 PS)	17:1	140,00 mm

91 359 6.., 91 360 6.., 93 660 6.., 93 734 6.., 99 750 6..

Fortsetzung nächste Seite / continued on next page / suite page suivante / continuación página próxima / Продолжение на следующей странице

					Reference	Item No.
IN [1]	50,0 x 11 x 167,4	S - Cr -	- 30° - -	9 - III	154 52 90 467502 467502-1 4675021 479204 479205	<b>105-35037</b>
EX [1]	46,0 x 11 x 167,2	RA/S- Cr -	- 45° - VS -	9 - III	467503 467682 467855 467855-3 4678553 8194224	<b>48151</b>
EX [1] (1) IAM specification	46,0 x 11 x 167,3	A/S - Cr -	- 45° - -	9 - III		<b>48300</b> (1)
[50]	Ø 11 mm				468305	<b>RK-11H</b>
IN [6]	17,98 x 11 x 82,0	G2				<b>81-47117</b>
IN [6]	18,03 x 11 x 82,0	G1			422320	<b>81-47109</b>
EX [6]	18,00 x 11 x 66,0	G1			1545135 421297	<b>81-47104</b>
EX [1]	18,00 x 11 x 66,0	G1			11129092	<b>81-47124</b> <small>NEW</small>
IN [2]	54,06 x 44.35 x 6,7	G1 30°			06-0256 467474	<b>92-47011</b>
IN [2]	54,26 x 44.35 x 6,9	G1 30°			06-0405 467590	<b>92-47012</b>
EX [2]	49,09 x 40 x 9,4	G1 45°			1545886	<b>92-47015</b>
EX [2]	49,29 x 40 x 9,6	G1 45°			1545885	<b>92-47016</b>
EX [1]	49,08 x 40 x 11,4	G1 45°			06-0258 467475	<b>92-47013</b>
[12]	M 36 x 72				15455397 15455405 4223186 4790317 4798633	<b>20 1004 12001</b>
[12]	M 36 x 72				1535539	<b>20 1004 12003</b>

## 105 120,65

<b>MD 100</b>	<b>A, B</b>								
	01.1965 →	D	6	9600 cm <sup>3</sup>	2V	98-147 kW	(133-200 PS)	17:1	140,00 mm
<b>TD 100</b>	<b>HC</b>								
		D (A)	6	9600 cm <sup>3</sup>	2V	169-191 kW	(230-260 PS)	15/17:1	140,00 mm
<b>TD 101</b>	<b>GB, GE, KC, MC</b>								
		D (LA)	6	9600 cm <sup>3</sup>	2V	185-228 kW	(252-310 PS)		140,00 mm
<b>TD 102</b>	<b>FAQ, FBQ, FCQ, FEQ, FGO, FS</b>								
	10.1987 →	D (LA)	6	9600 cm <sup>3</sup>	2V	191-250 kW	(260-340 PS)	15:1	140,00 mm
<b>TD 102 Euro 1</b>	<b>FT</b>								
	01.1990 →	D (LA)	6	9600 cm <sup>3</sup>	2V	228 kW	(310 PS)	15:1	140,00 mm
<b>TD 103 Euro 1</b>	<b>KB, KF, ME</b>								
		D (LA)	6	9600 cm <sup>3</sup>	2V	210-235 kW	(286-320 PS)		140,00 mm
<b>TD 103 Euro 2</b>	<b>KAE</b>								
	08.1995 →	D (LA)	6	9600 cm <sup>3</sup>	2V	190 kW	(258 PS)	18:1	140,00 mm
<b>THD 100</b>	<b>A, EA, EE, EK</b>								
	01.1965 → 01.1996	D (A)	6	9600 cm <sup>3</sup>	2V	133-212 kW	(180-288 PS)		140,00 mm
<b>THD 101</b>	<b>KE, MC</b>								
	01.1978 →	D (LA)	6	9600 cm <sup>3</sup>	2V	228-235 kW	(310-320 PS)	15:1	140,00 mm
<b>THD 101</b>	<b>B</b>								
	1975 → 1982	D (A)	6	9600 cm <sup>3</sup>	2V	169-191 kW	(230-260 PS)	15/17:1	140,00 mm

91 359 6.., 91 360 6.., 93 660 6.., 93 734 6.., 99 750 6.., 99 751 6..

Fortsetzung nächste Seite / continued on next page / suite page suivante / continuación página próxima / Продолжение на следующей странице

					Reference	Item No.
	IN [1] 50,0 x 11 x 167,4	S - Cr -	- 30° - -	9 - III	154 52 90 467502 467502-1 4675021 479204 479205	<b>105-35037</b>
	EX [1] 46,0 x 11 x 167,2	RA/S- Cr -	- 45° - VS -	9 - III	467503 467682 467855 467855-3 4678553 8194224	<b>48151</b>
	EX [1] 46,0 x 11 x 167,3 (1) IAM specification	A/S - Cr -	- 45° - -	9 - III		<b>48300</b> (1)
	[50] Ø 11 mm				468305	<b>RK-11H</b>
	IN [6] 17,98 x 11 x 82,0	G2				<b>81-47117</b>
	IN [6] 18,03 x 11 x 82,0	G1			422320	<b>81-47109</b>
	EX [6] 18,00 x 11 x 66,0	G1			1545135 421297	<b>81-47104</b>
	EX [1] 18,00 x 11 x 66,0	G1			11129092	<b>81-47124</b> <small>NEW</small>
	IN [2] 54,06 x 44.35 x 6,7	G1 30°			06-0256 467474	<b>92-47011</b>
	IN [2] 54,26 x 44.35 x 6,9	G1 30°			06-0405 467590	<b>92-47012</b>
	IN [1] 54,10 x 44.4 x 6,7	G1 30°			422011	<b>92-47005</b>
	EX [1] 49,08 x 40 x 11,4	G1 45°			06-0258 467475	<b>92-47013</b>
	EX [1] 51,11 x 40.08 x 9,6	G1 45°			422012	<b>92-47006</b>
	[12] M 36 x 72				15455397 15455405 4223186 4790317 4798633	<b>20 1004 12001</b>
	[12] M 36 x 72				1535539	<b>20 1004 12003</b>

## 106 120,65

<b>TD 100</b>	<b>CHC, G, GA</b> 01.1973 →	D (A)	6	9600 cm <sup>3</sup>	2V	192-213 kW	(261-290 PS)	14,3:1	140,00 mm
<b>TD 101</b>	<b>GG</b> 01.1965 →	D (LA)	6	9600 cm <sup>3</sup>	2V	200 kW	(272 PS)	14,3:1	140,00 mm
<b>TD 104 Euro 2</b>	<b>KAE</b>	D (LA)	6	9600 cm <sup>3</sup>	2V	190 kW	(258 PS)	18:1	140,00 mm
<b>THD 100</b>	<b>EB, EC</b> 1982 →	D (A)	6	9600 cm <sup>3</sup>	2V	160-203 kW	(218-276 PS)	15:1	140,00 mm
<b>THD 100</b>	<b>E, ED</b> 01.1965 →	D (LA)	6	9600 cm <sup>3</sup>	2V	160-203 kW	(218-276 PS)	15:1	140,00 mm

93 660 6..., 93 734 6..., 99 750 6..

	IN [1] 50,0 x 11 x 167,4	S - Cr -	- 30° - -	9 - III	154 52 90 467502 467502-1 4675021 479204 479205	<b>105-35037</b>
	EX [1] 46,0 x 11 x 167,2	RA/S- Cr -	- 45° - VS -	9 - III	467503 467682 467855 467855-3 4678553 8194224	<b>48151</b>
	EX [1] 46,0 x 11 x 167,3	A/S - Cr -	- 45° - -	9 - III		<b>48300</b> (1)

Fortsetzung nächste Seite / continued on next page / suite page suivante / continuación página próxima / Продолжение на следующей странице

					Reference	Item No.
(1)	IAM specification					
[50]	Ø 11 mm				468305	<b>RK-11H</b>
IN [6]	17,98 x 11 x 82,0	G2			422320	<b>81-47117</b>
IN [6]	18,03 x 11 x 82,0	G1			1545135	<b>81-47109</b>
EX [6]	18,00 x 11 x 66,0	G1			421297	<b>81-47104</b>
EX [1]	18,00 x 11 x 66,0	G1			11129092	<b>81-47124</b> <small>NEW</small>
IN [2]	54,06 x 44.35 x 6,7	G1 30°			06-0256	<b>92-47011</b>
IN [2]	54,26 x 44.35 x 6,9	G1 30°			467474	<b>92-47012</b>
EX [2]	49,09 x 40 x 9,4	G1 45°			06-0405	<b>92-47015</b>
EX [2]	49,29 x 40 x 9,6	G1 45°			467590	<b>92-47016</b>
EX [1]	49,08 x 40 x 11,4	G1 45°			1545886	<b>92-47013</b>
EX [2]	49,29 x 40 x 9,6	G1 45°			1545885	<b>92-47016</b>
EX [1]	49,08 x 40 x 11,4	G1 45°			06-0258	<b>92-47013</b>
EX [1]	49,08 x 40 x 11,4	G1 45°			467475	<b>92-47013</b>
	1010 mm				15450711	<b>20 1004 10200</b>
					479450	
					479610	
					4796108	
					8194480	
[12]	M 36 x 72				15455397	<b>20 1004 12001</b>
					15455405	
					4223186	
					4790317	
					4798633	
[12]	M 36 x 72				1535539	<b>20 1004 12003</b>
<b>107</b>	<b>120,65</b>					
<b>D 100</b>	<b>A, B</b>					
91 360 6..	08.1965 →	D (NA)	6	9600 cm <sup>3</sup>	2V 122-147 kW (166-200 PS) 17:1	140,00 mm
IN [6]	17,98 x 11 x 82,0	G2				<b>81-47117</b>
IN [6]	18,03 x 11 x 82,0	G1			422320	<b>81-47109</b>
EX [6]	18,00 x 11 x 66,0	G1			1545135	<b>81-47104</b>
					421297	
EX [1]	18,00 x 11 x 66,0	G1			11129092	<b>81-47124</b> <small>NEW</small>
IN [2]	54,06 x 44.35 x 6,7	G1 30°			06-0256	<b>92-47011</b>
IN [2]	54,26 x 44.35 x 6,9	G1 30°			467474	<b>92-47012</b>
EX [1]	49,08 x 40 x 11,4	G1 45°			06-0405	<b>92-47015</b>
					467590	<b>92-47016</b>
					06-0258	<b>92-47013</b>
					467475	<b>92-47013</b>
[12]	M 36 x 72				15455397	<b>20 1004 12001</b>
					15455405	
					4223186	
					4790317	
					4798633	
[12]	M 36 x 72				1535539	<b>20 1004 12003</b>
<b>108</b>	<b>120,65</b>					
<b>TD 100</b>	<b>A, C</b>					
	08.1965 → 12.1989	D (A)	6	9600 cm <sup>3</sup>	2V 176-190 kW (239-258 PS)	140,00 mm
<b>THD 100</b>	<b>DA, DB, DC</b>					
	06.1978 →	D (LA)	6	9600 cm <sup>3</sup>	2V 133-203 kW (181-276 PS) 15:1	140,00 mm
<b>THD 100</b>	<b>D, DD</b>					
	04.1966 →	D (A)	6	9600 cm <sup>3</sup>	2V 155-203 kW (211-276 PS) 15:1	140,00 mm
91 359 6.., 93 660 6..						
Fortsetzung nächste Seite / continued on next page / suite page suivante / continuación página próxima / Продолжение на следующей странице						

					Reference	Item No.
	IN [1] 50,0 x 11 x 167,4	S - Cr -	- 30° - -	9 - III	154 52 90 467502 467502-1 4675021 479204 479205	<b>105-35037</b>
	EX [1] 46,0 x 11 x 167,2	RA/S- Cr -	- 45° - VS -	9 - III	467503 467682 467855 467855-3 4678553 8194224	<b>48151</b>
	EX [1] 46,0 x 11 x 167,3 (1) IAM specification	A/S - Cr -	- 45° - -	9 - III		<b>48300</b> (1)
	[50] Ø 11 mm				468305	<b>RK-11H</b>
	IN [6] 17,98 x 11 x 82,0 IN [6] 18,03 x 11 x 82,0 EX [6] 18,00 x 11 x 66,0	G2 G1 G1			422320 1545135 421297 11129092	<b>81-47117</b> <b>81-47109</b> <b>81-47104</b>
	EX [1] 18,00 x 11 x 66,0	G1				<b>81-47124</b>
	IN [2] 54,06 x 44.35 x 6,7 IN [2] 54,26 x 44.35 x 6,9	G1 30° G1 30°			06-0256 467474 06-0405 467590	<b>92-47011</b> <b>92-47012</b>
	EX [2] 49,09 x 40 x 9,4 EX [2] 49,29 x 40 x 9,6 EX [1] 49,08 x 40 x 11,4	G1 45° G1 45° G1 45°			1545886 1545885 06-0258 467475	<b>92-47015</b> <b>92-47016</b> <b>92-47013</b>
	1012 mm - 9,2 mm				4223632 4678538	<b>20 1004 10000</b>
	[12] M 36 x 72				15455397 15455405 4223186 4790317 4798633 1535539	<b>20 1004 12001</b>
	[12] M 36 x 72					<b>20 1004 12003</b>

## 109 120,65

<b>D 10 Euro 2</b>	<b>A 245, A 310, A 350, C 320, C 360</b>							
	12.1995 →	D (LA)	6	9600 cm <sup>3</sup>	2V	180-265 kW	(245-360 PS)	140,00 mm
<b>D10A320 Euro 2</b>	01.1990 →	D (A)	6	9600 cm <sup>3</sup>	2V	235 kW	(320 PS) 20:1	140,00 mm
<b>D10A360 Euro 2</b>	02.1995 → 09.1998	D (A)	6	9600 cm <sup>3</sup>	2V	265 kW	(360 PS) 20:1	140,00 mm
<b>D10B320 Euro 2</b>	04.1999 → 09.2003	D (LA)	6	9600 cm <sup>3</sup>	2V	235 kW	(320 PS) 20:1	140,00 mm
<b>D10B360 Euro 2</b>	04.1999 → 08.2011	D (LA)	6	9600 cm <sup>3</sup>	2V	265 kW	(360 PS) 19,5:1	140,00 mm
<b>DH 10 Euro 2</b>	<b>A 340, A 350</b>							
	01.1995 → 12.2003	D (LA)	6	9600 cm <sup>3</sup>	2V	250-257 kW	(340-350 PS) 20:1	140,00 mm
<b>DH10A245 Euro 2</b>	01.1985 →	D (LA)	6	9600 cm <sup>3</sup>	2V	180 kW	(245 PS) 20:1	140,00 mm
<b>DH10A285 Euro 2</b>	01.1988 → 12.2003	D (LA)	6	9600 cm <sup>3</sup>	2V	210 kW	(285 PS) 20:1	140,00 mm
<b>DH10A360 Euro 2</b>	01.1992 → 08.2011	D (LA)	6	9600 cm <sup>3</sup>	2V	265 kW	(360 PS) 18-20:1	140,00 mm
<b>THD 102</b>	<b>KA, KE, KF, KJ</b>							
	01.1978 →	D (LA)	6	9600 cm <sup>3</sup>	2V	158-235 kW	(215-320 PS) 16:1	140,00 mm
<b>THD 103 Euro 2</b>	<b>E, ES</b>							
		D (LA)	6	9600 cm <sup>3</sup>	2V	235 kW	(320 PS) 18:1	140,00 mm

Fortsetzung nächste Seite / continued on next page / suite page suivante / continuación página próxima / Продолжение на следующей странице

					Reference	Item No.
<b>THD 103 Euro 1</b>						
<b>KB, KD, KF</b>						
01.1985 → 12.2003 D (A) 6 9600 cm <sup>3</sup> 2V 180-250 kW (245-340 PS) 140,00 mm						
40 050 6.., 40 051 6.., 99 453 6.., 99 751 6..						
	IN [1]	50,0 x 11 x 167,4	S - Cr -	- 30° - -	9 - III	479261 8194223 <b>48324</b>
	EX [1]	46,0 x 11 x 167,2	RA/S- Cr -	- 45° - VS -	9 - III	467503 467682 467855 467855-3 4678553 8194224 <b>48151</b>
	EX [1] (1) IAM specification	46,0 x 11 x 167,3	A/S - Cr -	- 45° - -	9 - III	<b>48300</b> (1)
	[50]	∅ 11 mm				468305 <b>RK-11H</b>
	IN [6]	17,98 x 11 x 82,0	G2			<b>81-47117</b>
	IN [6]	18,03 x 11 x 82,0	G1		422320	<b>81-47109</b>
	EX [6]	18,00 x 11 x 66,0	G1		1545135 421297	<b>81-47104</b>
	EX [1]	18,00 x 11 x 66,0	G1		11129092	<b>81-47124</b> <small>NEW</small>
	IN [2]	54,06 x 44.35 x 6,7	G1 30°		06-0256 467474	<b>92-47011</b>
	IN [2]	54,26 x 44.35 x 6,9	G1 30°		06-0405 467590	<b>92-47012</b>
	EX [2]	49,09 x 40 x 9,4	G1 45°		1545886	<b>92-47015</b>
	EX [2]	49,29 x 40 x 9,6	G1 45°		1545885	<b>92-47016</b>
	EX [1]	49,08 x 40 x 11,4	G1 45°		06-0258 467475	<b>92-47013</b>
	[12]	M 36 x 72			15455397 15455405 4223186 4790317 4798633	<b>20 1004 12001</b>
	[12]	M 36 x 72			1535539	<b>20 1004 12003</b>
<b>110</b> <b>120,65</b>						
<b>TMD 102</b>						
<b>A, C</b>						
1988 → 2000 D (LA) 6 9600 cm <sup>3</sup> 2V 104-200 kW (141-272 PS) 14,3:1 140,00 mm						
93 734 6..						
	IN [6]	17,98 x 11 x 82,0	G2			<b>81-47117</b>
	IN [6]	18,03 x 11 x 82,0	G1		422320	<b>81-47109</b>
	EX [6]	18,00 x 11 x 66,0	G1		1545135 421297	<b>81-47104</b>
	EX [1]	18,00 x 11 x 66,0	G1		11129092	<b>81-47124</b> <small>NEW</small>
	IN [2]	54,06 x 44.35 x 6,7	G1 30°		06-0256 467474	<b>92-47011</b>
	IN [2]	54,26 x 44.35 x 6,9	G1 30°		06-0405 467590	<b>92-47012</b>
	EX [2]	49,09 x 40 x 9,4	G1 45°		1545886	<b>92-47015</b>
	EX [2]	49,29 x 40 x 9,6	G1 45°		1545885	<b>92-47016</b>
	[12]	M 36 x 72			15455397 15455405 4223186 4790317 4798633	<b>20 1004 12001</b>
	[12]	M 36 x 72			1535539	<b>20 1004 12003</b>



					Reference	Item No.	
<b>111</b>		<b>120,65</b>					
<b>THD 102 Euro 1</b>	<b>KB</b>						
	01.1988 → 12.2003	D (LA)	6	9600 cm <sup>3</sup>	2V	210 kW (286 PS) 16:1 140,00 mm	
<b>THD 102</b>	<b>KD</b>						
	01.1988 → 12.2003	D (LA)	6	9600 cm <sup>3</sup>	2V	252 kW (343 PS) 16:1 140,00 mm	
99 453 6..							
	IN [1]	50,0 x 11 x 167,4	S - Cr -	- 30° -	- 9 - III	479261 8194223	<b>48324</b>
	EX [1]	46,0 x 11 x 167,2	RA/S- Cr -	- 45° - VS -	9 - III	467503 467682 467855 467855-3 4678553 8194224	<b>48151</b>
	EX [1]	46,0 x 11 x 167,3 (1) IAM specification	A/S - Cr -	- 45° -	9 - III		<b>48300</b> (1)
	[50]	∅ 11 mm				468305	<b>RK-11H</b>
	IN [6]	18,00 x 11.04 x 72,0	G2			422762	<b>81-47116</b>
	EX [6]	18,00 x 11 x 66,0	G1			1545135 421297	<b>81-47104</b>
	EX [1]	18,00 x 11 x 66,0	G1			11129092	<b>81-47124</b> <small>NEW</small>
	IN [2]	54,06 x 44.35 x 6,7	G1 30°			06-0256 467474	<b>92-47011</b>
	IN [2]	54,26 x 44.35 x 6,9	G1 30°			06-0405 467590	<b>92-47012</b>
	EX [2]	49,09 x 40 x 9,4	G1 45°			1545886	<b>92-47015</b>
	EX [2]	49,29 x 40 x 9,6	G1 45°			1545885	<b>92-47016</b>
	EX [1]	49,08 x 40 x 11,4	G1 45°			06-0258 467475	<b>92-47013</b>
		1010 mm				15450711 479450 479610 4796108 8194480	<b>20 1004 10200</b>
	[12]	M 36 x 72				15455397 15455405 4223186 4790317 4798633	<b>20 1004 12001</b>
	[12]	M 36 x 72				1535539	<b>20 1004 12003</b>
<b>112</b>		<b>120,65</b>					
<b>TAMD 102</b>	<b>A, D</b>						
	1991 → 2000	D (LA)	6	9600 cm <sup>3</sup>	2V	235-346 kW (320-470 PS) 14,3:1 140,00 mm	
<b>TAMD 103</b>	<b>A-A</b>						
	2000 → 2004	D (LA)	6	9600 cm <sup>3</sup>	2V	199-287 kW (270-390 PS) 17:1 140,00 mm	
	IN [6]	18,00 x 11.04 x 72,0	G2			422762	<b>81-47116</b>
	EX [6]	18,00 x 11 x 66,0	G1			1545135 421297	<b>81-47104</b>
	EX [1]	18,00 x 11 x 66,0	G1			11129092	<b>81-47124</b> <small>NEW</small>
	IN [2]	54,06 x 44.35 x 6,7	G1 30°			06-0256 467474	<b>92-47011</b>
	IN [2]	54,26 x 44.35 x 6,9	G1 30°			06-0405 467590	<b>92-47012</b>
	EX [2]	49,09 x 40 x 9,4	G1 45°			1545886	<b>92-47015</b>
	EX [2]	49,29 x 40 x 9,6	G1 45°			1545885	<b>92-47016</b>

V

					Reference	Item No.	
<b>113</b>		<b>123</b>					
<b>D11A-370 Euro 3</b>	09.2005 →	D (LA) 6	10837 cm <sup>3</sup> 4V	272 kW	(370 PS) 18,3:1	152,00 mm	
<b>D11A430 Euro 3</b>	04.2010 →	D (LA) 6	10837 cm <sup>3</sup> 4V	317 kW	(431 PS) 18,3:1	152,00 mm	
	IN [2]	40,0 x 8 x 192,0	RA/S- Cr -	- 30° - VS -	22 - III	20540012 20540013 20540017 20737856 21427620	<b>48313</b>
	EX [2]	38,0 x 8 x 192,7	RA/S- Cr -	- 30° - VS -	22 - III	20464020 20564019 20564020 21430918 22686466 3842972	<b>48314</b>
	[50]	Ø 8 mm				20510747 419643	<b>MK-8H</b>
	IN/EX [6]	15,00 x 8.01 x 83,4	G2			1546437 20817645 20817648 20904074 20905400 20919484 3165303 3183283	<b>81-47119</b>
	IN/EX [6]	15,00 x 8.02 x 83,2	G2			1546437 20817645 20817648 20904074 20905400 20919484 3165303 3183283	<b>81-47114</b>
	IN [1]	42,00 x 33 x 7,3	G3 30°			20509465	<b>92-47030</b>
	EX [1]	40,00 x 31.2 x 6,4	G3 30°			20732758	<b>92-47031</b>
						20746808 22431874 22584594 20746807 22431873 22584593 21189194 22431872 22584592	<b>20 1004 11000</b> (1)  <b>20 1004 11001</b> (2)  <b>20 1004 11002</b> (3)
	(1)	EBR-VEB (Motorbremsentyp - Volvo Motorbremse einschließlich Auspuffdrucklager) EBR-EPGC (Motorbremsentyp - Auspuffdruckregler mit VCB (Volvo Kompressionsbremse)) EBR-VEB - (engine brake type - Volvo engine brake including exhaust thrust bearing) EPGC - (engine brake type - integrated pressure regulator with VCB (Volvo compression brake)) EBR-VEB - (type de frein moteur - frein moteur Volvo avec butée d'embrayage) EPGC - (type de frein moteur - butée d'embrayage avec VCB (frein par compression Volvo)) EBR-VEB - (tipo de freno del motor: freno del motor Volvo incluido cojinete de empuje de gases de escape) EPGC - (tipo de freno del motor: regulador de empuje de gases de escape con VCB (freno de compresión Volvo)) EBR-VEB (Тип моторного тормоза — моторный тормоз Volvo вместе с упорным подшипником системы выпуска) EPGC - (Тип моторного тормоза — регулятор давления системы выпуска с VCB (компрессионный тормоз Volvo))					
	(2)	EBR-EPG Motorbremsentyp - Auspuffdrucklager/engine brake type - exhaust thrust bearing/type de frein moteur - butée d'embrayage/tipo de freno del motor: cojinete de empuje de gases de escape/ Тип моторного тормоза — упорный подшипник системы выпуска					
	(3)	Volvo information: EBR-VEB/EBR-EPGC,EM-EC06/EM-EU5					

					Reference	Item No.	
<b>114</b>		<b>123</b>					
<b>D11C330 Euro 5</b>	09.2005 →	D (LA) 6	10837 cm <sup>3</sup> 4V	243 kW	(330 PS)	17,1:1 152,00 mm	
<b>D11C370 Euro 5</b>	09.2005 →	D (LA) 6	10837 cm <sup>3</sup> 4V	272 kW	(370 PS)	17,3-18, 152,00 mm	
<b>D11C410 Euro 5</b>	09.2005 →	D (LA) 6	10837 cm <sup>3</sup> 4V	302 kW	(410 PS)	17,3-18, 152,00 mm	
<b>D11C450 Euro 5</b>	09.2005 →	D (LA) 6	10837 cm <sup>3</sup> 4V	332 kW	(450 PS)	17,1:1 152,00 mm	
<b>D11K380 Euro 6</b>	09.2013 →	D (LA) 6	10837 cm <sup>3</sup> 4V	280 kW	(380 PS)	17,1:1 152,00 mm	
<b>D11K430 Euro 6</b>	09.2013 →	D (LA) 6	10837 cm <sup>3</sup> 4V	316 kW	(430 PS)	17,1:1 152,00 mm	
<b>D11K460 Euro 6</b>	09.2013 →	D (LA) 6	10837 cm <sup>3</sup> 4V	338 kW	(460 PS)	17,1:1 152,00 mm	
	IN [2]	40,0 x 8 x 192,0	RA/S- Cr -	- 30° - VS -	22 - III	20540012 20540013 20540017 20737856 21427620	<b>48313</b>
	EX [2]	38,0 x 8 x 192,7	RA/S- Cr -	- 30° - VS -	22 - III	20464020 20564019 20564020 21430918 22686466 3842972	<b>48314</b>
	[50]	Ø 8 mm				20510747 419643	<b>MK-8H</b>
	IN/EX [6]	15,00 x 8.01 x 83,4	G2			1546437 20817645 20817648 20904074 20905400 20919484 3165303 3183283	<b>81-47119</b>
	IN/EX [6]	15,00 x 8.02 x 83,2	G2			1546437 20817645 20817648 20904074 20905400 20919484 3165303 3183283	<b>81-47114</b>
	IN [1]	42,00 x 33 x 7,3	G3 30°			20509465	<b>92-47030</b>
	EX [1]	40,00 x 31.2 x 6,4	G3 30°			20732758	<b>92-47031</b>
						20746808 22431874 22584594 20746807 22431873 22584593	<b>20 1004 11000</b> (1) <b>20 1004 11001</b> (2)
	<p>(1) EBR-VEB (Motorbremsentyp - Volvo Motorbremse einschließlich Auspuffdrucklager)            EBR-EPGC (Motorbremsentyp - Auspuffdruckregler mit VCB (Volvo Kompressionsbremse))            EBR-VEB - (engine brake type - Volvo engine brake including exhaust thrust bearing)            EPGC - (engine brake type - integrated pressure regulator with VCB (Volvo compression brake))            EBR-VEB - (type de frein moteur - frein moteur Volvo avec butée d'embrayage)            EPGC - (type de frein moteur - butée d'embrayage avec VCB (frein par compression Volvo))            EBR-VEB - (tipo de freno del motor: freno del motor Volvo incluido cojinete de empuje de gases de escape)            EPGC - (tipo de freno del motor: regulador de empuje de gases de escape con VCB (freno de compresión Volvo))            EBR-VEB (Тип моторного тормоза — моторный тормоз Volvo вместе с упорным подшипником системы выпуска)            EPGC - (Тип моторного тормоза — регулятор давления системы выпуска с VCB (компрессионный тормоз Volvo))</p>						
Fortsetzung nächste Seite / continued on next page / suite page suivante / continuación página próxima / Продолжение на следующей странице							

V

					Reference	Item No.	
(2)	EBR-EPG Motorbremsentyp - Auspuffdrucklager/engine brake type - exhaust thrust bearing/type de frein moteur - butée d'embrayage/tipo de freno del motor: cojinete de empuje de gases de escape/ Тип моторного тормоза — упорный подшипник системы выпуска						
<b>115</b>		<b>123</b>					
<b>D11K330 Euro 6</b>	09.2005 →	D (LA) 6	10837 cm <sup>3</sup>	4V	243 kW (330 PS)	17,1:1 152,00 mm	
<b>D11K370 Euro 6</b>	09.2005 →	D (LA) 6	10837 cm <sup>3</sup>	4V	272 kW (370 PS)	17,1:1 152,00 mm	
<b>D11K410 Euro 6</b>	09.2005 →	D (LA) 6	10837 cm <sup>3</sup>	4V	302 kW (410 PS)	17,1:1 152,00 mm	
<b>D11K450 Euro 6</b>	09.2005 →	D (LA) 6	10837 cm <sup>3</sup>	4V	332 kW (450 PS)	17,1:1 152,00 mm	
	IN [2]	40,0 x 8 x 192,0	RA/S- Cr -	- 30° - VS -	22 - III	20540012 20540013 20540017 20737856 21427620	<b>48313</b>
	EX [2]	38,0 x 8 x 192,7	RA/S- Cr -	- 30° - VS -	22 - III	20464020 20564019 20564020 21430918 22686466 3842972	<b>48314</b>
	[50]	Ø 8 mm				20510747 419643	<b>MK-8H</b>
	IN/EX [6]	15,00 x 8.01 x 83,4	G2			1546437 20817645 20817648 20904074 20905400 20919484 3165303 3183283	<b>81-47119</b>
	IN/EX [6]	15,00 x 8.02 x 83,2	G2			1546437 20817645 20817648 20904074 20905400 20919484 3165303 3183283	<b>81-47114</b>
	IN [1]	42,00 x 33 x 7,3	G3 30°			20509465	<b>92-47030</b> <small>NEW</small>
	EX [1]	40,00 x 31.2 x 6,4	G3 30°			20732758	<b>92-47031</b> <small>NEW</small>
						20746808 22431874 22584594 20746807 22431873 22584593 21745877 23289200	<b>20 1004 11000</b> (1) <b>20 1004 11001</b> (2) <b>20 1004 11003</b> (3)
(1)	EBR-VEB (Motorbremsentyp - Volvo Motorbremse einschließlich Auspuffdrucklager) EBR-EPGC (Motorbremsentyp - Auspuffdruckregler mit VCB (Volvo Kompressionsbremse) EBR-VEB - (engine brake type - Volvo engine brake including exhaust thrust bearing) EPGC - (engine brake type - integrated pressure regulator with VCB (Volvo compression brake) EBR-VEB - (type de frein moteur - frein moteur Volvo avec butée d'embrayage) EPGC - (type de frein moteur - butée d'embrayage avec VCB (frein par compression Volvo)) EBR-VEB - (tipo de freno del motor: freno del motor Volvo incluido cojinete de empuje de gases de escape) EPGC - (tipo de freno del motor: regulador de empuje de gases de escape con VCB (freno de compresión Volvo) EBR-VEB (Тип моторного тормоза — моторный тормоз Volvo вместе с упорным подшипником системы выпуска) EPGC - (Тип моторного тормоза — регулятор давления системы выпуска с VCB (компрессионный тормоз Volvo)						

Fortsetzung nächste Seite / continued on next page / suite page suivante / continuación página próxima / Продолжение на следующей странице

					Reference	Item No.
(2)	EBR-EPG Motorbremsentyp - Auspuffdrucklager/engine brake type - exhaust thrust bearing/type de frein moteur - butée d'embrayage/tipo de freno del motor: cojinete de empuje de gases de escape/ Тип моторного тормоза — упорный подшипник системы выпуска					
(3)	Volvo information: EBR-VEB/EBR-EPGC,EM-EC06/EM-EU5					

**116**
**123**

<b>D 11</b>	<b>A-A, A-B</b>							
	2007 →	D (LA)	6	10800 cm <sup>3</sup>	4V	493 kW	(670 PS)	16,5:1 152,00 mm
<b>D 11</b>	<b>A-C, A-C MP, A-D (IPS), A-D MP, A-E</b>							
		D (A)	6	10800 cm <sup>3</sup>	4V			16,5:1 152,00 mm

	IN [2]	40,0 x 8 x 192,0	RA/S- Cr -	- 30° - VS -	22 - III	20540012 20540013 20540017 20737856 21427620	<b>48313</b>
	EX [2]	38,0 x 8 x 192,7	RA/S- Cr -	- 30° - VS -	22 - III	20464020 20564019 20564020 21430918 22686466 3842972	<b>48314</b>
	[50]	∅ 8 mm				20510747 419643	<b>MK-8H</b>
	IN/EX [6]	15,00 x 8.01 x 83,4	G2			1546437 20817645 20817648 20904074 20905400 20919484 3165303 3183283	<b>81-47119</b>
	IN/EX [6]	15,00 x 8.02 x 83,2	G2			1546437 20817645 20817648 20904074 20905400 20919484 3165303 3183283	<b>81-47114</b>
	IN [1] EX [1]	42,00 x 33 x 7,3 40,00 x 31.2 x 6,4	G3 30° G3 30°			20509465 20732758	<b>92-47030</b> <b>92-47031</b>
						20451775	<b>20 1004 09000</b> (1)
	(1) EBR-EPG Motorbremsentyp - Auspuffdrucklager/engine brake type - exhaust thrust bearing/type de frein moteur - butée d'embrayage/tipo de freno del motor: cojinete de empuje de gases de escape/ Тип моторного тормоза — упорный подшипник системы выпуска						

**117**
**123**

<b>D11-325</b>	08.2016 →	D (LA)	6	10837 cm <sup>3</sup>	4V	239 kW	(325 PS)	17:1 152,00 mm
<b>D11-355</b>	08.2016 →	D (LA)	6	10837 cm <sup>3</sup>	4V	261 kW	(355 PS)	17:1 152,00 mm
<b>D11-365</b>	08.2016 →	D (LA)	6	10837 cm <sup>3</sup>	4V	268 kW	(365 PS)	17:1 152,00 mm
<b>D11-385</b>	08.2016 →	D (LA)	6	10837 cm <sup>3</sup>	4V	283 kW	(385 PS)	17:1 152,00 mm
<b>D11-425</b>		D (LA)	6	10800 cm <sup>3</sup>	4V	312 kW	(425 PS)	17:1 152,00 mm

						20746808 22431874 22584594 20746807 22431873 22584593	<b>20 1004 11000</b> (1) <b>20 1004 11001</b> (2)
--	--	--	--	--	--	--	--

Fortsetzung nächste Seite / continued on next page / suite page suivante / continuación página próxima / Продолжение на следующей странице

					Reference	Item No.
(1)	EBR-VEB (Motorbremsentyp - Volvo Motorbremse einschließlich Auspuffdrucklager) EBR-EPGC (Motorbremsentyp - Auspuffdruckregler mit VCB (Volvo Kompressionsbremse) EBR-VEB - (engine brake type - Volvo engine brake including exhaust thrust bearing EPGC - (engine brake type - integrated pressure regulator with VCB (Volvo compression brake) EBR-VEB - (type de frein moteur - frein moteur Volvo avec butée d'embrayage) EPGC - (type de frein moteur - butée d'embrayage avec VCB (frein par compression Volvo)) EBR-VEB - (tipo de freno del motor: freno del motor Volvo incluido cojinete de empuje de gases de escape) EPGC - (tipo de freno del motor: regulador de empuje de gases de escape con VCB (freno de compresión Volvo) EBR-VEB (Тип моторного тормоза — моторный тормоз Volvo вместе с упорным подшипником системы выпуска) EPGC - (Тип моторного тормоза — регулятор давления системы выпуска с VCB (компрессионный тормоз Volvo)					
(2)	EBR-EPG Motorbremsentyp - Auspuffdrucklager/engine brake type - exhaust thrust bearing/type de frein moteur - butée d'embrayage/tipo de freno del motor: cojinete de empuje de gases de escape/Тип моторного тормоза — упорный подшипник системы выпуска					

**118**

123

D 11	A-C (IPS), A-E MP		D (A)	6	10800 cm <sup>3</sup>	4V	16,5:1	152,00 mm
	IN/EX [6]	15,00 x 8.01 x 83,4	G2					
								1546437 20817645 20817648 20904074 20905400 20919484 3165303 3183283
								81-47119
	IN/EX [6]	15,00 x 8.02 x 83,2	G2					
								1546437 20817645 20817648 20904074 20905400 20919484 3165303 3183283
								81-47114
	IN [1]	42,00 x 33 x 7,3	G3 30°					20509465
	EX [1]	40,00 x 31.2 x 6,4	G3 30°					20732758
								92-47030 <b>NEW</b> 92-47031 <b>NEW</b>

**119**

123

D11B1-A MP	D (A)		6	10840 cm <sup>3</sup>	4V	493-533 kW (670-725 PS)	16,5:1	152,00 mm
D11B2-A MP	D (A)		6	10840 cm <sup>3</sup>	4V	493-533 kW (670-725 PS)	16,5:1	152,00 mm
D11B3-A MP	D (A)		6	10840 cm <sup>3</sup>	4V		16,5:1	152,00 mm
D11B4-A MP	D (A)		6	10840 cm <sup>3</sup>	4V		16,5:1	152,00 mm
	IN/EX [6]	15,00 x 8.01 x 83,4	G2					
								1546437 20817645 20817648 20904074 20905400 20919484 3165303 3183283
								81-47119
	IN/EX [6]	15,00 x 8.02 x 83,2	G2					
								1546437 20817645 20817648 20904074 20905400 20919484 3165303 3183283
								81-47114
	IN [1]	42,00 x 33 x 7,3	G3 30°					20509465
	EX [1]	40,00 x 31.2 x 6,4	G3 30°					20732758
								92-47030 <b>NEW</b> 92-47031 <b>NEW</b>

Fortsetzung nächste Seite / continued on next page / suite page suivante / continuación página próxima / Продолжение на следующей странице



					Reference	Item No.
					20451775	20 1004 09000 (1)
(1) EBR-EPG Motorbremsentyp - Auspuffdrucklager/engine brake type - exhaust thrust bearing/type de frein moteur - butée d'embrayage/tipo de freno del motor: cojinete de empuje de gases de escape/ Тип моторного тормоза — упорный подшипник системы выпуска						

<b>120</b>		<b>123</b>						
TAD1140VE Euro 2	D (LA) 6	10837 cm <sup>3</sup>	4V	235 kW	(320 PS)	17:1	152,00 mm	
TAD1141VE Euro 2	D (LA) 6	10837 cm <sup>3</sup>	4V	265 kW	(360 PS)	17:1	152,00 mm	
TAD1142VE Euro 2	D (LA) 6	10837 cm <sup>3</sup>	4V	285 kW	(387 PS)	17:1	152,00 mm	
TAD1150VE Euro 3	D (LA) 6	10837 cm <sup>3</sup>	4V	235 kW	(320 PS)	17:1	152,00 mm	
TAD1151VE Euro 3	D (LA) 6	10837 cm <sup>3</sup>	4V	265 kW	(360 PS)	17:1	152,00 mm	
TAD1152VE Euro 3	D (LA) 6	10837 cm <sup>3</sup>	4V	285 kW	(387 PS)	17:1	152,00 mm	
TAD1170VE Euro 4	D (LA) 6	10837 cm <sup>3</sup>	4V	235 kW	(320 PS)	17:1	152,00 mm	
TAD1171VE Euro 4	D (LA) 6	10837 cm <sup>3</sup>	4V	265 kW	(360 PS)	17:1	152,00 mm	
TAD1172VE Euro 4	D (LA) 6	10837 cm <sup>3</sup>	4V	285 kW	(387 PS)	17:1	152,00 mm	
	IN [2]	40,0 x 8 x 192,0	RA/S- Cr -	- 30° - VS -	22 - III	20540012 20540013 20540017 20737856 21427620	48313	
	EX [2]	38,0 x 8 x 192,7	RA/S- Cr -	- 30° - VS -	22 - III	20464020 20564019 20564020 21430918 22686466 3842972	48314	
	[50]	Ø 8 mm				20510747 419643	MK-8H	
	IN/EX [6]	15,00 x 8.01 x 83,4	G2			1546437 20817645 20817648 20904074 20905400 20919484 3165303 3183283	81-47119	
	IN/EX [6]	15,00 x 8.02 x 83,2	G2			1546437 20817645 20817648 20904074 20905400 20919484 3165303 3183283	81-47114	
	IN [1] EX [1]	42,00 x 33 x 7,3 40,00 x 31.2 x 6,4	G3 30° G3 30°			20509465 20732758	92-47030 92-47031	

<b>121</b>		<b>130</b>						
TD 122	F	D (A) 6	11980 cm <sup>3</sup>	2V	257-262 kW	(350-356 PS)	15:1	150,00 mm
90 081 6..								
	IN [1] EX [1]	54,0 x 11 x 167,3 50,0 x 11 x 167,3	S - Cr - A/S - Cr -	- 30° - - 45° - VS -	- - 9 - III	468302 468302-5 460803 460803-3 468303 468303-3	105-34949 48303	
	[50]	Ø 11 mm				468305	RK-11H	

Fortsetzung nächste Seite / continued on next page / suite page suivante / continuación página próxima / Продолжение на следующей странице

					Reference	Item No.
	IN [6]	17,98 x 11 x 82,0	G2			<b>81-47117</b>
	IN [6]	18,03 x 11 x 82,0	G1		422320	<b>81-47109</b>
	EX [6]	18,00 x 11 x 66,0	G1		1545135 421297	<b>81-47104</b>
	EX [1]	18,00 x 11 x 66,0	G1		11129092	<b>81-47124</b> <small>NEW</small>
	IN [2]	59,12 x 49 x 6,8	G1 30°		423011	<b>92-47007</b>
	EX [2]	56,60 x 44.95 x 9,4	G1 45°		468448	<b>92-47009</b>
	EX [2]	58,30 x 49 x 6,8	G1 45°		423208	<b>92-47008</b> <small>NEW</small>
		1072 mm			4687232 478750 4796207 81937278	<b>20 1004 12200</b>
	[12]	M 36 x 72			15455397 15455405 4223186 4790317 4798633	<b>20 1004 12001</b>
	[12]	M 36 x 72			1535539	<b>20 1004 12003</b>

## 122

## 130,17

<b>TD 121</b>	<b>G, GD</b>	08.1977 → 09.2001	D (A)	6	11980 cm <sup>3</sup>	2V	235-243 kW	(320-330 PS)	14,2:1	150,00 mm
<b>TD 121</b>	<b>F</b>	10.1979 → 09.2001	D (LA)	6	11980 cm <sup>3</sup>	2V	272-283 kW	(370-385 PS)	14,2:1	150,00 mm
<b>TD 122</b>	<b>FS</b>	01.1987 →	D (LA)	6	11980 cm <sup>3</sup>	2V	287-291 kW	(395-396 PS)	15:1	150,00 mm

41 221 6..., 41 227 6..., 90 924 6..., 93 369 7..

	IN [1]	54,0 x 11 x 167,3	S - Cr -	- 30° -	-	9 - III	468302 468302-5	<b>105-34949</b>
	EX [1]	50,0 x 11 x 167,3	A/S - Cr -	- 45° -	VS -	9 - III	460803 460803-3 468303 468303-3	<b>48303</b>
	[50]	Ø 11 mm					468305	<b>RK-11H</b>
	IN [6]	17,98 x 11 x 82,0	G2					<b>81-47117</b>
	IN [6]	18,03 x 11 x 82,0	G1				422320	<b>81-47109</b>
	EX [6]	18,00 x 11 x 66,0	G1				1545135 421297	<b>81-47104</b>
	EX [1]	18,00 x 11 x 66,0	G1				11129092	<b>81-47124</b> <small>NEW</small>
	IN [2]	59,12 x 49 x 6,8	G1 30°				423011	<b>92-47007</b>
	EX [2]	56,60 x 44.95 x 9,4	G1 45°				468448	<b>92-47009</b>
	EX [2]	58,30 x 49 x 6,8	G1 45°				423208	<b>92-47008</b> <small>NEW</small>
		1072 mm				4687232 478750 4796207 81937278	<b>20 1004 12200</b>	
	[12]	M 36 x 72					15455397 15455405 4223186 4790317 4798633	<b>20 1004 12001</b>
	[12]	M 36 x 72					1535539	<b>20 1004 12003</b>

## 123

## 130,17

<b>TWD 1210</b>	<b>V</b>		D (LA)	6	12000 cm <sup>3</sup>	2V		13,3:1	150,00 mm
-----------------	----------	--	--------	---	-----------------------	----	--	--------	-----------

99 966 6..

Fortsetzung nächste Seite / continued on next page / suite page suivante / continuación página próxima / Продолжение на следующей странице

					Reference	Item No.	
	IN [1]	54,0 x 11 x 167,3	S - Cr -	- 30° - -	9 - III	468302 468302-5	<b>105-34949</b>
	EX [1]	50,0 x 11 x 167,3	A/S - Cr -	- 45° - VS -	9 - III	460803 460803-3 468303 468303-3	<b>48303</b>
	IN/EX [6]	15,00 x 8.01 x 83,4	G2			1546437 20817645 20817648 20904074 20905400 20919484 3165303 3183283	<b>81-47119</b>
	IN/EX [6]	15,00 x 8.02 x 83,2	G2			1546437 20817645 20817648 20904074 20905400 20919484 3165303 3183283	<b>81-47114</b>
	IN [2]	59,12 x 49 x 6,8	G1 30°			423011	<b>92-47007</b>
	EX [2]	56,60 x 44.95 x 9,4	G1 45°			468448	<b>92-47009</b>
	EX [2]	58,30 x 49 x 6,8	G1 45°			423208	<b>92-47008</b> <small>NEW</small>
<b>124</b>		<b>130,175</b>					
<b>D 120</b>	1970 → 12.1981	D	6	12000 cm <sup>3</sup>	2V	177 kW (240 PS) 17:1	150,00 mm
	IN [1]	54,0 x 11 x 167,3	S - Cr -	- 30° - -	9 - III	468302 468302-5	<b>105-34949</b>
	EX [1]	50,0 x 11 x 167,3	A/S - Cr -	- 45° - VS -	9 - III	460803 460803-3 468303 468303-3	<b>48303</b>
	[50]	Ø 11 mm				468305	<b>RK-11H</b>
	IN [6]	17,98 x 11 x 82,0	G2				<b>81-47117</b>
	IN [6]	18,03 x 11 x 82,0	G1			422320	<b>81-47109</b>
	EX [6]	18,00 x 11 x 66,0	G1			1545135 421297	<b>81-47104</b>
	EX [1]	18,00 x 11 x 66,0	G1			11129092	<b>81-47124</b> <small>NEW</small>
		1072 mm				4687232 478750 4796207 81937278	<b>20 1004 12200</b>
	[12]	M 36 x 72				15455397 15455405 4223186 4790317 4798633	<b>20 1004 12001</b>
	[12]	M 36 x 72				1535539	<b>20 1004 12003</b>

**V**

					Reference	Item No.	
<b>125</b>		<b>130,175</b>					
<b>TAD 121</b>	<b>CHC</b> 1983 → 1988	D (NA) 6	11980 cm <sup>3</sup> 2V	238 kW	(324 PS) 14,2:1	150,00 mm	
<b>TAMD 120</b>	<b>A, B</b> 1977 → 1984	D (LA) 6	12000 cm <sup>3</sup> 2V	227-294 kW	(308-400 PS) 14,2:1	150,00 mm	
<b>TAMD 121</b>	<b>C</b> 03.1983 → 1986	D (LA) 6	12000 cm <sup>3</sup> 2V	300 kW	(408 PS) 14,2:1	150,00 mm	
<b>TAMD 121</b>	<b>D</b> 1983 → 1988	D (A) 6	12000 cm <sup>3</sup> 2V	217-310 kW	(295-420 PS) 14,2:1	150,00 mm	
<b>TAMD 122</b>	<b>C, D</b> 1988 →	D (LA) 6	12000 cm <sup>3</sup> 2V	127-340 kW	(173-462 PS) 14,2:1	150,00 mm	
<b>TID 120</b>	<b>FG</b>	D (LA) 6	12000 cm <sup>3</sup> 2V	217-264 kW	(295-359 PS) 13,3:1	150,00 mm	
<b>TID 121</b>	<b>FG, KG, KGP, LG, LGP, LP</b> 01.1986 →	D (LA) 6	12000 cm <sup>3</sup> 2V	217-305 kW	(295-415 PS)	150,00 mm	
<b>TMD 120</b>	<b>A, B</b> 1977 → 1983	D (A) 6	12000 cm <sup>3</sup> 2V	169-243 kW	(230-330 PS) 15:1	150,00 mm	
<b>TMD 121</b>	<b>C</b> 1984 → 1988	D (LA) 6	12000 cm <sup>3</sup> 2V	164-243 kW	(223-330 PS) 14,2:1	150,00 mm	
41 221 6..., 41 227 6..., 90 924 6..., 93 249 6..., 93 250 6..., 93 369 7..., 99 488 6...							
	IN [1]	54,0 x 11 x 167,3	S - Cr -	- 30° - -	9 - III	468302 468302-5 460803 460803-3 468303 468303-3	<b>105-34949</b>  <b>48303</b>
	EX [1]	50,0 x 11 x 167,3	A/S - Cr -	- 45° - VS -	9 - III		
	IN [6]	17,98 x 11 x 82,0	G2			422320	<b>81-47117</b>
	IN [6]	18,03 x 11 x 82,0	G1			1545135	<b>81-47109</b>
	EX [6]	18,00 x 11 x 66,0	G1			421297	<b>81-47104</b>
	EX [1]	18,00 x 11 x 66,0	G1			11129092	<b>81-47124</b>
	IN [2]	59,12 x 49 x 6,8	G1 30°			423011	<b>92-47007</b>
	EX [2]	56,60 x 44.95 x 9,4	G1 45°			468448	<b>92-47009</b>
	EX [2]	58,30 x 49 x 6,8	G1 45°			423208	<b>92-47008</b>
<b>126</b>		<b>130,175</b>					
<b>TD 120</b>	<b>F, FA, FB, FC, FTQ</b> 01.1976 →	D (LA) 6	11980 cm <sup>3</sup> 2V	213-265 kW	(290-360 PS) 14,2:1	150,00 mm	
<b>TD 120</b>	<b>A, C, D, E, G, GA, GG</b> 10.1970 →	D (A) 6	2V	178-273 kW	(242-371 PS)	150,00 mm	
<b>TD 121</b>	<b>FA, FB, FC, FD, FE, FF, FG, FH, FK, GG, GP</b> 01.1981 →	D (LA) 6	2V	206-283 kW	(280-385 PS)	150,00 mm	
<b>TD 121</b>	<b>A</b> 07.1986 → 01.1998	D (A) 6	12000 cm <sup>3</sup> 2V	243 kW	(330 PS) 14,2:1	150,00 mm	
<b>TD 122</b>	<b>ED, F (USA), FAQ, FBQ, FCQ, FK, FKQ, FR, GA, GB, GH, KBE, KE, KHD</b> 1980 →	D (LA) 6	2V	179-396 kW	(243-538 PS)	150,00 mm	
<b>TD 122</b>	<b>FA, FTO</b> 01.1987 →	D (A) 6	11980 cm <sup>3</sup> 2V	221-396 kW	(300-538 PS) 16:1	150,00 mm	
<b>TD 123 Euro 1</b>	<b>EC, ED</b> 01.1991 →	D (LA) 6	11980 cm <sup>3</sup> 2V	270-301 kW	(367-410 PS) 17,8:1	150,00 mm	
<b>TD 123 Euro 1</b>	<b>EA, EB</b>	D (A) 6	11980 cm <sup>3</sup> 2V	224-301 kW	(305-409 PS) 17,8:1	150,00 mm	
<b>TD 123</b>	<b>F</b>	D (A) 6	12000 cm <sup>3</sup> 2V		17,8:1	150,00 mm	
41 221 6..., 41 227 6..., 90 081 6..., 90 870 6..., 90 924 6..., 93 249 6..., 93 250 6..., 93 369 7..., 99 966 6...							
	IN [1]	54,0 x 11 x 167,3	S - Cr -	- 30° - -	9 - III	468302 468302-5 460803 460803-3 468303 468303-3	<b>105-34949</b>  <b>48303</b>
	EX [1]	50,0 x 11 x 167,3	A/S - Cr -	- 45° - VS -	9 - III		
Fortsetzung nächste Seite / continued on next page / suite page suivante / continuación página próxima / Продолжение на следующей странице							

					Reference	Item No.
[50]	Ø 11 mm				468305	RK-11H
IN [6]	17,98 x 11 x 82,0	G2				81-47117
IN [6]	18,03 x 11 x 82,0	G1			422320	81-47109
EX [6]	18,00 x 11 x 66,0	G1			1545135	81-47104
EX [1]	18,00 x 11 x 66,0	G1			421297	
EX [1]	18,00 x 11 x 66,0	G1			11129092	81-47124 <b>NEW</b>
IN [2]	59,12 x 49 x 6,8	G1 30°			423011	92-47007
EX [2]	56,60 x 44.95 x 9,4	G1 45°			468448	92-47009
EX [2]	58,30 x 49 x 6,8	G1 45°			423208	92-47008 <b>NEW</b>
	1072 mm				4687232	20 1004 12200
					478750	
					4796207	
					81937278	
[12]	M 36 x 72				15455397	20 1004 12001
					15455405	
					4223186	
					4790317	
					4798633	
[12]	M 36 x 72				1535539	20 1004 12003

## 127 130,175

<b>TAD 120</b>	<b>BHC</b>								
		D (A)	6	11980 cm <sup>3</sup>	2V	225-273 kW	(306-371 PS)	13,3:1	150,00 mm
<b>TAMD 120</b>	<b>AK, BCC</b>								
	1980 → 1984	D (LA)	6	12000 cm <sup>3</sup>	2V	227-265 kW	(308-360 PS)	14,2:1	150,00 mm
<b>TAMD 122</b>	<b>A, P-A, P-B, P-C</b>								
	03.1988 → 2002	D (LA)	6	12000 cm <sup>3</sup>	2V	135-449 kW	(183-610 PS)	14,2:1	150,00 mm
<b>TID 121</b>	<b>KP</b>								
	10.1987 →	D (LA)	6	12000 cm <sup>3</sup>	2V	217-305 kW	(295-415 PS)	13,3:1	150,00 mm
<b>TMD 122</b>	<b>A</b>								
	01.1988 → 2000	D (LA)	6	12000 cm <sup>3</sup>	2V	221-235 kW	(300-320 PS)	14,2:1	150,00 mm

41 221 6.., 41 227 6.., 90 924 6.., 93 249 6.., 93 369 7.., 99 488 6..

IN [6]	17,98 x 11 x 82,0	G2							81-47117
IN [6]	18,03 x 11 x 82,0	G1				422320			81-47109
EX [6]	18,00 x 11 x 66,0	G1				1545135			81-47104
						421297			
EX [1]	18,00 x 11 x 66,0	G1				11129092			81-47124 <b>NEW</b>
IN [2]	59,12 x 49 x 6,8	G1 30°				423011			92-47007
EX [2]	56,60 x 44.95 x 9,4	G1 45°				468448			92-47009
EX [2]	58,30 x 49 x 6,8	G1 45°				423208			92-47008 <b>NEW</b>

## 128 130,175

<b>TID 121</b>	<b>KPB</b>								
	10.1987 →	D (LA)	6	12000 cm <sup>3</sup>	2V	217-305 kW	(295-415 PS)	13,3:1	150,00 mm

99 488 6..

IN [2]	59,12 x 49 x 6,8	G1 30°				423011			92-47007
EX [2]	56,60 x 44.95 x 9,4	G1 45°				468448			92-47009
EX [2]	58,30 x 49 x 6,8	G1 45°				423208			92-47008 <b>NEW</b>

## 129 130,175

<b>TID 121</b>	<b>LPB</b>								
	1988 →	D (LA)	6	12000 cm <sup>3</sup>	2V	217-305 kW	(295-415 PS)	13,3:1	150,00 mm

99 488 6..

IN [6]	17,98 x 11 x 82,0	G2							81-47117
IN [6]	18,03 x 11 x 82,0	G1				422320			81-47109
EX [6]	18,00 x 11 x 66,0	G1				1545135			81-47104
						421297			
EX [1]	18,00 x 11 x 66,0	G1				11129092			81-47124 <b>NEW</b>

					Reference	Item No.
<b>130</b> <b>130,175</b> <b>TWD 1210 Euro 1 G</b> 09.1991 → D (LA) 6 12000 cm <sup>3</sup> 2V 160-294 kW (218-400 PS) 13,3:1 150,00 mm 99 488 6..						
	IN [1] EX [1]	54,0 x 11 x 167,3 50,0 x 11 x 167,3	S - Cr - A/S - Cr -	- 30° - - - 45° - VS -	9 - III 9 - III	468302 468302-5 460803 460803-3 468303 468303-3  105-34949  48303
	IN/EX [6]	15,00 x 8.02 x 83,2	G2			1546437 20817645 20817648 20904074 20905400 20919484 3165303 3183283  81-47114
	IN [2] EX [2] EX [2]	59,12 x 49 x 6,8 56,60 x 44.95 x 9,4 58,30 x 49 x 6,8	G1 30° G1 45° G1 45°			423011 468448 423208  92-47007 92-47009 92-47008 <b>NEW</b>
<b>131</b> <b>130,175</b> <b>TD 1210 G</b> 10.1991 → D (LA) 6 12000 cm <sup>3</sup> 2V 230 kW (313 PS) 150,00 mm 99 966 6..						
	IN [1] EX [1]	54,0 x 11 x 167,3 50,0 x 11 x 167,3	S - Cr - A/S - Cr -	- 30° - - - 45° - VS -	9 - III 9 - III	468302 468302-5 460803 460803-3 468303 468303-3  105-34949  48303
	IN/EX [6]	15,00 x 8.01 x 83,4	G2			1546437 20817645 20817648 20904074 20905400 20919484 3165303 3183283  81-47119
	IN/EX [6]	15,00 x 8.02 x 83,2	G2			1546437 20817645 20817648 20904074 20905400 20919484 3165303 3183283  81-47114
	IN [2] EX [2] EX [2]	59,12 x 49 x 6,8 56,60 x 44.95 x 9,4 58,30 x 49 x 6,8	G1 30° G1 45° G1 45°			423011 468448 423208  92-47007 92-47009 92-47008 <b>NEW</b>
		1072 mm				4687232 478750 4796207 81937278  20 1004 12200
	[12]	M 36 x 72				15455397 15455405 4223186 4790317 4798633 1535539  20 1004 12001
	[12]	M 36 x 72				1535539  20 1004 12003

V



					Reference	Item No.	
<b>132</b>		<b>130,175</b>					
<b>TAD 1230</b>	<b>G</b>	01.1993 →	D (LA) 6	11980 cm <sup>3</sup> 2V	294-349 kW (400-475 PS) 16:1	150,00 mm	
<b>TWD 1211</b>	<b>G, V</b>	1993 →	D (LA) 6	12000 cm <sup>3</sup> 2V	260-325 kW (354-442 PS)	150,00 mm	
<b>TWD 1230</b>	<b>VE</b>		D (LA) 6	12000 cm <sup>3</sup> 2V		150,00 mm	
<b>TWD 1231</b>	<b>VE</b>		D (LA) 6	12000 cm <sup>3</sup> 2V	310 kW (422 PS)	150,00 mm	
99 966 6..							
	IN [1]	54,0 x 11 x 167,3	S - Cr -	- 30° - -	9 - III	468302 468302-5	<b>105-34949</b>
	EX [1]	50,0 x 11 x 167,3	A/S - Cr -	- 45° - VS -	9 - III	460803 460803-3 468303 468303-3	<b>48303</b>
	IN/EX [6]	15,00 x 8.01 x 83,4	G2			1546437 20817645 20817648 20904074 20905400 20919484 3165303 3183283	<b>81-47119</b>
	IN/EX [6]	15,00 x 8.02 x 83,2	G2			1546437 20817645 20817648 20904074 20905400 20919484 3165303 3183283	<b>81-47114</b>
	IN [2]	59,12 x 49 x 6,8	G1 30°			423011	<b>92-47007</b>
	EX [2]	56,60 x 44.95 x 9,4	G1 45°			468448	<b>92-47009</b>
	EX [2]	58,30 x 49 x 6,8	G1 45°			423208	<b>92-47008</b> <small>NEW</small>
<b>133</b>		<b>130,175</b>					
<b>TAD 1231 Euro 1</b>	<b>GE</b>	1993 →	D (LA) 6	11980 cm <sup>3</sup> 2V	260-304 kW (354-413 PS) 16:1	150,00 mm	
<b>TAD 1232 Euro 1</b>	<b>GE</b>	1993 →	D (LA) 6	11980 cm <sup>3</sup> 2V	300-354 kW (408-481 PS) 17,5:1	150,00 mm	
99 966 6..							
	IN [1]	54,0 x 11 x 167,3	S - Cr -	- 30° - -	9 - III	468302 468302-5	<b>105-34949</b>
	EX [1]	50,0 x 11 x 167,3	A/S - Cr -	- 45° - VS -	9 - III	460803 460803-3 468303 468303-3	<b>48303</b>
Fortsetzung nächste Seite / continued on next page / suite page suivante / continuación página próxima / Продолжение на следующей странице							

**V**

					Reference	Item No.
	IN/EX [6] 15,00 x 8.01 x 83,4	G2			1546437 20817645 20817648 20904074 20905400 20919484 3165303 3183283	<b>81-47119</b>
	IN/EX [6] 15,00 x 8.02 x 83,2	G2			1546437 20817645 20817648 20904074 20905400 20919484 3165303 3183283	<b>81-47114</b>

## 134 130,175

<b>TWD 1210</b>	<b>P</b>	D (LA)	6	12000 cm <sup>3</sup>	2V	150,00 mm
<b>TWD 1211</b>	<b>P</b>	D (LA)	6	12000 cm <sup>3</sup>	2V	150,00 mm

99 966 6..

	IN [1] 54,0 x 11 x 167,3	S - Cr -	- 30° - -	9 - III	468302 468302-5	<b>105-34949</b>
	EX [1] 50,0 x 11 x 167,3	A/S - Cr -	- 45° - VS -	9 - III	460803 460803-3 468303 468303-3	<b>48303</b>
	IN [2] 59,12 x 49 x 6,8	G1 30°			423011	<b>92-47007</b>
	EX [2] 56,60 x 44.95 x 9,4	G1 45°			468448	<b>92-47009</b>
	EX [2] 58,30 x 49 x 6,8	G1 45°			423208	<b>92-47008</b> <small>NEW</small>

## 135 130,18

<b>TD 122 Euro 1</b>	<b>FH</b>	D (LA)	6	11980 cm <sup>3</sup>	2V	262 kW (356 PS)	16:1	150,00 mm
<b>TD 122</b>	<b>FL</b>	D (LA)	6	11980 cm <sup>3</sup>	2V	291 kW (396 PS)	16:1	150,00 mm
<b>TD 123 Euro 1</b>	<b>E, ES</b>	D (A)	6	11980 cm <sup>3</sup>	2V	262-298 kW (356-405 PS)	17,8:1	150,00 mm

90 081 6.., 90 870 6..

	IN [1] 54,0 x 11 x 167,3	S - Cr -	- 30° - -	9 - III	468302 468302-5	<b>105-34949</b>
	EX [1] 50,0 x 11 x 167,3	A/S - Cr -	- 45° - VS -	9 - III	460803 460803-3 468303 468303-3	<b>48303</b>
	[50] Ø 11 mm				468305	<b>RK-11H</b>
	IN [6] 17,98 x 11 x 82,0	G2			422320	<b>81-47117</b>
	IN [6] 18,03 x 11 x 82,0	G1			1545135	<b>81-47109</b>
	EX [6] 18,00 x 11 x 66,0	G1			421297	<b>81-47104</b>
	EX [1] 18,00 x 11 x 66,0	G1			11129092	<b>81-47124</b> <small>NEW</small>
	IN [2] 59,12 x 49 x 6,8	G1 30°			423011	<b>92-47007</b>
	EX [2] 56,60 x 44.95 x 9,4	G1 45°			468448	<b>92-47009</b>
	EX [2] 58,30 x 49 x 6,8	G1 45°			423208	<b>92-47008</b> <small>NEW</small>
	1072 mm				4687232 478750 4796207 81937278	<b>20 1004 12200</b>

Fortsetzung nächste Seite / continued on next page / suite page suivante / continuación página próxima / Продолжение на следующей странице

					Reference	Item No.
[12]	M 36 x 72				15455397 15455405 4223186 4790317 4798633	20 1004 12001
[12]	M 36 x 72				1535539	20 1004 12003
<b>136</b> <b>131</b>						
<b>D12A340 Euro 2</b> 08.1993 → D (LA) 6 12130 cm <sup>3</sup> 4V 250 kW (340 PS) 17,5:1 150,00 mm						
<b>D12A380 Euro 2</b> 08.1993 → D (LA) 6 12130 cm <sup>3</sup> 4V 279 kW (380 PS) 17,5:1 150,00 mm						
<b>D12A420 Euro 2</b> 08.1993 → D (LA) 6 12130 cm <sup>3</sup> 4V 309 kW (420 PS) 17,5:1 150,00 mm						
<b>D12B340 Euro 2</b> D (LA) 6 12130 cm <sup>3</sup> 4V 250 kW (340 PS) 150,00 mm						
40 265 6.., 40 338 6..						
IN [2]	40,0 x 8 x 192,1	S - Cr -	- 30° - -	9 - III	1547492 3169490	<b>48225</b>
EX [2]	40,0 x 8 x 191,7	RA/S- Cr -	- 45° - -	9 - III	20441486 3165234 8148574	<b>48227</b>
[50]	Ø 8 mm				1677875	<b>RK-8H</b>
IN/EX [6]	15,00 x 8.01 x 83,4	G2			1546437 20817645 20817648 20904074 20905400 20919484 3165303 3183283	<b>81-47119</b>
IN/EX [6]	15,00 x 8.02 x 83,2	G2			1546437 20817645 20817648 20904074 20905400 20919484 3165303 3183283	<b>81-47114</b>
IN [2]	43,10 x 32 x 7,2	G1 30°			20459329 20482579 21484829	<b>92-47019</b>
IN [1]	43,05 x 32 x 7,2	G1 30°				<b>92-47032</b>
EX [2]	43,08 x 32.9 x 8,0	G1 45°			20412798 21484834 3169366	<b>92-47020</b>
EX [1]	43,10 x 32.9 x 8,0	G1 45°				<b>92-47033</b>
	1070 mm				8148524 3964764	<b>20 1004 12004</b> (1) <b>20 1004 12008</b> (2)
(1)	VEB.ENG-93097					
(2)	VEB.ENG 93098-.MARK II					
IN [2]					20738717 21024794	<b>20 1004 12100</b>
EX [1]					20381702 20738748 21023450 21089229 21504759 21881195	<b>20 1004 12101</b>
[2]					20738736 21024789	<b>20 1004 12102</b> (3)
(3)	Injector					

V

					Reference	Item No.		
<b>137</b>		<b>131</b>						
<b>D12C340 Euro 2</b>	08.1998 →	D (LA)	6	12130 cm <sup>3</sup>	4V	250 kW (340 PS)	18,5:1	150,00 mm
<b>D12C380 Euro 3</b>	08.1993 →	D (LA)	6	12130 cm <sup>3</sup>	4V	279 kW (380 PS)	18,5:1	150,00 mm
<b>D12C460 Euro 3</b>	01.1997 →	D (LA)	6	12130 cm <sup>3</sup>	4V	338 kW (460 PS)	18,5:1	150,00 mm
40 100 6.., 40 338 6..								
	IN [2]	40,0 x 8 x 191,9	S - Cr -	- 30° - VS -	9 - III	20459326 20463800	<b>48327</b>	
	EX [2]	40,0 x 8 x 191,6	A/S - Cr -	- 45° - VS -	9 - III	20441945	<b>48328</b>	
	[50]	∅ 8 mm				1677875	<b>RK-8H</b>	
	IN/EX [6]	15,00 x 8.01 x 83,4	G2			1546437 20817645 20817648 20904074 20905400 20919484 3165303 3183283	<b>81-47119</b>	
	IN/EX [6]	15,00 x 8.02 x 83,2	G2			1546437 20817645 20817648 20904074 20905400 20919484 3165303 3183283	<b>81-47114</b>	
	IN [2]	43,10 x 32 x 7,2	G1 30°			20459329 20482579 21484829	<b>92-47019</b>	
	IN [1]	43,05 x 32 x 7,2	G1 30°				<b>92-47032</b>	
	EX [2]	43,08 x 32.9 x 8,0	G1 45°			20412798 21484834 3169366	<b>92-47020</b>	
	EX [1]	43,10 x 32.9 x 8,0	G1 45°				<b>92-47033</b>	
						3165423	<b>20 1004 12005</b> <small>NEW</small>	
	IN [2]					20738717 21024794	<b>20 1004 12100</b>	
	EX [1]					20381702 20738748 21023450 21089229 21504759 21881195	<b>20 1004 12101</b>	
	[2]					20738736 21024789	<b>20 1004 12102</b> (1)	
	(1) Injector							
<b>138</b>		<b>131</b>						
<b>D12C420 Euro 3</b>	08.1993 →	D (LA)	6	12130 cm <sup>3</sup>	4V	309 kW (420 PS)	18,5:1	150,00 mm
40 100 6.., 40 338 6..								
	IN [2]	40,0 x 8 x 191,9	S - Cr -	- 30° - VS -	9 - III	20459326 20463800	<b>48327</b>	
	EX [2]	40,0 x 8 x 191,6	A/S - Cr -	- 45° - VS -	9 - III	20441945	<b>48328</b>	
	[50]	∅ 8 mm				1677875	<b>RK-8H</b>	
Fortsetzung nächste Seite / continued on next page / suite page suivante / continuación página próxima / Продолжение на следующей странице								

					Reference	Item No.
	IN/EX [6] 15,00 x 8.01 x 83,4	G2			1546437 20817645 20817648 20904074 20905400 20919484 3165303 3183283	<b>81-47119</b>
	IN/EX [6] 15,00 x 8.02 x 83,2	G2			1546437 20817645 20817648 20904074 20905400 20919484 3165303 3183283	<b>81-47114</b>
	IN [2] 43,10 x 32 x 7,2	G1 30°			20459329 20482579 21484829	<b>92-47019</b>
	IN [1] 43,05 x 32 x 7,2	G1 30°				<b>92-47032</b>
	EX [2] 43,08 x 32.9 x 8,0	G1 45°			20412798 21484834 3169366	<b>92-47020</b>
	EX [1] 43,10 x 32.9 x 8,0	G1 45°				<b>92-47033</b>
					3165423 316 5224	<b>20 1004 12005</b> <small>NEW</small> <b>20 1004 12006</b>
	IN [2] EX [1]				20738717 21024794 20381702 20738748 21023450 21089229 21504759 21881195	<b>20 1004 12100</b> <b>20 1004 12101</b>
	[2]  (1) Injector				20738736 21024789	<b>20 1004 12102</b> (1)

## 139 131

<b>D12D340 Euro 3</b>	08.1998 →	D (LA)	6	12130 cm <sup>3</sup>	4V	250 kW	(340 PS)	18,1:1	150,00 mm
<b>D12D380 Euro 3</b>	08.1993 →	D (LA)	6	12130 cm <sup>3</sup>	4V	279 kW	(379 PS)	18,1:1	150,00 mm
<b>D12D460 Euro 3</b>	08.1998 →	D (LA)	6	12130 cm <sup>3</sup>	4V	338 kW	(460 PS)	18,1:1	150,00 mm
<b>D12D500 Euro 3</b>	09.1998 →	D (LA)	6	12130 cm <sup>3</sup>	4V	368 kW	(500 PS)	18,1:1	150,00 mm

40 100 6.., 40 338 6..

	IN [2] EX [2]	40,0 x 8 x 191,9 40,0 x 8 x 191,6	S - Cr - A/S - Cr -	- 30° - VS - - 45° - VS -	9 - III 9 - III	20459326 20463800 20441945	<b>48327</b> <b>48328</b>
	[50]	∅ 8 mm				1677875	<b>RK-8H</b>

Fortsetzung nächste Seite / continued on next page / suite page suivante / continuación página próxima / Продолжение на следующей странице

					Reference	Item No.
	IN/EX [6] 15,00 x 8.01 x 83,4	G2			1546437 20817645 20817648 20904074 20905400 20919484 3165303 3183283	<b>81-47119</b>
	IN/EX [6] 15,00 x 8.02 x 83,2	G2			1546437 20817645 20817648 20904074 20905400 20919484 3165303 3183283	<b>81-47114</b>
	IN [2] 43,10 x 32 x 7,2	G1 30°			20459329 20482579 21484829	<b>92-47019</b>
	IN [1] 43,05 x 32 x 7,2	G1 30°				<b>92-47032</b>
	EX [2] 43,08 x 32.9 x 8,0	G1 45°			20412798 21484834 3169366	<b>92-47020</b>
	EX [1] 43,10 x 32.9 x 8,0	G1 45°				<b>92-47033</b>
	IN [2]				20738717 21024794 20381702 20738748 21023450 21089229 21504759 21881195	<b>20 1004 12100</b>
	EX [1]					<b>20 1004 12101</b>
	[2]				20738736 21024789	<b>20 1004 12102 (1)</b>
	(1) Injector					

**140**
**131**

**D12D420 Euro 3** 08.1993 → D (LA) 6 12130 cm<sup>3</sup> 4V 309 kW (420 PS) 18,1:1 150,00 mm  
40 100 6..., 40 338 6..

	IN [2] 40,0 x 8 x 191,9	S - Cr -	- 30° - VS -	9 - III	20459326 20463800	<b>48327</b>
	EX [2] 40,0 x 8 x 191,6	A/S - Cr -	- 45° - VS -	9 - III	20441945	<b>48328</b>
	[50] Ø 8 mm				1677875	<b>RK-8H</b>
	IN/EX [6] 15,00 x 8.01 x 83,4	G2			1546437 20817645 20817648 20904074 20905400 20919484 3165303 3183283	<b>81-47119</b>
	IN/EX [6] 15,00 x 8.02 x 83,2	G2			1546437 20817645 20817648 20904074 20905400 20919484 3165303 3183283	<b>81-47114</b>

Fortsetzung nächste Seite / continued on next page / suite page suivante / continuación página próxima / Продолжение на следующей странице



					Reference	Item No.
IN [2]	43,10 x 32 x 7,2	G1 30°			20459329 20482579 21484829	92-47019
IN [1] EX [2]	43,05 x 32 x 7,2 43,08 x 32.9 x 8,0	G1 30° G1 45°			20412798 21484834 3169366	92-47032 92-47020
EX [1]	43,10 x 32.9 x 8,0	G1 45°				92-47033
					316 5224	20 1004 12006
IN [2] EX [1]					20738717 21024794 20381702 20738748 21023450 21089229 21504759 21881195 20738736 21024789	20 1004 12100 20 1004 12101
[2] (1) Injector						20 1004 12102 (1)

**141**
**131**
**D 12 Euro 2**
**A 370, A 415**

10.1995 →

 D (LA) 6 12130 cm<sup>3</sup> 4V 272-305 kW (370-415 PS) 17,5:1 150,00 mm

40 265 6..

IN [2] EX [2]	40,0 x 8 x 192,1 40,0 x 8 x 191,7	S - Cr - RA/S- Cr -	- 30° - - - 45° - -	9 - III 9 - III	1547492 3169490 20441486 3165234 8148574	48225 48227
[50]	∅ 8 mm				1677875	RK-8H
IN/EX [6]	15,00 x 8.01 x 83,4	G2			1546437 20817645 20817648 20904074 20905400 20919484 3165303 3183283	81-47119
IN/EX [6]	15,00 x 8.02 x 83,2	G2			1546437 20817645 20817648 20904074 20905400 20919484 3165303 3183283	81-47114
IN [2] IN [1] EX [2]	43,10 x 32 x 7,2 43,05 x 32 x 7,2 43,08 x 32.9 x 8,0	G1 30° G1 30° G1 45°			20459329 20482579 21484829 20412798 21484834 3169366	92-47019 92-47032 92-47020
EX [1]	43,10 x 32.9 x 8,0	G1 45°				92-47033
	1070 mm				8148524 3964764	20 1004 12004 (1) 20 1004 12008 (2)

Fortsetzung nächste Seite / continued on next page / suite page suivante / continuación página próxima / Продолжение на следующей странице

					Reference	Item No.
(1)	VEB.ENG-93097					
(2)	VEB.ENG 93098-.MARK II					

## 142 131

D 12 Euro 2	D-B MP								
D 12 Euro 3	D-G MP, D-H MP	D (LA)	6	12130 cm <sup>3</sup>	4V			17,5:1	150,00 mm
D12D425 Euro 3		D (LA)	6	12130 cm <sup>3</sup>	4V				150,00 mm
D12F390 Euro 4		D (LA)	6	12130 cm <sup>3</sup>	4V	317 kW	(431 PS)	18,1:1	150,00 mm
D12F430 Euro 4	09.2001 → 09.2005	D (LA)	6	12130 cm <sup>3</sup>	4V	287 kW	(390 PS)	17,3:1	150,00 mm
DH 12 Euro 3	09.2001 → 09.2005	D (LA)	6	12130 cm <sup>3</sup>	4V	316 kW	(430 PS)	17,3:1	150,00 mm
DH12D340 Euro 3	H 340 09.2001 →	D (LA)	6	12130 cm <sup>3</sup>	4V	249 kW	(340 PS)	18,5:1	150,00 mm
DH12D380 Euro 3	01.1999 →	D (LA)	6	12130 cm <sup>3</sup>	4V	250 kW	(340 PS)	18,5:1	150,00 mm
DH12D420 Euro 3	01.1999 →	D (LA)	6	12130 cm <sup>3</sup>	4V	280 kW	(380 PS)	18,5:1	150,00 mm
DH12E340 Euro 5	01.1997 →	D (LA)	6	12130 cm <sup>3</sup>	4V	309 kW	(420 PS)	18,5:1	150,00 mm
DH12E380 Euro 4	10.2007 →	D (LA)	6	12130 cm <sup>3</sup>	4V	250 kW	(340 PS)	18,1:1	150,00 mm
DH12E420 Euro 5	02.2006 →	D (LA)	6	12130 cm <sup>3</sup>	4V	280 kW	(380 PS)	18,1:1	150,00 mm
DH12E460 Euro 4	10.2007 →	D (LA)	6	12130 cm <sup>3</sup>	4V	309 kW	(420 PS)	18,1:1	150,00 mm
	10.2007 →	D (LA)	6	12130 cm <sup>3</sup>	4V	338 kW	(460 PS)	18,1:1	150,00 mm

40 338 6.., 41 254 6.., 41 256 6.., 41 262 6..

	IN [2]	40,0 x 8 x 191,9	S - Cr -	- 30° - VS -	9 - III	20459326 20463800	<b>48327</b>
	EX [2]	40,0 x 8 x 191,6	A/S - Cr -	- 45° - VS -	9 - III	20441945	<b>48328</b>
	[50]	Ø 8 mm				1677875	<b>RK-8H</b>
	IN/EX [6]	15,00 x 8.01 x 83,4	G2			1546437 20817645 20817648 20904074 20905400 20919484 3165303 3183283	<b>81-47119</b>
	IN/EX [6]	15,00 x 8.02 x 83,2	G2			1546437 20817645 20817648 20904074 20905400 20919484 3165303 3183283	<b>81-47114</b>
	IN [2]	43,10 x 32 x 7,2	G1 30°			20459329 20482579 21484829	<b>92-47019</b>
	IN [1]	43,05 x 32 x 7,2	G1 30°				<b>92-47032</b>
	EX [2]	43,08 x 32.9 x 8,0	G1 45°			20412798 21484834 3169366	<b>92-47020</b>
	EX [1]	43,10 x 32.9 x 8,0	G1 45°				<b>92-47033</b>

					Reference	Item No.	
<b>143</b>		<b>131</b>					
<b>D 12</b>	<b>C</b>	01.1998 →	D	6	12000 cm <sup>3</sup> 2V	331 kW (450 PS) 18,5:1	150,00 mm
						316 5224	<b>20 1004 12006</b>
<b>144</b>		<b>131</b>					
<b>D 12 Euro 2</b>	<b>C-A MP</b>	1999 → 2004	D (LA)	6	12130 cm <sup>3</sup> 4V	452-526 kW (615-715 PS) 16,5:1	150,00 mm
	IN/EX [6]	15,00 x 8.01 x 83,4	G2			1546437 20817645 20817648 20904074 20905400 20919484 3165303 3183283	<b>81-47119</b>
	IN/EX [6]	15,00 x 8.02 x 83,2	G2			1546437 20817645 20817648 20904074 20905400 20919484 3165303 3183283	<b>81-47114</b>
<b>145</b>		<b>131</b>					
<b>TAD1240GE Euro 2</b>	01.2001 →	D (LA)	6	12130 cm <sup>3</sup> 4V	310-346 kW (421-470 PS) 17,5:1	150,00 mm	
<b>TAD1241GE Euro 2</b>	01.2001 →	D (LA)	6	12130 cm <sup>3</sup> 4V	323-387 kW (439-526 PS) 17,5:1	150,00 mm	
<b>TAD1242GE Euro 2</b>	01.2001 →	D (LA)	6	12130 cm <sup>3</sup> 4V	352-430 kW (479-585 PS) 17,5:1	150,00 mm	
<b>TWD1240VE Euro 2</b>	01.2001 →	D (LA)	6	12130 cm <sup>3</sup> 4V	294-310 kW (400-421 PS) 18,5:1	150,00 mm	
	IN [2]	40,0 x 8 x 191,9	S - Cr -	- 30° - VS -	9 - III	20459326 20463800	<b>48327</b>
	IN [2]	40,0 x 8 x 192,1	S - Cr -	- 30° -	9 - III	1547492 3169490	<b>48225</b>
	EX [2]	40,0 x 8 x 191,7	RA/S- Cr -	- 45° -	9 - III	20441486 3165234 8148574	<b>48227</b>
	[50]	Ø 8 mm				1677875	<b>RK-8H</b>
	IN/EX [6]	15,00 x 8.01 x 83,4	G2			1546437 20817645 20817648 20904074 20905400 20919484 3165303 3183283	<b>81-47119</b>
	IN/EX [6]	15,00 x 8.02 x 83,2	G2			1546437 20817645 20817648 20904074 20905400 20919484 3165303 3183283	<b>81-47114</b>
Fortsetzung nächste Seite / continued on next page / suite page suivante / continuación página próxima / Продолжение на следующей странице							

**V**

					Reference	Item No.
IN [2]	43,10 x 32 x 7,2	G1 30°			20459329 20482579 21484829	<b>92-47019</b>
IN [1]	43,05 x 32 x 7,2	G1 30°				<b>92-47032</b>
EX [2]	43,08 x 32.9 x 8,0	G1 45°			20412798 21484834 3169366	<b>92-47020</b>
EX [1]	43,10 x 32.9 x 8,0	G1 45°				<b>92-47033</b>

## 146 131

<b>D 12 Euro 3</b>	<b>D-E MP</b> 2008 →	D (LA)	6	12130 cm <sup>3</sup>	4V	478-496 kW	(650-675 PS)	16,5:1	150,00 mm
<b>D 12 Euro 2</b>	<b>D-A MG, D-A MP</b> 2002 → 2008	D (LA)	6	12130 cm <sup>3</sup>	4V	292-526 kW	(397-715 PS)		150,00 mm
<b>TAD1241VE Euro 2</b>	2002 →	D (LA)	6	12130 cm <sup>3</sup>	4V	343 kW	(466 PS)	17,5:1	150,00 mm
<b>TAD1242VE Euro 2</b>	01.2002 →	D (LA)	6	12130 cm <sup>3</sup>	4V	383 kW	(521 PS)	17,5:1	150,00 mm

IN/EX [6]	15,00 x 8.01 x 83,4	G2				1546437 20817645 20817648 20904074 20905400 20919484 3165303 3183283	<b>81-47119</b>
IN/EX [6]	15,00 x 8.02 x 83,2	G2				1546437 20817645 20817648 20904074 20905400 20919484 3165303 3183283	<b>81-47114</b>
IN [2]	43,10 x 32 x 7,2	G1 30°				20459329 20482579 21484829	<b>92-47019</b>
IN [1]	43,05 x 32 x 7,2	G1 30°					<b>92-47032</b>
EX [2]	43,08 x 32.9 x 8,0	G1 45°				20412798 21484834 3169366	<b>92-47020</b>
EX [1]	43,10 x 32.9 x 8,0	G1 45°					<b>92-47033</b>

## V 147 131

<b>D 12 Euro 3</b>	<b>D-C MH, D-E MH</b> 2006 →	D (LA)	6	12130 cm <sup>3</sup>	4V	216-405 kW	(294-550 PS)	17,5:1	150,00 mm
<b>D 12 Euro 2</b>	<b>D-A MH, D-B MH</b> 2002 → 2006	D (LA)	6	12130 cm <sup>3</sup>	4V	294-405 kW	(400-550 PS)	17,5:1	150,00 mm

Fortsetzung nächste Seite / continued on next page / suite page suivante / continuación página próxima / Продолжение на следующей странице

					Reference	Item No.	
	IN/EX [6] 15,00 x 8.01 x 83,4	G2			1546437 20817645 20817648 20904074 20905400 20919484 3165303 3183283	<b>81-47119</b>	
	IN/EX [6] 15,00 x 8.02 x 83,2	G2			1546437 20817645 20817648 20904074 20905400 20919484 3165303 3183283	<b>81-47114</b>	
	IN [2] 43,08 x 31.9 x 8,5	G1 30°			1547810 20459329 21484829 3183227	<b>92-47026</b>	
	IN [2] 43,10 x 32 x 7,2	G1 30°			20459329 20482579 21484829	<b>92-47019</b>	
	IN [1] 43,05 x 32 x 7,2	G1 30°			20412798 21484834 3169366	<b>92-47032</b>	
	EX [2] 43,08 x 32.9 x 8,0	G1 45°				<b>92-47020</b>	
	EX [2] 43,08 x 32.9 x 8,0	G1 45°			1547583 21484834 3165369 3169366	<b>92-47027</b>	
	EX [1] 43,10 x 32.9 x 8,0	G1 45°				<b>92-47033</b>	
<b>148</b>		<b>131</b>					
<b>D 12 Euro 3</b>		<b>D-C MP, D-D MP, D-F MP</b>					
2006 →		D (LA)	6	12130 cm <sup>3</sup>	4V 478-570 kW (650-775 PS)	16,5:1 150,00 mm	
<b>D 12 Euro 2</b>		<b>D-E MG</b>					
2003 → 2006		D (LA)	6	12130 cm <sup>3</sup>	4V 310-370 kW (422-503 PS)	17,5:1 150,00 mm	
	IN [2] 40,0 x 8 x 191,9	S - Cr -		- 30° - VS -	9 - III	20459326 20463800	<b>48327</b>
	EX [2] 40,0 x 8 x 191,7	RA/S- Cr -		- 45° -	9 - III	20441486 3165234 8148574	<b>48227</b>
	[50] Ø 8 mm					1677875	<b>RK-8H</b>
	IN/EX [6] 15,00 x 8.01 x 83,4	G2			1546437 20817645 20817648 20904074 20905400 20919484 3165303 3183283	<b>81-47119</b>	
	IN/EX [6] 15,00 x 8.02 x 83,2	G2			1546437 20817645 20817648 20904074 20905400 20919484 3165303 3183283	<b>81-47114</b>	

Fortsetzung nächste Seite / continued on next page / suite page suivante / continuación página próxima / Продолжение на следующей странице

					Reference	Item No.
IN [2]	43,10 x 32 x 7,2	G1 30°			20459329 20482579 21484829	<b>92-47019</b>
IN [1]	43,05 x 32 x 7,2	G1 30°				<b>92-47032</b>
EX [2]	43,08 x 32.9 x 8,0	G1 45°			20412798 21484834 3169366	<b>92-47020</b>
EX [1]	43,10 x 32.9 x 8,0	G1 45°				<b>92-47033</b>

## 149 131

<b>TAD 1250 Euro 3</b>	<b>VE</b> 2005 →	D (LA)	6	12130 cm <sup>3</sup>	2V	259 kW	(352 PS)	18,1:1	150,00 mm
<b>TAD 1251 Euro 3</b>	<b>VE</b> 2005 →	D (LA)	6	12130 cm <sup>3</sup>	2V	289 kW	(393 PS)	18,1:1	150,00 mm
<b>TAD 1252 Euro 3</b>	<b>VE</b> 2005 →	D (LA)	6	12130 cm <sup>3</sup>	2V	313 kW	(426 PS)	18,1:1	150,00 mm

IN/EX [6]	15,00 x 8.02 x 83,2	G2				1546437 20817645 20817648 20904074 20905400 20919484 3165303 3183283	<b>81-47114</b>
IN [2]	43,10 x 32 x 7,2	G1 30°				20459329 20482579 21484829	<b>92-47019</b>
IN [1]	43,05 x 32 x 7,2	G1 30°					<b>92-47032</b>
EX [2]	43,08 x 32.9 x 8,0	G1 45°				20412798 21484834 3169366	<b>92-47020</b>
EX [1]	43,10 x 32.9 x 8,0	G1 45°					<b>92-47033</b>
						20576909	<b>20 1004 12009</b>

## 150 131

<b>D 13</b>	<b>C 460 EURO5</b>	D (LA)	6	12800 cm <sup>3</sup>	4V	338 kW	(460 PS)	17,8:1	158,00 mm
<b>D13C460 Euro 5</b>	09.2005 →	D (LA)	6	12777 cm <sup>3</sup>	4V	338-343 kW	(460-466 PS)	18,1:1	158,00 mm

41 980 6..

IN [2]	42,0 x 8 x 192,0	RA/S- Cr -	- 24.5°- VS -	22 - III	20561995 20712128 20740798 21428655	<b>48315</b>
EX [2]	40,0 x 8 x 191,7	NB/S- Cr -	- 39.5°- VS -	22 - III	20768519 21016539	<b>48316</b>
[50]	Ø 8 mm				20510747 419643	<b>MK-8H</b>

Fortsetzung nächste Seite / continued on next page / suite page suivante / continuación página próxima / Продолжение на следующей странице



					Reference	Item No.
	IN/EX [6] 15,00 x 8.01 x 83,4	G2			1546437 20817645 20817648 20904074 20905400 20919484 3165303 3183283	<b>81-47119</b>
	IN/EX [6] 15,00 x 8.02 x 83,2	G2			1546437 20817645 20817648 20904074 20905400 20919484 3165303 3183283	<b>81-47114</b>
	IN [1] 45,05 x 34 x 7,5	G1 24.5°			06-0461 20561997 20740804	<b>92-47028</b> <small>NEW</small>
	IN [1] 45,10 x 34 x 7,5	G1 24°				<b>92-47034</b>
	EX [1] 43,05 x 33 x 7,5	G1 39.5°			20530103 20541405	<b>92-47029</b> <small>NEW</small>
	EX [1] 43,10 x 33 x 7,5	G1 30°				<b>92-47035</b>
					20757636 21110845 22431885 22584601 21110437 22431881 22584597 20915925 20920956 22431882 21378520 22431879 22584596 23289160	<b>20 1004 13002</b> (1)  <b>20 1004 13005</b> (2)  <b>20 1004 13006</b> (3)  <b>20 1004 13009</b> (4)
	<p>(1) EBR-EPGC Motorbremsentyp/engine brake type/type de frein moteur/tipo de freno del motor/Тип моторного тормоза</p> <p>(2) EBR-VEB (Motorbremsentyp - Volvo Motorbremse einschließlich Auspuffdrucklager) EBR-EPGC (Motorbremsentyp - Auspuffdruckregler mit VCB (Volvo Kompressionsbremse) EBR-VEB - (engine brake type - Volvo engine brake including exhaust thrust bearing EPGC - (engine brake type - integrated pressure regulator with VCB (Volvo compression brake) EBR-VEB - (type de frein moteur - frein moteur Volvo avec butée d'embrayage) EPGC - (type de frein moteur - butée d'embrayage avec VCB (frein par compression Volvo)) EBR-VEB - (tipo de freno del motor: freno del motor Volvo incluido cojinete de empuje de gases de escape) EPGC - (tipo de freno del motor: regulador de empuje de gases de escape con VCB (freno de compresión Volvo) EBR-VEB (Тип моторного тормоза — моторный тормоз Volvo вместе с упорным подшипником системы выпуска) EPGC - (Тип моторного тормоза — регулятор давления системы выпуска с VCB (компрессионный тормоз Volvo)</p> <p>(3) Volvo: EGR-C, EBR-VEB7, EBR-VGTC / ohne Lager/without bearing/sans coussinet/sin cojinete/без подшипник</p> <p>(4) EBR-EPG Motorbremsentyp - Auspuffdrucklager/engine brake type - exhaust thrust bearing/type de frein moteur - butée d'embrayage/tipo de freno del motor: cojinete de empuje de gases de escape/ Тип моторного тормоза — упорный подшипник системы выпуска</p>					

					Reference	Item No.	
<b>151</b>		<b>131</b>					
<b>D 13</b>	<b>C 500 EURO5</b>						
		D (LA)	6	12800 cm <sup>3</sup>	4V	368 kW (500 PS) 17,8:1 158,00 mm	
<b>D13C500 Euro 5</b>	09.2005 →	D (LA)	6	12777 cm <sup>3</sup>	4V	368 kW (500 PS) 18,1:1 158,00 mm	
<b>D13C540 Euro 5</b>	09.2005 →	D (LA)	6	12777 cm <sup>3</sup>	4V	397 kW (540 PS) 18,1:1 158,00 mm	
41 980 6..							
	IN [2]	42,0 x 8 x 192,0	RA/S- Cr -	- 24.5°- VS -	22 - III	20561995 20712128 20740798 21428655 20768519 21016539	<b>48315</b>
	EX [2]	40,0 x 8 x 191,7	NB/S- Cr -	- 39.5°- VS -	22 - III		<b>48316</b>
	[50]	Ø 8 mm				20510747 419643	<b>MK-8H</b>
	IN/EX [6]	15,00 x 8.01 x 83,4	G2			1546437 20817645 20817648 20904074 20905400 20919484 3165303 3183283	<b>81-47119</b>
	IN/EX [6]	15,00 x 8.02 x 83,2	G2			1546437 20817645 20817648 20904074 20905400 20919484 3165303 3183283	<b>81-47114</b>
	IN [1]	45,05 x 34 x 7,5	G1 24.5°			06-0461 20561997 20740804	<b>92-47028</b> <small>NEW</small>
	IN [1]	45,10 x 34 x 7,5	G1 24°				<b>92-47034</b>
	EX [1]	43,05 x 33 x 7,5	G1 39.5°			20530103 20541405	<b>92-47029</b> <small>NEW</small>
	EX [1]	43,10 x 33 x 7,5	G1 30°				<b>92-47035</b>
						21110437 22431881 22584597 20915925 20920956 22431882 21378520 22431879 22584596 23289160	<b>20 1004 13005</b> (1)  <b>20 1004 13006</b> (2)  <b>20 1004 13009</b> (3)
Fortsetzung nächste Seite / continued on next page / suite page suivante / continuación página próxima / Продолжение на следующей странице							

					Reference	Item No.
(1)	EBR-VEB (Motorbremsentyp - Volvo Motorbremse einschließlich Auspuffdrucklager) EBR-EPGC (Motorbremsentyp - Auspuffdruckregler mit VCB (Volvo Kompressionsbremse)) EBR-VEB - (engine brake type - Volvo engine brake including exhaust thrust bearing) EPGC - (engine brake type - integrated pressure regulator with VCB (Volvo compression brake)) EBR-VEB - (type de frein moteur - frein moteur Volvo avec butée d'embrayage) EPGC - (type de frein moteur - butée d'embrayage avec VCB (frein par compression Volvo)) EBR-VEB - (tipo de freno del motor: freno del motor Volvo incluido cojinete de empuje de gases de escape) EPGC - (tipo de freno del motor: regulador de empuje de gases de escape con VCB (freno de compresión Volvo)) EBR-VEB (Тип моторного тормоза — моторный тормоз Volvo вместе с упорным подшипником системы выпуска) EPGC - (Тип моторного тормоза — регулятор давления системы выпуска с VCB (компрессионный тормоз Volvo))					
(2)	Volvo: EGR-C, EBR-VEB7, EBR-VGTC / ohne Lager/without bearing/sans coussinet/sin cojinete/без подшипник					
(3)	EBR-EPG Motorbremsentyp - Auspuffdrucklager/engine brake type - exhaust thrust bearing/type de frein moteur - butée d'embrayage/tipo de freno del motor: cojinete de empuje de gases de escape/ Тип моторного тормоза — упорный подшипник системы выпуска					

## 152 131

<b>D13A360 Euro 5</b>	11.2005 →	D (LA)	6	12777 cm <sup>3</sup>	4V	264 kW	(360 PS)	18,1:1	158,00 mm
<b>D13A440 Euro 5</b>	09.2005 →	D (LA)	6	12777 cm <sup>3</sup>	4V	324 kW	(440 PS)	18,1:1	158,00 mm
<b>D13A480 Euro 5</b>	09.2005 →	D (LA)	6	12777 cm <sup>3</sup>	4V	353 kW	(480 PS)	18,1:1	158,00 mm
<b>D13A520 Euro 5</b>	09.2005 →	D (LA)	6	12777 cm <sup>3</sup>	4V	382 kW	(520 PS)	18,1:1	158,00 mm

40 834 6.., 41 088 6..

	IN [2]	42,0 x 8 x 192,0	RA/S- Cr -	- 24.5°- VS -	22 - III	20561995 20712128 20740798 21428655	<b>48315</b>
	EX [2]	40,0 x 8 x 191,7	NB/S- Cr -	- 39.5°- VS -	22 - III	20768519 21016539	<b>48316</b>
	[50]	Ø 8 mm				20510747 419643	<b>MK-8H</b>
	IN/EX [6]	15,00 x 8.01 x 83,4	G2			1546437 20817645 20817648 20904074 20905400 20919484 3165303 3183283	<b>81-47119</b>
	IN/EX [6]	15,00 x 8.02 x 83,2	G2			1546437 20817645 20817648 20904074 20905400 20919484 3165303 3183283	<b>81-47114</b>
	IN [1]	45,05 x 34 x 7,5	G1 24.5°			06-0461 20561997 20740804	<b>92-47028</b> <small>NEW</small>
	IN [1]	45,10 x 34 x 7,5	G1 24°				<b>92-47034</b>
	EX [1]	43,05 x 33 x 7,5	G1 39.5°			20530103 20541405	<b>92-47029</b> <small>NEW</small>
	EX [1]	43,10 x 33 x 7,5	G1 30°				<b>92-47035</b>
						20742610 22431886 22584602	<b>20 1004 13000</b> <small>NEW</small>

					Reference	Item No.	
<b>153</b>		<b>131</b>	<b>D13A400 Euro 5</b> 09.2005 →    D (LA) 6 12777 cm <sup>3</sup> 4V    294 kW    (400 PS) 18,1:1 158,00 mm 40 834 6.., 41 088 6..				
	IN [2]	42,0 x 8 x 192,0	RA/S- Cr -	- 24.5°- VS -	22 - III	20561995 20712128 20740798 21428655	<b>48315</b>
	EX [2]	40,0 x 8 x 191,7	NB/S- Cr -	- 39.5°- VS -	22 - III	20768519 21016539	<b>48316</b>
	[50]	∅ 8 mm				20510747 419643	<b>MK-8H</b>
	IN/EX [6]	15,00 x 8.01 x 83,4	G2			1546437 20817645 20817648 20904074 20905400 20919484 3165303 3183283	<b>81-47119</b>
	IN/EX [6]	15,00 x 8.02 x 83,2	G2			1546437 20817645 20817648 20904074 20905400 20919484 3165303 3183283	<b>81-47114</b>
	IN [1]	45,05 x 34 x 7,5	G1 24.5°			06-0461 20561997 20740804	<b>92-47028</b> <small>NEW</small>
	IN [1]	45,10 x 34 x 7,5	G1 24°				<b>92-47034</b>
	EX [1]	43,05 x 33 x 7,5	G1 39.5°			20530103 20541405	<b>92-47029</b> <small>NEW</small>
	EX [1]	43,10 x 33 x 7,5	G1 30°				<b>92-47035</b>
						20742610 22431886 22584602 21198713	<b>20 1004 13000</b> <small>NEW</small>
							<b>20 1004 13007</b> (1)
							(1) EBR-VEB7 Motorbremsentyp - Volvo Motorbremse einschließlich Auspuffdrucklager/engine brake type - Volvo engine brake including exhaust thrust bearing/type de frein moteur - frein moteur Volvo avec butée d'embrayage/Tipo de freno del motor: freno del motor Volvo incluido cojinete de empuje de gases de escape/Тип моторного тормоза — моторный тормоз Volvo вместе с упорным подшипником системы выпуска
<b>154</b>		<b>131</b>	<b>D13A420</b> 09.2005 →    D (LA) 6 12777 cm <sup>3</sup> 4V    309 kW    (420 PS) 18,1:1 158,00 mm <b>D13A460</b> 09.2005 →    D (LA) 6 12777 cm <sup>3</sup> 4V    338 kW    (460 PS) 18,1:1 158,00 mm <b>D13A500 Euro 4/5</b> 01.2012 →    D (LA) 6 12777 cm <sup>3</sup> 4V    368 kW    (500 PS)    158,00 mm				
	IN [2]	42,0 x 8 x 192,0	RA/S- Cr -	- 24.5°- VS -	22 - III	20561995 20712128 20740798 21428655	<b>48315</b>
	EX [2]	40,0 x 8 x 191,7	NB/S- Cr -	- 39.5°- VS -	22 - III	20768519 21016539	<b>48316</b>
	[50]	∅ 8 mm				20510747 419643	<b>MK-8H</b>

V

					Reference	Item No.	
<b>155</b>		<b>131</b>	<b>D13B360 Euro 4/5</b> D (LA) 6 12777 cm <sup>3</sup> 4V 264 kW (360 PS) 18,1:1 158,00 mm <b>D13B400 Euro 4/5</b> 09.2005 → D (LA) 6 12777 cm <sup>3</sup> 4V 294 kW (400 PS) 18,1:1 158,00 mm <b>D13B440 Euro 4/5</b> 09.2005 → D (LA) 6 12777 cm <sup>3</sup> 4V 324 kW (440 PS) 18,1:1 158,00 mm <b>D13B500 Euro 4/5</b> 09.2005 → D (LA) 6 12777 cm <sup>3</sup> 4V 368 kW (500 PS) 18,1:1 158,00 mm 41 981 6..				
	IN [2]	42,0 x 8 x 192,0	RA/S- Cr -	- 24.5°- VS -	22 - III	20561995 20712128 20740798 21428655	<b>48315</b>
	EX [2]	40,0 x 8 x 191,7	NB/S- Cr -	- 39.5°- VS -	22 - III	20768519 21016539	<b>48316</b>
	[50]	∅ 8 mm				20510747 419643	<b>MK-8H</b>
	IN/EX [6]	15,00 x 8.01 x 83,4	G2			1546437 20817645 20817648 20904074 20905400 20919484 3165303 3183283	<b>81-47119</b>
	IN/EX [6]	15,00 x 8.02 x 83,2	G2			1546437 20817645 20817648 20904074 20905400 20919484 3165303 3183283	<b>81-47114</b>
	IN [1]	45,05 x 34 x 7,5	G1 24.5°			06-0461 20561997 20740804	<b>92-47028</b> <small>NEW</small>
	IN [1]	45,10 x 34 x 7,5	G1 24°				<b>92-47034</b>
	EX [1]	43,05 x 33 x 7,5	G1 39.5°			20530103 20541405	<b>92-47029</b> <small>NEW</small>
	EX [1]	43,10 x 33 x 7,5	G1 30°				<b>92-47035</b>
<b>156</b>		<b>131</b>	<b>D13K420 Euro 6</b> 09.2005 → D (LA) 6 12777 cm <sup>3</sup> 4V 309 kW (420 PS) 17,0:1 158,00 mm <b>D13K460 Euro 6</b> 09.2005 → D (LA) 6 12777 cm <sup>3</sup> 4V 338 kW (460 PS) 17,0:1 158,00 mm				
	IN [2]	42,0 x 8 x 192,0	RA/S- Cr -	- 24.5°- VS -	22 - III	20561995 20712128 20740798 21428655	<b>48315</b>
	EX [2]	40,0 x 8 x 191,7	ID/S - Cr -	- 35° -	22 - III	21428679	<b>48337</b> <small>NEW</small>
	[50]	∅ 8 mm				20510747 419643	<b>MK-8H</b>
	(1)	Volvo information: EML-BAS,Turbo-S,EBR-VEB+, EBR-EPGC				21698059 22431876 23289202	<b>20 1004 13008</b> (1)

V

					Reference	Item No.	
<b>157</b>		<b>131</b>					
<b>D 13</b>	<b>C 380 EURO5, C 420 EURO5</b>						
<b>D13C380 Euro 5</b>		D (LA)	6	12800 cm <sup>3</sup> 4V	280-309 kW (380-420 PS)	17,8:1 158,00 mm	
	01.2009 →	D (LA)	6	12777 cm <sup>3</sup> 4V	280-285 kW (380-388 PS)	18,1:1 158,00 mm	
<b>D13C420 Euro 5</b>		D (LA)	6	12777 cm <sup>3</sup> 4V	309 kW (420 PS)	18,1:1 158,00 mm	
	01.2007 →	D (LA)	6	12777 cm <sup>3</sup> 4V	309 kW (420 PS)	18,1:1 158,00 mm	
41 980 6..							
	IN [2]	42,0 x 8 x 192,0	RA/S- Cr -	- 24.5°- VS -	22 - III	20561995 20712128 20740798 21428655 20768519 21016539	<b>48315</b>
	EX [2]	40,0 x 8 x 191,7	NB/S- Cr -	- 39.5°- VS -	22 - III	20768519 21016539	<b>48316</b>
	[50]	∅ 8 mm				20510747 419643	<b>MK-8H</b>
	IN/EX [6]	15,00 x 8.01 x 83,4	G2			1546437 20817645 20817648 20904074 20905400 20919484 3165303 3183283	<b>81-47119</b>
	IN/EX [6]	15,00 x 8.02 x 83,2	G2			1546437 20817645 20817648 20904074 20905400 20919484 3165303 3183283	<b>81-47114</b>
	IN [1]	45,05 x 34 x 7,5	G1 24.5°			06-0461 20561997 20740804	<b>92-47028</b> <small>NEW</small>
	IN [1]	45,10 x 34 x 7,5	G1 24°				<b>92-47034</b>
	EX [1]	43,05 x 33 x 7,5	G1 39.5°			20530103 20541405	<b>92-47029</b> <small>NEW</small>
	EX [1]	43,10 x 33 x 7,5	G1 30°				<b>92-47035</b>
						21110842 22431883 22584599 20757636 21110845 22431885 22584601 20915925 20920956 22431882	<b>20 1004 13001</b> (1)  <b>20 1004 13002</b> (2)  <b>20 1004 13006</b> (3)
	<p>(1) Motorbremsentyp/engine brake type/type de freine de moteur/Тип моторного тормоза</p> <p>(2) EBR-EPGC Motorbremsentyp/engine brake type/type de frein moteur/tipo de freno del motor/Тип моторного тормоза</p> <p>(3) Volvo: EGR-C, EBR-VEB7, EBR-VGTC / ohne Lager/without bearing/sans coussinet/sin cojinete/без подшипник</p>						

V



					Reference	Item No.	
<b>158</b>		<b>131</b>					
<b>TAD1340VE Euro 2</b>	01.2009 →	D (LA) 6	12777 cm <sup>3</sup> 4V	240-256 kW (326-348 PS)	18,1:1	158,00 mm	
<b>TAD1341GE Euro 2</b>	01.2009 →	D (LA) 6	12777 cm <sup>3</sup> 4V	275-324 kW (374-441 PS)	18,1:1	158,00 mm	
<b>TAD1341VE Euro 2</b>	01.2009 →	D (LA) 6	12777 cm <sup>3</sup> 4V	259-275 kW (352-374 PS)	18,1:1	158,00 mm	
<b>TAD1342GE Euro 2</b>	01.2009 →	D (LA) 6	12777 cm <sup>3</sup> 4V	303-377 kW (412-513 PS)	18,1:1	158,00 mm	
<b>TAD1342VE Euro 2</b>	01.2009 →	D (LA) 6	12777 cm <sup>3</sup> 4V	294-310 kW (400-421 PS)	18,1:1	158,00 mm	
<b>TAD1343GE Euro 2</b>	01.2009 →	D (LA) 6	12777 cm <sup>3</sup> 4V	325-388 kW (442-528 PS)	18,1:1	158,00 mm	
<b>TAD1344GE Euro 2</b>	01.2009 →	D (LA) 6	12777 cm <sup>3</sup> 4V	354-431 kW (481-586 PS)	18,1:1	158,00 mm	
<b>TAD1344VE Euro 2</b>	01.2009 →	D (LA) 6	12777 cm <sup>3</sup> 4V	336-352 kW (457-479 PS)	18,1:1	158,00 mm	
<b>TAD1345GE Euro 2</b>	01.2009 →	D (LA) 6	12777 cm <sup>3</sup> 4V	388-431 kW (528-586 PS)	18,1:1	158,00 mm	
<b>TAD1345VE Euro 2</b>	01.2009 →	D (LA) 6	12777 cm <sup>3</sup> 4V	377-394 kW (513-536 PS)	18,1:1	158,00 mm	
<b>TAD1350GE Euro 3</b>	2008 →	D (LA) 6	12777 cm <sup>3</sup> 4V	245-269 kW (333-366 PS)	18,1:1	158,00 mm	
<b>TAD1350VE Euro 2</b>	01.2008 →	D (LA) 6	12777 cm <sup>3</sup> 4V	256 kW (348 PS)	18,1:1	158,00 mm	
<b>TAD1351GE Euro 3</b>	2008 →	D (LA) 6	12777 cm <sup>3</sup> 4V	279-323 kW (379-439 PS)	18,1:1	158,00 mm	
<b>TAD1352GE Euro 3</b>	2008 →	D (LA) 6	12777 cm <sup>3</sup> 4V	314-376 kW (427-511 PS)	18,1:1	158,00 mm	
<b>TAD1352VE Euro 2</b>		D (LA) 6	12777 cm <sup>3</sup> 4V	315 kW (428 PS)	17,8:1	158,00 mm	
<b>TAD1353GE Euro 3</b>	2008 →	D (LA) 6	12777 cm <sup>3</sup> 4V	391-430 kW (532-585 PS)	18,1:1	158,00 mm	
<b>TAD1354GE Euro 3</b>	01.2008 →	D (LA) 6	12777 cm <sup>3</sup> 4V	328-376 kW (446-511 PS)	18,1:1	158,00 mm	
<b>TAD1355GE Euro 3</b>	01.2008 →	D (LA) 6	12777 cm <sup>3</sup> 4V	344-390 kW (468-530 PS)	18,1:1	158,00 mm	
<b>TAD1360VE</b>	01.2010 →	D (LA) 6	12777 cm <sup>3</sup> 4V	256 kW (348 PS)	18,1:1	158,00 mm	
<b>TAD1361VE</b>	01.2010 →	D (LA) 6	12777 cm <sup>3</sup> 4V	285 kW (387 PS)	18,1:1	158,00 mm	
<b>TAD1362VE</b>	01.2010 →	D (LA) 6	12777 cm <sup>3</sup> 4V	315 kW (428 PS)	18,1:1	158,00 mm	
<b>TAD1363VE</b>	01.2010 →	D (LA) 6	12777 cm <sup>3</sup> 4V	345 kW (469 PS)	18,1:1	158,00 mm	
<b>TAD1364VE</b>	01.2010 →	D (LA) 6	12777 cm <sup>3</sup> 4V	375 kW (510 PS)	18,1:1	158,00 mm	
<b>TAD1365VE</b>	01.2010 →	D (LA) 6	12777 cm <sup>3</sup> 4V	405 kW (551 PS)	18,1:1	158,00 mm	
40 834 6.., 41 980 6..							
	IN [2]	42,0 x 8 x 192,0	RA/S- Cr -	- 24.5°- VS -	22 - III	20561995 20712128 20740798 21428655	<b>48315</b>
	EX [2]	40,0 x 8 x 191,7	NB/S- Cr -	- 39.5°- VS -	22 - III	20768519 21016539	<b>48316</b>
	[50]	Ø 8 mm				20510747 419643	<b>MK-8H</b>
	IN/EX [6]	15,00 x 8.01 x 83,4	G2			1546437 20817645 20817648 20904074 20905400 20919484 3165303 3183283	<b>81-47119</b>
	IN/EX [6]	15,00 x 8.02 x 83,2	G2			1546437 20817645 20817648 20904074 20905400 20919484 3165303 3183283	<b>81-47114</b>
						21154172	<b>20 1004 13100</b>

V

					Reference	Item No.		
<b>159</b>		<b>131</b>						
<b>D13B-A MP</b>	01.2009 →	D (LA)	6	12800 cm <sup>3</sup>	4V	661 kW (900 PS)	16,5:1	158,00 mm
<b>D13B-B MP</b>	01.2009 →	D (LA)	6	12800 cm <sup>3</sup>	4V	588 kW (800 PS)	16,7:1	158,00 mm
<b>D13B-C MP</b>	01.2009 →	D (LA)	6	12800 cm <sup>3</sup>	4V	558 kW (800 PS)	16,5:1	158,00 mm
<b>D13B-D MP</b>	01.2009 →	D (LA)	6	12800 cm <sup>3</sup>	4V	515 kW (700 PS)	16,7:1	158,00 mm
<b>D13B-G MP</b>	01.2009 →	D (LA)	6	12800 cm <sup>3</sup>	4V	588-661 kW (800-900 PS)	16,5:1	158,00 mm
<b>D13B-H MP</b>	01.2009 →	D (LA)	6	12800 cm <sup>3</sup>	4V	661 kW (900 PS)	16,5:1	158,00 mm
<b>D13B-J MP</b>	01.2009 →	D (LA)	6	12800 cm <sup>3</sup>	4V	661 kW (900 PS)	16,5:1	158,00 mm
<b>D13B-K MP</b>	01.2009 →	D (LA)	6	12800 cm <sup>3</sup>	4V	588 kW (800 PS)	16,5:1	158,00 mm
<b>D13B-L MP</b>	01.2009 →	D (LA)	6	12800 cm <sup>3</sup>	4V	588 kW (800 PS)	16,5:1	158,00 mm
<b>D13B-M MP</b>	01.2009 →	D (LA)	6	12800 cm <sup>3</sup>	4V	515 kW (700 PS)	16,7:1	158,00 mm
	[50]	∅ 8 mm				20510747 419643	<b>MK-8H</b>	
	IN/EX [6]	15,00 x 8.01 x 83,4	G2			1546437 20817645 20817648 20904074 20905400 20919484 3165303 3183283	<b>81-47119</b>	
	IN/EX [6]	15,00 x 8.02 x 83,2	G2			1546437 20817645 20817648 20904074 20905400 20919484 3165303 3183283	<b>81-47114</b>	
	IN [1]	45,05 x 34 x 7,5	G1 24.5°			06-0461 20561997 20740804	<b>92-47028</b> <small>NEW</small>	
	EX [1]	43,05 x 33 x 7,5	G1 39.5°			20530103 20541405	<b>92-47029</b> <small>NEW</small>	
<b>160</b>		<b>131</b>						
<b>TAD1343VE Euro 2</b>	01.2009 →	D (LA)	6	12777 cm <sup>3</sup>	4V	316-332 kW (430-451 PS)	18,1:1	158,00 mm
40 834 6..								
	IN/EX [6]	15,00 x 8.01 x 83,4	G2			1546437 20817645 20817648 20904074 20905400 20919484 3165303 3183283	<b>81-47119</b>	
	IN/EX [6]	15,00 x 8.02 x 83,2	G2			1546437 20817645 20817648 20904074 20905400 20919484 3165303 3183283	<b>81-47114</b>	
						21154172	<b>20 1004 13100</b>	

V

					Reference	Item No.		
<b>161</b>		<b>131</b>						
<b>D13B-E MG</b>	01.2011 →	D (LA)	6	12800 cm <sup>3</sup>	4V	300-400 kW (408-544 PS)	16,7:1	158,00 mm
<b>D13B-F MG</b>	01.2011 →	D (LA)	6	12800 cm <sup>3</sup>	4V	358-400 kW (487-544 PS)	16,7:1	158,00 mm
<b>D13C1-A MH</b>		D (A)	6	12800 cm <sup>3</sup>	4V			158,00 mm
<b>D13C2-A MH</b>		D (A)	6	12800 cm <sup>3</sup>	4V			158,00 mm
40 834 6.., 41 980 6..								
	[50]	∅ 8 mm				20510747 419643		<b>MK-8H</b>
	IN/EX [6]	15,00 x 8.01 x 83,4	G2			1546437 20817645 20817648 20904074 20905400 20919484 3165303 3183283		<b>81-47119</b>
	IN/EX [6]	15,00 x 8.02 x 83,2	G2			1546437 20817645 20817648 20904074 20905400 20919484 3165303 3183283		<b>81-47114</b>
	IN [1]	45,05 x 34 x 7,5	G1 24.5°			06-0461 20561997 20740804		<b>92-47028</b> <small>NEW</small>
	EX [1]	43,05 x 33 x 7,5	G1 39.5°			20530103 20541405		<b>92-47029</b> <small>NEW</small>
						21154172		<b>20 1004 13100</b>
	EX [1]					20381702 20738748 21023450 21089229 21504759 21881195 20738736 21024789		<b>20 1004 12101</b>
	[2]							<b>20 1004 12102</b> (1)
	(1)	Injector						
<b>162</b>		<b>131</b>						
<b>D13K500 Euro 6</b>	01.2012 →	D (LA)	6	12777 cm <sup>3</sup>	4V	368 kW (500 PS)	17,0:1	158,00 mm
<b>D13K540 Euro 6</b>	01.2012 →	D (LA)	6	12777 cm <sup>3</sup>	4V	397 kW (540 PS)	17,0:1	158,00 mm
	IN [2]	42,0 x 8 x 192,0	RA/S- Cr -	- 24.5° -	VS -	22 - III	20561995 20712128 20740798 21428655	<b>48315</b>
	EX [2]	40,0 x 8 x 191,7	ID/S - Cr -	- 35° -	-	22 - III	21428679	<b>48337</b> <small>NEW</small>
	[50]	∅ 8 mm				20510747 419643		<b>MK-8H</b>
						22486978 23289181		<b>20 1004 13010</b>
<b>163</b>		<b>131</b>						
<b>D 13</b>	<b>C 540 EURO5</b>	D (LA)	6	12800 cm <sup>3</sup>	4V	397 kW (540 PS)		158,00 mm
41 980 6..								
Fortsetzung nächste Seite / continued on next page / suite page suivante / continuación página próxima / Продолжение на следующей странице								

V

					Reference	Item No.	
					21110437	<b>20 1004 13005</b> (1)	
					22431881		
					22584597		
					20915925	<b>20 1004 13006</b> (2)	
					20920956		
					22431882		
					21378520	<b>20 1004 13009</b> (3)	
					22431879		
					22584596		
					23289160		
	(1)	EBR-VEB (Motorbremsentyp - Volvo Motorbremse einschließlich Auspuffdrucklager) EBR-EPGC (Motorbremsentyp - Auspuffdruckregler mit VCB (Volvo Kompressionsbremse) EBR-VEB - (engine brake type - Volvo engine brake including exhaust thrust bearing EPGC - (engine brake type - integrated pressure regulator with VCB (Volvo compression brake) EBR-VEB - (type de frein moteur - frein moteur Volvo avec butée d'embrayage) EPGC - (type de frein moteur - butée d'embrayage avec VCB (frein par compression Volvo)) EBR-VEB - (tipo de freno del motor: freno del motor Volvo incluido cojinete de empuje de gases de escape) EPGC - (tipo de freno del motor: regulador de empuje de gases de escape con VCB (freno de compresión Volvo) EBR-VEB (Тип моторного тормоза — моторный тормоз Volvo вместе с упорным подшипником системы выпуска) EPGC - (Тип моторного тормоза — регулятор давления системы выпуска с VCB (компрессионный тормоз Volvo)					
	(2)	Volvo: EGR-C, EBR-VEB7, EBR-VGTC / ohne Lager/without bearing/sans coussinet/sin cojinete/без подшипник					
(3)	EBR-EPG Motorbremsentyp - Auspuffdrucklager/engine brake type - exhaust thrust bearing/type de frein moteur - butée d'embrayage/tipo de freno del motor: cojinete de empuje de gases de escape/Тип моторного тормоза — упорный подшипник системы выпуска						

## 164 131

<b>D13 375</b>	D (A)	6	12777 cm <sup>3</sup>	4V	276 kW	(375 PS)	17:1	158,00 mm
<b>D13 405</b>	D (A)	6	12777 cm <sup>3</sup>	4V	298 kW	(405 PS)	17:1	158,00 mm
<b>D13 425</b>	D (A)	6	12777 cm <sup>3</sup>	4V	313 kW	(425 PS)	17:1	158,00 mm
<b>D13 435</b>	D (A)	6	12777 cm <sup>3</sup>	4V	320 kW	(435 PS)	17:1	158,00 mm
<b>D13 455</b>	D (A)	6	12777 cm <sup>3</sup>	4V	335 kW	(455 PS)	17:1	158,00 mm
<b>D13 500</b>	D (A)	6	12777 cm <sup>3</sup>	4V	368 kW	(500 PS)	17:1	158,00 mm

	1058,5 mm				20758404	<b>20 1004 13003</b> (1)
					22431887	
					22584603	
					20742607	<b>20 1004 13004</b> (2)
					22258001	
					22431875	
(1)	ohne Lager/without bearing/sans coussinet/sin cojinete/без подшипник / EBR-EPG Motorbremsentyp - Auspuffdrucklager/engine brake type - exhaust thrust bearing/type de frein moteur - butée d'embrayage/tipo de freno del motor: cojinete de empuje de gases de escape/Тип моторного тормоза — упорный подшипник системы выпуска					
(2)	EBR-VEB7 Motorbremsentyp - Volvo Motorbremse einschließlich Auspuffdrucklager/engine brake type - Volvo engine brake including exhaust thrust bearing/type de frein moteur - frein moteur Volvo avec butée d'embrayage/Типо de freno del motor: freno del motor Volvo incluido cojinete de empuje de gases de escape/Тип моторного тормоза — моторный тормоз Volvo вместе с упорным подшипником системы выпуска					

## 165 131

<b>D13B-E MG</b>	(FE)							
		D (LA)	6	12800 cm <sup>3</sup>	4V	300 kW	(408 PS)	16,7:1 158,00 mm
<b>D13B-F MG</b>	(FE)							
		D (LA)	6	12800 cm <sup>3</sup>	4V	358 kW	(487 PS)	16,7:1 158,00 mm

Fortsetzung nächste Seite / continued on next page / suite page suivante / continuación página próxima / Продолжение на следующей странице

					Reference	Item No.
	IN/EX [6] 15,00 x 8.01 x 83,4	G2			1546437 20817645 20817648 20904074 20905400 20919484 3165303 3183283	81-47119

## 166 131

D13B-E MH	D (LA) 6	12800 cm <sup>3</sup>	4V	294-441 kW	(400-600 PS)	16,7:1	158,00 mm
D13B-N MH	D (LA) 6	12800 cm <sup>3</sup>	4V	294-441 kW	(400-600 PS)	16,7:1	158,00 mm

40 834 6..

	[50] Ø 8 mm				20510747 419643	MK-8H
	IN/EX [6] 15,00 x 8.01 x 83,4	G2			1546437 20817645 20817648 20904074 20905400 20919484 3165303 3183283	81-47119
	IN/EX [6] 15,00 x 8.02 x 83,2	G2			1546437 20817645 20817648 20904074 20905400 20919484 3165303 3183283	81-47114
	IN [1] 45,05 x 34 x 7,5	G1 24.5°			06-0461 20561997 20740804	92-47028 <b>NEW</b>
	EX [1] 43,05 x 33 x 7,5	G1 39.5°			20530103 20541405	92-47029 <b>NEW</b>
					21154172	20 1004 13100

## 167 131

D13C1-A MG	D (A) 6	12800 cm <sup>3</sup>	4V			158,00 mm
D13C2-A MG	D (A) 6	12800 cm <sup>3</sup>	4V			158,00 mm

40 834 6.., 41 980 6..

	[50] Ø 8 mm				20510747 419643	MK-8H
	IN/EX [6] 15,00 x 8.01 x 83,4	G2			1546437 20817645 20817648 20904074 20905400 20919484 3165303 3183283	81-47119
	IN [1] 45,05 x 34 x 7,5	G1 24.5°			06-0461 20561997 20740804	92-47028 <b>NEW</b>
	EX [1] 43,05 x 33 x 7,5	G1 39.5°			20530103 20541405	92-47029 <b>NEW</b>

Fortsetzung nächste Seite / continued on next page / suite page suivante / continuación página próxima / Продолжение на следующей странице

					Reference	Item No.
					21154172	20 1004 13100
EX [1]					20381702 20738748 21023450 21089229 21504759 21881195	20 1004 12101
[2]					20738736 21024789	20 1004 12102 (1)
(1) Injector						

## 168

## 131

D13C1-A MP

D (A) 6 12800 cm<sup>3</sup> 4V

158,00 mm

D13C2-A MP

D (A) 6 12800 cm<sup>3</sup> 4V

158,00 mm

41 980 6..

[50]	Ø 8 mm				20510747 419643	MK-8H
IN/EX [6]	15,00 x 8.01 x 83,4	G2			1546437 20817645 20817648 20904074 20905400 20919484 3165303 3183283	81-47119
IN/EX [6]	15,00 x 8.02 x 83,2	G2			1546437 20817645 20817648 20904074 20905400 20919484 3165303 3183283	81-47114
IN [1]	45,05 x 34 x 7,5	G1 24.5°			06-0461 20561997 20740804	92-47028 <b>NEW</b>
EX [1]	43,05 x 33 x 7,5	G1 39.5°			20530103 20541405	92-47029 <b>NEW</b>
[2]					20738736 21024789	20 1004 12102 (1)
(1) Injector						

## 169

## 131

TAD 1344

GE-B

D (LA) 6 12780 cm<sup>3</sup> 2V

158,00 mm

TAD 1345

GE-B

D (LA) 6 12780 cm<sup>3</sup> 2V

158,00 mm

IN/EX [6]	15,00 x 8.01 x 83,4	G2			1546437 20817645 20817648 20904074 20905400 20919484 3165303 3183283	81-47119
					21154172	20 1004 13100



					Reference	Item No.	
<b>170</b>		<b>131</b>					
<b>TAD1351VE Euro 2</b>	D (LA)	6	12777 cm <sup>3</sup>	4V	285 kW	(387 PS) 17,8:1 158,00 mm	
<b>TAD1353VE Euro 2</b>	D (LA)	6	12777 cm <sup>3</sup>	4V	345 kW	(469 PS) 17,8:1 158,00 mm	
	IN [2]	42,0 x 8 x 192,0	RA/S- Cr -	- 24.5°- VS -	22 - III	20561995 20712128 20740798 21428655	<b>48315</b>
	EX [2]	40,0 x 8 x 191,7	NB/S- Cr -	- 39.5°- VS -	22 - III	20768519 21016539	<b>48316</b>
	[50]	Ø 8 mm				20510747 419643	<b>MK-8H</b>
	IN/EX [6]	15,00 x 8.02 x 83,2	G2			1546437 20817645 20817648 20904074 20905400 20919484 3165303 3183283	<b>81-47114</b>
						21154172	<b>20 1004 13100</b>
<b>171</b>		<b>131</b>					
<b>TAD1371VE Euro 4</b>	D (LA)	6	12777 cm <sup>3</sup>	4V	285 kW	(387 PS) 17,8:1 158,00 mm	
<b>TAD1372VE Euro 4</b>	D (LA)	6	12777 cm <sup>3</sup>	4V	315 kW	(428 PS) 17,8:1 158,00 mm	
<b>TAD1373VE Euro 4</b>	D (LA)	6	12777 cm <sup>3</sup>	4V	345 kW	(469 PS) 17,8:1 158,00 mm	
<b>TAD1374VE Euro 4</b>	D (LA)	6	12777 cm <sup>3</sup>	4V	375 kW	(510 PS) 17,8:1 158,00 mm	
41 980 6..							
	IN [2]	42,0 x 8 x 192,0	RA/S- Cr -	- 24.5°- VS -	22 - III	20561995 20712128 20740798 21428655	<b>48315</b>
	EX [2]	40,0 x 8 x 191,7	NB/S- Cr -	- 39.5°- VS -	22 - III	20768519 21016539	<b>48316</b>
	[50]	Ø 8 mm				20510747 419643	<b>MK-8H</b>
	IN/EX [6]	15,00 x 8.01 x 83,4	G2			1546437 20817645 20817648 20904074 20905400 20919484 3165303 3183283	<b>81-47119</b>
	IN/EX [6]	15,00 x 8.02 x 83,2	G2			1546437 20817645 20817648 20904074 20905400 20919484 3165303 3183283	<b>81-47114</b>
<b>172</b>		<b>131</b>					
<b>TAD1375VE Euro 4</b>	D (LA)	6	12777 cm <sup>3</sup>	4V	405 kW	(551 PS) 17,8:1 158,00 mm	
41 980 6..							
Fortsetzung nächste Seite / continued on next page / suite page suivante / continuación página próxima / Продолжение на следующей странице							

V

					Reference	Item No.
IN [2]	42,0 x 8 x 192,0	RA/S- Cr -	- 24.5°- VS -	22 - III	20561995 20712128 20740798 21428655	<b>48315</b>
EX [2]	40,0 x 8 x 191,7	NB/S- Cr -	- 39.5°- VS -	22 - III	20768519 21016539	<b>48316</b>
[50]	Ø 8 mm				20510747 419643	<b>MK-8H</b>
IN/EX [6]	15,00 x 8.02 x 83,2	G2			1546437 20817645 20817648 20904074 20905400 20919484 3165303 3183283	<b>81-47114</b>

## 173 144

<b>D 16 Euro 2</b>	<b>B 470</b>	08.1998 → 01.2003	D (LA)	6	16120 cm <sup>3</sup>	4V	346 kW	(470 PS)	17,5:1	165,00 mm
<b>D16A470 Euro 2</b>		08.1993 → 12.2002	D (LA)	6	16123 cm <sup>3</sup>	4V	346 kW	(470 PS)	17,5:1	165,00 mm
<b>D16A520 Euro 1</b>		08.1993 →	D (LA)	6	16123 cm <sup>3</sup>	4V	382 kW	(520 PS)	17,5:1	165,00 mm
<b>D16B520 Euro 2</b>		08.1993 →	D (LA)	6	16123 cm <sup>3</sup>	4V	382 kW	(520 PS)	17,5:1	165,00 mm
<b>TD 162 Euro 0</b>	<b>F</b>	01.1987 → 12.1995	D (LA)	6	16123 cm <sup>3</sup>	4V	330-357 kW	(450-485 PS)	15:1	165,00 mm
<b>TD 162</b>	<b>AG, FJ, FS</b>	01.1987 →	D (LA)	6		4V	217-405 kW	(295-551 PS)		165,00 mm
<b>TD 162</b>	<b>FL</b>	01.1987 → 12.1995	D (A)	6	16123 cm <sup>3</sup>	4V	330-357 kW	(450-485 PS)	16:1	165,00 mm
<b>TD 163 Euro 1</b>	<b>ES</b>	01.1987 → 12.1995	D (LA)	6	16123 cm <sup>3</sup>	4V	368 kW	(500 PS)	17,5:1	165,00 mm

40 610 6..., 99 365 6..

IN [2]	47,0 x 9,5 x 176,8	S - Cr -	- 30° -	9 - III	1543026 1556472 1556813	<b>48260</b>
EX [2]	45,0 x 9,5 x 176,9	RA/S- Cr -	- 45° - VS -	9 - III	1543027 1556473 1556896 863702	<b>48256</b>
[50]					1543078	<b>RK-9.5H</b>
IN [6]	16,00 x 9.53 x 82,0	G1			1556607 20355012	<b>81-47107</b>
EX [6]	16,00 x 9.53 x 71,0	G1			1556604 20355015	<b>81-47108</b>
[1]	M				1556947 975160	<b>20 1004 16001 (1)</b>
	(1) Rollenstößel/roller tappet/poussoir à galet/empujador de rodillos/роликовый толкатель					









					Reference	Item No.	
<b>174</b>		<b>144</b>					
<b>TAD 1630</b>	<b>PB</b>		D (LA) 6 16120 cm <sup>3</sup> 2V			165,00 mm	
<b>TAD1630GE Euro 1</b>			D (LA) 6 16120 cm <sup>3</sup> 4V	360-395 kW (490-537 PS)	15:1	165,00 mm	
<b>TAMD 162</b>	<b>C-C</b> 02.1995 → 1999 → 2001		D (LA) 6 16120 cm <sup>3</sup> 2V	375 kW (510 PS)	17:1	165,00 mm	
<b>TAMD 163</b>	<b>A-A, P-A</b> 1994 → 2001		D (LA) 6 16120 cm <sup>3</sup> 2V	404-566 kW (550-770 PS)	17:1	165,00 mm	
<b>TAMD 165</b>	<b>A-A, C-A</b> 11.2001 → 2005		D (LA) 6 16120 cm <sup>3</sup> 2V	375-404 kW (510-550 PS)	17:1	165,00 mm	
<b>TID 162</b>	<b>AG, AGP, AP, APB</b> 06.1987 →		D (LA) 6 16120 cm <sup>3</sup> 2V	217-405 kW (295-551 PS)		165,00 mm	
<b>TWD 1620</b>	<b>G</b> 11.1991 →		D (LA) 6 16120 cm <sup>3</sup> 2V	217-405 kW (295-551 PS)	15:1	165,00 mm	
<b>TWD 1630</b>	<b>PP</b>		D (LA) 6 16120 cm <sup>3</sup> 2V			165,00 mm	
40 810 6.., 99 365 6..							
	IN [1]	50,07 x 39.5 x 7,6	G1 30°			<b>92-47040</b>	
	EX [1]	48,04 x 37.5 x 12,4	G3 45°			<b>92-47041</b>	
<b>175</b>		<b>144</b>					
<b>TAD1630G</b>			D (LA) 6 16123 cm <sup>3</sup> 4V	395-474 kW (537-644 PS)	15:1	165,00 mm	
<b>TAD1630P</b>	02.1995 →		D (LA) 6 16123 cm <sup>3</sup> 4V	330-415 kW (449-564 PS)	15:1	165,00 mm	
<b>TAD1630V</b>			D (LA) 6 16123 cm <sup>3</sup> 4V	330-415 kW (449-564 PS)	15:1	165,00 mm	
<b>TAD1631G</b>			D (LA) 6 16123 cm <sup>3</sup> 4V	435-546 kW (591-742 PS)	15:1	165,00 mm	
<b>TAD1631GE</b>			D (LA) 6 16123 cm <sup>3</sup> 4V	435-546 kW (591-742 PS)	15:1	165,00 mm	
<b>TWD1630G</b>	10.1994 →		D (LA) 6 16123 cm <sup>3</sup> 4V	350-430 kW (476-585 PS)	15:1	165,00 mm	
<b>TWD1630P</b>	02.1995 →		D (LA) 6 16123 cm <sup>3</sup> 4V	288-383 kW (392-521 PS)	15:1	165,00 mm	
<b>TWD1630V</b>			D (LA) 6 16123 cm <sup>3</sup> 4V	288-383 kW (392-521 PS)	15:1	165,00 mm	
40 810 6..							
	IN [2]	47,0 x 9,5 x 176,8	S - Cr -	- 30° - -	9 - III	1543026 1556472 1556813	<b>48260</b>
	EX [2]	45,0 x 9,5 x 176,9	RA/S- Cr -	- 45° - VS -	9 - III	1543027 1556473 1556896 863702	<b>48256</b>
	[50]					1543078	<b>RK-9.5H</b>
	IN [1]	50,07 x 39.5 x 7,6	G1 30°				<b>92-47040</b>
	EX [1]	48,04 x 37.5 x 12,4	G3 45°				<b>92-47041</b>
<b>176</b>		<b>144</b>					
<b>TAMD 165</b>	<b>A, C, P, P-A</b> 11.2001 → 2005		D (LA) 6 16120 cm <sup>3</sup> 2V	375-552 kW (510-751 PS)	17:1	165,00 mm	
	IN [2]	43,10 x 32 x 7,2	G1 30°			20459329 20482579 21484829	<b>92-47019</b>
	IN [1]	43,05 x 32 x 7,2	G1 30°				<b>92-47032</b>
	IN [1]	50,07 x 39.5 x 7,6	G1 30°				<b>92-47040</b>
	EX [2]	43,08 x 32.9 x 8,0	G1 45°			20412798 21484834 3169366	<b>92-47020</b>
	EX [1]	43,10 x 32.9 x 8,0	G1 45°				<b>92-47033</b>
	EX [1]	48,04 x 37.5 x 12,4	G3 45°				<b>92-47041</b>

V

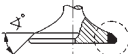
					Reference	Item No.	
<b>177</b>		<b>144</b>					
<b>D16C550 Euro 3</b>	01.2003 →	D (LA) 6	16123 cm <sup>3</sup> 4V	404 kW (549 PS)	18:1	165,00 mm	
<b>D16C610 Euro 3</b>	01.2003 →	D (LA) 6	16123 cm <sup>3</sup> 4V	449 kW (610 PS)	18:1	165,00 mm	
<b>D16E540 Euro 4</b>	01.2003 →	D (LA) 6	16123 cm <sup>3</sup> 4V	396 kW (540 PS)	17,3:1	165,00 mm	
<b>D16E580 Euro 4</b>	01.2005 →	D (LA) 6	16123 cm <sup>3</sup> 4V	426 kW (580 PS)	17,3:1	165,00 mm	
<b>D16E660 Euro 4</b>	01.2005 →	D (LA) 6	16123 cm <sup>3</sup> 4V	485 kW (660 PS)	17,3:1	165,00 mm	
<b>D16G540 Euro 5</b>	01.2005 →	D (LA) 6	16123 cm <sup>3</sup> 4V	396 kW (540 PS)	17,3:1	165,00 mm	
<b>D16G600 Euro 5</b>	01.2008 →	D (LA) 6	16123 cm <sup>3</sup> 4V	441 kW (600 PS)	17,3:1	165,00 mm	
<b>D16G700 Euro 5</b>	01.2009 →	D (LA) 6	16123 cm <sup>3</sup> 4V	515 kW (700 PS)	17,3:1	165,00 mm	
<b>D16G750 Euro 5</b>	01.2012 →	D (LA) 6	16123 cm <sup>3</sup> 4V	551-552 kW (749-751 PS)	17,3:1	165,00 mm	
	IN [2]	49,0 x 10 x 192,9	I/S - Cr -	- 25° - VS -	15 - III	20739057 20739058 24426433	<b>48319</b>
	IN [2]	49,0 x 10 x 192,9	RA/S- Cr -	- 20° -	15 - III	20735572 20735573	<b>48317</b>
	EX [2]	46,0 x 10 x 191,4	I/S - Cr -	- 45° - VS -	9 - III	20513284 20513285	<b>48330</b>
	[50]	Ø 10 mm				8170995	<b>RK-10H</b>
	IN/EX [6]	16,00 x 10 x 83,4	G2			20562837 20916916 21067953	<b>81-47120</b>
<b>178</b>		<b>144</b>					
<b>TAD1640GE Euro 2</b>	2004 →	D (LA) 6	16123 cm <sup>3</sup> 4V	393-480 kW (534-653 PS)	17,5:1	165,00 mm	
<b>TAD1640VE-B Euro 2</b>		D (LA) 6	16123 cm <sup>3</sup> 4V	405 kW (551 PS)	16,8:1	165,00 mm	
<b>TAD1641GE Euro 2</b>	2004 →	D (LA) 6	16123 cm <sup>3</sup> 4V	430-546 kW (585-742 PS)	16,5:1	165,00 mm	
<b>TAD1641VE Euro 2</b>	2004 →	D (LA) 6	16123 cm <sup>3</sup> 4V	406-420 kW (552-571 PS)	17,5:1	165,00 mm	
<b>TAD1641VE-B Euro 2</b>		D (LA) 6	16123 cm <sup>3</sup> 4V	450 kW (612 PS)	16,8:1	165,00 mm	
<b>TAD1642GE Euro 2</b>	01.2004 →	D (LA) 6	16123 cm <sup>3</sup> 4V	503-585 kW (684-795 PS)	16,5:1	165,00 mm	
<b>TAD1642VE Euro 2</b>	2004 →	D (LA) 6	16123 cm <sup>3</sup> 4V	480-494 kW (653-672 PS)	17,5:1	165,00 mm	
<b>TAD1642VE-B Euro 2</b>		D (LA) 6	16123 cm <sup>3</sup> 4V	515 kW (700 PS)	16,8:1	165,00 mm	
<b>TAD1643VE Euro 2</b>	2008 →	D (LA) 6	16123 cm <sup>3</sup> 4V	543-565 kW (738-768 PS)	17,5:1	165,00 mm	
<b>TAD1643VE-B Euro 2</b>		D (LA) 6	16123 cm <sup>3</sup> 4V	565 kW (768 PS)	17:1	165,00 mm	
<b>TAD1650GE Euro 3</b>	01.2008 →	D (LA) 6	16123 cm <sup>3</sup> 4V	393-479 kW (534-651 PS)	16,5:1	165,00 mm	
<b>TAD1650VE Euro 3</b>	2008 →	D (LA) 6	16123 cm <sup>3</sup> 4V	397 kW (540 PS)	18:1	165,00 mm	
<b>TAD1651GE Euro 3</b>	01.2008 →	D (LA) 6	16123 cm <sup>3</sup> 4V	430-546 kW (585-742 PS)	16,5:1	165,00 mm	
<b>TAD1660VE Euro 3</b>	01.2010 →	D (LA) 6	16123 cm <sup>3</sup> 4V	405 kW (551 PS)	16,8:1	165,00 mm	
<b>TAD1661VE Euro 3</b>	01.2008 →	D (LA) 6	16123 cm <sup>3</sup> 4V	450 kW (612 PS)	16,8:1	165,00 mm	
<b>TAD1662VE Euro 3</b>	01.2008 →	D (LA) 6	16123 cm <sup>3</sup> 4V	515 kW (700 PS)	16,8:1	165,00 mm	
<b>TWD1643GE Euro 2</b>	2007 →	D (LA) 6	16123 cm <sup>3</sup> 4V	536-644 kW (729-876 PS)	16,5:1	165,00 mm	
<b>TWD1644GE Euro 2</b>		D (LA) 6	16123 cm <sup>3</sup> 4V	554-640 kW (753-870 PS)	16,8:1	165,00 mm	
<b>TWD1645GE Euro 2</b>		D (LA) 6	16123 cm <sup>3</sup> 4V	595-681 kW (809-926 PS)	16,8:1	165,00 mm	
<b>TWD1652GE Euro 3</b>		D (LA) 6	16123 cm <sup>3</sup> 4V	505-557 kW (687-757 PS)	16,5:1	165,00 mm	
<b>TWD1653GE Euro 3</b>		D (LA) 6	16123 cm <sup>3</sup> 4V	547-604 kW (744-821 PS)	16,5:1	165,00 mm	
<b>TWD1663GE Euro 4</b>	01.2008 →	D (LA) 6	16123 cm <sup>3</sup> 4V	593-655 kW (806-891 PS)	16,8:1	165,00 mm	
<b>TWD1672GE Euro 4</b>		D (LA) 6	16123 cm <sup>3</sup> 4V	532-585 kW (723-795 PS)	16,8:1	165,00 mm	
<b>TWD1673GE Euro 4</b>		D (LA) 6	16123 cm <sup>3</sup> 4V	595-655 kW (809-891 PS)	16,8:1	165,00 mm	
<b>TWD1683GE Euro 4</b>		D (LA) 6	16123 cm <sup>3</sup> 4V	570-655 kW (775-891 PS)	16,8:1	165,00 mm	
41 797 6.., 41 798 6..							
	IN [2]	49,0 x 10 x 192,9	I/S - Cr -	- 25° - VS -	15 - III	20739057 20739058 24426433	<b>48319</b>
	EX [2]	46,0 x 10 x 191,4	I/S - Cr -	- 45° - VS -	9 - III	20513284 20513285	<b>48330</b>
	[50]	Ø 10 mm				8170995	<b>RK-10H</b>
Fortsetzung nächste Seite / continued on next page / suite page suivante / continuación página próxima / Продолжение на следующей странице							

					Reference	Item No.	
	IN/EX [6]	16,00 x 10 x 83,4	G2		20562837 20916916 21067953	<b>81-47120</b>	
	IN [1]	52,07 x 41.9 x 7,8	G1 20°		3965955	<b>92-47038</b>	
	IN [1]	52,07 x 42 x 7,6	G1 25°		20709467	<b>92-47036</b>	
	EX [2]	49,07 x 39.5 x 7,8	G2 45°		20564028	<b>92-47037</b>	
	EX [1]	49,07 x 38.5 x 7,8	G2 40°		8131798	<b>92-47039</b>	
<b>179</b>		<b>144</b>	<b>D 16 Euro 2 C-A MG, C-A MH, C-B MH</b>				
2006 → D (LA) 6 16120 cm <sup>3</sup> 4V 368-552 kW (501-751 PS) 17,5:1 165,00 mm							
<b>TAD1650VE-B Euro 3</b>							
D (LA) 6 16123 cm <sup>3</sup> 4V 405 kW (551 PS) 17:1 165,00 mm							
<b>TAD1651VE Euro 3</b>							
D (LA) 6 16123 cm <sup>3</sup> 4V 450 kW (612 PS) 17:1 165,00 mm							
41 798 6..							
	IN [2]	49,0 x 10 x 192,9	I/S - Cr -	- 25° - VS -	15 - III	20739057 20739058 24426433	<b>48319</b>
	EX [2]	46,0 x 10 x 191,4	I/S - Cr -	- 45° - VS -	9 - III	20513284 20513285	<b>48330</b>
	[50]	Ø 10 mm				8170995	<b>RK-10H</b>
	IN/EX [6]	16,00 x 10 x 83,4	G2		20562837 20916916 21067953	<b>81-47120</b>	
	IN [1]	52,07 x 42 x 7,6	G1 25°		20709467	<b>92-47036</b>	
	EX [2]	49,07 x 39.5 x 7,8	G2 45°		20564028	<b>92-47037</b>	
<b>180</b>		<b>144</b>	<b>D 16 Euro 2 C-C MH</b>				
01.2006 → 12.2008 D (LA) 6 16120 cm <sup>3</sup> 4V 368-552 kW (501-751 PS) 17,5:1 165,00 mm							
41 798 6..							
	IN [2]	49,0 x 10 x 192,9	I/S - Cr -	- 25° - VS -	15 - III	20739057 20739058 24426433	<b>48319</b>
	EX [2]	46,0 x 10 x 191,4	I/S - Cr -	- 45° - VS -	9 - III	20513284 20513285	<b>48330</b>
	[50]	Ø 10 mm				8170995	<b>RK-10H</b>
	IN [1]	52,07 x 42 x 7,6	G1 25°		20709467	<b>92-47036</b>	
	EX [2]	49,07 x 39.5 x 7,8	G2 45°		20564028	<b>92-47037</b>	
<b>181</b>		<b>144</b>	<b>D 16 Euro 2 C-D MH</b>				
D (LA) 6 16120 cm <sup>3</sup> 4V 368-552 kW (501-751 PS) 17,5:1 165,00 mm							
41 798 6..							
	IN [1]	52,07 x 42 x 7,6	G1 25°		20709467	<b>92-47036</b>	
	EX [2]	49,07 x 39.5 x 7,8	G2 45°		20564028	<b>92-47037</b>	
<b>182</b>		<b>144</b>	<b>TAD1670VE Euro 4</b>				
D (LA) 6 16123 cm <sup>3</sup> 4V 405 kW (551 PS) 16,8:1 165,00 mm							
<b>TAD1671VE Euro 4</b>							
D (LA) 6 16123 cm <sup>3</sup> 4V 450 kW (612 PS) 16,8:1 165,00 mm							
<b>TAD1672VE Euro 4</b>							
D (LA) 6 16123 cm <sup>3</sup> 4V 515 kW (700 PS) 16,8:1 165,00 mm							
Fortsetzung nächste Seite / continued on next page / suite page suivante / continuación página próxima / Продолжение на следующей странице							

V

					Reference	Item No.
 IN [2]	49,0 x 10 x 192,9	I/S - Cr -	- 25° - VS -	15 - III	20739057 20739058 24426433	<b>48319</b>
EX [2]	46,0 x 10 x 191,4	I/S - Cr -	- 45° - VS -	9 - III	20513284 20513285	<b>48330</b>
 [50]	Ø 10 mm				8170995	<b>RK-10H</b>
 IN/EX [6]	16,00 x 10 x 83,4	G2			20562837 20916916 21067953	<b>81-47120</b>
 IN [1] EX [2]	52,07 x 42 x 7,6 49,07 x 39,5 x 7,8	G1 25° G2 45°			20709467 20564028	<b>92-47036</b> <b>92-47037</b>
					20950804 22431891	<b>20 1004 16003</b>



# KS/TRW/BF NO. - APPLICATION

<b>D</b>	<b>KS/TRW/BF-NR. - ANWENDUNG</b>
<b>E</b>	<b>KS/TRW/BF NO. - APPLICATION</b>
<b>F</b>	<b>N° KS/TRW/BF - APPLICATION</b>
<b>ES</b>	<b>KS/TRW/BF-NO. - APICACIONES</b>
<b>RU</b>	<b>KS/TRW/BF p - ПРИМЕНЕНИЕ</b>

Item No.	Type	Pos ( →  )
105-02076	IN	FIAT 102 (→ 243)
105-02077	EX	FIAT 102 (→ 243)
105-03363	IN	FIAT 103 (→ 243)
105-03364	EX	FIAT 103 (→ 243)
105-03365	IN	FIAT 126 (→ 252), 128 (→ 252), 129 (→ 253)
		RENAULT 112 (→ 1015)
		VOLKSWAGEN 401 (→ 1281)
		VOLVO 67 (→ 1355)
105-03366	EX	FIAT 126 (→ 252), 128 (→ 252), 129 (→ 253)
		RENAULT 112 (→ 1015)
		VOLKSWAGEN 401 (→ 1281)
		VOLVO 67 (→ 1355)
105-34048	IN	FORD 150 (→ 344), 151 (→ 344), 155 (→ 345)
105-34049	EX	FORD 150 (→ 344), 151 (→ 344), 155 (→ 345)
105-34949	IN	VOLVO 121 (→ 1383), 122 (→ 1384), ... , 134 (→ 1390), 135 (→ 1390)
105-35037	IN	VOLVO 103 (→ 1371), 104 (→ 1372), ... , 106 (→ 1373), 108 (→ 1375)
105-35099	IN	VOLVO 71 (→ 1356), 72 (→ 1357)
105-35469	EX	FIAT 102 (→ 243)
105-35470	IN	FIAT 103 (→ 243)
105-35471	EX	FIAT 103 (→ 243)
105-35472	IN	FIAT 126 (→ 252), 128 (→ 252), 129 (→ 253)
		RENAULT 112 (→ 1015)
		VOLKSWAGEN 401 (→ 1281)
		VOLVO 67 (→ 1355)
105-35473	EX	FIAT 126 (→ 252), 128 (→ 252), 129 (→ 253)
		RENAULT 112 (→ 1015)
		VOLKSWAGEN 401 (→ 1281)
		VOLVO 67 (→ 1355)
105-35474	IN	ROVER 5 (→ 1023)
105-35475	EX	ROVER 5 (→ 1023)
105-35501	EX	VOLVO 53 (→ 1350)
105-35514	EX	FORD 27 (→ 301), 28 (→ 301), 54 (→ 309)
105-35529	IN	FORD 69 (→ 312), 71 (→ 313)
105-35541	IN	FORD 31 (→ 302)
105-35551	IN	FORD 57 (→ 310), 82 (→ 316), ... , 84 (→ 317), 85 (→ 317)
105-35552	EX	FORD 57 (→ 310), 84 (→ 317), 85 (→ 317)
105-35615	IN	FORD 147 (→ 344), 148 (→ 344)
		VOLKSWAGEN 402 (→ 1281)
105-35616	EX	FORD 147 (→ 344), 148 (→ 344)
		VOLKSWAGEN 402 (→ 1281)
105-35617	IN	VOLKSWAGEN 405 (→ 1282)
105-35618	EX	VOLKSWAGEN 405 (→ 1282)
105-35632	IN	FIAT 130 (→ 253), 131 (→ 253)
		FORD 152 (→ 345), 153 (→ 345)
		NISSAN 44 (→ 940)
		VOLKSWAGEN 403 (→ 1281)
105-35633	EX	FIAT 130 (→ 253), 131 (→ 253)
		FORD 152 (→ 345), 153 (→ 345)
		NISSAN 44 (→ 940)
		VOLKSWAGEN 403 (→ 1281)
105-35644	IN	FORD 158 (→ 346)
105-35645	EX	FORD 158 (→ 346)
105-35646	IN	FORD 156 (→ 345)
105-35647	EX	FORD 156 (→ 345)
11102	IN	BMW 86 (→ 192)
111031	EX	BMW 79 (→ 191), 87 (→ 192), 90 (→ 193)
11104	IN	BMW 50 (→ 180)
111113	IN/EX	BMW 16 (→ 169), 59 (→ 184), ... , 67 (→ 187), 68 (→ 187)
		ROVER 13 (→ 1024)
111200	EX	BMW 35 (→ 174), 36 (→ 175), 37 (→ 175)
111201	EX	BMW 4 (→ 165), 29 (→ 172)
111202	EX	BMW 95 (→ 194)

Item No.	Type	Pos (→  )
111203	EX	BMW 85 (→ 192), 96 (→ 194)
111208	IN	BMW 43 (→ 178), 44 (→ 178), ... , 88 (→ 193), 91 (→ 193)
111209	EX	BMW 42 (→ 177), 43 (→ 178), ... , 88 (→ 193), 91 (→ 193)
111210	IN	BMW 42 (→ 177), 45 (→ 178)
111211	IN	BMW 23 (→ 171)
111212	EX	BMW 23 (→ 171)
111213	IN	BMW 45 (→ 178), 48 (→ 180)
111214	EX	BMW 45 (→ 178), 47 (→ 179), 48 (→ 180)
111215	EX	BMW 61 (→ 185), 62 (→ 185), 63 (→ 186), 65 (→ 186)
111216	IN	BMW 61 (→ 185), 62 (→ 185), 63 (→ 186), 65 (→ 186)
111217	IN	BMW 22 (→ 171)
111218	EX	BMW 22 (→ 171)
111219	IN	BMW 71 (→ 188)
111220	EX	BMW 71 (→ 188)
111221	IN	BMW 68 (→ 187)
111222	IN	BMW 47 (→ 179)
111223	IN	BMW 46 (→ 179), 49 (→ 180), 57 (→ 183)
111225	EX	BMW 46 (→ 179), 49 (→ 180), 57 (→ 183)
111226	IN	BMW 5 (→ 165)
111227	IN	BMW 6 (→ 165)
111228	EX	BMW 6 (→ 165)
111229	IN	BMW 80 (→ 191), 82 (→ 191)
111230	EX	BMW 80 (→ 191), 82 (→ 191)
111231	IN	BMW 7 (→ 166), 97 (→ 195)
111232	EX	BMW 7 (→ 166), 97 (→ 195)
111233	EX	BMW 25 (→ 172), 26 (→ 172), ... , 30 (→ 173), 31 (→ 173)
111234	IN	BMW 25 (→ 172), 26 (→ 172), ... , 30 (→ 173), 31 (→ 173)
11129	EX	BMW 50 (→ 180)
11131	IN	BMW 35 (→ 174), 36 (→ 175), 37 (→ 175)
111800	IN	BMW 73 (→ 189), 74 (→ 189)
111801	EX	BMW 73 (→ 189), 74 (→ 189)
11211	IN	BMW 93 (→ 194)
1123	EX	BMW 77 (→ 190)
1125	EX	BMW 75 (→ 189), 78 (→ 190), ... , 89 (→ 193), 92 (→ 194)
1132	IN	BMW 77 (→ 190)
1135	IN	BMW 4 (→ 165), 29 (→ 172), 85 (→ 192), 95 (→ 194)
11357	IN	BMW 9 (→ 166), 10 (→ 167), 13 (→ 168)
11358	EX	BMW 9 (→ 166), 10 (→ 167), 13 (→ 168)
11359	IN	BMW 51 (→ 180), 53 (→ 181)
11360	EX	BMW 51 (→ 180), 53 (→ 181)
1142	IN	BMW 75 (→ 189), 78 (→ 190), 89 (→ 193), 92 (→ 194)
11539	IN	BMW 79 (→ 191), 87 (→ 192), 90 (→ 193)
1154	IN	BMW 96 (→ 194)
1155	IN	BMW 8 (→ 166), 12 (→ 167), 34 (→ 174)
1156	EX	BMW 8 (→ 166), 12 (→ 167), 34 (→ 174)
11612	EX	BMW 9 (→ 166), 10 (→ 167), 11 (→ 167), 13 (→ 168)
11613	IN	BMW 9 (→ 166), 10 (→ 167), 11 (→ 167), 13 (→ 168)
11672	EX	BMW 32 (→ 173), 41 (→ 177), ... , 69 (→ 187), 76 (→ 190)
11673	IN	BMW 32 (→ 173), 41 (→ 177), ... , 69 (→ 187), 76 (→ 190)
11732	IN	BMW 15 (→ 168), 18 (→ 169), ... , 20 (→ 170), 21 (→ 170)
1180	IN	BMW 14 (→ 168), 17 (→ 169)
1184	EX	BMW 14 (→ 168), 17 (→ 169)
1195	IN	BMW 33 (→ 174), 84 (→ 192)
11960	IN	BMW 38 (→ 176), 40 (→ 176), ... , 53 (→ 181), 70 (→ 188)
11964	EX	BMW 38 (→ 176), 40 (→ 176), ... , 53 (→ 181), 70 (→ 188)
1198	EX	BMW 33 (→ 174), 84 (→ 192)
160054	IN	MERCEDES-BENZ 437 (→ 788), 440 (→ 791), ... , 550 (→ 910), 553 (→ 912)
160055	EX	MERCEDES-BENZ 437 (→ 788), 440 (→ 791), ... , 550 (→ 910), 553 (→ 912)
160056	IN	MERCEDES-BENZ 238 (→ 615), 239 (→ 616), ... , 312 (→ 662), 313 (→ 662)
160057	EX	MERCEDES-BENZ 238 (→ 615), 239 (→ 616), ... , 308 (→ 660), 310 (→ 661)
1604	EX	FORD 145 (→ 343)
		MERCEDES-BENZ 128 (→ 545), 129 (→ 546), ... , 234 (→ 613), 235 (→ 614)

KS/TRW/BF No. → Application

Item No.	Type	Pos ( →  )
1606	IN	MERCEDES-BENZ 315 (→ 663), 322 (→ 666), ... , 475 (→ 824), 476 (→ 826)
1608	EX	MERCEDES-BENZ 315 (→ 663), 322 (→ 666), ... , 475 (→ 824), 476 (→ 826)
1610	EX	MERCEDES-BENZ 321 (→ 665)
16106	EX	FORD 145 (→ 343)
		MERCEDES-BENZ 128 (→ 545), 129 (→ 546), ... , 235 (→ 614), 236 (→ 615)
16109	IN	MERCEDES-BENZ 128 (→ 545), 131 (→ 548), ... , 235 (→ 614), 236 (→ 615)
16116	EX	MERCEDES-BENZ 315 (→ 663), 322 (→ 666), ... , 509 (→ 859), 541 (→ 902)
16117	IN	MERCEDES-BENZ 315 (→ 663), 322 (→ 666), ... , 509 (→ 859), 541 (→ 902)
16122	EX	FORD 145 (→ 343)
		MERCEDES-BENZ 128 (→ 545), 129 (→ 546), ... , 235 (→ 614), 236 (→ 615)
16130	IN	MERCEDES-BENZ 140 (→ 554), 144 (→ 557), ... , 235 (→ 614), 236 (→ 615)
16136	IN	FORD 145 (→ 343)
		MERCEDES-BENZ 128 (→ 545), 129 (→ 546), ... , 235 (→ 614), 236 (→ 615)
16146	IN	MERCEDES-BENZ 315 (→ 663), 322 (→ 666), ... , 509 (→ 859), 541 (→ 902)
16150	EX	MERCEDES-BENZ 315 (→ 663), 322 (→ 666), ... , 509 (→ 859), 541 (→ 902)
16200	IN	MERCEDES-BENZ 238 (→ 615), 239 (→ 616), ... , 307 (→ 659), 308 (→ 660)
16202	IN	MERCEDES-BENZ 354 (→ 702), 355 (→ 703), 356 (→ 703)
162031	EX	MERCEDES-BENZ 354 (→ 702), 355 (→ 703), 356 (→ 703)
16204	IN	MERCEDES-BENZ 437 (→ 788), 440 (→ 791), ... , 554 (→ 913), 555 (→ 914)
16205	EX	MERCEDES-BENZ 437 (→ 788), 440 (→ 791), ... , 554 (→ 913), 555 (→ 914)
16210	EX	MERCEDES-BENZ 238 (→ 615), 239 (→ 616), ... , 312 (→ 662), 313 (→ 662)
16211	IN	MERCEDES-BENZ 556 (→ 915), 560 (→ 916), 561 (→ 917)
16212	EX	MERCEDES-BENZ 556 (→ 915), 560 (→ 916), 561 (→ 917)
16213	IN	MERCEDES-BENZ 316 (→ 664), 317 (→ 665), 318 (→ 665)
16215	EX	MERCEDES-BENZ 316 (→ 664), 317 (→ 665), 318 (→ 665)
162160	IN	MERCEDES-BENZ 341 (→ 691), 351 (→ 701), 352 (→ 701)
162170	EX	MERCEDES-BENZ 341 (→ 691), 351 (→ 701), 352 (→ 701)
162180	IN	MERCEDES-BENZ 567 (→ 918), 570 (→ 919)
162190	EX	MERCEDES-BENZ 567 (→ 918), 570 (→ 919)
1657	IN	MERCEDES-BENZ 359 (→ 704), 360 (→ 704), ... , 473 (→ 823), 474 (→ 824)
1658	EX	MERCEDES-BENZ 359 (→ 704), 360 (→ 704), ... , 473 (→ 823), 474 (→ 824)
1659	IN	MERCEDES-BENZ 321 (→ 665)
17032	EX	FIAT 101 (→ 243), 105 (→ 244), 107 (→ 244)
17043	EX	FIAT 119 (→ 250), 127 (→ 252), 133 (→ 254), 134 (→ 254)
17055	EX	FIAT 14 (→ 221), 16 (→ 221)
		LANCIA 6 (→ 353)
17061	EX	FIAT 62 (→ 232)
		LANCIA 28 (→ 358)
17063	EX	FIAT 104 (→ 244), 109 (→ 246), ... , 112 (→ 247), 113 (→ 247)
		LANCIA 53 (→ 364)
		RENAULT 98 (→ 1010), 100 (→ 1011), 101 (→ 1011), 103 (→ 1012)
17072	EX	FIAT 139 (→ 257)
17075	IN	FIAT 135 (→ 255), 136 (→ 256)
17076	EX	FIAT 135 (→ 255), 136 (→ 256)
17080	IN	FIAT 118 (→ 249)
		RENAULT 106 (→ 1013)
17089	IN	FIAT 92 (→ 240)
		LANCIA 45 (→ 362)
171003	EX	FIAT 46 (→ 227), 49 (→ 228)
		LANCIA 17 (→ 355), 20 (→ 356), 21 (→ 356)
171004	EX	FIAT 45 (→ 227), 49 (→ 228)
		LANCIA 17 (→ 355), 19 (→ 356), 21 (→ 356), 29 (→ 358)
171005	IN	FIAT 46 (→ 227), 49 (→ 228)
		LANCIA 17 (→ 355), 20 (→ 356), 21 (→ 356)
171014	EX	FIAT 50 (→ 228)
		LANCIA 22 (→ 357)
171018	EX	FIAT 138 (→ 256)
171019	IN	FIAT 137 (→ 256)
		MERCEDES-BENZ 230 (→ 611)
171036	IN	FIAT 42 (→ 226), 89 (→ 239), ... , 93 (→ 241), 94 (→ 241)
		LANCIA 16 (→ 355), 46 (→ 363), 47 (→ 363)
171037	EX	FIAT 42 (→ 226), 89 (→ 239), 93 (→ 241), 94 (→ 241)

Item No.	Type	Pos (→  )
		LANCIA 16 (→ 355), 46 (→ 363), 47 (→ 363)
171043	EX	FIAT 89 (→ 239), 93 (→ 241), 94 (→ 241)
		LANCIA 46 (→ 363), 47 (→ 363)
171046	IN	FIAT 51 (→ 228), 52 (→ 229)
		LANCIA 23 (→ 357), 25 (→ 358)
171052	IN	FIAT 18 (→ 222)
		LANCIA 9 (→ 353)
171053	EX	FIAT 18 (→ 222)
		LANCIA 9 (→ 353)
171055	EX	FIAT 98 (→ 242), 101 (→ 243), ... , 117 (→ 249), 118 (→ 249)
		LANCIA 52 (→ 364), 53 (→ 364)
		RENAULT 100 (→ 1011), 103 (→ 1012), 105 (→ 1013), 106 (→ 1013)
171062	EX	FIAT 51 (→ 228), 52 (→ 229)
		LANCIA 23 (→ 357), 25 (→ 358)
171070	IN	FIAT 140 (→ 257), 141 (→ 257)
171072	IN	FIAT 143 (→ 258)
		FORD 161 (→ 346)
171108	EX	FIAT 140 (→ 257), 141 (→ 257)
171109	EX	FIAT 143 (→ 258)
		FORD 161 (→ 346)
171110	EX	FIAT 145 (→ 259)
171111	IN	FIAT 144 (→ 258)
171112	EX	FIAT 144 (→ 258)
171113	IN	FIAT 99 (→ 242), 100 (→ 242)
171114	EX	FIAT 99 (→ 242), 100 (→ 242)
171115	IN	FIAT 120 (→ 250), 121 (→ 250), 124 (→ 251), 125 (→ 251)
171116	EX	FIAT 120 (→ 250), 121 (→ 250), 124 (→ 251), 125 (→ 251)
171117	IN	FIAT 19 (→ 222), 20 (→ 222), 22 (→ 222)
		FORD 4 (→ 292)
		LANCIA 10 (→ 354)
171118	EX	FIAT 19 (→ 222), 20 (→ 222), 22 (→ 222)
		FORD 4 (→ 292)
		LANCIA 10 (→ 354)
171120	IN	FIAT 98 (→ 242), 101 (→ 243), ... , 117 (→ 249), 118 (→ 249)
		LANCIA 52 (→ 364), 53 (→ 364)
		RENAULT 98 (→ 1010), 99 (→ 1011), ... , 106 (→ 1013), 107 (→ 1013)
171121	EX	FIAT 142 (→ 258)
171124	IN	FIAT 33 (→ 224), 34 (→ 224)
		LANCIA 15 (→ 355)
171125	IN	FIAT 23 (→ 223)
		LANCIA 12 (→ 354)
171126	EX	FIAT 23 (→ 223)
		LANCIA 12 (→ 354)
17165	IN	FIAT 142 (→ 258)
181008	EX	FORD 40 (→ 304)
181009	IN	FORD 40 (→ 304)
181012	IN	FORD 59 (→ 310), 82 (→ 316)
181014	IN	FORD 70 (→ 313), 73 (→ 314), 74 (→ 315)
181015	EX	FORD 70 (→ 313), 73 (→ 314), 74 (→ 315)
181016	IN	FORD 121 (→ 334), 122 (→ 334), ... , 126 (→ 337), 127 (→ 338)
181018	IN	FORD 90 (→ 319), 91 (→ 320), ... , 126 (→ 337), 128 (→ 339)
181019	EX	FORD 90 (→ 319), 91 (→ 320), ... , 126 (→ 337), 128 (→ 339)
181021	EX	FORD 59 (→ 310), 83 (→ 316)
181101	EX	FORD 155 (→ 345)
181102	IN	FORD 13 (→ 296), 14 (→ 297), 15 (→ 297)
181103	EX	FORD 13 (→ 296), 14 (→ 297), 15 (→ 297)
181104	IN	FIAT 75 (→ 235), 76 (→ 236), ... , 80 (→ 237), 81 (→ 237)
		FORD 87 (→ 318), 88 (→ 318)
		LANCIA 38 (→ 360), 39 (→ 361), 42 (→ 362)
		VOLVO 45 (→ 1348)
181105	EX	FIAT 75 (→ 235), 76 (→ 236), ... , 81 (→ 237), 84 (→ 238)
		FORD 87 (→ 318), 88 (→ 318), ... , 93 (→ 321), 94 (→ 321)

KS/TRW/BF No. → Application

Item No.	Type	Pos ( →  )
		LANCIA 38 (→ 360), 39 (→ 361), 42 (→ 362)
		VOLVO 45 (→ 1348)
181106	IN	FORD 40 (→ 304), 42 (→ 305)
		VOLVO 9 (→ 1339)
181107	EX	FORD 32 (→ 302), 40 (→ 304), 42 (→ 305)
		VOLVO 9 (→ 1339)
181108	IN	FORD 115 (→ 333)
		VOLVO 46 (→ 1349)
181109	EX	FORD 115 (→ 333)
		VOLVO 46 (→ 1349)
181110	IN	FORD 75 (→ 315)
		VOLVO 42 (→ 1348)
181111	EX	FORD 75 (→ 315)
		VOLVO 42 (→ 1348)
181112	IN	FORD 6 (→ 292), 7 (→ 293)
181113	EX	FORD 6 (→ 292), 7 (→ 293)
181115	IN	FORD 32 (→ 302)
181117	IN	FIAT 84 (→ 238)
		FORD 92 (→ 320), 93 (→ 321), 94 (→ 321)
181118	EX	FORD 8 (→ 294), 9 (→ 294)
181120	IN	FORD 8 (→ 294), 9 (→ 294)
18345	EX	FORD 69 (→ 312), 70 (→ 313), 71 (→ 313), 72 (→ 314)
18374	IN	FORD 70 (→ 313), 72 (→ 314)
18375	EX	FORD 69 (→ 312), 70 (→ 313), 71 (→ 313), 72 (→ 314)
18391	EX	FORD 58 (→ 310), 84 (→ 317), 102 (→ 324)
22155	EX	FORD 159 (→ 346), 160 (→ 346)
22202	IN	FORD 159 (→ 346), 160 (→ 346)
22220	EX	VOLVO 84 (→ 1361), 85 (→ 1362), 90 (→ 1364)
22221	IN	VOLVO 84 (→ 1361), 85 (→ 1362), 90 (→ 1364)
22307	IN	VOLVO 65 (→ 1354), 70 (→ 1356)
22308	EX	VOLVO 65 (→ 1354), 70 (→ 1356)
22314	IN	VOLVO 85 (→ 1362), 87 (→ 1362)
22315	EX	VOLVO 85 (→ 1362), 87 (→ 1362)
22316	IN	VOLVO 83 (→ 1360), 88 (→ 1363), 89 (→ 1363)
22317	EX	VOLVO 83 (→ 1360), 88 (→ 1363), 89 (→ 1363)
2254	IN	FORD 159 (→ 346), 160 (→ 346)
2294	EX	FORD 159 (→ 346), 160 (→ 346)
25304	IN	VOLKSWAGEN 404 (→ 1281)
25305	EX	VOLKSWAGEN 404 (→ 1281)
26017	IN	MERCEDES-BENZ 117 (→ 541)
26024	IN	MERCEDES-BENZ 60 (→ 516), 61 (→ 517), ... , 87 (→ 531), 88 (→ 531)
26032	EX	MERCEDES-BENZ 60 (→ 516), 61 (→ 517), ... , 87 (→ 531), 88 (→ 531)
26045	IN	MERCEDES-BENZ 65 (→ 520), 86 (→ 530)
26046	EX	MERCEDES-BENZ 65 (→ 520), 86 (→ 530)
26047	EX	MERCEDES-BENZ 65 (→ 520), 86 (→ 530)
26048	IN	MERCEDES-BENZ 77 (→ 525), 81 (→ 527), ... , 105 (→ 538), 250 (→ 624)
		VOLKSWAGEN 390 (→ 1278)
260490	EX	MERCEDES-BENZ 81 (→ 527), 89 (→ 532), ... , 105 (→ 538), 250 (→ 624)
		VOLKSWAGEN 390 (→ 1278)
2605	IN	MERCEDES-BENZ 102 (→ 537), 106 (→ 539)
26052	IN	MERCEDES-BENZ 66 (→ 520), 108 (→ 539)
261030	IN	MERCEDES-BENZ 47 (→ 512)
261031	EX	MERCEDES-BENZ 47 (→ 512)
261032	IN	MERCEDES-BENZ 95 (→ 535)
261033	EX	MERCEDES-BENZ 95 (→ 535)
261034	IN	MERCEDES-BENZ 127 (→ 544)
261035	EX	MERCEDES-BENZ 127 (→ 544)
261036	IN	MERCEDES-BENZ 10 (→ 499), 11 (→ 499)
261037	EX	MERCEDES-BENZ 10 (→ 499), 11 (→ 499)
261038	IN	MERCEDES-BENZ 30 (→ 505), 48 (→ 513)
261039	EX	MERCEDES-BENZ 48 (→ 513)
26107	IN	MERCEDES-BENZ 28 (→ 504)



Item No.	Type	Pos (→  )
26109	IN	MERCEDES-BENZ 76 (→ 525)
261100	IN	MERCEDES-BENZ 170 (→ 575), 185 (→ 583), ... , 235 (→ 614), 236 (→ 615)
261101	EX	MERCEDES-BENZ 437 (→ 788), 440 (→ 791), ... , 550 (→ 910), 553 (→ 912)
261102	IN	MERCEDES-BENZ 68 (→ 520), 69 (→ 521), 70 (→ 522), 71 (→ 522)
261103	EX	MERCEDES-BENZ 68 (→ 520), 69 (→ 521), 70 (→ 522), 71 (→ 522)
261106	EX	MERCEDES-BENZ 16 (→ 500), 20 (→ 502), ... , 58 (→ 515), 117 (→ 541)
261107	EX	MERCEDES-BENZ 78 (→ 526), 79 (→ 526), ... , 118 (→ 542), 119 (→ 542)
261108	EX	MERCEDES-BENZ 53 (→ 514), 107 (→ 539)
261109	EX	MERCEDES-BENZ 66 (→ 520), 108 (→ 539)
261110	IN	MERCEDES-BENZ 53 (→ 514), 54 (→ 514)
261111	EX	MERCEDES-BENZ 53 (→ 514), 54 (→ 514), ... , 123 (→ 543), 124 (→ 544)
261112	EX	MERCEDES-BENZ 28 (→ 504)
261113	EX	MERCEDES-BENZ 76 (→ 525)
261114	EX	MERCEDES-BENZ 77 (→ 525), 81 (→ 527), ... , 104 (→ 538), 105 (→ 538)
261117	EX	MERCEDES-BENZ 102 (→ 537), 106 (→ 539)
261118	EX	MERCEDES-BENZ 59 (→ 516), 103 (→ 538)
261119	EX	MERCEDES-BENZ 9 (→ 499), 19 (→ 501)
26112	IN	MERCEDES-BENZ 122 (→ 543), 123 (→ 543), 124 (→ 544)
261121	EX	MERCEDES-BENZ 50 (→ 513), 51 (→ 513)
261122	IN	MERCEDES-BENZ 21 (→ 502), 22 (→ 503)
261123	EX	MERCEDES-BENZ 21 (→ 502), 22 (→ 503)
261124	IN	MERCEDES-BENZ 56 (→ 515), 72 (→ 523), ... , 74 (→ 524), 75 (→ 524)
261125	EX	MERCEDES-BENZ 56 (→ 515), 72 (→ 523), ... , 74 (→ 524), 75 (→ 524)
261126	IN	MERCEDES-BENZ 33 (→ 506), 34 (→ 506), ... , 40 (→ 509), 43 (→ 511)
261127	EX	MERCEDES-BENZ 33 (→ 506), 34 (→ 506), ... , 40 (→ 509), 43 (→ 511)
261128	IN	MERCEDES-BENZ 17 (→ 501), 18 (→ 501), ... , 23 (→ 503), 25 (→ 504)
261129	EX	MERCEDES-BENZ 17 (→ 501), 18 (→ 501), ... , 23 (→ 503), 25 (→ 504)
261130	IN	MERCEDES-BENZ 26 (→ 504), 67 (→ 520)
261131	EX	MERCEDES-BENZ 26 (→ 504), 67 (→ 520)
261132	IN	MERCEDES-BENZ 111 (→ 540), 114 (→ 541)
261133	EX	MERCEDES-BENZ 111 (→ 540), 114 (→ 541)
261135	EX	MERCEDES-BENZ 30 (→ 505)
261140	IN	MERCEDES-BENZ 36 (→ 507), 38 (→ 508), 39 (→ 509), 45 (→ 511)
261141	EX	MERCEDES-BENZ 36 (→ 507), 38 (→ 508), 39 (→ 509), 45 (→ 511)
261142	IN	MERCEDES-BENZ 24 (→ 503)
261143	EX	MERCEDES-BENZ 24 (→ 503)
261148	IN	MERCEDES-BENZ 14 (→ 500), 29 (→ 505), 31 (→ 505), 32 (→ 506)
261149	EX	MERCEDES-BENZ 29 (→ 505), 31 (→ 505)
261150	IN	MERCEDES-BENZ 113 (→ 540), 115 (→ 541), 116 (→ 541)
261151	EX	MERCEDES-BENZ 113 (→ 540)
261152	IN	MERCEDES-BENZ 27 (→ 504)
261153	EX	MERCEDES-BENZ 27 (→ 504)
261154	EX	MERCEDES-BENZ 14 (→ 500), 32 (→ 506)
261155	EX	MERCEDES-BENZ 24 (→ 503)
26135	IN	MERCEDES-BENZ 78 (→ 526), 118 (→ 542), 119 (→ 542)
26139	IN	MERCEDES-BENZ 77 (→ 525)
26160	IN	MERCEDES-BENZ 78 (→ 526), 79 (→ 526), 80 (→ 527), 118 (→ 542)
2619	IN	MERCEDES-BENZ 16 (→ 500), 20 (→ 502), 55 (→ 514), 57 (→ 515)
2620	IN	MERCEDES-BENZ 58 (→ 515)
26208	IN	MERCEDES-BENZ 77 (→ 525), 81 (→ 527), ... , 104 (→ 538), 105 (→ 538)
26264	IN	MERCEDES-BENZ 65 (→ 520), 86 (→ 530)
2635	IN	MERCEDES-BENZ 53 (→ 514), 54 (→ 514)
2639	IN	MERCEDES-BENZ 107 (→ 539), 108 (→ 539), ... , 123 (→ 543), 124 (→ 544)
2641	IN	MERCEDES-BENZ 59 (→ 516), 103 (→ 538)
2656	EX	MERCEDES-BENZ 3 (→ 497), 5 (→ 498)
2660	IN	MERCEDES-BENZ 2 (→ 497), 4 (→ 498), 49 (→ 513)
2664	IN	MERCEDES-BENZ 3 (→ 497), 5 (→ 498)
2666	IN	MERCEDES-BENZ 9 (→ 499), 19 (→ 501)
2675	IN	MERCEDES-BENZ 50 (→ 513), 51 (→ 513)
269000	IN	MERCEDES-BENZ 8 (→ 498)
269001	EX	MERCEDES-BENZ 8 (→ 498)
2691	IN	MERCEDES-BENZ 3 (→ 497), 5 (→ 498)

KS/TRW/BF No. → Application

Item No.	Type		Pos ( →  )
27104	EX	RENAULT	118 (→ 1016)
27119	IN	RENAULT	118 (→ 1016)
2721	EX	RENAULT	108 (→ 1014), 109 (→ 1014)
2723	IN	RENAULT	108 (→ 1014), 109 (→ 1014)
2726	IN	RENAULT	113 (→ 1015), 117 (→ 1016)
2734	IN	RENAULT	119 (→ 1016), 120 (→ 1017)
2757	EX	RENAULT	113 (→ 1015), 117 (→ 1016), 119 (→ 1016), 120 (→ 1017)
2786	IN	RENAULT	110 (→ 1014)
2787	EX	RENAULT	110 (→ 1014)
291109	IN	FIAT	88 (→ 239)
291110	EX	FIAT	88 (→ 239)
291111	IN	FIAT	7 (→ 219), 8 (→ 219), 10 (→ 220)
		FORD	2 (→ 292)
		LANCIA	3 (→ 352)
291112	EX	FIAT	7 (→ 219), 8 (→ 219), 10 (→ 220)
		FORD	2 (→ 292)
		LANCIA	3 (→ 352)
291113	IN	FIAT	34 (→ 224), 35 (→ 225), ... , 57 (→ 231), 69 (→ 234)
		LANCIA	14 (→ 354), 24 (→ 357), 30 (→ 359)
291114	IN	FIAT	34 (→ 224), 35 (→ 225), ... , 57 (→ 231), 69 (→ 234)
		LANCIA	14 (→ 354), 24 (→ 357), 30 (→ 359)
291115	EX	FIAT	34 (→ 224), 35 (→ 225), ... , 57 (→ 231), 69 (→ 234)
		LANCIA	14 (→ 354), 24 (→ 357), 30 (→ 359)
291116	EX	FIAT	33 (→ 224), 34 (→ 224), ... , 57 (→ 231), 69 (→ 234)
		LANCIA	14 (→ 354), 15 (→ 355), 24 (→ 357), 30 (→ 359)
291117	IN	FIAT	43 (→ 226)
291118	EX	FIAT	43 (→ 226)
291129	IN	FIAT	9 (→ 219), 12 (→ 220)
		LANCIA	4 (→ 352)
291130	EX	FIAT	9 (→ 219), 12 (→ 220)
		LANCIA	4 (→ 352)
33008	EX	VOLKSWAGEN	119 (→ 1167), 120 (→ 1167), ... , 377 (→ 1274), 378 (→ 1274)
33009	IN	VOLKSWAGEN	118 (→ 1166), 119 (→ 1167), ... , 379 (→ 1275), 380 (→ 1275)
33012	EX	VOLKSWAGEN	389 (→ 1277), 392 (→ 1278), 394 (→ 1278), 395 (→ 1279)
33014	IN	VOLKSWAGEN	389 (→ 1277), 392 (→ 1278), 394 (→ 1278), 395 (→ 1279)
33016	EX	VOLKSWAGEN	118 (→ 1166), 119 (→ 1167), ... , 377 (→ 1274), 380 (→ 1275)
33022	IN	VOLKSWAGEN	130 (→ 1170), 191 (→ 1198), ... , 214 (→ 1207), 258 (→ 1225)
33023	EX	VOLKSWAGEN	130 (→ 1170), 191 (→ 1198), ... , 214 (→ 1207), 258 (→ 1225)
33025	EX	VOLKSWAGEN	30 (→ 1132), 33 (→ 1133), ... , 127 (→ 1170), 131 (→ 1171)
33044	IN	VOLKSWAGEN	100 (→ 1159), 133 (→ 1171)
		VOLVO	6 (→ 1338), 7 (→ 1338)
33046	IN	VOLKSWAGEN	29 (→ 1132), 37 (→ 1134), ... , 47 (→ 1137), 94 (→ 1158)
33048	EX	VOLKSWAGEN	190 (→ 1197), 191 (→ 1198), ... , 297 (→ 1243), 299 (→ 1244)
33049	EX	SKODA	40 (→ 1051), 43 (→ 1052)
		VOLKSWAGEN	48 (→ 1137), 134 (→ 1171), ... , 154 (→ 1181), 155 (→ 1181)
33050	EX	VOLKSWAGEN	211 (→ 1206), 296 (→ 1242)
331033	IN	FORD	46 (→ 306), 47 (→ 307)
		SKODA	45 (→ 1053), 47 (→ 1054), ... , 49 (→ 1055), 56 (→ 1059)
		VOLKSWAGEN	156 (→ 1182), 157 (→ 1182), ... , 265 (→ 1228), 268 (→ 1229)
331034	EX	FORD	46 (→ 306), 47 (→ 307)
		SKODA	45 (→ 1053), 47 (→ 1054), 48 (→ 1055), 49 (→ 1055)
		VOLKSWAGEN	156 (→ 1182), 157 (→ 1182), ... , 265 (→ 1228), 268 (→ 1229)
331040	IN	FORD	63 (→ 311), 64 (→ 311)
		VOLKSWAGEN	225 (→ 1211), 233 (→ 1214), 238 (→ 1216)
331041	IN	FORD	65 (→ 311)
		VOLKSWAGEN	245 (→ 1219), 246 (→ 1220), ... , 362 (→ 1269), 368 (→ 1271)
331042	EX	FORD	65 (→ 311)
		VOLKSWAGEN	245 (→ 1219), 246 (→ 1220), ... , 362 (→ 1269), 368 (→ 1271)
331046	IN	VOLKSWAGEN	54 (→ 1139), 59 (→ 1142)
331047	EX	SKODA	23 (→ 1042), 24 (→ 1042)
		VOLKSWAGEN	54 (→ 1139), 59 (→ 1142), ... , 67 (→ 1146), 95 (→ 1158)
331049	IN	VOLKSWAGEN	116 (→ 1166)

Item No.	Type	Pos (→  )
331050	EX	VOLKSWAGEN 116 (→ 1166)
331055	IN	SKODA 38 (→ 1049)
		VOLKSWAGEN 122 (→ 1167), 123 (→ 1168)
331056	EX	SKODA 38 (→ 1049)
		VOLKSWAGEN 122 (→ 1167), 123 (→ 1168)
331057	IN	SKODA 69 (→ 1064), 70 (→ 1065), 72 (→ 1066), 73 (→ 1066)
		VOLKSWAGEN 189 (→ 1197), 252 (→ 1222), ... , 256 (→ 1224), 257 (→ 1224)
331058	EX	SKODA 69 (→ 1064), 70 (→ 1065), 72 (→ 1066), 73 (→ 1066)
		VOLKSWAGEN 189 (→ 1197), 252 (→ 1222), ... , 256 (→ 1224), 257 (→ 1224)
331101	EX	VOLKSWAGEN 98 (→ 1159), 99 (→ 1159), ... , 113 (→ 1165), 133 (→ 1171)
		VOLVO 6 (→ 1338), 7 (→ 1338)
331102	EX	VOLKSWAGEN 99 (→ 1159), 100 (→ 1159), ... , 114 (→ 1165), 115 (→ 1166)
331103	IN	VOLKSWAGEN 99 (→ 1159), 104 (→ 1161), ... , 113 (→ 1165), 114 (→ 1165)
331104	EX	VOLKSWAGEN 32 (→ 1133), 34 (→ 1133), 35 (→ 1133)
331107	EX	SKODA 64 (→ 1062), 87 (→ 1072)
		VOLKSWAGEN 237 (→ 1216), 240 (→ 1217), 242 (→ 1218), 302 (→ 1245)
331108	EX	SKODA 66 (→ 1063), 67 (→ 1063), 68 (→ 1064), 71 (→ 1065)
		VOLKSWAGEN 239 (→ 1217), 243 (→ 1219), ... , 250 (→ 1221), 251 (→ 1221)
331109	EX	FORD 63 (→ 311), 64 (→ 311)
		VOLKSWAGEN 225 (→ 1211), 233 (→ 1214)
331110	IN	SKODA 39 (→ 1050)
		VOLKSWAGEN 124 (→ 1169)
331111	EX	SKODA 39 (→ 1050)
		VOLKSWAGEN 124 (→ 1169)
331112	EX	VOLKSWAGEN 393 (→ 1278)
331113	IN	VOLKSWAGEN 393 (→ 1278)
331116	IN	SKODA 88 (→ 1073)
		VOLKSWAGEN 307 (→ 1248), 308 (→ 1248), ... , 374 (→ 1274), 375 (→ 1274)
331117	EX	SKODA 88 (→ 1073), 92 (→ 1075), ... , 95 (→ 1077), 96 (→ 1077)
		VOLKSWAGEN 307 (→ 1248), 308 (→ 1248), ... , 340 (→ 1261), 341 (→ 1262)
331119	IN	SKODA 74 (→ 1066), 79 (→ 1069)
		VOLKSWAGEN 267 (→ 1229), 275 (→ 1234), ... , 277 (→ 1235), 279 (→ 1236)
331120	EX	SKODA 74 (→ 1066), 79 (→ 1069)
		VOLKSWAGEN 267 (→ 1229), 275 (→ 1234), ... , 277 (→ 1235), 279 (→ 1236)
331121	IN	SKODA 74 (→ 1066), 79 (→ 1069)
		VOLKSWAGEN 267 (→ 1229), 275 (→ 1234), ... , 277 (→ 1235), 279 (→ 1236)
331122	EX	SKODA 74 (→ 1066), 79 (→ 1069)
		VOLKSWAGEN 267 (→ 1229), 275 (→ 1234), ... , 277 (→ 1235), 279 (→ 1236)
331123	IN	SKODA 46 (→ 1053), 48 (→ 1055), ... , 78 (→ 1069), 80 (→ 1069)
		VOLKSWAGEN 158 (→ 1183), 159 (→ 1183), ... , 284 (→ 1238), 285 (→ 1238)
331124	EX	SKODA 46 (→ 1053), 48 (→ 1055), ... , 78 (→ 1069), 80 (→ 1069)
		VOLKSWAGEN 158 (→ 1183), 159 (→ 1183), ... , 284 (→ 1238), 285 (→ 1238)
331125	IN	SKODA 89 (→ 1073), 90 (→ 1074), ... , 93 (→ 1076), 101 (→ 1079)
		VOLKSWAGEN 309 (→ 1249), 310 (→ 1249), ... , 322 (→ 1254), 343 (→ 1262)
331126	EX	SKODA 89 (→ 1073), 90 (→ 1074), 91 (→ 1074), 101 (→ 1079)
		VOLKSWAGEN 309 (→ 1249), 310 (→ 1249), ... , 370 (→ 1272), 374 (→ 1274)
331127	IN	SKODA 102 (→ 1079)
		VOLKSWAGEN 364 (→ 1270), 365 (→ 1270), ... , 387 (→ 1277), 388 (→ 1277)
331128	IN	SKODA 102 (→ 1079)
		VOLKSWAGEN 364 (→ 1270), 365 (→ 1270), ... , 387 (→ 1277), 388 (→ 1277)
331129	EX	SKODA 102 (→ 1079)
		VOLKSWAGEN 364 (→ 1270), 365 (→ 1270), ... , 387 (→ 1277), 388 (→ 1277)
331130	EX	SKODA 102 (→ 1079)
		VOLKSWAGEN 364 (→ 1270), 365 (→ 1270), ... , 387 (→ 1277), 388 (→ 1277)
331131	IN	SKODA 62 (→ 1061), 75 (→ 1067), ... , 82 (→ 1071), 83 (→ 1071)
		VOLKSWAGEN 185 (→ 1196), 272 (→ 1232), ... , 357 (→ 1268), 360 (→ 1269)
331132	EX	SKODA 62 (→ 1061), 75 (→ 1067), ... , 82 (→ 1071), 83 (→ 1071)
		VOLKSWAGEN 185 (→ 1196), 272 (→ 1232), ... , 357 (→ 1268), 360 (→ 1269)
331133	IN	VOLKSWAGEN 348 (→ 1263), 349 (→ 1264), ... , 360 (→ 1269), 361 (→ 1269)
331134	EX	VOLKSWAGEN 348 (→ 1263), 349 (→ 1264), ... , 358 (→ 1268), 361 (→ 1269)
331135	IN	FORD 65 (→ 311)
		VOLKSWAGEN 245 (→ 1219), 246 (→ 1220), ... , 362 (→ 1269), 368 (→ 1271)

Item No.	Type	Pos (→  )
331136	EX	FORD 65 (→ 311) VOLKSWAGEN 245 (→ 1219), 246 (→ 1220), ... , 362 (→ 1269), 368 (→ 1271)
331137	IN	SKODA 23 (→ 1042), 24 (→ 1042) VOLKSWAGEN 63 (→ 1144), 65 (→ 1145), ... , 67 (→ 1146), 95 (→ 1158)
331138	IN	VOLKSWAGEN 311 (→ 1250), 312 (→ 1250)
331139	IN	VOLKSWAGEN 2 (→ 1125), 3 (→ 1125)
331140	EX	VOLKSWAGEN 2 (→ 1125), 3 (→ 1125)
331141	IN	FORD 44 (→ 306) VOLKSWAGEN 138 (→ 1174), 140 (→ 1175), 259 (→ 1225), 260 (→ 1226) VOLVO 23 (→ 1342)
331142	EX	FORD 44 (→ 306) VOLKSWAGEN 138 (→ 1174), 140 (→ 1175), ... , 282 (→ 1237), 283 (→ 1238) VOLVO 23 (→ 1342)
331143	EX	FORD 44 (→ 306), 45 (→ 306) SKODA 41 (→ 1051), 42 (→ 1051) VOLKSWAGEN 138 (→ 1174), 140 (→ 1175), ... , 164 (→ 1186), 187 (→ 1196)
331144	EX	SKODA 88 (→ 1073), 92 (→ 1075), ... , 95 (→ 1077), 96 (→ 1077) VOLKSWAGEN 307 (→ 1248), 308 (→ 1248), ... , 339 (→ 1261), 340 (→ 1261)
331147	IN	VOLKSWAGEN 163 (→ 1186)
331151	IN	SKODA 57 (→ 1059), 58 (→ 1060), ... , 61 (→ 1061), 62 (→ 1061) VOLKSWAGEN 181 (→ 1194), 182 (→ 1195), ... , 185 (→ 1196), 186 (→ 1196)
331153	IN	SKODA 1 (→ 1035) VOLKSWAGEN 8 (→ 1126), 9 (→ 1127), 10 (→ 1127)
331154	EX	SKODA 57 (→ 1059), 58 (→ 1060), ... , 61 (→ 1061), 62 (→ 1061) VOLKSWAGEN 181 (→ 1194), 182 (→ 1195), ... , 357 (→ 1268), 359 (→ 1268)
331155	EX	SKODA 1 (→ 1035) VOLKSWAGEN 8 (→ 1126), 9 (→ 1127), 10 (→ 1127)
331156	IN	SKODA 2 (→ 1035), 3 (→ 1035), ... , 6 (→ 1036), 7 (→ 1036) VOLKSWAGEN 11 (→ 1127), 12 (→ 1128), ... , 15 (→ 1128), 16 (→ 1129)
331157	EX	SKODA 2 (→ 1035), 3 (→ 1035), ... , 6 (→ 1036), 7 (→ 1036) VOLKSWAGEN 11 (→ 1127), 12 (→ 1128), ... , 15 (→ 1128), 16 (→ 1129)
331158	IN	SKODA 9 (→ 1037), 11 (→ 1037), ... , 14 (→ 1038), 15 (→ 1038) VOLKSWAGEN 18 (→ 1129), 19 (→ 1129), ... , 27 (→ 1131), 317 (→ 1252)
331159	EX	SKODA 11 (→ 1037), 12 (→ 1038) VOLKSWAGEN 19 (→ 1129), 22 (→ 1130), 23 (→ 1131), 317 (→ 1252)
331160	EX	SKODA 94 (→ 1076), 97 (→ 1078), 98 (→ 1078), 99 (→ 1079) VOLKSWAGEN 323 (→ 1255), 324 (→ 1255), ... , 373 (→ 1273), 375 (→ 1274)
331161	EX	SKODA 1 (→ 1035) VOLKSWAGEN 8 (→ 1126), 9 (→ 1127), 10 (→ 1127)
331162	IN	SKODA 94 (→ 1076), 95 (→ 1077), ... , 98 (→ 1078), 99 (→ 1079) VOLKSWAGEN 323 (→ 1255), 324 (→ 1255), ... , 372 (→ 1273), 373 (→ 1273)
331163	IN	SKODA 8 (→ 1037) VOLKSWAGEN 17 (→ 1129), 24 (→ 1131), 25 (→ 1131)
331164	EX	SKODA 8 (→ 1037), 9 (→ 1037), 14 (→ 1038), 15 (→ 1038) VOLKSWAGEN 17 (→ 1129), 18 (→ 1129), ... , 26 (→ 1131), 27 (→ 1131)
331165	IN	VOLKSWAGEN 292 (→ 1241)
331166	EX	VOLKSWAGEN 292 (→ 1241)
33125	IN	VOLKSWAGEN 211 (→ 1206), 296 (→ 1242)
33282	IN	VOLKSWAGEN 191 (→ 1198), 196 (→ 1200), ... , 228 (→ 1212), 229 (→ 1212)
33308	IN	VOLKSWAGEN 298 (→ 1243)
33313	IN	VOLKSWAGEN 192 (→ 1198), 208 (→ 1205), ... , 299 (→ 1244), 300 (→ 1244)
33394	EX	SKODA 66 (→ 1063), 67 (→ 1063), 68 (→ 1064), 71 (→ 1065) VOLKSWAGEN 239 (→ 1217), 243 (→ 1219), ... , 250 (→ 1221), 251 (→ 1221)
33403	IN	SKODA 65 (→ 1062), 84 (→ 1071), 85 (→ 1072), 86 (→ 1072) VOLKSWAGEN 221 (→ 1209), 232 (→ 1214), ... , 345 (→ 1263), 346 (→ 1263)
33413	IN	SKODA 64 (→ 1062), 66 (→ 1063), ... , 71 (→ 1065), 87 (→ 1072) VOLKSWAGEN 237 (→ 1216), 239 (→ 1217), ... , 251 (→ 1221), 302 (→ 1245)
33416	EX	SKODA 65 (→ 1062), 84 (→ 1071), 85 (→ 1072), 86 (→ 1072) VOLKSWAGEN 221 (→ 1209), 222 (→ 1210), ... , 345 (→ 1263), 346 (→ 1263)
33463	IN	VOLKSWAGEN 122 (→ 1167)
390058	IN	VOLKSWAGEN 39 (→ 1135), 42 (→ 1136)
3911	EX	VOLKSWAGEN 397 (→ 1279), 398 (→ 1280)

Item No.	Type	Pos (→  )
39112	IN	VOLKSWAGEN 397 (→ 1279), 398 (→ 1280)
39123	IN	SKODA 40 (→ 1051), 43 (→ 1052)
		VOLKSWAGEN 48 (→ 1137), 100 (→ 1159), ... , 154 (→ 1181), 155 (→ 1181)
39136	IN	VOLKSWAGEN 191 (→ 1198), 193 (→ 1199), ... , 205 (→ 1204), 209 (→ 1205)
39143	IN	VOLKSWAGEN 100 (→ 1159), 111 (→ 1164), ... , 139 (→ 1174), 141 (→ 1176)
39183	IN	VOLKSWAGEN 102 (→ 1160), 105 (→ 1162), 106 (→ 1162), 107 (→ 1163)
39185	EX	SKODA 40 (→ 1051), 43 (→ 1052)
		VOLKSWAGEN 48 (→ 1137), 134 (→ 1171), ... , 154 (→ 1181), 155 (→ 1181)
39262	IN	VOLKSWAGEN 43 (→ 1136), 44 (→ 1136)
39300	EX	MERCEDES-BENZ 15 (→ 500)
		VOLKSWAGEN 238 (→ 1216), 294 (→ 1242)
39360	IN	VOLKSWAGEN 41 (→ 1135), 44 (→ 1136)
39367	IN	VOLKSWAGEN 50 (→ 1138)
39372	IN	MERCEDES-BENZ 15 (→ 500)
		VOLKSWAGEN 238 (→ 1216), 294 (→ 1242)
39395	IN	SKODA 40 (→ 1051)
		VOLKSWAGEN 134 (→ 1171), 137 (→ 1173), ... , 144 (→ 1177), 168 (→ 1187)
39423	IN	FORD 44 (→ 306)
		VOLKSWAGEN 138 (→ 1174), 140 (→ 1175), ... , 282 (→ 1237), 283 (→ 1238)
		VOLVO 23 (→ 1342)
39467	EX	SKODA 18 (→ 1039)
		VOLKSWAGEN 49 (→ 1138), 50 (→ 1138), ... , 52 (→ 1138), 53 (→ 1139)
39474	EX	SKODA 40 (→ 1051)
		VOLKSWAGEN 134 (→ 1171), 137 (→ 1173), ... , 144 (→ 1177), 168 (→ 1187)
39486	IN	FORD 44 (→ 306), 45 (→ 306)
		SKODA 41 (→ 1051), 42 (→ 1051)
		VOLKSWAGEN 138 (→ 1174), 140 (→ 1175), ... , 164 (→ 1186), 187 (→ 1196)
39502	IN	SKODA 40 (→ 1051), 43 (→ 1052), 44 (→ 1052)
		VOLKSWAGEN 144 (→ 1177), 145 (→ 1177), ... , 167 (→ 1187), 188 (→ 1197)
39503	EX	SKODA 40 (→ 1051), 43 (→ 1052), 44 (→ 1052)
		VOLKSWAGEN 144 (→ 1177), 145 (→ 1177), ... , 167 (→ 1187), 188 (→ 1197)
39515	EX	VOLKSWAGEN 1 (→ 1125)
39522	IN	SKODA 19 (→ 1039), 20 (→ 1040), ... , 34 (→ 1048), 36 (→ 1049)
		VOLKSWAGEN 56 (→ 1140), 57 (→ 1141), ... , 88 (→ 1157), 91 (→ 1157)
39523	EX	SKODA 19 (→ 1039), 20 (→ 1040), ... , 34 (→ 1048), 36 (→ 1049)
		VOLKSWAGEN 56 (→ 1140), 57 (→ 1141), ... , 88 (→ 1157), 91 (→ 1157)
39530	IN	SKODA 18 (→ 1039)
		VOLKSWAGEN 49 (→ 1138), 52 (→ 1138), 53 (→ 1139)
39542	IN	VOLKSWAGEN 1 (→ 1125)
398000	IN	SKODA 10 (→ 1037), 13 (→ 1038), 16 (→ 1038), 37 (→ 1049)
		VOLKSWAGEN 20 (→ 1130), 21 (→ 1130), 28 (→ 1132), 92 (→ 1158)
398001	EX	SKODA 10 (→ 1037), 13 (→ 1038), 16 (→ 1038), 37 (→ 1049)
		VOLKSWAGEN 20 (→ 1130), 21 (→ 1130), 28 (→ 1132), 92 (→ 1158)
425351	EX	RENAULT 111 (→ 1014), 114 (→ 1015)
471200	IN	VOLVO 27 (→ 1343), 38 (→ 1347), 47 (→ 1349)
471202	IN	VOLVO 28 (→ 1344)
471203	EX	VOLVO 28 (→ 1344)
471204	IN	VOLVO 24 (→ 1343), 25 (→ 1343), 26 (→ 1343)
471205	EX	VOLVO 24 (→ 1343), 25 (→ 1343), 26 (→ 1343)
471206	IN	FORD 67 (→ 312), 68 (→ 312), 76 (→ 315)
		VOLVO 20 (→ 1341), 21 (→ 1342), ... , 40 (→ 1347), 41 (→ 1348)
471207	IN	FORD 67 (→ 312), 68 (→ 312), 76 (→ 315)
		VOLVO 20 (→ 1341), 21 (→ 1342), ... , 40 (→ 1347), 41 (→ 1348)
471209	EX	FORD 67 (→ 312), 68 (→ 312), 76 (→ 315)
		VOLVO 20 (→ 1341), 21 (→ 1342), ... , 40 (→ 1347), 41 (→ 1348)
471210	EX	VOLVO 27 (→ 1343), 38 (→ 1347), 47 (→ 1349)
47130	EX	RENAULT 72 (→ 1002)
		VOLVO 16 (→ 1340), 17 (→ 1341), ... , 38 (→ 1347), 40 (→ 1347)
47145	IN	RENAULT 72 (→ 1002)
		VOLVO 16 (→ 1340), 17 (→ 1341), ... , 38 (→ 1347), 40 (→ 1347)
4717	IN	VOLVO 44 (→ 1348), 51 (→ 1350), 57 (→ 1352), 62 (→ 1353)
4718	EX	VOLVO 44 (→ 1348), 51 (→ 1350), 57 (→ 1352), 62 (→ 1353)



Item No.	Type		Pos (→  )
4729	IN	VOLVO	64 (→ 1354)
4730	EX	VOLVO	64 (→ 1354)
48114	IN	VOLVO	66 (→ 1355), 69 (→ 1355)
48115	EX	VOLVO	66 (→ 1355), 69 (→ 1355)
48151	EX	VOLVO	103 (→ 1371), 104 (→ 1372), ... , 109 (→ 1376), 111 (→ 1377)
48207	IN	VOLVO	75 (→ 1358)
48208	EX	VOLVO	75 (→ 1358)
48225	IN	VOLVO	136 (→ 1391), 141 (→ 1395), 145 (→ 1397)
48227	EX	VOLVO	136 (→ 1391), 141 (→ 1395), 145 (→ 1397), 148 (→ 1399)
48256	EX	VOLVO	173 (→ 1414), 175 (→ 1415)
48260	IN	VOLVO	173 (→ 1414), 175 (→ 1415)
48300	EX	VOLVO	103 (→ 1371), 104 (→ 1372), ... , 109 (→ 1376), 111 (→ 1377)
48302	EX	VOLVO	71 (→ 1356), 72 (→ 1357)
48303	EX	VOLVO	121 (→ 1383), 122 (→ 1384), ... , 134 (→ 1390), 135 (→ 1390)
48308	IN	VOLVO	94 (→ 1366), 95 (→ 1366), 97 (→ 1368), 101 (→ 1370)
48309	EX	VOLVO	94 (→ 1366), 95 (→ 1366), 97 (→ 1368), 101 (→ 1370)
48310	IN	VOLVO	93 (→ 1365), 94 (→ 1366), ... , 99 (→ 1369), 101 (→ 1370)
48311	EX	VOLVO	94 (→ 1366), 95 (→ 1366), 96 (→ 1367), 101 (→ 1370)
48312	EX	VOLVO	93 (→ 1365), 99 (→ 1369)
48313	IN	RENAULT	122 (→ 1017), 123 (→ 1018)
		VOLVO	55 (→ 1351), 113 (→ 1378), ... , 116 (→ 1381), 120 (→ 1383)
48314	EX	RENAULT	122 (→ 1017), 123 (→ 1018)
		VOLVO	55 (→ 1351), 98 (→ 1368), ... , 116 (→ 1381), 120 (→ 1383)
48315	IN	RENAULT	126 (→ 1018), 127 (→ 1019)
		VOLVO	150 (→ 1400), 151 (→ 1402), ... , 171 (→ 1413), 172 (→ 1414)
48316	EX	RENAULT	126 (→ 1018), 127 (→ 1019)
		VOLVO	150 (→ 1400), 151 (→ 1402), ... , 171 (→ 1413), 172 (→ 1414)
48317	IN	VOLVO	177 (→ 1416)
48319	IN	VOLVO	177 (→ 1416), 178 (→ 1416), ... , 180 (→ 1417), 182 (→ 1418)
48322	IN	VOLVO	74 (→ 1358), 79 (→ 1359), 80 (→ 1359)
48324	IN	VOLVO	109 (→ 1376), 111 (→ 1377)
48325	EX	VOLVO	75 (→ 1358)
48326	EX	VOLVO	74 (→ 1358), 79 (→ 1359)
48327	IN	VOLVO	137 (→ 1392), 138 (→ 1392), ... , 145 (→ 1397), 148 (→ 1399)
48328	EX	VOLVO	137 (→ 1392), 138 (→ 1392), ... , 140 (→ 1394), 142 (→ 1396)
48330	EX	VOLVO	177 (→ 1416), 178 (→ 1416), ... , 180 (→ 1417), 182 (→ 1418)
48335	IN	VOLVO	91 (→ 1364)
48336	EX	VOLVO	91 (→ 1364)
48337	EX	VOLVO	156 (→ 1405), 162 (→ 1409)
4906	IN	VOLKSWAGEN	99 (→ 1159), 104 (→ 1161), ... , 110 (→ 1164), 113 (→ 1165)
50 004 282	IN	FIAT	119 (→ 250), 127 (→ 252), 133 (→ 254)
50 004 664	EX	MERCEDES-BENZ	413 (→ 760), 414 (→ 761)
50 004 665	EX	MERCEDES-BENZ	372 (→ 715), 388 (→ 736), ... , 505 (→ 854), 506 (→ 855)
50 009 050	IN	FIAT	139 (→ 257)
50 009 053	EX	MERCEDES-BENZ	238 (→ 615), 239 (→ 616), ... , 307 (→ 659), 308 (→ 660)
510201	IN	RENAULT	60 (→ 998), 61 (→ 999)
		VOLVO	31 (→ 1344)
510202	EX	RENAULT	60 (→ 998), 61 (→ 999)
		VOLVO	31 (→ 1344)
511011	IN	RENAULT	62 (→ 999), 70 (→ 1001)
511012	EX	RENAULT	62 (→ 999), 70 (→ 1001)
511013	IN	NISSAN	17 (→ 934)
		RENAULT	46 (→ 993), 48 (→ 994), ... , 51 (→ 996), 55 (→ 997)
		VOLVO	13 (→ 1339)
511014	EX	NISSAN	17 (→ 934)
		RENAULT	46 (→ 993), 48 (→ 994), ... , 51 (→ 996), 55 (→ 997)
		VOLVO	13 (→ 1339)
511017	IN	RENAULT	16 (→ 981), 32 (→ 988)
511018	EX	RENAULT	16 (→ 981), 32 (→ 988)
511019	IN	NISSAN	1 (→ 929)
		RENAULT	4 (→ 976)
511020	EX	NISSAN	1 (→ 929)



Item No.	Type	Pos (→  )
		RENAULT 4 (→ 976)
515319	IN	RENAULT 89 (→ 1007)
517981	EX	RENAULT 56 (→ 998), 57 (→ 998)
		VOLVO 14 (→ 1339), 15 (→ 1340), 30 (→ 1344)
531003	IN	FIAT 78 (→ 236), 79 (→ 237)
		LANCIA 37 (→ 360)
531004	EX	FIAT 78 (→ 236), 79 (→ 237)
		LANCIA 37 (→ 360)
531005	IN	FIAT 66 (→ 233)
		ROVER 11 (→ 1024)
531010	IN	FIAT 74 (→ 235)
		LANCIA 35 (→ 360)
531011	EX	FIAT 74 (→ 235)
		LANCIA 35 (→ 360)
531031	IN	NISSAN 13 (→ 933)
		RENAULT 33 (→ 988), 34 (→ 989), ... , 38 (→ 990), 39 (→ 991)
531032	EX	NISSAN 13 (→ 933)
		RENAULT 33 (→ 988), 34 (→ 989), ... , 38 (→ 990), 39 (→ 991)
533033	EX	FIAT 87 (→ 239)
536226	IN	RENAULT 95 (→ 1010), 97 (→ 1010)
		VOLVO 49 (→ 1349), 56 (→ 1351)
536766	IN	FORD 143 (→ 343)
537006	IN	FIAT 87 (→ 239)
537131	IN	FIAT 87 (→ 239)
537132	EX	FIAT 87 (→ 239)
537148	EX	FORD 71 (→ 313)
537450	EX	FIAT 66 (→ 233), 67 (→ 233)
		ROVER 11 (→ 1024)
537627	IN	FORD 56 (→ 309)
		ROVER 9 (→ 1024)
537628	EX	FORD 56 (→ 309)
		ROVER 9 (→ 1024)
537746	IN	FIAT 59 (→ 231), 67 (→ 233), 68 (→ 234)
537747	EX	FIAT 59 (→ 231), 66 (→ 233), 67 (→ 233), 68 (→ 234)
537851	EX	FIAT 64 (→ 232)
537853	IN	FIAT 64 (→ 232)
538930	EX	RENAULT 95 (→ 1010), 97 (→ 1010)
		VOLVO 49 (→ 1349), 56 (→ 1351)
539009	IN	FIAT 25 (→ 223)
		FORD 20 (→ 298), 21 (→ 298), 22 (→ 299)
		VOLVO 3 (→ 1337)
539010	EX	FIAT 25 (→ 223)
		FORD 20 (→ 298), 21 (→ 298), 22 (→ 299)
		VOLVO 3 (→ 1337)
539011	IN	NISSAN 19 (→ 935), 20 (→ 935)
		RENAULT 65 (→ 1000), 67 (→ 1000), ... , 69 (→ 1001), 71 (→ 1002)
539014	EX	NISSAN 19 (→ 935), 20 (→ 935)
		RENAULT 65 (→ 1000), 67 (→ 1000), ... , 69 (→ 1001), 71 (→ 1002)
539017	EX	MERCEDES-BENZ 6 (→ 498)
		NISSAN 6 (→ 931), 7 (→ 932), 8 (→ 932)
		RENAULT 18 (→ 982), 19 (→ 983), ... , 26 (→ 986), 27 (→ 986)
539018	IN	MERCEDES-BENZ 6 (→ 498)
		NISSAN 6 (→ 931), 7 (→ 932), 8 (→ 932)
		RENAULT 18 (→ 982), 19 (→ 983), ... , 26 (→ 986), 27 (→ 986)
539020	IN	NISSAN 38 (→ 939), 41 (→ 940)
		RENAULT 94 (→ 1009), 96 (→ 1010)
539021	EX	NISSAN 38 (→ 939), 41 (→ 940)
		RENAULT 94 (→ 1009), 96 (→ 1010)
539022	IN	FIAT 96 (→ 241)
		LANCIA 48 (→ 363)
539023	EX	FIAT 96 (→ 241)
		LANCIA 48 (→ 363)

Item No.	Type	Pos ( →  )
539024	IN	NISSAN 24 (→ 936), 25 (→ 936), 26 (→ 936), 32 (→ 937) RENAULT 73 (→ 1002), 74 (→ 1003), ... , 86 (→ 1006), 88 (→ 1007)
539025	EX	NISSAN 24 (→ 936), 25 (→ 936), 26 (→ 936), 32 (→ 937) RENAULT 73 (→ 1002), 74 (→ 1003), ... , 86 (→ 1006), 88 (→ 1007)
539028	IN	NISSAN 2 (→ 929) RENAULT 3 (→ 976), 5 (→ 977), 6 (→ 977)
539029	EX	NISSAN 2 (→ 929) RENAULT 3 (→ 976), 5 (→ 977), 6 (→ 977)
539031	EX	BMW 5 (→ 165)
539044	IN	FIAT 39 (→ 225) MERCEDES-BENZ 13 (→ 500) NISSAN 18 (→ 934) RENAULT 52 (→ 996), 53 (→ 996)
539045	EX	FIAT 39 (→ 225) MERCEDES-BENZ 13 (→ 500) NISSAN 18 (→ 934) RENAULT 52 (→ 996), 53 (→ 996)
539046	IN	FIAT 26 (→ 223) FORD 11 (→ 295), 12 (→ 296), ... , 25 (→ 300), 26 (→ 301) VOLVO 4 (→ 1337)
539047	EX	FIAT 26 (→ 223) FORD 11 (→ 295), 12 (→ 296), ... , 25 (→ 300), 26 (→ 301) VOLVO 4 (→ 1337)
539048	IN	NISSAN 5 (→ 930) RENAULT 10 (→ 978), 11 (→ 979)
539050	IN	FIAT 80 (→ 237), 82 (→ 238), 83 (→ 238) FORD 90 (→ 319), 97 (→ 323) LANCIA 39 (→ 361), 41 (→ 361), 43 (→ 362)
539051	EX	FIAT 80 (→ 237), 82 (→ 238), 83 (→ 238) FORD 90 (→ 319), 97 (→ 323) LANCIA 39 (→ 361), 41 (→ 361), 43 (→ 362)
539052	EX	NISSAN 5 (→ 930) RENAULT 10 (→ 978), 11 (→ 979)
560017	IN	FIAT 65 (→ 233)
560018	EX	FIAT 65 (→ 233)
59108	IN	RENAULT 115 (→ 1015)
59109	EX	RENAULT 115 (→ 1015)
595915	EX	RENAULT 128 (→ 1019)
597673	IN	RENAULT 111 (→ 1014), 114 (→ 1015)
598141	EX	RENAULT 121 (→ 1017), 124 (→ 1018)
598142	IN	RENAULT 121 (→ 1017), 124 (→ 1018)
598349	IN	RENAULT 128 (→ 1019)
701007	IN	NISSAN 34 (→ 938)
701030	IN	NISSAN 35 (→ 938), 36 (→ 938), ... , 39 (→ 939), 43 (→ 940)
701031	EX	NISSAN 35 (→ 938), 36 (→ 938), ... , 39 (→ 939), 43 (→ 940)
701032	IN	NISSAN 12 (→ 933)
701033	EX	NISSAN 12 (→ 933)
701034	IN	NISSAN 15 (→ 934)
701035	EX	NISSAN 15 (→ 934)
7837	IN	FORD 78 (→ 315), 100 (→ 323), ... , 136 (→ 341), 137 (→ 342)
7885	EX	FORD 78 (→ 315), 100 (→ 323), ... , 136 (→ 341), 137 (→ 342)
S3438	EX	FORD 86 (→ 317)
V3816	IN	ROVER 2 (→ 1023), 4 (→ 1023), 17 (→ 1025)
KK-10H		FIAT 144 (→ 258) FORD 159 (→ 346), 160 (→ 346) RENAULT 111 (→ 1014), 114 (→ 1015), 115 (→ 1015)
KK-11H		FIAT 145 (→ 259)
KK-12H		RENAULT 128 (→ 1020)
KK-6H		FIAT 74 (→ 235) LANCIA 35 (→ 360)

Item No.	Type	Pos (→  )
		MERCEDES-BENZ 30 (→ 505)
KK-7H		FORD 56 (→ 309)
		NISSAN 17 (→ 934)
		RENAULT 1 (→ 976), 2 (→ 976), ... , 62 (→ 999), 70 (→ 1001)
		ROVER 7 (→ 1023), 9 (→ 1024)
		VOLVO 1 (→ 1337), 2 (→ 1337), ... , 15 (→ 1340), 30 (→ 1344)
KK-8H		FIAT 59 (→ 231), 64 (→ 232), ... , 140 (→ 257), 141 (→ 257)
		FORD 120 (→ 334), 143 (→ 343), 144 (→ 343)
		RENAULT 30 (→ 987), 40 (→ 991), ... , 95 (→ 1010), 97 (→ 1010)
		ROVER 11 (→ 1024)
		VOLVO 8 (→ 1338), 12 (→ 1339), ... , 56 (→ 1351), 91 (→ 1364)
KK-9H		FIAT 137 (→ 256), 138 (→ 256), 143 (→ 258)
		FORD 161 (→ 346)
		MERCEDES-BENZ 230 (→ 611)
LK-1605		MERCEDES-BENZ 315 (→ 663), 322 (→ 666), ... , 397 (→ 745), 475 (→ 824)
LK-1610		MERCEDES-BENZ 315 (→ 663), 322 (→ 666), ... , 509 (→ 859), 541 (→ 902)
LK-2607		MERCEDES-BENZ 21 (→ 502), 47 (→ 512), 95 (→ 535), 127 (→ 545)
LK-2615		MERCEDES-BENZ 437 (→ 788), 440 (→ 791), ... , 554 (→ 913), 555 (→ 914)
LK-5.5H		NISSAN 13 (→ 933)
		RENAULT 33 (→ 988), 34 (→ 989), ... , 38 (→ 990), 39 (→ 991)
LK-6H		FIAT 87 (→ 239), 96 (→ 241)
		LANCIA 48 (→ 363)
		MERCEDES-BENZ 56 (→ 515), 65 (→ 520), ... , 75 (→ 524), 86 (→ 531)
LK-7H		MERCEDES-BENZ 65 (→ 520), 86 (→ 531)
MK-10H		FORD 159 (→ 346), 160 (→ 346)
MK-5.5H		FIAT 25 (→ 223), 26 (→ 223)
		FORD 10 (→ 294), 11 (→ 295), ... , 25 (→ 300), 26 (→ 301)
		NISSAN 2 (→ 929), 5 (→ 930)
		RENAULT 3 (→ 976), 5 (→ 977), ... , 10 (→ 979), 11 (→ 979)
		VOLVO 3 (→ 1337), 4 (→ 1337)
MK-5H		BMW 5 (→ 165), 6 (→ 166), ... , 73 (→ 189), 74 (→ 189)
		FIAT 19 (→ 222), 20 (→ 222), ... , 57 (→ 231), 69 (→ 234)
		FORD 4 (→ 292)
		LANCIA 10 (→ 354), 14 (→ 354), ... , 24 (→ 357), 30 (→ 359)
		SKODA 2 (→ 1035), 3 (→ 1035), ... , 16 (→ 1038), 37 (→ 1049)
		VOLKSWAGEN 11 (→ 1127), 12 (→ 1128), ... , 292 (→ 1242), 317 (→ 1252)
MK-6H		BMW 9 (→ 166), 10 (→ 167), ... , 90 (→ 193), 91 (→ 194)
		FIAT 7 (→ 219), 8 (→ 219), ... , 124 (→ 251), 125 (→ 251)
		FORD 2 (→ 292), 6 (→ 293), ... , 94 (→ 321), 97 (→ 323)
		LANCIA 3 (→ 352), 4 (→ 352), ... , 42 (→ 362), 43 (→ 362)
		MERCEDES-BENZ 6 (→ 498), 8 (→ 499), ... , 115 (→ 541), 116 (→ 541)
		NISSAN 6 (→ 931), 7 (→ 932), ... , 26 (→ 936), 32 (→ 937)
		RENAULT 18 (→ 982), 19 (→ 983), ... , 86 (→ 1007), 88 (→ 1007)
		ROVER 13 (→ 1024)
		SKODA 19 (→ 1039), 20 (→ 1040), ... , 101 (→ 1079), 102 (→ 1080)
		VOLKSWAGEN 8 (→ 1126), 45 (→ 1136), ... , 387 (→ 1277), 388 (→ 1277)
		VOLVO 9 (→ 1339), 20 (→ 1341), ... , 45 (→ 1348), 47 (→ 1349)
MK-7H		BMW 8 (→ 166), 9 (→ 166), ... , 76 (→ 190), 93 (→ 194)
		FIAT 45 (→ 227), 46 (→ 227), ... , 65 (→ 233), 87 (→ 239)
		FORD 44 (→ 306), 45 (→ 306), ... , 133 (→ 340), 136 (→ 341)
		LANCIA 17 (→ 355), 19 (→ 356), ... , 21 (→ 356), 29 (→ 358)
		MERCEDES-BENZ 15 (→ 500), 52 (→ 513), ... , 104 (→ 538), 105 (→ 538)
		RENAULT 72 (→ 1002), 90 (→ 1008), ... , 92 (→ 1008), 93 (→ 1008)
		SKODA 17 (→ 1039), 18 (→ 1039), ... , 85 (→ 1072), 86 (→ 1072)
		VOLKSWAGEN 1 (→ 1125), 40 (→ 1135), ... , 346 (→ 1263), 404 (→ 1281)
		VOLVO 16 (→ 1340), 17 (→ 1341), ... , 54 (→ 1350), 64 (→ 1354)
MK-7H2		RENAULT 1 (→ 976), 2 (→ 976), ... , 15 (→ 981), 17 (→ 982)
		VOLVO 1 (→ 1337), 2 (→ 1337), 5 (→ 1338)
MK-8H		BMW 4 (→ 165), 29 (→ 173), ... , 95 (→ 194), 96 (→ 195)
		FIAT 50 (→ 228), 51 (→ 228), ... , 86 (→ 239), 106 (→ 244)
		FORD 17 (→ 297), 33 (→ 302), ... , 136 (→ 341), 137 (→ 342)
		LANCIA 22 (→ 357), 23 (→ 357), 25 (→ 358), 36 (→ 360)

Item No.	Type	Pos ( →  )	
		RENAULT	122 (→ 1017), 123 (→ 1018), 126 (→ 1018), 127 (→ 1019)
		SKODA	40 (→ 1051), 43 (→ 1052)
		VOLKSWAGEN	29 (→ 1132), 30 (→ 1132), ... , 397 (→ 1279), 398 (→ 1280)
		VOLVO	6 (→ 1338), 7 (→ 1338), ... , 171 (→ 1413), 172 (→ 1414)
MK-9H		FIAT	106 (→ 244)
		FORD	140 (→ 342), 141 (→ 342), 142 (→ 343)
		RENAULT	108 (→ 1014), 109 (→ 1014), ... , 119 (→ 1016), 120 (→ 1017)
		VOLKSWAGEN	118 (→ 1167), 119 (→ 1167), ... , 397 (→ 1279), 398 (→ 1280)
		VOLVO	84 (→ 1361), 85 (→ 1362), 87 (→ 1362), 90 (→ 1364)
RK-10H		VOLVO	177 (→ 1416), 178 (→ 1416), ... , 180 (→ 1417), 182 (→ 1418)
RK-11H		VOLVO	71 (→ 1356), 72 (→ 1357), ... , 126 (→ 1387), 135 (→ 1390)
RK-7		FIAT	1 (→ 218), 2 (→ 218), ... , 93 (→ 241), 94 (→ 241)
		LANCIA	1 (→ 352), 2 (→ 352), ... , 46 (→ 363), 47 (→ 363)
		MERCEDES-BENZ	81 (→ 527), 120 (→ 543), 121 (→ 543)
RK-7H		FIAT	72 (→ 235), 130 (→ 253), 131 (→ 253)
		FORD	152 (→ 345), 153 (→ 345)
		LANCIA	33 (→ 359), 34 (→ 359)
		MERCEDES-BENZ	77 (→ 525), 81 (→ 527), ... , 105 (→ 538), 250 (→ 624)
		NISSAN	44 (→ 940)
		VOLKSWAGEN	211 (→ 1206), 296 (→ 1242), 390 (→ 1278), 403 (→ 1281)
RK-8		FIAT	2 (→ 218), 27 (→ 223), ... , 117 (→ 249), 118 (→ 249)
		LANCIA	16 (→ 355), 27 (→ 358), ... , 52 (→ 364), 53 (→ 364)
		MERCEDES-BENZ	77 (→ 525)
		RENAULT	98 (→ 1010), 99 (→ 1011), ... , 106 (→ 1013), 107 (→ 1013)
		VOLKSWAGEN	7 (→ 1126), 32 (→ 1133), ... , 102 (→ 1160), 103 (→ 1161)
		VOLVO	6 (→ 1338), 66 (→ 1355), 69 (→ 1355)
RK-8H		FIAT	98 (→ 242), 101 (→ 243), ... , 133 (→ 254), 134 (→ 254)
		LANCIA	52 (→ 364), 53 (→ 364)
		MERCEDES-BENZ	28 (→ 505), 60 (→ 516), ... , 312 (→ 662), 313 (→ 662)
		RENAULT	98 (→ 1010), 99 (→ 1011), ... , 106 (→ 1013), 107 (→ 1013)
		VOLVO	66 (→ 1355), 69 (→ 1355), ... , 145 (→ 1397), 148 (→ 1399)
RK-9.5H		MERCEDES-BENZ	341 (→ 691), 351 (→ 701), ... , 567 (→ 918), 570 (→ 919)
		VOLVO	173 (→ 1414), 175 (→ 1415)
RK-9H		MERCEDES-BENZ	16 (→ 500), 20 (→ 502), ... , 317 (→ 665), 318 (→ 665)
81-11101	IN/EX	BMW	9 (→ 166), 10 (→ 167), ... , 69 (→ 187), 76 (→ 190)
81-11102	IN/EX	BMW	32 (→ 173), 35 (→ 174), ... , 69 (→ 187), 76 (→ 190)
81-11103	IN	BMW	17 (→ 169), 19 (→ 170), 20 (→ 170), 21 (→ 170)
81-11104	EX	BMW	17 (→ 169), 19 (→ 170), 20 (→ 170), 21 (→ 170)
81-11106	IN	BMW	1 (→ 165)
81-11108	EX	BMW	17 (→ 169), 19 (→ 170), 20 (→ 170), 21 (→ 170)
81-11109	IN/EX	BMW	29 (→ 173), 85 (→ 192), 95 (→ 194), 96 (→ 195)
81-11110	IN/EX	BMW	9 (→ 166), 10 (→ 167), ... , 69 (→ 187), 76 (→ 190)
81-11111	IN/EX	BMW	32 (→ 173), 35 (→ 174), ... , 69 (→ 187), 76 (→ 190)
81-11112	IN/EX	BMW	9 (→ 166), 10 (→ 167), ... , 87 (→ 193), 90 (→ 193)
		MERCEDES-BENZ	17 (→ 501), 18 (→ 501), 24 (→ 504), 25 (→ 504)
81-11113	IN/EX	BMW	9 (→ 166), 10 (→ 167), ... , 87 (→ 193), 90 (→ 193)
81-11114	IN/EX	BMW	15 (→ 168), 18 (→ 169), ... , 20 (→ 170), 21 (→ 170)
81-11115	IN/EX	BMW	15 (→ 168), 18 (→ 169), ... , 20 (→ 170), 21 (→ 170)
81-11116	IN/EX	BMW	16 (→ 169), 59 (→ 184), ... , 67 (→ 187), 68 (→ 187)
		ROVER	12 (→ 1024), 13 (→ 1024)
81-11117	IN/EX	BMW	23 (→ 171), 42 (→ 177), ... , 88 (→ 193), 91 (→ 194)
81-11118	IN/EX	BMW	23 (→ 171), 42 (→ 177), ... , 88 (→ 193), 91 (→ 194)
81-11119	IN/EX	BMW	6 (→ 166), 61 (→ 185), ... , 63 (→ 186), 65 (→ 186)
81-11120	IN/EX	BMW	6 (→ 166), 61 (→ 185), ... , 63 (→ 186), 65 (→ 186)
81-11121	IN	BMW	5 (→ 165)
		FORD	141 (→ 342)
81-11122	IN	BMW	5 (→ 165)
		FORD	141 (→ 342)
81-11123	EX	BMW	5 (→ 165)
		FORD	141 (→ 342)

Item No.	Type	Pos (→  )
81-11124	EX	BMW 5 (→ 165) FORD 141 (→ 342)
81-11125	IN	BMW 22 (→ 171), 24 (→ 171), ... , 73 (→ 189), 74 (→ 189)
81-11126	IN	BMW 22 (→ 171), 24 (→ 171), ... , 73 (→ 189), 74 (→ 189)
81-11127	EX	BMW 22 (→ 171), 24 (→ 171), ... , 73 (→ 189), 74 (→ 189)
81-11128	EX	BMW 22 (→ 171), 24 (→ 171), ... , 73 (→ 189), 74 (→ 189)
81-1116	IN/EX	BMW 2 (→ 165)
81-1119	IN/EX	BMW 2 (→ 165)
81-1120	IN/EX	BMW 2 (→ 165)
81-1150	EX	BMW 29 (→ 173)
81-1151	EX	BMW 29 (→ 173)
81-1152	EX	BMW 29 (→ 173)
81-1153	IN/EX	BMW 29 (→ 173), 85 (→ 192), 95 (→ 194), 96 (→ 195)
81-1154	IN/EX	BMW 29 (→ 173), 85 (→ 192), 95 (→ 194), 96 (→ 195)
81-1155	IN/EX	BMW 29 (→ 173), 85 (→ 192), 95 (→ 194), 96 (→ 195)
81-1156	IN/EX	BMW 3 (→ 165), 28 (→ 172)
81-1157	IN/EX	BMW 3 (→ 165), 28 (→ 172)
81-1158	IN/EX	BMW 8 (→ 166), 12 (→ 168), ... , 34 (→ 174), 50 (→ 180)
81-1159	IN/EX	BMW 8 (→ 166), 12 (→ 168), ... , 34 (→ 174), 50 (→ 180)
81-1160	IN/EX	BMW 8 (→ 166), 12 (→ 168), ... , 34 (→ 174), 50 (→ 180)
81-1161	IN/EX	BMW 8 (→ 166), 12 (→ 168), ... , 34 (→ 174), 50 (→ 180)
81-1162	IN/EX	BMW 33 (→ 174), 75 (→ 189), ... , 89 (→ 193), 92 (→ 194)
81-1163	IN/EX	BMW 33 (→ 174), 75 (→ 189), ... , 89 (→ 193), 92 (→ 194)
81-1164	IN/EX	BMW 33 (→ 174), 75 (→ 189), ... , 89 (→ 193), 92 (→ 194)
81-1526	IN	FIAT 106 (→ 244)
81-1609	IN	FORD 145 (→ 343)
81-16100	IN/EX	MERCEDES-BENZ 129 (→ 546), 130 (→ 547), ... , 233 (→ 613), 235 (→ 614)
81-16103	IN/EX	MERCEDES-BENZ 315 (→ 663), 322 (→ 666), ... , 509 (→ 859), 541 (→ 902)
81-16104	IN/EX	MERCEDES-BENZ 437 (→ 788), 440 (→ 791), ... , 554 (→ 913), 555 (→ 914)
81-16105	IN/EX	MERCEDES-BENZ 437 (→ 788), 440 (→ 791), ... , 554 (→ 913), 555 (→ 914)
81-16106	IN/EX	MERCEDES-BENZ 238 (→ 616), 239 (→ 616), ... , 311 (→ 661), 313 (→ 662)
81-16107	IN/EX	MERCEDES-BENZ 238 (→ 616), 239 (→ 616), ... , 311 (→ 661), 313 (→ 662)
81-16108	IN	MERCEDES-BENZ 12 (→ 500)
81-16109	EX	MERCEDES-BENZ 12 (→ 500)
81-16110	IN/EX	MERCEDES-BENZ 341 (→ 691), 342 (→ 691), ... , 570 (→ 919), 571 (→ 919)
81-1631	EX	FORD 145 (→ 343)
81-1632	EX	MERCEDES-BENZ 133 (→ 549), 141 (→ 555), ... , 161 (→ 569), 180 (→ 581)
81-1638	IN	FORD 145 (→ 343)
81-1639	EX	MERCEDES-BENZ 133 (→ 549), 141 (→ 555), ... , 168 (→ 574), 180 (→ 581)
81-1640	IN	MERCEDES-BENZ 321 (→ 665)
81-1641	EX	MERCEDES-BENZ 321 (→ 665)
81-1642	IN	MERCEDES-BENZ 359 (→ 704), 360 (→ 705), ... , 473 (→ 823), 474 (→ 824)
81-1647	IN/EX	MERCEDES-BENZ 359 (→ 704), 360 (→ 705), ... , 473 (→ 823), 474 (→ 824)
81-1648	IN/EX	MERCEDES-BENZ 315 (→ 663), 322 (→ 666), ... , 482 (→ 834), 484 (→ 835)
81-1650	IN	MERCEDES-BENZ 315 (→ 663), 322 (→ 666), ... , 482 (→ 834), 484 (→ 835)
81-1654	EX	MERCEDES-BENZ 321 (→ 665)
81-1658	EX	FORD 145 (→ 343)
81-1659	EX	MERCEDES-BENZ 129 (→ 546), 130 (→ 547), ... , 178 (→ 580), 180 (→ 581)
81-1660	EX	FORD 145 (→ 343)
81-1662	IN	MERCEDES-BENZ 129 (→ 546), 130 (→ 547), ... , 178 (→ 580), 180 (→ 581)
81-1666	IN	FORD 145 (→ 343)
81-1670	EX	MERCEDES-BENZ 126 (→ 544), 128 (→ 545), ... , 180 (→ 581), 181 (→ 582)
81-1674	IN	FORD 145 (→ 343)
81-1676	EX	MERCEDES-BENZ 128 (→ 545), 129 (→ 546), ... , 180 (→ 581), 181 (→ 582)
		FORD 145 (→ 343)
		MERCEDES-BENZ 126 (→ 544), 128 (→ 545), ... , 235 (→ 614), 236 (→ 615)
		FORD 145 (→ 343)
		MERCEDES-BENZ 126 (→ 544), 128 (→ 545), ... , 235 (→ 614), 236 (→ 615)

Item No.	Type	Pos ( →  )
81-1682	IN	MERCEDES-BENZ 60 (→ 516), 61 (→ 517), ... , 87 (→ 531), 88 (→ 532)
81-1683	IN	MERCEDES-BENZ 60 (→ 516), 61 (→ 517), ... , 87 (→ 531), 88 (→ 532)
81-1684	IN	MERCEDES-BENZ 60 (→ 516), 61 (→ 517), ... , 87 (→ 531), 88 (→ 532)
81-1685	EX	MERCEDES-BENZ 60 (→ 516), 61 (→ 517), ... , 87 (→ 531), 88 (→ 532)
81-1686	EX	MERCEDES-BENZ 60 (→ 516), 61 (→ 517), ... , 87 (→ 531), 88 (→ 532)
81-17100	IN/EX	FORD 99 (→ 323), 101 (→ 324), 133 (→ 340), 136 (→ 341)
81-17110	IN/EX	FIAT 2 (→ 218), 37 (→ 225), ... , 91 (→ 240), 92 (→ 240)
		LANCIA 27 (→ 358), 44 (→ 362), 45 (→ 362)
81-17112	IN/EX	FIAT 72 (→ 235), 73 (→ 235)
		LANCIA 33 (→ 359), 34 (→ 359)
81-17114	IN/EX	FIAT 98 (→ 242), 101 (→ 243), ... , 117 (→ 249), 118 (→ 249)
		LANCIA 52 (→ 364), 53 (→ 364)
		RENAULT 98 (→ 1010), 99 (→ 1011), ... , 106 (→ 1013), 107 (→ 1013)
81-17115	IN/EX	FIAT 98 (→ 242), 101 (→ 243), ... , 117 (→ 249), 118 (→ 249)
		LANCIA 52 (→ 364), 53 (→ 364)
		RENAULT 100 (→ 1011), 101 (→ 1012), ... , 106 (→ 1013), 107 (→ 1013)
81-17116	IN/EX	FIAT 98 (→ 242), 101 (→ 243), ... , 117 (→ 249), 118 (→ 249)
		LANCIA 52 (→ 364), 53 (→ 364)
		RENAULT 100 (→ 1011), 101 (→ 1012), ... , 106 (→ 1013), 107 (→ 1013)
81-17117	IN/EX	FIAT 119 (→ 250), 127 (→ 252), ... , 136 (→ 256), 139 (→ 257)
81-17122	IN	FIAT 42 (→ 226), 45 (→ 227), ... , 90 (→ 240), 94 (→ 241)
		LANCIA 16 (→ 355), 17 (→ 355), ... , 29 (→ 358), 46 (→ 363)
81-17123	EX	FIAT 42 (→ 226), 45 (→ 227), ... , 90 (→ 240), 94 (→ 241)
		LANCIA 16 (→ 355), 17 (→ 355), ... , 29 (→ 358), 46 (→ 363)
81-17126	IN	FIAT 145 (→ 259)
81-17127	EX	FIAT 145 (→ 259)
81-17128	IN/EX	FIAT 50 (→ 228), 51 (→ 228), 52 (→ 229), 53 (→ 229)
		LANCIA 22 (→ 357), 23 (→ 357), 25 (→ 358)
81-17129	IN/EX	FIAT 50 (→ 228), 51 (→ 228), 52 (→ 229), 53 (→ 229)
		LANCIA 22 (→ 357), 23 (→ 357), 25 (→ 358)
81-17130	IN	FIAT 140 (→ 257), 141 (→ 257)
81-17131	EX	FIAT 140 (→ 257), 141 (→ 257)
81-17132	IN	FIAT 144 (→ 258)
81-17133	EX	FIAT 144 (→ 258)
81-17134	IN	FIAT 143 (→ 258)
		FORD 161 (→ 346)
81-17135	EX	FIAT 143 (→ 258)
		FORD 161 (→ 346)
81-1729	IN/EX	FIAT 6 (→ 218)
81-1755	IN/EX	FIAT 1 (→ 218), 2 (→ 218), ... , 93 (→ 241), 94 (→ 241)
		LANCIA 1 (→ 352), 2 (→ 352), ... , 46 (→ 363), 47 (→ 363)
81-1761	IN/EX	FIAT 24 (→ 223), 30 (→ 224)
81-1762	IN	FIAT 2 (→ 218), 31 (→ 224), ... , 91 (→ 240), 92 (→ 240)
		LANCIA 27 (→ 358), 31 (→ 359), 44 (→ 362), 45 (→ 362)
81-18103	IN/EX	FORD 146 (→ 344), 149 (→ 344), 154 (→ 345)
81-18104	IN/EX	FORD 16 (→ 297), 17 (→ 297), ... , 60 (→ 310), 114 (→ 332)
81-18105	IN/EX	FORD 28 (→ 301), 29 (→ 301), ... , 85 (→ 317), 102 (→ 324)
81-18106	IN/EX	FORD 5 (→ 292), 6 (→ 293), ... , 31 (→ 302), 54 (→ 309)
81-18107	IN/EX	FORD 5 (→ 292), 6 (→ 293), ... , 31 (→ 302), 54 (→ 309)
81-18110	IN/EX	FORD 78 (→ 315), 100 (→ 323), ... , 136 (→ 341), 137 (→ 342)
81-18111	IN/EX	FIAT 25 (→ 223), 26 (→ 223)
		FORD 11 (→ 295), 12 (→ 296), ... , 25 (→ 300), 26 (→ 301)
		VOLVO 3 (→ 1337), 4 (→ 1337)
81-18112	IN/EX	FORD 90 (→ 319), 91 (→ 320), ... , 126 (→ 337), 128 (→ 339)
81-18113	IN/EX	FORD 8 (→ 294), 9 (→ 294), 24 (→ 300), 43 (→ 305)
		VOLVO 10 (→ 1339), 11 (→ 1339)
81-22110	IN/EX	VOLVO 84 (→ 1361), 85 (→ 1362), 86 (→ 1362), 87 (→ 1362)
81-22113	EX	VOLVO 83 (→ 1360), 88 (→ 1363), 89 (→ 1363)
81-22114	IN/EX	VOLVO 65 (→ 1354), 70 (→ 1356)
81-2255	IN	FORD 159 (→ 346)
81-2258	EX	FORD 159 (→ 346)
81-2260	EX	FORD 159 (→ 346)





Item No.	Type	Pos (→  )
81-25109	IN/EX	VOLKSWAGEN 404 (→ 1281)
81-25116	IN/EX	VOLKSWAGEN 404 (→ 1281)
81-2602	IN	MERCEDES-BENZ 59 (→ 516), 102 (→ 537), 103 (→ 538), 106 (→ 539)
81-2604	EX	MERCEDES-BENZ 59 (→ 516), 102 (→ 537), 103 (→ 538), 106 (→ 539)
81-26106	IN	MERCEDES-BENZ 120 (→ 543)
81-26109	EX	MERCEDES-BENZ 120 (→ 543)
81-26118	IN	MERCEDES-BENZ 66 (→ 520), 107 (→ 539), ... , 123 (→ 543), 124 (→ 544)
81-26119	IN	MERCEDES-BENZ 66 (→ 520), 107 (→ 539), ... , 123 (→ 543), 124 (→ 544)
81-2612	IN	MERCEDES-BENZ 3 (→ 497), 5 (→ 498)
81-26121	EX	MERCEDES-BENZ 66 (→ 520), 108 (→ 539), ... , 123 (→ 543), 124 (→ 544)
81-26122	EX	MERCEDES-BENZ 66 (→ 520), 108 (→ 539), ... , 123 (→ 543), 124 (→ 544)
81-26124	EX	MERCEDES-BENZ 54 (→ 514)
81-26136	EX	MERCEDES-BENZ 53 (→ 514)
81-26139	IN	MERCEDES-BENZ 121 (→ 543)
81-26142	EX	MERCEDES-BENZ 121 (→ 543)
81-26145	IN	MERCEDES-BENZ 78 (→ 526), 79 (→ 526), ... , 118 (→ 542), 119 (→ 542)
81-26148	EX	MERCEDES-BENZ 78 (→ 526), 79 (→ 526), ... , 118 (→ 542), 119 (→ 542)
81-26151	IN	MERCEDES-BENZ 28 (→ 505), 76 (→ 525)
81-26154	EX	MERCEDES-BENZ 28 (→ 505), 76 (→ 525)
81-26163	IN	MERCEDES-BENZ 77 (→ 525), 81 (→ 527), ... , 110 (→ 540), 125 (→ 544)
81-26166	EX	MERCEDES-BENZ 77 (→ 525), 90 (→ 533)
81-26172	IN/EX	MERCEDES-BENZ 10 (→ 499), 11 (→ 499), ... , 125 (→ 544), 250 (→ 624)
81-26173	IN/EX	MERCEDES-BENZ 10 (→ 499), 11 (→ 499), ... , 125 (→ 544), 250 (→ 624)
81-26175	IN	MERCEDES-BENZ 10 (→ 499), 11 (→ 499), ... , 65 (→ 520), 86 (→ 531)
81-26178	EX	MERCEDES-BENZ 65 (→ 520), 86 (→ 531)
81-26182	IN/EX	MERCEDES-BENZ 56 (→ 515), 68 (→ 521), ... , 74 (→ 524), 75 (→ 524)
81-26183	IN/EX	MERCEDES-BENZ 47 (→ 512), 95 (→ 535), 127 (→ 545)
81-26184	IN/EX	MERCEDES-BENZ 21 (→ 502), 22 (→ 503), 23 (→ 503)
81-26185	IN/EX	MERCEDES-BENZ 56 (→ 515), 68 (→ 521), ... , 74 (→ 524), 75 (→ 524)
81-26186	IN/EX	MERCEDES-BENZ 33 (→ 506), 34 (→ 506), ... , 43 (→ 511), 44 (→ 511)
81-26187	IN/EX	MERCEDES-BENZ 36 (→ 507), 38 (→ 509), 39 (→ 509), 41 (→ 510)
81-2624	EX	MERCEDES-BENZ 3 (→ 497), 5 (→ 498)
81-2628	EX	MERCEDES-BENZ 9 (→ 499), 50 (→ 513), 51 (→ 513)
81-2629	IN	MERCEDES-BENZ 9 (→ 499), 50 (→ 513), 51 (→ 513)
81-2630	EX	MERCEDES-BENZ 9 (→ 499), 50 (→ 513), 51 (→ 513)
81-2631	IN	MERCEDES-BENZ 78 (→ 526), 79 (→ 526), ... , 118 (→ 542), 119 (→ 542)
81-2632	IN	MERCEDES-BENZ 78 (→ 526), 79 (→ 526), ... , 118 (→ 542), 119 (→ 542)
81-2634	EX	MERCEDES-BENZ 78 (→ 526), 79 (→ 526), ... , 118 (→ 542), 119 (→ 542)
81-2635	EX	MERCEDES-BENZ 78 (→ 526), 79 (→ 526), ... , 118 (→ 542), 119 (→ 542)
81-2639	EX	MERCEDES-BENZ 9 (→ 499), 50 (→ 513), 51 (→ 513)
81-2640	IN	MERCEDES-BENZ 9 (→ 499), 50 (→ 513), 51 (→ 513)
81-2643	IN	MERCEDES-BENZ 9 (→ 499)
81-2652	EX	MERCEDES-BENZ 19 (→ 501)
81-2658	IN	MERCEDES-BENZ 3 (→ 497), 5 (→ 498)
81-2659	EX	MERCEDES-BENZ 16 (→ 500), 20 (→ 502), ... , 58 (→ 516), 117 (→ 541)
81-2660	EX	MERCEDES-BENZ 16 (→ 500), 20 (→ 502), ... , 58 (→ 516), 117 (→ 541)
81-2667	IN	MERCEDES-BENZ 16 (→ 500), 19 (→ 501), ... , 58 (→ 516), 117 (→ 541)
81-2668	IN	MERCEDES-BENZ 16 (→ 500), 19 (→ 501), ... , 58 (→ 516), 117 (→ 541)
81-2679	IN	MERCEDES-BENZ 53 (→ 514), 54 (→ 514)
81-2685	IN	MERCEDES-BENZ 66 (→ 520), 107 (→ 539), 108 (→ 539), 122 (→ 543)
81-2688	EX	MERCEDES-BENZ 107 (→ 539)
81-2691	IN	MERCEDES-BENZ 9 (→ 499)
81-2696	EX	MERCEDES-BENZ 54 (→ 514)
81-2706	IN/EX	RENAULT 110 (→ 1014)
81-2722	IN/EX	RENAULT 108 (→ 1014), 109 (→ 1014), ... , 119 (→ 1016), 120 (→ 1017)
81-2728	IN	RENAULT 118 (→ 1016)
81-2729	EX	RENAULT 118 (→ 1016)
81-3303	EX	VOLKSWAGEN 384 (→ 1276)
81-3310	IN/EX	FORD 44 (→ 306)
		SKODA 40 (→ 1051), 43 (→ 1052)
		VOLKSWAGEN 6 (→ 1126), 7 (→ 1126), ... , 301 (→ 1245), 303 (→ 1246)
		VOLVO 6 (→ 1338), 7 (→ 1338), 23 (→ 1342)

KS/TRW/BF No. → Application

Item No.	Type	Pos (→  )
81-33100	IN/EX	FORD 46 (→ 306), 47 (→ 307), 63 (→ 311), 64 (→ 311)
		MERCEDES-BENZ 15 (→ 500)
		SKODA 47 (→ 1054), 48 (→ 1055), 56 (→ 1059)
		VOLKSWAGEN 157 (→ 1183), 158 (→ 1183), ... , 294 (→ 1242), 296 (→ 1243)
81-33101	IN/EX	VOLKSWAGEN 298 (→ 1243)
81-33103	IN/EX	FORD 44 (→ 306), 45 (→ 306), ... , 63 (→ 311), 138 (→ 342)
		SKODA 40 (→ 1051), 41 (→ 1051), ... , 85 (→ 1072), 86 (→ 1072)
		VOLKSWAGEN 116 (→ 1166), 134 (→ 1171), ... , 346 (→ 1263), 393 (→ 1278)
81-33104	IN/EX	FORD 44 (→ 306), 45 (→ 306), ... , 47 (→ 307), 63 (→ 311)
		SKODA 40 (→ 1051), 41 (→ 1051), ... , 85 (→ 1072), 86 (→ 1072)
		VOLKSWAGEN 116 (→ 1166), 134 (→ 1171), ... , 346 (→ 1263), 393 (→ 1278)
81-33107	IN/EX	VOLKSWAGEN 29 (→ 1132), 39 (→ 1135), ... , 42 (→ 1136), 44 (→ 1136)
81-33109	IN/EX	SKODA 18 (→ 1039)
		VOLKSWAGEN 1 (→ 1125), 49 (→ 1138), ... , 52 (→ 1139), 53 (→ 1139)
81-3311	IN/EX	FORD 44 (→ 306)
		SKODA 40 (→ 1051), 43 (→ 1052)
		VOLKSWAGEN 6 (→ 1126), 7 (→ 1126), ... , 301 (→ 1245), 303 (→ 1246)
		VOLVO 6 (→ 1338), 7 (→ 1338), 23 (→ 1342)
81-33110	IN/EX	SKODA 18 (→ 1039)
		VOLKSWAGEN 1 (→ 1125), 49 (→ 1138), ... , 52 (→ 1139), 53 (→ 1139)
81-33111	IN/EX	FORD 79 (→ 316)
		SKODA 1 (→ 1035), 19 (→ 1039), ... , 95 (→ 1077), 96 (→ 1078)
		VOLKSWAGEN 2 (→ 1125), 3 (→ 1125), ... , 373 (→ 1273), 374 (→ 1274)
		VOLVO 54 (→ 1350)
81-33112	IN/EX	SKODA 38 (→ 1049), 62 (→ 1061), ... , 81 (→ 1070), 82 (→ 1071)
		VOLKSWAGEN 122 (→ 1167), 123 (→ 1168), ... , 357 (→ 1268), 360 (→ 1269)
81-33113	IN/EX	SKODA 23 (→ 1042), 63 (→ 1061), ... , 72 (→ 1066), 73 (→ 1066)
		VOLKSWAGEN 65 (→ 1145), 189 (→ 1197), ... , 256 (→ 1224), 257 (→ 1224)
81-33114	IN/EX	SKODA 63 (→ 1061), 70 (→ 1065), 72 (→ 1066), 73 (→ 1066)
		VOLKSWAGEN 189 (→ 1197), 254 (→ 1223), 256 (→ 1224), 257 (→ 1224)
81-33115	IN/EX	FORD 139 (→ 342)
		SKODA 45 (→ 1053), 46 (→ 1053), ... , 52 (→ 1057), 77 (→ 1068)
		VOLKSWAGEN 156 (→ 1182), 160 (→ 1184), ... , 271 (→ 1231), 280 (→ 1236)
81-33116	IN/EX	SKODA 57 (→ 1059), 58 (→ 1060), ... , 60 (→ 1061), 62 (→ 1061)
		VOLKSWAGEN 181 (→ 1194), 182 (→ 1195), ... , 185 (→ 1196), 288 (→ 1239)
81-33117	IN/EX	SKODA 57 (→ 1059), 58 (→ 1060), ... , 60 (→ 1061), 62 (→ 1061)
		VOLKSWAGEN 181 (→ 1194), 182 (→ 1195), ... , 185 (→ 1196), 288 (→ 1239)
81-33118	IN/EX	FORD 79 (→ 316)
		SKODA 1 (→ 1035), 2 (→ 1035), ... , 95 (→ 1077), 96 (→ 1078)
		VOLKSWAGEN 2 (→ 1125), 3 (→ 1125), ... , 373 (→ 1273), 374 (→ 1274)
		VOLVO 54 (→ 1350)
81-33119	IN	SKODA 102 (→ 1080)
		VOLKSWAGEN 364 (→ 1270), 365 (→ 1270), ... , 387 (→ 1277), 388 (→ 1277)
81-3312	IN/EX	FORD 44 (→ 306)
		SKODA 40 (→ 1051), 43 (→ 1052)
		VOLKSWAGEN 6 (→ 1126), 7 (→ 1126), ... , 301 (→ 1245), 303 (→ 1246)
		VOLVO 6 (→ 1338), 7 (→ 1338), 23 (→ 1342)
81-33120	EX	SKODA 102 (→ 1080)
		VOLKSWAGEN 364 (→ 1270), 365 (→ 1270), ... , 387 (→ 1277), 388 (→ 1277)
81-33121	IN/EX	FORD 79 (→ 316)
		SKODA 1 (→ 1035), 2 (→ 1035), ... , 95 (→ 1077), 96 (→ 1078)
		VOLKSWAGEN 2 (→ 1125), 3 (→ 1125), ... , 373 (→ 1273), 374 (→ 1274)
		VOLVO 54 (→ 1350)
81-33122	EX	FORD 79 (→ 316)
		SKODA 1 (→ 1035), 3 (→ 1035), ... , 95 (→ 1077), 96 (→ 1078)
		VOLKSWAGEN 2 (→ 1125), 3 (→ 1125), ... , 373 (→ 1273), 374 (→ 1274)
81-33123	IN	VOLVO 54 (→ 1350)
		SKODA 2 (→ 1035), 3 (→ 1035), ... , 16 (→ 1038), 37 (→ 1049)
81-33124	EX	VOLKSWAGEN 11 (→ 1127), 12 (→ 1128), ... , 28 (→ 1132), 92 (→ 1158)
		SKODA 2 (→ 1035), 3 (→ 1035), ... , 16 (→ 1038), 37 (→ 1049)
81-33125	IN/EX	VOLKSWAGEN 11 (→ 1127), 12 (→ 1128), ... , 28 (→ 1132), 92 (→ 1158)
		SKODA 73 (→ 1066)

Item No.	Type	Pos (→  )
		VOLKSWAGEN 257 (→ 1224)
81-3316	IN	VOLKSWAGEN 384 (→ 1276)
81-3319	IN/EX	VOLKSWAGEN 30 (→ 1132), 32 (→ 1133), ... , 217 (→ 1208), 258 (→ 1225)
81-3320	IN/EX	VOLKSWAGEN 30 (→ 1132), 32 (→ 1133), ... , 217 (→ 1208), 258 (→ 1225)
81-3321	IN/EX	VOLKSWAGEN 211 (→ 1206)
81-3322	IN/EX	VOLKSWAGEN 211 (→ 1206)
81-3323	IN/EX	SKODA 39 (→ 1050)
		VOLKSWAGEN 124 (→ 1169), 348 (→ 1264), ... , 361 (→ 1269), 363 (→ 1269)
81-3324	IN/EX	SKODA 39 (→ 1050)
		VOLKSWAGEN 124 (→ 1169), 348 (→ 1264), ... , 361 (→ 1269), 363 (→ 1269)
81-3907	IN	VOLKSWAGEN 117 (→ 1166), 120 (→ 1167), 376 (→ 1274), 378 (→ 1275)
81-3908	IN	VOLKSWAGEN 117 (→ 1166), 120 (→ 1167), 376 (→ 1274), 378 (→ 1275)
81-3910	EX	VOLKSWAGEN 117 (→ 1166), 120 (→ 1167), 376 (→ 1274), 378 (→ 1275)
81-3915	IN	VOLKSWAGEN 117 (→ 1166), 120 (→ 1167), 376 (→ 1274), 378 (→ 1275)
81-3916	EX	VOLKSWAGEN 117 (→ 1166), 120 (→ 1167), 376 (→ 1274), 378 (→ 1275)
81-3940	IN	VOLKSWAGEN 389 (→ 1277), 392 (→ 1278), ... , 397 (→ 1280), 398 (→ 1280)
81-3941	IN	VOLKSWAGEN 389 (→ 1277), 392 (→ 1278), ... , 397 (→ 1280), 398 (→ 1280)
81-3942	IN	VOLKSWAGEN 389 (→ 1277), 392 (→ 1278), ... , 397 (→ 1280), 398 (→ 1280)
81-3946	EX	VOLKSWAGEN 389 (→ 1277), 392 (→ 1278), ... , 397 (→ 1280), 398 (→ 1280)
81-3947	EX	VOLKSWAGEN 389 (→ 1277), 392 (→ 1278), ... , 397 (→ 1280), 398 (→ 1280)
81-3948	EX	VOLKSWAGEN 389 (→ 1277), 392 (→ 1278), ... , 397 (→ 1280), 398 (→ 1280)
81-3956	EX	VOLKSWAGEN 118 (→ 1167), 119 (→ 1167), ... , 379 (→ 1275), 380 (→ 1275)
81-3958	IN	VOLKSWAGEN 118 (→ 1167), 119 (→ 1167), ... , 379 (→ 1275), 380 (→ 1275)
81-4200	IN/EX	FORD 105 (→ 325)
		LANCIA 32 (→ 359)
81-4219	IN/EX	FIAT 43 (→ 226)
81-4220	IN/EX	FIAT 23 (→ 223), 33 (→ 224), ... , 57 (→ 231), 69 (→ 234)
		LANCIA 12 (→ 354), 14 (→ 354), ... , 26 (→ 358), 30 (→ 359)
81-4221	IN/EX	FIAT 7 (→ 219), 8 (→ 219), ... , 12 (→ 220), 13 (→ 221)
		FORD 2 (→ 292), 14 (→ 297), 15 (→ 297)
		LANCIA 3 (→ 352), 4 (→ 352)
81-4222	IN/EX	FORD 36 (→ 303)
81-47103	IN/EX	RENAULT 40 (→ 991), 41 (→ 991), ... , 63 (→ 999), 64 (→ 999)
		VOLVO 14 (→ 1339), 15 (→ 1340), 30 (→ 1344), 31 (→ 1344)
81-47104	EX	VOLVO 102 (→ 1370), 103 (→ 1371), ... , 129 (→ 1387), 135 (→ 1390)
81-47105	IN/EX	RENAULT 72 (→ 1002)
		VOLVO 9 (→ 1339), 16 (→ 1340), ... , 43 (→ 1348), 48 (→ 1349)
81-47106	IN/EX	VOLVO 66 (→ 1355), 68 (→ 1355), ... , 80 (→ 1359), 81 (→ 1360)
81-47107	IN	VOLVO 173 (→ 1414)
81-47108	EX	VOLVO 173 (→ 1414)
81-47109	IN	VOLVO 102 (→ 1370), 103 (→ 1371), ... , 129 (→ 1387), 135 (→ 1390)
81-47112	IN/EX	VOLVO 71 (→ 1356), 72 (→ 1357), 73 (→ 1357), 76 (→ 1358)
81-47113	IN/EX	VOLVO 53 (→ 1350), 54 (→ 1350), 64 (→ 1354)
81-47114	IN/EX	RENAULT 122 (→ 1017), 123 (→ 1018), 126 (→ 1019), 127 (→ 1019)
		VOLVO 55 (→ 1351), 78 (→ 1359), ... , 171 (→ 1413), 172 (→ 1414)
81-47116	IN	VOLVO 111 (→ 1377), 112 (→ 1377)
81-47117	IN	VOLVO 102 (→ 1370), 103 (→ 1371), ... , 129 (→ 1387), 135 (→ 1390)
81-47119	IN/EX	RENAULT 122 (→ 1017), 123 (→ 1018), 126 (→ 1019), 127 (→ 1019)
		VOLVO 55 (→ 1351), 78 (→ 1359), ... , 169 (→ 1412), 171 (→ 1413)
81-47120	IN/EX	VOLVO 177 (→ 1416), 178 (→ 1417), 179 (→ 1417), 182 (→ 1418)
81-47121	IN/EX	VOLVO 24 (→ 1343)
81-47123	IN/EX	VOLVO 91 (→ 1364), 92 (→ 1365)
81-47124	EX	VOLVO 102 (→ 1370), 103 (→ 1371), ... , 129 (→ 1387), 135 (→ 1390)
81-4716	IN	VOLVO 29 (→ 1344), 44 (→ 1348), ... , 62 (→ 1353), 63 (→ 1354)
81-4717	EX	VOLVO 29 (→ 1344), 44 (→ 1348), ... , 62 (→ 1353), 63 (→ 1354)
81-4719	EX	VOLVO 29 (→ 1344), 44 (→ 1348), ... , 62 (→ 1353), 63 (→ 1354)
81-51000	IN/EX	MERCEDES-BENZ 6 (→ 498)
		NISSAN 6 (→ 931), 7 (→ 932), 8 (→ 932)
		RENAULT 18 (→ 982), 19 (→ 983), ... , 27 (→ 986), 52 (→ 996)
		VOLKSWAGEN 290 (→ 1241)
81-51001	IN/EX	MERCEDES-BENZ 6 (→ 498)
		NISSAN 6 (→ 931), 7 (→ 932), 8 (→ 932)



Item No.	Type	Pos ( →  )
		RENAULT 18 (→ 982), 19 (→ 983), ... , 27 (→ 986), 52 (→ 996)
		VOLKSWAGEN 290 (→ 1241)
81-51002	IN/EX	NISSAN 24 (→ 936), 25 (→ 936), 26 (→ 936), 32 (→ 938)
		RENAULT 73 (→ 1002), 74 (→ 1003), ... , 86 (→ 1007), 88 (→ 1007)
81-51003	IN/EX	NISSAN 25 (→ 936), 26 (→ 936)
		RENAULT 73 (→ 1002), 76 (→ 1004), ... , 83 (→ 1005), 86 (→ 1007)
81-5115	IN/EX	RENAULT 1 (→ 976), 2 (→ 976), ... , 15 (→ 981), 17 (→ 982)
		VOLVO 1 (→ 1337), 2 (→ 1337), 5 (→ 1338)
81-5117	EX	RENAULT 29 (→ 987), 31 (→ 987), 56 (→ 998), 57 (→ 998)
		VOLVO 14 (→ 1339)
81-5131	IN/EX	RENAULT 58 (→ 998), 59 (→ 998)
81-5132	IN/EX	NISSAN 1 (→ 929)
		RENAULT 4 (→ 976)
81-5133	IN	RENAULT 16 (→ 981), 32 (→ 988), 91 (→ 1008)
81-5134	EX	RENAULT 16 (→ 981), 32 (→ 988), 91 (→ 1008)
81-5135	IN/EX	NISSAN 17 (→ 934)
		RENAULT 46 (→ 993), 48 (→ 994), ... , 51 (→ 996), 55 (→ 997)
		VOLVO 13 (→ 1339)
81-5136	IN/EX	NISSAN 2 (→ 929), 13 (→ 933), 19 (→ 935), 20 (→ 935)
		RENAULT 3 (→ 976), 5 (→ 977), ... , 69 (→ 1001), 71 (→ 1002)
81-5200	IN/EX	VOLVO 53 (→ 1350)
81-5303	IN/EX	FORD 120 (→ 334), 143 (→ 343), 144 (→ 343)
81-5314	IN/EX	FIAT 59 (→ 231), 66 (→ 233), 67 (→ 233), 68 (→ 234)
81-5315	IN	FIAT 64 (→ 232)
81-5316	EX	FIAT 64 (→ 232)
81-5317	IN/EX	FIAT 59 (→ 231), 66 (→ 233), 67 (→ 233), 68 (→ 234)
81-5319	IN/EX	FIAT 87 (→ 239)
81-5320	IN/EX	FIAT 59 (→ 231), 66 (→ 233), 67 (→ 233), 68 (→ 234)
81-5322	IN	FIAT 64 (→ 232)
81-5323	EX	FIAT 64 (→ 232)
81-5324	IN	FIAT 86 (→ 239)
81-5325	EX	FIAT 86 (→ 239)
81-5326	IN/EX	FIAT 59 (→ 231), 66 (→ 233), 67 (→ 233), 68 (→ 234)
		ROVER 11 (→ 1024)
81-5330	IN/EX	FIAT 75 (→ 235), 76 (→ 236), ... , 82 (→ 238), 84 (→ 238)
		FORD 87 (→ 318), 88 (→ 318), ... , 93 (→ 321), 94 (→ 321)
		LANCIA 37 (→ 360), 38 (→ 360), ... , 42 (→ 362), 43 (→ 362)
		VOLVO 45 (→ 1348)
81-5331	IN/EX	LANCIA 36 (→ 360)
81-5332	IN/EX	NISSAN 38 (→ 939), 41 (→ 940)
		RENAULT 94 (→ 1009), 96 (→ 1010)
81-5333	IN	FIAT 74 (→ 235), 87 (→ 239)
		LANCIA 35 (→ 360)
81-5334	EX	FIAT 74 (→ 235), 87 (→ 239)
		LANCIA 35 (→ 360)
81-5609	EX	FIAT 97 (→ 242)
		LANCIA 49 (→ 364), 50 (→ 364)
81-5610	EX	LANCIA 51 (→ 364)
81-5611	IN/EX	FIAT 98 (→ 242), 101 (→ 243), ... , 117 (→ 249), 118 (→ 249)
		LANCIA 52 (→ 364), 53 (→ 364)
		RENAULT 100 (→ 1011), 101 (→ 1012), ... , 106 (→ 1013), 107 (→ 1013)
81-5801	IN/EX	FORD 56 (→ 309), 69 (→ 313), ... , 74 (→ 315), 113 (→ 332)
81-59000	IN	RENAULT 111 (→ 1014), 114 (→ 1015)
81-59001	EX	RENAULT 111 (→ 1014), 114 (→ 1015)
81-59002	IN/EX	RENAULT 121 (→ 1017), 124 (→ 1018)
81-59003	IN	RENAULT 121 (→ 1017), 124 (→ 1018)
81-59004	IN/EX	RENAULT 125 (→ 1018), 128 (→ 1020)
81-59005	EX	RENAULT 121 (→ 1017), 124 (→ 1018)
81-59006	IN	RENAULT 116 (→ 1016)
81-59007	EX	RENAULT 116 (→ 1016)
81-70001	IN	NISSAN 11 (→ 933), 16 (→ 934), ... , 30 (→ 937), 31 (→ 937)
81-70002	EX	NISSAN 11 (→ 933), 16 (→ 934), ... , 30 (→ 937), 31 (→ 937)

Item No.	Type		Pos (→  )
			
81-70003	IN	NISSAN	22 (→ 935), 33 (→ 938), 34 (→ 938)
81-70004	IN	NISSAN	10 (→ 933), 12 (→ 933)
81-70005	IN	NISSAN	10 (→ 933), 12 (→ 933)
81-70006	EX	NISSAN	10 (→ 933), 12 (→ 933)
81-70007	EX	NISSAN	10 (→ 933), 12 (→ 933)
81-70008	IN	NISSAN	36 (→ 938), 37 (→ 938), 39 (→ 939), 40 (→ 940)
81-70009	EX	NISSAN	36 (→ 938), 37 (→ 938), 39 (→ 939), 40 (→ 940)
81-71002	IN/EX	VOLKSWAGEN	391 (→ 1278)
81-71003	IN/EX	FORD	40 (→ 304), 42 (→ 305)
		VOLVO	9 (→ 1339)
81-72000	EX	ROVER	4 (→ 1023), 6 (→ 1023)
81-72001	EX	ROVER	4 (→ 1023), 17 (→ 1025)
81-72003	IN	ROVER	4 (→ 1023), 6 (→ 1023)
81-73000	EX	FORD	103 (→ 324)
81-75000	IN	FORD	86 (→ 317)
81-85003	IN	FIAT	126 (→ 252), 128 (→ 253), 129 (→ 253)
		RENAULT	112 (→ 1015)
		VOLKSWAGEN	401 (→ 1281)
		VOLVO	67 (→ 1355)
81-85004	EX	FIAT	126 (→ 252), 128 (→ 253), 129 (→ 253)
		RENAULT	112 (→ 1015)
		VOLKSWAGEN	401 (→ 1281)
		VOLVO	67 (→ 1355)
81-85005	IN/EX	FIAT	32 (→ 224), 102 (→ 243), 103 (→ 243)
81-88000	IN/EX	ROVER	3 (→ 1023), 5 (→ 1023), 10 (→ 1024)
81-88003	IN/EX	ROVER	8 (→ 1023)
81-88004	IN/EX	ROVER	1 (→ 1023)
81-88005	IN/EX	ROVER	14 (→ 1024), 15 (→ 1025), 16 (→ 1025)
			
92-16100		MERCEDES-BENZ	315 (→ 663), 322 (→ 666), ... , 509 (→ 860), 541 (→ 902)
92-16101		MERCEDES-BENZ	315 (→ 663), 322 (→ 666), ... , 509 (→ 860), 541 (→ 902)
92-16104		MERCEDES-BENZ	315 (→ 663), 322 (→ 666), ... , 509 (→ 860), 541 (→ 902)
92-16105		MERCEDES-BENZ	315 (→ 663), 322 (→ 666), ... , 509 (→ 860), 541 (→ 902)
92-16106		MERCEDES-BENZ	359 (→ 704), 360 (→ 705), ... , 473 (→ 823), 474 (→ 824)
92-16109		FORD	145 (→ 343)
		MERCEDES-BENZ	126 (→ 544), 128 (→ 545), ... , 234 (→ 614), 235 (→ 614)
92-16110		MERCEDES-BENZ	359 (→ 704), 360 (→ 705), ... , 473 (→ 823), 474 (→ 824)
92-16112		FORD	145 (→ 343)
		MERCEDES-BENZ	126 (→ 544), 128 (→ 545), ... , 180 (→ 581), 181 (→ 582)
92-16114		FORD	145 (→ 343)
		MERCEDES-BENZ	126 (→ 544), 128 (→ 545), ... , 180 (→ 581), 181 (→ 582)
92-16116		MERCEDES-BENZ	143 (→ 556), 170 (→ 575), ... , 233 (→ 613), 236 (→ 615)
92-16118		MERCEDES-BENZ	366 (→ 708), 377 (→ 720)
92-16120		MERCEDES-BENZ	60 (→ 516), 61 (→ 517), ... , 83 (→ 529), 84 (→ 529)
92-16121		MERCEDES-BENZ	60 (→ 516), 61 (→ 517), ... , 83 (→ 529), 84 (→ 529)
92-16122		MERCEDES-BENZ	372 (→ 715), 407 (→ 756), ... , 444 (→ 796), 479 (→ 830)
92-16123		MERCEDES-BENZ	372 (→ 715), 407 (→ 756), ... , 444 (→ 796), 479 (→ 830)
92-16124		MERCEDES-BENZ	60 (→ 516), 61 (→ 517), ... , 83 (→ 529), 84 (→ 529)
92-16125		MERCEDES-BENZ	60 (→ 516), 61 (→ 517), ... , 83 (→ 529), 84 (→ 529)
92-16126		MERCEDES-BENZ	332 (→ 682), 334 (→ 684), ... , 485 (→ 836), 505 (→ 854)
92-16127		MERCEDES-BENZ	332 (→ 682), 334 (→ 684), ... , 485 (→ 836), 505 (→ 854)
92-16128		MERCEDES-BENZ	332 (→ 682), 334 (→ 684), ... , 485 (→ 836), 505 (→ 854)
92-16131		FORD	145 (→ 343)
		MERCEDES-BENZ	126 (→ 544), 128 (→ 545), ... , 235 (→ 614), 236 (→ 615)
92-16132		MERCEDES-BENZ	321 (→ 666)
92-16133		MERCEDES-BENZ	321 (→ 666)
92-16134		MERCEDES-BENZ	321 (→ 666)
92-16135		MERCEDES-BENZ	321 (→ 666)
92-16136		MERCEDES-BENZ	321 (→ 666)
92-16137		MERCEDES-BENZ	321 (→ 666)
92-16140		MERCEDES-BENZ	359 (→ 704), 363 (→ 707), ... , 408 (→ 756), 473 (→ 823)



Item No.	Type	Pos (→  )
92-16141	MERCEDES-BENZ	363 (→ 707), 368 (→ 709), ... , 396 (→ 744), 474 (→ 824)
92-16142	MERCEDES-BENZ	359 (→ 704), 360 (→ 705), ... , 473 (→ 823), 474 (→ 824)
92-16143	MERCEDES-BENZ	359 (→ 704), 360 (→ 705), ... , 473 (→ 823), 474 (→ 824)
92-16145	MERCEDES-BENZ	366 (→ 708), 377 (→ 720)
92-16146	MERCEDES-BENZ	366 (→ 708), 367 (→ 709), 377 (→ 720)
92-16147	MERCEDES-BENZ	315 (→ 663), 322 (→ 666), ... , 509 (→ 860), 541 (→ 902)
92-16148	MERCEDES-BENZ	315 (→ 663), 322 (→ 666), ... , 509 (→ 860), 541 (→ 902)
92-16149	MERCEDES-BENZ	332 (→ 682), 334 (→ 684), ... , 485 (→ 836), 505 (→ 854)
92-16150	MERCEDES-BENZ	362 (→ 706), 375 (→ 719), ... , 483 (→ 835), 484 (→ 835)
92-16151	MERCEDES-BENZ	332 (→ 682), 334 (→ 684), ... , 505 (→ 854), 508 (→ 859)
92-16152	MERCEDES-BENZ	332 (→ 682), 334 (→ 684), ... , 505 (→ 854), 508 (→ 859)
92-16153	MERCEDES-BENZ	143 (→ 556), 170 (→ 575), ... , 233 (→ 613), 236 (→ 615)
92-16154	MERCEDES-BENZ	185 (→ 583), 186 (→ 584), ... , 232 (→ 612), 236 (→ 615)
92-16155	MERCEDES-BENZ	165 (→ 572), 170 (→ 575), ... , 235 (→ 614), 236 (→ 615)
92-16156	MERCEDES-BENZ	437 (→ 788), 440 (→ 792), ... , 542 (→ 904), 549 (→ 910)
92-16157	MERCEDES-BENZ	437 (→ 788), 440 (→ 792), ... , 553 (→ 913), 555 (→ 914)
92-16158	MERCEDES-BENZ	437 (→ 788), 440 (→ 792), ... , 553 (→ 913), 555 (→ 914)
92-16159	MERCEDES-BENZ	238 (→ 616), 239 (→ 616), ... , 311 (→ 661), 313 (→ 662)
92-16160	MERCEDES-BENZ	238 (→ 616), 239 (→ 616), ... , 311 (→ 661), 313 (→ 662)
92-16161	MERCEDES-BENZ	354 (→ 702), 355 (→ 703), 356 (→ 703), 358 (→ 704)
92-16162	MERCEDES-BENZ	354 (→ 702), 355 (→ 703), 356 (→ 703), 358 (→ 704)
92-16163	MERCEDES-BENZ	315 (→ 663), 324 (→ 669), ... , 347 (→ 697), 348 (→ 698)
92-16165	MERCEDES-BENZ	238 (→ 616), 239 (→ 616), ... , 312 (→ 662), 313 (→ 662)
92-16166	MERCEDES-BENZ	238 (→ 616), 239 (→ 616), ... , 310 (→ 661), 313 (→ 662)
92-16167	MERCEDES-BENZ	238 (→ 616), 239 (→ 616), ... , 312 (→ 662), 313 (→ 662)
92-16170	MERCEDES-BENZ	441 (→ 793), 446 (→ 798), ... , 554 (→ 913), 555 (→ 914)
92-17000	FIAT	130 (→ 253)
	FORD	152 (→ 345), 153 (→ 345)
	NISSAN	44 (→ 941)
	VOLKSWAGEN	403 (→ 1281)
92-17001	FIAT	130 (→ 253)
	FORD	152 (→ 345), 153 (→ 345)
	NISSAN	44 (→ 941)
	VOLKSWAGEN	403 (→ 1281)
92-22005	VOLVO	84 (→ 1361), 85 (→ 1362), 86 (→ 1362), 87 (→ 1363)
92-22006	VOLVO	84 (→ 1361), 85 (→ 1362), 86 (→ 1362), 87 (→ 1363)
92-22013	VOLVO	65 (→ 1354), 70 (→ 1356)
92-22014	VOLVO	65 (→ 1354), 70 (→ 1356)
92-22017	FORD	159 (→ 346), 160 (→ 346)
92-22018	FORD	159 (→ 346), 160 (→ 346)
92-22019	VOLVO	83 (→ 1360), 88 (→ 1363), 89 (→ 1363)
92-22020	VOLVO	83 (→ 1360), 88 (→ 1363), 89 (→ 1363)
92-22021	RENAULT	118 (→ 1016)
92-22022	RENAULT	118 (→ 1016)
92-47001	VOLVO	71 (→ 1356), 72 (→ 1357), 73 (→ 1357), 76 (→ 1358)
92-47002	VOLVO	71 (→ 1356), 72 (→ 1357), 73 (→ 1357), 76 (→ 1358)
92-47003	VOLVO	71 (→ 1356), 72 (→ 1357), 73 (→ 1357), 76 (→ 1358)
92-47004	VOLVO	71 (→ 1356), 72 (→ 1357), 73 (→ 1357), 76 (→ 1358)
92-47005	VOLVO	105 (→ 1373)
92-47006	VOLVO	105 (→ 1373)
92-47007	VOLVO	121 (→ 1384), 122 (→ 1384), ... , 134 (→ 1390), 135 (→ 1390)
92-47008	VOLVO	121 (→ 1384), 122 (→ 1384), ... , 134 (→ 1390), 135 (→ 1390)
92-47009	VOLVO	121 (→ 1384), 122 (→ 1384), ... , 134 (→ 1390), 135 (→ 1390)
92-47011	VOLVO	102 (→ 1370), 103 (→ 1371), ... , 111 (→ 1377), 112 (→ 1377)
92-47012	VOLVO	102 (→ 1370), 103 (→ 1371), ... , 111 (→ 1377), 112 (→ 1377)
92-47013	VOLVO	103 (→ 1371), 104 (→ 1372), ... , 109 (→ 1376), 111 (→ 1377)
92-47015	VOLVO	102 (→ 1370), 104 (→ 1372), ... , 111 (→ 1377), 112 (→ 1377)
92-47016	VOLVO	102 (→ 1370), 104 (→ 1372), ... , 111 (→ 1377), 112 (→ 1377)
92-47019	VOLVO	58 (→ 1352), 59 (→ 1353), ... , 149 (→ 1400), 176 (→ 1415)
92-47020	VOLVO	58 (→ 1352), 59 (→ 1353), ... , 149 (→ 1400), 176 (→ 1415)
92-47021	VOLVO	77 (→ 1358), 80 (→ 1360), 81 (→ 1360), 82 (→ 1360)
92-47022	VOLVO	77 (→ 1358), 80 (→ 1360), 81 (→ 1360), 82 (→ 1360)



Item No.	Type	Pos (→  )
		
92-47023		VOLVO 94 (→ 1366), 95 (→ 1367), 101 (→ 1370)
92-47024		VOLVO 94 (→ 1366), 95 (→ 1367), 101 (→ 1370)
92-47026		VOLVO 147 (→ 1399)
92-47027		VOLVO 147 (→ 1399)
92-47028		RENAULT 126 (→ 1019), 127 (→ 1019)
		VOLVO 150 (→ 1401), 151 (→ 1402), ... , 167 (→ 1411), 168 (→ 1412)
92-47029		RENAULT 126 (→ 1019), 127 (→ 1019)
		VOLVO 150 (→ 1401), 151 (→ 1402), ... , 167 (→ 1411), 168 (→ 1412)
92-47030		RENAULT 122 (→ 1017), 123 (→ 1018)
		VOLVO 55 (→ 1351), 113 (→ 1378), ... , 119 (→ 1382), 120 (→ 1383)
92-47031		RENAULT 122 (→ 1017), 123 (→ 1018)
		VOLVO 55 (→ 1351), 113 (→ 1378), ... , 119 (→ 1382), 120 (→ 1383)
92-47032		VOLVO 58 (→ 1352), 59 (→ 1353), ... , 149 (→ 1400), 176 (→ 1415)
92-47033		VOLVO 58 (→ 1352), 59 (→ 1353), ... , 149 (→ 1400), 176 (→ 1415)
92-47034		RENAULT 126 (→ 1019), 127 (→ 1019)
		VOLVO 150 (→ 1401), 151 (→ 1402), ... , 155 (→ 1405), 157 (→ 1406)
92-47035		RENAULT 126 (→ 1019), 127 (→ 1019)
		VOLVO 150 (→ 1401), 151 (→ 1402), ... , 155 (→ 1405), 157 (→ 1406)
92-47036		VOLVO 178 (→ 1417), 179 (→ 1417), ... , 181 (→ 1417), 182 (→ 1418)
92-47037		VOLVO 178 (→ 1417), 179 (→ 1417), ... , 181 (→ 1417), 182 (→ 1418)
92-47038		VOLVO 178 (→ 1417)
92-47039		VOLVO 178 (→ 1417)
92-47040		VOLVO 174 (→ 1415), 175 (→ 1415), 176 (→ 1415)
92-47041		VOLVO 174 (→ 1415), 175 (→ 1415), 176 (→ 1415)
92-59000		RENAULT 122 (→ 1017), 123 (→ 1018)
92-59001		RENAULT 122 (→ 1017), 123 (→ 1018)
		
20100335200		MERCEDES-BENZ 129 (→ 546), 130 (→ 547), ... , 160 (→ 568), 161 (→ 569)
20100335201		MERCEDES-BENZ 130 (→ 547), 134 (→ 550), ... , 178 (→ 580), 180 (→ 581)
20100335202		MERCEDES-BENZ 141 (→ 555), 143 (→ 556), ... , 158 (→ 566), 162 (→ 570)
20100335500		MERCEDES-BENZ 359 (→ 704), 365 (→ 708), ... , 473 (→ 823), 474 (→ 824)
20100335501		MERCEDES-BENZ 360 (→ 705), 366 (→ 708), 377 (→ 720)
20100336400		MERCEDES-BENZ 188 (→ 585), 201 (→ 594), ... , 222 (→ 608), 223 (→ 608)
20100336401		MERCEDES-BENZ 167 (→ 573), 204 (→ 595), ... , 216 (→ 604), 217 (→ 604)
20100336600		MERCEDES-BENZ 184 (→ 582), 185 (→ 583), 206 (→ 597), 208 (→ 598)
20100336601		MERCEDES-BENZ 144 (→ 557), 145 (→ 558), ... , 233 (→ 613), 235 (→ 614)
20100340101		MERCEDES-BENZ 336 (→ 686), 340 (→ 690), ... , 428 (→ 778), 479 (→ 831)
20100340200		MERCEDES-BENZ 315 (→ 663), 326 (→ 672), ... , 331 (→ 681), 345 (→ 694)
20100340201		MERCEDES-BENZ 337 (→ 688), 338 (→ 688), ... , 424 (→ 773), 432 (→ 782)
20100342200		MERCEDES-BENZ 370 (→ 712), 375 (→ 719), ... , 506 (→ 856), 541 (→ 902)
20100342201		MERCEDES-BENZ 378 (→ 721), 381 (→ 726), ... , 434 (→ 785), 476 (→ 827)
20100344201		MERCEDES-BENZ 436 (→ 787), 439 (→ 790), 444 (→ 796), 480 (→ 832)
20100344701		MERCEDES-BENZ 400 (→ 749), 429 (→ 780), ... , 459 (→ 811), 464 (→ 816)
20100345700		MERCEDES-BENZ 437 (→ 788), 440 (→ 792), ... , 462 (→ 815), 492 (→ 841)
20100345701		MERCEDES-BENZ 440 (→ 792), 441 (→ 793), 460 (→ 813)
20100345704		MERCEDES-BENZ 441 (→ 793), 453 (→ 806), ... , 469 (→ 820), 489 (→ 839)
20100346000		MERCEDES-BENZ 446 (→ 798), 451 (→ 803), ... , 493 (→ 842), 496 (→ 844)
20100346005		MERCEDES-BENZ 448 (→ 800), 449 (→ 801), ... , 495 (→ 843), 497 (→ 845)
20100347000		MERCEDES-BENZ 341 (→ 691), 350 (→ 700), 351 (→ 701), 352 (→ 701)
20100347001		MERCEDES-BENZ 341 (→ 691), 350 (→ 700), 351 (→ 701), 352 (→ 701)
20100347100		MERCEDES-BENZ 556 (→ 915), 557 (→ 915), ... , 564 (→ 917), 565 (→ 917)
20100347101		MERCEDES-BENZ 556 (→ 915), 557 (→ 915), ... , 564 (→ 917), 565 (→ 917)
20100347102		MERCEDES-BENZ 556 (→ 915), 558 (→ 916), ... , 563 (→ 917), 565 (→ 917)
20100347103		MERCEDES-BENZ 556 (→ 915), 558 (→ 916), ... , 563 (→ 917), 565 (→ 917)
20100347104		MERCEDES-BENZ 556 (→ 915), 558 (→ 916)
20100350100		MERCEDES-BENZ 523 (→ 881)
20100350101		MERCEDES-BENZ 512 (→ 864), 513 (→ 865), ... , 546 (→ 907), 548 (→ 909)
20100350200		MERCEDES-BENZ 520 (→ 877), 524 (→ 883), 525 (→ 885), 527 (→ 889)
20100350201		MERCEDES-BENZ 510 (→ 861), 511 (→ 863), ... , 550 (→ 911), 553 (→ 913)
20100354100		MERCEDES-BENZ 516 (→ 870), 518 (→ 873), ... , 537 (→ 899), 547 (→ 908)
20100354200		MERCEDES-BENZ 528 (→ 890), 539 (→ 900), ... , 554 (→ 913), 555 (→ 914)

Item No.	Type	Pos ( →  )
20100361100	MERCEDES-BENZ	68 (→ 521), 69 (→ 521), 73 (→ 523), 74 (→ 524)
20100390400	MERCEDES-BENZ	240 (→ 617), 242 (→ 619), ... , 294 (→ 652), 298 (→ 654)
20100390600	MERCEDES-BENZ	241 (→ 618), 246 (→ 622), ... , 304 (→ 657), 311 (→ 662)
20100390601	MERCEDES-BENZ	238 (→ 616), 245 (→ 621), ... , 308 (→ 660), 311 (→ 662)
20100390605	MERCEDES-BENZ	238 (→ 616), 239 (→ 617), ... , 305 (→ 658), 308 (→ 660)
20100393400	MERCEDES-BENZ	317 (→ 665), 320 (→ 665)
20100393600	MERCEDES-BENZ	316 (→ 664), 319 (→ 665)
20100407100	VOLVO	88 (→ 1363)
20100409000	VOLVO	94 (→ 1366), 95 (→ 1367), ... , 116 (→ 1381), 119 (→ 1383)
20100409001	VOLVO	94 (→ 1366)
20100410000	VOLVO	108 (→ 1375)
20100410200	VOLVO	106 (→ 1374), 111 (→ 1377)
20100411000	VOLVO	113 (→ 1378), 114 (→ 1379), 115 (→ 1380), 117 (→ 1381)
20100411001	RENAULT	122 (→ 1017), 123 (→ 1018)
	VOLVO	113 (→ 1378), 114 (→ 1379), 115 (→ 1380), 117 (→ 1381)
20100411002	RENAULT	123 (→ 1018)
	VOLVO	113 (→ 1378)
20100411003	VOLVO	115 (→ 1380)
20100412004	VOLVO	136 (→ 1391), 141 (→ 1395)
20100412005	VOLVO	137 (→ 1392), 138 (→ 1393)
20100412006	VOLVO	138 (→ 1393), 140 (→ 1395), 143 (→ 1397)
20100412008	VOLVO	136 (→ 1391), 141 (→ 1395)
20100412009	VOLVO	149 (→ 1400)
20100412200	VOLVO	121 (→ 1384), 122 (→ 1384), ... , 131 (→ 1388), 135 (→ 1390)
20100413000	VOLVO	152 (→ 1403), 153 (→ 1404)
20100413001	RENAULT	126 (→ 1019), 127 (→ 1019)
	VOLVO	157 (→ 1406)
20100413002	VOLVO	150 (→ 1401), 157 (→ 1406)
20100413003	VOLVO	164 (→ 1410)
20100413004	VOLVO	164 (→ 1410)
20100413005	RENAULT	127 (→ 1019)
	VOLVO	150 (→ 1401), 151 (→ 1402), 163 (→ 1410)
20100413006	VOLVO	150 (→ 1401), 151 (→ 1402), 157 (→ 1406), 163 (→ 1410)
20100413007	VOLVO	153 (→ 1404)
20100413008	VOLVO	156 (→ 1405)
20100413009	VOLVO	150 (→ 1401), 151 (→ 1402), 163 (→ 1410)
20100413010	VOLVO	162 (→ 1409)
20100413100	VOLVO	158 (→ 1407), 160 (→ 1408), ... , 169 (→ 1412), 170 (→ 1413)
20100416003	VOLVO	182 (→ 1418)
20101408000	FIAT	143 (→ 258)
20101419000	FORD	161 (→ 346)
50 006 106	VOLKSWAGEN	262 (→ 1227)
50 006 107	VOLKSWAGEN	261 (→ 1227)
50 006 109	VOLKSWAGEN	261 (→ 1227)
50 006 110	VOLKSWAGEN	266 (→ 1228)
50 006 155	SKODA	19 (→ 1040), 20 (→ 1040), 22 (→ 1041)
	VOLKSWAGEN	56 (→ 1140), 57 (→ 1141), ... , 75 (→ 1150), 85 (→ 1155)
50 006 156	SKODA	19 (→ 1040)
	VOLKSWAGEN	56 (→ 1140)
50 006 188	RENAULT	91 (→ 1008), 92 (→ 1008), 93 (→ 1008)
50 006 189	FIAT	63 (→ 232)
50 006 198	RENAULT	41 (→ 991), 45 (→ 993), 47 (→ 994), 54 (→ 997)
50 006 202	SKODA	41 (→ 1051), 42 (→ 1052)
	VOLKSWAGEN	150 (→ 1179), 151 (→ 1180), 187 (→ 1197)
50 006 203	VOLKSWAGEN	134 (→ 1171), 137 (→ 1174), 168 (→ 1187)
50 006 204	SKODA	40 (→ 1051)
	VOLKSWAGEN	144 (→ 1177), 145 (→ 1177), 148 (→ 1178)
50 006 205	FORD	44 (→ 306), 45 (→ 306)
	VOLKSWAGEN	138 (→ 1174), 140 (→ 1175), 149 (→ 1179), 152 (→ 1180)
50 006 210	SKODA	43 (→ 1052), 44 (→ 1052)
	VOLKSWAGEN	147 (→ 1178), 155 (→ 1181)
50 006 212	MERCEDES-BENZ	78 (→ 526), 118 (→ 542)

Item No.	Type	Pos (→  )
50 006 214	VOLKSWAGEN	104 (→ 1161), 105 (→ 1162), ... , 113 (→ 1165), 114 (→ 1165)
50 006 215	VOLKSWAGEN	136 (→ 1173)
50 006 216	VOLKSWAGEN	136 (→ 1173), 154 (→ 1181)
50 006 218	VOLKSWAGEN	100 (→ 1160), 101 (→ 1160), ... , 112 (→ 1165), 115 (→ 1166)
50 006 220	FIAT	58 (→ 231), 59 (→ 231), ... , 67 (→ 233), 68 (→ 234)
	ROVER	11 (→ 1024)
50 006 222	MERCEDES-BENZ	79 (→ 527), 119 (→ 542)
50 006 223	MERCEDES-BENZ	28 (→ 505), 76 (→ 525)
50 006 226	MERCEDES-BENZ	77 (→ 525), 90 (→ 533), 91 (→ 533), 104 (→ 538)
50 006 234	BMW	78 (→ 190), 86 (→ 192)
50 006 235	BMW	35 (→ 174), 36 (→ 175)
50 006 239	BMW	50 (→ 180)
50 006 241	BMW	12 (→ 168)
50 006 257	FORD	100 (→ 323), 113 (→ 332), ... , 133 (→ 340), 135 (→ 341)
50 006 259	FORD	17 (→ 298), 33 (→ 302), ... , 54 (→ 309), 62 (→ 311)
50 006 260	FORD	38 (→ 304), 118 (→ 333), ... , 136 (→ 342), 137 (→ 342)
50 006 280	MERCEDES-BENZ	109 (→ 540), 123 (→ 543)
50 006 281	MERCEDES-BENZ	109 (→ 540), 123 (→ 543)
50 006 282	MERCEDES-BENZ	60 (→ 517), 83 (→ 529), 87 (→ 531)
50 006 283	VOLKSWAGEN	259 (→ 1226), 260 (→ 1226), 281 (→ 1237)
50 006 284	MERCEDES-BENZ	61 (→ 517), 82 (→ 528), 88 (→ 532)
50 006 287	MERCEDES-BENZ	62 (→ 518), 84 (→ 529)
50 006 300	SKODA	38 (→ 1050)
	VOLKSWAGEN	122 (→ 1168), 123 (→ 1168)
50 006 301	SKODA	38 (→ 1050)
	VOLKSWAGEN	122 (→ 1168), 123 (→ 1168)
50 006 302	SKODA	38 (→ 1050)
	VOLKSWAGEN	122 (→ 1168), 123 (→ 1168)
50 006 303	SKODA	38 (→ 1050)
	VOLKSWAGEN	122 (→ 1168), 123 (→ 1168)
50 006 304	FORD	46 (→ 307)
	SKODA	45 (→ 1053), 46 (→ 1054), ... , 49 (→ 1055), 51 (→ 1057)
	VOLKSWAGEN	156 (→ 1182), 157 (→ 1183), ... , 174 (→ 1191), 178 (→ 1193)
50 006 306	VOLKSWAGEN	298 (→ 1243)
50 006 307	SKODA	66 (→ 1063)
	VOLKSWAGEN	239 (→ 1217), 251 (→ 1222)
50 006 308	SKODA	66 (→ 1063), 67 (→ 1063), 68 (→ 1064)
	VOLKSWAGEN	239 (→ 1217), 243 (→ 1219), 251 (→ 1222)
50 006 309	SKODA	69 (→ 1064)
	VOLKSWAGEN	252 (→ 1222), 253 (→ 1223)
50 006 314	NISSAN	6 (→ 931)
	RENAULT	18 (→ 982), 24 (→ 985), 26 (→ 986)
50 006 315	NISSAN	13 (→ 933)
	RENAULT	33 (→ 988), 38 (→ 991)
50 006 316	NISSAN	13 (→ 933)
	RENAULT	33 (→ 988), 38 (→ 991)
50 006 327	BMW	32 (→ 173), 36 (→ 175), ... , 56 (→ 182), 58 (→ 183)
50 006 330	NISSAN	31 (→ 937)
50 006 332	RENAULT	46 (→ 993), 48 (→ 994), 49 (→ 995)
50 006 337	MERCEDES-BENZ	85 (→ 530)
50 006 342	SKODA	53 (→ 1058), 76 (→ 1068), ... , 78 (→ 1069), 80 (→ 1070)
	VOLKSWAGEN	162 (→ 1185), 165 (→ 1186), ... , 273 (→ 1233), 280 (→ 1236)
50 006 343	VOLKSWAGEN	269 (→ 1230)
50 006 344	SKODA	39 (→ 1050)
	VOLKSWAGEN	124 (→ 1169)
50 006 345	SKODA	39 (→ 1050)
	VOLKSWAGEN	124 (→ 1169)
50 006 346	SKODA	39 (→ 1050)
	VOLKSWAGEN	124 (→ 1169)
50 006 347	SKODA	39 (→ 1050)
	VOLKSWAGEN	124 (→ 1169)
50 006 375	MERCEDES-BENZ	68 (→ 521), 69 (→ 521)

KS/TRW/BF No. → Application

Item No.	Type	Pos ( →  )
50 006 376	MERCEDES-BENZ	92 (→ 533), 94 (→ 534), 99 (→ 536)
50 006 380	VOLKSWAGEN	49 (→ 1138)
50 006 381	VOLKSWAGEN	1 (→ 1125)
50 006 382	SKODA	18 (→ 1039)
	VOLKSWAGEN	53 (→ 1139)
50 006 388	SKODA	48 (→ 1055), 54 (→ 1058)
	VOLKSWAGEN	158 (→ 1183), 166 (→ 1187)
50 006 389	FIAT	78 (→ 236), 79 (→ 237)
	LANCIA	37 (→ 360)
50 006 397	VOLKSWAGEN	190 (→ 1197), 191 (→ 1198), ... , 230 (→ 1213), 258 (→ 1225)
50 006 398	SKODA	65 (→ 1062), 84 (→ 1071)
	VOLKSWAGEN	234 (→ 1215), 235 (→ 1215), ... , 303 (→ 1246), 304 (→ 1246)
50 006 399	VOLKSWAGEN	262 (→ 1227)
50 007 002	VOLKSWAGEN	350 (→ 1265)
50 007 003	VOLKSWAGEN	350 (→ 1265)
50 007 004	VOLKSWAGEN	348 (→ 1264), 349 (→ 1264), ... , 353 (→ 1266), 356 (→ 1267)
50 007 005	VOLKSWAGEN	348 (→ 1264), 349 (→ 1264), ... , 353 (→ 1266), 356 (→ 1267)
50 007 006	VOLKSWAGEN	348 (→ 1264), 349 (→ 1264)
50 007 008	VOLKSWAGEN	348 (→ 1264), 349 (→ 1264), 351 (→ 1265), 352 (→ 1266)
50 007 010	FIAT	76 (→ 236), 77 (→ 236), 81 (→ 238)
	LANCIA	38 (→ 361), 42 (→ 362)
50 007 012	FIAT	76 (→ 236), 77 (→ 236), 81 (→ 238)
	LANCIA	38 (→ 361), 42 (→ 362)
50 007 015	VOLKSWAGEN	351 (→ 1265), 352 (→ 1266), 353 (→ 1266), 356 (→ 1267)
50 007 017	NISSAN	6 (→ 931)
	RENAULT	18 (→ 982), 20 (→ 983), 22 (→ 984), 26 (→ 986)
50 007 018	SKODA	32 (→ 1047), 33 (→ 1048), 34 (→ 1048)
	VOLKSWAGEN	72 (→ 1148), 73 (→ 1149), ... , 87 (→ 1156), 96 (→ 1159)
50 007 019	SKODA	28 (→ 1045), 34 (→ 1048)
	VOLKSWAGEN	73 (→ 1149), 77 (→ 1151), ... , 86 (→ 1156), 96 (→ 1159)
50 007 020	SKODA	57 (→ 1059), 75 (→ 1067)
	VOLKSWAGEN	181 (→ 1194), 272 (→ 1232), ... , 287 (→ 1239), 288 (→ 1240)
50 007 022	SKODA	57 (→ 1059), 75 (→ 1067)
	VOLKSWAGEN	181 (→ 1194), 272 (→ 1232), 287 (→ 1239), 288 (→ 1240)
50 007 024	FIAT	7 (→ 219), 9 (→ 220)
	FORD	3 (→ 292)
	LANCIA	3 (→ 352), 4 (→ 352)
50 007 025	SKODA	30 (→ 1046)
	VOLKSWAGEN	84 (→ 1155), 88 (→ 1157)
50 007 026	SKODA	30 (→ 1046)
	VOLKSWAGEN	84 (→ 1155), 88 (→ 1157)
50 007 028	FORD	126 (→ 337), 127 (→ 338)
50 007 029	FORD	73 (→ 314)
50 007 034	SKODA	26 (→ 1044)
	VOLKSWAGEN	69 (→ 1147)
50 007 035	SKODA	26 (→ 1044)
	VOLKSWAGEN	69 (→ 1147)
50 007 038	FIAT	51 (→ 228), 53 (→ 229), 56 (→ 230)
	LANCIA	25 (→ 358)
50 007 039	VOLKSWAGEN	70 (→ 1147)
50 007 040	VOLKSWAGEN	70 (→ 1147)
50 007 047	FIAT	120 (→ 250), 122 (→ 251), 123 (→ 251)
50 007 048	FIAT	120 (→ 250), 121 (→ 251), 122 (→ 251), 123 (→ 251)
50 007 050	FORD	107 (→ 327)
50 007 051	FORD	107 (→ 327)
50 007 054	FIAT	110 (→ 246), 112 (→ 247), 113 (→ 247)
	RENAULT	102 (→ 1012), 103 (→ 1012)
50 007 056	SKODA	32 (→ 1047)
	VOLKSWAGEN	78 (→ 1152), 82 (→ 1154)
50 007 076	MERCEDES-BENZ	6 (→ 498), 7 (→ 498)
	NISSAN	6 (→ 931), 8 (→ 932), 9 (→ 933)
	RENAULT	24 (→ 985), 26 (→ 986), 27 (→ 987)

Item No.	Type	Pos (→  )
50 007 081		FORD 13 (→ 296)
50 007 083		FORD 13 (→ 296)
50 007 085		FORD 90 (→ 319), 91 (→ 320), ... , 105 (→ 325), 106 (→ 326)
50 007 088		FIAT 80 (→ 237)
		LANCIA 39 (→ 361)
50 007 089		FIAT 80 (→ 237)
		LANCIA 39 (→ 361)
50 007 093		FORD 22 (→ 299)
		VOLVO 3 (→ 1337)
50 007 094		FORD 22 (→ 299)
		VOLVO 3 (→ 1337)
50 007 095		FORD 90 (→ 319), 91 (→ 320), ... , 105 (→ 325), 106 (→ 326)
50 007 096		FORD 87 (→ 318)
50 007 099		FORD 87 (→ 318)
50 007 101		FORD 121 (→ 334), 123 (→ 335), 124 (→ 335)
50 007 102		FORD 121 (→ 334), 123 (→ 335), 124 (→ 335)
50 007 104		FIAT 54 (→ 229), 55 (→ 230)
50 007 105		FIAT 54 (→ 229), 55 (→ 230)
50 007 118		NISSAN 38 (→ 939), 41 (→ 940)
		RENAULT 94 (→ 1009), 96 (→ 1010)
50 007 123		NISSAN 38 (→ 939), 41 (→ 940)
		RENAULT 94 (→ 1009), 96 (→ 1010)
50 007 124		NISSAN 38 (→ 939), 41 (→ 940)
		RENAULT 94 (→ 1009), 96 (→ 1010)
50 007 126		NISSAN 38 (→ 939), 41 (→ 940)
		RENAULT 94 (→ 1009), 96 (→ 1010)
50 007 567		FIAT 61 (→ 232)
50 007 572		FIAT 7 (→ 219), 9 (→ 220)
		FORD 3 (→ 292)
		LANCIA 3 (→ 352), 4 (→ 352)
50 007 573		FORD 22 (→ 299)
		VOLVO 3 (→ 1337)
50 007 574		FORD 22 (→ 299)
		VOLVO 3 (→ 1337)
50 007 575		SKODA 74 (→ 1066), 79 (→ 1069)
		VOLKSWAGEN 267 (→ 1229), 276 (→ 1234), 277 (→ 1235), 366 (→ 1271)
50 007 576		SKODA 74 (→ 1066)
		VOLKSWAGEN 267 (→ 1229), 275 (→ 1234), 366 (→ 1271)
50 007 577		VOLKSWAGEN 265 (→ 1228), 268 (→ 1229)
50 007 578		SKODA 79 (→ 1069)
		VOLKSWAGEN 276 (→ 1234), 277 (→ 1235)
50 007 579		VOLKSWAGEN 237 (→ 1216)
50 007 580		VOLKSWAGEN 237 (→ 1216), 240 (→ 1217)
50 007 581		SKODA 68 (→ 1064), 71 (→ 1065)
		VOLKSWAGEN 243 (→ 1219), 248 (→ 1220)
50 007 582		VOLKSWAGEN 270 (→ 1230)
50 007 586		SKODA 89 (→ 1074)
		VOLKSWAGEN 309 (→ 1249)
50 007 587		SKODA 89 (→ 1074)
		VOLKSWAGEN 309 (→ 1249)
50 007 588		SKODA 88 (→ 1073)
		VOLKSWAGEN 308 (→ 1248)
50 007 589		SKODA 88 (→ 1073)
		VOLKSWAGEN 308 (→ 1248)
50 007 590		MERCEDES-BENZ 11 (→ 499)
50 007 591		MERCEDES-BENZ 10 (→ 499)
50 007 592		MERCEDES-BENZ 17 (→ 501), 21 (→ 502), ... , 23 (→ 503), 25 (→ 504)
50 007 593		MERCEDES-BENZ 17 (→ 501), 21 (→ 502), ... , 23 (→ 503), 25 (→ 504)
50 007 594		VOLKSWAGEN 196 (→ 1200), 200 (→ 1202), ... , 229 (→ 1213), 231 (→ 1213)
50 007 633		SKODA 55 (→ 1059)
		VOLKSWAGEN 176 (→ 1192)
50 007 634		SKODA 91 (→ 1075), 92 (→ 1075), 93 (→ 1076)

KS/TRW/BF No. → Application





Item No.	Type	Pos (→  )
		<b>Pos (→  )</b>
	VOLKSWAGEN	315 (→ 1251), 316 (→ 1252), 318 (→ 1253), 319 (→ 1253)
50 007 635	SKODA	91 (→ 1075), 92 (→ 1075), 93 (→ 1076)
	VOLKSWAGEN	315 (→ 1251), 316 (→ 1252), 318 (→ 1253), 319 (→ 1253)
50 007 636	SKODA	21 (→ 1041)
	VOLKSWAGEN	58 (→ 1141), 60 (→ 1142)
50 007 637	SKODA	21 (→ 1041)
	VOLKSWAGEN	58 (→ 1141), 60 (→ 1142)
50 007 639	BMW	43 (→ 178), 44 (→ 178)
50 007 654	SKODA	25 (→ 1043), 35 (→ 1048), 36 (→ 1049)
	VOLKSWAGEN	64 (→ 1144), 91 (→ 1158)
50 007 655	SKODA	25 (→ 1043), 35 (→ 1048), 36 (→ 1049)
	VOLKSWAGEN	64 (→ 1144), 91 (→ 1158)
50 007 656	SKODA	28 (→ 1045)
	VOLKSWAGEN	74 (→ 1150)
50 007 669	SKODA	90 (→ 1074), 91 (→ 1075), 92 (→ 1075), 93 (→ 1076)
	VOLKSWAGEN	322 (→ 1254)
50 007 670	SKODA	94 (→ 1077), 95 (→ 1077), ... , 99 (→ 1079), 100 (→ 1079)
	VOLKSWAGEN	325 (→ 1256), 327 (→ 1256), ... , 339 (→ 1261), 342 (→ 1262)
50 007 671	MERCEDES-BENZ	36 (→ 507), 39 (→ 509), 41 (→ 510), 45 (→ 511)
50 007 672	MERCEDES-BENZ	36 (→ 507), 39 (→ 509), 41 (→ 510), 45 (→ 511)
50 007 673	SKODA	90 (→ 1074)
	VOLKSWAGEN	310 (→ 1249), 313 (→ 1251), ... , 321 (→ 1254), 322 (→ 1254)
50 007 674	FORD	23 (→ 300)
50 007 675	SKODA	58 (→ 1060)
	VOLKSWAGEN	183 (→ 1195)
50 007 676	SKODA	58 (→ 1060)
	VOLKSWAGEN	183 (→ 1195)
50 007 677	SKODA	1 (→ 1035)
	VOLKSWAGEN	8 (→ 1126), 9 (→ 1127)
50 007 678	SKODA	22 (→ 1041), 29 (→ 1045)
	VOLKSWAGEN	75 (→ 1150), 76 (→ 1151), 85 (→ 1155)
50 007 679	VOLKSWAGEN	75 (→ 1150), 76 (→ 1151)
50 007 680	VOLKSWAGEN	71 (→ 1148)
50 007 681	VOLKSWAGEN	71 (→ 1148)
50 007 682	BMW	60 (→ 184)
50 007 683	BMW	60 (→ 184)
50 007 684	BMW	43 (→ 178)
50 007 685	FIAT	20 (→ 222)
50 007 686	FORD	111 (→ 330), 112 (→ 331)
50 007 687	FORD	111 (→ 330), 112 (→ 331)
50 007 693	MERCEDES-BENZ	34 (→ 506), 35 (→ 507), ... , 43 (→ 511), 46 (→ 512)
50 007 694	MERCEDES-BENZ	34 (→ 506), 35 (→ 507), ... , 42 (→ 510), 46 (→ 512)
50 007 695	MERCEDES-BENZ	34 (→ 506), 35 (→ 507), ... , 40 (→ 510), 42 (→ 510)
50 007 696	MERCEDES-BENZ	38 (→ 509)
50 007 697	MERCEDES-BENZ	38 (→ 509)
50 007 698	MERCEDES-BENZ	96 (→ 535), 101 (→ 537)
50 007 699	MERCEDES-BENZ	96 (→ 535), 97 (→ 535), 101 (→ 537)
50 007 703	NISSAN	39 (→ 939)
50 007 704	NISSAN	39 (→ 939)
50 007 709	RENAULT	73 (→ 1002), 74 (→ 1003), ... , 86 (→ 1007), 87 (→ 1007)
50 007 710	RENAULT	73 (→ 1002), 74 (→ 1003), ... , 86 (→ 1007), 87 (→ 1007)
50 007 712	SKODA	90 (→ 1074)
	VOLKSWAGEN	313 (→ 1251)
50 007 774	RENAULT	36 (→ 990)
50 007 776	RENAULT	36 (→ 990)
50 007 777	FIAT	54 (→ 229), 55 (→ 230)
50 007 778	FORD	9 (→ 294)
50 007 779	FORD	94 (→ 321)
50 007 780	FORD	80 (→ 316), 81 (→ 316)
50 007 785	BMW	61 (→ 185)
50 007 786	BMW	61 (→ 185)
50 007 799	FIAT	10 (→ 220), 11 (→ 220), 12 (→ 220)



Item No.	Type	Pos (→  )
		FORD 1 (→ 292), 2 (→ 292)
		LANCIA 5 (→ 353)
50 007 800		FIAT 10 (→ 220), 11 (→ 220), 12 (→ 220)
		FORD 1 (→ 292), 2 (→ 292)
		LANCIA 5 (→ 353)
50 007 802		NISSAN 39 (→ 939)
50 007 803		NISSAN 39 (→ 939)
50 007 854		NISSAN 25 (→ 936)
		RENAULT 77 (→ 1004), 82 (→ 1005)
		VOLKSWAGEN 404 (→ 1281)
20010208260		VOLVO 89 (→ 1364)
20010510140		RENAULT 113 (→ 1015), 117 (→ 1016), 119 (→ 1016)
20010522700		FORD 145 (→ 344)
20100335260		MERCEDES-BENZ 126 (→ 544), 128 (→ 545), ... , 235 (→ 614), 236 (→ 615)
20100335560		MERCEDES-BENZ 359 (→ 704), 360 (→ 705), ... , 367 (→ 709), 474 (→ 824)
20100340060		MERCEDES-BENZ 315 (→ 664), 325 (→ 671), ... , 506 (→ 856), 509 (→ 860)
20100344000		MERCEDES-BENZ 315 (→ 664), 324 (→ 669), ... , 507 (→ 857), 509 (→ 860)
20100344001		MERCEDES-BENZ 315 (→ 664), 324 (→ 669), ... , 507 (→ 857), 509 (→ 860)
20100350060		MERCEDES-BENZ 437 (→ 788), 440 (→ 792), ... , 545 (→ 907), 554 (→ 914)
20100350062		MERCEDES-BENZ 437 (→ 788), 446 (→ 798), ... , 554 (→ 914), 555 (→ 914)
20100390660		MERCEDES-BENZ 238 (→ 616), 240 (→ 617), ... , 313 (→ 662), 314 (→ 663)
20100412001		VOLVO 103 (→ 1371), 104 (→ 1372), ... , 131 (→ 1388), 135 (→ 1391)
20100412003		VOLVO 103 (→ 1371), 104 (→ 1372), ... , 131 (→ 1388), 135 (→ 1391)
20100416001		VOLVO 173 (→ 1414)
20100470000		VOLVO 60 (→ 1353), 61 (→ 1353), ... , 73 (→ 1357), 78 (→ 1359)
20100522510		RENAULT 109 (→ 1014)
20100522660		RENAULT 117 (→ 1016), 118 (→ 1016), 119 (→ 1016)
20100541360		FORD 159 (→ 346), 160 (→ 346)
20101220000		FORD 157 (→ 345), 158 (→ 346)
		VOLKSWAGEN 405 (→ 1282), 406 (→ 1282)
201012B6060		FORD 148 (→ 344), 153 (→ 345)
		VOLKSWAGEN 400 (→ 1280)
20101406001		FIAT 132 (→ 253)
50 006 135		BMW 5 (→ 165)
50 006 138		VOLKSWAGEN 55 (→ 1140)
50 006 145		FIAT 77 (→ 236)
		FORD 87 (→ 318), 88 (→ 318), ... , 92 (→ 320), 94 (→ 321)
		LANCIA 40 (→ 361), 42 (→ 362)
50 006 169		FIAT 77 (→ 236)
		LANCIA 40 (→ 361), 42 (→ 362)
50 006 180		FIAT 98 (→ 242), 101 (→ 243), ... , 115 (→ 249), 118 (→ 250)
		LANCIA 52 (→ 364), 53 (→ 365)
		RENAULT 100 (→ 1011), 103 (→ 1012), 105 (→ 1013), 106 (→ 1013)
50 006 409		BMW 10 (→ 167), 11 (→ 167), ... , 53 (→ 181), 94 (→ 194)
50 006 411		SKODA 38 (→ 1050)
		VOLKSWAGEN 122 (→ 1168), 123 (→ 1168)
50 006 414		BMW 16 (→ 169), 59 (→ 184), ... , 67 (→ 187), 68 (→ 187)
		ROVER 13 (→ 1024)
		VOLVO 24 (→ 1343), 26 (→ 1343), 45 (→ 1348)
50 006 415		SKODA 1 (→ 1035), 19 (→ 1040), ... , 34 (→ 1048), 36 (→ 1049)
		VOLKSWAGEN 2 (→ 1125), 8 (→ 1126), ... , 87 (→ 1156), 251 (→ 1222)
50 006 417		FORD 45 (→ 306)
		SKODA 18 (→ 1039), 40 (→ 1051), ... , 84 (→ 1072), 85 (→ 1072)
		VOLKSWAGEN 1 (→ 1125), 49 (→ 1138), ... , 304 (→ 1247), 305 (→ 1247)
50 006 418		FORD 46 (→ 307), 47 (→ 307)
		SKODA 45 (→ 1053), 46 (→ 1054), ... , 77 (→ 1068), 80 (→ 1070)
		VOLKSWAGEN 116 (→ 1166), 156 (→ 1182), ... , 286 (→ 1239), 293 (→ 1242)
50 006 419		FORD 13 (→ 296)
		SKODA 69 (→ 1064), 70 (→ 1065), ... , 92 (→ 1075), 95 (→ 1077)
		VOLKSWAGEN 252 (→ 1222), 253 (→ 1223), ... , 338 (→ 1261), 370 (→ 1272)

Item No.	Type	Pos ( →  )
50 006 420	SKODA	39 (→ 1050)
	VOLKSWAGEN	124 (→ 1169), 348 (→ 1264), 349 (→ 1264)
50 006 421	MERCEDES-BENZ	52 (→ 513), 77 (→ 525), ... , 125 (→ 544), 250 (→ 624)
	VOLKSWAGEN	390 (→ 1278)
50 006 422	FIAT	18 (→ 222), 42 (→ 226), ... , 94 (→ 241), 95 (→ 241)
	LANCIA	9 (→ 353), 16 (→ 355), ... , 46 (→ 363), 47 (→ 363)
50 006 424	MERCEDES-BENZ	56 (→ 515), 68 (→ 521), ... , 74 (→ 524), 75 (→ 524)
50 006 425	SKODA	64 (→ 1062), 66 (→ 1063), ... , 71 (→ 1065), 87 (→ 1073)
	VOLKSWAGEN	237 (→ 1216), 239 (→ 1217), ... , 251 (→ 1222), 302 (→ 1246)
50 006 426	SKODA	64 (→ 1062), 66 (→ 1063), ... , 71 (→ 1065), 87 (→ 1073)
	VOLKSWAGEN	237 (→ 1216), 239 (→ 1217), ... , 251 (→ 1222), 302 (→ 1246)
50 006 427	RENAULT	41 (→ 992), 42 (→ 992), ... , 60 (→ 999), 64 (→ 999)
50 006 428	FIAT	87 (→ 239)
	FORD	71 (→ 313)
50 006 431	RENAULT	90 (→ 1008), 91 (→ 1008), 92 (→ 1008), 93 (→ 1009)
50 006 432	FIAT	54 (→ 229), 55 (→ 230), ... , 78 (→ 237), 79 (→ 237)
	FORD	12 (→ 296), 13 (→ 296), ... , 24 (→ 300), 25 (→ 300)
	LANCIA	37 (→ 360), 38 (→ 361)
	MERCEDES-BENZ	17 (→ 501), 18 (→ 501), ... , 115 (→ 541), 237 (→ 615)
	NISSAN	24 (→ 936), 25 (→ 936), 26 (→ 936), 32 (→ 938)
	RENAULT	73 (→ 1002), 74 (→ 1003), ... , 86 (→ 1007), 88 (→ 1007)
	VOLVO	4 (→ 1338)
50 006 433	FORD	22 (→ 299)
	VOLVO	3 (→ 1337)
50 006 435	FIAT	77 (→ 236), 78 (→ 237), ... , 121 (→ 251), 122 (→ 251)
	LANCIA	39 (→ 361), 40 (→ 361), 42 (→ 362)
50 006 437	NISSAN	13 (→ 933), 19 (→ 935)
	RENAULT	33 (→ 988), 34 (→ 989), ... , 66 (→ 1000), 69 (→ 1001)
50 006 438	FIAT	7 (→ 219), 8 (→ 219), ... , 57 (→ 231), 69 (→ 234)
	FORD	3 (→ 292)
	LANCIA	3 (→ 352), 4 (→ 353), ... , 24 (→ 357), 30 (→ 359)
50 006 454	MERCEDES-BENZ	28 (→ 505), 76 (→ 525), 79 (→ 527), 119 (→ 543)
50 006 456	MERCEDES-BENZ	60 (→ 517), 61 (→ 517), ... , 87 (→ 531), 88 (→ 532)
50 006 460	FORD	44 (→ 306), 63 (→ 311), 64 (→ 311)
	SKODA	41 (→ 1051)
	VOLKSWAGEN	29 (→ 1132), 37 (→ 1134), ... , 298 (→ 1244), 300 (→ 1245)
50 006 475	BMW	9 (→ 167), 15 (→ 169), ... , 38 (→ 176), 53 (→ 181)
50 006 476	BMW	32 (→ 174), 35 (→ 175), ... , 69 (→ 188), 70 (→ 188)
50 006 477	FORD	19 (→ 298), 27 (→ 301), ... , 53 (→ 309), 54 (→ 309)
50 006 480	FIAT	74 (→ 235)
	LANCIA	35 (→ 360)
50 006 490	SKODA	57 (→ 1060), 58 (→ 1060), ... , 75 (→ 1067), 81 (→ 1070)
	VOLKSWAGEN	181 (→ 1194), 182 (→ 1195), ... , 358 (→ 1268), 360 (→ 1269)
50 006 491	FORD	65 (→ 312)
	VOLKSWAGEN	245 (→ 1219), 246 (→ 1220), ... , 383 (→ 1276), 385 (→ 1276)
50 006 492	BMW	22 (→ 171), 23 (→ 171), ... , 71 (→ 188), 73 (→ 189)
50 006 493	BMW	42 (→ 177), 43 (→ 178), ... , 88 (→ 193), 91 (→ 194)
50 006 494	FIAT	82 (→ 238)
	FORD	90 (→ 319), 91 (→ 320), 95 (→ 322), 98 (→ 323)
50 007 540	NISSAN	6 (→ 932), 17 (→ 934)
	RENAULT	18 (→ 982), 19 (→ 983), ... , 50 (→ 996), 55 (→ 997)
50 007 541	NISSAN	6 (→ 932), 17 (→ 934)
	RENAULT	18 (→ 982), 19 (→ 983), ... , 50 (→ 996), 55 (→ 997)
50 007 542	NISSAN	6 (→ 932), 17 (→ 934)
	RENAULT	18 (→ 982), 19 (→ 983), ... , 50 (→ 996), 55 (→ 997)
50 007 543	NISSAN	6 (→ 932), 17 (→ 934)
	RENAULT	18 (→ 982), 19 (→ 983), ... , 50 (→ 996), 55 (→ 997)
50 007 544	NISSAN	6 (→ 932), 17 (→ 934)
	RENAULT	18 (→ 982), 19 (→ 983), ... , 50 (→ 996), 55 (→ 997)
50 007 545	NISSAN	6 (→ 932), 17 (→ 934)
	RENAULT	18 (→ 982), 19 (→ 983), ... , 50 (→ 996), 55 (→ 997)
50 007 546	NISSAN	6 (→ 932), 17 (→ 934)

Item No.	Type	Pos (→  )
		
50 007 547	RENAULT	18 (→ 982), 19 (→ 983), ... , 50 (→ 996), 55 (→ 997)
	NISSAN	6 (→ 932), 17 (→ 934)
50 007 548	RENAULT	18 (→ 982), 19 (→ 983), ... , 50 (→ 996), 55 (→ 997)
	NISSAN	6 (→ 932), 17 (→ 934)
50 007 549	RENAULT	18 (→ 982), 19 (→ 983), ... , 50 (→ 996), 55 (→ 997)
	NISSAN	6 (→ 932), 17 (→ 934)
50 007 596	RENAULT	18 (→ 982), 19 (→ 983), ... , 50 (→ 996), 55 (→ 997)
	VOLKSWAGEN	138 (→ 1174)
50 007 597	FORD	28 (→ 301), 30 (→ 302), 57 (→ 310)
50 007 599	FORD	86 (→ 317)
50 007 602	NISSAN	28 (→ 937), 30 (→ 937), 31 (→ 937)
50 007 604	RENAULT	59 (→ 998), 62 (→ 999)
50 007 605	RENAULT	72 (→ 1002)
	VOLVO	16 (→ 1340), 19 (→ 1341), ... , 36 (→ 1346), 37 (→ 1346)
50 007 614	BMW	5 (→ 165)
50 007 616	FIAT	4 (→ 218)
50 007 620	FIAT	21 (→ 222), 23 (→ 223)
	LANCIA	11 (→ 354), 12 (→ 354)
50 007 621	VOLKSWAGEN	30 (→ 1133), 46 (→ 1137), ... , 203 (→ 1203), 258 (→ 1225)
50 007 625	VOLKSWAGEN	381 (→ 1275), 382 (→ 1275), ... , 398 (→ 1280), 399 (→ 1280)
50 007 640	MERCEDES-BENZ	36 (→ 508), 38 (→ 509), ... , 41 (→ 510), 45 (→ 512)
50 007 652	FORD	107 (→ 327), 108 (→ 328), ... , 126 (→ 337), 127 (→ 338)
50 007 664	FORD	77 (→ 315)
50 007 665	NISSAN	14 (→ 934), 22 (→ 935), 23 (→ 935)
50 007 666	NISSAN	29 (→ 937)
50 007 667	SKODA	2 (→ 1035), 3 (→ 1036), ... , 11 (→ 1037), 16 (→ 1038)
	VOLKSWAGEN	11 (→ 1128), 13 (→ 1128), ... , 323 (→ 1255), 333 (→ 1258)
50 007 814	MERCEDES-BENZ	1 (→ 497)
	NISSAN	3 (→ 929), 4 (→ 930), 5 (→ 931)
	RENAULT	9 (→ 978), 11 (→ 979), 12 (→ 980)
50 007 815	MERCEDES-BENZ	1 (→ 497)
	NISSAN	3 (→ 929), 4 (→ 930), 5 (→ 931)
	RENAULT	9 (→ 978), 11 (→ 979), 12 (→ 980)
50 007 816	MERCEDES-BENZ	1 (→ 497)
	NISSAN	3 (→ 929), 4 (→ 930), 5 (→ 931)
	RENAULT	9 (→ 978), 11 (→ 979), 12 (→ 980)
50 007 818	MERCEDES-BENZ	1 (→ 497)
	NISSAN	3 (→ 929), 4 (→ 930), 5 (→ 931)
	RENAULT	9 (→ 978), 11 (→ 979), 12 (→ 980)
50 007 819	MERCEDES-BENZ	1 (→ 497)
	NISSAN	3 (→ 929), 4 (→ 930), 5 (→ 931)
	RENAULT	9 (→ 978), 11 (→ 979), 12 (→ 980)
50 007 820	MERCEDES-BENZ	1 (→ 497)
	NISSAN	3 (→ 929), 4 (→ 930), 5 (→ 931)
	RENAULT	9 (→ 978), 11 (→ 979), 12 (→ 980)
50 007 821	MERCEDES-BENZ	1 (→ 497)
	NISSAN	3 (→ 929), 4 (→ 930), 5 (→ 931)
	RENAULT	9 (→ 978), 11 (→ 979), 12 (→ 980)
50 007 822	MERCEDES-BENZ	1 (→ 497)
	NISSAN	3 (→ 929), 4 (→ 930), 5 (→ 931)
	RENAULT	9 (→ 978), 11 (→ 979), 12 (→ 980)
50 007 823	MERCEDES-BENZ	1 (→ 497)
	NISSAN	3 (→ 929), 4 (→ 930), 5 (→ 931)
	RENAULT	9 (→ 978), 11 (→ 979), 12 (→ 980)
50 007 824	MERCEDES-BENZ	1 (→ 497)
	NISSAN	3 (→ 929), 4 (→ 930), 5 (→ 931)
	RENAULT	9 (→ 978), 11 (→ 979), 12 (→ 980)
50 007 825	MERCEDES-BENZ	1 (→ 497)
	NISSAN	3 (→ 929), 4 (→ 930), 5 (→ 931)
	RENAULT	9 (→ 978), 11 (→ 979), 12 (→ 980)
50 007 826	MERCEDES-BENZ	1 (→ 497)
	NISSAN	3 (→ 929), 4 (→ 930), 5 (→ 931)

Item No.	Type	Pos ( →  )
50 007 827	RENAULT	9 (→ 978), 11 (→ 979), 12 (→ 980)
	MERCEDES-BENZ	1 (→ 497)
	NISSAN	3 (→ 929), 4 (→ 930), 5 (→ 931)
50 007 828	RENAULT	9 (→ 978), 11 (→ 979), 12 (→ 980)
	MERCEDES-BENZ	1 (→ 497)
	NISSAN	3 (→ 929), 4 (→ 930), 5 (→ 931)
50 007 830	RENAULT	9 (→ 978), 11 (→ 979), 12 (→ 980)
	MERCEDES-BENZ	1 (→ 497)
	NISSAN	3 (→ 929), 4 (→ 930), 5 (→ 931)
50 007 831	RENAULT	9 (→ 978), 11 (→ 979), 12 (→ 980)
	MERCEDES-BENZ	1 (→ 497)
	NISSAN	3 (→ 929), 4 (→ 930), 5 (→ 931)
50 007 832	RENAULT	9 (→ 978), 11 (→ 979), 12 (→ 980)
	MERCEDES-BENZ	1 (→ 497)
	NISSAN	3 (→ 929), 4 (→ 930), 5 (→ 931)
50 007 833	RENAULT	9 (→ 978), 11 (→ 979), 12 (→ 980)
	MERCEDES-BENZ	1 (→ 497)
	NISSAN	3 (→ 929), 4 (→ 930), 5 (→ 931)
50 007 834	RENAULT	9 (→ 978), 11 (→ 979), 12 (→ 980)
	MERCEDES-BENZ	1 (→ 497)
	NISSAN	3 (→ 929), 4 (→ 930), 5 (→ 931)
50 007 835	RENAULT	9 (→ 978), 11 (→ 979), 12 (→ 980)
	MERCEDES-BENZ	1 (→ 497)
	NISSAN	3 (→ 929), 4 (→ 930), 5 (→ 931)
50 007 836	RENAULT	9 (→ 978), 11 (→ 979), 12 (→ 980)
	MERCEDES-BENZ	1 (→ 497)
	NISSAN	3 (→ 929), 4 (→ 930), 5 (→ 931)
50 007 838	RENAULT	9 (→ 978), 11 (→ 979), 12 (→ 980)
	MERCEDES-BENZ	1 (→ 497)
	NISSAN	3 (→ 929), 4 (→ 930), 5 (→ 931)
50 007 839	RENAULT	9 (→ 978), 11 (→ 979), 12 (→ 980)
	MERCEDES-BENZ	1 (→ 497)
	NISSAN	3 (→ 929), 4 (→ 930), 5 (→ 931)
50 007 840	RENAULT	9 (→ 978), 11 (→ 979), 12 (→ 980)
	MERCEDES-BENZ	1 (→ 497)
	NISSAN	3 (→ 929), 4 (→ 930), 5 (→ 931)
50 007 841	RENAULT	9 (→ 978), 11 (→ 979), 12 (→ 980)
	MERCEDES-BENZ	1 (→ 497)
	NISSAN	3 (→ 929), 4 (→ 930), 5 (→ 931)
50 007 842	RENAULT	9 (→ 978), 11 (→ 979), 12 (→ 980)
	MERCEDES-BENZ	1 (→ 497)
	NISSAN	3 (→ 929), 4 (→ 930), 5 (→ 931)
50 007 843	RENAULT	9 (→ 978), 11 (→ 979), 12 (→ 980)
	MERCEDES-BENZ	1 (→ 497)
	NISSAN	3 (→ 929), 4 (→ 930), 5 (→ 931)
50 007 844	RENAULT	9 (→ 978), 11 (→ 979), 12 (→ 980)
	MERCEDES-BENZ	1 (→ 497)
	NISSAN	3 (→ 929), 4 (→ 930), 5 (→ 931)
50 007 845	RENAULT	9 (→ 978), 11 (→ 979), 12 (→ 980)
	MERCEDES-BENZ	1 (→ 497)
	NISSAN	3 (→ 929), 4 (→ 930), 5 (→ 931)
50 007 846	RENAULT	9 (→ 978), 11 (→ 979), 12 (→ 980)
	MERCEDES-BENZ	1 (→ 497)
	NISSAN	3 (→ 929), 4 (→ 930), 5 (→ 931)
50 007 847	RENAULT	9 (→ 978), 11 (→ 979), 12 (→ 980)
	MERCEDES-BENZ	1 (→ 497)
	NISSAN	3 (→ 929), 4 (→ 930), 5 (→ 931)
	RENAULT	9 (→ 978), 11 (→ 979), 12 (→ 980)
20100225010	MERCEDES-BENZ	315 (→ 664), 324 (→ 669), ... , 507 (→ 857), 541 (→ 903)
20100336602	FORD	145 (→ 344)

Item No.	Type	Pos (→  )
		MERCEDES-BENZ 129 (→ 546), 130 (→ 547), ... , 235 (→ 614), 236 (→ 615)
20100340010	MERCEDES-BENZ	315 (→ 664), 323 (→ 668), ... , 509 (→ 860), 541 (→ 903)
20100340012	MERCEDES-BENZ	315 (→ 664), 323 (→ 668), ... , 509 (→ 860), 541 (→ 903)
20100347110	MERCEDES-BENZ	556 (→ 915), 557 (→ 915), ... , 565 (→ 918), 566 (→ 918)
20100347111	MERCEDES-BENZ	341 (→ 691), 350 (→ 700), ... , 568 (→ 918), 569 (→ 918)
20100347112	MERCEDES-BENZ	341 (→ 691), 350 (→ 700), ... , 565 (→ 918), 566 (→ 918)
20100350010	MERCEDES-BENZ	437 (→ 788), 440 (→ 792), ... , 554 (→ 914), 555 (→ 915)
20100350011	MERCEDES-BENZ	437 (→ 788), 440 (→ 792), ... , 554 (→ 914), 555 (→ 915)
20100412100	VOLVO	136 (→ 1391), 137 (→ 1392), ... , 139 (→ 1394), 140 (→ 1395)
20100412101	VOLVO	136 (→ 1391), 137 (→ 1392), ... , 161 (→ 1409), 167 (→ 1412)
20100412102	VOLVO	136 (→ 1391), 137 (→ 1392), ... , 167 (→ 1412), 168 (→ 1412)
50 006 096	FIAT	77 (→ 236), 80 (→ 237)
	FORD	87 (→ 318), 88 (→ 318), 89 (→ 318)
	LANCIA	39 (→ 361), 40 (→ 361), 42 (→ 362)
50 006 128	BMW	23 (→ 171), 48 (→ 180)
50 006 129	BMW	22 (→ 171), 46 (→ 179), ... , 71 (→ 188), 73 (→ 189)
50 006 132	BMW	16 (→ 169), 59 (→ 184), ... , 67 (→ 187), 68 (→ 187)
	ROVER	13 (→ 1024)
50 006 133	BMW	61 (→ 185), 62 (→ 185), ... , 66 (→ 187), 67 (→ 187)
50 006 140	VOLKSWAGEN	4 (→ 1126), 5 (→ 1126), ... , 67 (→ 1146), 95 (→ 1158)
50 006 141	SKODA	23 (→ 1042), 24 (→ 1043)
	VOLKSWAGEN	2 (→ 1125), 54 (→ 1139), ... , 66 (→ 1145), 251 (→ 1222)
50 006 142	SKODA	19 (→ 1040), 20 (→ 1040), ... , 27 (→ 1044), 29 (→ 1046)
	VOLKSWAGEN	56 (→ 1140), 57 (→ 1141), ... , 75 (→ 1150), 76 (→ 1151)
50 006 143	SKODA	26 (→ 1044), 28 (→ 1045), 32 (→ 1047)
	VOLKSWAGEN	68 (→ 1146), 69 (→ 1147), ... , 79 (→ 1153), 80 (→ 1153)
50 006 144	SKODA	102 (→ 1080)
	VOLKSWAGEN	246 (→ 1220), 362 (→ 1269), ... , 385 (→ 1276), 388 (→ 1277)
50 006 147	SKODA	69 (→ 1064), 70 (→ 1065), 72 (→ 1066), 73 (→ 1066)
	VOLKSWAGEN	252 (→ 1222), 253 (→ 1223), ... , 256 (→ 1224), 257 (→ 1224)
50 006 148	SKODA	90 (→ 1074), 91 (→ 1075), 92 (→ 1075), 93 (→ 1076)
	VOLKSWAGEN	310 (→ 1249), 313 (→ 1251), ... , 317 (→ 1252), 319 (→ 1253)
50 006 149	SKODA	88 (→ 1073), 89 (→ 1074)
	VOLKSWAGEN	307 (→ 1248), 308 (→ 1248), ... , 312 (→ 1250), 314 (→ 1251)
50 006 171	SKODA	57 (→ 1060), 58 (→ 1060), ... , 75 (→ 1067), 81 (→ 1070)
	VOLKSWAGEN	181 (→ 1194), 182 (→ 1195), ... , 358 (→ 1268), 360 (→ 1269)
50 006 172	FORD	13 (→ 297)
50 006 179	SKODA	74 (→ 1067), 79 (→ 1069)
	VOLKSWAGEN	267 (→ 1229), 275 (→ 1234), ... , 277 (→ 1235), 279 (→ 1236)
50 006 410	SKODA	38 (→ 1050)
	VOLKSWAGEN	122 (→ 1168), 123 (→ 1168)
50 006 429	RENAULT	90 (→ 1008), 92 (→ 1008)
50 006 430	FIAT	76 (→ 236), 79 (→ 237)
	LANCIA	37 (→ 360), 38 (→ 361)
50 006 484	FIAT	7 (→ 219), 8 (→ 219), ... , 10 (→ 220), 12 (→ 221)
	LANCIA	3 (→ 352), 4 (→ 353)
50 006 485	FORD	22 (→ 299)
	VOLVO	3 (→ 1337)
50 006 486	NISSAN	13 (→ 934), 19 (→ 935)
	RENAULT	33 (→ 988), 34 (→ 989), ... , 65 (→ 1000), 67 (→ 1000)
50 006 495	MERCEDES-BENZ	47 (→ 512), 95 (→ 535), 127 (→ 545)
50 006 497	MERCEDES-BENZ	47 (→ 512), 95 (→ 535), 127 (→ 545)
50 006 499	MERCEDES-BENZ	47 (→ 512), 95 (→ 535), 127 (→ 545)
50 007 583	SKODA	74 (→ 1067), 79 (→ 1069)
	VOLKSWAGEN	267 (→ 1229), 275 (→ 1234), ... , 277 (→ 1235), 279 (→ 1236)
50 007 584	SKODA	74 (→ 1067), 79 (→ 1069)
	VOLKSWAGEN	267 (→ 1229), 275 (→ 1234), ... , 277 (→ 1235), 279 (→ 1236)
50 007 585	SKODA	74 (→ 1067), 79 (→ 1069)
	VOLKSWAGEN	267 (→ 1229), 275 (→ 1234), ... , 277 (→ 1235), 279 (→ 1236)
50 007 608	FORD	121 (→ 334), 124 (→ 336)
50 007 609	FORD	121 (→ 334), 124 (→ 336)
50 007 610	FORD	104 (→ 325), 105 (→ 325)



KS/TRW/BF No. → Application



KS/TRW/BF No. → Application

Item No.	Type	Pos (→  )
50 007 611	FORD	104 (→ 325), 105 (→ 325)
50 007 612	FIAT	55 (→ 230)
50 007 613	FIAT	55 (→ 230)
50 007 617	BMW	35 (→ 175), 36 (→ 175), 37 (→ 175)
50 007 618	FIAT	47 (→ 227), 48 (→ 227)
50 007 624	FORD	39 (→ 304), 52 (→ 309), ... , 136 (→ 342), 137 (→ 342)
50 007 627	FORD	92 (→ 320), 94 (→ 321)
50 007 628	FORD	92 (→ 320), 94 (→ 321)
50 007 629	FIAT	100 (→ 242), 120 (→ 250), 125 (→ 251)
50 007 641	MERCEDES-BENZ	36 (→ 508), 38 (→ 509), ... , 41 (→ 510), 45 (→ 512)
50 007 642	SKODA	1 (→ 1035)
	VOLKSWAGEN	8 (→ 1126), 9 (→ 1127), 10 (→ 1127)
50 007 643	MERCEDES-BENZ	31 (→ 506)
50 007 650	SKODA	45 (→ 1053), 46 (→ 1054), ... , 78 (→ 1069), 80 (→ 1070)
	VOLKSWAGEN	77 (→ 1152), 156 (→ 1182), ... , 280 (→ 1236), 286 (→ 1239)
50 007 651	FORD	107 (→ 327), 108 (→ 328), ... , 126 (→ 337), 127 (→ 338)
50 007 653	FORD	107 (→ 327), 108 (→ 328), ... , 126 (→ 337), 127 (→ 338)
50 007 657	SKODA	94 (→ 1077), 95 (→ 1077), 99 (→ 1079)
	VOLKSWAGEN	323 (→ 1255), 324 (→ 1255), ... , 340 (→ 1262), 371 (→ 1273)
50 007 658	FIAT	88 (→ 239)
50 007 668	SKODA	3 (→ 1036), 4 (→ 1036), ... , 11 (→ 1037), 16 (→ 1039)
	VOLKSWAGEN	11 (→ 1128), 12 (→ 1128), ... , 24 (→ 1131), 28 (→ 1132)
50 007 711	FIAT	39 (→ 226)
	MERCEDES-BENZ	13 (→ 500)
	NISSAN	18 (→ 935)
	RENAULT	73 (→ 1002), 74 (→ 1003), ... , 78 (→ 1004), 84 (→ 1006)
50 007 810	BMW	6 (→ 166), 63 (→ 186), 64 (→ 186)
50 007 848	FORD	90 (→ 319), 91 (→ 320), 95 (→ 322), 96 (→ 322)
50 007 850	BMW	5 (→ 165), 27 (→ 172), ... , 82 (→ 191), 83 (→ 191)
20080340300	MERCEDES-BENZ	315 (→ 664), 322 (→ 667), ... , 509 (→ 860), 541 (→ 903)
20080340301	MERCEDES-BENZ	315 (→ 664), 322 (→ 667), ... , 509 (→ 860), 541 (→ 903)
20080344000	MERCEDES-BENZ	372 (→ 716), 412 (→ 760), ... , 439 (→ 791), 480 (→ 832)
20080344010	MERCEDES-BENZ	372 (→ 716), 412 (→ 760), ... , 444 (→ 796), 480 (→ 832)
20080350100	MERCEDES-BENZ	510 (→ 862), 512 (→ 864), ... , 526 (→ 888), 543 (→ 905)
20080350101	MERCEDES-BENZ	510 (→ 862), 512 (→ 864), ... , 525 (→ 886), 543 (→ 905)
20080350110	MERCEDES-BENZ	514 (→ 868), 517 (→ 872), ... , 531 (→ 893), 534 (→ 897)
20080350111	MERCEDES-BENZ	514 (→ 868), 517 (→ 872), ... , 531 (→ 893), 534 (→ 897)
20080390602	MERCEDES-BENZ	238 (→ 616), 239 (→ 617), ... , 310 (→ 661), 311 (→ 662)
50 003 069	VOLKSWAGEN	134 (→ 1172)
50 003 097	VOLKSWAGEN	398 (→ 1280)
50 003 101	VOLKSWAGEN	136 (→ 1173)
50 003 107	VOLKSWAGEN	134 (→ 1172), 142 (→ 1176)
50 003 108	VOLKSWAGEN	139 (→ 1175)
50 003 113	VOLKSWAGEN	136 (→ 1173), 154 (→ 1181)
50 003 115	VOLKSWAGEN	259 (→ 1226)
	VOLVO	23 (→ 1342)
50 003 119	MERCEDES-BENZ	69 (→ 521)
50 003 122	MERCEDES-BENZ	73 (→ 523), 75 (→ 524)
50 003 125	MERCEDES-BENZ	71 (→ 522)
50 003 126	MERCEDES-BENZ	36 (→ 508)
50 003 131	FORD	46 (→ 307), 47 (→ 307)
	SKODA	45 (→ 1053), 46 (→ 1054), ... , 77 (→ 1068), 80 (→ 1070)
	VOLKSWAGEN	156 (→ 1182), 157 (→ 1183), ... , 280 (→ 1237), 285 (→ 1239)
50 003 175	NISSAN	37 (→ 939), 39 (→ 939), 42 (→ 940)
50 003 358	VOLKSWAGEN	99 (→ 1159), 102 (→ 1161), ... , 109 (→ 1164), 113 (→ 1165)
50 003 397	VOLKSWAGEN	398 (→ 1280)
50 003 415	VOLKSWAGEN	259 (→ 1226)
	VOLVO	23 (→ 1342)
50 003 419	MERCEDES-BENZ	69 (→ 521)
50 003 425	MERCEDES-BENZ	71 (→ 522)



Item No.	Type	Pos ( →  )	
			
50 003 431		FORD	46 (→ 307), 47 (→ 307)
		SKODA	45 (→ 1053), 46 (→ 1054), ... , 52 (→ 1057), 56 (→ 1059)
		VOLKSWAGEN	156 (→ 1182), 157 (→ 1183), ... , 177 (→ 1192), 178 (→ 1193)

KS/TRW/BF No. → Application

Item No.	Type	Pos ( →  )

# ALPHANUMERICAL LIST

<b>D</b>	<b>ALPHANUMERISCHE LISTE</b>
<b>E</b>	<b>ALPHANUMERICAL LIST</b>
<b>F</b>	<b>LISTE ALPHANUMÉRIQUE</b>
<b>ES</b>	<b>LISTA ALFANUMÉRICA</b>
<b>RU</b>	<b>БУКВЕННО-ЦИФРОВОЙ СПИСОК</b>

# ALPHANUMERICAL LIST

Reference	Item No.	Pos (→  )		
00 03 102 891	RENAULT	81-5115	RENAULT	1 (→ 976), ... , 17 (→ 982)
00 20 905 400	RENAULT	81-47114	RENAULT	122 (→ 1017), ... , 127 (→ 1019)
00 20 905 400	RENAULT	81-47119	RENAULT	122 (→ 1017), ... , 127 (→ 1019)
00A 109 309	VOLKSWAGEN	50 006 421	VOLKSWAGEN	390 (→ 1278)
00A 109 601A	VOLKSWAGEN	26048	VOLKSWAGEN	390 (→ 1278)
021 101 402	VOLKSWAGEN	81-3940	VOLKSWAGEN	389 (→ 1277), ... , 398 (→ 1280)
021 101 403 A	VOLKSWAGEN	81-3941	VOLKSWAGEN	389 (→ 1277), ... , 398 (→ 1280)
021 101 416	VOLKSWAGEN	81-3946	VOLKSWAGEN	389 (→ 1277), ... , 398 (→ 1280)
021 101 417 A	VOLKSWAGEN	81-3946	VOLKSWAGEN	389 (→ 1277), ... , 398 (→ 1280)
021 101 417 A	VOLKSWAGEN	81-3947	VOLKSWAGEN	389 (→ 1277), ... , 398 (→ 1280)
021 109 601	VOLKSWAGEN	33014	VOLKSWAGEN	389 (→ 1277), ... , 395 (→ 1279)
021 109 601 H	VOLKSWAGEN	39372	VOLKSWAGEN	238 (→ 1216), 294 (→ 1242)
021 109 601 J	VOLKSWAGEN	39372	VOLKSWAGEN	238 (→ 1216), 294 (→ 1242)
021 109 601 K	VOLKSWAGEN	39372	VOLKSWAGEN	238 (→ 1216), 294 (→ 1242)
021 109 611 D	VOLKSWAGEN	39300	VOLKSWAGEN	238 (→ 1216), 294 (→ 1242)
021 109 611G	VOLKSWAGEN	331109	VOLKSWAGEN	225 (→ 1211), 233 (→ 1214)
021 109 651	VOLKSWAGEN	MK-7H	VOLKSWAGEN	1 (→ 1125), ... , 404 (→ 1281)
022 109 309	VOLKSWAGEN	50 007 625	VOLKSWAGEN	381 (→ 1275), ... , 399 (→ 1280)
022 109 417 C	VOLKSWAGEN	50 006 144	VOLKSWAGEN	246 (→ 1220), ... , 388 (→ 1277)
022 109 417 E	VOLKSWAGEN	50 006 144	VOLKSWAGEN	246 (→ 1220), ... , 388 (→ 1277)
022 109 423 A	VOLKSWAGEN	50 006 419	VOLKSWAGEN	252 (→ 1222), ... , 370 (→ 1272)
022 109 423 B	VOLKSWAGEN	50 006 491	VOLKSWAGEN	245 (→ 1219), ... , 385 (→ 1276)
022 109 423 C	VOLKSWAGEN	50 006 491	VOLKSWAGEN	245 (→ 1219), ... , 385 (→ 1276)
022 109 423 D	VOLKSWAGEN	50 006 419	VOLKSWAGEN	252 (→ 1222), ... , 370 (→ 1272)
022 109 601 AJ	VOLKSWAGEN	331127	VOLKSWAGEN	364 (→ 1270), ... , 388 (→ 1277)
022 109 601 AK	VOLKSWAGEN	331128	VOLKSWAGEN	364 (→ 1270), ... , 388 (→ 1277)
022 109 601 E	VOLKSWAGEN	331041	VOLKSWAGEN	245 (→ 1219), ... , 368 (→ 1271)
022 109 601F	VOLKSWAGEN	331135	VOLKSWAGEN	245 (→ 1219), ... , 368 (→ 1271)
022 109 601G	VOLKSWAGEN	331127	VOLKSWAGEN	364 (→ 1270), ... , 388 (→ 1277)
022 109 601H	VOLKSWAGEN	331128	VOLKSWAGEN	364 (→ 1270), ... , 388 (→ 1277)
022 109 611 AA	VOLKSWAGEN	331129	VOLKSWAGEN	364 (→ 1270), ... , 388 (→ 1277)
022 109 611 AB	VOLKSWAGEN	331130	VOLKSWAGEN	364 (→ 1270), ... , 388 (→ 1277)
022 109 611 C	VOLKSWAGEN	331042	VOLKSWAGEN	245 (→ 1219), ... , 368 (→ 1271)
022 109 611B	VOLKSWAGEN	331136	VOLKSWAGEN	245 (→ 1219), ... , 368 (→ 1271)
022 109 611M	VOLKSWAGEN	331130	VOLKSWAGEN	364 (→ 1270), ... , 388 (→ 1277)
022 109 611N	VOLKSWAGEN	331129	VOLKSWAGEN	364 (→ 1270), ... , 388 (→ 1277)
022 109 611P	VOLKSWAGEN	331130	VOLKSWAGEN	364 (→ 1270), ... , 388 (→ 1277)
022 109 612 D	VOLKSWAGEN	33012	VOLKSWAGEN	389 (→ 1277), ... , 395 (→ 1279)
025 101 065 C	VOLKSWAGEN	50 003 097	VOLKSWAGEN	398 (→ 1280)
025 101 065 C	VOLKSWAGEN	50 003 397	VOLKSWAGEN	398 (→ 1280)
025 101 355 C	VOLKSWAGEN	50 003 097	VOLKSWAGEN	398 (→ 1280)
025 101 355 C	VOLKSWAGEN	50 003 397	VOLKSWAGEN	398 (→ 1280)
025 109 601	VOLKSWAGEN	39112	VOLKSWAGEN	397 (→ 1279), 398 (→ 1280)
025 109 601C	VOLKSWAGEN	39112	VOLKSWAGEN	397 (→ 1279), 398 (→ 1280)
025 109 612 A	VOLKSWAGEN	3911	VOLKSWAGEN	397 (→ 1279), 398 (→ 1280)
026 109 101M	VOLKSWAGEN	50 006 397	VOLKSWAGEN	190 (→ 1197), ... , 258 (→ 1225)
026 109 601 C	VOLKSWAGEN	39136	VOLKSWAGEN	191 (→ 1198), ... , 209 (→ 1205)
026 109 601 F	VOLKSWAGEN	39136	VOLKSWAGEN	191 (→ 1198), ... , 209 (→ 1205)
026 109 601A	VOLKSWAGEN	39136	VOLKSWAGEN	191 (→ 1198), ... , 209 (→ 1205)
026109101Q	VOLKSWAGEN	50 007 594	VOLKSWAGEN	196 (→ 1200), ... , 231 (→ 1213)
027 109 601 C	VOLKSWAGEN	33125	VOLKSWAGEN	211 (→ 1206), 296 (→ 1242)
027 109 611 B	VOLKSWAGEN	33050	VOLKSWAGEN	211 (→ 1206), 296 (→ 1242)
027 109 611 C	VOLKSWAGEN	33050	VOLKSWAGEN	211 (→ 1206), 296 (→ 1242)
027 109 611 D	VOLKSWAGEN	33050	VOLKSWAGEN	211 (→ 1206), 296 (→ 1242)
027 109 651	VOLKSWAGEN	RK-7H	VOLKSWAGEN	211 (→ 1206), ... , 403 (→ 1281)
028 103 351	VOLKSWAGEN	50 003 069	VOLKSWAGEN	134 (→ 1172)
028 103 351 D	VOLKSWAGEN	50 003 069	VOLKSWAGEN	134 (→ 1172)
028 103 351 L	VOLKSWAGEN	50 003 108	VOLKSWAGEN	139 (→ 1175)
028 103 351 M	VOLKSWAGEN	50 003 107	VOLKSWAGEN	134 (→ 1172), 142 (→ 1176)
028 109 101 D	VOLKSWAGEN	50 006 203	VOLKSWAGEN	134 (→ 1171), ... , 168 (→ 1187)
028 109 101 E	VOLKSWAGEN	50 006 204	VOLKSWAGEN	144 (→ 1177), ... , 148 (→ 1178)
028 109 101 F	VOLKSWAGEN	50 006 205	VOLKSWAGEN	138 (→ 1174), ... , 152 (→ 1180)
028 109 101 G	VOLKSWAGEN	50 006 203	VOLKSWAGEN	134 (→ 1171), ... , 168 (→ 1187)
028 109 601 B	VOLKSWAGEN	39395	VOLKSWAGEN	134 (→ 1171), ... , 168 (→ 1187)
028 109 601 D	FORD	39486	FORD	44 (→ 306), 45 (→ 306)

Reference	Item No.	Pos (→  )		
028 109 601 D	SKODA	39486	SKODA	41 (→ 1051), 42 (→ 1051)
028 109 601 D	VOLKSWAGEN	39486	VOLKSWAGEN	138 (→ 1174), ... , 187 (→ 1196)
028 109 601 H	VOLKSWAGEN	39423	VOLKSWAGEN	138 (→ 1174), ... , 283 (→ 1238)
028 109 601 J	SKODA	39502	SKODA	40 (→ 1051), ... , 44 (→ 1052)
028 109 601 J	VOLKSWAGEN	39502	VOLKSWAGEN	144 (→ 1177), ... , 188 (→ 1197)
028 109 601A	VOLKSWAGEN	39423	VOLKSWAGEN	138 (→ 1174), ... , 283 (→ 1238)
028 109 611 E	VOLKSWAGEN	39474	VOLKSWAGEN	134 (→ 1171), ... , 168 (→ 1187)
028 109 611 K	SKODA	39503	SKODA	40 (→ 1051), ... , 44 (→ 1052)
028 109 611 K	VOLKSWAGEN	39503	VOLKSWAGEN	144 (→ 1177), ... , 188 (→ 1197)
028 109 611G	VOLKSWAGEN	331143	VOLKSWAGEN	138 (→ 1174), ... , 187 (→ 1196)
028109601H	FORD	39423	FORD	44 (→ 306)
030 109 101 AM	VOLKSWAGEN	50 006 380	VOLKSWAGEN	49 (→ 1138)
030 109 101 BG	VOLKSWAGEN	50 006 381	VOLKSWAGEN	1 (→ 1125)
030 109 411	VOLKSWAGEN	50 006 140	VOLKSWAGEN	4 (→ 1126), ... , 95 (→ 1158)
030 109 411B	VOLKSWAGEN	50 006 140	VOLKSWAGEN	4 (→ 1126), ... , 95 (→ 1158)
030 109 417 D	VOLKSWAGEN	50 006 141	VOLKSWAGEN	2 (→ 1125), ... , 251 (→ 1222)
030 109 423	VOLKSWAGEN	50 006 415	VOLKSWAGEN	2 (→ 1125), ... , 251 (→ 1222)
030 109 423 A	VOLKSWAGEN	50 006 415	VOLKSWAGEN	2 (→ 1125), ... , 251 (→ 1222)
030 109 423 B	VOLKSWAGEN	50 006 415	VOLKSWAGEN	2 (→ 1125), ... , 251 (→ 1222)
030 109 601	VOLKSWAGEN	39262	VOLKSWAGEN	43 (→ 1136), 44 (→ 1136)
030 109 601 AG	VOLKSWAGEN	39542	VOLKSWAGEN	1 (→ 1125)
030 109 601 AH	VOLKSWAGEN	39530	VOLKSWAGEN	49 (→ 1138), ... , 53 (→ 1139)
030 109 601 B	VOLKSWAGEN	33046	VOLKSWAGEN	29 (→ 1132), ... , 94 (→ 1158)
030 109 601 C	VOLKSWAGEN	33046	VOLKSWAGEN	29 (→ 1132), ... , 94 (→ 1158)
030 109 601 D	VOLKSWAGEN	33046	VOLKSWAGEN	29 (→ 1132), ... , 94 (→ 1158)
030 109 601 F	VOLKSWAGEN	33046	VOLKSWAGEN	29 (→ 1132), ... , 94 (→ 1158)
030 109 601 G	VOLKSWAGEN	39360	VOLKSWAGEN	41 (→ 1135), 44 (→ 1136)
030 109 601AK	VOLKSWAGEN	331139	VOLKSWAGEN	2 (→ 1125), 3 (→ 1125)
030 109 601N	VOLKSWAGEN	390058	VOLKSWAGEN	39 (→ 1135), 42 (→ 1136)
030 109 611 N	VOLKSWAGEN	39515	VOLKSWAGEN	1 (→ 1125)
030 109 611S	VOLKSWAGEN	331140	VOLKSWAGEN	2 (→ 1125), 3 (→ 1125)
030109601AH	SKODA	39530	SKODA	18 (→ 1039)
030109601AL	VOLKSWAGEN	331046	VOLKSWAGEN	54 (→ 1139), 59 (→ 1142)
030109611T	VOLKSWAGEN	331047	VOLKSWAGEN	54 (→ 1139), ... , 95 (→ 1158)
032 109 101 S	VOLKSWAGEN	50 006 382	VOLKSWAGEN	53 (→ 1139)
032 109 601 G	VOLKSWAGEN	39367	VOLKSWAGEN	50 (→ 1138)
032 109 601L	VOLKSWAGEN	331137	VOLKSWAGEN	63 (→ 1144), ... , 95 (→ 1158)
032 109 601M	VOLKSWAGEN	331137	VOLKSWAGEN	63 (→ 1144), ... , 95 (→ 1158)
032 109 611 G	VOLKSWAGEN	39467	VOLKSWAGEN	49 (→ 1138), ... , 53 (→ 1139)
032 109 611L	VOLKSWAGEN	331047	VOLKSWAGEN	54 (→ 1139), ... , 95 (→ 1158)
032 109 611M	VOLKSWAGEN	331047	VOLKSWAGEN	54 (→ 1139), ... , 95 (→ 1158)
032109611G	SKODA	39467	SKODA	18 (→ 1039)
034 109 309	VOLKSWAGEN	50 006 460	VOLKSWAGEN	29 (→ 1132), ... , 300 (→ 1245)
034 109 309 AC	VOLKSWAGEN	50 006 460	VOLKSWAGEN	29 (→ 1132), ... , 300 (→ 1245)
034 109 309 AD	VOLKSWAGEN	50 006 460	VOLKSWAGEN	29 (→ 1132), ... , 300 (→ 1245)
034 109 309 N	VOLKSWAGEN	50 006 460	VOLKSWAGEN	29 (→ 1132), ... , 300 (→ 1245)
035 109 601 C	VOLKSWAGEN	33022	VOLKSWAGEN	130 (→ 1170), ... , 258 (→ 1225)
035 109 601 J	VOLKSWAGEN	33282	VOLKSWAGEN	191 (→ 1198), ... , 229 (→ 1212)
035 109 601 K	VOLKSWAGEN	33282	VOLKSWAGEN	191 (→ 1198), ... , 229 (→ 1212)
035 109 611 F	VOLKSWAGEN	33023	VOLKSWAGEN	130 (→ 1170), ... , 258 (→ 1225)
036 109 101 AA	VOLKSWAGEN	50 006 155	VOLKSWAGEN	56 (→ 1140), ... , 85 (→ 1155)
036 109 101 AC	VOLKSWAGEN	50 006 156	VOLKSWAGEN	56 (→ 1140)
036 109 101 DG	VOLKSWAGEN	50 006 156	VOLKSWAGEN	56 (→ 1140)
036 109 101AG	VOLKSWAGEN	50 007 637	VOLKSWAGEN	58 (→ 1141), 60 (→ 1142)
036 109 101DH	VOLKSWAGEN	50 007 636	VOLKSWAGEN	58 (→ 1141), 60 (→ 1142)
036 109 309 D	VOLKSWAGEN	50 006 138	VOLKSWAGEN	55 (→ 1140)
036 109 309 F	VOLKSWAGEN	50 006 138	VOLKSWAGEN	55 (→ 1140)
036 109 411	VOLKSWAGEN	50 006 142	VOLKSWAGEN	56 (→ 1140), ... , 76 (→ 1151)
036 109 411 C	VOLKSWAGEN	50 006 142	VOLKSWAGEN	56 (→ 1140), ... , 76 (→ 1151)
036 109 411 D	VOLKSWAGEN	50 006 142	VOLKSWAGEN	56 (→ 1140), ... , 76 (→ 1151)
036 109 411 E	VOLKSWAGEN	50 006 143	VOLKSWAGEN	68 (→ 1146), ... , 80 (→ 1153)
036 109 411 H	VOLKSWAGEN	50 006 143	VOLKSWAGEN	68 (→ 1146), ... , 80 (→ 1153)
036 109 423 A	VOLKSWAGEN	50 006 415	VOLKSWAGEN	2 (→ 1125), ... , 251 (→ 1222)
036 109 423 D	VOLKSWAGEN	50 006 415	VOLKSWAGEN	2 (→ 1125), ... , 251 (→ 1222)
036 109 601 AD	VOLKSWAGEN	39522	VOLKSWAGEN	56 (→ 1140), ... , 91 (→ 1157)

# ALPHANUMERICAL LIST

Reference	Item No.	Pos (→  )
036 109 601 AK VOLKSWAGEN	39522	VOLKSWAGEN 56 (→ 1140), ... , 91 (→ 1157)
036 109 601 AL VOLKSWAGEN	39522	VOLKSWAGEN 56 (→ 1140), ... , 91 (→ 1157)
036 109 601 S VOLKSWAGEN	39522	VOLKSWAGEN 56 (→ 1140), ... , 91 (→ 1157)
036 109 611 VOLKSWAGEN	331104	VOLKSWAGEN 32 (→ 1133), ... , 35 (→ 1133)
036 109 611 AE VOLKSWAGEN	39523	VOLKSWAGEN 56 (→ 1140), ... , 91 (→ 1157)
036 109 611 K SKODA	39523	SKODA 19 (→ 1039), ... , 36 (→ 1049)
036 109 611 K VOLKSWAGEN	39523	VOLKSWAGEN 56 (→ 1140), ... , 91 (→ 1157)
036109601S SKODA	39522	SKODA 19 (→ 1039), ... , 36 (→ 1049)
038 103 351 D VOLKSWAGEN	50 003 131	VOLKSWAGEN 156 (→ 1182), ... , 285 (→ 1239)
038 109 101 AE VOLKSWAGEN	50 007 582	VOLKSWAGEN 270 (→ 1230)
038 109 101 AF VOLKSWAGEN	50 006 343	VOLKSWAGEN 269 (→ 1230)
038 109 101 AH VOLKSWAGEN	50 006 342	VOLKSWAGEN 162 (→ 1185), ... , 280 (→ 1236)
038 109 101 E VOLKSWAGEN	50 006 210	VOLKSWAGEN 147 (→ 1178), 155 (→ 1181)
038 109 101 K VOLKSWAGEN	50 006 202	VOLKSWAGEN 150 (→ 1179), ... , 187 (→ 1197)
038 109 101 R VOLKSWAGEN	50 006 304	VOLKSWAGEN 156 (→ 1182), ... , 178 (→ 1193)
038 109 309 A VOLKSWAGEN	50 006 418	VOLKSWAGEN 116 (→ 1166), ... , 293 (→ 1242)
038 109 309 B VOLKSWAGEN	50 006 418	VOLKSWAGEN 116 (→ 1166), ... , 293 (→ 1242)
038 109 309 C VOLKSWAGEN	50 006 418	VOLKSWAGEN 116 (→ 1166), ... , 293 (→ 1242)
038 109 601 B VOLKSWAGEN	331033	VOLKSWAGEN 156 (→ 1182), ... , 268 (→ 1229)
038 109 601 E VOLKSWAGEN	331123	VOLKSWAGEN 158 (→ 1183), ... , 285 (→ 1238)
038 109 601F VOLKSWAGEN	331147	VOLKSWAGEN 163 (→ 1186)
038 109 611 B VOLKSWAGEN	331034	VOLKSWAGEN 156 (→ 1182), ... , 268 (→ 1229)
038 109 611 E VOLKSWAGEN	331124	VOLKSWAGEN 158 (→ 1183), ... , 285 (→ 1238)
038 109 611 F VOLKSWAGEN	331034	VOLKSWAGEN 156 (→ 1182), ... , 268 (→ 1229)
038109527AF VOLKSWAGEN	50 007 650	VOLKSWAGEN 77 (→ 1152), ... , 286 (→ 1239)
038109601B FORD	331033	FORD 46 (→ 306), 47 (→ 307)
038109601B SKODA	331033	SKODA 45 (→ 1053), ... , 56 (→ 1059)
038109611B FORD	331034	FORD 46 (→ 306), 47 (→ 307)
038109611B SKODA	331034	SKODA 45 (→ 1053), ... , 49 (→ 1055)
03C 109 101 AC VOLKSWAGEN	50 007 039	VOLKSWAGEN 70 (→ 1147)
03C 109 101 AD VOLKSWAGEN	50 007 040	VOLKSWAGEN 70 (→ 1147)
03C 109 101 AF VOLKSWAGEN	50 007 035	VOLKSWAGEN 69 (→ 1147)
03C 109 101 AH VOLKSWAGEN	50 007 681	VOLKSWAGEN 71 (→ 1148)
03C 109 101 AS VOLKSWAGEN	50 007 680	VOLKSWAGEN 71 (→ 1148)
03C 109 101 AT VOLKSWAGEN	50 007 034	VOLKSWAGEN 69 (→ 1147)
03C 109 101 CG SKODA	50 007 678	SKODA 22 (→ 1041), 29 (→ 1045)
03C 109 101 CG VOLKSWAGEN	50 007 678	VOLKSWAGEN 75 (→ 1150), ... , 85 (→ 1155)
03C 109 101 CP VOLKSWAGEN	50 007 025	VOLKSWAGEN 84 (→ 1155), 88 (→ 1157)
03C 109 101 CQ VOLKSWAGEN	50 007 026	VOLKSWAGEN 84 (→ 1155), 88 (→ 1157)
03C 109 101 DC VOLKSWAGEN	50 007 018	VOLKSWAGEN 72 (→ 1148), ... , 96 (→ 1159)
03C 109 101 DF VOLKSWAGEN	50 007 019	VOLKSWAGEN 73 (→ 1149), ... , 96 (→ 1159)
03C 109 101 EC SKODA	50 007 678	SKODA 22 (→ 1041), 29 (→ 1045)
03C 109 101 EC VOLKSWAGEN	50 007 678	VOLKSWAGEN 75 (→ 1150), ... , 85 (→ 1155)
03C 109 101 ED VOLKSWAGEN	50 007 679	VOLKSWAGEN 75 (→ 1150), 76 (→ 1151)
03C 109 601 J VOLKSWAGEN	39522	VOLKSWAGEN 56 (→ 1140), ... , 91 (→ 1157)
03C 109 601 M SKODA	39522	SKODA 19 (→ 1039), ... , 36 (→ 1049)
03C 109 601 M VOLKSWAGEN	39522	VOLKSWAGEN 56 (→ 1140), ... , 91 (→ 1157)
03C 109 611 G VOLKSWAGEN	39523	VOLKSWAGEN 56 (→ 1140), ... , 91 (→ 1157)
03C 109 611 R SKODA	39523	SKODA 19 (→ 1039), ... , 36 (→ 1049)
03C 109 611 R VOLKSWAGEN	39523	VOLKSWAGEN 56 (→ 1140), ... , 91 (→ 1157)
03C 109 612 VOLKSWAGEN	39523	VOLKSWAGEN 56 (→ 1140), ... , 91 (→ 1157)
03C109101DE VOLKSWAGEN	50 007 656	VOLKSWAGEN 74 (→ 1150)
03D 109 601B VOLKSWAGEN	331137	VOLKSWAGEN 63 (→ 1144), ... , 95 (→ 1158)
03D 109 611A VOLKSWAGEN	331047	VOLKSWAGEN 54 (→ 1139), ... , 95 (→ 1158)
03E109101AA VOLKSWAGEN	50 007 655	VOLKSWAGEN 64 (→ 1144), 91 (→ 1158)
03E109101T VOLKSWAGEN	50 007 654	VOLKSWAGEN 64 (→ 1144), 91 (→ 1158)
03F 109 101 D SKODA	50 007 677	SKODA 1 (→ 1035)
03F 109 101 D VOLKSWAGEN	50 007 677	VOLKSWAGEN 8 (→ 1126), 9 (→ 1127)
03F 109 601A SKODA	331153	SKODA 1 (→ 1035)
03F 109 601A VOLKSWAGEN	331153	VOLKSWAGEN 8 (→ 1126), ... , 10 (→ 1127)
03F 109 611B SKODA	331155	SKODA 1 (→ 1035)
03F 109 611B VOLKSWAGEN	331155	VOLKSWAGEN 8 (→ 1126), ... , 10 (→ 1127)
03F 109 611C SKODA	331155	SKODA 1 (→ 1035)
03F 109 611C VOLKSWAGEN	331155	VOLKSWAGEN 8 (→ 1126), ... , 10 (→ 1127)
03F109411 VOLKSWAGEN	50 007 642	VOLKSWAGEN 8 (→ 1126), ... , 10 (→ 1127)



# ALPHANUMERICAL LIST

Reference	Item No.	Pos (→  )		
03G 103 351 C	VOLKSWAGEN	50 003 131	VOLKSWAGEN	156 (→ 1182), ... , 285 (→ 1239)
03G 103 351 D	VOLKSWAGEN	50 003 131	VOLKSWAGEN	156 (→ 1182), ... , 285 (→ 1239)
03G 109 101 B	VOLKSWAGEN	50 007 575	VOLKSWAGEN	267 (→ 1229), ... , 366 (→ 1271)
03G 109 101A	VOLKSWAGEN	50 007 575	VOLKSWAGEN	267 (→ 1229), ... , 366 (→ 1271)
03G 109 102 F	VOLKSWAGEN	50 007 578	VOLKSWAGEN	276 (→ 1234), 277 (→ 1235)
03G 109 102B	VOLKSWAGEN	50 007 576	VOLKSWAGEN	267 (→ 1229), ... , 366 (→ 1271)
03G 109 411	VOLKSWAGEN	50 007 583	VOLKSWAGEN	267 (→ 1229), ... , 279 (→ 1236)
03G 109 411 A	VOLKSWAGEN	50 007 584	VOLKSWAGEN	267 (→ 1229), ... , 279 (→ 1236)
03G 109 412	VOLKSWAGEN	50 006 179	VOLKSWAGEN	267 (→ 1229), ... , 279 (→ 1236)
03G 109 412 A	VOLKSWAGEN	50 007 585	VOLKSWAGEN	267 (→ 1229), ... , 279 (→ 1236)
03G 109 601A	VOLKSWAGEN	331119	VOLKSWAGEN	267 (→ 1229), ... , 279 (→ 1236)
03G 109 601B	VOLKSWAGEN	331121	VOLKSWAGEN	267 (→ 1229), ... , 279 (→ 1236)
03G 109 611B	VOLKSWAGEN	331120	VOLKSWAGEN	267 (→ 1229), ... , 279 (→ 1236)
03G 109 611D	VOLKSWAGEN	331122	VOLKSWAGEN	267 (→ 1229), ... , 279 (→ 1236)
03G109411B	VOLKSWAGEN	50 007 583	VOLKSWAGEN	267 (→ 1229), ... , 279 (→ 1236)
03G109411C	VOLKSWAGEN	50 007 584	VOLKSWAGEN	267 (→ 1229), ... , 279 (→ 1236)
03G109412B	VOLKSWAGEN	50 006 179	VOLKSWAGEN	267 (→ 1229), ... , 279 (→ 1236)
03G109412C	VOLKSWAGEN	50 007 585	VOLKSWAGEN	267 (→ 1229), ... , 279 (→ 1236)
03H 109 611D	VOLKSWAGEN	331129	VOLKSWAGEN	364 (→ 1270), ... , 388 (→ 1277)
03H 109 611E	VOLKSWAGEN	331130	VOLKSWAGEN	364 (→ 1270), ... , 388 (→ 1277)
03L 109 021	VOLKSWAGEN	50 007 020	VOLKSWAGEN	181 (→ 1194), ... , 288 (→ 1240)
03L 109 021 D	VOLKSWAGEN	50 007 020	VOLKSWAGEN	181 (→ 1194), ... , 288 (→ 1240)
03L 109 021 E	VOLKSWAGEN	50 007 020	VOLKSWAGEN	181 (→ 1194), ... , 288 (→ 1240)
03L 109 022	VOLKSWAGEN	50 007 022	VOLKSWAGEN	181 (→ 1194), ... , 288 (→ 1240)
03L 109 022 D	VOLKSWAGEN	50 007 022	VOLKSWAGEN	181 (→ 1194), ... , 288 (→ 1240)
03L 109 521	VOLKSWAGEN	50 006 490	VOLKSWAGEN	181 (→ 1194), ... , 360 (→ 1269)
03L 109 521 A	VOLKSWAGEN	50 006 490	VOLKSWAGEN	181 (→ 1194), ... , 360 (→ 1269)
03L 109 601	VOLKSWAGEN	331131	VOLKSWAGEN	185 (→ 1196), ... , 360 (→ 1269)
03L 109 601A	VOLKSWAGEN	331151	VOLKSWAGEN	181 (→ 1194), ... , 186 (→ 1196)
03L 109 611	VOLKSWAGEN	331132	VOLKSWAGEN	185 (→ 1196), ... , 360 (→ 1269)
03L 109 611A	VOLKSWAGEN	331154	VOLKSWAGEN	181 (→ 1194), ... , 359 (→ 1268)
03P 109 021	SKODA	50 007 675	SKODA	58 (→ 1060)
03P 109 021	VOLKSWAGEN	50 007 675	VOLKSWAGEN	183 (→ 1195)
03P 109 022	SKODA	50 007 676	SKODA	58 (→ 1060)
03P 109 022	VOLKSWAGEN	50 007 676	VOLKSWAGEN	183 (→ 1195)
043 101 417 C	VOLKSWAGEN	81-3956	VOLKSWAGEN	118 (→ 1167), ... , 380 (→ 1275)
043 109 611	VOLKSWAGEN	33016	VOLKSWAGEN	118 (→ 1166), ... , 380 (→ 1275)
045 109 101 C	VOLKSWAGEN	50 006 388	VOLKSWAGEN	158 (→ 1183), 166 (→ 1187)
045 109 601	VOLKSWAGEN	331049	VOLKSWAGEN	116 (→ 1166)
045 109 611	VOLKSWAGEN	331050	VOLKSWAGEN	116 (→ 1166)
045109101J	VOLKSWAGEN	50 007 633	VOLKSWAGEN	176 (→ 1192)
046 109 101K	VOLKSWAGEN	50 006 283	VOLKSWAGEN	259 (→ 1226), ... , 281 (→ 1237)
046 109 601G	VOLKSWAGEN	39423	VOLKSWAGEN	138 (→ 1174), ... , 283 (→ 1238)
046 109 601J	VOLKSWAGEN	39423	VOLKSWAGEN	138 (→ 1174), ... , 283 (→ 1238)
046 109 611 C	VOLKSWAGEN	331142	VOLKSWAGEN	138 (→ 1174), ... , 283 (→ 1238)
046 109 611 E	VOLKSWAGEN	331142	VOLKSWAGEN	138 (→ 1174), ... , 283 (→ 1238)
046 109 611 F	VOLKSWAGEN	331142	VOLKSWAGEN	138 (→ 1174), ... , 283 (→ 1238)
048 109 601 A	VOLKSWAGEN	33313	VOLKSWAGEN	192 (→ 1198), ... , 300 (→ 1244)
048 109 611 A	VOLKSWAGEN	33048	VOLKSWAGEN	190 (→ 1197), ... , 299 (→ 1244)
048 109 611B	SKODA	33416	SKODA	65 (→ 1062), ... , 86 (→ 1072)
048 109 611B	VOLKSWAGEN	33416	VOLKSWAGEN	221 (→ 1209), ... , 346 (→ 1263)
049 109 601J	VOLKSWAGEN	39423	VOLKSWAGEN	138 (→ 1174), ... , 283 (→ 1238)
049 109 611 F	VOLKSWAGEN	33025	VOLKSWAGEN	30 (→ 1132), ... , 131 (→ 1171)
04C 109 601C	VOLKSWAGEN	398000	VOLKSWAGEN	20 (→ 1130), ... , 92 (→ 1158)
04C 109 611A	VOLKSWAGEN	398001	VOLKSWAGEN	20 (→ 1130), ... , 92 (→ 1158)
04C 109 611C	VOLKSWAGEN	331164	VOLKSWAGEN	17 (→ 1129), ... , 27 (→ 1131)
04E 109 601	SKODA	398000	SKODA	10 (→ 1037), ... , 37 (→ 1049)
04E 109 601	VOLKSWAGEN	398000	VOLKSWAGEN	20 (→ 1130), ... , 92 (→ 1158)
04E 109 601 P	VOLKSWAGEN	331163	VOLKSWAGEN	17 (→ 1129), ... , 25 (→ 1131)
04E 109 601A	VOLKSWAGEN	331156	VOLKSWAGEN	11 (→ 1127), ... , 16 (→ 1129)
04E 109 601B	VOLKSWAGEN	331158	VOLKSWAGEN	18 (→ 1129), ... , 317 (→ 1252)
04E 109 611AC	VOLKSWAGEN	331164	VOLKSWAGEN	17 (→ 1129), ... , 27 (→ 1131)
04E 109 611AJ	VOLKSWAGEN	331164	VOLKSWAGEN	17 (→ 1129), ... , 27 (→ 1131)
04E 109 611H	VOLKSWAGEN	331159	VOLKSWAGEN	19 (→ 1129), ... , 317 (→ 1252)
04E 109 611J	VOLKSWAGEN	331159	VOLKSWAGEN	19 (→ 1129), ... , 317 (→ 1252)

# ALPHANUMERICAL LIST

Reference	Item No.	Pos (→  )
04E 109 611K	VOLKSWAGEN	331157 VOLKSWAGEN 11 (→ 1127), ... , 16 (→ 1129)
04E 109 611L	VOLKSWAGEN	398001 VOLKSWAGEN 20 (→ 1130), ... , 92 (→ 1158)
04E109411AA	SKODA	50 007 668 SKODA 3 (→ 1036), ... , 16 (→ 1039)
04E109411AA	VOLKSWAGEN	50 007 668 VOLKSWAGEN 11 (→ 1128), ... , 28 (→ 1132)
04E109411J	SKODA	50 007 668 SKODA 3 (→ 1036), ... , 16 (→ 1039)
04E109411J	VOLKSWAGEN	50 007 668 VOLKSWAGEN 11 (→ 1128), ... , 28 (→ 1132)
04E109423C	SKODA	50 007 667 SKODA 2 (→ 1035), ... , 16 (→ 1038)
04E109423C	VOLKSWAGEN	50 007 667 VOLKSWAGEN 11 (→ 1128), ... , 333 (→ 1258)
04L 106 611	VOLKSWAGEN	331166 VOLKSWAGEN 292 (→ 1241)
04L 109 601 H	VOLKSWAGEN	331165 VOLKSWAGEN 292 (→ 1241)
04L 109 601A	VOLKSWAGEN	331151 VOLKSWAGEN 181 (→ 1194), ... , 186 (→ 1196)
04L 109 601B	VOLKSWAGEN	331131 VOLKSWAGEN 185 (→ 1196), ... , 360 (→ 1269)
04L 109 611A	VOLKSWAGEN	331154 VOLKSWAGEN 181 (→ 1194), ... , 359 (→ 1268)
04L 109 611B	VOLKSWAGEN	331132 VOLKSWAGEN 185 (→ 1196), ... , 360 (→ 1269)
04L 109 611C	VOLKSWAGEN	331132 VOLKSWAGEN 185 (→ 1196), ... , 360 (→ 1269)
050 109 101A	VOLKSWAGEN	50 006 398 VOLKSWAGEN 234 (→ 1215), ... , 304 (→ 1246)
050 109 309	VOLKSWAGEN	50 006 417 VOLKSWAGEN 1 (→ 1125), ... , 305 (→ 1247)
050 109 309 A	VOLKSWAGEN	50 006 417 VOLKSWAGEN 1 (→ 1125), ... , 305 (→ 1247)
050 109 309 H	VOLKSWAGEN	50 006 417 VOLKSWAGEN 1 (→ 1125), ... , 305 (→ 1247)
050 109 309 J	VOLKSWAGEN	50 006 417 VOLKSWAGEN 1 (→ 1125), ... , 305 (→ 1247)
051 109 022	VOLKSWAGEN	50 006 306 VOLKSWAGEN 298 (→ 1243)
051 109 022 B	VOLKSWAGEN	50 006 306 VOLKSWAGEN 298 (→ 1243)
051 109 601 B	VOLKSWAGEN	33308 VOLKSWAGEN 298 (→ 1243)
053 109 611	VOLKSWAGEN	33048 VOLKSWAGEN 190 (→ 1197), ... , 299 (→ 1244)
056 109 311 A	VOLKSWAGEN	50 007 621 VOLKSWAGEN 30 (→ 1133), ... , 258 (→ 1225)
056 109 651	VOLKSWAGEN	RK-8 VOLKSWAGEN 7 (→ 1126), ... , 103 (→ 1161)
058 109 021 B	VOLKSWAGEN	50 006 307 VOLKSWAGEN 239 (→ 1217), 251 (→ 1222)
058 109 021 M	VOLKSWAGEN	50 007 581 VOLKSWAGEN 243 (→ 1219), 248 (→ 1220)
058 109 021K	VOLKSWAGEN	50 007 579 VOLKSWAGEN 237 (→ 1216)
058 109 022 B	VOLKSWAGEN	50 006 308 VOLKSWAGEN 239 (→ 1217), ... , 251 (→ 1222)
058 109 022 C	VOLKSWAGEN	50 007 580 VOLKSWAGEN 237 (→ 1216), 240 (→ 1217)
058 109 309 A	VOLKSWAGEN	50 006 426 VOLKSWAGEN 237 (→ 1216), ... , 302 (→ 1246)
058 109 309 B	VOLKSWAGEN	50 006 425 VOLKSWAGEN 237 (→ 1216), ... , 302 (→ 1246)
058 109 309 E	VOLKSWAGEN	50 006 426 VOLKSWAGEN 237 (→ 1216), ... , 302 (→ 1246)
058 109 309 F	VOLKSWAGEN	50 006 425 VOLKSWAGEN 237 (→ 1216), ... , 302 (→ 1246)
058 109 309 J	VOLKSWAGEN	50 006 425 VOLKSWAGEN 237 (→ 1216), ... , 302 (→ 1246)
058 109 309 K	VOLKSWAGEN	50 006 426 VOLKSWAGEN 237 (→ 1216), ... , 302 (→ 1246)
058 109 601 C	VOLKSWAGEN	33413 VOLKSWAGEN 237 (→ 1216), ... , 302 (→ 1245)
058 109 601 P	SKODA	33413 SKODA 64 (→ 1062), ... , 87 (→ 1072)
058 109 601 P	VOLKSWAGEN	33413 VOLKSWAGEN 237 (→ 1216), ... , 302 (→ 1245)
058 109 611 E	SKODA	33394 SKODA 66 (→ 1063), ... , 71 (→ 1065)
058 109 611 E	VOLKSWAGEN	33394 VOLKSWAGEN 239 (→ 1217), ... , 251 (→ 1221)
058 109 611 M	VOLKSWAGEN	331107 VOLKSWAGEN 237 (→ 1216), ... , 302 (→ 1245)
058109601C	SKODA	33413 SKODA 64 (→ 1062), ... , 87 (→ 1072)
058923	ROVER	81-88003 ROVER 8 (→ 1023)
059 106 021 CK	VOLKSWAGEN	50 006 346 VOLKSWAGEN 124 (→ 1169)
059 109 009 AJ	VOLKSWAGEN	50 007 008 VOLKSWAGEN 348 (→ 1264), ... , 352 (→ 1266)
059 109 009 AM	VOLKSWAGEN	50 007 003 VOLKSWAGEN 350 (→ 1265)
059 109 009 BH	VOLKSWAGEN	50 006 344 VOLKSWAGEN 124 (→ 1169)
059 109 009 BJ	VOLKSWAGEN	50 006 345 VOLKSWAGEN 124 (→ 1169)
059 109 009 BK	VOLKSWAGEN	50 007 004 VOLKSWAGEN 348 (→ 1264), ... , 356 (→ 1267)
059 109 009 BL	VOLKSWAGEN	50 007 008 VOLKSWAGEN 348 (→ 1264), ... , 352 (→ 1266)
059 109 009 BP	VOLKSWAGEN	50 007 003 VOLKSWAGEN 350 (→ 1265)
059 109 009 DC	VOLKSWAGEN	50 007 003 VOLKSWAGEN 350 (→ 1265)
059 109 021 AS	VOLKSWAGEN	50 006 347 VOLKSWAGEN 124 (→ 1169)
059 109 021 BA	VOLKSWAGEN	50 006 346 VOLKSWAGEN 124 (→ 1169)
059 109 021 BH	VOLKSWAGEN	50 007 006 VOLKSWAGEN 348 (→ 1264), 349 (→ 1264)
059 109 021 BL	VOLKSWAGEN	50 007 006 VOLKSWAGEN 348 (→ 1264), 349 (→ 1264)
059 109 021 BP	VOLKSWAGEN	50 006 300 VOLKSWAGEN 122 (→ 1168), 123 (→ 1168)
059 109 021 BQ	VOLKSWAGEN	50 006 301 VOLKSWAGEN 122 (→ 1168), 123 (→ 1168)
059 109 021 BT	VOLKSWAGEN	50 007 003 VOLKSWAGEN 350 (→ 1265)
059 109 021 CB	VOLKSWAGEN	50 007 003 VOLKSWAGEN 350 (→ 1265)
059 109 021 CL	VOLKSWAGEN	50 006 347 VOLKSWAGEN 124 (→ 1169)
059 109 021 CR	VOLKSWAGEN	50 006 346 VOLKSWAGEN 124 (→ 1169)
059 109 021 CS	VOLKSWAGEN	50 006 347 VOLKSWAGEN 124 (→ 1169)

# ALPHANUMERICAL LIST

Reference	Item No.	Pos (→  )
059 109 021 DM VOLKSWAGEN	50 007 003	VOLKSWAGEN 350 (→ 1265)
059 109 021 DN VOLKSWAGEN	50 007 015	VOLKSWAGEN 351 (→ 1265), ... , 356 (→ 1267)
059 109 021 DS VOLKSWAGEN	50 007 002	VOLKSWAGEN 350 (→ 1265)
059 109 021 EE VOLKSWAGEN	50 007 006	VOLKSWAGEN 348 (→ 1264), 349 (→ 1264)
059 109 021 K VOLKSWAGEN	50 006 300	VOLKSWAGEN 122 (→ 1168), 123 (→ 1168)
059 109 021 L VOLKSWAGEN	50 006 301	VOLKSWAGEN 122 (→ 1168), 123 (→ 1168)
059 109 021 P VOLKSWAGEN	50 006 301	VOLKSWAGEN 122 (→ 1168), 123 (→ 1168)
059 109 021 Q VOLKSWAGEN	50 006 300	VOLKSWAGEN 122 (→ 1168), 123 (→ 1168)
059 109 022 AF VOLKSWAGEN	50 006 344	VOLKSWAGEN 124 (→ 1169)
059 109 022 AG VOLKSWAGEN	50 006 345	VOLKSWAGEN 124 (→ 1169)
059 109 022 BC VOLKSWAGEN	50 006 303	VOLKSWAGEN 122 (→ 1168), 123 (→ 1168)
059 109 022 BD VOLKSWAGEN	50 006 302	VOLKSWAGEN 122 (→ 1168), 123 (→ 1168)
059 109 022 BE VOLKSWAGEN	50 007 005	VOLKSWAGEN 348 (→ 1264), ... , 356 (→ 1267)
059 109 022 BQ VOLKSWAGEN	50 006 344	VOLKSWAGEN 124 (→ 1169)
059 109 022 BR VOLKSWAGEN	50 006 345	VOLKSWAGEN 124 (→ 1169)
059 109 022 K VOLKSWAGEN	50 006 303	VOLKSWAGEN 122 (→ 1168), 123 (→ 1168)
059 109 022 L VOLKSWAGEN	50 006 302	VOLKSWAGEN 122 (→ 1168), 123 (→ 1168)
059 109 022 P VOLKSWAGEN	50 006 302	VOLKSWAGEN 122 (→ 1168), 123 (→ 1168)
059 109 022 Q VOLKSWAGEN	50 006 303	VOLKSWAGEN 122 (→ 1168), 123 (→ 1168)
059 109 417 A VOLKSWAGEN	50 006 171	VOLKSWAGEN 181 (→ 1194), ... , 360 (→ 1269)
059 109 417 B VOLKSWAGEN	50 006 171	VOLKSWAGEN 181 (→ 1194), ... , 360 (→ 1269)
059 109 417 C VOLKSWAGEN	50 006 171	VOLKSWAGEN 181 (→ 1194), ... , 360 (→ 1269)
059 109 417 F VOLKSWAGEN	50 006 171	VOLKSWAGEN 181 (→ 1194), ... , 360 (→ 1269)
059 109 417 G VOLKSWAGEN	50 006 171	VOLKSWAGEN 181 (→ 1194), ... , 360 (→ 1269)
059 109 444 VOLKSWAGEN	50 006 410	VOLKSWAGEN 122 (→ 1168), 123 (→ 1168)
059 109 521 B VOLKSWAGEN	50 006 411	VOLKSWAGEN 122 (→ 1168), 123 (→ 1168)
059 109 521 C VOLKSWAGEN	50 006 411	VOLKSWAGEN 122 (→ 1168), 123 (→ 1168)
059 109 521 E VOLKSWAGEN	50 006 411	VOLKSWAGEN 122 (→ 1168), 123 (→ 1168)
059 109 521 G VOLKSWAGEN	50 006 420	VOLKSWAGEN 124 (→ 1169), ... , 349 (→ 1264)
059 109 601 B VOLKSWAGEN	331055	VOLKSWAGEN 122 (→ 1167), 123 (→ 1168)
059 109 601 C VOLKSWAGEN	331055	VOLKSWAGEN 122 (→ 1167), 123 (→ 1168)
059 109 601G VOLKSWAGEN	331133	VOLKSWAGEN 348 (→ 1263), ... , 361 (→ 1269)
059 109 611 B VOLKSWAGEN	331056	VOLKSWAGEN 122 (→ 1167), 123 (→ 1168)
059 109 611H VOLKSWAGEN	331134	VOLKSWAGEN 348 (→ 1263), ... , 361 (→ 1269)
059 109 611K VOLKSWAGEN	331134	VOLKSWAGEN 348 (→ 1263), ... , 361 (→ 1269)
059 109 611M VOLKSWAGEN	331134	VOLKSWAGEN 348 (→ 1263), ... , 361 (→ 1269)
059 109 611Q VOLKSWAGEN	331134	VOLKSWAGEN 348 (→ 1263), ... , 361 (→ 1269)
059109417J VOLKSWAGEN	50 006 171	VOLKSWAGEN 181 (→ 1194), ... , 360 (→ 1269)
06-0256 VOLVO	92-47011	VOLVO 102 (→ 1370), ... , 112 (→ 1377)
06-0258 VOLVO	92-47013	VOLVO 103 (→ 1371), ... , 111 (→ 1377)
06-0405 VOLVO	92-47012	VOLVO 102 (→ 1370), ... , 112 (→ 1377)
06-0461 VOLVO	92-47028	VOLVO 150 (→ 1401), ... , 168 (→ 1412)
062 109 601 VOLKSWAGEN	331113	VOLKSWAGEN 393 (→ 1278)
062 109 611A VOLKSWAGEN	331112	VOLKSWAGEN 393 (→ 1278)
068 103 351 D VOLKSWAGEN	50 003 358	VOLKSWAGEN 99 (→ 1159), ... , 113 (→ 1165)
068 103 351 E VOLKSWAGEN	50 003 358	VOLKSWAGEN 99 (→ 1159), ... , 113 (→ 1165)
068 103 351 G VOLKSWAGEN	50 003 358	VOLKSWAGEN 99 (→ 1159), ... , 113 (→ 1165)
068 103 351 K VOLKSWAGEN	50 003 358	VOLKSWAGEN 99 (→ 1159), ... , 113 (→ 1165)
068 109 101 L VOLKSWAGEN	50 006 214	VOLKSWAGEN 104 (→ 1161), ... , 114 (→ 1165)
068 109 601 D VOLKSWAGEN	4906	VOLKSWAGEN 99 (→ 1159), ... , 113 (→ 1165)
068 109 601 L VOLKSWAGEN	39183	VOLKSWAGEN 102 (→ 1160), ... , 107 (→ 1163)
068 109 601 N VOLKSWAGEN	331103	VOLKSWAGEN 99 (→ 1159), ... , 114 (→ 1165)
068 109 611 L VOLKSWAGEN	331102	VOLKSWAGEN 99 (→ 1159), ... , 115 (→ 1166)
069 109 101P VOLKSWAGEN	50 006 216	VOLKSWAGEN 136 (→ 1173), 154 (→ 1181)
069 109 601 D VOLKSWAGEN	33044	VOLKSWAGEN 100 (→ 1159), 133 (→ 1171)
069 109 601 F VOLKSWAGEN	39123	VOLKSWAGEN 48 (→ 1137), ... , 155 (→ 1181)
069 109 601 H VOLKSWAGEN	39143	VOLKSWAGEN 100 (→ 1159), ... , 141 (→ 1176)
06A 109 601E VOLKSWAGEN	33403	VOLKSWAGEN 221 (→ 1209), ... , 346 (→ 1263)
06B 109 101 G VOLKSWAGEN	50 006 309	VOLKSWAGEN 252 (→ 1222), 253 (→ 1223)
06B 109 101 Q VOLKSWAGEN	50 006 309	VOLKSWAGEN 252 (→ 1222), 253 (→ 1223)
06B 109 417 C VOLKSWAGEN	50 006 147	VOLKSWAGEN 252 (→ 1222), ... , 257 (→ 1224)
06B 109 601B VOLKSWAGEN	331057	VOLKSWAGEN 189 (→ 1197), ... , 257 (→ 1224)
06B 109 601D VOLKSWAGEN	331057	VOLKSWAGEN 189 (→ 1197), ... , 257 (→ 1224)
06B 109 601H VOLKSWAGEN	331057	VOLKSWAGEN 189 (→ 1197), ... , 257 (→ 1224)
06B 109 611 C VOLKSWAGEN	331058	VOLKSWAGEN 189 (→ 1197), ... , 257 (→ 1224)



# ALPHANUMERICAL LIST

Reference	Item No.	Pos (→  )		
06B 109 611 D	VOLKSWAGEN	331107	VOLKSWAGEN	237 (→ 1216), ... , 302 (→ 1245)
06B 109 611B	VOLKSWAGEN	331058	VOLKSWAGEN	189 (→ 1197), ... , 257 (→ 1224)
06D 109 101 AL	VOLKSWAGEN	50 007 588	VOLKSWAGEN	308 (→ 1248)
06D 109 101 AP	VOLKSWAGEN	50 007 588	VOLKSWAGEN	308 (→ 1248)
06D 109 102 AK	VOLKSWAGEN	50 007 589	VOLKSWAGEN	308 (→ 1248)
06D 109 601K	VOLKSWAGEN	331116	VOLKSWAGEN	307 (→ 1248), ... , 375 (→ 1274)
06D 109 601M	VOLKSWAGEN	331125	VOLKSWAGEN	309 (→ 1249), ... , 343 (→ 1262)
06D 109 611 P	VOLKSWAGEN	331126	VOLKSWAGEN	309 (→ 1249), ... , 374 (→ 1274)
06D 109 611H	VOLKSWAGEN	331126	VOLKSWAGEN	309 (→ 1249), ... , 374 (→ 1274)
06D 109 611K	VOLKSWAGEN	331117	VOLKSWAGEN	307 (→ 1248), ... , 341 (→ 1262)
06D 109 611L	VOLKSWAGEN	331117	VOLKSWAGEN	307 (→ 1248), ... , 341 (→ 1262)
06E 109 417	VOLKSWAGEN	50 006 148	VOLKSWAGEN	310 (→ 1249), ... , 319 (→ 1253)
06E 109 417 E	VOLKSWAGEN	50 006 148	VOLKSWAGEN	310 (→ 1249), ... , 319 (→ 1253)
06E 109 417 F	VOLKSWAGEN	50 006 149	VOLKSWAGEN	307 (→ 1248), ... , 314 (→ 1251)
06E 109 601E	VOLKSWAGEN	331116	VOLKSWAGEN	307 (→ 1248), ... , 375 (→ 1274)
06E 109 601F	VOLKSWAGEN	331116	VOLKSWAGEN	307 (→ 1248), ... , 375 (→ 1274)
06E 109 601Q	VOLKSWAGEN	331138	VOLKSWAGEN	311 (→ 1250), 312 (→ 1250)
06E 109 611D	VOLKSWAGEN	331117	VOLKSWAGEN	307 (→ 1248), ... , 341 (→ 1262)
06E 109 611K	VOLKSWAGEN	331160	VOLKSWAGEN	323 (→ 1255), ... , 375 (→ 1274)
06E109417AA	VOLKSWAGEN	50 007 657	VOLKSWAGEN	323 (→ 1255), ... , 371 (→ 1273)
06E109417N	VOLKSWAGEN	50 007 657	VOLKSWAGEN	323 (→ 1255), ... , 371 (→ 1273)
06F 109 101 B	VOLKSWAGEN	50 007 586	VOLKSWAGEN	309 (→ 1249)
06F 109 101J	VOLKSWAGEN	50 007 586	VOLKSWAGEN	309 (→ 1249)
06F 109 102 B	VOLKSWAGEN	50 007 587	VOLKSWAGEN	309 (→ 1249)
06H 109 022 AH	SKODA	50 007 712	SKODA	90 (→ 1074)
06H 109 022 AH	VOLKSWAGEN	50 007 712	VOLKSWAGEN	313 (→ 1251)
06H 109 022 BC	SKODA	50 007 712	SKODA	90 (→ 1074)
06H 109 022 BC	VOLKSWAGEN	50 007 712	VOLKSWAGEN	313 (→ 1251)
06H103144J	VOLKSWAGEN	50 007 669	VOLKSWAGEN	322 (→ 1254)
06H103144K	VOLKSWAGEN	50 007 669	VOLKSWAGEN	322 (→ 1254)
06H109021J	VOLKSWAGEN	50 007 634	VOLKSWAGEN	315 (→ 1251), ... , 319 (→ 1253)
06H109021K	SKODA	50 007 673	SKODA	90 (→ 1074)
06H109021K	VOLKSWAGEN	50 007 673	VOLKSWAGEN	310 (→ 1249), ... , 322 (→ 1254)
06H109022BA	VOLKSWAGEN	50 007 635	VOLKSWAGEN	315 (→ 1251), ... , 319 (→ 1253)
06J 106 601H	VOLKSWAGEN	331125	VOLKSWAGEN	309 (→ 1249), ... , 343 (→ 1262)
06J 109 611D	VOLKSWAGEN	331126	VOLKSWAGEN	309 (→ 1249), ... , 374 (→ 1274)
06K 109 601	VOLKSWAGEN	331162	VOLKSWAGEN	323 (→ 1255), ... , 373 (→ 1273)
06K 109 611	VOLKSWAGEN	331117	VOLKSWAGEN	307 (→ 1248), ... , 341 (→ 1262)
06K 109 611A	VOLKSWAGEN	331160	VOLKSWAGEN	323 (→ 1255), ... , 375 (→ 1274)
06K 109 611E	VOLKSWAGEN	331160	VOLKSWAGEN	323 (→ 1255), ... , 375 (→ 1274)
06L 109 601	VOLKSWAGEN	331162	VOLKSWAGEN	323 (→ 1255), ... , 373 (→ 1273)
06L103144F	VOLKSWAGEN	50 007 670	VOLKSWAGEN	325 (→ 1256), ... , 342 (→ 1262)
06L103144H	VOLKSWAGEN	50 007 670	VOLKSWAGEN	325 (→ 1256), ... , 342 (→ 1262)
07 10 939 000	RENAULT	81-5115	RENAULT	1 (→ 976), ... , 17 (→ 982)
07 10 942 500	RENAULT	81-5117	RENAULT	29 (→ 987), ... , 57 (→ 998)
070 109 101M	VOLKSWAGEN	50 007 577	VOLKSWAGEN	265 (→ 1228), 268 (→ 1229)
070 109 101P	VOLKSWAGEN	50 007 577	VOLKSWAGEN	265 (→ 1228), 268 (→ 1229)
070 109 101Q	VOLKSWAGEN	50 006 110	VOLKSWAGEN	266 (→ 1228)
073 109 601 D	VOLKSWAGEN	33046	VOLKSWAGEN	29 (→ 1132), ... , 94 (→ 1158)
074 103 265 EX	VOLKSWAGEN	50 003 415	VOLKSWAGEN	259 (→ 1226)
074 103 351 A	VOLKSWAGEN	50 003 101	VOLKSWAGEN	136 (→ 1173)
074 103 351 C	VOLKSWAGEN	50 003 115	VOLKSWAGEN	259 (→ 1226)
074 103 351 D	VOLKSWAGEN	50 003 113	VOLKSWAGEN	136 (→ 1173), 154 (→ 1181)
074 109 101 A	VOLKSWAGEN	50 006 215	VOLKSWAGEN	136 (→ 1173)
074 109 101 B	VOLKSWAGEN	50 006 216	VOLKSWAGEN	136 (→ 1173), 154 (→ 1181)
074 109 101 E	VOLKSWAGEN	50 006 283	VOLKSWAGEN	259 (→ 1226), ... , 281 (→ 1237)
074 109 101J	VOLKSWAGEN	50 006 283	VOLKSWAGEN	259 (→ 1226), ... , 281 (→ 1237)
074 109 309	VOLKSWAGEN	50 006 460	VOLKSWAGEN	29 (→ 1132), ... , 300 (→ 1245)
074 109 611	VOLKSWAGEN	33049	VOLKSWAGEN	48 (→ 1137), ... , 155 (→ 1181)
075 109 101 C	VOLKSWAGEN	50 006 218	VOLKSWAGEN	100 (→ 1160), ... , 115 (→ 1166)
075 109 101 F	VOLKSWAGEN	50 006 218	VOLKSWAGEN	100 (→ 1160), ... , 115 (→ 1166)
078 109 601A	VOLKSWAGEN	33403	VOLKSWAGEN	221 (→ 1209), ... , 346 (→ 1263)
078 109 601B	VOLKSWAGEN	33403	VOLKSWAGEN	221 (→ 1209), ... , 346 (→ 1263)
078 109 601E	VOLKSWAGEN	33403	VOLKSWAGEN	221 (→ 1209), ... , 346 (→ 1263)
078 109 601F	VOLKSWAGEN	33403	VOLKSWAGEN	221 (→ 1209), ... , 346 (→ 1263)

Reference		Item No.		Pos (→  )
078 109 611C	VOLKSWAGEN	33416	VOLKSWAGEN	221 (→ 1209), ... , 346 (→ 1263)
078109601B	SKODA	33403	SKODA	65 (→ 1062), ... , 86 (→ 1072)
079 109 601B	VOLKSWAGEN	331125	VOLKSWAGEN	309 (→ 1249), ... , 343 (→ 1262)
079 109 611D	VOLKSWAGEN	331160	VOLKSWAGEN	323 (→ 1255), ... , 375 (→ 1274)
07Z 109 101E	VOLKSWAGEN	50 006 399	VOLKSWAGEN	262 (→ 1227)
07Z 109 101F	VOLKSWAGEN	50 006 106	VOLKSWAGEN	262 (→ 1227)
07Z 109 101J	VOLKSWAGEN	50 006 109	VOLKSWAGEN	261 (→ 1227)
07Z 109 101K	VOLKSWAGEN	50 006 107	VOLKSWAGEN	261 (→ 1227)
08 54 895 300	RENAULT	MK-7H2	RENAULT	1 (→ 976), ... , 17 (→ 982)
1 639 187	FORD	50 006 460	FORD	44 (→ 306), ... , 64 (→ 311)
1 649 127	FORD	50 006 460	FORD	44 (→ 306), ... , 64 (→ 311)
1 669 765	FORD	50 006 460	FORD	44 (→ 306), ... , 64 (→ 311)
1 901 963	FIAT	50 004 282	FIAT	119 (→ 250), ... , 133 (→ 254)
1 902 205	FIAT	50 004 282	FIAT	119 (→ 250), ... , 133 (→ 254)
1003734	FORD	50 007 597	FORD	28 (→ 301), ... , 57 (→ 310)
1005252	FORD	81-3310	FORD	44 (→ 306)
1007308	FORD	50 007 597	FORD	28 (→ 301), ... , 57 (→ 310)
1012773	FORD	105-35529	FORD	69 (→ 312), 71 (→ 313)
1023591	FORD	105-35514	FORD	27 (→ 301), ... , 54 (→ 309)
1033899	FORD	105-35552	FORD	57 (→ 310), ... , 85 (→ 317)
1037330	FORD	50 007 597	FORD	28 (→ 301), ... , 57 (→ 310)
1037331	FORD	50 007 597	FORD	28 (→ 301), ... , 57 (→ 310)
1041838	FORD	105-35551	FORD	57 (→ 310), ... , 85 (→ 317)
1043175	FORD	50 007 597	FORD	28 (→ 301), ... , 57 (→ 310)
1051773	FORD	105-35541	FORD	31 (→ 302)
1053843	FORD	181021	FORD	59 (→ 310), 83 (→ 316)
1053845	FORD	181012	FORD	59 (→ 310), 82 (→ 316)
1066045	FORD	181021	FORD	59 (→ 310), 83 (→ 316)
1069529	FORD	181008	FORD	40 (→ 304)
1072048	FORD	181009	FORD	40 (→ 304)
1078426	FORD	50 007 029	FORD	73 (→ 314)
1078429	FORD	18375	FORD	69 (→ 312), ... , 72 (→ 314)
1078433	FORD	18374	FORD	70 (→ 313), 72 (→ 314)
1096250	FORD	181016	FORD	121 (→ 334), ... , 127 (→ 338)
1099936	FORD	50 007 609	FORD	121 (→ 334), 124 (→ 336)
11 12 1 250 268	BMW	81-1150	BMW	29 (→ 173)
11 12 1 255 295	BMW	81-1151	BMW	29 (→ 173)
11 12 1 259 934	BMW	81-1153	BMW	29 (→ 173), ... , 96 (→ 195)
11 12 1 259 935	BMW	81-1154	BMW	29 (→ 173), ... , 96 (→ 195)
11 12 1 263 642	BMW	81-1162	BMW	33 (→ 174), ... , 92 (→ 194)
11 12 1 266 760	BMW	81-1163	BMW	33 (→ 174), ... , 92 (→ 194)
11 12 1 266 761	BMW	81-1164	BMW	33 (→ 174), ... , 92 (→ 194)
11 12 1 267 676	BMW	81-1159	BMW	8 (→ 166), ... , 50 (→ 180)
11 12 1 267 677	BMW	81-1160	BMW	8 (→ 166), ... , 50 (→ 180)
11 12 1 267 678	BMW	81-1161	BMW	8 (→ 166), ... , 50 (→ 180)
11 12 1 280 523	BMW	81-1158	BMW	8 (→ 166), ... , 50 (→ 180)
11 12 1 335 568	BMW	81-1156	BMW	3 (→ 165), 28 (→ 172)
11 12 1 335 569	BMW	81-1157	BMW	3 (→ 165), 28 (→ 172)
11 12 1 338 061	BMW	81-1156	BMW	3 (→ 165), 28 (→ 172)
11 12 1 338 062	BMW	81-1157	BMW	3 (→ 165), 28 (→ 172)
11 12 1 338 435	BMW	81-1156	BMW	3 (→ 165), 28 (→ 172)
11 12 1 338 436	BMW	81-1157	BMW	3 (→ 165), 28 (→ 172)
11 12 1 338 708	BMW	81-11109	BMW	29 (→ 173), ... , 96 (→ 195)
11 12 1 338 709	BMW	81-1156	BMW	3 (→ 165), 28 (→ 172)
11 12 1 338 710	BMW	81-1157	BMW	3 (→ 165), 28 (→ 172)
11 12 1 461 561	BMW	81-11106	BMW	1 (→ 165)
11 12 1 715 373	BMW	81-11101	BMW	9 (→ 166), ... , 76 (→ 190)
11 12 1 715 373	BMW	81-11110	BMW	9 (→ 166), ... , 76 (→ 190)
11 12 1 735 534	BMW	81-11112	BMW	9 (→ 166), ... , 90 (→ 193)
11 12 2 244 464	BMW	81-11114	BMW	15 (→ 168), ... , 21 (→ 170)
11 12 2 247 056	BMW	50 006 132	BMW	16 (→ 169), ... , 68 (→ 187)
11 12 7 797 711	BMW	111216	BMW	61 (→ 185), ... , 65 (→ 186)
11 31 1 287 606	BMW	50 006 234	BMW	78 (→ 190), 86 (→ 192)
11 31 1 709 580	BMW	50 006 235	BMW	35 (→ 174), 36 (→ 175)
11 31 1 716 138	BMW	50 006 239	BMW	50 (→ 180)

# ALPHANUMERICAL LIST

Reference	Item No.	Pos (→  )
11 31 1 716 139 BMW	50 006 241 BMW	12 (→ 168)
11 31 1 739 176 BMW	50 006 327 BMW	32 (→ 173), ... , 58 (→ 183)
11 31 7 500 935 BMW	50 007 639 BMW	43 (→ 178), 44 (→ 178)
11 31 7 500 938 BMW	50 007 684 BMW	43 (→ 178)
11 31 7 507 994 BMW	50 007 684 BMW	43 (→ 178)
11 31 7 791 579 BMW	50 007 682 BMW	60 (→ 184)
11 31 7 791 580 BMW	50 007 683 BMW	60 (→ 184)
11 31 7 797 512 BMW	50 007 786 BMW	61 (→ 185)
11 31 7 797 513 BMW	50 007 785 BMW	61 (→ 185)
11 31 8 509 118 BMW	50 007 786 BMW	61 (→ 185)
11 31 8 509 119 BMW	50 007 785 BMW	61 (→ 185)
11 31 8 575 435 BMW	50 007 786 BMW	61 (→ 185)
11 31 8 575 436 BMW	50 007 785 BMW	61 (→ 185)
11 32 1 739 299 BMW	50 006 475 BMW	9 (→ 167), ... , 53 (→ 181)
11 32 1 748 880 BMW	50 006 409 BMW	10 (→ 167), ... , 94 (→ 194)
11 32 1 748 881 BMW	50 006 409 BMW	10 (→ 167), ... , 94 (→ 194)
11 32 1 748 882 BMW	50 006 409 BMW	10 (→ 167), ... , 94 (→ 194)
11 32 1 748 884 BMW	50 006 409 BMW	10 (→ 167), ... , 94 (→ 194)
11 33 1 247 054 BMW	50 006 476 BMW	32 (→ 174), ... , 70 (→ 188)
11 33 1 433 672 BMW	50 006 476 BMW	32 (→ 174), ... , 70 (→ 188)
11 33 1 707 712 BMW	50 006 493 BMW	42 (→ 177), ... , 91 (→ 194)
11 33 1 712 010 BMW	50 006 476 BMW	32 (→ 174), ... , 70 (→ 188)
11 33 1 714 604 BMW	50 006 476 BMW	32 (→ 174), ... , 70 (→ 188)
11 33 1 715 458 BMW	50 006 476 BMW	32 (→ 174), ... , 70 (→ 188)
11 33 1 721 698 BMW	50 006 476 BMW	32 (→ 174), ... , 70 (→ 188)
11 33 2 247 722 BMW	50 006 414 BMW	16 (→ 169), ... , 68 (→ 187)
11 33 2 248 878 BMW	50 006 132 BMW	16 (→ 169), ... , 68 (→ 187)
11 33 2 249 817 BMW	50 006 414 BMW	16 (→ 169), ... , 68 (→ 187)
11 33 7 512 116 BMW	50 006 493 BMW	42 (→ 177), ... , 91 (→ 194)
11 33 7 542 421 BMW	50 006 128 BMW	23 (→ 171), 48 (→ 180)
11 33 7 546 466 BMW	50 006 492 BMW	22 (→ 171), ... , 73 (→ 189)
11 33 7 548 690 BMW	50 006 492 BMW	22 (→ 171), ... , 73 (→ 189)
11 33 7 549 632 BMW	50 006 135 BMW	5 (→ 165)
11 33 7 559 797 BMW	50 006 129 BMW	22 (→ 171), ... , 73 (→ 189)
11 33 7 797 710 BMW	50 007 810 BMW	6 (→ 166), ... , 64 (→ 186)
11 33 7 812 893 BMW	50 006 133 BMW	61 (→ 185), ... , 67 (→ 187)
11 33 8 576 634 BMW	50 007 810 BMW	6 (→ 166), ... , 64 (→ 186)
11 34 0 150 844 BMW	MK-6H BMW	9 (→ 166), ... , 91 (→ 194)
11 34 1 250 129 BMW	1125 BMW	75 (→ 189), ... , 92 (→ 194)
11 34 1 250 234 BMW	1135 BMW	4 (→ 165), ... , 95 (→ 194)
11 34 1 251 063 BMW	1123 BMW	77 (→ 190)
11 34 1 251 498 BMW	1198 BMW	33 (→ 174), 84 (→ 192)
11 34 1 251 879 BMW	1195 BMW	33 (→ 174), 84 (→ 192)
11 34 1 254 625 BMW	1132 BMW	77 (→ 190)
11 34 1 257 587 BMW	1142 BMW	75 (→ 189), ... , 92 (→ 194)
11 34 1 257 837 BMW	111203 BMW	85 (→ 192), 96 (→ 194)
11 34 1 261 751 BMW	1154 BMW	96 (→ 194)
11 34 1 265 453 BMW	1155 BMW	8 (→ 166), ... , 34 (→ 174)
11 34 1 267 687 BMW	1155 BMW	8 (→ 166), ... , 34 (→ 174)
11 34 1 267 721 BMW	1155 BMW	8 (→ 166), ... , 34 (→ 174)
11 34 1 267 722 BMW	1156 BMW	8 (→ 166), ... , 34 (→ 174)
11 34 1 273 592 BMW	1142 BMW	75 (→ 189), ... , 92 (→ 194)
11 34 1 275 965 BMW	1184 BMW	14 (→ 168), 17 (→ 169)
11 34 1 280 643 BMW	1156 BMW	8 (→ 166), ... , 34 (→ 174)
11 34 1 287 814 BMW	11129 BMW	50 (→ 180)
11 34 1 307 136 BMW	MK-7H BMW	8 (→ 166), ... , 93 (→ 194)
11 34 1 309 343 BMW	11211 BMW	93 (→ 194)
11 34 1 337 453 BMW	111201 BMW	4 (→ 165), 29 (→ 172)
11 34 1 338 285 BMW	111202 BMW	95 (→ 194)
11 34 1 433 699 BMW	111031 BMW	79 (→ 191), ... , 90 (→ 193)
11 34 1 433 892 BMW	11673 BMW	32 (→ 173), ... , 76 (→ 190)
11 34 1 433 893 BMW	11672 BMW	32 (→ 173), ... , 76 (→ 190)
11 34 1 435 461 BMW	111208 BMW	43 (→ 178), ... , 91 (→ 193)
11 34 1 435 482 BMW	111031 BMW	79 (→ 191), ... , 90 (→ 193)
11 34 1 438 284 BMW	11960 BMW	38 (→ 176), ... , 70 (→ 188)



Reference	Item No.	Pos (→  )
11 34 1 438 381 BMW	11613	BMW 9 (→ 166), ... , 13 (→ 168)
11 34 1 438 385 BMW	11960	BMW 38 (→ 176), ... , 70 (→ 188)
11 34 1 438 449 BMW	11613	BMW 9 (→ 166), ... , 13 (→ 168)
11 34 1 438 451 BMW	11960	BMW 38 (→ 176), ... , 70 (→ 188)
11 34 1 440 304 BMW	111210	BMW 42 (→ 177), 45 (→ 178)
11 34 1 461 405 BMW	MK-6H	BMW 9 (→ 166), ... , 91 (→ 194)
11 34 1 705 560 BMW	11102	BMW 86 (→ 192)
11 34 1 707 519 BMW	111209	BMW 42 (→ 177), ... , 91 (→ 193)
11 34 1 708 895 BMW	11104	BMW 50 (→ 180)
11 34 1 708 896 BMW	11129	BMW 50 (→ 180)
11 34 1 709 941 BMW	11131	BMW 35 (→ 174), ... , 37 (→ 175)
11 34 1 710 975 BMW	MK-8H	BMW 4 (→ 165), ... , 96 (→ 195)
11 34 1 720 827 BMW	11104	BMW 50 (→ 180)
11 34 1 720 828 BMW	11129	BMW 50 (→ 180)
11 34 1 722 891 BMW	11360	BMW 51 (→ 180), 53 (→ 181)
11 34 1 722 892 BMW	11359	BMW 51 (→ 180), 53 (→ 181)
11 34 1 722 893 BMW	11360	BMW 51 (→ 180), 53 (→ 181)
11 34 1 722 896 BMW	11357	BMW 9 (→ 166), ... , 13 (→ 168)
11 34 1 722 897 BMW	11358	BMW 9 (→ 166), ... , 13 (→ 168)
11 34 1 722 908 BMW	11359	BMW 51 (→ 180), 53 (→ 181)
11 34 1 722 909 BMW	11360	BMW 51 (→ 180), 53 (→ 181)
11 34 1 722 910 BMW	11357	BMW 9 (→ 166), ... , 13 (→ 168)
11 34 1 722 911 BMW	11358	BMW 9 (→ 166), ... , 13 (→ 168)
11 34 1 726 903 BMW	11360	BMW 51 (→ 180), 53 (→ 181)
11 34 1 727 151 BMW	11360	BMW 51 (→ 180), 53 (→ 181)
11 34 1 727 352 BMW	111200	BMW 35 (→ 174), ... , 37 (→ 175)
11 34 1 727 358 BMW	11131	BMW 35 (→ 174), ... , 37 (→ 175)
11 34 1 731 640 BMW	11539	BMW 79 (→ 191), ... , 90 (→ 193)
11 34 1 736 549 BMW	11539	BMW 79 (→ 191), ... , 90 (→ 193)
11 34 1 738 214 BMW	11613	BMW 9 (→ 166), ... , 13 (→ 168)
11 34 1 738 215 BMW	11612	BMW 9 (→ 166), ... , 13 (→ 168)
11 34 1 738 218 BMW	11960	BMW 38 (→ 176), ... , 70 (→ 188)
11 34 1 738 219 BMW	11964	BMW 38 (→ 176), ... , 70 (→ 188)
11 34 1 738 220 BMW	11613	BMW 9 (→ 166), ... , 13 (→ 168)
11 34 1 738 221 BMW	11612	BMW 9 (→ 166), ... , 13 (→ 168)
11 34 1 739 114 BMW	11673	BMW 32 (→ 173), ... , 76 (→ 190)
11 34 1 739 658 BMW	11673	BMW 32 (→ 173), ... , 76 (→ 190)
11 34 1 739 665 BMW	11672	BMW 32 (→ 173), ... , 76 (→ 190)
11 34 1 739 820 BMW	11960	BMW 38 (→ 176), ... , 70 (→ 188)
11 34 1 739 821 BMW	11964	BMW 38 (→ 176), ... , 70 (→ 188)
11 34 1 739 822 BMW	11960	BMW 38 (→ 176), ... , 70 (→ 188)
11 34 1 739 823 BMW	11964	BMW 38 (→ 176), ... , 70 (→ 188)
11 34 2 242 621 BMW	1180	BMW 14 (→ 168), 17 (→ 169)
11 34 2 242 622 BMW	1184	BMW 14 (→ 168), 17 (→ 169)
11 34 2 242 623 BMW	1184	BMW 14 (→ 168), 17 (→ 169)
11 34 2 242 624 BMW	1180	BMW 14 (→ 168), 17 (→ 169)
11 34 2 244 814 BMW	11732	BMW 15 (→ 168), ... , 21 (→ 170)
11 34 2 247 077 BMW	111113	BMW 16 (→ 169), ... , 68 (→ 187)
11 34 4 457 287 BMW	111209	BMW 42 (→ 177), ... , 91 (→ 193)
11 34 7 502 173 BMW	11612	BMW 9 (→ 166), ... , 13 (→ 168)
11 34 7 502 351 BMW	11612	BMW 9 (→ 166), ... , 13 (→ 168)
11 34 7 503 737 BMW	111208	BMW 43 (→ 178), ... , 91 (→ 193)
11 34 7 503 738 BMW	111209	BMW 42 (→ 177), ... , 91 (→ 193)
11 34 7 529 839 BMW	111209	BMW 42 (→ 177), ... , 91 (→ 193)
11 34 7 539 915 BMW	111219	BMW 71 (→ 188)
11 34 7 539 919 BMW	111217	BMW 22 (→ 171)
11 34 7 541 555 BMW	111208	BMW 43 (→ 178), ... , 91 (→ 193)
11 34 7 547 187 BMW	539031	BMW 5 (→ 165)
11 34 7 548 280 BMW	111213	BMW 45 (→ 178), 48 (→ 180)
11 34 7 552 053 BMW	111212	BMW 23 (→ 171)
11 34 7 552 952 BMW	111800	BMW 73 (→ 189), 74 (→ 189)
11 34 7 552 953 BMW	111801	BMW 73 (→ 189), 74 (→ 189)
11 34 7 553 771 BMW	111219	BMW 71 (→ 188)
11 34 7 553 772 BMW	111220	BMW 71 (→ 188)
11 34 7 553 774 BMW	111218	BMW 22 (→ 171)

# ALPHANUMERICAL LIST

Reference	Item No.	Pos (→  )		
11 34 7 553 775	BMW	111222	BMW	47 (→ 179)
11 34 7 555 760	BMW	111211	BMW	23 (→ 171)
11 34 7 570 163	BMW	111229	BMW	80 (→ 191), 82 (→ 191)
11 34 7 570 164	BMW	111230	BMW	80 (→ 191), 82 (→ 191)
11 34 7 573 840	BMW	111214	BMW	45 (→ 178), ... , 48 (→ 180)
11 34 7 583 777	BMW	111223	BMW	46 (→ 179), ... , 57 (→ 183)
11 34 7 583 779	BMW	111223	BMW	46 (→ 179), ... , 57 (→ 183)
11 34 7 583 780	BMW	111225	BMW	46 (→ 179), ... , 57 (→ 183)
11 34 7 585 901	BMW	111226	BMW	5 (→ 165)
11 34 7 598 273	BMW	111225	BMW	46 (→ 179), ... , 57 (→ 183)
11 34 7 633 699	BMW	111234	BMW	25 (→ 172), ... , 31 (→ 173)
11 34 7 797 712	BMW	111215	BMW	61 (→ 185), ... , 65 (→ 186)
11 34 7 799 612	BMW	111221	BMW	68 (→ 187)
11 34 7 812 615	BMW	111215	BMW	61 (→ 185), ... , 65 (→ 186)
11 34 7 812 616	BMW	111228	BMW	6 (→ 165)
11 34 7 812 618	BMW	111227	BMW	6 (→ 165)
11 34 8 511 622	BMW	111215	BMW	61 (→ 185), ... , 65 (→ 186)
11 34 8 621 264	BMW	111233	BMW	25 (→ 172), ... , 31 (→ 173)
11 37 7 539 966	BMW	50 007 850	BMW	5 (→ 165), ... , 83 (→ 191)
1100013	FORD	50 007 608	FORD	121 (→ 334), 124 (→ 336)
1100669	FORD	50 006 304	FORD	46 (→ 307)
1100677	FORD	50 006 418	FORD	46 (→ 307), 47 (→ 307)
1101934	FORD	181008	FORD	40 (→ 304)
11039-EB30A	NISSAN	50 003 175	NISSAN	37 (→ 939), ... , 42 (→ 940)
11039-EC00A	NISSAN	50 003 175	NISSAN	37 (→ 939), ... , 42 (→ 940)
11040-EB300	NISSAN	50 003 175	NISSAN	37 (→ 939), ... , 42 (→ 940)
11040-EB30A	NISSAN	50 003 175	NISSAN	37 (→ 939), ... , 42 (→ 940)
11040-EC00A	NISSAN	50 003 175	NISSAN	37 (→ 939), ... , 42 (→ 940)
11040-EC00C	NISSAN	50 003 175	NISSAN	37 (→ 939), ... , 42 (→ 940)
11129092	VOLVO	81-47124	VOLVO	102 (→ 1370), ... , 135 (→ 1390)
1113187	FORD	181113	FORD	6 (→ 292), 7 (→ 293)
1113189	FORD	181107	FORD	32 (→ 302), ... , 42 (→ 305)
1113197	FORD	181014	FORD	70 (→ 313), ... , 74 (→ 315)
1120750	FORD	50 007 610	FORD	104 (→ 325), 105 (→ 325)
1120752	FORD	50 007 611	FORD	104 (→ 325), 105 (→ 325)
1121331	FORD	181018	FORD	90 (→ 319), ... , 128 (→ 339)
1121332	FORD	181019	FORD	90 (→ 319), ... , 128 (→ 339)
1121333	FORD	181018	FORD	90 (→ 319), ... , 128 (→ 339)
1122364	FORD	181106	FORD	40 (→ 304), 42 (→ 305)
1124377	FORD	181109	FORD	115 (→ 333)
1124378	FORD	181108	FORD	115 (→ 333)
1124514	FORD	181021	FORD	59 (→ 310), 83 (→ 316)
1124619	FORD	181109	FORD	115 (→ 333)
113 101 401	VOLKSWAGEN	81-3907	VOLKSWAGEN	117 (→ 1166), ... , 378 (→ 1275)
113 101 403 A	VOLKSWAGEN	81-3958	VOLKSWAGEN	118 (→ 1167), ... , 380 (→ 1275)
113 101 404	VOLKSWAGEN	81-3908	VOLKSWAGEN	117 (→ 1166), ... , 378 (→ 1275)
113 101 415	VOLKSWAGEN	81-3910	VOLKSWAGEN	117 (→ 1166), ... , 378 (→ 1275)
113 109 651 A	VOLKSWAGEN	MK-8H	VOLKSWAGEN	29 (→ 1132), ... , 398 (→ 1280)
1132466	FORD	181019	FORD	90 (→ 319), ... , 128 (→ 339)
1132467	FORD	181019	FORD	90 (→ 319), ... , 128 (→ 339)
11331709063	BMW	50 007 617	BMW	35 (→ 175), ... , 37 (→ 175)
11337549633	BMW	50 007 614	BMW	5 (→ 165)
1145932	FORD	181103	FORD	13 (→ 296), ... , 15 (→ 297)
1145933	FORD	181102	FORD	13 (→ 296), ... , 15 (→ 297)
1145959	FORD	50 006 172	FORD	13 (→ 297)
1146061	FORD	50 006 419	FORD	13 (→ 296)
1151997	FORD	181115	FORD	32 (→ 302)
1152190	FORD	181103	FORD	13 (→ 296), ... , 15 (→ 297)
1152191	FORD	181102	FORD	13 (→ 296), ... , 15 (→ 297)
1198044	FORD	181015	FORD	70 (→ 313), ... , 74 (→ 315)
1202362	FORD	181103	FORD	13 (→ 296), ... , 15 (→ 297)
1207533	FORD	181112	FORD	6 (→ 292), 7 (→ 293)
1211483	FORD	181110	FORD	75 (→ 315)
1213175	FORD	181108	FORD	115 (→ 333)
1214456	FORD	181019	FORD	90 (→ 319), ... , 128 (→ 339)

Reference		Item No.		Pos (→  )
1216915	FORD	181018	FORD	90 (→ 319), ... , 128 (→ 339)
1217148	FORD	181018	FORD	90 (→ 319), ... , 128 (→ 339)
1229882	FORD	539009	FORD	20 (→ 298), ... , 22 (→ 299)
1229883	FORD	539010	FORD	20 (→ 298), ... , 22 (→ 299)
1231272	FORD	50 006 485	FORD	22 (→ 299)
1231929	FORD	50 006 145	FORD	87 (→ 318), ... , 94 (→ 321)
1231930	FORD	181105	FORD	87 (→ 318), ... , 94 (→ 321)
1231931	FORD	181104	FORD	87 (→ 318), 88 (→ 318)
1254284	FORD	181016	FORD	121 (→ 334), ... , 127 (→ 338)
1255011	FORD	50 006 096	FORD	87 (→ 318), ... , 89 (→ 318)
1257613	VOLVO	81-3310	VOLVO	6 (→ 1338), ... , 23 (→ 1342)
1270391	VOLVO	81-47105	VOLVO	9 (→ 1339), ... , 48 (→ 1349)
1275353	VOLVO	50 007 605	VOLVO	16 (→ 1340), ... , 37 (→ 1346)
12G1111	ROVER	81-88004	ROVER	1 (→ 1023)
13 20 103 70R	RENAULT	539044	RENAULT	52 (→ 996), 53 (→ 996)
13 20 135 62R	RENAULT	539048	RENAULT	10 (→ 978), 11 (→ 979)
13 20 173 22R	RENAULT	539048	RENAULT	10 (→ 978), 11 (→ 979)
13 20 248 94R	RENAULT	539045	RENAULT	52 (→ 996), 53 (→ 996)
13 20 253 79R	RENAULT	539052	RENAULT	10 (→ 978), 11 (→ 979)
13 20 272 23R	RENAULT	539052	RENAULT	10 (→ 978), 11 (→ 979)
13 23 100 94R	RENAULT	50 007 816	RENAULT	9 (→ 978), ... , 12 (→ 980)
13 23 103 50R	RENAULT	50 007 818	RENAULT	9 (→ 978), ... , 12 (→ 980)
13 23 103 55R	RENAULT	50 007 819	RENAULT	9 (→ 978), ... , 12 (→ 980)
13 23 104 01R	RENAULT	50 007 820	RENAULT	9 (→ 978), ... , 12 (→ 980)
13 23 105 14R	RENAULT	50 007 821	RENAULT	9 (→ 978), ... , 12 (→ 980)
13 23 105 73R	RENAULT	50 007 822	RENAULT	9 (→ 978), ... , 12 (→ 980)
13 23 107 66R	RENAULT	50 007 823	RENAULT	9 (→ 978), ... , 12 (→ 980)
13 23 110 18R	RENAULT	50 007 814	RENAULT	9 (→ 978), ... , 12 (→ 980)
13 23 110 28R	RENAULT	50 007 824	RENAULT	9 (→ 978), ... , 12 (→ 980)
13 23 110 55R	RENAULT	50 007 815	RENAULT	9 (→ 978), ... , 12 (→ 980)
13 23 114 44R	RENAULT	50 007 825	RENAULT	9 (→ 978), ... , 12 (→ 980)
13 23 119 89R	RENAULT	50 007 826	RENAULT	9 (→ 978), ... , 12 (→ 980)
13 23 125 91R	RENAULT	50 007 827	RENAULT	9 (→ 978), ... , 12 (→ 980)
13 23 144 87R	RENAULT	50 007 828	RENAULT	9 (→ 978), ... , 12 (→ 980)
13 23 144 88R	RENAULT	50 007 830	RENAULT	9 (→ 978), ... , 12 (→ 980)
13 23 145 63R	RENAULT	50 007 831	RENAULT	9 (→ 978), ... , 12 (→ 980)
13 23 153 87R	RENAULT	50 007 845	RENAULT	9 (→ 978), ... , 12 (→ 980)
13 23 157 48R	RENAULT	50 007 832	RENAULT	9 (→ 978), ... , 12 (→ 980)
13 23 159 24R	RENAULT	50 007 833	RENAULT	9 (→ 978), ... , 12 (→ 980)
13 23 162 45R	RENAULT	50 007 834	RENAULT	9 (→ 978), ... , 12 (→ 980)
13 23 165 09R	RENAULT	50 007 835	RENAULT	9 (→ 978), ... , 12 (→ 980)
13 23 168 83R	RENAULT	50 007 836	RENAULT	9 (→ 978), ... , 12 (→ 980)
13 23 169 19R	RENAULT	50 007 838	RENAULT	9 (→ 978), ... , 12 (→ 980)
13 23 170 88R	RENAULT	50 007 839	RENAULT	9 (→ 978), ... , 12 (→ 980)
13 23 171 11R	RENAULT	50 007 840	RENAULT	9 (→ 978), ... , 12 (→ 980)
13 23 171 31R	RENAULT	50 007 841	RENAULT	9 (→ 978), ... , 12 (→ 980)
13 23 183 35R	RENAULT	50 007 846	RENAULT	9 (→ 978), ... , 12 (→ 980)
13 23 184 83R	RENAULT	50 007 842	RENAULT	9 (→ 978), ... , 12 (→ 980)
13 23 187 70R	RENAULT	50 007 847	RENAULT	9 (→ 978), ... , 12 (→ 980)
13 23 188 43R	RENAULT	50 007 843	RENAULT	9 (→ 978), ... , 12 (→ 980)
13 23 196 49R	RENAULT	50 007 844	RENAULT	9 (→ 978), ... , 12 (→ 980)
13001-00Q0T	NISSAN	50 007 076	NISSAN	6 (→ 931), ... , 9 (→ 933)
13001-AU600	NISSAN	50 007 802	NISSAN	39 (→ 939)
13020 VB100	NISSAN	50 006 330	NISSAN	31 (→ 937)
13020-4KV0A	NISSAN	50 007 703	NISSAN	39 (→ 939)
13020-4KV0C	NISSAN	50 007 704	NISSAN	39 (→ 939)
13020-5M306	NISSAN	50 007 803	NISSAN	39 (→ 939)
13020-AD202	NISSAN	50 007 803	NISSAN	39 (→ 939)
13020-AD212	NISSAN	50 007 802	NISSAN	39 (→ 939)
1313804	FORD	50 007 093	FORD	22 (→ 299)
1313804	FORD	50 007 573	FORD	22 (→ 299)
1313805	FORD	50 007 094	FORD	22 (→ 299)
1313805	FORD	50 007 574	FORD	22 (→ 299)
1317792	VOLVO	4730	VOLVO	64 (→ 1354)
1317792-8	VOLVO	4730	VOLVO	64 (→ 1354)

# ALPHANUMERICAL LIST

Reference	Item No.	Pos (→  )
13177928	VOLVO	4730 VOLVO 64 (→ 1354)
1317793	VOLVO	4729 VOLVO 64 (→ 1354)
1317793-6	VOLVO	4729 VOLVO 64 (→ 1354)
13177936	VOLVO	4729 VOLVO 64 (→ 1354)
1319249	FORD	50 006 433 FORD 22 (→ 299)
13201-00QAA	NISSAN	531031 NISSAN 13 (→ 933)
13201-00QAC	NISSAN	511013 NISSAN 17 (→ 934)
13201-00QAE	NISSAN	539011 NISSAN 19 (→ 935), 20 (→ 935)
13201-00QAJ	NISSAN	539028 NISSAN 2 (→ 929)
13201-00QAM	NISSAN	511013 NISSAN 17 (→ 934)
13201-00QAN	NISSAN	539018 NISSAN 6 (→ 931), ... , 8 (→ 932)
13201-00QOA	NISSAN	539024 NISSAN 24 (→ 936), ... , 32 (→ 937)
13201-2J201	NISSAN	701007 NISSAN 34 (→ 938)
13201-AD210	NISSAN	701030 NISSAN 35 (→ 938), ... , 43 (→ 940)
13201-AU300	NISSAN	701034 NISSAN 15 (→ 934)
13201-AW300	NISSAN	511013 NISSAN 17 (→ 934)
13201-BN300	NISSAN	701030 NISSAN 35 (→ 938), ... , 43 (→ 940)
13201-BN700	NISSAN	539018 NISSAN 6 (→ 931), ... , 8 (→ 932)
13201-EB300	NISSAN	701030 NISSAN 35 (→ 938), ... , 43 (→ 940)
13201-ED000	NISSAN	701032 NISSAN 12 (→ 933)
13201-ED00C	NISSAN	701032 NISSAN 12 (→ 933)
1320100QAD	NISSAN	539020 NISSAN 38 (→ 939), 41 (→ 940)
13202-00QAA	NISSAN	531032 NISSAN 13 (→ 933)
13202-00QAE	NISSAN	539014 NISSAN 19 (→ 935), 20 (→ 935)
13202-00QAK	NISSAN	539029 NISSAN 2 (→ 929)
13202-00QAN	NISSAN	511014 NISSAN 17 (→ 934)
13202-00QAP	NISSAN	539017 NISSAN 6 (→ 931), ... , 8 (→ 932)
13202-00QOA	NISSAN	539025 NISSAN 24 (→ 936), ... , 32 (→ 937)
13202-AD210	NISSAN	701031 NISSAN 35 (→ 938), ... , 43 (→ 940)
13202-AU300	NISSAN	701035 NISSAN 15 (→ 934)
13202-AW300	NISSAN	511014 NISSAN 17 (→ 934)
13202-BN300	NISSAN	701031 NISSAN 35 (→ 938), ... , 43 (→ 940)
13202-BN700	NISSAN	539017 NISSAN 6 (→ 931), ... , 8 (→ 932)
13202-EB300	NISSAN	701031 NISSAN 35 (→ 938), ... , 43 (→ 940)
13202-ED000	NISSAN	701033 NISSAN 12 (→ 933)
13202-ED00C	NISSAN	701033 NISSAN 12 (→ 933)
1320200QAD	NISSAN	539021 NISSAN 38 (→ 939), 41 (→ 940)
1320926	FORD	181115 FORD 32 (→ 302)
1320927	FORD	181106 FORD 40 (→ 304), 42 (→ 305)
1320928	FORD	181112 FORD 6 (→ 292), 7 (→ 293)
13212-53J60	NISSAN	81-70003 NISSAN 22 (→ 935), ... , 34 (→ 938)
13212-AD260	NISSAN	81-70008 NISSAN 36 (→ 938), ... , 40 (→ 940)
13212-D0110	NISSAN	81-70001 NISSAN 11 (→ 933), ... , 31 (→ 937)
13213-AD260	NISSAN	81-70009 NISSAN 36 (→ 938), ... , 40 (→ 940)
13231-00Q0A	NISSAN	50 007 814 NISSAN 3 (→ 929), ... , 5 (→ 931)
13231-00Q0B	NISSAN	50 007 815 NISSAN 3 (→ 929), ... , 5 (→ 931)
13231-00Q0C	NISSAN	50 007 816 NISSAN 3 (→ 929), ... , 5 (→ 931)
13231-00Q0D	NISSAN	50 007 818 NISSAN 3 (→ 929), ... , 5 (→ 931)
13231-00Q0E	NISSAN	50 007 819 NISSAN 3 (→ 929), ... , 5 (→ 931)
13231-00Q0F	NISSAN	50 007 820 NISSAN 3 (→ 929), ... , 5 (→ 931)
13231-00Q0G	NISSAN	50 007 821 NISSAN 3 (→ 929), ... , 5 (→ 931)
13231-00Q0H	NISSAN	50 007 822 NISSAN 3 (→ 929), ... , 5 (→ 931)
13231-00Q0J	NISSAN	50 007 823 NISSAN 3 (→ 929), ... , 5 (→ 931)
13231-00Q0K	NISSAN	50 007 824 NISSAN 3 (→ 929), ... , 5 (→ 931)
13231-00Q0L	NISSAN	50 007 825 NISSAN 3 (→ 929), ... , 5 (→ 931)
13231-00Q0M	NISSAN	50 007 826 NISSAN 3 (→ 929), ... , 5 (→ 931)
13231-00Q1A	NISSAN	50 007 827 NISSAN 3 (→ 929), ... , 5 (→ 931)
13231-00Q1B	NISSAN	50 007 828 NISSAN 3 (→ 929), ... , 5 (→ 931)
13231-00Q1C	NISSAN	50 007 830 NISSAN 3 (→ 929), ... , 5 (→ 931)
13231-00Q1D	NISSAN	50 007 831 NISSAN 3 (→ 929), ... , 5 (→ 931)
13231-00Q1E	NISSAN	50 007 832 NISSAN 3 (→ 929), ... , 5 (→ 931)
13231-00Q1F	NISSAN	50 007 833 NISSAN 3 (→ 929), ... , 5 (→ 931)
13231-00Q1G	NISSAN	50 007 834 NISSAN 3 (→ 929), ... , 5 (→ 931)
13231-00Q1H	NISSAN	50 007 835 NISSAN 3 (→ 929), ... , 5 (→ 931)
13231-00Q1J	NISSAN	50 007 836 NISSAN 3 (→ 929), ... , 5 (→ 931)

# ALPHANUMERICAL LIST

Reference		Item No.		Pos (→  )
13231-00Q1K	NISSAN	50 007 838	NISSAN	3 (→ 929), ... , 5 (→ 931)
13231-00Q1L	NISSAN	50 007 839	NISSAN	3 (→ 929), ... , 5 (→ 931)
13231-00Q1M	NISSAN	50 007 840	NISSAN	3 (→ 929), ... , 5 (→ 931)
13231-00Q2A	NISSAN	50 007 841	NISSAN	3 (→ 929), ... , 5 (→ 931)
13231-00Q2B	NISSAN	50 007 842	NISSAN	3 (→ 929), ... , 5 (→ 931)
13231-00Q2C	NISSAN	50 007 843	NISSAN	3 (→ 929), ... , 5 (→ 931)
13231-00Q2D	NISSAN	50 007 844	NISSAN	3 (→ 929), ... , 5 (→ 931)
13231-00Q2E	NISSAN	50 007 845	NISSAN	3 (→ 929), ... , 5 (→ 931)
13231-00Q2F	NISSAN	50 007 846	NISSAN	3 (→ 929), ... , 5 (→ 931)
13231-00Q2G	NISSAN	50 007 847	NISSAN	3 (→ 929), ... , 5 (→ 931)
13231-40L00	NISSAN	50 007 602	NISSAN	28 (→ 937), ... , 31 (→ 937)
13231-40L05	NISSAN	50 007 602	NISSAN	28 (→ 937), ... , 31 (→ 937)
13231-79S00	NISSAN	50 007 665	NISSAN	14 (→ 934), ... , 23 (→ 935)
13231-V7215	NISSAN	50 007 666	NISSAN	29 (→ 937)
1323400Q0A	NISSAN	50 006 432	NISSAN	24 (→ 936), ... , 32 (→ 938)
1324131	FORD	181109	FORD	115 (→ 333)
1324132	FORD	181108	FORD	115 (→ 333)
1324690	FORD	181111	FORD	75 (→ 315)
1324691	FORD	181110	FORD	75 (→ 315)
13257-00Q0A	NISSAN	50 007 711	NISSAN	18 (→ 935)
13257-00QAB	NISSAN	50 006 486	NISSAN	13 (→ 934), 19 (→ 935)
1328147	VOLVO	33044	VOLVO	6 (→ 1338), 7 (→ 1338)
1328147-2	VOLVO	33044	VOLVO	6 (→ 1338), 7 (→ 1338)
13281472	VOLVO	33044	VOLVO	6 (→ 1338), 7 (→ 1338)
1331285	FORD	50 006 145	FORD	87 (→ 318), ... , 94 (→ 321)
1349547	FORD	50 007 102	FORD	121 (→ 334), ... , 124 (→ 335)
1349548	FORD	50 007 085	FORD	90 (→ 319), ... , 106 (→ 326)
1349549	FORD	50 007 101	FORD	121 (→ 334), ... , 124 (→ 335)
1349550	FORD	50 007 095	FORD	90 (→ 319), ... , 106 (→ 326)
1352129	FORD	18375	FORD	69 (→ 312), ... , 72 (→ 314)
1366490	VOLVO	47130	VOLVO	16 (→ 1340), ... , 40 (→ 1347)
1366842	VOLVO	50 007 605	VOLVO	16 (→ 1340), ... , 37 (→ 1346)
1366882	VOLVO	47130	VOLVO	16 (→ 1340), ... , 40 (→ 1347)
1366882-7	VOLVO	47130	VOLVO	16 (→ 1340), ... , 40 (→ 1347)
13668827	VOLVO	47130	VOLVO	16 (→ 1340), ... , 40 (→ 1347)
1369828	FORD	471206	FORD	67 (→ 312), ... , 76 (→ 315)
1369831	FORD	471209	FORD	67 (→ 312), ... , 76 (→ 315)
1372430	FORD	50 007 051	FORD	107 (→ 327)
1372476	FORD	50 007 651	FORD	107 (→ 327), ... , 127 (→ 338)
1372743	FORD	50 007 687	FORD	111 (→ 330), 112 (→ 331)
1372744	FORD	50 007 028	FORD	126 (→ 337), 127 (→ 338)
1374186	FORD	181108	FORD	115 (→ 333)
1376413	FORD	181019	FORD	90 (→ 319), ... , 128 (→ 339)
1378960	VOLVO	81-47113	VOLVO	53 (→ 1350), ... , 64 (→ 1354)
1386533	FORD	50 007 081	FORD	13 (→ 296)
1386533	FORD	50 007 083	FORD	13 (→ 296)
1397641	VOLVO	47145	VOLVO	16 (→ 1340), ... , 40 (→ 1347)
1397641-0	VOLVO	47145	VOLVO	16 (→ 1340), ... , 40 (→ 1347)
13976410	VOLVO	47145	VOLVO	16 (→ 1340), ... , 40 (→ 1347)
1425513	FORD	50 007 651	FORD	107 (→ 327), ... , 127 (→ 338)
1425513	FORD	50 007 653	FORD	107 (→ 327), ... , 127 (→ 338)
1426035	FORD	50 006 418	FORD	46 (→ 307), 47 (→ 307)
1450604	FORD	50 006 494	FORD	90 (→ 319), ... , 98 (→ 323)
1487788	FORD	50 006 432	FORD	12 (→ 296), ... , 25 (→ 300)
1495923	FORD	50 007 099	FORD	87 (→ 318)
1535539	VOLVO	20100412003	VOLVO	103 (→ 1371), ... , 135 (→ 1391)
1538733	FORD	50 006 438	FORD	3 (→ 292)
1538735	FORD	291111	FORD	2 (→ 292)
154 52 90	VOLVO	105-35037	VOLVO	103 (→ 1371), ... , 108 (→ 1375)
1543026	VOLVO	48260	VOLVO	173 (→ 1414), 175 (→ 1415)
1543027	VOLVO	48256	VOLVO	173 (→ 1414), 175 (→ 1415)
1543078	VOLVO	RK-9.5H	VOLVO	173 (→ 1414), 175 (→ 1415)
15450711	VOLVO	20100410200	VOLVO	106 (→ 1374), 111 (→ 1377)
1545135	VOLVO	81-47104	VOLVO	102 (→ 1370), ... , 135 (→ 1390)
1545160	FORD	50 007 687	FORD	111 (→ 330), 112 (→ 331)



# ALPHANUMERICAL LIST

Reference	Item No.	Pos (→  )
15455397	VOLVO	20100412001 VOLVO 103 (→ 1371), ... , 135 (→ 1391)
15455405	VOLVO	20100412001 VOLVO 103 (→ 1371), ... , 135 (→ 1391)
1545885	VOLVO	92-47016 VOLVO 102 (→ 1370), ... , 112 (→ 1377)
1545886	VOLVO	92-47015 VOLVO 102 (→ 1370), ... , 112 (→ 1377)
1546437	VOLVO	81-47114 VOLVO 55 (→ 1351), ... , 172 (→ 1414)
1546437	VOLVO	81-47119 VOLVO 55 (→ 1351), ... , 171 (→ 1413)
1547492	VOLVO	48225 VOLVO 136 (→ 1391), ... , 145 (→ 1397)
1547583	VOLVO	92-47027 VOLVO 147 (→ 1399)
1547810	VOLVO	92-47026 VOLVO 147 (→ 1399)
1556472	VOLVO	48260 VOLVO 173 (→ 1414), 175 (→ 1415)
1556473	VOLVO	48256 VOLVO 173 (→ 1414), 175 (→ 1415)
1556604	VOLVO	81-47108 VOLVO 173 (→ 1414)
1556607	VOLVO	81-47107 VOLVO 173 (→ 1414)
1556813	VOLVO	48260 VOLVO 173 (→ 1414), 175 (→ 1415)
1556896	VOLVO	48256 VOLVO 173 (→ 1414), 175 (→ 1415)
1556947	VOLVO	20100416001 VOLVO 173 (→ 1414)
1584019	FORD	181109 FORD 115 (→ 333)
1584022	FORD	181108 FORD 115 (→ 333)
1584660	FORD	50 006 257 FORD 100 (→ 323), ... , 135 (→ 341)
1594826	FORD	50 006 096 FORD 87 (→ 318), ... , 89 (→ 318)
1614766	FORD	50 006 259 FORD 17 (→ 298), ... , 62 (→ 311)
1639605	FORD	181102 FORD 13 (→ 296), ... , 15 (→ 297)
1669766	FORD	39423 FORD 44 (→ 306)
1669772	FORD	331142 FORD 44 (→ 306)
1675716	FORD	181105 FORD 87 (→ 318), ... , 94 (→ 321)
1677875	VOLVO	RK-8H VOLVO 66 (→ 1355), ... , 148 (→ 1399)
1683701	FORD	181117 FORD 92 (→ 320), ... , 94 (→ 321)
1683702	FORD	50 007 628 FORD 92 (→ 320), 94 (→ 321)
1684538	FORD	50 007 627 FORD 92 (→ 320), 94 (→ 321)
1685737	FORD	50 007 674 FORD 23 (→ 300)
1685845	FORD	539047 FORD 11 (→ 295), ... , 26 (→ 301)
1685847	FORD	539046 FORD 11 (→ 295), ... , 26 (→ 301)
1688419	FORD	50 007 101 FORD 121 (→ 334), ... , 124 (→ 335)
1688422	FORD	50 007 050 FORD 107 (→ 327)
1698383	FORD	539051 FORD 90 (→ 319), 97 (→ 323)
1704531	FORD	50 007 687 FORD 111 (→ 330), 112 (→ 331)
1706989	FORD	181019 FORD 90 (→ 319), ... , 128 (→ 339)
1706990	FORD	181019 FORD 90 (→ 319), ... , 128 (→ 339)
1707012	FORD	50 007 096 FORD 87 (→ 318)
1719116	FORD	50 007 653 FORD 107 (→ 327), ... , 127 (→ 338)
1724837	FORD	50 007 800 FORD 1 (→ 292), 2 (→ 292)
1731706	FORD	50 007 686 FORD 111 (→ 330), 112 (→ 331)
1738494	FORD	181018 FORD 90 (→ 319), ... , 128 (→ 339)
1756382	FORD	50 007 653 FORD 107 (→ 327), ... , 127 (→ 338)
1760579	FORD	181120 FORD 8 (→ 294), 9 (→ 294)
1760588	FORD	181118 FORD 8 (→ 294), 9 (→ 294)
1771608	FORD	50 007 778 FORD 9 (→ 294)
1871583	FORD	539051 FORD 90 (→ 319), 97 (→ 323)
1871590	FORD	539050 FORD 90 (→ 319), 97 (→ 323)
1904655	FIAT	17076 FIAT 135 (→ 255), 136 (→ 256)
1904656	FIAT	17075 FIAT 135 (→ 255), 136 (→ 256)
1904666	FIAT	17076 FIAT 135 (→ 255), 136 (→ 256)
1908394	FIAT	171019 FIAT 137 (→ 256)
1908408	FIAT	17075 FIAT 135 (→ 255), 136 (→ 256)
1908410	FIAT	17076 FIAT 135 (→ 255), 136 (→ 256)
1908427	FIAT	171018 FIAT 138 (→ 256)
1S4G 6507 BA	FORD	181115 FORD 32 (→ 302)
1S4G 6507 BB	FORD	181115 FORD 32 (→ 302)
1S4G 6507 CA	FORD	181106 FORD 40 (→ 304), 42 (→ 305)
1S4G 6507 CB	FORD	181106 FORD 40 (→ 304), 42 (→ 305)
1S6G 6505 AA	FORD	181113 FORD 6 (→ 292), 7 (→ 293)
1S6G 6505 BA	FORD	181107 FORD 32 (→ 302), ... , 42 (→ 305)
1S6G 6507 AB	FORD	181112 FORD 6 (→ 292), 7 (→ 293)
1S7G 6505 C7F	FORD	181109 FORD 115 (→ 333)
1S7G 6505 CE	FORD	181109 FORD 115 (→ 333)



# ALPHANUMERICAL LIST

Reference	Item No.	Pos (→  )
1S7G 6505 CF FORD	181109	FORD 115 (→ 333)
1S7G 6505 DF FORD	181111	FORD 75 (→ 315)
1S7G 6507 C7G FORD	181108	FORD 115 (→ 333)
1S7G 6507 CE FORD	181108	FORD 115 (→ 333)
1S7G 6507 CF FORD	181108	FORD 115 (→ 333)
1S7G 6507 CG FORD	181108	FORD 115 (→ 333)
1S7G 6507 DG FORD	181110	FORD 75 (→ 315)
2 440 5815 FIAT	291118	FIAT 43 (→ 226)
20355012 VOLVO	81-47107	VOLVO 173 (→ 1414)
20355015 VOLVO	81-47108	VOLVO 173 (→ 1414)
20381702 VOLVO	20100412101	VOLVO 136 (→ 1391), ... , 167 (→ 1412)
20405502 VOLVO	22221	VOLVO 84 (→ 1361), ... , 90 (→ 1364)
20405503 VOLVO	22220	VOLVO 84 (→ 1361), ... , 90 (→ 1364)
20405897 VOLVO	81-22110	VOLVO 84 (→ 1361), ... , 87 (→ 1362)
20412798 VOLVO	92-47020	VOLVO 58 (→ 1352), ... , 176 (→ 1415)
20441486 VOLVO	48227	VOLVO 136 (→ 1391), ... , 148 (→ 1399)
20441945 VOLVO	48328	VOLVO 137 (→ 1392), ... , 142 (→ 1396)
20450002 VOLVO	48308	VOLVO 94 (→ 1366), ... , 101 (→ 1370)
20451774 VOLVO	20100409001	VOLVO 94 (→ 1366)
20451775 VOLVO	20100409000	VOLVO 94 (→ 1366), ... , 119 (→ 1383)
20459326 VOLVO	48327	VOLVO 137 (→ 1392), ... , 148 (→ 1399)
20459329 VOLVO	92-47019	VOLVO 58 (→ 1352), ... , 176 (→ 1415)
20459329 VOLVO	92-47026	VOLVO 147 (→ 1399)
20459962 VOLVO	92-22005	VOLVO 84 (→ 1361), ... , 87 (→ 1363)
20459963 VOLVO	92-22006	VOLVO 84 (→ 1361), ... , 87 (→ 1363)
20463800 VOLVO	48327	VOLVO 137 (→ 1392), ... , 148 (→ 1399)
20464020 VOLVO	48314	VOLVO 55 (→ 1351), ... , 120 (→ 1383)
20482579 VOLVO	92-47019	VOLVO 58 (→ 1352), ... , 176 (→ 1415)
20509465 VOLVO	92-47030	VOLVO 55 (→ 1351), ... , 120 (→ 1383)
20510747 VOLVO	MK-8H	VOLVO 6 (→ 1338), ... , 172 (→ 1414)
20513284 VOLVO	48330	VOLVO 177 (→ 1416), ... , 182 (→ 1418)
20513285 VOLVO	48330	VOLVO 177 (→ 1416), ... , 182 (→ 1418)
20516141 VOLVO	48309	VOLVO 94 (→ 1366), ... , 101 (→ 1370)
20528110 VOLVO	48308	VOLVO 94 (→ 1366), ... , 101 (→ 1370)
20528111 VOLVO	48308	VOLVO 94 (→ 1366), ... , 101 (→ 1370)
20528113 VOLVO	48310	VOLVO 93 (→ 1365), ... , 101 (→ 1370)
20530103 VOLVO	92-47029	VOLVO 150 (→ 1401), ... , 168 (→ 1412)
20540012 VOLVO	48313	VOLVO 55 (→ 1351), ... , 120 (→ 1383)
20540013 VOLVO	48313	VOLVO 55 (→ 1351), ... , 120 (→ 1383)
20540017 VOLVO	48313	VOLVO 55 (→ 1351), ... , 120 (→ 1383)
20541405 VOLVO	92-47029	VOLVO 150 (→ 1401), ... , 168 (→ 1412)
20551761 VOLVO	48310	VOLVO 93 (→ 1365), ... , 101 (→ 1370)
20555102 VOLVO	92-47023	VOLVO 94 (→ 1366), ... , 101 (→ 1370)
20555104 VOLVO	92-47024	VOLVO 94 (→ 1366), ... , 101 (→ 1370)
20561995 VOLVO	48315	VOLVO 150 (→ 1400), ... , 172 (→ 1414)
20561997 VOLVO	92-47028	VOLVO 150 (→ 1401), ... , 168 (→ 1412)
20562837 VOLVO	81-47120	VOLVO 177 (→ 1416), ... , 182 (→ 1418)
20564019 VOLVO	48314	VOLVO 55 (→ 1351), ... , 120 (→ 1383)
20564020 VOLVO	48314	VOLVO 55 (→ 1351), ... , 120 (→ 1383)
20564028 VOLVO	92-47037	VOLVO 178 (→ 1417), ... , 182 (→ 1418)
20564039 VOLVO	48312	VOLVO 93 (→ 1365), 99 (→ 1369)
20565912 VOLVO	22220	VOLVO 84 (→ 1361), ... , 90 (→ 1364)
20570965 VOLVO	48311	VOLVO 94 (→ 1366), ... , 101 (→ 1370)
20576909 VOLVO	20100412009	VOLVO 149 (→ 1400)
20709467 VOLVO	92-47036	VOLVO 178 (→ 1417), ... , 182 (→ 1418)
20712128 VOLVO	48315	VOLVO 150 (→ 1400), ... , 172 (→ 1414)
20714469 VOLVO	22221	VOLVO 84 (→ 1361), ... , 90 (→ 1364)
20732758 VOLVO	92-47031	VOLVO 55 (→ 1351), ... , 120 (→ 1383)
20735572 VOLVO	48317	VOLVO 177 (→ 1416)
20735573 VOLVO	48317	VOLVO 177 (→ 1416)
20737856 VOLVO	48313	VOLVO 55 (→ 1351), ... , 120 (→ 1383)
20738717 VOLVO	20100412100	VOLVO 136 (→ 1391), ... , 140 (→ 1395)
20738736 VOLVO	20100412102	VOLVO 136 (→ 1391), ... , 168 (→ 1412)
20738748 VOLVO	20100412101	VOLVO 136 (→ 1391), ... , 167 (→ 1412)
20739057 VOLVO	48319	VOLVO 177 (→ 1416), ... , 182 (→ 1418)

# ALPHANUMERICAL LIST

Reference	Item No.	Pos (→  )
20739058	VOLVO	48319 VOLVO 177 (→ 1416), ... , 182 (→ 1418)
20740798	VOLVO	48315 VOLVO 150 (→ 1400), ... , 172 (→ 1414)
20740804	VOLVO	92-47028 VOLVO 150 (→ 1401), ... , 168 (→ 1412)
20742607	VOLVO	20100413004 VOLVO 164 (→ 1410)
20742610	VOLVO	20100413000 VOLVO 152 (→ 1403), 153 (→ 1404)
20746807	VOLVO	20100411001 VOLVO 113 (→ 1378), ... , 117 (→ 1381)
20746808	VOLVO	20100411000 VOLVO 113 (→ 1378), ... , 117 (→ 1381)
20757636	VOLVO	20100413002 VOLVO 150 (→ 1401), 157 (→ 1406)
20758404	VOLVO	20100413003 VOLVO 164 (→ 1410)
20768519	VOLVO	48316 VOLVO 150 (→ 1400), ... , 172 (→ 1414)
20789674	VOLVO	81-22113 VOLVO 83 (→ 1360), ... , 89 (→ 1363)
20795692	VOLVO	20100407100 VOLVO 88 (→ 1363)
20795696	VOLVO	20100407100 VOLVO 88 (→ 1363)
20798533	VOLVO	22308 VOLVO 65 (→ 1354), 70 (→ 1356)
20798699	VOLVO	22307 VOLVO 65 (→ 1354), 70 (→ 1356)
20817645	VOLVO	81-47114 VOLVO 55 (→ 1351), ... , 172 (→ 1414)
20817645	VOLVO	81-47119 VOLVO 55 (→ 1351), ... , 171 (→ 1413)
20817648	VOLVO	81-47114 VOLVO 55 (→ 1351), ... , 172 (→ 1414)
20817648	VOLVO	81-47119 VOLVO 55 (→ 1351), ... , 171 (→ 1413)
20833927	VOLVO	92-22019 VOLVO 83 (→ 1360), ... , 89 (→ 1363)
20833930	VOLVO	92-22020 VOLVO 83 (→ 1360), ... , 89 (→ 1363)
20833932	VOLVO	22316 VOLVO 83 (→ 1360), ... , 89 (→ 1363)
20833936	VOLVO	22317 VOLVO 83 (→ 1360), ... , 89 (→ 1363)
20845144	VOLVO	92-22006 VOLVO 84 (→ 1361), ... , 87 (→ 1363)
20849976	VOLVO	92-22013 VOLVO 65 (→ 1354), 70 (→ 1356)
20849979	VOLVO	92-22014 VOLVO 65 (→ 1354), 70 (→ 1356)
20904074	VOLVO	81-47114 VOLVO 55 (→ 1351), ... , 172 (→ 1414)
20904074	VOLVO	81-47119 VOLVO 55 (→ 1351), ... , 171 (→ 1413)
20905400	VOLVO	81-47114 VOLVO 55 (→ 1351), ... , 172 (→ 1414)
20905400	VOLVO	81-47119 VOLVO 55 (→ 1351), ... , 171 (→ 1413)
20915925	VOLVO	20100413006 VOLVO 150 (→ 1401), ... , 163 (→ 1410)
20916916	VOLVO	81-47120 VOLVO 177 (→ 1416), ... , 182 (→ 1418)
20919484	VOLVO	81-47114 VOLVO 55 (→ 1351), ... , 172 (→ 1414)
20919484	VOLVO	81-47119 VOLVO 55 (→ 1351), ... , 171 (→ 1413)
20920956	VOLVO	20100413006 VOLVO 150 (→ 1401), ... , 163 (→ 1410)
20950804	VOLVO	20100416003 VOLVO 182 (→ 1418)
20980413	VOLVO	22316 VOLVO 83 (→ 1360), ... , 89 (→ 1363)
20997871	VOLVO	22317 VOLVO 83 (→ 1360), ... , 89 (→ 1363)
21016539	VOLVO	48316 VOLVO 150 (→ 1400), ... , 172 (→ 1414)
21023450	VOLVO	20100412101 VOLVO 136 (→ 1391), ... , 167 (→ 1412)
21024789	VOLVO	20100412102 VOLVO 136 (→ 1391), ... , 168 (→ 1412)
21024794	VOLVO	20100412100 VOLVO 136 (→ 1391), ... , 140 (→ 1395)
21067953	VOLVO	81-47120 VOLVO 177 (→ 1416), ... , 182 (→ 1418)
21087443	VOLVO	92-22019 VOLVO 83 (→ 1360), ... , 89 (→ 1363)
21089229	VOLVO	20100412101 VOLVO 136 (→ 1391), ... , 167 (→ 1412)
21110437	VOLVO	20100413005 VOLVO 150 (→ 1401), ... , 163 (→ 1410)
21110842	VOLVO	20100413001 VOLVO 157 (→ 1406)
21110845	VOLVO	20100413002 VOLVO 150 (→ 1401), 157 (→ 1406)
21154172	VOLVO	20100413100 VOLVO 158 (→ 1407), ... , 170 (→ 1413)
21189194	VOLVO	20100411002 VOLVO 113 (→ 1378)
21198713	VOLVO	20100413007 VOLVO 153 (→ 1404)
21311517	VOLVO	20100407100 VOLVO 88 (→ 1363)
21341222	VOLVO	20100407100 VOLVO 88 (→ 1363)
21344665	VOLVO	81-22110 VOLVO 84 (→ 1361), ... , 87 (→ 1362)
21378520	VOLVO	20100413009 VOLVO 150 (→ 1401), ... , 163 (→ 1410)
21426367	VOLVO	20100407100 VOLVO 88 (→ 1363)
21427620	VOLVO	48313 VOLVO 55 (→ 1351), ... , 120 (→ 1383)
21428655	VOLVO	48315 VOLVO 150 (→ 1400), ... , 172 (→ 1414)
21428679	VOLVO	48337 VOLVO 156 (→ 1405), 162 (→ 1409)
21430916	VOLVO	48312 VOLVO 93 (→ 1365), 99 (→ 1369)
21430918	VOLVO	48314 VOLVO 55 (→ 1351), ... , 120 (→ 1383)
21451261	VOLVO	20100407100 VOLVO 88 (→ 1363)
21456499	VOLVO	20010510140 VOLVO 89 (→ 1364)
21484829	VOLVO	92-47019 VOLVO 58 (→ 1352), ... , 176 (→ 1415)
21484829	VOLVO	92-47026 VOLVO 147 (→ 1399)

Reference	Item No.	Pos (→  )		
21484834	VOLVO	92-47020	VOLVO	58 (→ 1352), ... , 176 (→ 1415)
21484834	VOLVO	92-47027	VOLVO	147 (→ 1399)
21486078	VOLVO	20010510140	VOLVO	89 (→ 1364)
21504759	VOLVO	20100412101	VOLVO	136 (→ 1391), ... , 167 (→ 1412)
21528642	VOLVO	48335	VOLVO	91 (→ 1364)
21528644	VOLVO	48336	VOLVO	91 (→ 1364)
21528645	VOLVO	48336	VOLVO	91 (→ 1364)
21698059	VOLVO	20100413008	VOLVO	156 (→ 1405)
21705499	VOLVO	81-22113	VOLVO	83 (→ 1360), ... , 89 (→ 1363)
21739130	VOLVO	22315	VOLVO	85 (→ 1362), 87 (→ 1362)
21745877	VOLVO	20100411003	VOLVO	115 (→ 1380)
21881195	VOLVO	20100412101	VOLVO	136 (→ 1391), ... , 167 (→ 1412)
21894469	VOLVO	22316	VOLVO	83 (→ 1360), ... , 89 (→ 1363)
21896344	VOLVO	22314	VOLVO	85 (→ 1362), 87 (→ 1362)
22 41 0 411 804	BMW	81-1116	BMW	2 (→ 165)
22103846	VOLVO	81-47123	VOLVO	91 (→ 1364), 92 (→ 1365)
22176515	VOLVO	20010510140	VOLVO	89 (→ 1364)
22258001	VOLVO	20100413004	VOLVO	164 (→ 1410)
22431872	VOLVO	20100411002	VOLVO	113 (→ 1378)
22431873	VOLVO	20100411001	VOLVO	113 (→ 1378), ... , 117 (→ 1381)
22431874	VOLVO	20100411000	VOLVO	113 (→ 1378), ... , 117 (→ 1381)
22431875	VOLVO	20100413004	VOLVO	164 (→ 1410)
22431876	VOLVO	20100413008	VOLVO	156 (→ 1405)
22431879	VOLVO	20100413009	VOLVO	150 (→ 1401), ... , 163 (→ 1410)
22431881	VOLVO	20100413005	VOLVO	150 (→ 1401), ... , 163 (→ 1410)
22431882	VOLVO	20100413006	VOLVO	150 (→ 1401), ... , 163 (→ 1410)
22431883	VOLVO	20100413001	VOLVO	157 (→ 1406)
22431885	VOLVO	20100413002	VOLVO	150 (→ 1401), 157 (→ 1406)
22431886	VOLVO	20100413000	VOLVO	152 (→ 1403), 153 (→ 1404)
22431887	VOLVO	20100413003	VOLVO	164 (→ 1410)
22431891	VOLVO	20100416003	VOLVO	182 (→ 1418)
22486978	VOLVO	20100413010	VOLVO	162 (→ 1409)
22494872	VOLVO	81-22113	VOLVO	83 (→ 1360), ... , 89 (→ 1363)
22583038	VOLVO	48335	VOLVO	91 (→ 1364)
22584592	VOLVO	20100411002	VOLVO	113 (→ 1378)
22584593	VOLVO	20100411001	VOLVO	113 (→ 1378), ... , 117 (→ 1381)
22584594	VOLVO	20100411000	VOLVO	113 (→ 1378), ... , 117 (→ 1381)
22584596	VOLVO	20100413009	VOLVO	150 (→ 1401), ... , 163 (→ 1410)
22584597	VOLVO	20100413005	VOLVO	150 (→ 1401), ... , 163 (→ 1410)
22584599	VOLVO	20100413001	VOLVO	157 (→ 1406)
22584601	VOLVO	20100413002	VOLVO	150 (→ 1401), 157 (→ 1406)
22584602	VOLVO	20100413000	VOLVO	152 (→ 1403), 153 (→ 1404)
22584603	VOLVO	20100413003	VOLVO	164 (→ 1410)
22686466	VOLVO	48314	VOLVO	55 (→ 1351), ... , 120 (→ 1383)
2325380	FORD	50 007 780	FORD	80 (→ 316), 81 (→ 316)
23289160	VOLVO	20100413009	VOLVO	150 (→ 1401), ... , 163 (→ 1410)
23289181	VOLVO	20100413010	VOLVO	162 (→ 1409)
23289200	VOLVO	20100411003	VOLVO	115 (→ 1380)
23289202	VOLVO	20100413008	VOLVO	156 (→ 1405)
24 01 0 411 819	BMW	81-1119	BMW	2 (→ 165)
24 01 0 411 829	BMW	81-1120	BMW	2 (→ 165)
24426433	VOLVO	48319	VOLVO	177 (→ 1416), ... , 182 (→ 1418)
245390	VOLVO	536226	VOLVO	49 (→ 1349), 56 (→ 1351)
245390-0	VOLVO	536226	VOLVO	49 (→ 1349), 56 (→ 1351)
2453900	VOLVO	536226	VOLVO	49 (→ 1349), 56 (→ 1351)
245802	VOLVO	538930	VOLVO	49 (→ 1349), 56 (→ 1351)
245802-4	VOLVO	538930	VOLVO	49 (→ 1349), 56 (→ 1351)
2458024	VOLVO	538930	VOLVO	49 (→ 1349), 56 (→ 1351)
2S6Q 6250 AD	FORD	50 007 081	FORD	13 (→ 296)
2S6Q 6250 AD	FORD	50 007 083	FORD	13 (→ 296)
2S6Q 6505 AA	FORD	181103	FORD	13 (→ 296), ... , 15 (→ 297)
2S6Q 6505 AB	FORD	181103	FORD	13 (→ 296), ... , 15 (→ 297)
2S6Q 6505 AC	FORD	181103	FORD	13 (→ 296), ... , 15 (→ 297)
2S6Q 6507 A9B	FORD	181102	FORD	13 (→ 296), ... , 15 (→ 297)
2S6Q 6507 AA	FORD	181102	FORD	13 (→ 296), ... , 15 (→ 297)

# ALPHANUMERICAL LIST

Reference	Item No.	Pos (→  )
2S6Q 6507 AB FORD	181102	FORD 13 (→ 296), ... , 15 (→ 297)
2S6Q-6564-AA FORD	50 006 172	FORD 13 (→ 297)
2S6Q6500AA FORD	50 006 432	FORD 12 (→ 296), ... , 25 (→ 300)
2S6Q6500AB FORD	50 006 432	FORD 12 (→ 296), ... , 25 (→ 300)
2S7Q 6505 A1B FORD	181019	FORD 90 (→ 319), ... , 128 (→ 339)
2S7Q 6505 A2A FORD	181019	FORD 90 (→ 319), ... , 128 (→ 339)
2S7Q 6505 AC FORD	181019	FORD 90 (→ 319), ... , 128 (→ 339)
30711497 VOLVO	539010	VOLVO 3 (→ 1337)
30711498 VOLVO	539009	VOLVO 3 (→ 1337)
30711499 VOLVO	50 006 433	VOLVO 3 (→ 1337)
30711638 VOLVO	181107	VOLVO 9 (→ 1339)
30711639 VOLVO	181106	VOLVO 9 (→ 1339)
30777328 VOLVO	181109	VOLVO 46 (→ 1349)
30777329 VOLVO	181108	VOLVO 46 (→ 1349)
3101039 VOLVO	MK-7H2	VOLVO 1 (→ 1337), ... , 5 (→ 1338)
3101039-0 VOLVO	MK-7H2	VOLVO 1 (→ 1337), ... , 5 (→ 1338)
3102891 VOLVO	81-5115	VOLVO 1 (→ 1337), ... , 5 (→ 1338)
3104400 VOLVO	KK-7H	VOLVO 1 (→ 1337), ... , 30 (→ 1344)
3104400-1 VOLVO	KK-7H	VOLVO 1 (→ 1337), ... , 30 (→ 1344)
311 109 601 VOLKSWAGEN	33009	VOLKSWAGEN 118 (→ 1166), ... , 380 (→ 1275)
311 109 612 A VOLKSWAGEN	33008	VOLKSWAGEN 119 (→ 1167), ... , 378 (→ 1274)
31330181 VOLVO	539046	VOLVO 4 (→ 1337)
31330182 VOLVO	539047	VOLVO 4 (→ 1337)
31375168 VOLVO	471203	VOLVO 28 (→ 1344)
31375493 VOLVO	471210	VOLVO 27 (→ 1343), ... , 47 (→ 1349)
31375602 VOLVO	471202	VOLVO 28 (→ 1344)
31375630 VOLVO	471200	VOLVO 27 (→ 1343), ... , 47 (→ 1349)
31480436 VOLVO	471210	VOLVO 27 (→ 1343), ... , 47 (→ 1349)
316 5224 VOLVO	20100412006	VOLVO 138 (→ 1393), ... , 143 (→ 1397)
3165234 VOLVO	48227	VOLVO 136 (→ 1391), ... , 148 (→ 1399)
3165303 VOLVO	81-47114	VOLVO 55 (→ 1351), ... , 172 (→ 1414)
3165303 VOLVO	81-47119	VOLVO 55 (→ 1351), ... , 171 (→ 1413)
3165369 VOLVO	92-47027	VOLVO 147 (→ 1399)
3165423 VOLVO	20100412005	VOLVO 137 (→ 1392), 138 (→ 1393)
3169366 VOLVO	92-47020	VOLVO 58 (→ 1352), ... , 176 (→ 1415)
3169366 VOLVO	92-47027	VOLVO 147 (→ 1399)
3169490 VOLVO	48225	VOLVO 136 (→ 1391), ... , 145 (→ 1397)
3183227 VOLVO	92-47026	VOLVO 147 (→ 1399)
3183283 VOLVO	81-47114	VOLVO 55 (→ 1351), ... , 172 (→ 1414)
3183283 VOLVO	81-47119	VOLVO 55 (→ 1351), ... , 171 (→ 1413)
3342399 VOLVO	517981	VOLVO 14 (→ 1339), ... , 30 (→ 1344)
3342399-7 VOLVO	517981	VOLVO 14 (→ 1339), ... , 30 (→ 1344)
33423997 VOLVO	517981	VOLVO 14 (→ 1339), ... , 30 (→ 1344)
3343624 VOLVO	81-47103	VOLVO 14 (→ 1339), ... , 31 (→ 1344)
3343738 VOLVO	517981	VOLVO 14 (→ 1339), ... , 30 (→ 1344)
3343738-5 VOLVO	517981	VOLVO 14 (→ 1339), ... , 30 (→ 1344)
33437385 VOLVO	517981	VOLVO 14 (→ 1339), ... , 30 (→ 1344)
3344841 VOLVO	510201	VOLVO 31 (→ 1344)
3344841-6 VOLVO	510201	VOLVO 31 (→ 1344)
3344842 VOLVO	510202	VOLVO 31 (→ 1344)
3344842-4 VOLVO	510202	VOLVO 31 (→ 1344)
3395984 FORD	50 007 664	FORD 77 (→ 315)
3547603 VOLVO	81-4719	VOLVO 29 (→ 1344), ... , 63 (→ 1354)
3720224 FORD	50 007 664	FORD 77 (→ 315)
3842972 VOLVO	48314	VOLVO 55 (→ 1351), ... , 120 (→ 1383)
3943449 FIAT	92-17000	FIAT 130 (→ 253)
3943450 FIAT	92-17001	FIAT 130 (→ 253)
3964764 VOLVO	20100412008	VOLVO 136 (→ 1391), 141 (→ 1395)
3965955 VOLVO	92-47038	VOLVO 178 (→ 1417)
3978768 VOLVO	48322	VOLVO 74 (→ 1358), ... , 80 (→ 1359)
3M5Q 6505 AA FORD	539010	FORD 20 (→ 298), ... , 22 (→ 299)
3M5Q 6505 BA FORD	181105	FORD 87 (→ 318), ... , 94 (→ 321)
3M5Q 6507 AA FORD	539009	FORD 20 (→ 298), ... , 22 (→ 299)
3M5Q 6507 BA FORD	181104	FORD 87 (→ 318), 88 (→ 318)
3M5Q 6564 AA FORD	50 006 485	FORD 22 (→ 299)

Reference	Item No.	Pos (→  )
3M5Q 6A273 BB FORD	50 007 099	FORD 87 (→ 318)
3M5Q-6A270-BB FORD	50 007 096	FORD 87 (→ 318)
3M5Q6500AB FORD	50 006 145	FORD 87 (→ 318), ... , 94 (→ 321)
3M5Q6500BA FORD	50 006 433	FORD 22 (→ 299)
3M5Q6564BB FORD	50 006 096	FORD 87 (→ 318), ... , 89 (→ 318)
3M5Q6A270AC FORD	50 007 093	FORD 22 (→ 299)
3M5Q6A270AC FORD	50 007 573	FORD 22 (→ 299)
3M5Q6A273AC FORD	50 007 094	FORD 22 (→ 299)
3M5Q6A273AC FORD	50 007 574	FORD 22 (→ 299)
4 250 803 FIAT	81-17110	FIAT 2 (→ 218), ... , 92 (→ 240)
4 371 508 FIAT	81-1762	FIAT 2 (→ 218), ... , 92 (→ 240)
4 372 331 FIAT	81-1755	FIAT 1 (→ 218), ... , 94 (→ 241)
4 621 484 FIAT	17043	FIAT 119 (→ 250), ... , 134 (→ 254)
4 641 3806 FIAT	171036	FIAT 42 (→ 226), ... , 94 (→ 241)
4 641 3807 FIAT	171043	FIAT 89 (→ 239), ... , 94 (→ 241)
4 646 2158 FIAT	171036	FIAT 42 (→ 226), ... , 94 (→ 241)
4 646 2159 FIAT	171043	FIAT 89 (→ 239), ... , 94 (→ 241)
4 648 421 FIAT	81-17117	FIAT 119 (→ 250), ... , 139 (→ 257)
4 651 7325 FIAT	171036	FIAT 42 (→ 226), ... , 94 (→ 241)
4 652 7856 FIAT	171014	FIAT 50 (→ 228)
4 659 379 FIAT	50 004 282	FIAT 119 (→ 250), ... , 133 (→ 254)
4 676 1369 FIAT	171036	FIAT 42 (→ 226), ... , 94 (→ 241)
4 676 1370 FIAT	171043	FIAT 89 (→ 239), ... , 94 (→ 241)
4 726 483 FIAT	81-17114	FIAT 98 (→ 242), ... , 118 (→ 249)
4 733 258 FIAT	81-17114	FIAT 98 (→ 242), ... , 118 (→ 249)
4 733 349 FIAT	17032	FIAT 101 (→ 243), ... , 107 (→ 244)
4 749 395 FIAT	81-17116	FIAT 98 (→ 242), ... , 118 (→ 249)
4 749 397 FIAT	81-17115	FIAT 98 (→ 242), ... , 118 (→ 249)
4 749 398 FIAT	81-5611	FIAT 98 (→ 242), ... , 118 (→ 249)
4 802 126 FIAT	81-17117	FIAT 119 (→ 250), ... , 139 (→ 257)
4 826 033 FIAT	17063	FIAT 104 (→ 244), ... , 113 (→ 247)
4 895 051 FIAT	105-35633	FIAT 130 (→ 253), 131 (→ 253)
4 895 052 FIAT	105-35632	FIAT 130 (→ 253), 131 (→ 253)
419643 VOLVO	MK-8H	VOLVO 6 (→ 1338), ... , 172 (→ 1414)
419652 VOLVO	81-4716	VOLVO 29 (→ 1344), ... , 63 (→ 1354)
419653 VOLVO	81-4717	VOLVO 29 (→ 1344), ... , 63 (→ 1354)
420553 VOLVO	48114	VOLVO 66 (→ 1355), 69 (→ 1355)
420553-0 VOLVO	48114	VOLVO 66 (→ 1355), 69 (→ 1355)
4205530 VOLVO	48114	VOLVO 66 (→ 1355), 69 (→ 1355)
421011 VOLVO	92-47001	VOLVO 71 (→ 1356), ... , 76 (→ 1358)
4210670 VOLVO	20100470000	VOLVO 60 (→ 1353), ... , 78 (→ 1359)
421297 VOLVO	81-47104	VOLVO 102 (→ 1370), ... , 135 (→ 1390)
421316 VOLVO	92-47002	VOLVO 71 (→ 1356), ... , 76 (→ 1358)
421680 VOLVO	48302	VOLVO 71 (→ 1356), 72 (→ 1357)
422011 VOLVO	92-47005	VOLVO 105 (→ 1373)
422012 VOLVO	92-47006	VOLVO 105 (→ 1373)
4223186 VOLVO	20100412001	VOLVO 103 (→ 1371), ... , 135 (→ 1391)
422320 VOLVO	81-47109	VOLVO 102 (→ 1370), ... , 135 (→ 1390)
4223632 VOLVO	20100410000	VOLVO 108 (→ 1375)
422762 VOLVO	81-47116	VOLVO 111 (→ 1377), 112 (→ 1377)
423011 VOLVO	92-47007	VOLVO 121 (→ 1384), ... , 135 (→ 1390)
423208 VOLVO	92-47008	VOLVO 121 (→ 1384), ... , 135 (→ 1390)
4265699 FIAT	81-1755	FIAT 1 (→ 218), ... , 94 (→ 241)
46 461 209 FIAT	171037	FIAT 42 (→ 226), ... , 94 (→ 241)
460803 VOLVO	48303	VOLVO 121 (→ 1383), ... , 135 (→ 1390)
460803-3 VOLVO	48303	VOLVO 121 (→ 1383), ... , 135 (→ 1390)
4630923 FIAT	81-17126	FIAT 145 (→ 259)
463395 VOLVO	4717	VOLVO 44 (→ 1348), ... , 62 (→ 1353)
463395-4 VOLVO	4717	VOLVO 44 (→ 1348), ... , 62 (→ 1353)
4633954 VOLVO	4717	VOLVO 44 (→ 1348), ... , 62 (→ 1353)
463526 VOLVO	4718	VOLVO 44 (→ 1348), ... , 62 (→ 1353)
463526-4 VOLVO	4718	VOLVO 44 (→ 1348), ... , 62 (→ 1353)
4635264 VOLVO	4718	VOLVO 44 (→ 1348), ... , 62 (→ 1353)
463771 VOLVO	81-4719	VOLVO 29 (→ 1344), ... , 63 (→ 1354)
46403681 FIAT	171052	FIAT 18 (→ 222)



# ALPHANUMERICAL LIST

Reference	Item No.	Pos (→  )		
46416321	FIAT	171062	FIAT	51 (→ 228), 52 (→ 229)
46427282	FIAT	50 007 616	FIAT	4 (→ 218)
46433782	FIAT	81-17128	FIAT	50 (→ 228), ... , 53 (→ 229)
46471599	FIAT	50 007 618	FIAT	47 (→ 227), 48 (→ 227)
46471639	FIAT	171053	FIAT	18 (→ 222)
46475925	FIAT	50 006 438	FIAT	7 (→ 219), ... , 69 (→ 234)
46478834	FIAT	171046	FIAT	51 (→ 228), 52 (→ 229)
4648237	FIAT	81-17127	FIAT	145 (→ 259)
465157	VOLVO	81-47106	VOLVO	66 (→ 1355), ... , 81 (→ 1360)
46518930	FIAT	291111	FIAT	7 (→ 219), ... , 10 (→ 220)
46518931	FIAT	291112	FIAT	7 (→ 219), ... , 10 (→ 220)
465284	VOLVO	RK-8	VOLVO	6 (→ 1338), ... , 69 (→ 1355)
465381	VOLVO	48302	VOLVO	71 (→ 1356), 72 (→ 1357)
465381-1	VOLVO	48302	VOLVO	71 (→ 1356), 72 (→ 1357)
46552984	FIAT	50 006 189	FIAT	63 (→ 232)
465548	VOLVO	48114	VOLVO	66 (→ 1355), 69 (→ 1355)
465549	VOLVO	48115	VOLVO	66 (→ 1355), 69 (→ 1355)
465549-4	VOLVO	48115	VOLVO	66 (→ 1355), 69 (→ 1355)
4655494	VOLVO	48115	VOLVO	66 (→ 1355), 69 (→ 1355)
4658055	FIAT	17043	FIAT	119 (→ 250), ... , 134 (→ 254)
466266	VOLVO	92-47003	VOLVO	71 (→ 1356), ... , 76 (→ 1358)
466307	VOLVO	92-47004	VOLVO	71 (→ 1356), ... , 76 (→ 1358)
466379	VOLVO	105-35099	VOLVO	71 (→ 1356), 72 (→ 1357)
466379-5	VOLVO	105-35099	VOLVO	71 (→ 1356), 72 (→ 1357)
4663795	VOLVO	105-35099	VOLVO	71 (→ 1356), 72 (→ 1357)
466386	VOLVO	81-47112	VOLVO	71 (→ 1356), ... , 76 (→ 1358)
4673608	FIAT	17043	FIAT	119 (→ 250), ... , 134 (→ 254)
4673861	FIAT	171110	FIAT	145 (→ 259)
467474	VOLVO	92-47011	VOLVO	102 (→ 1370), ... , 112 (→ 1377)
467475	VOLVO	92-47013	VOLVO	103 (→ 1371), ... , 111 (→ 1377)
467502	VOLVO	105-35037	VOLVO	103 (→ 1371), ... , 108 (→ 1375)
467502-1	VOLVO	105-35037	VOLVO	103 (→ 1371), ... , 108 (→ 1375)
4675021	VOLVO	105-35037	VOLVO	103 (→ 1371), ... , 108 (→ 1375)
467503	VOLVO	48151	VOLVO	103 (→ 1371), ... , 111 (→ 1377)
46750859	FIAT	171046	FIAT	51 (→ 228), 52 (→ 229)
467590	VOLVO	92-47012	VOLVO	102 (→ 1370), ... , 112 (→ 1377)
46764765	FIAT	50 007 613	FIAT	55 (→ 230)
46767972	FIAT	50 006 432	FIAT	54 (→ 229), ... , 79 (→ 237)
467682	VOLVO	48151	VOLVO	103 (→ 1371), ... , 111 (→ 1377)
46772393	FIAT	50 007 038	FIAT	51 (→ 228), ... , 56 (→ 230)
46783962	FIAT	171062	FIAT	51 (→ 228), 52 (→ 229)
4678538	VOLVO	20100410000	VOLVO	108 (→ 1375)
467855	VOLVO	48151	VOLVO	103 (→ 1371), ... , 111 (→ 1377)
467855-3	VOLVO	48151	VOLVO	103 (→ 1371), ... , 111 (→ 1377)
4678553	VOLVO	48151	VOLVO	103 (→ 1371), ... , 111 (→ 1377)
46787055	FIAT	50 006 422	FIAT	18 (→ 222), ... , 95 (→ 241)
46787902	FIAT	291115	FIAT	34 (→ 224), ... , 69 (→ 234)
46802049	FIAT	291113	FIAT	34 (→ 224), ... , 69 (→ 234)
46802052	FIAT	50 007 104	FIAT	54 (→ 229), 55 (→ 230)
46816601	FIAT	81-4221	FIAT	7 (→ 219), ... , 13 (→ 221)
46816601	LANCIA	81-4221	LANCIA	3 (→ 352), 4 (→ 352)
46823507	FIAT	50 007 024	FIAT	7 (→ 219), 9 (→ 220)
46823508	FIAT	50 007 572	FIAT	7 (→ 219), 9 (→ 220)
468302	VOLVO	105-34949	VOLVO	121 (→ 1383), ... , 135 (→ 1390)
468302-5	VOLVO	105-34949	VOLVO	121 (→ 1383), ... , 135 (→ 1390)
468303	VOLVO	48303	VOLVO	121 (→ 1383), ... , 135 (→ 1390)
468303-3	VOLVO	48303	VOLVO	121 (→ 1383), ... , 135 (→ 1390)
468305	VOLVO	RK-11H	VOLVO	71 (→ 1356), ... , 135 (→ 1390)
468448	VOLVO	92-47009	VOLVO	121 (→ 1384), ... , 135 (→ 1390)
4687232	VOLVO	20100412200	VOLVO	121 (→ 1384), ... , 135 (→ 1390)
47 57 358	FIAT	171120	FIAT	98 (→ 242), ... , 118 (→ 249)
471195	VOLVO	48302	VOLVO	71 (→ 1356), 72 (→ 1357)
471195-8	VOLVO	48302	VOLVO	71 (→ 1356), 72 (→ 1357)
4733350	FIAT	50 006 180	FIAT	98 (→ 242), ... , 118 (→ 250)
477443	VOLVO	48208	VOLVO	75 (→ 1358)



# ALPHANUMERICAL LIST

Reference		Item No.		Pos (→  )
477447	VOLVO	48207	VOLVO	75 (→ 1358)
477657	VOLVO	92-47021	VOLVO	77 (→ 1358), ... , 82 (→ 1360)
477659	VOLVO	92-47022	VOLVO	77 (→ 1358), ... , 82 (→ 1360)
477792	VOLVO	81-47106	VOLVO	66 (→ 1355), ... , 81 (→ 1360)
477877	VOLVO	81-47106	VOLVO	66 (→ 1355), ... , 81 (→ 1360)
4784888	FIAT	17075	FIAT	135 (→ 255), 136 (→ 256)
4784889	FIAT	17076	FIAT	135 (→ 255), 136 (→ 256)
478750	VOLVO	20100412200	VOLVO	121 (→ 1384), ... , 135 (→ 1390)
4789890	FIAT	17076	FIAT	135 (→ 255), 136 (→ 256)
4790317	VOLVO	20100412001	VOLVO	103 (→ 1371), ... , 135 (→ 1391)
479204	VOLVO	105-35037	VOLVO	103 (→ 1371), ... , 108 (→ 1375)
479205	VOLVO	105-35037	VOLVO	103 (→ 1371), ... , 108 (→ 1375)
479261	VOLVO	48324	VOLVO	109 (→ 1376), 111 (→ 1377)
479450	VOLVO	20100410200	VOLVO	106 (→ 1374), 111 (→ 1377)
479610	VOLVO	20100410200	VOLVO	106 (→ 1374), 111 (→ 1377)
4796108	VOLVO	20100410200	VOLVO	106 (→ 1374), 111 (→ 1377)
4796207	VOLVO	20100412200	VOLVO	121 (→ 1384), ... , 135 (→ 1390)
4798633	VOLVO	20100412001	VOLVO	103 (→ 1371), ... , 135 (→ 1391)
4803805	FIAT	17075	FIAT	135 (→ 255), 136 (→ 256)
4806717	FIAT	17076	FIAT	135 (→ 255), 136 (→ 256)
4806718	FIAT	17076	FIAT	135 (→ 255), 136 (→ 256)
4813760	FIAT	17080	FIAT	118 (→ 249)
4821709	FIAT	50 009 050	FIAT	139 (→ 257)
4821710	FIAT	50 009 050	FIAT	139 (→ 257)
4824416	FIAT	17075	FIAT	135 (→ 255), 136 (→ 256)
4860107	FIAT	171018	FIAT	138 (→ 256)
4C1Q 6A270 AC	FORD	50 007 101	FORD	121 (→ 334), ... , 124 (→ 335)
4C1Q 6A270 BB	FORD	50 007 095	FORD	90 (→ 319), ... , 106 (→ 326)
4C1Q 6A273 AB	FORD	50 007 102	FORD	121 (→ 334), ... , 124 (→ 335)
4C1Q 6A273 BB	FORD	50 007 085	FORD	90 (→ 319), ... , 106 (→ 326)
4C1Q-6A270-AB	FORD	50 007 101	FORD	121 (→ 334), ... , 124 (→ 335)
4S7Q6C501AA	FORD	50 006 432	FORD	12 (→ 296), ... , 25 (→ 300)
5 518 3592	FIAT	171036	FIAT	42 (→ 226), ... , 94 (→ 241)
5 519 2067	FIAT	171036	FIAT	42 (→ 226), ... , 94 (→ 241)
5 519 4219	FIAT	171117	FIAT	19 (→ 222), ... , 22 (→ 222)
5 519 6738	FIAT	171043	FIAT	89 (→ 239), ... , 94 (→ 241)
5 520 0334	FIAT	171117	FIAT	19 (→ 222), ... , 22 (→ 222)
5 520 0335	FIAT	171118	FIAT	19 (→ 222), ... , 22 (→ 222)
5 520 0422	FIAT	171118	FIAT	19 (→ 222), ... , 22 (→ 222)
5 521 9143	FIAT	171117	FIAT	19 (→ 222), ... , 22 (→ 222)
5 521 9144	FIAT	171118	FIAT	19 (→ 222), ... , 22 (→ 222)
5 535 5572	FIAT	291118	FIAT	43 (→ 226)
5 555 7741	FIAT	291117	FIAT	43 (→ 226)
5 942 728	FIAT	17055	FIAT	14 (→ 221), 16 (→ 221)
50 01 001 245	RENAULT	RK-8	RENAULT	98 (→ 1010), ... , 107 (→ 1013)
50 01 001 581	RENAULT	81-17114	RENAULT	98 (→ 1010), ... , 107 (→ 1013)
50 10 248 411	RENAULT	81-59004	RENAULT	125 (→ 1018), 128 (→ 1020)
500354682	FIAT	171070	FIAT	140 (→ 257), 141 (→ 257)
500354685	FIAT	171070	FIAT	140 (→ 257), 141 (→ 257)
500355776	FIAT	171072	FIAT	143 (→ 258)
500355778	FIAT	171111	FIAT	144 (→ 258)
500355779	FIAT	171109	FIAT	143 (→ 258)
500362855	FIAT	171113	FIAT	99 (→ 242), 100 (→ 242)
500362856	FIAT	171114	FIAT	99 (→ 242), 100 (→ 242)
500391436	FIAT	81-17131	FIAT	140 (→ 257), 141 (→ 257)
500391440	FIAT	81-17130	FIAT	140 (→ 257), 141 (→ 257)
504042363	FIAT	171108	FIAT	140 (→ 257), 141 (→ 257)
504042365	FIAT	171070	FIAT	140 (→ 257), 141 (→ 257)
504042366	FIAT	171072	FIAT	143 (→ 258)
504042367	FIAT	171109	FIAT	143 (→ 258)
504069199	FIAT	171113	FIAT	99 (→ 242), 100 (→ 242)
504069200	FIAT	171120	FIAT	98 (→ 242), ... , 118 (→ 249)
504072531	FIAT	171115	FIAT	120 (→ 250), ... , 125 (→ 251)
504080352	FIAT	171112	FIAT	144 (→ 258)
504080984	FIAT	50 007 048	FIAT	120 (→ 250), ... , 123 (→ 251)

# ALPHANUMERICAL LIST

Reference	Item No.	Pos (→  )		
504080985	FIAT	50 007 047	FIAT	120 (→ 250), ... , 123 (→ 251)
504081062	FIAT	171116	FIAT	120 (→ 250), ... , 125 (→ 251)
504238926	FIAT	171115	FIAT	120 (→ 250), ... , 125 (→ 251)
504238928	FIAT	171116	FIAT	120 (→ 250), ... , 125 (→ 251)
504246093	FIAT	50 007 047	FIAT	120 (→ 250), ... , 123 (→ 251)
504246094	FIAT	50 007 048	FIAT	120 (→ 250), ... , 123 (→ 251)
504378070	FIAT	171114	FIAT	99 (→ 242), 100 (→ 242)
504380370	FIAT	50 007 629	FIAT	100 (→ 242), ... , 125 (→ 251)
5155405	FORD	181109	FORD	115 (→ 333)
5252049	FORD	50 007 779	FORD	94 (→ 321)
55185028	FIAT	171125	FIAT	23 (→ 223)
55185080	FIAT	171126	FIAT	23 (→ 223)
55192156	FIAT	291109	FIAT	88 (→ 239)
55193126	FIAT	171046	FIAT	51 (→ 228), 52 (→ 229)
55193839	FIAT	50 007 620	FIAT	21 (→ 222), 23 (→ 223)
55195535	FIAT	291113	FIAT	34 (→ 224), ... , 69 (→ 234)
55195680	FIAT	291111	FIAT	7 (→ 219), ... , 10 (→ 220)
55195803	FIAT	50 007 685	FIAT	20 (→ 222)
55200333	FIAT	50 007 612	FIAT	55 (→ 230)
55202556	FIAT	291113	FIAT	34 (→ 224), ... , 69 (→ 234)
55202557	FIAT	291115	FIAT	34 (→ 224), ... , 69 (→ 234)
55202630	FIAT	171062	FIAT	51 (→ 228), 52 (→ 229)
55202685	FIAT	291112	FIAT	7 (→ 219), ... , 10 (→ 220)
55205183	FIAT	291116	FIAT	33 (→ 224), ... , 69 (→ 234)
55206425	FIAT	50 007 777	FIAT	54 (→ 229), 55 (→ 230)
55206431	FIAT	291114	FIAT	34 (→ 224), ... , 69 (→ 234)
55206897	FIAT	50 007 799	FIAT	10 (→ 220), ... , 12 (→ 220)
55206898	FIAT	50 007 800	FIAT	10 (→ 220), ... , 12 (→ 220)
55208213	FIAT	291112	FIAT	7 (→ 219), ... , 10 (→ 220)
55219965	FIAT	291111	FIAT	7 (→ 219), ... , 10 (→ 220)
55225891	FIAT	171124	FIAT	33 (→ 224), 34 (→ 224)
5942728	LANCIA	17055	LANCIA	6 (→ 353)
5950297	FIAT	50 007 567	FIAT	61 (→ 232)
60 01 548 029	RENAULT	511018	RENAULT	16 (→ 981), 32 (→ 988)
60 01 548 030	RENAULT	511017	RENAULT	16 (→ 981), 32 (→ 988)
60 05 024 961	RENAULT	20100522660	RENAULT	117 (→ 1016), ... , 119 (→ 1016)
60 105 343	FIAT	50 004 282	FIAT	119 (→ 250), ... , 133 (→ 254)
6000616566	FIAT	50 007 711	FIAT	39 (→ 226)
6062844	FORD	50 006 260	FORD	38 (→ 304), ... , 137 (→ 342)
6062845	FORD	50 007 624	FORD	39 (→ 304), ... , 137 (→ 342)
608 11 086	FIAT	81-17122	FIAT	42 (→ 226), ... , 94 (→ 241)
608 11 089	FIAT	81-17123	FIAT	42 (→ 226), ... , 94 (→ 241)
60811086	LANCIA	81-17122	LANCIA	16 (→ 355), ... , 46 (→ 363)
6129778	FORD	50 006 477	FORD	19 (→ 298), ... , 54 (→ 309)
6129780	FORD	50 006 477	FORD	19 (→ 298), ... , 54 (→ 309)
61315973	FIAT	171121	FIAT	142 (→ 258)
61316814	FIAT	17165	FIAT	142 (→ 258)
61320722	FIAT	17165	FIAT	142 (→ 258)
61321255	FIAT	171121	FIAT	142 (→ 258)
6172845	FORD	18345	FORD	69 (→ 312), ... , 72 (→ 314)
6172848	FORD	18345	FORD	69 (→ 312), ... , 72 (→ 314)
6172851	FORD	105-35529	FORD	69 (→ 312), 71 (→ 313)
6172854	FORD	18345	FORD	69 (→ 312), ... , 72 (→ 314)
6172956	FORD	81-17100	FORD	99 (→ 323), ... , 136 (→ 341)
6265699	LANCIA	81-1755	LANCIA	1 (→ 352), ... , 47 (→ 363)
6640542	FORD	18391	FORD	58 (→ 310), ... , 102 (→ 324)
6781621	FORD	105-35529	FORD	69 (→ 312), 71 (→ 313)
6804674	FORD	50 007 597	FORD	28 (→ 301), ... , 57 (→ 310)
6945586	FORD	50 007 597	FORD	28 (→ 301), ... , 57 (→ 310)
6C1G 6507 AA	FORD	181108	FORD	115 (→ 333)
6C1Q-6K551-BA	FORD	50 007 652	FORD	107 (→ 327), ... , 127 (→ 338)
6C1Q6A270AD	FORD	50 007 050	FORD	107 (→ 327)
6C1Q6A273AC	FORD	50 007 051	FORD	107 (→ 327)
6C1Q6A273BB	FORD	50 007 028	FORD	126 (→ 337), 127 (→ 338)
6G9Q 6564 BA	FORD	50 007 848	FORD	90 (→ 319), ... , 96 (→ 322)

Reference		Item No.		Pos (→  )
6G9Q-6500-AA	FORD	50 006 494	FORD	90 (→ 319), ... , 98 (→ 323)
6M5G 6505 AA	FORD	471209	FORD	67 (→ 312), ... , 76 (→ 315)
6M5G 6507 AA	FORD	471206	FORD	67 (→ 312), ... , 76 (→ 315)
7 174 4388	FIAT	291118	FIAT	43 (→ 226)
7 301 820	FIAT	171120	FIAT	98 (→ 242), ... , 118 (→ 249)
7 301 821	FIAT	17063	FIAT	104 (→ 244), ... , 113 (→ 247)
7 588 577	FIAT	17061	FIAT	62 (→ 232)
7 616 998	FIAT	81-17112	FIAT	72 (→ 235), 73 (→ 235)
7 617 500	FIAT	17089	FIAT	92 (→ 240)
7 666 227	FIAT	17055	FIAT	14 (→ 221), 16 (→ 221)
7 735 898	FIAT	171005	FIAT	46 (→ 227), 49 (→ 228)
7 735 899	FIAT	171003	FIAT	46 (→ 227), 49 (→ 228)
7 756 897	LANCIA	81-17122	LANCIA	16 (→ 355), ... , 46 (→ 363)
7 757 052	FIAT	81-17122	FIAT	42 (→ 226), ... , 94 (→ 241)
7 766 565	FIAT	171004	FIAT	45 (→ 227), 49 (→ 228)
7 779 402	FIAT	81-17123	FIAT	42 (→ 226), ... , 94 (→ 241)
7 783 225	FIAT	171014	FIAT	50 (→ 228)
70HM 6505 DE	FORD	7885	FORD	78 (→ 315), ... , 137 (→ 342)
70HM 6507 DD	FORD	7837	FORD	78 (→ 315), ... , 137 (→ 342)
71739265	FIAT	50 007 658	FIAT	88 (→ 239)
71739277	FIAT	291109	FIAT	88 (→ 239)
71739320	FIAT	291110	FIAT	88 (→ 239)
71739686	FIAT	291110	FIAT	88 (→ 239)
71739771	FIAT	81-4219	FIAT	43 (→ 226)
71777464	FIAT	50 007 658	FIAT	88 (→ 239)
7314594	FORD	105-35514	FORD	27 (→ 301), ... , 54 (→ 309)
7314599	FORD	105-35514	FORD	27 (→ 301), ... , 54 (→ 309)
73501138	FIAT	50 006 484	FIAT	7 (→ 219), ... , 12 (→ 221)
73501374	FIAT	50 007 105	FIAT	54 (→ 229), 55 (→ 230)
73503122	FIAT	50 006 422	FIAT	18 (→ 222), ... , 95 (→ 241)
74 03 165 303	RENAULT	81-47114	RENAULT	122 (→ 1017), ... , 127 (→ 1019)
74 03 165 303	RENAULT	81-47119	RENAULT	122 (→ 1017), ... , 127 (→ 1019)
74 20 746 807	RENAULT	20100411001	RENAULT	122 (→ 1017), 123 (→ 1018)
74 20 904 074	RENAULT	81-47114	RENAULT	122 (→ 1017), ... , 127 (→ 1019)
74 20 904 074	RENAULT	81-47119	RENAULT	122 (→ 1017), ... , 127 (→ 1019)
74 20 905 400	RENAULT	81-47114	RENAULT	122 (→ 1017), ... , 127 (→ 1019)
74 21 110 437	RENAULT	20100413005	RENAULT	127 (→ 1019)
74 21 110 842	RENAULT	20100413001	RENAULT	126 (→ 1019), 127 (→ 1019)
74 21 189 194	RENAULT	20100411002	RENAULT	123 (→ 1018)
74 22 584 592	RENAULT	20100411002	RENAULT	123 (→ 1018)
74 22 584 593	RENAULT	20100411001	RENAULT	122 (→ 1017), 123 (→ 1018)
74 38 610 007	RENAULT	47145	RENAULT	72 (→ 1002)
74 38 610 008	RENAULT	47130	RENAULT	72 (→ 1002)
7439207830	RENAULT	50 007 605	RENAULT	72 (→ 1002)
7565472	LANCIA	81-17129	LANCIA	22 (→ 357), ... , 25 (→ 358)
7588577	LANCIA	17061	LANCIA	28 (→ 358)
7666227	LANCIA	17055	LANCIA	6 (→ 353)
77 00 100 939	RENAULT	50 006 427	RENAULT	41 (→ 992), ... , 64 (→ 999)
77 00 102 349	RENAULT	50 007 540	RENAULT	18 (→ 982), ... , 55 (→ 997)
77 00 102 351	RENAULT	50 007 541	RENAULT	18 (→ 982), ... , 55 (→ 997)
77 00 102 353	RENAULT	50 007 542	RENAULT	18 (→ 982), ... , 55 (→ 997)
77 00 102 355	RENAULT	50 007 543	RENAULT	18 (→ 982), ... , 55 (→ 997)
77 00 102 357	RENAULT	50 007 544	RENAULT	18 (→ 982), ... , 55 (→ 997)
77 00 102 359	RENAULT	50 007 545	RENAULT	18 (→ 982), ... , 55 (→ 997)
77 00 102 361	RENAULT	50 007 546	RENAULT	18 (→ 982), ... , 55 (→ 997)
77 00 102 363	RENAULT	50 007 547	RENAULT	18 (→ 982), ... , 55 (→ 997)
77 00 103 628	RENAULT	50 007 548	RENAULT	18 (→ 982), ... , 55 (→ 997)
77 00 103 630	RENAULT	50 007 549	RENAULT	18 (→ 982), ... , 55 (→ 997)
77 00 106 678	RENAULT	50 006 198	RENAULT	41 (→ 991), ... , 54 (→ 997)
77 00 107 555	RENAULT	50 006 437	RENAULT	33 (→ 988), ... , 69 (→ 1001)
77 00 107 556	RENAULT	50 006 486	RENAULT	33 (→ 988), ... , 67 (→ 1000)
77 00 109 151	RENAULT	81-5136	RENAULT	3 (→ 976), ... , 71 (→ 1002)
77 00 110 386	RENAULT	511013	RENAULT	46 (→ 993), ... , 55 (→ 997)
77 00 110 387	RENAULT	511013	RENAULT	46 (→ 993), ... , 55 (→ 997)
77 00 110 388	RENAULT	511014	RENAULT	46 (→ 993), ... , 55 (→ 997)

# ALPHANUMERICAL LIST

Reference	Item No.	Pos (→  )		
77 00 110 389	RENAULT	511014	RENAULT	46 (→ 993), ... , 55 (→ 997)
77 00 110 675	RENAULT	50 006 316	RENAULT	33 (→ 988), 38 (→ 991)
77 00 110 676	RENAULT	50 006 315	RENAULT	33 (→ 988), 38 (→ 991)
77 00 113 894	RENAULT	50 006 316	RENAULT	33 (→ 988), 38 (→ 991)
77 00 113 895	RENAULT	50 006 315	RENAULT	33 (→ 988), 38 (→ 991)
77 00 273 371	RENAULT	511017	RENAULT	16 (→ 981), 32 (→ 988)
77 00 273 373	RENAULT	511017	RENAULT	16 (→ 981), 32 (→ 988)
77 00 663 545	RENAULT	515319	RENAULT	89 (→ 1007)
77 00 692 312	RENAULT	515319	RENAULT	89 (→ 1007)
77 00 725 145	RENAULT	KK-7H	RENAULT	1 (→ 976), ... , 70 (→ 1001)
77 00 743 529	RENAULT	81-5131	RENAULT	58 (→ 998), 59 (→ 998)
77 00 853 390	RENAULT	511017	RENAULT	16 (→ 981), 32 (→ 988)
77 00 856 805	RENAULT	50 006 429	RENAULT	90 (→ 1008), 92 (→ 1008)
77 00 858 606	RENAULT	50 006 431	RENAULT	90 (→ 1008), ... , 93 (→ 1009)
77 00 859 086	RENAULT	81-5135	RENAULT	46 (→ 993), ... , 55 (→ 997)
77 00 865 550	RENAULT	511011	RENAULT	62 (→ 999), 70 (→ 1001)
77 00 865 551	RENAULT	511012	RENAULT	62 (→ 999), 70 (→ 1001)
77 00 865 832	RENAULT	511018	RENAULT	16 (→ 981), 32 (→ 988)
77 00 865 934	RENAULT	511018	RENAULT	16 (→ 981), 32 (→ 988)
77 00 869 325	RENAULT	50 006 188	RENAULT	91 (→ 1008), ... , 93 (→ 1008)
77 00 873 652	RENAULT	LK-5.5H	RENAULT	33 (→ 988), ... , 39 (→ 991)
77 01 030 863	RENAULT	171120	RENAULT	98 (→ 1010), ... , 107 (→ 1013)
77 01 062 311	RENAULT	50 007 711	RENAULT	73 (→ 1002), ... , 84 (→ 1006)
77 01 062 312	RENAULT	50 006 432	RENAULT	73 (→ 1002), ... , 88 (→ 1007)
77 01 460 147	RENAULT	536226	RENAULT	95 (→ 1010), 97 (→ 1010)
77 01 461 338	RENAULT	515319	RENAULT	89 (→ 1007)
77 01 462 678	RENAULT	171120	RENAULT	98 (→ 1010), ... , 107 (→ 1013)
77 01 463 082	RENAULT	517981	RENAULT	56 (→ 998), 57 (→ 998)
77 01 463 603	RENAULT	171120	RENAULT	98 (→ 1010), ... , 107 (→ 1013)
77 01 465 088	RENAULT	511017	RENAULT	16 (→ 981), 32 (→ 988)
77 01 465 090	RENAULT	511018	RENAULT	16 (→ 981), 32 (→ 988)
77 01 466 606	RENAULT	510201	RENAULT	60 (→ 998), 61 (→ 999)
77 01 466 607	RENAULT	510202	RENAULT	60 (→ 998), 61 (→ 999)
77 01 468 419	RENAULT	511018	RENAULT	16 (→ 981), 32 (→ 988)
77 01 469 266	RENAULT	511019	RENAULT	4 (→ 976)
77 01 469 269	RENAULT	511020	RENAULT	4 (→ 976)
77 01 471 279	RENAULT	539011	RENAULT	65 (→ 1000), ... , 71 (→ 1002)
77 01 471 280	RENAULT	539014	RENAULT	65 (→ 1000), ... , 71 (→ 1002)
77 01 471 354	RENAULT	531032	RENAULT	33 (→ 988), ... , 39 (→ 991)
77 01 471 378	RENAULT	531031	RENAULT	33 (→ 988), ... , 39 (→ 991)
77 01 471 379	RENAULT	531032	RENAULT	33 (→ 988), ... , 39 (→ 991)
77 01 471 702	RENAULT	511013	RENAULT	46 (→ 993), ... , 55 (→ 997)
77 01 471 703	RENAULT	511014	RENAULT	46 (→ 993), ... , 55 (→ 997)
77 01 472 124	RENAULT	531031	RENAULT	33 (→ 988), ... , 39 (→ 991)
77 01 472 669	RENAULT	539020	RENAULT	94 (→ 1009), 96 (→ 1010)
77 01 472 670	RENAULT	539021	RENAULT	94 (→ 1009), 96 (→ 1010)
77 01 472 986	RENAULT	539028	RENAULT	3 (→ 976), ... , 6 (→ 977)
77 01 473 004	RENAULT	539029	RENAULT	3 (→ 976), ... , 6 (→ 977)
77 01 473 101	RENAULT	539014	RENAULT	65 (→ 1000), ... , 71 (→ 1002)
77 01 473 183	RENAULT	539017	RENAULT	18 (→ 982), ... , 27 (→ 986)
77 01 473 184	RENAULT	539018	RENAULT	18 (→ 982), ... , 27 (→ 986)
77 01 473 354	RENAULT	531032	RENAULT	33 (→ 988), ... , 39 (→ 991)
77 01 473 355	RENAULT	531032	RENAULT	33 (→ 988), ... , 39 (→ 991)
77 01 474 286	RENAULT	539014	RENAULT	65 (→ 1000), ... , 71 (→ 1002)
77 01 474 287	RENAULT	539011	RENAULT	65 (→ 1000), ... , 71 (→ 1002)
77 01 476 024	RENAULT	511013	RENAULT	46 (→ 993), ... , 55 (→ 997)
77 01 476 025	RENAULT	511014	RENAULT	46 (→ 993), ... , 55 (→ 997)
77 01 476 256	RENAULT	511014	RENAULT	46 (→ 993), ... , 55 (→ 997)
77 01 476 572	RENAULT	539017	RENAULT	18 (→ 982), ... , 27 (→ 986)
77 01 476 573	RENAULT	539018	RENAULT	18 (→ 982), ... , 27 (→ 986)
77 01 476 595	RENAULT	539025	RENAULT	73 (→ 1002), ... , 88 (→ 1007)
77 01 476 596	RENAULT	539024	RENAULT	73 (→ 1002), ... , 88 (→ 1007)
77 01 478 130	RENAULT	539014	RENAULT	65 (→ 1000), ... , 71 (→ 1002)
7700744596	RENAULT	50 007 604	RENAULT	59 (→ 998), 62 (→ 999)
78HM 6250 AA	FORD	50 006 260	FORD	38 (→ 304), ... , 137 (→ 342)

# ALPHANUMERICAL LIST

Reference		Item No.		Pos (→  )
78HM 6250 BA	FORD	50 006 257	FORD	100 (→ 323), ... , 135 (→ 341)
78HM6564AA	FORD	50 007 624	FORD	39 (→ 304), ... , 137 (→ 342)
79 00 000 681	RENAULT	538930	RENAULT	95 (→ 1010), 97 (→ 1010)
7902101354	LANCIA	81-5609	LANCIA	49 (→ 364), 50 (→ 364)
7902101355	LANCIA	81-5609	LANCIA	49 (→ 364), 50 (→ 364)
8 830 045	FIAT	17072	FIAT	139 (→ 257)
8131798	VOLVO	92-47039	VOLVO	178 (→ 1417)
8148069	VOLVO	48309	VOLVO	94 (→ 1366), ... , 101 (→ 1370)
8148524	VOLVO	20100412004	VOLVO	136 (→ 1391), 141 (→ 1395)
8148574	VOLVO	48227	VOLVO	136 (→ 1391), ... , 148 (→ 1399)
8170995	VOLVO	RK-10H	VOLVO	177 (→ 1416), ... , 182 (→ 1418)
81937278	VOLVO	20100412200	VOLVO	121 (→ 1384), ... , 135 (→ 1390)
8194223	VOLVO	48324	VOLVO	109 (→ 1376), 111 (→ 1377)
8194224	VOLVO	48151	VOLVO	103 (→ 1371), ... , 111 (→ 1377)
8194480	VOLVO	20100410200	VOLVO	106 (→ 1374), 111 (→ 1377)
81SM 6251 KE	FORD	50 006 259	FORD	17 (→ 298), ... , 62 (→ 311)
81SM 6510 LC	FORD	81-18104	FORD	16 (→ 297), ... , 114 (→ 332)
82 00 019 181	RENAULT	50 007 118	RENAULT	94 (→ 1009), 96 (→ 1010)
82 00 019 181	RENAULT	50 007 126	RENAULT	94 (→ 1009), 96 (→ 1010)
82 00 019 183	RENAULT	50 007 123	RENAULT	94 (→ 1009), 96 (→ 1010)
82 00 019 183	RENAULT	50 007 124	RENAULT	94 (→ 1009), 96 (→ 1010)
82 00 084 742	RENAULT	50 006 332	RENAULT	46 (→ 993), ... , 49 (→ 995)
82 00 089 894	RENAULT	50 006 314	RENAULT	18 (→ 982), ... , 26 (→ 986)
82 00 100 527	RENAULT	50 006 316	RENAULT	33 (→ 988), 38 (→ 991)
82 00 100 528	RENAULT	50 006 315	RENAULT	33 (→ 988), 38 (→ 991)
82 00 115 605	RENAULT	50 006 486	RENAULT	33 (→ 988), ... , 67 (→ 1000)
82 00 216 090	RENAULT	50 007 776	RENAULT	36 (→ 990)
82 00 235 677	RENAULT	50 007 774	RENAULT	36 (→ 990)
82 00 343 407	RENAULT	539028	RENAULT	3 (→ 976), ... , 6 (→ 977)
82 00 343 412	RENAULT	539029	RENAULT	3 (→ 976), ... , 6 (→ 977)
82 00 381 578	RENAULT	50 007 854	RENAULT	77 (→ 1004), 82 (→ 1005)
82 00 456 103	RENAULT	50 007 709	RENAULT	73 (→ 1002), ... , 87 (→ 1007)
82 00 562 080	RENAULT	81-5332	RENAULT	94 (→ 1009), 96 (→ 1010)
82 00 619 361	RENAULT	50 007 710	RENAULT	73 (→ 1002), ... , 87 (→ 1007)
82 00 679 572	RENAULT	50 007 076	RENAULT	24 (→ 985), ... , 27 (→ 987)
82 00 718 120	RENAULT	50 007 017	RENAULT	18 (→ 982), ... , 26 (→ 986)
82 00 825 144	RENAULT	50 007 854	RENAULT	77 (→ 1004), 82 (→ 1005)
82 00 827 912	RENAULT	50 007 710	RENAULT	73 (→ 1002), ... , 87 (→ 1007)
82 00 827 922	RENAULT	50 007 709	RENAULT	73 (→ 1002), ... , 87 (→ 1007)
82 00 828 299	RENAULT	511013	RENAULT	46 (→ 993), ... , 55 (→ 997)
82 00 872 426	RENAULT	511014	RENAULT	46 (→ 993), ... , 55 (→ 997)
82 00 978 873	RENAULT	50 007 076	RENAULT	24 (→ 985), ... , 27 (→ 987)
82 01 004 849	RENAULT	50 007 076	RENAULT	24 (→ 985), ... , 27 (→ 987)
82 01 033 581	RENAULT	50 007 076	RENAULT	24 (→ 985), ... , 27 (→ 987)
839 12598	FORD	181101	FORD	155 (→ 345)
83EM 6507 AA	FORD	536766	FORD	143 (→ 343)
842080	VOLVO	48302	VOLVO	71 (→ 1356), 72 (→ 1357)
842080-4	VOLVO	48302	VOLVO	71 (→ 1356), 72 (→ 1357)
8420816	VOLVO	KK-8H	VOLVO	8 (→ 1338), ... , 91 (→ 1364)
8420816-4	VOLVO	KK-8H	VOLVO	8 (→ 1338), ... , 91 (→ 1364)
855926	VOLVO	510201	VOLVO	31 (→ 1344)
855927	VOLVO	510202	VOLVO	31 (→ 1344)
8631650	VOLVO	471204	VOLVO	24 (→ 1343), ... , 26 (→ 1343)
8631651	VOLVO	471205	VOLVO	24 (→ 1343), ... , 26 (→ 1343)
863702	VOLVO	48256	VOLVO	173 (→ 1414), 175 (→ 1415)
8653744	VOLVO	181105	VOLVO	45 (→ 1348)
8653745	VOLVO	181104	VOLVO	45 (→ 1348)
8670047	VOLVO	50 006 414	VOLVO	24 (→ 1343), ... , 45 (→ 1348)
8694780	VOLVO	181111	VOLVO	42 (→ 1348)
8694781	VOLVO	181110	VOLVO	42 (→ 1348)
87802256	FORD	105-35646	FORD	156 (→ 345)
87802258	FORD	105-35647	FORD	156 (→ 345)
8824754	FIAT	50 009 050	FIAT	139 (→ 257)
89FF 6505 AA	FORD	18375	FORD	69 (→ 312), ... , 72 (→ 314)
89FF 6505 FA	FORD	18345	FORD	69 (→ 312), ... , 72 (→ 314)



# ALPHANUMERICAL LIST

Reference	Item No.	Pos (→  )
89FF 6507 AA FORD	18374	FORD 70 (→ 313), 72 (→ 314)
9 613 7362 80 FIAT	537450	FIAT 66 (→ 233), 67 (→ 233)
9 629 8611 80 FIAT	533033	FIAT 87 (→ 239)
9 630 5973 80 FIAT	531005	FIAT 66 (→ 233)
9186565 VOLVO	39423	VOLVO 23 (→ 1342)
9186566 VOLVO	331142	VOLVO 23 (→ 1342)
9207830 VOLVO	50 007 605	VOLVO 16 (→ 1340), ... , 37 (→ 1346)
9207874 VOLVO	47145	VOLVO 16 (→ 1340), ... , 40 (→ 1347)
9207880 VOLVO	47130	VOLVO 16 (→ 1340), ... , 40 (→ 1347)
9207977 VOLVO	47130	VOLVO 16 (→ 1340), ... , 40 (→ 1347)
928M 6505 C2A FORD	105-35514	FORD 27 (→ 301), ... , 54 (→ 309)
928M 6505 D2A FORD	18391	FORD 58 (→ 310), ... , 102 (→ 324)
928M 6507 F2A FORD	105-35551	FORD 57 (→ 310), ... , 85 (→ 317)
9350100380 FIAT	50 006 428	FIAT 87 (→ 239)
9350100480 FIAT	50 006 428	FIAT 87 (→ 239)
938M-6500A-1D FORD	50 007 597	FORD 28 (→ 301), ... , 57 (→ 310)
938M-6500A-1E FORD	50 007 597	FORD 28 (→ 301), ... , 57 (→ 310)
938M-6500A-2E FORD	50 007 597	FORD 28 (→ 301), ... , 57 (→ 310)
938M-6500A-2F FORD	50 007 597	FORD 28 (→ 301), ... , 57 (→ 310)
938M6500A1D FORD	50 007 597	FORD 28 (→ 301), ... , 57 (→ 310)
93FF 6507 AA FORD	105-35529	FORD 69 (→ 312), 71 (→ 313)
93FF 6507 AF FORD	105-35529	FORD 69 (→ 312), 71 (→ 313)
9454607 VOLVO	471206	VOLVO 20 (→ 1341), ... , 41 (→ 1348)
9454608 VOLVO	471207	VOLVO 20 (→ 1341), ... , 41 (→ 1348)
9454609 VOLVO	471209	VOLVO 20 (→ 1341), ... , 41 (→ 1348)
9454610 VOLVO	471209	VOLVO 20 (→ 1341), ... , 41 (→ 1348)
9464396380 FIAT	50 006 432	FIAT 54 (→ 229), ... , 79 (→ 237)
9471463 VOLVO	47130	VOLVO 16 (→ 1340), ... , 40 (→ 1347)
9471466 VOLVO	47130	VOLVO 16 (→ 1340), ... , 40 (→ 1347)
948M 6505 A2A FORD	105-35514	FORD 27 (→ 301), ... , 54 (→ 309)
948M 6505 D2A FORD	105-35552	FORD 57 (→ 310), ... , 85 (→ 317)
9623446280 FIAT	50 006 430	FIAT 76 (→ 236), 79 (→ 237)
9624774280 FIAT	531003	FIAT 78 (→ 236), 79 (→ 237)
9624774580 FIAT	531004	FIAT 78 (→ 236), 79 (→ 237)
9627184380 FIAT	181104	FIAT 75 (→ 235), ... , 81 (→ 237)
9630441380 LANCIA	539022	LANCIA 48 (→ 363)
9632372480 FIAT	50 006 432	FIAT 54 (→ 229), ... , 79 (→ 237)
9634437580 FIAT	181105	FIAT 75 (→ 235), ... , 84 (→ 238)
9638075480 FIAT	50 006 435	FIAT 77 (→ 236), ... , 122 (→ 251)
9640181380 LANCIA	539023	LANCIA 48 (→ 363)
9640296380 FIAT	50 006 430	FIAT 76 (→ 236), 79 (→ 237)
9640840080 FIAT	539010	FIAT 25 (→ 223)
9645024780 FIAT	539009	FIAT 25 (→ 223)
9659189980 FIAT	50 006 494	FIAT 82 (→ 238)
975160 VOLVO	20100416001	VOLVO 173 (→ 1414)
97MM 6507 B2B FORD	105-35541	FORD 31 (→ 302)
98427674 FIAT	50 007 054	FIAT 110 (→ 246), ... , 113 (→ 247)
98429886 FIAT	171019	FIAT 137 (→ 256)
98435622 FIAT	17075	FIAT 135 (→ 255), 136 (→ 256)
98497235 FIAT	171019	FIAT 137 (→ 256)
987 064 FIAT	81-1729	FIAT 6 (→ 218)
98MM 6507 C2B FORD	181009	FORD 40 (→ 304)
99432652 FIAT	17075	FIAT 135 (→ 255), 136 (→ 256)
99432717 FIAT	17076	FIAT 135 (→ 255), 136 (→ 256)
99432718 FIAT	17076	FIAT 135 (→ 255), 136 (→ 256)
99432837 FIAT	171055	FIAT 98 (→ 242), ... , 118 (→ 249)
99438924 FIAT	171018	FIAT 138 (→ 256)
99456803 FIAT	171070	FIAT 140 (→ 257), 141 (→ 257)
9M5Q 6507 AA FORD	181117	FORD 92 (→ 320), ... , 94 (→ 321)
9M5Q 6564 AA FORD	50 007 628	FORD 92 (→ 320), 94 (→ 321)
9M5Q 6576 AA FORD	50 007 627	FORD 92 (→ 320), 94 (→ 321)
9S4E 6505 AB FORD	181109	FORD 115 (→ 333)
9S516500BA FORD	50 006 438	FORD 3 (→ 292)
A 000 012 00 14 MERCEDES-BENZ	81-33100	MERCEDES-BENZ 15 (→ 500)
A 000 053 04 26 MERCEDES-BENZ	LK-1605	MERCEDES-BENZ 315 (→ 663), ... , 475 (→ 824)



# ALPHANUMERICAL LIST

Reference	Item No.	Pos (→  )		
A 000 053 10 26	MERCEDES-BENZ	LK-6H	MERCEDES-BENZ	56 (→ 515), ... , 86 (→ 531)
A 000 053 11 26	MERCEDES-BENZ	MK-6H	MERCEDES-BENZ	6 (→ 498), ... , 116 (→ 541)
A 040 507 08 25	MERCEDES-BENZ	50 006 456	MERCEDES-BENZ	60 (→ 517), ... , 88 (→ 532)
A 102 050 02 01	MERCEDES-BENZ	50 006 212	MERCEDES-BENZ	78 (→ 526), 118 (→ 542)
A 102 050 04 62	MERCEDES-BENZ	81-2635	MERCEDES-BENZ	78 (→ 526), ... , 119 (→ 542)
A 102 050 05 62	MERCEDES-BENZ	81-26148	MERCEDES-BENZ	78 (→ 526), ... , 119 (→ 542)
A 102 050 09 24	MERCEDES-BENZ	81-2631	MERCEDES-BENZ	78 (→ 526), ... , 119 (→ 542)
A 102 050 10 24	MERCEDES-BENZ	81-2632	MERCEDES-BENZ	78 (→ 526), ... , 119 (→ 542)
A 102 050 12 24	MERCEDES-BENZ	81-2634	MERCEDES-BENZ	78 (→ 526), ... , 119 (→ 542)
A 102 050 13 24	MERCEDES-BENZ	81-2635	MERCEDES-BENZ	78 (→ 526), ... , 119 (→ 542)
A 102 050 17 24	MERCEDES-BENZ	81-2631	MERCEDES-BENZ	78 (→ 526), ... , 119 (→ 542)
A 102 050 18 24	MERCEDES-BENZ	81-2634	MERCEDES-BENZ	78 (→ 526), ... , 119 (→ 542)
A 102 050 37 24	MERCEDES-BENZ	81-26109	MERCEDES-BENZ	120 (→ 543)
A 102 050 40 24	MERCEDES-BENZ	81-26106	MERCEDES-BENZ	120 (→ 543)
A 102 050 55 01	MERCEDES-BENZ	50 006 222	MERCEDES-BENZ	79 (→ 527), 119 (→ 542)
A 102 050 67 24	MERCEDES-BENZ	81-26139	MERCEDES-BENZ	121 (→ 543)
A 102 050 83 24	MERCEDES-BENZ	81-26142	MERCEDES-BENZ	121 (→ 543)
A 102 050 89 24	MERCEDES-BENZ	81-26145	MERCEDES-BENZ	78 (→ 526), ... , 119 (→ 542)
A 102 053 00 26	MERCEDES-BENZ	RK-8H	MERCEDES-BENZ	28 (→ 505), ... , 313 (→ 662)
A 102 053 02 26	MERCEDES-BENZ	RK-7	MERCEDES-BENZ	81 (→ 527), ... , 121 (→ 543)
A 102 053 13 01	MERCEDES-BENZ	26160	MERCEDES-BENZ	78 (→ 526), ... , 118 (→ 542)
A 102 053 15 01	MERCEDES-BENZ	26135	MERCEDES-BENZ	78 (→ 526), ... , 119 (→ 542)
A 102 053 16 01	MERCEDES-BENZ	26160	MERCEDES-BENZ	78 (→ 526), ... , 118 (→ 542)
A 102 053 17 01	MERCEDES-BENZ	26135	MERCEDES-BENZ	78 (→ 526), ... , 119 (→ 542)
A 102 053 18 01	MERCEDES-BENZ	26160	MERCEDES-BENZ	78 (→ 526), ... , 118 (→ 542)
A 103 050 00 80	MERCEDES-BENZ	50 006 454	MERCEDES-BENZ	28 (→ 505), ... , 119 (→ 543)
A 103 050 05 27	MERCEDES-BENZ	261113	MERCEDES-BENZ	76 (→ 525)
A 103 050 13 27	MERCEDES-BENZ	261112	MERCEDES-BENZ	28 (→ 504)
A 103 050 17 27	MERCEDES-BENZ	261113	MERCEDES-BENZ	76 (→ 525)
A 103 050 22 24	MERCEDES-BENZ	81-26151	MERCEDES-BENZ	28 (→ 505), 76 (→ 525)
A 103 050 27 24	MERCEDES-BENZ	81-26154	MERCEDES-BENZ	28 (→ 505), 76 (→ 525)
A 103 050 64 01	MERCEDES-BENZ	50 006 223	MERCEDES-BENZ	28 (→ 505), 76 (→ 525)
A 103 053 04 01	MERCEDES-BENZ	26109	MERCEDES-BENZ	76 (→ 525)
A 103 053 13 01	MERCEDES-BENZ	26109	MERCEDES-BENZ	76 (→ 525)
A 103 053 20 01	MERCEDES-BENZ	26109	MERCEDES-BENZ	76 (→ 525)
A 103 053 21 01	MERCEDES-BENZ	26107	MERCEDES-BENZ	28 (→ 504)
A 103 053 23 01	MERCEDES-BENZ	26107	MERCEDES-BENZ	28 (→ 504)
A 104 050 12 25	MERCEDES-BENZ	50 006 421	MERCEDES-BENZ	52 (→ 513), ... , 250 (→ 624)
A 104 050 47 24	MERCEDES-BENZ	81-26166	MERCEDES-BENZ	77 (→ 525), 90 (→ 533)
A 104 050 52 24	MERCEDES-BENZ	81-26163	MERCEDES-BENZ	77 (→ 525), ... , 125 (→ 544)
A 104 050 74 01	MERCEDES-BENZ	50 006 226	MERCEDES-BENZ	77 (→ 525), ... , 104 (→ 538)
A 104 053 08 01	MERCEDES-BENZ	26139	MERCEDES-BENZ	77 (→ 525)
A 104 053 10 01	MERCEDES-BENZ	26139	MERCEDES-BENZ	77 (→ 525)
A 104 053 12 01	MERCEDES-BENZ	26048	MERCEDES-BENZ	77 (→ 525), ... , 250 (→ 624)
A 104 053 14 01	MERCEDES-BENZ	26048	MERCEDES-BENZ	77 (→ 525), ... , 250 (→ 624)
A 108 050 05 24	MERCEDES-BENZ	81-2659	MERCEDES-BENZ	16 (→ 500), ... , 117 (→ 541)
A 108 050 07 24	MERCEDES-BENZ	81-2660	MERCEDES-BENZ	16 (→ 500), ... , 117 (→ 541)
A 110 050 00 27	MERCEDES-BENZ	261108	MERCEDES-BENZ	53 (→ 514), 107 (→ 539)
A 110 050 07 26	MERCEDES-BENZ	2635	MERCEDES-BENZ	53 (→ 514), 54 (→ 514)
A 110 050 26 24	MERCEDES-BENZ	81-2679	MERCEDES-BENZ	53 (→ 514), 54 (→ 514)
A 110 050 41 24	MERCEDES-BENZ	81-2696	MERCEDES-BENZ	54 (→ 514)
A 110 050 54 24	MERCEDES-BENZ	81-2679	MERCEDES-BENZ	53 (→ 514), 54 (→ 514)
A 110 050 58 24	MERCEDES-BENZ	81-26124	MERCEDES-BENZ	54 (→ 514)
A 110 050 65 24	MERCEDES-BENZ	81-26136	MERCEDES-BENZ	53 (→ 514)
A 110 053 05 01	MERCEDES-BENZ	2635	MERCEDES-BENZ	53 (→ 514), 54 (→ 514)
A 110 053 06 01	MERCEDES-BENZ	2635	MERCEDES-BENZ	53 (→ 514), 54 (→ 514)
A 111 050 05 27	MERCEDES-BENZ	261114	MERCEDES-BENZ	77 (→ 525), ... , 105 (→ 538)
A 111 050 12 27	MERCEDES-BENZ	260490	MERCEDES-BENZ	81 (→ 527), ... , 250 (→ 624)
A 111 050 21 01	MERCEDES-BENZ	50 006 376	MERCEDES-BENZ	92 (→ 533), ... , 99 (→ 536)
A 111 050 45 01	MERCEDES-BENZ	50 007 698	MERCEDES-BENZ	96 (→ 535), 101 (→ 537)
A 111 050 47 01	MERCEDES-BENZ	50 007 699	MERCEDES-BENZ	96 (→ 535), ... , 101 (→ 537)
A 111 053 01 01	MERCEDES-BENZ	26208	MERCEDES-BENZ	77 (→ 525), ... , 105 (→ 538)
A 111 053 02 01	MERCEDES-BENZ	26208	MERCEDES-BENZ	77 (→ 525), ... , 105 (→ 538)
A 111 053 10 29	MERCEDES-BENZ	81-26172	MERCEDES-BENZ	10 (→ 499), ... , 250 (→ 624)
A 111 053 11 01	MERCEDES-BENZ	26048	MERCEDES-BENZ	77 (→ 525), ... , 250 (→ 624)

# ALPHANUMERICAL LIST

Reference	Item No.	Pos (→  )		
A 111 053 11 29	MERCEDES-BENZ	81-26173	MERCEDES-BENZ	10 (→ 499), ... , 250 (→ 624)
A 111 053 21 01	MERCEDES-BENZ	26048	MERCEDES-BENZ	77 (→ 525), ... , 250 (→ 624)
A 111 053 23 01	MERCEDES-BENZ	26048	MERCEDES-BENZ	77 (→ 525), ... , 250 (→ 624)
A 111 053 24 01	MERCEDES-BENZ	26048	MERCEDES-BENZ	77 (→ 525), ... , 250 (→ 624)
A 113 050 00 33	MERCEDES-BENZ	50 006 497	MERCEDES-BENZ	47 (→ 512), ... , 127 (→ 545)
A 113 050 00 34	MERCEDES-BENZ	50 006 499	MERCEDES-BENZ	47 (→ 512), ... , 127 (→ 545)
A 113 050 01 27	MERCEDES-BENZ	261031	MERCEDES-BENZ	47 (→ 512)
A 113 050 01 33	MERCEDES-BENZ	50 006 495	MERCEDES-BENZ	47 (→ 512), ... , 127 (→ 545)
A 113 050 02 27	MERCEDES-BENZ	261033	MERCEDES-BENZ	95 (→ 535)
A 113 050 03 27	MERCEDES-BENZ	261035	MERCEDES-BENZ	127 (→ 544)
A 113 050 05 34	MERCEDES-BENZ	50 006 499	MERCEDES-BENZ	47 (→ 512), ... , 127 (→ 545)
A 113 053 00 01	MERCEDES-BENZ	261030	MERCEDES-BENZ	47 (→ 512)
A 113 053 01 01	MERCEDES-BENZ	261032	MERCEDES-BENZ	95 (→ 535)
A 113 053 02 01	MERCEDES-BENZ	261034	MERCEDES-BENZ	127 (→ 544)
A 113 053 03 29	MERCEDES-BENZ	81-26183	MERCEDES-BENZ	47 (→ 512), ... , 127 (→ 545)
A 113 053 05 01	MERCEDES-BENZ	261032	MERCEDES-BENZ	95 (→ 535)
A 113 053 06 01	MERCEDES-BENZ	261034	MERCEDES-BENZ	127 (→ 544)
A 115 050 00 27	MERCEDES-BENZ	261106	MERCEDES-BENZ	16 (→ 500), ... , 117 (→ 541)
A 115 050 01 27	MERCEDES-BENZ	261106	MERCEDES-BENZ	16 (→ 500), ... , 117 (→ 541)
A 115 050 02 26	MERCEDES-BENZ	26017	MERCEDES-BENZ	117 (→ 541)
A 115 053 00 26	MERCEDES-BENZ	RK-9H	MERCEDES-BENZ	16 (→ 500), ... , 318 (→ 665)
A 116 050 00 27	MERCEDES-BENZ	261109	MERCEDES-BENZ	66 (→ 520), 108 (→ 539)
A 116 050 01 26	MERCEDES-BENZ	2639	MERCEDES-BENZ	107 (→ 539), ... , 124 (→ 544)
A 116 050 02 26	MERCEDES-BENZ	2639	MERCEDES-BENZ	107 (→ 539), ... , 124 (→ 544)
A 116 050 04 26	MERCEDES-BENZ	26052	MERCEDES-BENZ	66 (→ 520), 108 (→ 539)
A 116 050 36 24	MERCEDES-BENZ	81-2685	MERCEDES-BENZ	66 (→ 520), ... , 122 (→ 543)
A 116 050 41 24	MERCEDES-BENZ	81-2688	MERCEDES-BENZ	107 (→ 539)
A 116 050 47 24	MERCEDES-BENZ	81-26118	MERCEDES-BENZ	66 (→ 520), ... , 124 (→ 544)
A 116 050 49 24	MERCEDES-BENZ	81-26119	MERCEDES-BENZ	66 (→ 520), ... , 124 (→ 544)
A 116 050 53 24	MERCEDES-BENZ	81-26121	MERCEDES-BENZ	66 (→ 520), ... , 124 (→ 544)
A 116 050 55 24	MERCEDES-BENZ	81-26122	MERCEDES-BENZ	66 (→ 520), ... , 124 (→ 544)
A 117 050 00 27	MERCEDES-BENZ	261111	MERCEDES-BENZ	53 (→ 514), ... , 124 (→ 544)
A 117 050 01 26	MERCEDES-BENZ	26112	MERCEDES-BENZ	122 (→ 543), ... , 124 (→ 544)
A 117 050 01 27	MERCEDES-BENZ	261111	MERCEDES-BENZ	53 (→ 514), ... , 124 (→ 544)
A 117 051 08 01	MERCEDES-BENZ	50 006 280	MERCEDES-BENZ	109 (→ 540), 123 (→ 543)
A 117 051 09 01	MERCEDES-BENZ	50 006 281	MERCEDES-BENZ	109 (→ 540), 123 (→ 543)
A 121 050 02 24	MERCEDES-BENZ	81-2640	MERCEDES-BENZ	9 (→ 499), ... , 51 (→ 513)
A 121 050 06 24	MERCEDES-BENZ	81-2629	MERCEDES-BENZ	9 (→ 499), ... , 51 (→ 513)
A 121 050 16 24	MERCEDES-BENZ	81-2628	MERCEDES-BENZ	9 (→ 499), ... , 51 (→ 513)
A 121 050 21 24	MERCEDES-BENZ	81-2630	MERCEDES-BENZ	9 (→ 499), ... , 51 (→ 513)
A 121 050 22 24	MERCEDES-BENZ	81-2639	MERCEDES-BENZ	9 (→ 499), ... , 51 (→ 513)
A 121 053 00 01	MERCEDES-BENZ	2675	MERCEDES-BENZ	50 (→ 513), 51 (→ 513)
A 121 053 04 01	MERCEDES-BENZ	2620	MERCEDES-BENZ	58 (→ 515)
A 121 053 15 05	MERCEDES-BENZ	261121	MERCEDES-BENZ	50 (→ 513), 51 (→ 513)
A 123 053 00 01	MERCEDES-BENZ	2619	MERCEDES-BENZ	16 (→ 500), ... , 57 (→ 515)
A 123 053 01 01	MERCEDES-BENZ	2619	MERCEDES-BENZ	16 (→ 500), ... , 57 (→ 515)
A 127 050 11 24	MERCEDES-BENZ	81-2652	MERCEDES-BENZ	19 (→ 501)
A 129 053 00 05	MERCEDES-BENZ	261106	MERCEDES-BENZ	16 (→ 500), ... , 117 (→ 541)
A 129 053 01 05	MERCEDES-BENZ	261106	MERCEDES-BENZ	16 (→ 500), ... , 117 (→ 541)
A 130 050 01 24	MERCEDES-BENZ	81-2667	MERCEDES-BENZ	16 (→ 500), ... , 117 (→ 541)
A 130 050 02 24	MERCEDES-BENZ	81-2668	MERCEDES-BENZ	16 (→ 500), ... , 117 (→ 541)
A 130 053 01 05	MERCEDES-BENZ	261106	MERCEDES-BENZ	16 (→ 500), ... , 117 (→ 541)
A 137 053 02 30	MERCEDES-BENZ	81-26184	MERCEDES-BENZ	21 (→ 502), ... , 23 (→ 503)
A 160 050 01 80	MERCEDES-BENZ	50 006 432	MERCEDES-BENZ	17 (→ 501), ... , 237 (→ 615)
A 166 050 03 27	MERCEDES-BENZ	261037	MERCEDES-BENZ	10 (→ 499), 11 (→ 499)
A 166 050 04 27	MERCEDES-BENZ	261039	MERCEDES-BENZ	48 (→ 513)
A 166 050 06 01	MERCEDES-BENZ	50 007 590	MERCEDES-BENZ	11 (→ 499)
A 166 050 07 01	MERCEDES-BENZ	50 007 591	MERCEDES-BENZ	10 (→ 499)
A 166 053 01 01	MERCEDES-BENZ	261036	MERCEDES-BENZ	10 (→ 499), 11 (→ 499)
A 166 053 02 01	MERCEDES-BENZ	261038	MERCEDES-BENZ	30 (→ 505), 48 (→ 513)
A 180 050 00 24	MERCEDES-BENZ	81-2643	MERCEDES-BENZ	9 (→ 499)
A 180 050 02 24	MERCEDES-BENZ	81-2643	MERCEDES-BENZ	9 (→ 499)
A 180 050 03 24	MERCEDES-BENZ	81-2691	MERCEDES-BENZ	9 (→ 499)
A 180 053 02 01	MERCEDES-BENZ	2666	MERCEDES-BENZ	9 (→ 499), 19 (→ 501)
A 180 053 04 01	MERCEDES-BENZ	2666	MERCEDES-BENZ	9 (→ 499), 19 (→ 501)

# ALPHANUMERICAL LIST

Reference	Item No.	Pos (→  )		
A 180 053 11 05	MERCEDES-BENZ	261119	MERCEDES-BENZ	9 (→ 499), 19 (→ 501)
A 180 053 15 05	MERCEDES-BENZ	261119	MERCEDES-BENZ	9 (→ 499), 19 (→ 501)
A 181 053 00 01	MERCEDES-BENZ	2660	MERCEDES-BENZ	2 (→ 497), ... , 49 (→ 513)
A 200 050 08 00	MERCEDES-BENZ	50 007 816	MERCEDES-BENZ	1 (→ 497)
A 200 054 00 00	MERCEDES-BENZ	50 007 814	MERCEDES-BENZ	1 (→ 497)
A 200 054 01 00	MERCEDES-BENZ	50 007 822	MERCEDES-BENZ	1 (→ 497)
A 200 054 02 00	MERCEDES-BENZ	50 007 823	MERCEDES-BENZ	1 (→ 497)
A 200 054 03 00	MERCEDES-BENZ	50 007 824	MERCEDES-BENZ	1 (→ 497)
A 200 054 04 00	MERCEDES-BENZ	50 007 836	MERCEDES-BENZ	1 (→ 497)
A 200 054 05 00	MERCEDES-BENZ	50 007 838	MERCEDES-BENZ	1 (→ 497)
A 200 054 06 00	MERCEDES-BENZ	50 007 839	MERCEDES-BENZ	1 (→ 497)
A 200 054 07 00	MERCEDES-BENZ	50 007 840	MERCEDES-BENZ	1 (→ 497)
A 200 054 08 00	MERCEDES-BENZ	50 007 841	MERCEDES-BENZ	1 (→ 497)
A 200 054 09 00	MERCEDES-BENZ	50 007 842	MERCEDES-BENZ	1 (→ 497)
A 200 054 10 00	MERCEDES-BENZ	50 007 843	MERCEDES-BENZ	1 (→ 497)
A 200 054 11 00	MERCEDES-BENZ	50 007 844	MERCEDES-BENZ	1 (→ 497)
A 200 054 12 00	MERCEDES-BENZ	50 007 846	MERCEDES-BENZ	1 (→ 497)
A 200 054 13 00	MERCEDES-BENZ	50 007 847	MERCEDES-BENZ	1 (→ 497)
A 200 054 14 00	MERCEDES-BENZ	50 007 825	MERCEDES-BENZ	1 (→ 497)
A 200 054 15 00	MERCEDES-BENZ	50 007 826	MERCEDES-BENZ	1 (→ 497)
A 200 054 16 00	MERCEDES-BENZ	50 007 827	MERCEDES-BENZ	1 (→ 497)
A 200 054 17 00	MERCEDES-BENZ	50 007 828	MERCEDES-BENZ	1 (→ 497)
A 200 054 18 00	MERCEDES-BENZ	50 007 830	MERCEDES-BENZ	1 (→ 497)
A 200 054 19 00	MERCEDES-BENZ	50 007 831	MERCEDES-BENZ	1 (→ 497)
A 200 054 20 00	MERCEDES-BENZ	50 007 832	MERCEDES-BENZ	1 (→ 497)
A 200 054 21 00	MERCEDES-BENZ	50 007 833	MERCEDES-BENZ	1 (→ 497)
A 200 054 22 00	MERCEDES-BENZ	50 007 834	MERCEDES-BENZ	1 (→ 497)
A 200 054 23 00	MERCEDES-BENZ	50 007 835	MERCEDES-BENZ	1 (→ 497)
A 200 054 24 00	MERCEDES-BENZ	50 007 845	MERCEDES-BENZ	1 (→ 497)
A 264 053 01 00	MERCEDES-BENZ	261148	MERCEDES-BENZ	14 (→ 500), ... , 32 (→ 506)
A 264 053 02 00	MERCEDES-BENZ	261154	MERCEDES-BENZ	14 (→ 500), 32 (→ 506)
A 266 050 00 27	MERCEDES-BENZ	261135	MERCEDES-BENZ	30 (→ 505)
A 266 053 01 05	MERCEDES-BENZ	261135	MERCEDES-BENZ	30 (→ 505)
A 270 050 01 00	MERCEDES-BENZ	261149	MERCEDES-BENZ	29 (→ 505), 31 (→ 505)
A 270 050 01 33	MERCEDES-BENZ	50 007 643	MERCEDES-BENZ	31 (→ 506)
A 270 053 00 01	MERCEDES-BENZ	261148	MERCEDES-BENZ	14 (→ 500), ... , 32 (→ 506)
A 271 050 00 27	MERCEDES-BENZ	261123	MERCEDES-BENZ	21 (→ 502), 22 (→ 503)
A 271 050 04 27	MERCEDES-BENZ	261123	MERCEDES-BENZ	21 (→ 502), 22 (→ 503)
A 271 050 06 27	MERCEDES-BENZ	261129	MERCEDES-BENZ	17 (→ 501), ... , 25 (→ 504)
A 271 050 11 27	MERCEDES-BENZ	261143	MERCEDES-BENZ	24 (→ 503)
A 271 051 18 01	MERCEDES-BENZ	50 007 592	MERCEDES-BENZ	17 (→ 501), ... , 25 (→ 504)
A 271 051 21 01	MERCEDES-BENZ	50 007 593	MERCEDES-BENZ	17 (→ 501), ... , 25 (→ 504)
A 271 053 00 01	MERCEDES-BENZ	261122	MERCEDES-BENZ	21 (→ 502), 22 (→ 503)
A 271 053 05 01	MERCEDES-BENZ	261128	MERCEDES-BENZ	17 (→ 501), ... , 25 (→ 504)
A 271 053 06 01	MERCEDES-BENZ	261128	MERCEDES-BENZ	17 (→ 501), ... , 25 (→ 504)
A 271 053 10 01	MERCEDES-BENZ	261142	MERCEDES-BENZ	24 (→ 503)
A 272 050 02 27	MERCEDES-BENZ	261131	MERCEDES-BENZ	26 (→ 504), 67 (→ 520)
A 272 050 06 27	MERCEDES-BENZ	261133	MERCEDES-BENZ	111 (→ 540), 114 (→ 541)
A 272 050 08 27	MERCEDES-BENZ	261133	MERCEDES-BENZ	111 (→ 540), 114 (→ 541)
A 272 050 09 27	MERCEDES-BENZ	261131	MERCEDES-BENZ	26 (→ 504), 67 (→ 520)
A 272 050 16 27	MERCEDES-BENZ	261133	MERCEDES-BENZ	111 (→ 540), 114 (→ 541)
A 272 053 02 01	MERCEDES-BENZ	261130	MERCEDES-BENZ	26 (→ 504), 67 (→ 520)
A 272 053 05 01	MERCEDES-BENZ	261132	MERCEDES-BENZ	111 (→ 540), 114 (→ 541)
A 272 053 06 01	MERCEDES-BENZ	261132	MERCEDES-BENZ	111 (→ 540), 114 (→ 541)
A 272 053 08 01	MERCEDES-BENZ	261130	MERCEDES-BENZ	26 (→ 504), 67 (→ 520)
A 276 050 00 27	MERCEDES-BENZ	261151	MERCEDES-BENZ	113 (→ 540)
A 278 050 01 26	MERCEDES-BENZ	261150	MERCEDES-BENZ	113 (→ 540), ... , 116 (→ 541)
A 290 053 01 05	MERCEDES-BENZ	261106	MERCEDES-BENZ	16 (→ 500), ... , 117 (→ 541)
A 312 053 02 30	MERCEDES-BENZ	81-1609	MERCEDES-BENZ	129 (→ 546), ... , 235 (→ 614)
A 321 053 09 05	MERCEDES-BENZ	16106	MERCEDES-BENZ	128 (→ 545), ... , 236 (→ 615)
A 321 053 12 30	MERCEDES-BENZ	81-1631	MERCEDES-BENZ	133 (→ 549), ... , 180 (→ 581)
A 321 053 13 30	MERCEDES-BENZ	81-1632	MERCEDES-BENZ	133 (→ 549), ... , 180 (→ 581)
A 327 053 03 31	MERCEDES-BENZ	92-16132	MERCEDES-BENZ	321 (→ 666)
A 327 053 03 32	MERCEDES-BENZ	92-16133	MERCEDES-BENZ	321 (→ 666)
A 327 053 04 31	MERCEDES-BENZ	92-16134	MERCEDES-BENZ	321 (→ 666)



# ALPHANUMERICAL LIST

Reference	Item No.	Pos (→  )		
A 327 053 04 32	MERCEDES-BENZ	92-16135	MERCEDES-BENZ	321 (→ 666)
A 327 053 05 31	MERCEDES-BENZ	92-16136	MERCEDES-BENZ	321 (→ 666)
A 327 053 05 32	MERCEDES-BENZ	92-16137	MERCEDES-BENZ	321 (→ 666)
A 327 053 07 01	MERCEDES-BENZ	1659	MERCEDES-BENZ	321 (→ 665)
A 327 053 08 30	MERCEDES-BENZ	81-1638	MERCEDES-BENZ	321 (→ 665)
A 327 053 14 30	MERCEDES-BENZ	81-1639	MERCEDES-BENZ	321 (→ 665)
A 345 053 01 32	MERCEDES-BENZ	92-16110	MERCEDES-BENZ	359 (→ 704), ... , 474 (→ 824)
A 345 053 71 01	MERCEDES-BENZ	1657	MERCEDES-BENZ	359 (→ 704), ... , 474 (→ 824)
A 345 053 71 05	MERCEDES-BENZ	1658	MERCEDES-BENZ	359 (→ 704), ... , 474 (→ 824)
A 345 054 70 01	MERCEDES-BENZ	20100335560	MERCEDES-BENZ	359 (→ 704), ... , 474 (→ 824)
A 346 053 00 01	MERCEDES-BENZ	1657	MERCEDES-BENZ	359 (→ 704), ... , 474 (→ 824)
A 346 053 01 01	MERCEDES-BENZ	1657	MERCEDES-BENZ	359 (→ 704), ... , 474 (→ 824)
A 346 053 01 05	MERCEDES-BENZ	1658	MERCEDES-BENZ	359 (→ 704), ... , 474 (→ 824)
A 346 053 02 05	MERCEDES-BENZ	1658	MERCEDES-BENZ	359 (→ 704), ... , 474 (→ 824)
A 346 053 03 01	MERCEDES-BENZ	1657	MERCEDES-BENZ	359 (→ 704), ... , 474 (→ 824)
A 346 053 05 32	MERCEDES-BENZ	92-16110	MERCEDES-BENZ	359 (→ 704), ... , 474 (→ 824)
A 346 053 06 32	MERCEDES-BENZ	92-16141	MERCEDES-BENZ	363 (→ 707), ... , 474 (→ 824)
A 346 053 07 31	MERCEDES-BENZ	92-16106	MERCEDES-BENZ	359 (→ 704), ... , 474 (→ 824)
A 346 053 08 31	MERCEDES-BENZ	92-16140	MERCEDES-BENZ	359 (→ 704), ... , 473 (→ 823)
A 346 053 09 29	MERCEDES-BENZ	81-1640	MERCEDES-BENZ	359 (→ 704), ... , 474 (→ 824)
A 346 053 11 29	MERCEDES-BENZ	81-1642	MERCEDES-BENZ	359 (→ 704), ... , 474 (→ 824)
A 346 054 02 01	MERCEDES-BENZ	20100335560	MERCEDES-BENZ	359 (→ 704), ... , 474 (→ 824)
A 352 050 00 26	MERCEDES-BENZ	16136	MERCEDES-BENZ	128 (→ 545), ... , 236 (→ 615)
A 352 050 01 26	MERCEDES-BENZ	16136	MERCEDES-BENZ	128 (→ 545), ... , 236 (→ 615)
A 352 050 10 33	MERCEDES-BENZ	20100336602	MERCEDES-BENZ	129 (→ 546), ... , 236 (→ 615)
A 352 050 44 01	MERCEDES-BENZ	20100335200	MERCEDES-BENZ	129 (→ 546), ... , 161 (→ 569)
A 352 050 49 01	MERCEDES-BENZ	20100335201	MERCEDES-BENZ	130 (→ 547), ... , 180 (→ 581)
A 352 050 50 01	MERCEDES-BENZ	20100335202	MERCEDES-BENZ	141 (→ 555), ... , 162 (→ 570)
A 352 053 01 01	MERCEDES-BENZ	16136	MERCEDES-BENZ	128 (→ 545), ... , 236 (→ 615)
A 352 053 12 29	MERCEDES-BENZ	81-1666	MERCEDES-BENZ	126 (→ 544), ... , 181 (→ 582)
A 352 053 15 05	MERCEDES-BENZ	1604	MERCEDES-BENZ	128 (→ 545), ... , 235 (→ 614)
A 352 053 16 30	MERCEDES-BENZ	81-1658	MERCEDES-BENZ	129 (→ 546), ... , 180 (→ 581)
A 352 053 16 31	MERCEDES-BENZ	92-16112	MERCEDES-BENZ	126 (→ 544), ... , 181 (→ 582)
A 352 053 16 32	MERCEDES-BENZ	92-16131	MERCEDES-BENZ	126 (→ 544), ... , 236 (→ 615)
A 352 053 18 30	MERCEDES-BENZ	81-1659	MERCEDES-BENZ	129 (→ 546), ... , 180 (→ 581)
A 352 053 20 30	MERCEDES-BENZ	81-1670	MERCEDES-BENZ	128 (→ 545), ... , 181 (→ 582)
A 352 053 21 32	MERCEDES-BENZ	92-16131	MERCEDES-BENZ	126 (→ 544), ... , 236 (→ 615)
A 352 053 22 29	MERCEDES-BENZ	81-1674	MERCEDES-BENZ	126 (→ 544), ... , 236 (→ 615)
A 352 053 22 31	MERCEDES-BENZ	92-16112	MERCEDES-BENZ	126 (→ 544), ... , 181 (→ 582)
A 352 053 31 31	MERCEDES-BENZ	92-16112	MERCEDES-BENZ	126 (→ 544), ... , 181 (→ 582)
A 352 053 35 31	MERCEDES-BENZ	92-16114	MERCEDES-BENZ	126 (→ 544), ... , 181 (→ 582)
A 352 053 37 30	MERCEDES-BENZ	81-1676	MERCEDES-BENZ	126 (→ 544), ... , 236 (→ 615)
A 352 053 38 31	MERCEDES-BENZ	92-16114	MERCEDES-BENZ	126 (→ 544), ... , 181 (→ 582)
A 352 053 40 31	MERCEDES-BENZ	92-16114	MERCEDES-BENZ	126 (→ 544), ... , 181 (→ 582)
A 352 054 05 01	MERCEDES-BENZ	20100335260	MERCEDES-BENZ	126 (→ 544), ... , 236 (→ 615)
A 355 050 01 27	MERCEDES-BENZ	1658	MERCEDES-BENZ	359 (→ 704), ... , 474 (→ 824)
A 355 051 04 01	MERCEDES-BENZ	20100335500	MERCEDES-BENZ	359 (→ 704), ... , 474 (→ 824)
A 355 051 10 01	MERCEDES-BENZ	20100335501	MERCEDES-BENZ	360 (→ 705), ... , 377 (→ 720)
A 355 053 00 32	MERCEDES-BENZ	92-16118	MERCEDES-BENZ	366 (→ 708), 377 (→ 720)
A 355 053 03 30	MERCEDES-BENZ	81-1641	MERCEDES-BENZ	359 (→ 704), ... , 474 (→ 824)
A 355 053 04 32	MERCEDES-BENZ	92-16146	MERCEDES-BENZ	366 (→ 708), ... , 377 (→ 720)
A 355 053 05 31	MERCEDES-BENZ	92-16145	MERCEDES-BENZ	366 (→ 708), 377 (→ 720)
A 355 053 06 32	MERCEDES-BENZ	92-16110	MERCEDES-BENZ	359 (→ 704), ... , 474 (→ 824)
A 355 053 09 31	MERCEDES-BENZ	92-16142	MERCEDES-BENZ	359 (→ 704), ... , 474 (→ 824)
A 355 053 10 32	MERCEDES-BENZ	92-16110	MERCEDES-BENZ	359 (→ 704), ... , 474 (→ 824)
A 355 053 11 31	MERCEDES-BENZ	92-16106	MERCEDES-BENZ	359 (→ 704), ... , 474 (→ 824)
A 355 053 12 32	MERCEDES-BENZ	92-16143	MERCEDES-BENZ	359 (→ 704), ... , 474 (→ 824)
A 355 053 13 31	MERCEDES-BENZ	92-16142	MERCEDES-BENZ	359 (→ 704), ... , 474 (→ 824)
A 355 053 18 32	MERCEDES-BENZ	92-16110	MERCEDES-BENZ	359 (→ 704), ... , 474 (→ 824)
A 355 053 20 32	MERCEDES-BENZ	92-16143	MERCEDES-BENZ	359 (→ 704), ... , 474 (→ 824)
A 355 054 01 01	MERCEDES-BENZ	20100335560	MERCEDES-BENZ	359 (→ 704), ... , 474 (→ 824)
A 360 050 01 27	MERCEDES-BENZ	1610	MERCEDES-BENZ	321 (→ 665)
A 360 050 02 27	MERCEDES-BENZ	1610	MERCEDES-BENZ	321 (→ 665)
A 360 050 03 26	MERCEDES-BENZ	1659	MERCEDES-BENZ	321 (→ 665)
A 360 053 00 29	MERCEDES-BENZ	81-1650	MERCEDES-BENZ	321 (→ 665)

Reference	Item No.	Pos (→  )		
A 360 053 00 30	MERCEDES-BENZ	81-1654	MERCEDES-BENZ	321 (→ 665)
A 360 053 01 32	MERCEDES-BENZ	92-16133	MERCEDES-BENZ	321 (→ 666)
A 360 053 02 32	MERCEDES-BENZ	92-16135	MERCEDES-BENZ	321 (→ 666)
A 360 053 03 32	MERCEDES-BENZ	92-16137	MERCEDES-BENZ	321 (→ 666)
A 360 053 06 31	MERCEDES-BENZ	92-16132	MERCEDES-BENZ	321 (→ 666)
A 360 053 07 31	MERCEDES-BENZ	92-16134	MERCEDES-BENZ	321 (→ 666)
A 360 053 08 31	MERCEDES-BENZ	92-16136	MERCEDES-BENZ	321 (→ 666)
A 364 050 03 01	MERCEDES-BENZ	20100336400	MERCEDES-BENZ	188 (→ 585), ... , 223 (→ 608)
A 364 050 04 01	MERCEDES-BENZ	20100336401	MERCEDES-BENZ	167 (→ 573), ... , 217 (→ 604)
A 364 050 06 01	MERCEDES-BENZ	20100336401	MERCEDES-BENZ	167 (→ 573), ... , 217 (→ 604)
A 366 050 00 27	MERCEDES-BENZ	16106	MERCEDES-BENZ	128 (→ 545), ... , 236 (→ 615)
A 366 050 01 27	MERCEDES-BENZ	16106	MERCEDES-BENZ	128 (→ 545), ... , 236 (→ 615)
A 366 050 02 26	MERCEDES-BENZ	16109	MERCEDES-BENZ	128 (→ 545), ... , 236 (→ 615)
A 366 050 02 27	MERCEDES-BENZ	16122	MERCEDES-BENZ	128 (→ 545), ... , 236 (→ 615)
A 366 050 03 01	MERCEDES-BENZ	20100336600	MERCEDES-BENZ	184 (→ 582), ... , 208 (→ 598)
A 366 050 03 26	MERCEDES-BENZ	16130	MERCEDES-BENZ	140 (→ 554), ... , 236 (→ 615)
A 366 050 04 01	MERCEDES-BENZ	20100336601	MERCEDES-BENZ	144 (→ 557), ... , 235 (→ 614)
A 366 050 04 33	MERCEDES-BENZ	20100336602	MERCEDES-BENZ	129 (→ 546), ... , 236 (→ 615)
A 366 050 05 27	MERCEDES-BENZ	16106	MERCEDES-BENZ	128 (→ 545), ... , 236 (→ 615)
A 366 050 06 01	MERCEDES-BENZ	20100336601	MERCEDES-BENZ	144 (→ 557), ... , 235 (→ 614)
A 366 050 06 27	MERCEDES-BENZ	16106	MERCEDES-BENZ	128 (→ 545), ... , 236 (→ 615)
A 366 050 12 26	MERCEDES-BENZ	261100	MERCEDES-BENZ	170 (→ 575), ... , 236 (→ 615)
A 366 051 11 01	MERCEDES-BENZ	20100336601	MERCEDES-BENZ	144 (→ 557), ... , 235 (→ 614)
A 366 053 02 30	MERCEDES-BENZ	81-1676	MERCEDES-BENZ	126 (→ 544), ... , 236 (→ 615)
A 366 053 07 29	MERCEDES-BENZ	81-1674	MERCEDES-BENZ	126 (→ 544), ... , 236 (→ 615)
A 366 053 09 31	MERCEDES-BENZ	92-16153	MERCEDES-BENZ	143 (→ 556), ... , 236 (→ 615)
A 366 053 10 31	MERCEDES-BENZ	92-16116	MERCEDES-BENZ	143 (→ 556), ... , 236 (→ 615)
A 366 053 12 31	MERCEDES-BENZ	92-16153	MERCEDES-BENZ	143 (→ 556), ... , 236 (→ 615)
A 366 053 14 31	MERCEDES-BENZ	92-16153	MERCEDES-BENZ	143 (→ 556), ... , 236 (→ 615)
A 366 053 16 32	MERCEDES-BENZ	92-16109	MERCEDES-BENZ	126 (→ 544), ... , 235 (→ 614)
A 366 053 20 32	MERCEDES-BENZ	92-16154	MERCEDES-BENZ	185 (→ 583), ... , 236 (→ 615)
A 366 053 35 31	MERCEDES-BENZ	92-16155	MERCEDES-BENZ	165 (→ 572), ... , 236 (→ 615)
A 376 050 00 27	MERCEDES-BENZ	16106	MERCEDES-BENZ	128 (→ 545), ... , 236 (→ 615)
A 376 050 01 27	MERCEDES-BENZ	16106	MERCEDES-BENZ	128 (→ 545), ... , 236 (→ 615)
A 401 050 19 01	MERCEDES-BENZ	20100340101	MERCEDES-BENZ	336 (→ 686), ... , 479 (→ 831)
A 401 050 22 01	MERCEDES-BENZ	20100340101	MERCEDES-BENZ	336 (→ 686), ... , 479 (→ 831)
A 402 010 03 20	MERCEDES-BENZ	20080340300	MERCEDES-BENZ	315 (→ 664), ... , 541 (→ 903)
A 402 050 11 01	MERCEDES-BENZ	20100340200	MERCEDES-BENZ	315 (→ 663), ... , 345 (→ 694)
A 402 050 13 01	MERCEDES-BENZ	20100340200	MERCEDES-BENZ	315 (→ 663), ... , 345 (→ 694)
A 402 050 16 01	MERCEDES-BENZ	20100340200	MERCEDES-BENZ	315 (→ 663), ... , 345 (→ 694)
A 402 050 18 01	MERCEDES-BENZ	20100340200	MERCEDES-BENZ	315 (→ 663), ... , 345 (→ 694)
A 402 050 21 01	MERCEDES-BENZ	20100340201	MERCEDES-BENZ	337 (→ 688), ... , 432 (→ 782)
A 402 050 25 01	MERCEDES-BENZ	20100340201	MERCEDES-BENZ	337 (→ 688), ... , 432 (→ 782)
A 403 010 40 20	MERCEDES-BENZ	20080340300	MERCEDES-BENZ	315 (→ 664), ... , 541 (→ 903)
A 403 010 89 20	MERCEDES-BENZ	20080340300	MERCEDES-BENZ	315 (→ 664), ... , 541 (→ 903)
A 403 050 03 33	MERCEDES-BENZ	20100340010	MERCEDES-BENZ	315 (→ 664), ... , 541 (→ 903)
A 403 050 03 33	MERCEDES-BENZ	20100340012	MERCEDES-BENZ	315 (→ 664), ... , 541 (→ 903)
A 403 050 07 33	MERCEDES-BENZ	20100225010	MERCEDES-BENZ	315 (→ 664), ... , 541 (→ 903)
A 403 050 07 33	MERCEDES-BENZ	20100340010	MERCEDES-BENZ	315 (→ 664), ... , 541 (→ 903)
A 403 050 07 33	MERCEDES-BENZ	20100340012	MERCEDES-BENZ	315 (→ 664), ... , 541 (→ 903)
A 403 053 00 30	MERCEDES-BENZ	81-1647	MERCEDES-BENZ	315 (→ 663), ... , 484 (→ 835)
A 403 053 00 32	MERCEDES-BENZ	92-16104	MERCEDES-BENZ	315 (→ 663), ... , 541 (→ 902)
A 403 053 01 30	MERCEDES-BENZ	81-1648	MERCEDES-BENZ	315 (→ 663), ... , 484 (→ 835)
A 403 053 01 32	MERCEDES-BENZ	92-16148	MERCEDES-BENZ	315 (→ 663), ... , 541 (→ 902)
A 403 053 02 32	MERCEDES-BENZ	92-16105	MERCEDES-BENZ	315 (→ 663), ... , 541 (→ 902)
A 403 053 03 31	MERCEDES-BENZ	92-16163	MERCEDES-BENZ	315 (→ 663), ... , 348 (→ 698)
A 403 053 03 32	MERCEDES-BENZ	92-16104	MERCEDES-BENZ	315 (→ 663), ... , 541 (→ 902)
A 403 053 09 01	MERCEDES-BENZ	16117	MERCEDES-BENZ	315 (→ 663), ... , 541 (→ 902)
A 403 053 09 31	MERCEDES-BENZ	92-16100	MERCEDES-BENZ	315 (→ 663), ... , 541 (→ 902)
A 403 053 10 31	MERCEDES-BENZ	92-16147	MERCEDES-BENZ	315 (→ 663), ... , 541 (→ 902)
A 403 053 11 31	MERCEDES-BENZ	92-16101	MERCEDES-BENZ	315 (→ 663), ... , 541 (→ 902)
A 403 053 13 32	MERCEDES-BENZ	92-16148	MERCEDES-BENZ	315 (→ 663), ... , 541 (→ 902)
A 403 053 15 31	MERCEDES-BENZ	92-16100	MERCEDES-BENZ	315 (→ 663), ... , 541 (→ 902)
A 403 053 21 32	MERCEDES-BENZ	92-16104	MERCEDES-BENZ	315 (→ 663), ... , 541 (→ 902)
A 403 053 22 32	MERCEDES-BENZ	92-16148	MERCEDES-BENZ	315 (→ 663), ... , 541 (→ 902)

# ALPHANUMERICAL LIST

Reference	Item No.	Pos (→  )		
A 403 053 23 32	MERCEDES-BENZ	92-16105	MERCEDES-BENZ	315 (→ 663), ... , 541 (→ 902)
A 403 053 25 32	MERCEDES-BENZ	92-16104	MERCEDES-BENZ	315 (→ 663), ... , 541 (→ 902)
A 403 053 26 32	MERCEDES-BENZ	92-16148	MERCEDES-BENZ	315 (→ 663), ... , 541 (→ 902)
A 403 053 27 32	MERCEDES-BENZ	92-16105	MERCEDES-BENZ	315 (→ 663), ... , 541 (→ 902)
A 403 053 28 32	MERCEDES-BENZ	92-16104	MERCEDES-BENZ	315 (→ 663), ... , 541 (→ 902)
A 403 053 29 32	MERCEDES-BENZ	92-16148	MERCEDES-BENZ	315 (→ 663), ... , 541 (→ 902)
A 403 053 30 32	MERCEDES-BENZ	92-16105	MERCEDES-BENZ	315 (→ 663), ... , 541 (→ 902)
A 403 054 09 01	MERCEDES-BENZ	20100340060	MERCEDES-BENZ	315 (→ 664), ... , 509 (→ 860)
A 403 054 18 01	MERCEDES-BENZ	20100340060	MERCEDES-BENZ	315 (→ 664), ... , 509 (→ 860)
A 407 050 01 27	MERCEDES-BENZ	162031	MERCEDES-BENZ	354 (→ 702), ... , 356 (→ 703)
A 407 053 04 31	MERCEDES-BENZ	92-16161	MERCEDES-BENZ	354 (→ 702), ... , 358 (→ 704)
A 422 050 00 01	MERCEDES-BENZ	20100342201	MERCEDES-BENZ	378 (→ 721), ... , 476 (→ 827)
A 422 050 00 26	MERCEDES-BENZ	16117	MERCEDES-BENZ	315 (→ 663), ... , 541 (→ 902)
A 422 050 00 27	MERCEDES-BENZ	16116	MERCEDES-BENZ	315 (→ 663), ... , 541 (→ 902)
A 422 050 01 01	MERCEDES-BENZ	20100342200	MERCEDES-BENZ	370 (→ 712), ... , 541 (→ 902)
A 422 050 01 27	MERCEDES-BENZ	16150	MERCEDES-BENZ	315 (→ 663), ... , 541 (→ 902)
A 422 050 02 26	MERCEDES-BENZ	16117	MERCEDES-BENZ	315 (→ 663), ... , 541 (→ 902)
A 422 050 02 27	MERCEDES-BENZ	16150	MERCEDES-BENZ	315 (→ 663), ... , 541 (→ 902)
A 422 050 03 01	MERCEDES-BENZ	20100342200	MERCEDES-BENZ	370 (→ 712), ... , 541 (→ 902)
A 422 050 03 25	MERCEDES-BENZ	20100344000	MERCEDES-BENZ	315 (→ 664), ... , 509 (→ 860)
A 422 050 03 25	MERCEDES-BENZ	20100344001	MERCEDES-BENZ	315 (→ 664), ... , 509 (→ 860)
A 422 050 04 01	MERCEDES-BENZ	20100342201	MERCEDES-BENZ	378 (→ 721), ... , 476 (→ 827)
A 422 050 05 01	MERCEDES-BENZ	20100342200	MERCEDES-BENZ	370 (→ 712), ... , 541 (→ 902)
A 422 050 05 26	MERCEDES-BENZ	16117	MERCEDES-BENZ	315 (→ 663), ... , 541 (→ 902)
A 422 050 10 01	MERCEDES-BENZ	20100342201	MERCEDES-BENZ	378 (→ 721), ... , 476 (→ 827)
A 422 050 21 01	MERCEDES-BENZ	20100342200	MERCEDES-BENZ	370 (→ 712), ... , 541 (→ 902)
A 422 050 22 01	MERCEDES-BENZ	20100342201	MERCEDES-BENZ	378 (→ 721), ... , 476 (→ 827)
A 422 053 00 26	MERCEDES-BENZ	LK-1610	MERCEDES-BENZ	315 (→ 663), ... , 541 (→ 902)
A 422 053 01 01	MERCEDES-BENZ	16117	MERCEDES-BENZ	315 (→ 663), ... , 541 (→ 902)
A 422 053 01 31	MERCEDES-BENZ	92-16150	MERCEDES-BENZ	362 (→ 706), ... , 484 (→ 835)
A 422 053 01 32	MERCEDES-BENZ	92-16126	MERCEDES-BENZ	332 (→ 682), ... , 505 (→ 854)
A 422 053 04 30	MERCEDES-BENZ	81-16100	MERCEDES-BENZ	315 (→ 663), ... , 541 (→ 902)
A 422 053 05 31	MERCEDES-BENZ	92-16151	MERCEDES-BENZ	332 (→ 682), ... , 508 (→ 859)
A 422 053 06 31	MERCEDES-BENZ	92-16152	MERCEDES-BENZ	332 (→ 682), ... , 508 (→ 859)
A 423 050 00 26	MERCEDES-BENZ	1606	MERCEDES-BENZ	315 (→ 663), ... , 476 (→ 826)
A 423 050 00 26	MERCEDES-BENZ	16117	MERCEDES-BENZ	315 (→ 663), ... , 541 (→ 902)
A 423 050 04 27	MERCEDES-BENZ	1608	MERCEDES-BENZ	315 (→ 663), ... , 476 (→ 826)
A 427 010 00 20	MERCEDES-BENZ	20080340300	MERCEDES-BENZ	315 (→ 664), ... , 541 (→ 903)
A 427 010 10 20	MERCEDES-BENZ	20080340300	MERCEDES-BENZ	315 (→ 664), ... , 541 (→ 903)
A 427 010 10 20	MERCEDES-BENZ	20080340301	MERCEDES-BENZ	315 (→ 664), ... , 541 (→ 903)
A 429 010 02 20	MERCEDES-BENZ	20080340300	MERCEDES-BENZ	315 (→ 664), ... , 541 (→ 903)
A 441 050 17 01	MERCEDES-BENZ	20100340101	MERCEDES-BENZ	336 (→ 686), ... , 479 (→ 831)
A 442 010 06 20	MERCEDES-BENZ	20080344000	MERCEDES-BENZ	372 (→ 716), ... , 480 (→ 832)
A 442 010 06 20	MERCEDES-BENZ	20080344010	MERCEDES-BENZ	372 (→ 716), ... , 480 (→ 832)
A 442 010 07 20	MERCEDES-BENZ	20080340300	MERCEDES-BENZ	315 (→ 664), ... , 541 (→ 903)
A 442 016 01 91	MERCEDES-BENZ	50 004 664	MERCEDES-BENZ	413 (→ 760), 414 (→ 761)
A 442 016 02 91	MERCEDES-BENZ	50 004 665	MERCEDES-BENZ	372 (→ 715), ... , 506 (→ 855)
A 442 016 03 91	MERCEDES-BENZ	50 004 665	MERCEDES-BENZ	372 (→ 715), ... , 506 (→ 855)
A 442 050 01 26	MERCEDES-BENZ	16202	MERCEDES-BENZ	354 (→ 702), ... , 356 (→ 703)
A 442 050 01 27	MERCEDES-BENZ	16150	MERCEDES-BENZ	315 (→ 663), ... , 541 (→ 902)
A 442 050 02 26	MERCEDES-BENZ	16117	MERCEDES-BENZ	315 (→ 663), ... , 541 (→ 902)
A 442 050 02 27	MERCEDES-BENZ	16150	MERCEDES-BENZ	315 (→ 663), ... , 541 (→ 902)
A 442 050 03 26	MERCEDES-BENZ	16117	MERCEDES-BENZ	315 (→ 663), ... , 541 (→ 902)
A 442 050 03 27	MERCEDES-BENZ	16150	MERCEDES-BENZ	315 (→ 663), ... , 541 (→ 902)
A 442 050 03 33	MERCEDES-BENZ	20100225010	MERCEDES-BENZ	315 (→ 664), ... , 541 (→ 903)
A 442 050 03 33	MERCEDES-BENZ	20100340010	MERCEDES-BENZ	315 (→ 664), ... , 541 (→ 903)
A 442 050 03 33	MERCEDES-BENZ	20100340012	MERCEDES-BENZ	315 (→ 664), ... , 541 (→ 903)
A 442 050 04 27	MERCEDES-BENZ	16150	MERCEDES-BENZ	315 (→ 663), ... , 541 (→ 902)
A 442 050 05 26	MERCEDES-BENZ	16146	MERCEDES-BENZ	315 (→ 663), ... , 541 (→ 902)
A 442 050 06 26	MERCEDES-BENZ	16202	MERCEDES-BENZ	354 (→ 702), ... , 356 (→ 703)
A 442 050 07 26	MERCEDES-BENZ	16202	MERCEDES-BENZ	354 (→ 702), ... , 356 (→ 703)
A 442 050 08 01	MERCEDES-BENZ	20100344201	MERCEDES-BENZ	436 (→ 787), ... , 480 (→ 832)
A 442 050 11 01	MERCEDES-BENZ	20100344201	MERCEDES-BENZ	436 (→ 787), ... , 480 (→ 832)
A 442 050 17 01	MERCEDES-BENZ	20100340201	MERCEDES-BENZ	337 (→ 688), ... , 432 (→ 782)
A 442 053 00 32	MERCEDES-BENZ	92-16127	MERCEDES-BENZ	332 (→ 682), ... , 505 (→ 854)



# ALPHANUMERICAL LIST

Reference	Item No.	Pos (→  )		
A 442 053 01 32	MERCEDES-BENZ	92-16149	MERCEDES-BENZ	332 (→ 682), ... , 505 (→ 854)
A 442 053 02 32	MERCEDES-BENZ	92-16128	MERCEDES-BENZ	332 (→ 682), ... , 505 (→ 854)
A 442 053 05 31	MERCEDES-BENZ	92-16122	MERCEDES-BENZ	372 (→ 715), ... , 479 (→ 830)
A 442 053 07 31	MERCEDES-BENZ	92-16123	MERCEDES-BENZ	372 (→ 715), ... , 479 (→ 830)
A 442 055 00 20	MERCEDES-BENZ	20100340012	MERCEDES-BENZ	315 (→ 664), ... , 541 (→ 903)
A 447 050 00 27	MERCEDES-BENZ	162031	MERCEDES-BENZ	354 (→ 702), ... , 356 (→ 703)
A 447 050 03 27	MERCEDES-BENZ	162031	MERCEDES-BENZ	354 (→ 702), ... , 356 (→ 703)
A 447 050 19 01	MERCEDES-BENZ	20100344701	MERCEDES-BENZ	400 (→ 749), ... , 464 (→ 816)
A 447 053 00 31	MERCEDES-BENZ	92-16150	MERCEDES-BENZ	362 (→ 706), ... , 484 (→ 835)
A 447 053 08 32	MERCEDES-BENZ	92-16162	MERCEDES-BENZ	354 (→ 702), ... , 358 (→ 704)
A 457 050 03 27	MERCEDES-BENZ	16205	MERCEDES-BENZ	437 (→ 788), ... , 555 (→ 914)
A 457 050 05 27	MERCEDES-BENZ	16205	MERCEDES-BENZ	437 (→ 788), ... , 555 (→ 914)
A 457 050 13 01	MERCEDES-BENZ	20100345700	MERCEDES-BENZ	437 (→ 788), ... , 492 (→ 841)
A 457 050 23 01	MERCEDES-BENZ	20100346000	MERCEDES-BENZ	446 (→ 798), ... , 496 (→ 844)
A 457 050 25 01	MERCEDES-BENZ	20100345701	MERCEDES-BENZ	440 (→ 792), ... , 460 (→ 813)
A 457 050 30 01	MERCEDES-BENZ	20100346000	MERCEDES-BENZ	446 (→ 798), ... , 496 (→ 844)
A 457 050 31 01	MERCEDES-BENZ	20100345704	MERCEDES-BENZ	441 (→ 793), ... , 489 (→ 839)
A 457 053 00 01	MERCEDES-BENZ	160054	MERCEDES-BENZ	437 (→ 788), ... , 553 (→ 912)
A 457 053 12 30	MERCEDES-BENZ	81-16103	MERCEDES-BENZ	437 (→ 788), ... , 555 (→ 914)
A 457 053 13 30	MERCEDES-BENZ	81-16104	MERCEDES-BENZ	437 (→ 788), ... , 555 (→ 914)
A 457 053 13 32	MERCEDES-BENZ	92-16170	MERCEDES-BENZ	441 (→ 793), ... , 555 (→ 914)
A 457 053 16 31	MERCEDES-BENZ	92-16156	MERCEDES-BENZ	437 (→ 788), ... , 549 (→ 910)
A 460 050 01 01	MERCEDES-BENZ	20100346000	MERCEDES-BENZ	446 (→ 798), ... , 496 (→ 844)
A 460 050 04 01	MERCEDES-BENZ	20100346000	MERCEDES-BENZ	446 (→ 798), ... , 496 (→ 844)
A 460 050 06 01	MERCEDES-BENZ	20100346005	MERCEDES-BENZ	448 (→ 800), ... , 497 (→ 845)
A 460 053 00 01	MERCEDES-BENZ	16204	MERCEDES-BENZ	437 (→ 788), ... , 555 (→ 914)
A 470 050 04 01	MERCEDES-BENZ	20100347000	MERCEDES-BENZ	341 (→ 691), ... , 352 (→ 701)
A 470 050 04 27	MERCEDES-BENZ	162170	MERCEDES-BENZ	341 (→ 691), ... , 352 (→ 701)
A 470 050 05 01	MERCEDES-BENZ	20100347001	MERCEDES-BENZ	341 (→ 691), ... , 352 (→ 701)
A 470 050 06 26	MERCEDES-BENZ	162160	MERCEDES-BENZ	341 (→ 691), ... , 352 (→ 701)
A 470 050 06 27	MERCEDES-BENZ	162170	MERCEDES-BENZ	341 (→ 691), ... , 352 (→ 701)
A 470 050 08 01	MERCEDES-BENZ	20100347000	MERCEDES-BENZ	341 (→ 691), ... , 352 (→ 701)
A 470 050 08 26	MERCEDES-BENZ	162160	MERCEDES-BENZ	341 (→ 691), ... , 352 (→ 701)
A 470 050 10 01	MERCEDES-BENZ	20100347001	MERCEDES-BENZ	341 (→ 691), ... , 352 (→ 701)
A 471 050 00 33	MERCEDES-BENZ	20100347110	MERCEDES-BENZ	556 (→ 915), ... , 566 (→ 918)
A 471 050 00 34	MERCEDES-BENZ	20100347111	MERCEDES-BENZ	341 (→ 691), ... , 569 (→ 918)
A 471 050 03 33	MERCEDES-BENZ	20100347110	MERCEDES-BENZ	556 (→ 915), ... , 566 (→ 918)
A 471 050 04 26	MERCEDES-BENZ	16211	MERCEDES-BENZ	556 (→ 915), ... , 561 (→ 917)
A 471 050 05 27	MERCEDES-BENZ	16212	MERCEDES-BENZ	556 (→ 915), ... , 561 (→ 917)
A 471 050 09 26	MERCEDES-BENZ	16211	MERCEDES-BENZ	556 (→ 915), ... , 561 (→ 917)
A 471 050 09 27	MERCEDES-BENZ	16212	MERCEDES-BENZ	556 (→ 915), ... , 561 (→ 917)
A 471 050 13 01	MERCEDES-BENZ	20100347100	MERCEDES-BENZ	556 (→ 915), ... , 565 (→ 917)
A 471 050 13 26	MERCEDES-BENZ	16211	MERCEDES-BENZ	556 (→ 915), ... , 561 (→ 917)
A 471 050 14 01	MERCEDES-BENZ	20100347102	MERCEDES-BENZ	556 (→ 915), ... , 565 (→ 917)
A 471 050 17 01	MERCEDES-BENZ	20100347100	MERCEDES-BENZ	556 (→ 915), ... , 565 (→ 917)
A 471 050 18 01	MERCEDES-BENZ	20100347101	MERCEDES-BENZ	556 (→ 915), ... , 565 (→ 917)
A 471 050 19 01	MERCEDES-BENZ	20100347104	MERCEDES-BENZ	556 (→ 915), 558 (→ 916)
A 471 050 20 01	MERCEDES-BENZ	20100347103	MERCEDES-BENZ	556 (→ 915), ... , 565 (→ 917)
A 472 050 02 26	MERCEDES-BENZ	162180	MERCEDES-BENZ	567 (→ 918), 570 (→ 919)
A 472 050 03 26	MERCEDES-BENZ	162180	MERCEDES-BENZ	567 (→ 918), 570 (→ 919)
A 472 050 38 34	MERCEDES-BENZ	20100347112	MERCEDES-BENZ	341 (→ 691), ... , 566 (→ 918)
A 472 050 42 34	MERCEDES-BENZ	20100347112	MERCEDES-BENZ	341 (→ 691), ... , 566 (→ 918)
A 472 053 00 26	MERCEDES-BENZ	RK-9.5H	MERCEDES-BENZ	341 (→ 691), ... , 570 (→ 919)
A 473 050 01 26	MERCEDES-BENZ	162180	MERCEDES-BENZ	567 (→ 918), 570 (→ 919)
A 473 050 01 27	MERCEDES-BENZ	162190	MERCEDES-BENZ	567 (→ 918), 570 (→ 919)
A 473 050 02 27	MERCEDES-BENZ	162190	MERCEDES-BENZ	567 (→ 918), 570 (→ 919)
A 473 050 05 27	MERCEDES-BENZ	162190	MERCEDES-BENZ	567 (→ 918), 570 (→ 919)
A 473 050 06 26	MERCEDES-BENZ	162180	MERCEDES-BENZ	567 (→ 918), 570 (→ 919)
A 476 050 00 25	MERCEDES-BENZ	20100344000	MERCEDES-BENZ	315 (→ 664), ... , 509 (→ 860)
A 476 050 00 25	MERCEDES-BENZ	20100344001	MERCEDES-BENZ	315 (→ 664), ... , 509 (→ 860)
A 541 010 19 20	MERCEDES-BENZ	20080350110	MERCEDES-BENZ	514 (→ 868), ... , 534 (→ 897)
A 541 010 27 20	MERCEDES-BENZ	20080350110	MERCEDES-BENZ	514 (→ 868), ... , 534 (→ 897)
A 541 010 34 21	MERCEDES-BENZ	20080350110	MERCEDES-BENZ	514 (→ 868), ... , 534 (→ 897)
A 541 010 34 21	MERCEDES-BENZ	20080350111	MERCEDES-BENZ	514 (→ 868), ... , 534 (→ 897)
A 541 010 37 21	MERCEDES-BENZ	20080350100	MERCEDES-BENZ	510 (→ 862), ... , 543 (→ 905)

# ALPHANUMERICAL LIST

Reference	Item No.	Pos (→  )		
A 541 010 37 21	MERCEDES-BENZ	20080350101	MERCEDES-BENZ	510 (→ 862), ... , 543 (→ 905)
A 541 010 45 20	MERCEDES-BENZ	20080350110	MERCEDES-BENZ	514 (→ 868), ... , 534 (→ 897)
A 541 010 50 20	MERCEDES-BENZ	20080350100	MERCEDES-BENZ	510 (→ 862), ... , 543 (→ 905)
A 541 010 50 20	MERCEDES-BENZ	20080350101	MERCEDES-BENZ	510 (→ 862), ... , 543 (→ 905)
A 541 010 53 20	MERCEDES-BENZ	20080350110	MERCEDES-BENZ	514 (→ 868), ... , 534 (→ 897)
A 541 010 53 20	MERCEDES-BENZ	20080350111	MERCEDES-BENZ	514 (→ 868), ... , 534 (→ 897)
A 541 010 64 20	MERCEDES-BENZ	20080350100	MERCEDES-BENZ	510 (→ 862), ... , 543 (→ 905)
A 541 010 64 20	MERCEDES-BENZ	20080350101	MERCEDES-BENZ	510 (→ 862), ... , 543 (→ 905)
A 541 016 05 91	MERCEDES-BENZ	261101	MERCEDES-BENZ	437 (→ 788), ... , 553 (→ 912)
A 541 016 06 91	MERCEDES-BENZ	261101	MERCEDES-BENZ	437 (→ 788), ... , 553 (→ 912)
A 541 016 07 91	MERCEDES-BENZ	261101	MERCEDES-BENZ	437 (→ 788), ... , 553 (→ 912)
A 541 050 01 27	MERCEDES-BENZ	160055	MERCEDES-BENZ	437 (→ 788), ... , 553 (→ 912)
A 541 050 02 26	MERCEDES-BENZ	160054	MERCEDES-BENZ	437 (→ 788), ... , 553 (→ 912)
A 541 050 02 27	MERCEDES-BENZ	160055	MERCEDES-BENZ	437 (→ 788), ... , 553 (→ 912)
A 541 050 03 22	MERCEDES-BENZ	20100350060	MERCEDES-BENZ	437 (→ 788), ... , 554 (→ 914)
A 541 050 04 33	MERCEDES-BENZ	20100350010	MERCEDES-BENZ	437 (→ 788), ... , 555 (→ 915)
A 541 050 05 22	MERCEDES-BENZ	20100350060	MERCEDES-BENZ	437 (→ 788), ... , 554 (→ 914)
A 541 050 05 34	MERCEDES-BENZ	20100350011	MERCEDES-BENZ	437 (→ 788), ... , 555 (→ 915)
A 541 050 06 33	MERCEDES-BENZ	20100350010	MERCEDES-BENZ	437 (→ 788), ... , 555 (→ 915)
A 541 050 06 34	MERCEDES-BENZ	20100350011	MERCEDES-BENZ	437 (→ 788), ... , 555 (→ 915)
A 541 050 07 22	MERCEDES-BENZ	20100350060	MERCEDES-BENZ	437 (→ 788), ... , 554 (→ 914)
A 541 050 07 33	MERCEDES-BENZ	20100350010	MERCEDES-BENZ	437 (→ 788), ... , 555 (→ 915)
A 541 050 07 34	MERCEDES-BENZ	20100350011	MERCEDES-BENZ	437 (→ 788), ... , 555 (→ 915)
A 541 050 08 33	MERCEDES-BENZ	20100350010	MERCEDES-BENZ	437 (→ 788), ... , 555 (→ 915)
A 541 050 08 34	MERCEDES-BENZ	20100350011	MERCEDES-BENZ	437 (→ 788), ... , 555 (→ 915)
A 541 050 09 33	MERCEDES-BENZ	20100350010	MERCEDES-BENZ	437 (→ 788), ... , 555 (→ 915)
A 541 050 10 01	MERCEDES-BENZ	20100350100	MERCEDES-BENZ	523 (→ 881)
A 541 050 13 22	MERCEDES-BENZ	20100350060	MERCEDES-BENZ	437 (→ 788), ... , 554 (→ 914)
A 541 050 16 01	MERCEDES-BENZ	20100350101	MERCEDES-BENZ	512 (→ 864), ... , 548 (→ 909)
A 541 050 17 22	MERCEDES-BENZ	20100350062	MERCEDES-BENZ	437 (→ 788), ... , 555 (→ 914)
A 541 050 18 01	MERCEDES-BENZ	20100350101	MERCEDES-BENZ	512 (→ 864), ... , 548 (→ 909)
A 541 050 20 22	MERCEDES-BENZ	20100350062	MERCEDES-BENZ	437 (→ 788), ... , 555 (→ 914)
A 541 050 21 01	MERCEDES-BENZ	20100354100	MERCEDES-BENZ	516 (→ 870), ... , 547 (→ 908)
A 541 053 00 26	MERCEDES-BENZ	LK-2615	MERCEDES-BENZ	437 (→ 788), ... , 555 (→ 914)
A 541 053 01 01	MERCEDES-BENZ	16204	MERCEDES-BENZ	437 (→ 788), ... , 555 (→ 914)
A 541 053 01 26	MERCEDES-BENZ	LK-2615	MERCEDES-BENZ	437 (→ 788), ... , 555 (→ 914)
A 541 053 02 26	MERCEDES-BENZ	LK-2615	MERCEDES-BENZ	437 (→ 788), ... , 555 (→ 914)
A 541 053 05 32	MERCEDES-BENZ	92-16158	MERCEDES-BENZ	437 (→ 788), ... , 555 (→ 914)
A 541 053 12 30	MERCEDES-BENZ	81-16103	MERCEDES-BENZ	437 (→ 788), ... , 555 (→ 914)
A 541 053 13 30	MERCEDES-BENZ	81-16104	MERCEDES-BENZ	437 (→ 788), ... , 555 (→ 914)
A 541 053 17 31	MERCEDES-BENZ	92-16157	MERCEDES-BENZ	437 (→ 788), ... , 555 (→ 914)
A 541 053 21 31	MERCEDES-BENZ	92-16157	MERCEDES-BENZ	437 (→ 788), ... , 555 (→ 914)
A 541 053 26 31	MERCEDES-BENZ	92-16157	MERCEDES-BENZ	437 (→ 788), ... , 555 (→ 914)
A 541 053 27 30	MERCEDES-BENZ	81-16103	MERCEDES-BENZ	437 (→ 788), ... , 555 (→ 914)
A 541 053 28 30	MERCEDES-BENZ	81-16104	MERCEDES-BENZ	437 (→ 788), ... , 555 (→ 914)
A 541 055 07 50	MERCEDES-BENZ	20100350010	MERCEDES-BENZ	437 (→ 788), ... , 555 (→ 915)
A 542 050 06 01	MERCEDES-BENZ	20100350200	MERCEDES-BENZ	520 (→ 877), ... , 527 (→ 889)
A 542 050 14 01	MERCEDES-BENZ	20100350201	MERCEDES-BENZ	510 (→ 861), ... , 553 (→ 913)
A 542 050 17 01	MERCEDES-BENZ	20100354200	MERCEDES-BENZ	528 (→ 890), ... , 555 (→ 914)
A 601 050 00 80	MERCEDES-BENZ	50 006 456	MERCEDES-BENZ	60 (→ 517), ... , 88 (→ 532)
A 601 050 02 27	MERCEDES-BENZ	26032	MERCEDES-BENZ	60 (→ 516), ... , 88 (→ 531)
A 601 050 03 25	MERCEDES-BENZ	50 006 456	MERCEDES-BENZ	60 (→ 517), ... , 88 (→ 532)
A 601 050 03 80	MERCEDES-BENZ	50 006 456	MERCEDES-BENZ	60 (→ 517), ... , 88 (→ 532)
A 601 050 04 25	MERCEDES-BENZ	50 006 456	MERCEDES-BENZ	60 (→ 517), ... , 88 (→ 532)
A 601 050 05 25	MERCEDES-BENZ	50 006 456	MERCEDES-BENZ	60 (→ 517), ... , 88 (→ 532)
A 601 050 05 27	MERCEDES-BENZ	26032	MERCEDES-BENZ	60 (→ 516), ... , 88 (→ 531)
A 601 050 06 24	MERCEDES-BENZ	81-1682	MERCEDES-BENZ	60 (→ 516), ... , 88 (→ 532)
A 601 050 06 25	MERCEDES-BENZ	50 006 456	MERCEDES-BENZ	60 (→ 517), ... , 88 (→ 532)
A 601 050 07 24	MERCEDES-BENZ	81-1683	MERCEDES-BENZ	60 (→ 516), ... , 88 (→ 532)
A 601 050 07 25	MERCEDES-BENZ	50 006 456	MERCEDES-BENZ	60 (→ 517), ... , 88 (→ 532)
A 601 050 08 01	MERCEDES-BENZ	50 006 282	MERCEDES-BENZ	60 (→ 517), ... , 87 (→ 531)
A 601 050 08 24	MERCEDES-BENZ	81-1684	MERCEDES-BENZ	60 (→ 516), ... , 88 (→ 532)
A 601 050 08 25	MERCEDES-BENZ	50 006 456	MERCEDES-BENZ	60 (→ 517), ... , 88 (→ 532)
A 601 050 09 24	MERCEDES-BENZ	81-1685	MERCEDES-BENZ	60 (→ 516), ... , 88 (→ 532)
A 601 050 10 24	MERCEDES-BENZ	81-1686	MERCEDES-BENZ	60 (→ 516), ... , 88 (→ 532)

# ALPHANUMERICAL LIST

Reference	Item No.	Pos ( →  )		
A 601 050 12 27	MERCEDES-BENZ	26032	MERCEDES-BENZ	60 (→ 516), ... , 88 (→ 531)
A 601 050 21 27	MERCEDES-BENZ	26032	MERCEDES-BENZ	60 (→ 516), ... , 88 (→ 531)
A 601 050 25 27	MERCEDES-BENZ	26032	MERCEDES-BENZ	60 (→ 516), ... , 88 (→ 531)
A 601 050 30 27	MERCEDES-BENZ	26032	MERCEDES-BENZ	60 (→ 516), ... , 88 (→ 531)
A 601 053 02 31	MERCEDES-BENZ	92-16121	MERCEDES-BENZ	60 (→ 516), ... , 84 (→ 529)
A 601 053 02 32	MERCEDES-BENZ	92-16125	MERCEDES-BENZ	60 (→ 516), ... , 84 (→ 529)
A 601 053 03 31	MERCEDES-BENZ	92-16120	MERCEDES-BENZ	60 (→ 516), ... , 84 (→ 529)
A 601 053 03 32	MERCEDES-BENZ	92-16124	MERCEDES-BENZ	60 (→ 516), ... , 84 (→ 529)
A 601 053 04 01	MERCEDES-BENZ	26024	MERCEDES-BENZ	60 (→ 516), ... , 88 (→ 531)
A 601 053 12 01	MERCEDES-BENZ	26024	MERCEDES-BENZ	60 (→ 516), ... , 88 (→ 531)
A 601 053 15 01	MERCEDES-BENZ	26024	MERCEDES-BENZ	60 (→ 516), ... , 88 (→ 531)
A 601 053 17 01	MERCEDES-BENZ	26024	MERCEDES-BENZ	60 (→ 516), ... , 88 (→ 531)
A 602 050 08 01	MERCEDES-BENZ	50 006 284	MERCEDES-BENZ	61 (→ 517), ... , 88 (→ 532)
A 602 050 13 01	MERCEDES-BENZ	50 006 337	MERCEDES-BENZ	85 (→ 530)
A 603 050 07 01	MERCEDES-BENZ	50 006 287	MERCEDES-BENZ	62 (→ 518), 84 (→ 529)
A 606 050 11 27	MERCEDES-BENZ	26047	MERCEDES-BENZ	65 (→ 520), 86 (→ 530)
A 606 050 14 27	MERCEDES-BENZ	26047	MERCEDES-BENZ	65 (→ 520), 86 (→ 530)
A 606 053 02 30	MERCEDES-BENZ	81-26178	MERCEDES-BENZ	65 (→ 520), 86 (→ 531)
A 606 053 05 01	MERCEDES-BENZ	26264	MERCEDES-BENZ	65 (→ 520), 86 (→ 530)
A 606 053 06 01	MERCEDES-BENZ	26264	MERCEDES-BENZ	65 (→ 520), 86 (→ 530)
A 606 053 06 05	MERCEDES-BENZ	26046	MERCEDES-BENZ	65 (→ 520), 86 (→ 530)
A 606 053 07 01	MERCEDES-BENZ	26264	MERCEDES-BENZ	65 (→ 520), 86 (→ 530)
A 606 053 07 05	MERCEDES-BENZ	26046	MERCEDES-BENZ	65 (→ 520), 86 (→ 530)
A 606 053 11 01	MERCEDES-BENZ	26045	MERCEDES-BENZ	65 (→ 520), 86 (→ 530)
A 606 053 12 29	MERCEDES-BENZ	81-26175	MERCEDES-BENZ	10 (→ 499), ... , 86 (→ 531)
A 607 050 00 00	MERCEDES-BENZ	50 007 076	MERCEDES-BENZ	6 (→ 498), 7 (→ 498)
A 607 053 12 00	MERCEDES-BENZ	539018	MERCEDES-BENZ	6 (→ 498)
A 607 053 13 00	MERCEDES-BENZ	539017	MERCEDES-BENZ	6 (→ 498)
A 611 010 23 20	MERCEDES-BENZ	50 003 119	MERCEDES-BENZ	69 (→ 521)
A 611 010 23 20	MERCEDES-BENZ	50 003 419	MERCEDES-BENZ	69 (→ 521)
A 611 010 44 20	MERCEDES-BENZ	50 003 119	MERCEDES-BENZ	69 (→ 521)
A 611 010 44 20	MERCEDES-BENZ	50 003 419	MERCEDES-BENZ	69 (→ 521)
A 611 010 50 20	MERCEDES-BENZ	50 003 122	MERCEDES-BENZ	73 (→ 523), 75 (→ 524)
A 611 010 54 20	MERCEDES-BENZ	50 003 419	MERCEDES-BENZ	69 (→ 521)
A 611 010 66 20	MERCEDES-BENZ	50 003 119	MERCEDES-BENZ	69 (→ 521)
A 611 010 66 20	MERCEDES-BENZ	50 003 419	MERCEDES-BENZ	69 (→ 521)
A 611 010 67 20	MERCEDES-BENZ	50 003 119	MERCEDES-BENZ	69 (→ 521)
A 611 010 67 20	MERCEDES-BENZ	50 003 419	MERCEDES-BENZ	69 (→ 521)
A 611 010 68 20	MERCEDES-BENZ	50 003 419	MERCEDES-BENZ	69 (→ 521)
A 611 050 00 01	MERCEDES-BENZ	50 006 375	MERCEDES-BENZ	68 (→ 521), 69 (→ 521)
A 611 050 00 25	MERCEDES-BENZ	50 006 424	MERCEDES-BENZ	56 (→ 515), ... , 75 (→ 524)
A 611 050 01 01	MERCEDES-BENZ	20100361100	MERCEDES-BENZ	68 (→ 521), ... , 74 (→ 524)
A 611 050 01 27	MERCEDES-BENZ	261103	MERCEDES-BENZ	68 (→ 520), ... , 71 (→ 522)
A 611 050 02 25	MERCEDES-BENZ	50 006 424	MERCEDES-BENZ	56 (→ 515), ... , 75 (→ 524)
A 611 050 08 01	MERCEDES-BENZ	50 006 375	MERCEDES-BENZ	68 (→ 521), 69 (→ 521)
A 611 050 18 01	MERCEDES-BENZ	20100361100	MERCEDES-BENZ	68 (→ 521), ... , 74 (→ 524)
A 611 053 01 01	MERCEDES-BENZ	261102	MERCEDES-BENZ	68 (→ 520), ... , 71 (→ 522)
A 611 053 01 05	MERCEDES-BENZ	261103	MERCEDES-BENZ	68 (→ 520), ... , 71 (→ 522)
A 611 053 03 29	MERCEDES-BENZ	81-26182	MERCEDES-BENZ	56 (→ 515), ... , 75 (→ 524)
A 611 053 04 01	MERCEDES-BENZ	261102	MERCEDES-BENZ	68 (→ 520), ... , 71 (→ 522)
A 611 053 15 29	MERCEDES-BENZ	81-2602	MERCEDES-BENZ	59 (→ 516), ... , 106 (→ 539)
A 612 010 10 20	MERCEDES-BENZ	50 003 125	MERCEDES-BENZ	71 (→ 522)
A 612 010 14 20	MERCEDES-BENZ	50 003 125	MERCEDES-BENZ	71 (→ 522)
A 612 010 20 20	MERCEDES-BENZ	50 003 125	MERCEDES-BENZ	71 (→ 522)
A 612 010 32 20	MERCEDES-BENZ	50 003 125	MERCEDES-BENZ	71 (→ 522)
A 612 010 35 20	MERCEDES-BENZ	50 003 125	MERCEDES-BENZ	71 (→ 522)
A 615 053 00 01	MERCEDES-BENZ	2641	MERCEDES-BENZ	59 (→ 516), 103 (→ 538)
A 615 053 01 01	MERCEDES-BENZ	2641	MERCEDES-BENZ	59 (→ 516), 103 (→ 538)
A 615 053 04 05	MERCEDES-BENZ	261118	MERCEDES-BENZ	59 (→ 516), 103 (→ 538)
A 615 053 05 01	MERCEDES-BENZ	2641	MERCEDES-BENZ	59 (→ 516), 103 (→ 538)
A 615 053 07 05	MERCEDES-BENZ	261118	MERCEDES-BENZ	59 (→ 516), 103 (→ 538)
A 616 050 00 27	MERCEDES-BENZ	261117	MERCEDES-BENZ	102 (→ 537), 106 (→ 539)
A 616 050 01 27	MERCEDES-BENZ	261117	MERCEDES-BENZ	102 (→ 537), 106 (→ 539)
A 616 050 05 27	MERCEDES-BENZ	261117	MERCEDES-BENZ	102 (→ 537), 106 (→ 539)
A 616 053 03 01	MERCEDES-BENZ	2605	MERCEDES-BENZ	102 (→ 537), 106 (→ 539)



# ALPHANUMERICAL LIST

Reference	Item No.	Pos (→  )		
A 616 053 03 29	MERCEDES-BENZ	81-2602	MERCEDES-BENZ	59 (→ 516), ... , 106 (→ 539)
A 616 053 03 30	MERCEDES-BENZ	81-2604	MERCEDES-BENZ	59 (→ 516), ... , 106 (→ 539)
A 616 053 04 01	MERCEDES-BENZ	2605	MERCEDES-BENZ	102 (→ 537), 106 (→ 539)
A 617 050 00 27	MERCEDES-BENZ	261117	MERCEDES-BENZ	102 (→ 537), 106 (→ 539)
A 621 053 36 30	MERCEDES-BENZ	81-2604	MERCEDES-BENZ	59 (→ 516), ... , 106 (→ 539)
A 626 050 04 00	MERCEDES-BENZ	50 007 711	MERCEDES-BENZ	13 (→ 500)
A 626 050 05 00	MERCEDES-BENZ	539044	MERCEDES-BENZ	13 (→ 500)
A 626 050 08 00	MERCEDES-BENZ	539045	MERCEDES-BENZ	13 (→ 500)
A 626 050 09 00	MERCEDES-BENZ	539017	MERCEDES-BENZ	6 (→ 498)
A 628 053 00 01	MERCEDES-BENZ	261124	MERCEDES-BENZ	56 (→ 515), ... , 75 (→ 524)
A 628 053 00 05	MERCEDES-BENZ	261125	MERCEDES-BENZ	56 (→ 515), ... , 75 (→ 524)
A 636 050 00 27	MERCEDES-BENZ	2656	MERCEDES-BENZ	3 (→ 497), 5 (→ 498)
A 636 053 01 01	MERCEDES-BENZ	2664	MERCEDES-BENZ	3 (→ 497), 5 (→ 498)
A 636 053 03 01	MERCEDES-BENZ	2691	MERCEDES-BENZ	3 (→ 497), 5 (→ 498)
A 636 053 03 29	MERCEDES-BENZ	81-2624	MERCEDES-BENZ	3 (→ 497), 5 (→ 498)
A 636 053 03 30	MERCEDES-BENZ	81-2612	MERCEDES-BENZ	3 (→ 497), 5 (→ 498)
A 636 053 12 29	MERCEDES-BENZ	81-2658	MERCEDES-BENZ	3 (→ 497), 5 (→ 498)
A 636 053 20 30	MERCEDES-BENZ	81-1662	MERCEDES-BENZ	3 (→ 497), 5 (→ 498)
A 642 050 00 80	MERCEDES-BENZ	50 006 432	MERCEDES-BENZ	17 (→ 501), ... , 237 (→ 615)
A 642 050 01 80	MERCEDES-BENZ	50 006 432	MERCEDES-BENZ	17 (→ 501), ... , 237 (→ 615)
A 642 050 05 27	MERCEDES-BENZ	261127	MERCEDES-BENZ	33 (→ 506), ... , 43 (→ 511)
A 642 050 07 27	MERCEDES-BENZ	261127	MERCEDES-BENZ	33 (→ 506), ... , 43 (→ 511)
A 642 050 08 27	MERCEDES-BENZ	261127	MERCEDES-BENZ	33 (→ 506), ... , 43 (→ 511)
A 642 050 28 01	MERCEDES-BENZ	50 007 693	MERCEDES-BENZ	34 (→ 506), ... , 46 (→ 512)
A 642 050 35 01	MERCEDES-BENZ	50 007 695	MERCEDES-BENZ	34 (→ 506), ... , 42 (→ 510)
A 642 050 46 01	MERCEDES-BENZ	50 007 694	MERCEDES-BENZ	34 (→ 506), ... , 46 (→ 512)
A 642 053 04 01	MERCEDES-BENZ	261126	MERCEDES-BENZ	33 (→ 506), ... , 43 (→ 511)
A 646 010 06 20	MERCEDES-BENZ	50 003 122	MERCEDES-BENZ	73 (→ 523), 75 (→ 524)
A 646 010 10 20	MERCEDES-BENZ	50 003 122	MERCEDES-BENZ	73 (→ 523), 75 (→ 524)
A 646 010 14 20	MERCEDES-BENZ	50 003 122	MERCEDES-BENZ	73 (→ 523), 75 (→ 524)
A 646 053 00 01	MERCEDES-BENZ	261124	MERCEDES-BENZ	56 (→ 515), ... , 75 (→ 524)
A 646 053 01 82	MERCEDES-BENZ	81-1660	MERCEDES-BENZ	3 (→ 497), 5 (→ 498)
A 651 010 11 20	MERCEDES-BENZ	50 003 126	MERCEDES-BENZ	36 (→ 508)
A 651 010 27 20	MERCEDES-BENZ	50 003 126	MERCEDES-BENZ	36 (→ 508)
A 651 010 84 18	MERCEDES-BENZ	50 003 126	MERCEDES-BENZ	36 (→ 508)
A 651 050 00 33	MERCEDES-BENZ	50 007 641	MERCEDES-BENZ	36 (→ 508), ... , 45 (→ 512)
A 651 050 00 80	MERCEDES-BENZ	50 007 640	MERCEDES-BENZ	36 (→ 508), ... , 45 (→ 512)
A 651 050 01 27	MERCEDES-BENZ	261141	MERCEDES-BENZ	36 (→ 507), ... , 45 (→ 511)
A 651 050 02 00	MERCEDES-BENZ	50 007 671	MERCEDES-BENZ	36 (→ 507), ... , 45 (→ 511)
A 651 050 03 00	MERCEDES-BENZ	50 007 672	MERCEDES-BENZ	36 (→ 507), ... , 45 (→ 511)
A 651 050 06 00	MERCEDES-BENZ	50 007 696	MERCEDES-BENZ	38 (→ 509)
A 651 050 09 01	MERCEDES-BENZ	50 007 672	MERCEDES-BENZ	36 (→ 507), ... , 45 (→ 511)
A 651 050 10 01	MERCEDES-BENZ	50 007 671	MERCEDES-BENZ	36 (→ 507), ... , 45 (→ 511)
A 651 050 13 01	MERCEDES-BENZ	50 007 697	MERCEDES-BENZ	38 (→ 509)
A 651 053 00 01	MERCEDES-BENZ	2641	MERCEDES-BENZ	59 (→ 516), 103 (→ 538)
A 651 053 01 01	MERCEDES-BENZ	261140	MERCEDES-BENZ	36 (→ 507), ... , 45 (→ 511)
A 654 050 10 00	MERCEDES-BENZ	261153	MERCEDES-BENZ	27 (→ 504)
A 654 050 40 00	MERCEDES-BENZ	269001	MERCEDES-BENZ	8 (→ 498)
A 654 053 02 00	MERCEDES-BENZ	261152	MERCEDES-BENZ	27 (→ 504)
A 654 053 03 00	MERCEDES-BENZ	269000	MERCEDES-BENZ	8 (→ 498)
A 668 053 02 29	MERCEDES-BENZ	81-16108	MERCEDES-BENZ	12 (→ 500)
A 668 053 02 30	MERCEDES-BENZ	81-16109	MERCEDES-BENZ	12 (→ 500)
A 904 050 04 01	MERCEDES-BENZ	20100390400	MERCEDES-BENZ	240 (→ 617), ... , 298 (→ 654)
A 904 050 09 01	MERCEDES-BENZ	20100390400	MERCEDES-BENZ	240 (→ 617), ... , 298 (→ 654)
A 904 050 40 01	MERCEDES-BENZ	20100390400	MERCEDES-BENZ	240 (→ 617), ... , 298 (→ 654)
A 906 010 59 21	MERCEDES-BENZ	20080390602	MERCEDES-BENZ	238 (→ 616), ... , 311 (→ 662)
A 906 010 72 21	MERCEDES-BENZ	20080390602	MERCEDES-BENZ	238 (→ 616), ... , 311 (→ 662)
A 906 016 07 91	MERCEDES-BENZ	50 009 053	MERCEDES-BENZ	238 (→ 615), ... , 308 (→ 660)
A 906 050 02 26	MERCEDES-BENZ	16200	MERCEDES-BENZ	238 (→ 615), ... , 308 (→ 660)
A 906 050 03 26	MERCEDES-BENZ	160056	MERCEDES-BENZ	238 (→ 615), ... , 313 (→ 662)
A 906 050 03 27	MERCEDES-BENZ	160057	MERCEDES-BENZ	238 (→ 615), ... , 310 (→ 661)
A 906 050 06 26	MERCEDES-BENZ	160056	MERCEDES-BENZ	238 (→ 615), ... , 313 (→ 662)
A 906 050 06 27	MERCEDES-BENZ	160057	MERCEDES-BENZ	238 (→ 615), ... , 310 (→ 661)
A 906 050 07 26	MERCEDES-BENZ	160056	MERCEDES-BENZ	238 (→ 615), ... , 313 (→ 662)
A 906 050 07 27	MERCEDES-BENZ	160057	MERCEDES-BENZ	238 (→ 615), ... , 310 (→ 661)

Reference	Item No.	Pos (→  )		
A 906 050 08 27	MERCEDES-BENZ	16210	MERCEDES-BENZ	238 (→ 615), ... , 313 (→ 662)
A 906 050 09 01	MERCEDES-BENZ	20100390600	MERCEDES-BENZ	241 (→ 618), ... , 311 (→ 662)
A 906 050 09 27	MERCEDES-BENZ	16210	MERCEDES-BENZ	238 (→ 615), ... , 313 (→ 662)
A 906 050 14 01	MERCEDES-BENZ	20100390600	MERCEDES-BENZ	241 (→ 618), ... , 311 (→ 662)
A 906 050 26 01	MERCEDES-BENZ	20100390601	MERCEDES-BENZ	238 (→ 616), ... , 311 (→ 662)
A 906 050 32 01	MERCEDES-BENZ	20100390605	MERCEDES-BENZ	238 (→ 616), ... , 308 (→ 660)
A 906 050 40 01	MERCEDES-BENZ	20100390605	MERCEDES-BENZ	238 (→ 616), ... , 308 (→ 660)
A 906 050 42 01	MERCEDES-BENZ	20100390600	MERCEDES-BENZ	241 (→ 618), ... , 311 (→ 662)
A 906 053 01 29	MERCEDES-BENZ	81-16105	MERCEDES-BENZ	238 (→ 616), ... , 313 (→ 662)
A 906 053 01 30	MERCEDES-BENZ	81-16107	MERCEDES-BENZ	238 (→ 616), ... , 313 (→ 662)
A 906 053 01 31	MERCEDES-BENZ	92-16165	MERCEDES-BENZ	238 (→ 616), ... , 313 (→ 662)
A 906 053 01 32	MERCEDES-BENZ	92-16166	MERCEDES-BENZ	238 (→ 616), ... , 313 (→ 662)
A 906 053 02 31	MERCEDES-BENZ	92-16159	MERCEDES-BENZ	238 (→ 616), ... , 313 (→ 662)
A 906 053 02 32	MERCEDES-BENZ	92-16160	MERCEDES-BENZ	238 (→ 616), ... , 313 (→ 662)
A 906 053 05 29	MERCEDES-BENZ	81-16107	MERCEDES-BENZ	238 (→ 616), ... , 313 (→ 662)
A 906 053 12 32	MERCEDES-BENZ	92-16166	MERCEDES-BENZ	238 (→ 616), ... , 313 (→ 662)
A 906 053 14 32	MERCEDES-BENZ	92-16160	MERCEDES-BENZ	238 (→ 616), ... , 313 (→ 662)
A 906 053 16 32	MERCEDES-BENZ	92-16167	MERCEDES-BENZ	238 (→ 616), ... , 313 (→ 662)
A 906 054 07 01	MERCEDES-BENZ	20100390660	MERCEDES-BENZ	238 (→ 616), ... , 314 (→ 663)
A 906 054 10 01	MERCEDES-BENZ	20100390660	MERCEDES-BENZ	238 (→ 616), ... , 314 (→ 663)
A 934 050 00 01	MERCEDES-BENZ	20100393400	MERCEDES-BENZ	317 (→ 665), 320 (→ 665)
A 936 050 00 26	MERCEDES-BENZ	16213	MERCEDES-BENZ	316 (→ 664), ... , 318 (→ 665)
A 936 050 00 27	MERCEDES-BENZ	16215	MERCEDES-BENZ	316 (→ 664), ... , 318 (→ 665)
A 936 050 01 26	MERCEDES-BENZ	16213	MERCEDES-BENZ	316 (→ 664), ... , 318 (→ 665)
A 936 050 10 01	MERCEDES-BENZ	20100393600	MERCEDES-BENZ	316 (→ 664), 319 (→ 665)
AV6Q 6505 AA	FORD	539047	FORD	11 (→ 295), ... , 26 (→ 301)
AV6Q 6507 AA	FORD	539046	FORD	11 (→ 295), ... , 26 (→ 301)
BG9Q6505AB	FORD	539051	FORD	90 (→ 319), 97 (→ 323)
BK2Q 6505 BA	FORD	181019	FORD	90 (→ 319), ... , 128 (→ 339)
BK2Q 6505 BB	FORD	181019	FORD	90 (→ 319), ... , 128 (→ 339)
BK2Q 6507 BB	FORD	181018	FORD	90 (→ 319), ... , 128 (→ 339)
BK2Q-6A273-AB	FORD	50 007 686	FORD	111 (→ 330), 112 (→ 331)
BK2Q-6K551-BC	FORD	50 007 653	FORD	107 (→ 327), ... , 127 (→ 338)
BK3Q-6A270-AA	FORD	50 007 687	FORD	111 (→ 330), 112 (→ 331)
BS51 6250 AA	FORD	50 007 799	FORD	1 (→ 292), 2 (→ 292)
BS51 6250 BA	FORD	50 007 800	FORD	1 (→ 292), 2 (→ 292)
C5NE 6505 A	FORD	105-34049	FORD	150 (→ 344), ... , 155 (→ 345)
C5NE 6507 A	FORD	105-34048	FORD	150 (→ 344), ... , 155 (→ 345)
CAM5821	ROVER	81-88005	ROVER	14 (→ 1024), ... , 16 (→ 1025)
CM5E-6C525-DD	FORD	50 007 779	FORD	94 (→ 321)
CM5G 6505 EA	FORD	181118	FORD	8 (→ 294), 9 (→ 294)
CM5G 6507 CB	FORD	181120	FORD	8 (→ 294), 9 (→ 294)
CM5G-6C525-DC	FORD	50 007 778	FORD	9 (→ 294)
CP40239	VOLKSWAGEN	50 006 415	VOLKSWAGEN	2 (→ 1125), ... , 251 (→ 1222)
D3NN6507A	FORD	105-34048	FORD	150 (→ 344), ... , 155 (→ 345)
E1ADDN 6510A	FORD	81-18103	FORD	146 (→ 344), ... , 154 (→ 345)
EIADDN 6510A	FORD	81-18103	FORD	146 (→ 344), ... , 154 (→ 345)
F5RZ 6500 BA	FORD	50 007 597	FORD	28 (→ 301), ... , 57 (→ 310)
HG9Q-6E262-CC	FORD	50 007 780	FORD	80 (→ 316), 81 (→ 316)
HG9Q-6E262-CD	FORD	50 007 780	FORD	80 (→ 316), 81 (→ 316)
LGH10029	ROVER	105-35474	ROVER	5 (→ 1023)
LGH100820	ROVER	105-35475	ROVER	5 (→ 1023)
LGH101190	ROVER	105-35475	ROVER	5 (→ 1023)
LGH101450	ROVER	111113	ROVER	13 (→ 1024)
LGN10005	ROVER	KK-8H	ROVER	11 (→ 1024)
WAM 1452	ROVER	81-88000	ROVER	3 (→ 1023), ... , 10 (→ 1024)
XM21 650 BA	FORD	50 006 418	FORD	46 (→ 307), 47 (→ 307)
XM21-6251-AA	FORD	50 006 304	FORD	46 (→ 307)
XS4Q 6250 AC	FORD	50 007 029	FORD	73 (→ 314)
XS4Q 6507 AB	FORD	181014	FORD	70 (→ 313), ... , 74 (→ 315)
XS6G 6505 B2A	FORD	181008	FORD	40 (→ 304)
XS7E 6505 D2D	FORD	181021	FORD	59 (→ 310), 83 (→ 316)
XS7E 6507 D2A	FORD	181012	FORD	59 (→ 310), 82 (→ 316)
XS7Q 6505 A2B	FORD	181019	FORD	90 (→ 319), ... , 128 (→ 339)
XS7Q 6507 A1B	FORD	181018	FORD	90 (→ 319), ... , 128 (→ 339)

# ALPHANUMERICAL LIST

Reference	Item No.	Pos ( →  )
XS7Q 6507 A1C FORD	181018	FORD 90 (→ 319), ... , 128 (→ 339)
XS7Q 6507 A2B FORD	181018	FORD 90 (→ 319), ... , 128 (→ 339)
XS7Q 6507 A2C FORD	181018	FORD 90 (→ 319), ... , 128 (→ 339)
XS7Q6510AC FORD	81-18112	FORD 90 (→ 319), ... , 128 (→ 339)
XS7Q6529A1C FORD	50 007 610	FORD 104 (→ 325), 105 (→ 325)
XS7Q6K528A1C FORD	50 007 611	FORD 104 (→ 325), 105 (→ 325)
YC1Q 6507 A1B FORD	181016	FORD 121 (→ 334), ... , 127 (→ 338)
YC1Q 6507 A2B FORD	181016	FORD 121 (→ 334), ... , 127 (→ 338)
YC1Q6529A1D FORD	50 007 609	FORD 121 (→ 334), 124 (→ 336)
YC1Q6K528A1D FORD	50 007 608	FORD 121 (→ 334), 124 (→ 336)



# Voraussetzungen für Kundenretouren (keine Reklamationen)

Lieber Geschäftspartner,

für Retouren von Waren gibt es vielerlei Gründe. Sollten Sie etwas zurückschicken, bitten wir Sie folgende Hinweise zu beachten.

## Voraussetzungen für Retouren verkaufsfähiger Ware:

- Die Verpackung muss unbeschädigt, nicht beschrieben oder beklebt und sauber sein.
- Die Ware muss original verpackt sein.
- Bitte informieren Sie vor jeder Retoure Ihren Gebietsverkaufsleiter.
- Sie erhalten von Ihrem Gebietsverkaufsleiter eine Retourenauftragsnummer. Bitte geben Sie diese Nummer bei Ihrer Rücksendung an.
- Fügen Sie bei Ihrer Retoure pro Artikelposition eine Kopie der Rechnung bei.
- Das Rechnungsdatum darf nicht länger als 3 Jahre zurück liegen.

Die Abzüge vom Warenwert sind abhängig vom Rechnungsdatum und lauten wie folgt:

a) Rechnungsdatum nicht älter als	3 Monate	0%
b) Rechnungsdatum	3–12 Monate	20%
c) Rechnungsdatum	13–24 Monate	30%
d) Rechnungsdatum	25–36 Monate	40%

Wir behalten uns vor, durch ungeplante Kontrollprozesse oder sonstige Aufwände, die daraus entstandenen Kosten entsprechend in Abzug zu bringen. Nähere Informationen hierzu erhalten Sie von Ihrem Gebietsverkaufsleiter.

## Grundsätzlich nicht zurückgenommen werden können:

- Waren aus Sonderverkäufen
- landesspezifische Waren
- Abverkaufsprodukte
- Produkte, die durch andere Artikel ersetzt wurden
- nicht mit uns abgestimmte Retouren
- Waren in unverkäuflichem Zustand (siehe oben)
- Kataloge und andere Drucksachen, CD/DVD, Werbematerial

**Bitte stimmen Sie das weitere Vorgehen vor der Rücklieferung mit uns ab.**

Vielen Dank.

Ihr Vertriebsteam

# Requirements for customer returns (not claims)

Dear business partner,

There are many reasons why goods may need to be returned. Should you need to return goods to us where no claims apply, please observe the following instructions.

## Requirements for returning saleable goods:

- The packaging must be clean and free from damage, writing and labels.
- The goods must be in their original packaging.
- Please inform your area sales manager before returning any goods.
- Your area sales manager will provide you with a returns order number.  
Please include the number on your return.
- A copy of the invoice must be included with your return for each item position.
- The invoice must be dated within the last three years.

The deductions from the value of the goods depend on the invoice date and are as follows:

a) Invoice date not more than 3 months ago	0%
b) Invoice date 3-12 months	20%
c) Invoice date 13-24 months	30%
d) Invoice date 25-36 months	40%

We reserve the right to apply deductions for costs incurred as a result of inspections, re-storage processes and any other unplanned expenditure. Please contact your area sales manager for more information.

## The following can not be returned:

- Goods from special sales
- Country-specific goods
- Sale products
- Products that have been replaced with other articles
- Returns that have not been agreed with us
- Goods in an unsaleable condition (see above)
- Catalogues and other printed items, CDs/DVDs, advertising material

**Please agree the further procedure with us before returning the goods.**

Thank you.

Your sales team

# Vorgehensweise bei Reklamationen

## Sehr geehrter Motorservice Partner,

für eine schnelle und reibungslose Reklamationsbearbeitung bitten wir um die Beachtung der nachfolgenden Punkte.

### Voraussetzungen für Reklamationen

Der Motorservice Handelspartner garantiert gegenüber Motorservice, dass die Voraussetzungen für eine Reklamation erfüllt sind. Der Handelspartner von Motorservice hat im Vorfeld geprüft, ob das reklamierte Teil aus dem Motorservice Lieferprogramm stammt. Ferner ist anhand von Lieferscheinen oder Rechnungen zu prüfen und zu belegen, dass seit der Lieferung des Ersatzteils weniger als 12 Monate vergangen sind. Der Handelsweg muss eingehalten werden.

### Einreichung von Reklamationen

Wenn die Teile über den Motorservice OnlineShop bestellt wurden, erfolgt die Einreichung der Reklamation direkt über den OnlineShop. Bitte wählen Sie hierzu im Menü „Mein Konto“ den Eintrag „Reklamationen“ und geben Sie die Daten in das bereitgestellte Webformular ein. Für alle übrigen Reklamationen benutzen Sie bitte das nachfolgende Formular. Bitte beachten Sie, dass die für die Bearbeitung notwendigen Pflichtdatenfelder vollständig ausgefüllt sind. Der Umfang der Reklamation (Schadenshöhe) muss stets vollständig angegeben werden. Darüber hinaus sind wir auch umgehend über ggf. entstandene Personenschäden zu informieren. Werden Reparatur- oder Folgekosten geltend gemacht, müssen die entsprechenden Rechnungen als Kopie beigefügt werden. Nachträglich eingereichte Kostenansprüche, die nach unserer Diagnose oder Ergebnismitteilung eingehen, können nicht mehr anerkannt werden.

### Rücksendung von Reklamationsteilen

Senden Sie Reklamationsteile nur dann zurück, wenn diese explizit von Motorservice zurückgefordert werden. Ob und welche Teile zurückgesendet werden müssen, teilen wir Ihnen nach Eingang der Reklamationsmeldung mit. Produkte, die aus mehreren Teilen bestehen, müssen stets in dem Umfang zurückgesandt werden, wie diese bezogen wurden. Wir behalten uns vor, Teile die ebenfalls beschädigt wurden bzw. zur Schadensentstehung beigetragen haben, anzufordern oder nachzufordern, auch wenn diese nicht zum Lieferprogramm von Motorservice gehören.

Reklamationsteile sind für Motorservice kostenfrei einzusenden. Wenn in einer Lieferung Teile von unterschiedlichen Reklamationen enthalten sind, müssen diese jeweils separat verpackt und gekennzeichnet werden. Teile aus Reklamationen die über das Online Reklamationsmanagement eingereicht werden, müssen für den Rückversand mit dem von der Webanwendung bereit gestellten Rücksendetikett versehen werden. Bereits benutzte Teile müssen frei von Öl und sonstigen Verunreinigungen sein. Der Handelspartner muss sicherstellen, dass die Teile ordnungsgemäß verpackt sind und beim Transport nicht beschädigt werden können. Die Teile sind zweckmäßig in einer Originalverpackung unter Einhaltung größtmöglicher Sorgfalt einzusenden. Der Rücktransport erfolgt auf Risiko und Gefahr des Handelspartners. Bei einem Teilerückversand außerhalb der europäischen Union sind die zolltechnischen Bestimmungen (z. B. Mitsendung einer Proformarechnung, Mitteilung der ursprünglichen Handelsrechnungsnummer, Teiledeklaration) in jedem Fall einzuhalten.

#### Adressen für den Teilerückversand :

PIERBURG Schadensteile:  
**MS Motorservice International GmbH**  
**Hamburger Straße 15**  
**41540 Dormagen, Germany**

Alle Neuteilreklamationen und alle sonstigen Schadensteile  
**MS Motorservice International GmbH**  
**Wilhelm-Maybach-Straße 14-18**  
**74196 Neuenstadt, Germany**

### Zerstörende Bauteilprüfungen

Im Rahmen der Reklamationsbearbeitung kann es nötig sein, Teile oder Baugruppen für eine Diagnose oder Werkstoffprüfung zu zerlegen oder einer zerstörenden Prüfung zu unterziehen. Sofern Sie sich bei der Einreichung der Reklamation schriftlich einverstanden erklärt haben, übernehmen wir für die bei der Analyse entstandenen Beschädigungen keine Haftung.

### Sonstiges

Teile sind nur dann reklamationstauglich, wenn diese bestimmungsgemäß eingesetzt bzw. verwendet wurden. Modifizierte Teile, bereits zerlegte Komponenten und Teile, an denen Reparaturversuche unternommen wurden, sind nicht reklamationstauglich. Teile aus abgelehnten Reklamationen werden verschrottet, sofern diese nicht explizit zurückgefordert werden. Im Rahmen der Gewährleistung erstattete Teile gehen in das Eigentum von Motorservice über. Aus organisatorischen Gründen kann die Reklamationsabwicklung ausschließlich in den Sprachen Deutsch oder Englisch erfolgen.

# Reklamationsformular

## Adressangaben:

Ihre Schadensnummer (nicht Artikelnummer):

Motorservice Kundennummer:

Teilebezeichnung\*:

Firmenname und Adresse\*:

Artikelnummer\*:

Anzahl Reklamationsteile\*:

Kaufdatum\*:

Rechnungsnummer:

Name Ihres Kunden (Werkstatt, Motoreninstandsetzer):

## Neuteilerekklamation (nur ausfüllen bei unbenutzten Teilen):

 Beschädigung

 Produktfehler

 Einbauproblem

 Verpackungsfehler

 Transportschaden

 Falsche Spezifikation

 Korrosion/Schmutz

 Sonstiges

## Schadensfall (nur ausfüllen, wenn die Teile im Betrieb beschädigt wurden):

Kraftstoffart\*:

 Diesel

 Benzin

 Alkohol

 Gas (LPG, CNG, ...)

Applikation\*:

 Straßenfahrzeug

 Industrieanwendung

 Marineanwendung

 Agrarfahrzeug

Motorenhersteller\*:

Motorentyp/Motornummer\*:

Schlüsselnummer (zu 2 und 3):

Baujahr/Erstzulassung\*:

Teile-Einbaudatum\*:

+

km-Stand/Betriebsstunden\*:

Schadensdatum\*:

+

km-Stand/Betriebsstunden\*:

Schadensbeschreibung\*: (fügen Sie ggf. eine Anlage bei, falls der Platz nicht ausreicht)

Schadensumfang/Forderung\*:

 nur Teileersatz

Schadenssumme in Euro\*:

 Teileersatz inklusive Reparaturkosten (bitte Reparaturrechnung beifügen)

 Bitte senden Sie die Teile im Fall einer Ablehnung wieder zurück.

 Ich bin damit einverstanden, dass die Teile im Zuge der Untersuchung bei Bedarf zerlegt, geöffnet oder einer zerstörenden Prüfung unterzogen werden werden.

Ort/Datum\*:

Sachbearbeiter\*:

# Procedure in case of claims

**Dear Motorservice Partner,**

**In order to ensure fast and trouble-free processing of claims, please observe the following points.**

## **Prerequisites for claims**

The Motorservice trading partner guarantees Motorservice that the prerequisites for a claim are met. The Motorservice trading partner has already verified whether the part subject to the claim is part of the Motorservice product range. Furthermore, it is to be checked and proven based on delivery notes or invoices that less than 12 months have passed since delivery of the spare part. The trade route must be adhered to.

## **Submitting claims**

If the parts were ordered via the Motorservice OnlineShop, claims must be submitted directly via the OnlineShop. To do this, please select the "Claims" entry in the "My account" menu and enter the data in the web form provided. For all other claims, please use the following form. Please ensure that the compulsory fields required to process the claim are filled out completely. The scope of the claim (amount of loss) must always be fully specified. Furthermore, we need to be notified immediately about any resulting personal injury. If repair or follow-up costs are claimed, copies of the respective invoices must be enclosed. Claims for costs that were handed in after our diagnostics or communication of results cannot be accepted.

## **Returning claim parts**

Claim parts should only be returned if explicitly requested by Motorservice. We will inform you whether and which parts have to be returned following receipt of your claim. Products made up of several parts must always be returned as a whole in the same scope as they were purchased. We reserve the right to request parts that were also damaged or that contributed to the damage being caused, even if they are not part of the Motorservice product range.

Claim parts must be sent in without incurring a charge for Motorservice. If a delivery includes parts relating to different claims, they must each be packaged and labelled separately. For parts from claims submitted via the online claims management, the returns label provided by the web application must be used for the return. Already used parts must be free from oil and other impurities. The trading partner must ensure that the parts are packaged properly and cannot be damaged during transport. The parts must be sent in appropriate original packaging with the greatest possible care. The items are returned at the trade partner's own risk and peril. When returning parts from outside the European Union, customs agreements (e.g. sending of a pro-forma invoice, communication of the original commercial invoice no., part declaration) must be adhered to at all times.

## **Destructive component testing**

When processing claims, it may be necessary to dismantle parts or assembly groups for diagnostics or material inspection, or to subject them to destructive testing. If you gave your consent in writing when submitting the claim, we can accept no liability for any damage that may occur during the analysis.

## **Other**

Parts can only be claimed if they were deployed or used for their intended purpose. Modified parts, components and parts already taken apart in the course of repair attempts cannot be claimed. Parts from rejected claims will be scrapped unless an explicit request has been made for them to be returned. Parts refunded within the scope of the warranty become the property of Motorservice. For organisational reasons, only German or English can be used when dealing with claims.

### **Addresses for returning parts:**

PIERBURG damaged parts:

**MS Motorservice International GmbH  
Hamburger Straße 15  
41540 Dormagen, Germany**

All claims relating to new parts and all other damaged parts

**MS Motorservice International GmbH  
Wilhelm-Maybach-Straße 14-18  
74196 Neuenstadt, Germany**

# Claims form

**Address details:**
**Your claim number (not item number):**

**Motorservice customer number:**

**Part designation\*:**

**Company name and address\*:**

**Item number\*:**

**Number of faulty parts\*:**

**Date of purchase\*:**

**Invoice number:**

**Name of your customer (repair shop, engine reconditioner):**

 **New part return (only to be completed for unused parts):**
 **Damage**
 **Product defect**
 **Installation problem**
 **Packaging fault**
 **Damage in transit**
 **Wrong specification**
 **Corrosion/dirt**
 **Other**
 **Event of damage (only to be completed if parts were damaged during operation):**
**Type of fuel\*:**
 **Diesel**
 **Petrol**
 **Alcohol**
 **Gas (LPG, CNG, ...)**
**Application\*:**
 **Road vehicle**
 **Industrial application**
 **Marine application**
 **Agricultural vehicle**
**Engine manufacturer\*:**

**Engine type/engine number\*:**

**Key number (for 2 and 3):**

**Model year/initial registration\*:**

**Part date of installation\*:**

**km status/hours of operation\*:**

+

**Damage date\*:**

+

**km status/hours of operation\*:**

**Damage description\*:** (if required, add an attachment if not enough space is available)

**Extent of damage/claim\*:**
 **only part replacement**
**Total claim in Euro\*:**

 **Part replacement incl. repair costs (please enclose repair invoice)**
 **In case of refusal, please return the parts.**
 **I agree the parts to be taken apart, opened or submitted to destructive testing within the scope of examination as required.**
**Place/date\*:**
**Case handler\*:**



### 1. Geltungsbereich

**1.1** Die Verkaufs- und Lieferbedingungen der MS Motorservice International GmbH (im Folgenden „Verkäufer“ genannt) gelten ausschließlich. Entgegenstehende oder von diesen Verkaufs- und Lieferbedingungen abweichende Bedingungen des Käufers werden nicht anerkannt, es sei denn, der Verkäufer hat ausdrücklich und schriftlich der Geltung abweichender Bedingungen zugestimmt. Diese Verkaufs- und Lieferbedingungen gelten auch dann, wenn der Verkäufer in Kenntnis entgegenstehender oder von den eigenen Verkaufs- und Lieferbedingungen abweichender Bedingungen des Käufers die Lieferung an den Käufer vorbehaltlos durchführt.

**1.2** Von diesen Verkaufs- und Lieferbedingungen abweichende oder sie ergänzende separate Vereinbarungen zwischen den Parteien gelten vorrangig. Sie werden dort, sofern keine speziellen Regelungen getroffen sind, durch die vorliegenden Verkaufs- und Lieferbedingungen ergänzt. Für den Inhalt derartiger Vereinbarungen ist ein schriftlicher Vertrag bzw. die schriftliche Bestätigung des Verkäufers maßgebend.

**1.3** Die Verkaufs- und Lieferbedingungen gelten auch für alle zukünftigen Geschäfte mit dem Käufer. Durch Bestellung des Käufers, spätestens aber durch Annahme der Ware, werden diese Verkaufs- und Lieferbedingungen vom Käufer anerkannt.

**1.4** Diese Verkaufs- und Lieferbedingungen gelten nur gegenüber Unternehmern.

### 2. Angebot und Auftragsbestätigung

**2.1** Angebote des Verkäufers sind stets unverbindlich. Ist eine Bestellung des Käufers, rechtlich als Angebot zu qualifizieren, gilt diese erst dann als angenommen, wenn sie vom Verkäufer innerhalb von vier Wochen schriftlich bestätigt wird. Spätestens kommt der Vertrag mit Versendung oder der Mitteilung über den Bereitstellungszeitpunkt der bestellten Ware, bei Teillieferung mit Absendung der ersten Lieferung, zustande.

**2.2** Änderungen und sonstige Vereinbarungen sind nur dann verbindlich, wenn sie vom Verkäufer schriftlich bestätigt werden.

**2.3** Die in den Angeboten enthaltenen Unterlagen, Zeichnungen, Gewichtszu- und Maßangaben, Muster etc. sind nur ungefähre Angaben und stellen keine Beschaffenheitsmerkmale dar. Der Verkäufer ist berechtigt, von den Beschreibungen im Angebot abzuweichen, sofern diese Abweichungen nicht grundlegender oder wesentlicher Art sind und der vertragsgemäße Zweck nicht wesentlich eingeschränkt wird.

**2.4** Soweit Waren nach Käuferzeichnungen gefertigt werden, sind die vom Käufer erstellten und vom Verkäufer genehmigten Zeichnungen maßgeblich. Abweichungen von genehmigten Zeichnungen sind besonders zu vereinbaren und etwaige Mehrkosten hierfür sind dem Verkäufer zu vergüten.

### 3. Schutzrechte

**3.1** Der Verkäufer behält sich an allen Abbildungen, Zeichnungen, Kalkulationen und sonstigen Unterlagen das Eigentums- und Urheberrecht vor; sie dürfen ohne vorherige schriftliche Zustimmung des Verkäufers weder für andere als die vom Verkäufer angegebenen Zwecke verwendet noch Dritten zugänglich gemacht werden. Dies gilt insbesondere für solche schriftlichen Unterlagen, die als „vertraulich“, „geheim“ oder ähnlich bezeichnet sind.

**3.2** Der Verkäufer haftet nur für Ansprüche, die sich bei vertragsgemäßer Verwendung der Waren aus der Verletzung von Schutzrechten und Schutzrechtsanmeldungen (Schutzrechte) ergeben, von denen mindestens eines aus der Schutzrechtsfamilie entweder vom Europäischen Patentamt oder in einem der Staaten Bundesrepublik Deutschland, Frankreich, Großbritannien, Österreich, China, Japan oder USA veröffentlicht ist.

**3.3** Erfolgen Lieferungen nach Zeichnungen oder sonstigen Angaben des Käufers und werden hierdurch Schutzrechte Dritter verletzt, stellt der Käufer den Verkäufer im Innenverhältnis von sämtlichen Ansprüchen frei.

### 4. Empfehlungen, Informationen und Auskünfte

Empfehlungen, Informationen und Auskünfte sind unverbindlich, soweit sie sich nicht auf die Ware selbst beziehen.

### 5. Preise

**5.1** Alle Preise sind Nettopreise und gelten „ab Werk“ (Incoterms®2020, „EXW“) ausschließlich Verpackung, Fracht, Porto und Wertsicherung. Die gesetzliche Umsatzsteuer in der jeweils gültigen Höhe wird hinzugerechnet.

**5.2** Etwaiger Mehraufwand, der durch Änderungswünsche entsteht, kann dem Käufer vom Verkäufer in Rechnung gestellt werden.

**5.3** Treten nach Abschluss des Vertrages Ereignisse ein, die die Selbstkosten des Verkäufers beim Einkauf, der Herstellung und/oder dem Versand der Ware verteuern, so ist der Verkäufer zu entsprechender Preiserhöhung berechtigt.

### 6. Zahlungsbedingungen

**6.1** Rechnungen sind innerhalb von 14 Tagen ab Rechnungsdatum ohne Abzug zur Zahlung fällig. Der Verkäufer ist, auch im Rahmen einer laufenden Geschäftsbeziehung, jederzeit berechtigt, eine Lieferung ganz oder teilweise nur gegen Vorkasse durchzuführen. Skonto gilt nur bei ausdrücklicher schriftlicher Vereinbarung.

**6.2** Der Verkäufer ist berechtigt, selbst bei entgegenstehender Zweckbindung des Käufers eine Zahlung zunächst auf die jeweils älteste, nicht titulierte Schuld anzurechnen. Sind bereits Kosten oder Zinsen entstanden, ist der Verkäufer berechtigt, Zahlungen zunächst auf die Kosten, dann auf die Zinsen und zuletzt auf die Hauptleistung anzurechnen.

**6.3** Das Recht zur Aufrechnung steht dem Käufer nur zu, wenn und soweit seine Gegenseiten rechtskräftig festgestellt, unbestritten oder vom Verkäufer schriftlich anerkannt sind. Das Zurückbehaltungsrecht des Käufers ist auf Ansprüche aus dem Vertragsverhältnis beschränkt.

**6.4** Der Verkäufer ist berechtigt, Verzugszinsen in Höhe des jeweils gültigen gesetzlichen Verzugszinssatzes zu verlangen. Das Recht, einen höheren Verzugszins nachzuweisen, bleibt ausdrücklich vorbehalten.

### 7. Lieferung / Lieferzeit / Verzug

**7.1** Lieferfristen und Liefertermine gelten nur dann als verbindlich vereinbart, wenn diese vom Verkäufer ausdrücklich schriftlich zugesagt werden. Der Verkäufer ist an den Liefertermin bzw. die Lieferfrist nicht gebunden, wenn der Käufer seinen Obliegenheiten (Zahlung von Abschlägen, Beibringung erforderlicher Unterlagen, Beistellungen zur Fertigung etc.) nicht rechtzeitig nachkommt. Die Einrede des nichterfüllten Vertrages bleibt vorbehalten.

**7.2** Lieferfristen beginnen frühestens an dem Tag, an dem der Vertrag schriftlich geschlossen wurde und alle technischen Fragen geklärt sind.

**7.3** Bei Änderungswünschen des Käufers ist der Verkäufer von der Einhaltung eines etwaig vereinbarten Liefertermins bzw. der Lieferfrist befreit. Die Parteien werden in diesem Fall einen neuen Liefertermin oder eine neue Lieferfrist vereinbaren.

**7.4** Sofern nichts Abweichendes vereinbart wird, ist der Liefertermin bzw. die Lieferfrist einzuhalten, wenn der Verkäufer die Ware an dem vereinbarten Ort bereitgestellt hat.

**7.5** Wegen Lieferverzögerungen, die nicht auf Vorsatz oder grober Fahrlässigkeit des Verkäufers beruhen, kann der Käufer keine Ansprüche geltend machen. Dies gilt auch bei sonstigen Störungen, insbesondere für Lieferverzögerungen aufgrund von höherer Gewalt, Arbeitskämpfen, Unruhen, Epidemien und/oder Pandemien, Cyberattacken, behördlichen Maßnahmen, Ausbleiben von Zulieferern der Zulieferanten und sonstigen unvorhersehbaren, unabwendbaren und schwerwiegenden Ereignissen. Der vereinbarte Liefertermin bzw. die Lieferfrist verschiebt sich in diesen Fällen entsprechend der Dauer des Lieferhindernisses, der Verkäufer informiert den Käufer hierüber und wird, sofern möglich, einen neuen voraussichtlichen Liefertermin mitteilen. Der Ersatz von entgangenem Gewinn und Schäden aus Betriebsunterbrechung ist auf Vorsatz beschränkt.

**7.6** Kommt der Käufer in Annahmeverzug oder verletzt er sonstige Mitwirkungspflichten, so ist der Verkäufer berechtigt, den insoweit entstandenen Schaden einschließlich etwaiger Mehraufwendungen ersetzt zu verlangen. Der Verkäufer ist darüber hinaus berechtigt, dem Käufer eine angemessene Annahmefrist zu setzen und nach deren fruchtlosem Verstreichen vom Vertrag zurückzutreten und Schadensersatz statt der Leistung zu verlangen.

**7.7** Teillieferungen sind in zumutbarem Umfang zulässig. Insofern sind Ansprüche des Käufers wegen der Teillieferung oder einer verspäteten Lieferung der Restmenge ausgeschlossen.

### 8. Eigentumsvorbehalt

**8.1** Der Verkäufer behält sich das Eigentum an sämtlichen gelieferten Waren bis zum Eingang aller Zahlungen aus der Lieferbeziehung, auch der zukünftig entstehenden Verbindlichkeiten, vor. Bei vertragswidrigem Verhalten, insbesondere bei Zahlungsverzug, ist der Verkäufer berechtigt, die Waren zurückzufordern.

**8.2** Der Käufer ist verpflichtet, die gelieferten Waren pfleglich zu behandeln und während der Dauer des Eigentumsvorbehaltes auf eigene Kosten gegen jede Form des Untergangs zum Kaufpreis zu versichern. Der Verkäufer bleibt berechtigt, die Ware auf Kosten des Käufers selbst zu versichern.

**8.3** Bei Pfändungen oder sonstigen Eingriffen Dritter hat der Käufer den Verkäufer unverzüglich schriftlich zu benachrichtigen, damit dieser Drittwiderspruchsklage oder andere Rechtsmittel erheben kann. Soweit der Dritte die hierdurch entstehenden gerichtlichen und außergerichtlichen Kosten nicht erstattet, haftet hierfür der Käufer.

**8.4** Der Käufer ist berechtigt, die Ware im ordentlichen Geschäftsgang weiter zu verkaufen; er tritt dem Verkäufer jedoch bereits jetzt alle Forderungen in Höhe des Faktura-Endbetrages (einschließlich gesetzlicher Umsatzsteuer) der Forderung ab, die ihm aus der Weiterveräußerung gegen seine Abnehmer oder Dritte erwachsen, und zwar unabhängig davon, ob die Ware ohne oder nach Verarbeitung weiterverkauft wurde. Zur Einziehung dieser Forderung bleibt der Käufer auch nach Auslieferung berechtigt. Die Befugnis des Verkäufers, die Forderung selbst einzuziehen, bleibt davon unberührt.

**8.5** Wird die gelieferte Ware mit anderen, nicht dem Verkäufer gehörenden Gegenständen untrennbar vermischert oder verbunden, so erwirbt der Verkäufer das Miteigentum an der neuen oder verbundenen Sache im Verhältnis des Wertes der gelieferten Ware (Faktura-Endbetrag, einschließlich gesetzlicher Mehrwertsteuer) zu der oder den anderen Gegenständen zum Zeitpunkt der Vermischung oder Verbindung. Der Käufer verwahrt das so entstandene Allein- oder Miteigentum für den Verkäufer.

**8.6** Übersteigt der Wert der gegebenen Sicherheiten die Forderungen des Verkäufers insgesamt um mehr als 20 %, so ist der Verkäufer auf Verlangen des Käufers verpflichtet, die überschüssigen Sicherheiten nach Wahl des Verkäufers freizugeben.

**8.7** Falls und soweit die maßgebliche Rechtsordnung keine Vereinbarung eines Eigentumsvorbehalts zulässt, wird der Käufer den Verkäufer bei Inanspruchnahme von Warenkredit angemessene andere Sicherheiten stellen.

### 9. Versand, Gefahrenübergang

**9.1** Der Versand erfolgt auf Gefahr des Käufers. Die Gefahr geht stets spätestens mit Absendung der Ware, auch wenn weitere Leistungen von dem Verkäufer übernommen werden, auf den Käufer über.

**9.2** Verzögert sich der Versand infolge von Umständen, die der Verkäufer nicht zu vertreten hat, so geht die Gefahr vom Tage der Anzeige der Versandbereitschaft auf den Käufer über. Auf schriftlichen Wunsch des Käufers wird die Sendung von dem Verkäufer gegen Bruch-, Transport-, Feuer- und Wasserschäden auf Kosten des Käufers versichert.

**9.3** Transport- und alle sonstigen Verpackungen nach Maßgabe des Verpackungsgesetzes werden nicht zurückgenommen; ausgenommen sind Paletten. Der Käufer ist verpflichtet, die Entsorgung der Verpackung auf eigene Kosten zu besorgen.

### 10. Fertigungsmittel

**10.1** Soweit der Käufer dem Verkäufer Fertigungsmittel (z.B. Werkzeuge, Formen) zur Verfügung stellt, sind diese dem Verkäufer kostenfrei zuzusenden. Für deren Untergang, Verschlechterung oder unvollständige Rücklieferung und daraus resultierende Schäden haftet der nur bei grober Fahrlässigkeit oder Vorsatz. Dies gilt nicht, soweit gesetzlich zwingend gehaftet wird.

**10.2** Wenn Fertigungsmittel vom Verkäufer im Auftrag des Käufers angefertigt oder beschafft werden, stellt der Verkäufer dem Käufer hierfür die Kosten gesondert in Rechnung. Die Fertigungsmittel bleiben Eigentum des Verkäufers. Zur Herausgabe an den Käufer ist der Verkäufer nicht verpflichtet. Vorstehendes gilt auch für Folgewerkzeuge. Die nachfolgende Regelung in Ziffer 10.3 bleibt hiervon unberührt.

**10.3** Im Falle der Amortisation der Kosten der Fertigungsmittel über den Teilepreis übernimmt der Käufer bei Nichtamortisation eines Werkzeuges die nicht gedeckten Kosten einschließlich der Kosten der sonstigen typengebundenen Einrichtungen. Kosten für Modelle gehen stets in vollem Umfang zu Lasten des Käufers.

**10.4** Vom Verkäufer dem Käufer ausgehändigte Zeichnungen und Unterlagen sowie Vorschläge des Verkäufers für die Gestaltung und zur Herstellung der Ware dürfen an Dritte nicht weitergegeben und können vom Verkäufer jederzeit zurückverlangt werden.

### 11. Sachmängelhaftung / Haftung

**11.1** Der Verkäufer haftet nicht für Schäden, die durch Verletzung von Bedienungs-, Wartungs- und Einbauvorschriften, ungeeignete, nicht bestimmungsgemäße oder unsachgemäße Verwendung, fehlerhafte oder nachlässige Behandlung, natürlicher Verschleiß, falsche Lagerung oder vom Käufer oder Dritten vorgenommene Veränderungen der Ware auftreten. Die Waren dürfen vom Käufer oder Dritten nur durch unterwiesenes Fachpersonal eingebaut werden.

**11.2** Dem Verkäufer steht das Wahlrecht zwischen Nachbesserung und Neulieferung zu. Der Käufer hat dem Verkäufer die beanstandete Ware auf dessen Verlangen zu Untersuchungszwecken zu übergeben. Sofern dem Verkäufer aufgrund eines unberechtigten Mangelbeseitigungsvorlangens des Käufers Kosten entstehen (insbesondere Prüf- und Transportkosten), so kann der Verkäufer Erstattung dieser Kosten verlangen.

**11.3** Die zum Zwecke der Nacherfüllung erforderlichen Aufwendungen werden nicht vom Verkäufer getragen, soweit die Aufwendungen sich dadurch erhöhen, dass die Ware nach der Lieferung an einen anderen Ort als den ursprünglichen Lieferort verbracht worden ist.

**11.4** Erfolgt die Inanspruchnahme des Verkäufers durch den Käufer im Wege des Rückgriffs, nachdem der Käufer selbst wegen Mängel von seinem Kunden in Anspruch genommen worden ist, so gilt für die Rechtsdurchsetzung § 445a BGB.

**11.5** Ansprüche aus Sachmängelhaftung verjähren in einem Jahr ab Übergabe der Ware, es sei denn, die Sachmängelhaftungsansprüche beruhen auf einer grob fahrlässigen oder vorsätzlichen Pflichtverletzung des Verkäufers oder seines Erfüllungsgehilfen oder auf einer Verletzung von Leben, Körper oder Gesundheit. Bei Mängelgewährleistungsansprüchen, die der Käufer im Wege des Rückgriffs gem. § 445a BGB gegen den Verkäufer geltend macht, gilt uneingeschränkt die Verjährungsregelung des § 445b BGB.

**11.6** Der Käufer ist verpflichtet, seiner Untersuchungspflicht nach § 377 HGB auch bei Weiterveräußerung der Ware nachzukommen.

**11.7** Das Rückgriffsrecht des Käufers gegen den Verkäufer wegen solcher Ansprüche aus Sachmängelhaftung, die dem Käufer von dessen Abnehmern entgegengesetzt werden, ist ausgeschlossen, wenn der Käufer seiner Untersuchungs- und Rügepflicht nicht nachgekommen ist oder die Ware durch Verarbeitung abgeändert wurde.

**11.8** Die Haftung des Verkäufers nach den gesetzlichen Bestimmungen auf Schadensersatz ist uneingeschränkt gegeben, wenn eine dem Verkäufer zurechenbare Pflichtverletzung auf Vorsatz oder grober Fahrlässigkeit beruht. Soweit die dem Verkäufer zurechenbare Pflichtverletzung auf einfacher Fahrlässigkeit beruht und eine wesentliche Vertragspflicht schuldhaft verletzt ist, ist die Schadensersatzhaftung auf den vorhersehbaren Schaden beschränkt, der typischerweise in vergleichbaren Fällen eintritt. Im Übrigen ist die Haftung ausgeschlossen.

**11.9** Der Ersatz von entgangenem Gewinn und Schäden aus Betriebsunterbrechung ist auf Vorsatz und grobe Fahrlässigkeit beschränkt.

**11.10** Die Haftung nach den Bestimmungen des Produkthaftungsgesetzes oder vergleichbarer, unabdingbarer Rechte auch ausländischer Rechtsordnungen bleibt unberührt. Unberührt bleibt auch die Haftung wegen Verletzung von Leben, Körper und Gesundheit.

**11.11** Soweit eine Haftung nach Tatbeständen der Ziffer 11.9 begründet wird, ist die Haftung des Verkäufers bei ausländischen Rechtsordnungen im Verhältnis zum Käufer insoweit beschränkt, als es nach dem jeweiligen ausländischen Recht zulässig wäre.

**11.12** Soweit die Schadensersatzhaftung des Verkäufers ausgeschlossen oder eingeschränkt ist, gilt dies auch im Hinblick auf die persönliche Schadensersatzhaftung der Mitarbeiter, Vertreter und Erfüllungsgehilfen des Verkäufers.

### 12. Abtretungsverbot

**12.1** Sämtliche Ansprüche des Käufers gegen den Verkäufer sind nicht abtretbar.

**12.2** Der Verkäufer ist jederzeit auch ohne Zustimmung des Käufers dazu berechtigt, insbesondere mit ihm verbundene Unternehmen (im Sinne von § 15 AktG) als Erfüllungsgehilfen bei der Angebotserstellung und Vertragsabwicklung einzubinden.

### 13. Produkthaftung / Hinweispflichten

**13.1** Der Käufer darf die Ware nur bestimmungsgemäß verwenden und muss dafür sorgen, dass diese Ware nur an mit den Produktgefahren und -risiken vertraute Personen weiterveräußert wird.

**13.2** Der Käufer ist verpflichtet, bei Verwendung der Ware als Grundstoff und Teilprodukt von eigenen Produkten beim Inverkehrbringen des Endprodukts seiner Verpflichtung auch im Hinblick auf die von dem Verkäufer gelieferte Ware nachzukommen. Im Innenverhältnis stellt der Käufer den Verkäufer von der Geltendmachung von Ansprüchen bei Verletzung dieser Obliegenheit auf erstes Anfordern frei.

### 14. Geheimhaltung

Der Käufer muss alle geschäftlichen und technischen Informationen, die er vom Verkäufer erhalten hat, Dritten gegenüber wie Geschäfts- und Betriebsgeheimnisse behandeln, soweit diese nicht allgemein bekannt sind. Derartige Informationen dürfen ausschließlich zum vertragsgemäßen Zweck an Dritte, die über eine entsprechende Geheimhaltungsvereinbarung eingebunden sind, weitergegeben werden.

### 15. Datenschutz

Der Verkäufer erhebt, verarbeitet und nutzt personenbezogene Daten des Käufers nur unter Einhaltung der einschlägigen Datenschutzbestimmungen. Dementsprechend werden personenbezogene Daten des Käufers nur bei Vorliegen einer gesetzlichen Erlaubnis oder Vorliegen einer Einwilligung verwendet.

### 16. Sonstiges

**16.1** Erfüllungsort ist der Ort des jeweiligen Verkäuferwerkes.

**16.2** Gerichtsstand für sämtliche Streitigkeiten aus dem Vertrag ist Heilbronn. Der Verkäufer ist jedoch berechtigt, den Käufer auch an dessen allgemeinen Gerichtsstand zu verklagen.

**16.3** Für die Abwicklung von Verträgen auf Grundlage dieser Verkaufs- und Lieferbedingungen gilt ausschließlich deutsches Recht unter Ausschluss des Kollisionsrechts und des UN-Kaufrechts (CISG).

**16.4** Die Parteien sind verpflichtet, im Rahmen der Durchführung der Vertragsbeziehung sämtliche geltenden gesetzlichen Bestimmungen einzuhalten.

**16.5** Soweit eine oder mehrere der vorstehenden Bestimmungen ganz oder teilweise unwirksam sein sollte, so bleibt die Gültigkeit der übrigen Bestimmungen hiervon unberührt. Die ungültige Bestimmung ist dann durch eine gesetzlich zulässige Bestimmung zu ersetzen, mit der Sinn und Zweck dieser Verkaufs- und Lieferbedingungen in möglichst gleicher Weise erreicht werden.

## 1. Scope of Application

- 1.1** The Terms and Conditions of Sale and Delivery of MS Motorservice International GmbH (hereinafter referred to as the "Seller") shall apply exclusively. Opposing terms of the Buyer or terms that deviate from these Terms and Conditions of Sale and Delivery shall not apply unless the Seller has expressly agreed to the validity of deviating terms in writing. These Terms and Conditions of Sale and Delivery shall also apply if the Seller effects delivery to the Buyer without reservation in full knowledge of opposing terms of the Buyer or terms that deviate from its own Terms and Conditions of Sale and Delivery.
- 1.2** Separate agreements between the parties deviating from or supplementing these Terms and Conditions of Sale and Delivery shall take precedence. They shall be supplemented by these Terms and Conditions of Sale and Delivery unless special provisions have been agreed. The content of such agreements is contingent on a written contract or the written confirmation of the Seller.
- 1.3** The Terms and Conditions of Sale and Delivery shall also apply to future business transactions with the Buyer. By placing a purchase order and at the latest upon acceptance of the goods, the Buyer accepts these Terms and Conditions of Sale and Delivery.
- 1.4** These Terms and Conditions of Sale and Delivery shall only apply in B2B relationships.

## 2. Offer and Order Confirmation

- 2.1** Offers by the Seller shall in all cases be non-binding. If a purchase order from the Buyer legally qualifies as an offer, it shall only be accepted once it has been confirmed in writing by the Seller within four weeks. The contract shall come into effect at the latest once the ordered goods have been dispatched or their delivery time has been communicated, and in case of partial delivery, once the first delivery has been dispatched.
- 2.2** Modifications and other agreements shall only be binding once they have been confirmed by the Seller in writing.
- 2.3** The documents, drawings, details relating to weight and dimensions, samples etc. contained in the offers are only approximate specifications and shall not constitute guaranteed qualities. The Seller shall be entitled to deviate from the descriptions in the offer to the extent that these deviations are not of a fundamental or significant nature and the purpose according to the contract is not substantially restricted.
- 2.4** Insofar as goods are manufactured according to Buyer's drawings, the drawings created by the Buyer and approved by the Seller shall be decisive. Deviations from approved drawings must be separately agreed and any additional costs in this regard shall be reimbursed to the Seller.

## 3. Industrial Property Rights

- 3.1** The Seller shall reserve industrial property rights and copyright to all illustrations, drawings, calculations, and other documents; these items may neither be used for purposes other than those stipulated by the Seller, nor made accessible to third parties without the prior written consent of the Seller. This shall apply in particular to written documents that are designated as "confidential", "secret" or similar.
- 3.2** The Seller shall only be liable for claims relating to violations of industrial property rights and applications for industrial property rights resulting from contractual use of the goods, if at least one property right from the family of industrial property rights has been published by the European Patents Office or in one of the following states: Federal Republic of Germany, France, United Kingdom, Austria, China, Japan or the USA.
- 3.3** Where deliveries are effected according to drawings or other specifications from the Buyer and where third-party property rights are breached as a result of this, the Buyer shall indemnify the Seller against any claims internally.

## 4. Recommendations and Information

Recommendations and information shall be non-binding insofar as they do not refer to the goods themselves.

## 5. Prices

- 5.1** All prices are net prices and shall be quoted ex works (Incoterms® 2020, "EXW") excluding packaging, freight, postage and insurance. Statutory VAT shall be added at the current applicable rate.
- 5.2** Any additional costs incurred as a result of modification requests may be charged to the Buyer by the Seller.
- 5.3** Where events occur after conclusion of the contract that result in increased costs for the Seller in terms of primary purchasing costs, manufacture and/or shipment of the goods, the Seller shall be entitled to increase its prices accordingly.

## 6. Conditions of Payment

- 6.1** Invoices shall be due for payment within 14 days of the invoice date without any deductions. Even as part of an active business relationship, the Seller is entitled, at any time, to only carry out a delivery, either fully or in part, in exchange for payment in advance. Discounts shall only apply where expressly agreed in writing.
- 6.2** The Seller shall be entitled to offset a payment against the oldest, not specifically titled debt, even where the Buyer has earmarked the payment for a different purpose. Where costs or interest have already been incurred, the Seller shall be entitled to offset payments, in the first instance, against the costs, then against the interest, and finally against the principal debt.
- 6.3** The Buyer shall only have the right to offset insofar as its counterclaims are legally binding, are uncontested or have been acknowledged in writing by the Seller. The right of retention on the part of the Buyer shall be limited to claims arising from the contractual relationship.
- 6.4** The Seller is entitled to charge default interest at the applicable statutory default interest rate. The right to prove a higher default damage shall be expressly reserved.

## 7. Delivery / Delivery Time / Delay

- 7.1** Delivery periods and delivery dates shall only be deemed to have been agreed with binding effect where these are expressly confirmed in writing by the Seller. The Seller shall not be bound to the delivery date or delivery period where the Buyer does not meet its obligations in due time (to make anticipated payments, to provide required documents, to supply materials for manufacture etc.). The plea for non-fulfilment of the contract shall remain reserved.
- 7.2** Delivery periods begin at the earliest on the day of written conclusion of the contract and once all technical issues have been clarified.
- 7.3** In the event of change requests from the Buyer, the Seller shall be exempt from compliance with any agreed delivery date or delivery period. In such cases, the parties shall agree a new delivery date or a new delivery period.
- 7.4** Unless otherwise agreed, the delivery date or delivery period shall be deemed to have been adhered to when the Seller has made the goods available at the location agreed.
- 7.5** The Buyer may not assert claims due to delivery delays that do not result from intent or gross negligence on the part of the Seller. In particular, including with regard to other disruptions, this shall apply to delivery delays caused by force majeure, labour disputes, unrest, epidemics and/or pandemics, cyber-attacks, official measures, failure to deliver by suppliers and any other unforeseeable, unavoidable and serious events. In such cases, the agreed delivery date or delivery period shall be extended according to the duration of the delivery impediment. The Seller shall notify the Buyer of this and, where possible, specify a new expected delivery date. Compensation for loss of profit and stop of production shall be limited to intent.
- 7.6** Where the Buyer delays acceptance or violates any other obligation to cooperate, the Seller shall be entitled to demand compensation for damage suffered in this respect, including any additional costs. Furthermore, the Seller shall have the right to set an appropriate acceptance period for the Buyer and to withdraw from the contract where this period has expired to no avail, and to demand compensation for damage instead of the performance.
- 7.7** Partial deliveries shall be permitted to a reasonable extent. In this regard, claims made by the Buyer due to partial delivery or delayed delivery of the remaining goods shall be excluded.

## 8. Retention of Title

- 8.1** The Seller shall reserve title of all goods delivered until all payments pertaining to the supplier relationship, including any dues as shall arise in the future, have been effected in full. In the event of conduct contrary to contract, in particular as regards payment default, the Seller shall be entitled to claim back the goods.
- 8.2** The Buyer shall be obliged to handle the delivered goods with care and to insure them at their purchase price against any kind of loss at its own expense during the period of retention of title. The Seller shall remain entitled to insure the goods itself at the expense of the Buyer.
- 8.3** In case of pledge or other third-party intervention, the Buyer shall immediately notify the Seller in writing so that the latter can initiate a third-party action or other legal remedies. Where the third party fails to reimburse the legal and extrajudicial costs arising from this, the Buyer shall be liable for such costs.
- 8.4** The Buyer shall be entitled to sell on the goods in the ordinary course of business; it hereby, however, assigns to the Seller all receivables arising from the resale to its customers or third parties to the value of the final invoice amount (including statutory VAT) of the receivables, irrespective of whether the goods were sold without or following further processing. The Buyer shall remain entitled to collect these receivables even after delivery. The Buyer's right to collect the receivables itself shall remain unaffected by this.

**8.5** Where the goods delivered are inseparably mixed or combined with other items not belonging to the Seller, the Seller shall acquire joint ownership of the new or combined product in proportion to the value of the goods delivered (final invoice amount, including statutory VAT) in relation to the value of the other items at the time of combination or mixing. The Buyer shall safeguard the resulting sole ownership or joint ownership on behalf of the Seller.

**8.6** Where the value of the securities granted exceeds the claims of the Seller by more than a total of 20%, the Seller shall be obliged to release the excess securities upon request of the Buyer, at the Seller's option.

**8.7** If and to the extent that an agreement on the retention of title is not permitted under the relevant legal system, the Buyer shall provide the Seller with alternative appropriate securities on taking advantage of credit on goods.

## 9. Shipment, Transfer of Risk

- 9.1** Shipment shall be carried out at the risk of the Buyer. The risk shall transfer to the Buyer when the goods are dispatched at the very latest, even if the Seller has other services to perform.
- 9.2** Where shipment is delayed due to circumstances beyond the Seller's control, the risk shall pass to the Buyer from the day of notification of readiness for shipment. Upon written request of the Buyer and at the Buyer's expense, the Seller shall insure the shipment against breakage, damage in transit, as well as fire and water damage.
- 9.3** In accordance with the Packaging Act (Verpackungsgesetz), transport packaging and any other packaging shall not be taken back, with the exception of pallets. The Buyer shall be obliged to dispose of the packaging at its own expense.

## 10 Manufacturing Equipment

- 10.1** Insofar as the Buyer provides manufacturing equipment (e.g. tools, templates) to the Seller, these shall be sent to the Seller at no charge. The Seller can only be held liable for their loss, deterioration or incomplete return, including damage resulting from this, in cases of gross negligence or intent. This shall not apply in cases of legally mandatory liability.
- 10.2** Where manufacturing equipment is produced or procured by the Seller at the Buyer's request, the Seller shall invoice the Buyer for the costs for such equipment separately. The manufacturing equipment shall remain the property of the Seller. The Seller shall not be obliged to hand over said equipment to the Buyer. The above shall also apply in respect of follow-on tools. The following provision in Item 10.3 shall remain unaffected by this.
- 10.3** In the event of amortization of costs for the manufacturing equipment in excess of the part cost, the Buyer shall assume the costs not covered in case of non-amortization of a tool, including the costs for other type-specific equipment. Costs for models shall in all cases be for the account of the Buyer.
- 10.4** Drawings and documents provided to the Buyer by the Seller, as well as recommendations by the Seller in respect of design and production of the goods, may not be forwarded to third parties and can be claimed back by the Seller at any time.

## 11. Liability for Defects / Liability

- 11.1** The Seller shall not be liable for any damage caused by non-compliance with operating, maintenance and fitting instructions, inappropriate or improper use, faulty or negligent handling, natural wear and tear, incorrect storage or modification of the goods by the Buyer or third parties. Installation of the goods by the Buyer or a third party may only be carried out by trained and qualified personnel.
- 11.2** The Seller shall have the right to decide whether to remedy a defect or provide new goods. At the request of the Seller, the Buyer must hand the goods in question over to the Seller for examination. If the Seller incurs costs as a result of an unjustified request by the Buyer for the rectification of a defect (especially examination and transport costs), the Seller can demand compensation for these costs.
- 11.3** Expenses required for purposes of cure shall not be borne by the Seller in the event of increased expenses as a result of subsequent relocation of the goods to a location other than that of the original place of delivery.
- 11.4** If the Seller is sued by the Buyer by way of recourse after the Buyer itself has been sued by its customer due to defects, § 445a BGB (Bürgerliches Gesetzbuch - German Civil Code) shall apply to the enforcement of rights.
- 11.5** Claims based on liability for defects shall expire one year after handover of the goods unless the warranty claims are based on grossly negligent or wilful breach of obligation on the part of the Seller or one of its vicarious agents or on injury to life, limb, or health. Warranty claims for defects brought against the Seller by the Buyer by way of recourse in accordance with § 445a BGB are subject, without restriction, to the limitation period set out in § 445b BGB.
- 11.6** The Buyer shall also undertake to fulfil its obligation of examination pursuant to § 377 HGB (Handelsgesetzbuch - German Commercial Code) in the case of resale of the goods.
- 11.7** The Buyer's right of recourse against the Seller as a result of such claims based on liability for material defects made against the Buyer by its customers shall be excluded if the same has not fulfilled its obligation of examination and notification or if the goods have been modified by means of processing.
- 11.8** The Seller's liability for compensation according to statutory provisions shall apply without limitation if the same is responsible for breach of obligation based on intent or gross negligence. Insofar as a breach of obligation based on ordinary negligence is attributable to the Seller and an essential contractual obligation has been culpably violated, compensation for damages shall be limited to the amount of foreseeable damage that typically occurs in comparable cases. In all other cases, liability shall be excluded.
- 11.9** Compensation for loss of profit and damage resulting from business interruptions shall be limited to intent and gross negligence.
- 11.10** Liability according to the provisions of the Product Liability Law or similar, non-derogable rights of foreign jurisdiction shall remain unaffected. Liability resulting from injury to life, limb, and health shall also remain unaffected.
- 11.11** Insofar as liability arises according to the facts in Item 11.9, the liability of the Seller in case of foreign jurisdiction shall be limited in relation to the Buyer to the extent permissible according to the relevant foreign law.
- 11.12** Where the Seller's liability for compensation is excluded or limited, this shall also apply with regard to personal liability for compensation on the part of the Seller's employees, representatives, or vicarious agents.

## 12. Non-assignment Clause

- 12.1** All claims by the Buyer against the Seller shall be non-assignable.
- 12.2** The Seller is entitled at all times, even without the consent of the Buyer, to involve affiliated companies (in the sense of § 15 AktG (Aktengesetz - German Stock Corporation Act)) in particular in the generation of quotations and execution of contracts as vicarious agents.

## 13. Product Liability / Notification Obligation

- 13.1** The Buyer shall only use the goods according to their purpose and shall ensure that these goods are only resold to persons familiar with the hazards and risks associated with the goods.
- 13.2** The Buyer shall also undertake to fulfil its obligation to issue warnings in respect to the goods delivered by the Seller where the former uses these goods as base material or components for its own products when placing the final product on the market. The Buyer shall indemnify the Seller internally against assertion of claims arising from breach of this obligation upon first request.

## 14. Confidentiality

The Buyer shall treat as trade and company secret all business and technical information received from the Seller to the extent that this information is not public knowledge. Information of this nature may only be forwarded for the purposes of the contract to third parties who are bound by an appropriate non-disclosure agreement.

## 15. Data Protection

The Seller shall only collect, process and use personal data concerning the Buyer in accordance with the relevant data protection regulations. Consequently, personal data concerning the Buyer shall only be used on the basis of a legal ground or consent.

## 16. Other

- 16.1** The place of performance shall be the location of the relevant plant of the Seller.
- 16.2** The place of jurisdiction for all disputes arising from the contract shall be Heilbronn. The Seller shall, however, be entitled to file suit against the Buyer at its general place of jurisdiction as well.
- 16.3** Contracts based on these Terms and Conditions of Sale and Delivery shall be solely subject to German law excluding its conflict-of-laws provisions and the UN Convention on Contracts for the International Sale of Goods (CISG).
- 16.4** The parties shall be obliged to comply with all statutory provisions within the framework of the contractual relationship.
- 16.5** Should one or several of the above provisions be ineffective in whole or in part, the validity of the remaining provisions shall remain unaffected by this. The invalid provision shall in that case be replaced by a legally valid provision that most closely approximates the meaning and purpose of these Terms and Conditions of Sale and Delivery.



**1. Domaine de validité**

**1.1** Les conditions générales de vente et de livraison de la société MS Motorservice International GmbH (ci-après dénommée le « Vendeur ») s'appliquent à l'exclusion de toutes autres. Aucune condition de l'Acheteur, contraire aux présentes conditions de vente et de livraison ou différentes, n'est admise, excepté si le Vendeur a donné son accord exprès et écrit à l'application de conditions différentes. Les présentes conditions de vente et de livraison s'appliquent également si le Vendeur, en connaissance de conditions de l'Acheteur contrares ou différentes des siennes propres, effectue sans réserve la livraison à l'Acheteur.

**1.2** Toute convention distincte passée entre les parties et différente des présentes conditions de vente et de livraison ou les complétant, s'applique en priorité. Sauf réglementation spécifique applicable, les présentes conditions de vente et de livraison complètent lesdites conventions. Le contenu de ces dernières est déterminé par un contrat écrit ou une attestation écrite du Vendeur.

**1.3** Les présentes conditions de vente et de livraison sont de même applicables à toutes les opérations commerciales futures avec l'Acheteur. L'Acheteur accepte ces conditions de vente et de livraison en passant commande, et au plus tard en réceptionnant la marchandise.

**1.4** Les présentes conditions de vente et de livraison ne s'appliquent qu'aux entreprises.

**2. Offre et confirmation de commande**

**2.1** Les offres du Vendeur s'entendent toujours sans engagement. Une commande de l'Acheteur qui pourra être juridiquement qualifiée d'offre, n'est réputée acceptée que dès lors que le Vendeur l'a confirmée par écrit dans un délai de quatre semaines. Le contrat est conclu au plus tard lors de l'expédition ou de la communication de la date de mise à disposition de la marchandise commandée, et pour les livraisons partielles, lors de l'envoi de la première livraison.

**2.2** Les modifications et autres conventions ne présentent un caractère contraignant qu'une fois confirmées par écrit par le Vendeur.

**2.3** Les documents, dessins, indications de poids et de mesure, modèles, etc. figurant dans les offres ne sont que des indications approximatives ne constituant pas des caractéristiques. Le Vendeur est autorisé à apporter des variantes aux descriptifs figurant dans l'offre pourvu que celles-ci ne soient pas de nature fondamentale ou essentielle et qu'elles ne constituent pas un obstacle substantiel à l'objet du contrat.

**2.4** Si les marchandises sont fabriquées d'après des dessins de l'Acheteur, les dessins faits par celui-ci et approuvés par le Vendeur font foi. Les différences apportées aux dessins approuvés doivent être convenues séparément et les coûts supplémentaires éventuels en découlant donnent lieu à une rémunération du Vendeur.

**3. Droits de protection**

**3.1** Le Vendeur demeure titulaire des droits d'auteur et de propriété intellectuelle sur l'ensemble des illustrations, dessins, calculs et autres documents ; cette documentation ne peut être utilisée, sans autorisation préalable du Vendeur, à d'autres fins que celles spécifiées par le Vendeur, ni être communiquée à des tiers. La présente clause s'applique notamment aux documents écrits portant la mention « confidentiel » ou « secret » ou une mention similaire.

**3.2** La responsabilité du Vendeur est uniquement engagée en cas de recours exercé dans le cadre de l'utilisation contractuelle des marchandises suite à une violation de droits de protection et de demandes de droits de protection (droits de protection) dont un au moins appartenant à la famille des droits de protection est publié soit par l'Office européen des brevets soit dans l'un des États suivants : Allemagne, France, Grande-Bretagne, Chine, Japon ou USA.

**3.3** Dans le cas où des livraisons effectuées sur la base de dessins ou autres indications de l'Acheteur violeraient les droits de protection de tiers, l'Acheteur dégage le Vendeur de tout recours dans le cadre de leurs relations internes.

**4. Recommandations, informations et renseignements**

Les recommandations, informations et renseignements sont sans engagement pour autant qu'ils ne se rapportent pas à la marchandise elle-même.

**5. Prix**

**5.1** Tous nos prix sont nets et s'entendent « départ usine » (Incoterms® 2020, « EXW »), à l'exclusion de l'emballage, des frais, du port et de la garantie de valeur. La TVA est facturée en sus au taux légal en vigueur.

**5.2** Le Vendeur peut facturer à l'Acheteur les éventuels coûts supplémentaires découlant de demandes de modifications.

**5.3** En cas d'événements intervenant après la conclusion du contrat qui enchérirait le prix de revient du Vendeur pour ce qui est de l'achat, la production et/ou l'expédition de la marchandise, le Vendeur se réserve le droit d'appliquer une augmentation de prix correspondante.

**6. Modalités de paiement**

**6.1** Les factures sont payables sans déduction aucune dans les 14 jours suivant la date de facture. Le Vendeur se réserve à tout moment le droit d'exiger un paiement anticipé avant tout ou partie d'une livraison, et ce même dans le cadre d'une relation commerciale établie. Aucune remise n'est consentie en l'absence d'accord exprès par écrit.

**6.2** Le Vendeur se réserve le droit, même en cas d'affectation différente de la part de l'Acheteur, d'imputer un paiement en premier lieu sur la dette en souffrance la plus ancienne. En cas de frais ou d'intérêts déjà constatés, le Vendeur pourra imputer les paiements d'abord sur les frais, puis sur les intérêts et, en dernier lieu, sur la prestation principale.

**6.3** L'Acheteur ne pourra prétendre à un règlement par compensation que si et pour autant que son contre-prétentions ont un caractère exécutoire, qu'elles n'ont pas été contestées ou que le Vendeur les a reconnues par écrit. Le droit de rétention de l'Acheteur est limité aux créances découlant de la relation contractuelle.

**6.4** Le Vendeur pourra exiger des intérêts de retard d'un montant correspondant au taux d'intérêt légal respectivement en vigueur. Il se réserve expressément le droit d'apporter la preuve d'un préjudice plus élevé résultant du retard.

**7. Livraison / délai de livraison / retard**

**7.1** Les délais et dates de livraison ne sont réputés fermes que pour autant qu'ils ont été approuvés expressément par écrit par le Vendeur. Le Vendeur n'est pas tenu de respecter la date et le délai de livraison si l'Acheteur ne remplit pas ses obligations (paiement d'acomptes, fourniture de documents nécessaires, fournitures requises pour la fabrication, etc.) dans les délais impartis. Le Vendeur se réserve le droit de faire valoir l'exception d'inexécution du contrat.

**7.2** Les délais de livraison courent au plus tôt à compter de la date à laquelle le contrat est conclu par écrit et à laquelle l'ensemble des questions techniques est réglé.

**7.3** Dans l'hypothèse où l'Acheteur demanderait des modifications, le Vendeur n'est plus tenu de respecter la date ou le délai de livraison éventuellement convenus. Dans ce cas, les parties conviendront d'une nouvelle date ou d'un nouveau délai de livraison.

**7.4** Sauf convention contraire, la date ou le délai de livraison est réputé respecté dès lors que le Vendeur met la marchandise à disposition au lieu convenu.

**7.5** L'Acheteur ne peut faire valoir aucun droit en cas de retard de livraison qui ne serait causé ni intentionnellement ni du fait d'une négligence grave du Vendeur. Ceci s'applique également en cas de perturbations de toute nature, notamment lorsque les retards de livraison résultent d'un cas de force majeure, de mouvements sociaux, d'épidémies et/ou de pandémies, de cyberattaques, de mesures administratives, d'un défaut de livraison par des fournisseurs ainsi que de tout événement grave, imprévisible et inéluctable. Dans ces cas, la date ou le délai de livraison convenu est reporté d'une durée égale à celle des circonstances faisant obstacle à la livraison. Le Vendeur en informe l'Acheteur et communiquera, dans la mesure du possible, une nouvelle date de livraison prévue. Il ne pourra être fait droit à une demande d'indemnisation pour manque à gagner et préjudices découlant d'une interruption d'exploitation qu'en cas de faute intentionnelle.

**7.6** En cas de retard de l'Acheteur pour la réception ou de manquement de sa part à toute autre obligation de coopération, le Vendeur pourra exiger l'indemnisation du préjudice, y compris des coûts supplémentaires qui en résulteraient. Le Vendeur a en outre le droit de fixer à l'Acheteur un délai de réception raisonnable et, après expiration infructueuse de ce délai, de résilier le contrat et d'exiger une indemnisation en lieu et place de la prestation.

**7.7** Les livraisons partielles sont autorisées dans une mesure raisonnable. Il s'ensuit que tout recours de la part l'Acheteur en cas de livraison partielle ou de retard de livraison des quantités restantes est exclu.

**8. Réserve de propriété**

**8.1** Le Vendeur conserve la propriété de l'ensemble des marchandises livrées jusqu'à réception de l'ensemble des paiements, y compris les engagements à venir, résultant de la relation de fourniture. En cas de faute contractuelle, notamment de retard de paiement, le Vendeur se réserve le droit de réclamer la marchandise.

**8.2** L'Acheteur est tenu de prendre soin de la marchandise livrée et de l'assurer à ses frais, pour son prix d'achat, contre toute forme de disparition pendant la durée de la réserve de propriété. Le Vendeur conserve le droit d'assurer lui-même la marchandise aux frais de l'Acheteur.

**8.3** En cas de saisie ou autres interventions de tiers, l'Acheteur est tenu d'informer le Vendeur sans délai et par écrit, afin que ce dernier puisse faire valoir sa tierce opposition ou user d'autres voies de droit. Si le tiers ne rembourse pas les coûts judiciaires et extra judiciaires qui en résultent, la responsabilité de l'Acheteur est alors engagée.

**8.4** L'Acheteur est autorisé à revendre la marchandise dans le cadre d'opérations commerciales régulières ; il cède toutefois d'ores et déjà au Vendeur l'ensemble des créances, résultant de la revente de la marchandise en question à ses clients ou à des tiers à hauteur du montant final de la facture (y compris la TVA applicable), et ce indépendamment du fait que la marchandise ait été revendue sans ou après transformation. L'Acheteur est autorisé à recouvrer cette créance même après la livraison. La faculté du Vendeur de recouvrer lui-même ladite créance n'en est pas affectée.

**8.5** Si la marchandise livrée est mélangée ou alliée de manière indissociable à d'autres objets n'appartenant pas au Vendeur, ce dernier acquiert de ce fait une copropriété sur la chose nouvelle ou alliée au prorata de la valeur initiale de la marchandise livrée (montant final de la facture, TVA applicable comprise) par rapport à celle-ci ou aux autres éléments au moment du mélange ou de l'alliage. L'Acheteur sera le dépositaire pour le Vendeur de la propriété exclusive ou de la copropriété ainsi engendrée.

**8.6** Si la valeur des sûretés qu'il ont été consenties excède les créances du Vendeur de plus de vingt pour cent (20 %), celui-ci s'engage à libérer les sûretés excédentaires selon son choix, sur demande de l'Acheteur.

**8.7** Dans l'hypothèse où le système juridique en vigueur n'autoriserait pas de clause contractuelle de réserve de propriété, l'Acheteur faisant usage d'un crédit commercial s'engage à fournir au Vendeur d'autres garanties appropriées.

**9. Expédition, transfert de risque**

**9.1** L'expédition s'effectue au risque de l'Acheteur. Le risque est toujours transféré à l'Acheteur au plus tard lors de l'envoi de la marchandise, même lorsque d'autres prestations sont acceptées par le Vendeur.

**9.2** Si l'expédition subit un retard suite à des circonstances qui ne sont pas imputables au Vendeur, le risque est transféré à l'Acheteur à la date de l'avis d'expédition. Sur demande écrite de l'Acheteur, le Vendeur assurera l'envoi, aux frais de l'Acheteur, contre le bris, les dommages dus au transport, au feu et à l'eau.

**9.3** Les emballages de transport et autres ne sont pas repris conformément à la législation sur les emballages, à l'exception des palettes. L'Acheteur est tenu de procéder à ses propres frais à l'élimination des emballages.

**10 Moyens de fabrication**

**10.1** Dès lors que l'Acheteur met à la disposition du Vendeur des moyens de fabrication (p. ex. outillage/outils, moules), ces derniers doivent être envoyés gratuitement au Vendeur. La responsabilité du Vendeur ne pourra être engagée en ce qui concerne leur disparition, leur dégradation ou leur réexpédition incomplète et les dommages en résultant qu'en cas de négligence grave ou de faute intentionnelle. La présente clause ne s'applique pas si la responsabilité est obligatoire de par la loi.

**10.2** Si l'Acheteur charge le Vendeur de fabriquer ou d'acheter des moyens de fabrication, les coûts afférents sont facturés à l'Acheteur séparément. Les moyens de fabrication restent la propriété du Vendeur. Celui-ci n'est pas tenu de les restituer à l'Acheteur. Il en ira de même des outillages complémentaires. La règle suivante énoncée au paragraphe 10.3 n'en est pas affectée.

**10.3** En cas d'amortissement des coûts des moyens de fabrication supérieur au prix des pièces, l'Acheteur prendra à sa charge les coûts non couverts en cas de non amortissement d'un outil, y compris les coûts des divers équipements spécifiques. Les coûts des modèles sont toujours intégralement à la charge de l'Acheteur.

**10.4** La transmission à des tiers des dessins (schémas) et des documents remis à l'Acheteur par le Vendeur, ainsi que les propositions de ce dernier visant à la conception et à la production de la marchandise, n'est pas autorisée ; le Vendeur peut à tout moment en exiger la restitution.

**11. Responsabilité pour défaut de qualité / responsabilité**

**11.1** Le Vendeur décline toute responsabilité pour les dommages résultant d'un manquement aux consignes de manœuvre, de maintenance et de montage, de l'usage inapproprié ou non conforme ou incorrect de la marchandise, d'un traitement impropre ou négligent, de l'usure naturelle, d'un stockage inapproprié ou encore de modifications opérées sur la marchandise par l'Acheteur ou par des tiers. Le montage des marchandises par l'Acheteur ou par des tiers ne doit être effectué que par du personnel qualifié et compétent.

**11.2** Le Vendeur a le choix entre réparations et remplacement. Sur demande, l'Acheteur est tenu de remettre au Vendeur la marchandise faisant l'objet de la réclamation à des fins de vérification. Dans le cas où une demande d'élimination de défaut injustifiée émise par l'Acheteur engendre des coûts pour le Vendeur (en particulier des frais de contrôle et de transport), le Vendeur peut exiger le remboursement desdits coûts.

**11.3** Le Vendeur ne prend pas à sa charge les frais nécessaires à l'élimination du défaut s'ils sont augmentés du fait que la marchandise a été transportée ultérieurement à la livraison dans un autre endroit que le lieu initial de livraison.

**11.4** Si le recours de l'Acheteur prend la forme d'une demande de reprise auprès du Vendeur après que l'Acheteur a lui-même fait l'objet d'un recours pour défaut déposé par son client, l'article 445a du Code civil allemand (BGB) s'applique.

**11.5** Les droits issus de la responsabilité pour vice se prescrivent par 12 mois à compter de la remise de la marchandise, excepté si les droits de garantie en raison des défauts de la chose résultent d'un manquement intentionnel ou d'une négligence grave de la part du Vendeur ou de ses agents d'exécution ou d'une atteinte à la vie, à l'intégrité physique ou à la santé. Dans les cas où l'Acheteur fait valoir ses droits à la garantie des vices à l'encontre du Vendeur à des fins de reprise dans le cadre de l'article 445a du Code civil allemand (BGB), la réglementation sur la prescription de l'article 445b du Code civil allemand s'applique sans restriction aucune.

**11.6** L'Acheteur est tenu de respecter son obligation d'examen de la marchandise conformément à l'article 377 du Code civil allemand (HGB), même en cas de revente de celle-ci.

**11.7** En cas de réclamation pour défauts matériels déposée contre l'Acheteur par ses propres clients, tout droit de recours de l'Acheteur à l'encontre du Vendeur est exclu si l'Acheteur n'a pas respecté son obligation d'examiner les marchandises et d'aviser le Vendeur des défauts qu'il découvre ou si la marchandise a été soumise à un processus de modification.

**11.8** La responsabilité légale du Vendeur en matière d'indemnisation est limitée en cas de manquement intentionnel à ses obligations ou de négligence grave de sa part. Dans le cas où le Vendeur manquerait à ses obligations par négligence de conduite et où il serait porté atteinte de manière fautive à une obligation contractuelle majeure, le droit aux dommages et intérêts sera limité au dommage prévisible, intervenant de manière caractéristique dans des cas comparables. Toute responsabilité est exclue dans les autres cas.

**11.9** Il ne pourra être fait droit à une demande d'indemnisation pour manque à gagner et préjudices découlant d'une interruption d'exploitation qu'en cas de faute intentionnelle et de négligence grave.

**11.10** La responsabilité en vertu des dispositions de la loi sur la responsabilité du fait des produits ou de normes comparables et impératives de législations étrangères subsiste. Demeure également inchangée la responsabilité en cas d'atteinte à la vie, à l'intégrité du corps et à la santé.

**11.11** Dans le cas d'une responsabilité fondée, découlant de faits mentionnés au paragraphe 11.9, la responsabilité du Vendeur vis-à-vis de l'Acheteur, dans le cadre de législations étrangères, est limitée dans la même mesure qu'elle le serait par la législation étrangère en question.

**11.12** Toute exclusion ou limitation de la responsabilité du Vendeur en matière d'indemnisation s'applique également à la responsabilité personnelle des employés, représentants et agents d'exécution du Vendeur.

**12. Interdiction de cession**

**12.1** Tous les droits de l'Acheteur à l'encontre du Vendeur sont incessibles.

**12.2** Le Vendeur se réserve le droit, à tout moment et sans l'accord de l'Acheteur, d'engager des entreprises, notamment celles qui lui sont liées (au sens de l'article 15 de la loi allemande sur les sociétés anonymes « Aktiengesetz ») en qualité d'agents d'exécution aux fins de l'élaboration des offres et de l'exécution du contrat.

**13. Responsabilité du fait des produits défectueux / obligations d'information**

**13.1** L'Acheteur ne devra utiliser la marchandise que de manière conforme à sa destination et devra veiller à ce qu'elle ne soit revendue qu'à des personnes au fait des dangers et risques du produit.

**13.2** Si l'Acheteur utilise le produit comme matériau de base ou comme sous-produit de ses propres produits, il est tenu, lors de la mise en circulation du produit final, de respecter son obligation d'avertissement, relative également à la marchandise qui lui a été fournie par le Vendeur. Dans le cadre de leurs relations internes, l'Acheteur libérera le Vendeur, à sa première demande, de tout recours exercé contre ce dernier pour manquement à ces obligations.

**14. Confidentialité**

Vis-à-vis des tiers, l'Acheteur est tenu de garder le secret en matière commerciale et industrielle sur toutes les informations commerciales et techniques qu'il a reçues de la part du Vendeur, dans la mesure où elles ne sont pas généralement connues. Les informations de cette nature ne pourront être communiquées qu'à des fins exclusivement contractuelles à des tiers liés par un accord de confidentialité approprié.

**15. Protection des données**

Le Vendeur collecte, traite et exploite les données à caractère personnel de l'Acheteur dans le cadre exclusif de la réglementation applicable sur la protection des données. En conséquence, l'utilisation des données à caractère personnel de l'Acheteur est soumise à autorisation légale ou au consentement de l'Acheteur.

**16. Divers**

**16.1** Le lieu d'exécution est celui où se trouve l'usine du Vendeur concernée.

**16.2** Le tribunal compétent pour tout litige découlant du contrat est Heilbronn. Toutefois, le Vendeur est autorisé à assigner l'Acheteur également devant le tribunal de droit commun compétent pour sa domiciliation.

**16.3** L'exécution de contrats basée sur les présentes conditions de vente et de livraison est exclusivement régie par le droit allemand, à l'exclusion des règles de conflits de lois et de la Convention des Nations Unies sur les contrats de vente internationale de marchandises (CVIM).

**16.4** Les parties sont tenues, dans le cadre de l'exécution de la relation contractuelle, de respecter l'ensemble des dispositions légales en vigueur.

**16.5** En cas d'invalidité totale ou partielle d'une ou plusieurs clauses ci-dessus, la validité des autres clauses n'en sera pas affectée. La clause invalide devra être remplacée par une clause légale s'approchant au plus près du sens et de l'objectif des présentes conditions de vente et de livraison.

## 1.1. Ámbito de validez

- 1.1 Se aplicarán exclusivamente las condiciones de venta y entrega de MS Motorservice International GmbH (en adelante, «vendedor»). Las condiciones contrarias o que difieran de las presentes condiciones de venta y entrega del comprador se rechazarán, salvo que el vendedor haya aceptado expresamente por escrito la validez de las condiciones divergentes. Estas condiciones de venta y entrega también se aplicarán si el vendedor realiza la entrega al comprador sin reservas teniendo conocimiento de condiciones contrarias del comprador o que diverjan de las condiciones de venta y entrega propias.
- 1.2 Tienen prioridad los acuerdos separados entre las partes que se desvíen o complementen estos términos y condiciones de venta y entrega. Salvo que se hayan dictado disposiciones especiales, se completan con las presentes condiciones de venta y entrega. Para el contenido de semejantes acuerdos es decisivo un contrato escrito o una confirmación escrita del vendedor.
- 1.3 Las condiciones de venta y entrega también se aplicarán a todas las actividades futuras con el comprador. El comprador aceptará estas condiciones de venta y entrega con la realización del pedido, no obstante, a más tardar, al aceptar la mercancía.
- 1.4 Las presentes condiciones de venta y entrega solo aplican para empresas.

## 2. Oferta y confirmación del pedido

- 2.1 Las ofertas del vendedor no son obligatorias. Si un pedido efectuado por el comprador se considera legalmente una oferta, solo se considerará aceptado si el vendedor lo confirma por escrito en un plazo de cuatro semanas. A más tardar, el contrato se celebrará con el envío de la mercancía pedida o cuando se notifique que la mercancía solicitada está disponible; en caso de entregas parciales, cuando se envía la primera entrega.
- 2.2 Las modificaciones y otros acuerdos solo son vinculantes cuando el vendedor los confirme por escrito.
- 2.3 Los documentos, planos, pesos y dimensiones, muestras, etcétera, contenidos en las ofertas solo contienen datos aproximados y no constituyen características garantizadas. El vendedor tiene derecho a divergir de las descripciones de la oferta en tanto dichas divergencias no sean de carácter básico o fundamental, y no limiten en lo esencial la finalidad del contrato.
- 2.4 Cuando las mercancías se producen de acuerdo con los dibujos de los compradores, los planos elaborados por el comprador y aprobados por vendedor serán determinantes. Las divergencias de los planos autorizados deben acordarse por separado y cualquier coste añadido al respecto deberá remunerarse al vendedor.

## 3. Derechos protegidos

- 3.1 El vendedor se reserva los derechos de propiedad y de autor con respecto a todas las ilustraciones, planos, cálculos y demás documentos y no se podrán emplear para fines diferentes de los indicados por el vendedor ni relevarse a terceros, salvo que se disponga de una autorización previa por escrito del vendedor. Esto se aplica especialmente a la documentación escrita designada como «confidencial», «secreta» o de forma similar.
- 3.2 El vendedor solo es responsable de los daños ocasionados por el uso contractualmente correcto de las mercancías derivadas de la violación de los derechos protegidos y solicitudes de los derechos protegidos (derechos protegidos), de los cuales al menos uno de la familia de los derechos protegidos figurará en la lista de la Oficina Europea de Patentes o en uno de los estados de la República Federal de Alemania, Francia, Gran Bretaña, Austria, China, Japón o los EE. UU.
- 3.3 Si las entregas se realizan basándose en planos u otra información proporcionada por el comprador y con ello se violan los derechos de propiedad de terceros, el comprador deberá indemnizar internamente al vendedor por todas las reclamaciones.

## 4. Recomendaciones, información y declaraciones

Las recomendaciones, la información y las declaraciones no son vinculantes, siempre que no se refieran a la mercancía misma.

## 5. Precios

- 5.1 Todos los precios son precios netos y se entenderán «franco fábrica» («EXW» Incoterms®2020) sin el embalaje, transporte, franqueo y garantía de valor. Se agregará el impuesto legal sobre las ventas a la tasa aplicable.
- 5.2 El vendedor podrá facturarle al comprador cualquier gasto adicional resultante de solicitudes de modificación.
- 5.3 Si, tras celebrarse el contrato, se produjeran hechos que encarecieran los gastos directos del vendedor en la compra, la fabricación y/o el envío de la mercancía, el vendedor tendrá derecho a un incremento correspondiente del precio.

## 6. Condiciones de pago

- 6.1 Las facturas deberán abonarse sin descuento en un plazo de 14 días a partir de la fecha de la factura. El vendedor tiene derecho en cualquier momento, incluso durante una relación comercial en curso, a realizar una entrega total o parcial solo contra pago por adelantado. Los descuentos solo se aplicarán en caso de acuerdo expreso por escrito.
- 6.2 El vendedor tendrá derecho de facturar primero el pago de una deuda más antigua no titulada, incluso con la asignación obligatoria contraria del comprador. Si ya se han generado costes o intereses, el vendedor tendrá derecho a facturar primero el pago de los costes, a continuación, el de los intereses y, por último, el de la prestación principal.
- 6.3 El derecho a compensación corresponderá al comprador solo cuando sus contraprestaciones hayan adquirido firmeza legal, sean indiscutibles o hayan sido reconocidas por escrito por el vendedor. El derecho de retención del comprador estará limitado a los derechos de la relación contractual.
- 6.4 El vendedor tendrá derecho a exigir intereses de demora por el importe del tipo de interés de demora respectivo legalmente vigente. Queda reservado expresamente el derecho a acreditar mayores daños por demora.

## 7. Entrega/plazo de entrega/demora

- 7.1 Los plazos y fechas de entrega solo se aplicarán si el vendedor los acepta expresamente por escrito. El vendedor no estará obligado a cumplir con la fecha o plazo de entrega si el comprador incumple sus obligaciones (pago de los adelantos, aportación de los documentos necesarios, contribuciones a la producción, etcétera) en el tiempo previsto. Queda reservada la excepción por incumplimiento del contrato.
- 7.2 Los plazos de entrega comenzarán no antes del día en que se firme el contrato y todas las cuestiones técnicas hayan quedado resueltas.
- 7.3 Si el comprador solicita modificaciones, el vendedor quedará exento de cumplir con cualquier fecha o plazo de entrega acordado. En este caso, las partes acordarán una nueva fecha o un nuevo plazo de entrega.
- 7.4 Si no se acuerda nada distinto, la fecha o el plazo de entrega se cumplirá cuando el vendedor haya puesto a disposición la mercancía en el lugar acordado.
- 7.5 El cliente no podrá presentar ninguna reclamación debido a demoras en la entrega que no se deriven de una acción dolosa o negligencia grave del vendedor. Esto se aplica también para otros inconvenientes, especialmente, a las demoras en la entrega debidas a fuerza mayor, conflictos laborales, disturbios, epidemias y/o pandemias, ataques cibernéticos, medidas oficiales, carencia de suministros por parte de proveedores, así como a otros eventos imprevisibles, inevitables y de gravedad. En estos casos, la fecha o plazo de entrega acordado se aplazará en función de la duración del impedimento para la entrega, por lo que el vendedor informará al comprador y, si es posible, facilitará una nueva fecha prevista de entrega. La indemnización por pérdida de beneficios y daños resultante de la interrupción del servicio se limitará al dolo.
- 7.6 Si el comprador incurre en demora en la aceptación o infringe otros deberes de cooperación, el vendedor tendrá derecho a exigir una indemnización por los daños causados, que incluye los posibles gastos adicionales. Asimismo, el vendedor tendrá derecho a establecer un plazo de aceptación razonable para el comprador y, después de su vencimiento sin haber resultado, a rescindir el contrato y exigir una indemnización por daños en lugar de la prestación.
- 7.7 Se permitirán las entregas parciales de manera razonable. En este sentido, quedan excluidas las reclamaciones del comprador debido a la entrega parcial o una entrega con retraso de la cantidad restante.

## 8. Reserva de dominio

- 8.1 El vendedor conservará la propiedad de todas las mercancías entregadas hasta la recepción de todos los pagos correspondientes a la relación de suministro y futuras obligaciones correspondientes. En caso de incumplimiento del contrato, especialmente, en caso de demora del pago, el vendedor tendrá derecho a exigir la devolución de las mercancías.
- 8.2 El comprador estará obligado a tratar las mercancías entregadas con cuidado y a asegurarlas por cuenta propia contra cualquier forma de pérdida durante el período de reserva de dominio por el precio de compra. El vendedor seguirá teniendo derecho a asegurar el mismo la mercancía a cargo del comprador.
- 8.3 El comprador deberá comunicar sin dilación alguna y por escrito al vendedor cualquier caso de embargo o demás intervenciones de terceros, de modo que éste pueda ejercitar la reclamación por tercera u otros recursos. En tanto que la parte tercera no restituya los costes judiciales y extrajudiciales generados por ello, el comprador asumirá la responsabilidad al respecto.
- 8.4 El comprador tendrá derecho a revender la mercancía en el transcurso normal de su actividad comercial. No obstante, este cederá en ese momento al vendedor la totalidad de los cobros pendientes por el importe de la suma final de la factura (incluido el impuesto sobre el valor añadido) correspondiente al crédito que haya obtenido de la reventa frente a sus clientes o terceros, independientemente de si la mercancía fue vendida sin ser procesada o después de ello. El comprador conserva el derecho de cobrar esta deuda incluso después de la entrega. El derecho del vendedor a cobrar la deuda él mismo no será afectado.

- 8.5 Si las mercancías entregadas se mezclan o combinan inseparablemente con otras mercancías que no pertenecen al vendedor, el vendedor adquirirá la copropiedad del nuevo o combinado objeto en relación al valor de la mercancía entregada (importe de la suma final de la factura legal IVA incluido) para el otro u otros objetos en el momento de la mezcla o combinación. El comprador custodiará para el vendedor la propiedad o copropiedad así surgida.
- 8.6 En el caso de que el valor de las garantías entregadas exceda del valor de los créditos del vendedor en total en más de un 20 %, el vendedor tendrá la obligación de liberar, a elección del vendedor, el exceso de las garantías a solicitud del comprador.
- 8.7 Si y en tanto que el ordenamiento jurídico determinante no permita el acuerdo de una reserva de dominio, el comprador aportará otros avales razonables al vendedor si se utilizan créditos comerciales.

## 9. Envío, transmisión del riesgo

- 9.1 El envío se efectuará a riesgo del comprador. El riesgo se transmitirá al comprador, a más tardar, con el envío de la mercancía, también si el vendedor se hace cargo de otras prestaciones.
- 9.2 Si la entrega se retrasa debido a circunstancias de las que el vendedor no es responsable, el riesgo pasará al comprador en el momento en que se comunica al comprador que la mercancía está lista para el envío. Previa solicitud por escrito del comprador, el vendedor asegurará el envío contra daños por rotura, transporte, fuego y agua, y el comprador se hará cargo de los costes.
- 9.3 De conformidad con la ley de embalajes, no se aceptará la devolución de embalajes de transporte y demás embalajes; a excepción de las paletas. El comprador está obligado a eliminar el embalaje por cuenta propia.

## 10. Elementos de producción

- 10.1 En caso de que el comprador suministre elementos de producción (tales como herramientas y/o moldes), dichos elementos deberán enviarse sin coste alguno al vendedor. El vendedor asume la responsabilidad por su pérdida, deterioro o devolución incompleta y averías resultantes solo en casos de negligencia grave o dolo. Esto no se aplica si la responsabilidad es obligatoria por ley.
- 10.2 Si el vendedor fabrica o adquiere los elementos de producción en nombre del comprador, el vendedor facturará al comprador los costes por separado. El vendedor conservará la plena propiedad de los elementos de producción, sin que exista ninguna obligación de entregarlos al comprador. Lo anterior se aplica también a los útiles secuenciales. Esto no afecta a la regulación siguiente del apartado 10.3.
- 10.3 Si los costes de los elementos de producción se amortizan mediante el precio de las piezas, si una herramienta no se amortiza, el comprador asume los costes no cubiertos, incluidos los costes de otras instalaciones específicas del tipo. Los costes de los modelos siempre corren a cargo del comprador en su totalidad.
- 10.4 Los planos y la documentación entregados al comprador por el vendedor, así como las propuestas del vendedor para diseñar y fabricar la mercancía, no podrán entregarse a terceros y el vendedor podrá exigir su devolución en cualquier momento.

## 11. Responsabilidad por saneamiento de defectos/responsabilidad

- 11.1 El vendedor no asume responsabilidad por los daños causados por el incumplimiento de las instrucciones para el manejo, mantenimiento y montaje, la utilización inadecuada o indebida, el uso erróneo o negligente y el desgaste natural, el almacenamiento incorrecto o por las manipulaciones realizadas por el comprador o por terceros en la mercancía. El comprador o terceros solo podrán montar las mercancías empleando a personal especializado e instruido.
- 11.2 El vendedor tendrá derecho de elegir entre la reparación o sustitución del artículo defectuoso por uno nuevo. El comprador tiene que entregarle al vendedor la mercancía en cuestión a petición de éste para fines de inspección. Si el vendedor incurre en costes (en particular, costes de inspección y transporte) debido a la solicitud injustificada del comprador de rectificar un defecto, el vendedor puede exigir el reembolso de estos costes.
- 11.3 El vendedor no se hará cargo de los costes necesarios con fines de cumplimiento posterior si estos aumentan debido a que, tras la entrega, la mercancía hubiera sido llevada a otro lugar distinto al lugar de entrega original.
- 11.4 Si el comprador reclama al vendedor mediante recurso después de que el propio comprador haya sido demandado por su cliente por defectos, se aplicará el artículo 445a del Código Civil alemán (BGB, en sus siglas en alemán).
- 11.5 Las reclamaciones relacionadas con la responsabilidad por saneamiento de defectos caducarán después de un año desde la entrega de la mercancía, salvo que las reclamaciones de responsabilidad debida a defectos materiales se fundamenten en un incumplimiento doloso o gravemente negligente del contrato por parte del vendedor o sus auxiliares ejecutivos o en lo que concierne a daños personales que afecten a la integridad física y la salud. En caso de reclamaciones de garantía por defectos que el comprador oponga al vendedor mediante recurso de conformidad con el artículo 445a del Código Civil alemán (BGB, en sus siglas en alemán), se aplicará sin restricciones el plazo de prescripción del artículo 445b del Código Civil alemán (BGB).
- 11.6 El comprador estará obligado a cumplir con la obligación de realizar inspecciones de acuerdo con la legislación alemana, art. 377 del código de comercio alemán, incluso con la reventa de la mercancía.
- 11.7 El derecho de recurso del comprador contra el vendedor en cuanto a la responsabilidad por saneamiento de defectos, al que los clientes del comprador puedan oponerse, quedará excluido cuando el comprador no cumpla con la obligación de realizar pruebas y reclamaciones o cuando la mercancía haya sido sometida a una transformación.
- 11.8 La responsabilidad del vendedor en virtud de las disposiciones legales para la responsabilidad por daños y perjuicios se cumplirá íntegramente cuando un incumplimiento imputable de una obligación del vendedor se fundamenta en dolo o negligencia grave. En la medida en que el incumplimiento imputable de la obligación del vendedor se fundamenta en una negligencia simple y se viole una obligación esencial del contrato, la responsabilidad por daños y perjuicios se limitará al daño previsible que se produce normalmente en casos similares. Por lo demás, quedará excluida la responsabilidad.
- 11.9 La indemnización por pérdida de beneficios y daños resultante de la interrupción del servicio se limita al dolo y negligencia grave.
- 11.10 Esto no afectará a la responsabilidad según las disposiciones de la ley alemana de responsabilidad relativa a los productos defectuosos o también los derechos fundamentales comparables de otras legislaciones extranjeras. Tampoco se verá afectada la responsabilidad debida a lesiones a la vida, la integridad física y la salud.
- 11.11 Si se fundamenta una responsabilidad según los hechos del apartado 11.9, la responsabilidad del vendedor frente al comprador en el caso de ordenamientos jurídicos extranjeros se limitará en la medida en que estuviera permitido por la legislación extranjera correspondiente.
- 11.12 Siempre que la responsabilidad por daños y perjuicios del vendedor se excluya o esté limitada, esto también se aplicará respecto a la responsabilidad personal por daños y perjuicios de los empleados, representantes y auxiliares ejecutivos.

## 12. Prohibición de cesión

- 12.1 Todas las reclamaciones del comprador frente al vendedor no serán transferibles.
- 12.2 El vendedor tiene derecho en cualquier momento, incluso sin el consentimiento del comprador, a recurrir a empresas afiliadas a él (en el sentido del artículo 15 AktG (Ley de las sociedades anónimas alemanas)) como agentes auxiliares en la preparación de la oferta y la ejecución del contrato.

## 13. Responsabilidad relativa a los productos defectuosos/deber de advertencia

- 13.1 El comprador podrá utilizar la mercancía solo de la manera prevista y deberá asegurarse de que esta mercancía se revenda solo a las personas familiarizadas con los peligros y riesgos del producto.
- 13.2 Al usar los productos como producto primario y subproducto en propios productos, el comprador estará obligado a cumplir también con el deber de advertencia en cuanto a los productos entregados por el vendedor al comercializar el producto final. En las relaciones internas, el comprador renunciará a toda pretensión contra el vendedor en cuanto al incumplimiento de la presente obligación al primer requerimiento.

## 14. Obligación de confidencialidad

El comprador deberá tratar toda la información comercial y técnica que ha recibido del vendedor, en tanto esta no sea conocida con carácter general, como secreto comercial e industrial frente a terceros. Este tipo de información solo se podrá transmitir a terceras partes, que deberán comprometerse con el correspondiente acuerdo de confidencialidad, con fines contractuales.

## 15. Protección de datos

El vendedor recopila, procesa y utiliza los datos personales del comprador únicamente de conformidad con las normas de protección de datos pertinentes. En consecuencia, los datos personales del comprador solo se utilizarán si existe permiso o consentimiento legal.

## 16. Otros

- 16.1 El lugar de cumplimiento será el lugar en el que se encuentre la fábrica de venta correspondiente.
- 16.2 La jurisdicción para todos los litigios derivados del contrato será la de Heilbronn (Alemania). No obstante, el vendedor también tendrá derecho a demandar al comprador en su jurisdicción general.
- 16.3 Para la ejecución de los contratos sobre la base de las presentes condiciones de venta y entrega, se aplicará exclusivamente la ley alemana con exclusión del derecho de colisión y del derecho de adquisición de las Naciones Unidas (CISG).
- 16.4 En el contexto de la ejecución de la relación contractual, las partes están obligadas a cumplir todas las disposiciones legales aplicables.
- 16.5 Si una o varias de las disposiciones anteriores resultara total o parcialmente inválida, esto no afectará a la validez de las demás disposiciones. La disposición ineficaz deberá sustituirse por una disposición legal admisible con la que se obtengan el sentido y la finalidad de estas condiciones de venta y entrega en la medida de lo posible.



## 1. Сфера применения

**1.1** Условия продажи и поставки MS Motorservice International GmbH (далее – «продавец») имеют исключительное действие. Противоположные или отличающиеся от настоящих условий продажи и поставки условия покупателя не признаются, за исключением случаев, когда продавец однозначно письменно признал их действительность. Настоящие условия продажи и поставки действительны и в том случае, если продавец, зная противоположные или отличающиеся от собственных условий продажи и поставки условия покупателя, осуществляет поставку для покупателя без предварительных договоренностей.

**1.2** Отдельные соглашения между сторонами, отступающие от данных условий продажи и поставки, или дополняющие их, имеют преимущественное действие. В этой части, если не вычленили какие-либо специальные положения, эти соглашения дополняют настоящие условия продажи и поставки. Для вступления в силу содержания таких соглашений требуется письменный договор или письменное подтверждение продавца.

**1.3** Условия продажи и поставки распространяются и на все будущие сделки с покупателем. Условия продажи и поставки признаются покупателем при размещении заказа, самое позднее – при приеме товара.

**1.4** Настоящие условия продажи и поставки действуют только в отношении предпринимателей.

## 2. Предложение и подтверждение заказа

**2.1** Предложения продавца всегда являются свободными. Если заказ покупателя квалифицируется с правовой точки зрения как предложение, он считается принятым только при его письменном подтверждении продавцом в течение четырех недель. Договор вступает в силу не позднее чем с момента отправки заказанного товара или уведомления о времени его готовности к отгрузке, при частичной поставке – с момента отправки первой партии.

**2.2** Изменения и прочие соглашения являются обязательными только в случае их письменного подтверждения продавцом.

**2.3** Содержащиеся в предложениях документы, чертежи, данные о весе и размерах, образцы и т. д., являются лишь приблизительными данными, а не характеристиками качества. Продавец имеет право отклониться от описаний в предложениях, если такое отклонение не играет решающей или существенной роли, а цель договора при этом не будет существенно ограничена.

**2.4** Если товары изготавливаются по чертежам покупателя, определяющими являются составленные покупателем и одобренные продавцом чертежи. Отклонения от уже одобренных чертежей согласовываются отдельно, а любые дополнительные расходы должны быть возмещены продавцу.

## 3. Патенты

**3.1** Продавец сохраняет за собой право собственности и авторское право на все изображения, чертежи, расчеты и прочие документы; без предварительного письменного разрешения продавца они не могут быть использованы в целях, не указанных продавцом, либо переданы третьим лицам. В особенности это касается письменных документов с пометками «конфиденциально», «секретно» или подобными им.

**3.2** Продавец несет ответственность только за претензии, возникшие при использовании товара в соответствии с договором, в связи с несоблюдением патентов и заявок на выдачу патентов (охраняемых прав), по меньшей мере, одним из семейства патентов был опубликован либо Европейским патентным ведомством, либо в одной из следующих стран: Федеративная Республика Германия, Франция, Великобритания, Австрия, Китай, Япония или США.

**3.3** Если поставки осуществляются по чертежам или прочим данным покупателя, и при этом нарушаются патенты третьих лиц, покупатель, в рамках отношений партнеров по договору, снимает с продавца все претензии.

## 4. Рекомендации, информация и справки

Рекомендации, информация и справки являются необязательными, если они не относятся непосредственно к товару.

## 5. Цены

**5.1** Все цены нетто и действуют на условиях франко-завод (Incoterms®2020, «EXW»), за исключением упаковки, фрахта, почтового сбора и индекса. Законодательно установленный налог с оборота в соответствующем размере начисляется дополнительно.

**5.2** Возможные дополнительные затраты, возникшие в связи с пожеланиями покупателя по изменению, могут быть включены продавцом в счет покупателя.

**5.3** В случае, если после заключения договора возникнут события, повышающие себестоимость товара продавца при его закупке, производстве и/или отгрузке, продавец имеет право на соответствующее повышение цены.

## 6. Условия оплаты

**6.1** Счета подлежат полной оплате в течение 14 дней со дня выставления счета. Продавец вправе, в том числе в рамках текущих деловых отношений, в любое время осуществить поставку в полном объеме или частично только по предоплате. Скидки действуют только при наличии явного письменного соглашения.

**6.2** Продавец имеет право, даже при противоположной целевой привязке покупателя, начислить оплату сначала в счет старого, не документированного долга. В случае возникновения расходов и процентов продавец имеет право зачесть платежи сначала на оплату расходов, затем процентов, и в последнюю очередь – на оплату основного продукта или услуги.

**6.3** Право на взаимный зачет встречных требований покупатель имеет только в случае, если встречные требования определены имеющими законную силу, неоспоримы или письменно признаны продавцом. Право покупателя отказаться от выполнения своих обязательств по договору ограничено претензиями, возникающими из договорных отношений.

**6.4** Продавец имеет право требовать пени за просрочку исполнения обязательства в размере действующей предусмотренной законодательством процентной ставки за просрочку платежа. Сохраняется право обоснования более высокого ущерба от просрочки.

## 7. Поставка / срок поставки / задержка

**7.1** Договоренность о сроках и дате поставки считается обязательной только в случае, если она однозначно письменно одобрена продавцом. Продавец не обязан соблюдать дату и/или срок поставки, если покупатель не выполняет свои обязательства (выплата задатка, предоставление необходимых документов, размещение заказов на производство и т. д.) своевременно. Сохраняется право на возмещение стороны о неисполнении договора другой стороной.

**7.2** Срок поставки начинается не ранее дня письменного заключения договора и разъяснения всех технических вопросов.

**7.3** При наличии пожеланий покупателя по изменению, продавец освобождается от соблюдения любых согласованных даты и/или срока поставки. В данном случае стороны согласуют новую дату поставки или новые сроки поставки.

**7.4** При отсутствии иных договоренностей, дата поставки или срок поставки считаются соблюденными, если товар доставлен продавцом в согласованное место.

**7.5** Покупатель не имеет права предъявлять претензии по задержкам поставки, не вызванным умыслом или грубой халатностью продавца. В частности, в том числе при прочих нарушениях, это касается задержки поставки в связи с форс-мажорными обстоятельствами, заботками, беспорядками, эпидемиями и/или пандемиями, кибератаками, административными мерами, отсутствием поставок товаров субпоставщиками и прочими непредвиденными, неотвратимыми и существенными обстоятельствами. Согласованные сроки и даты поставки в этом случае продлеваются в соответствии с длительностью действия фактора задержки поставки. Продавец информирует об этом покупателя и, по возможности, сообщает новую предположительную дату поставки. Возмещаются только упущенная прибыль и ущерб в связи с простоем, которые вызваны умыселными действиями.

**7.6** В случае просрочки в получении поставленного товара покупателем или нарушения им прочих обязательств по содействию продавец имеет право требовать возмещения понесенного ущерба, включая возможные дополнительные расходы. Кроме того, продавец имеет право устанавливать приемлемый срок приема товара покупателем, а по истечении срока выйти из договора и потребовать возмещения ущерба в виде выполнения договорных обязательств.

**7.7** Частичные поставки допустимы в приемлемом объеме. В связи с этим претензии покупателя по частичной поставке или задержанной поставке остаточной партии исключаются.

## 8. Оговорка об условиях перехода права собственности на товар

**8.1** Продавец сохраняет право собственности на все поставленные товары до поступления всех платежей в рамках отношений, возникающих при осуществлении поставок, а также будущих обязательств. При действиях, противоречащих условиям договора, в частности, при задержке оплаты, продавец имеет право потребовать вернуть товар.

**8.2** Покупатель обязуется бережно обращаться с поставленными товарами, и в течение срока перехода права собственности на товар, за собственный счет застраховать его против любого вида уничтожения по купольной стоимости. За продавцом сохраняется право самостоятельно страховать товар за счет покупателя.

**8.3** При наличии ареста на имущество или прочих влечательств третьих лиц покупатель обязан незамедлительно письменно информировать продавца, чтобы он смог подать иск третьего лица о праве собственности на имущество или иную апелляцию. В случае, если третьи лица не возместят возникшие в связи с этим судебные и внесудебные расходы, ответственность за них несет покупатель.

**8.4** Покупатель имеет право продать товар в рамках нормального делового процесса, однако он уже сейчас уступает продавцу все требования в размере итоговой суммы по счету-фактуре (включая установленный законом налог с оборота), которые у него возникают при перепродаже по отношению к клиенту или третьему лицу, независимо от того, был ли товар перепродан без переработки или после нее. Покупатель имеет право на предъявление этого требования к оплате и после передачи товара. Это не отменяет право продавца на самостоятельное возмещение этого требования.

**8.5** При нераздельном смешении и соединении поставленного товара с предметами, не являющимися собственностью продавца, продавец приобретает право долевой собственности на новое или соединенное имущество в пропорции, равной отношению стоимости поставленного товара (итоговая сумма по счету-фактуре, включая установленный законом налог на добавленную стоимость) к стоимости других товаров на момент смешения или соединения. Покупатель хранит для продавца возникшую таким образом единичную или долевую собственность.

**8.6** Если стоимость предоставленного залога превышает стоимость требований продавца в общем более чем на 20 %, продавец обязуется по требованию покупателя вернуть тому избыточный залог по выбору продавца.

**8.7** Если совокупность действующих правовых норм не допускает договоренности об условиях перехода права собственности на товар, покупатель обязан предоставить продавцу другие соразмерные гарантии при получении товарного кредита.

## 9. Отправка, переход рисков

**9.1** Отправка осуществляется на риск покупателя. Риск всегда переходит на покупателя не позднее чем с момента отправления товара, даже если прочие услуги берет на себя продавец.

**9.2** Если отправка задерживается вследствие обстоятельств, не зависящих от продавца, риск переходит на покупателя в день уведомления о готовности к отправке. По письменной просьбе покупателя отправляемый товар страхуется продавцом за счет покупателя на случай ущерба при поломке, повреждении при транспортировке, пожаре и наводнении.

**9.3** Транспортная и прочая упаковка, за исключением палет, не принимается назад в соответствии с Законом об упаковке. Покупатель обязан осуществить утилизацию упаковки за собственный счет.

## 10. Средства производства

**10.1** Если покупатель предоставляет в распоряжение продавца средства производства (например, инструменты, формы), то они должны поставляться продавцу бесплатно. Продавец берет на себя ответственность за их поломку, удушение или неполный возврат и следующий из этого ущерб только в случае грубой халатности или умыселных действий. Данное положение не действует, если законом устанавливается обязательная ответственность.

**10.2** Когда средства производства изготавливаются или приобретаются продавцом по поручению покупателя, продавец включает в счет соответствующие издержки. Эти средства производства остаются в собственности продавца. Продавец не обязан выдавать их покупателю. Это относится также и к последовательным штампам. Изложенное ниже положение под пунктом 10.3 при этом сохраняет свою силу.

**10.3** В случае амортизации расходов на средства производства по цене детали, покупатель берет на себя не покрытые расходы при неамортизации инструмента, включая расходы на прочее типизированное оборудование. Затраты на модели всегда покрываются в полном объеме за счет покупателя.

**10.4** Запрещено передавать третьим лицам данные, выданные покупателем продавцом чертежи и документы, а также сообщать о предложениях продавца о конструировании и изготовлении товара. Данные чертежи и документы могут быть истребованы назад продавцом в любое время.

## 11. Ответственность за обнаруженные в изделии дефекты / ответственность

**11.1** Продавец не несет ответственности за ущерб, вызванный нарушением предписаний инструкций по эксплуатации, техническому обслуживанию и монтажу, использованием не по назначению или некачественным использованием, неправильным или небрежным обращением, естественным износом, неправильным хранением, или изменением товара продавцом или третьими лицами. Монтаж товара по поручению покупателя или третьих лиц должен выполняться только обученными специалистами.

**11.2** Выбор между устранением дефектов и поставкой нового товара делает продавец. По требованию продавца покупатель должен передать ему рекламизированный товар для анализа. В случае возникновения расходов вследствие непропорционального требования со стороны покупателя об устранении дефектов (в частности, расходом на испытания и транспортных расходов) продавец может потребовать возмещения этих расходов.

**11.3** Продавец не покрывает издержки, необходимые для устранения дефекта, если повышение издержек связано с перевозкой товара после поставки в иное место, чем исходное место поставки.

**11.4** Если требование к продавцу предъявляется покупателем в порядке регресса, после того как к самому покупателю были предъявлены претензии его клиентом за дефекты в изделии, то для реализации прав применяется § 445а Гражданского уложения Германии.

**11.5** Срок действия требований по ответственности за обнаруженные в изделии дефекты истекает через год с момента передачи товара, кроме случаев, когда требование устранения недостатков, обнаруженных в товаре, основано на неисполнении обязательств продавцом или лицом, действующим по поручению продавца, по грубой халатности или умыслу, или в случае ущерба жизни и здоровью, а также телесных повреждений. В случае претензий по гарантии отсутствия дефектов, которые предъявляются к продавцу покупателем в порядке регресса согласно § 445а Гражданского уложения Германии, в неограниченном объеме действует положение об исковой давности согласно § 445b Гражданского уложения Германии.

**11.6** Покупатель обязуется выполнить свою обязанность исследования товара при покупке согласно § 377 Торгового уложения, в том числе и в случае перепродажи товара.

**11.7** Исключается применение покупателем права регресса по отношению к продавцу в связи с такими требованиями устранения недостатков, выданными покупателем клиентам, если покупатель не выполнил свою обязанность исследования товара при покупке и обязанность немедленно извещать о претензиях к качеству товара, или если товар был изменен при переработке.

**11.8** Ответственность продавца за возмещение ущерба согласно положениям закона не ограничена, если вменяемое продавцу невыполнение обязанностей основано на умысле или грубой халатности. Если вменяемое продавцу невыполнение обязанностей основано на простой халатности, и виновно нарушены важные договорные обязательства, ответственность за возмещение ущерба ограничивается прогнозируемым ущербом, обычно возникающим в аналогичных случаях. В остальных случаях ответственность исключена.

**11.9** Возмещаются только упущенная прибыль и ущерб в связи с простым, которые вызваны умыселными действиями и грубой халатностью.

**11.10** Это не затрагивает ответственность согласно Закону об ответственности за продукцию или аналогичным неотъемлемым правам зарубежных законодательств. Сохраняется ответственность за ущерб, нанесенный жизни и здоровью, а также при телесных повреждениях.

**11.11** Если ответственность по фактам, указанным в пункте 11.9, обоснована, ответственность продавца по отношению к покупателю в рамках зарубежных законодательств ограничена пределами, допустимыми соответствующим зарубежным законодательством.

**11.12** Если ответственность продавца за возмещение ущерба исключена или ограничена, это распространяется и на личную ответственность за возмещение ущерба сотрудников, представителей и лиц, действующих по поручению продавца.

## 12. Запрещение переуступки

**12.1** Все требования покупателя по отношению к продавцу не подлежат переуступке.

**12.2** Продавец вправе в любое время, в том числе без согласия покупателя, привлекать связанные с ним предприятия (согласно § 15 Закона об акционерных обществах) в качестве лиц, действующих по поручению продавца, к выставлению предложений и выполнению договоров.

## 13. Ответственность за продукцию / обязанность давать указания

**13.1** Покупатель обязан использовать товар только по назначению и гарантировать перепродажу товара только лицам, ознакомленным с опасностями и рисками, связанными с продуктом.

**13.2** Покупатель обязуется давать соответствующие указания в случае использования товара в качестве основного материала и компонента собственных продуктов при сбыте конечного продукта, и относительно товара, поставленного продавцом. В рамках отношений партнеров по договору, покупатель освобождает продавца от предъявления претензий при нарушении этого обязательства по первому требованию.

## 14. Конфиденциальность

Покупатель обязан в отношении с третьими лицами обращаться со всей коммерческой и технической информацией, полученной от продавца, как с коммерческой и производственной тайной, кроме случаев, когда она общеизвестна. Подобная информация может быть передана третьим лицам, заключившим соглашение о конфиденциальности, только в целях, установленных договором.

## 15. Защита персональных данных

Продавец собирает, обрабатывает и использует персональные данные покупателя только при условии соблюдения действующих Положений о защите персональных данных. Согласно этим Положениям персональные данные покупателя используются только при наличии предусмотренного законом разрешения или согласия.

## 16. Прочее

**16.1** Местом исполнения является местонахождение соответствующего завода продавца.

**16.2** Местом судебного рассмотрения всех споров по данному договору является Хайльбронн. Однако продавец имеет право предъявить иск покупателю по месту его общей подсудности.

**16.3** При исполнении договора по данным условиям продажи и поставки действует исключительно германское законодательство, за исключением случаев применения коллизионного права и Конвенции ООН о договорах международной купли-продажи товаров (CISG).

**16.4** В рамках действия отношений по договору стороны обязуются выполнять все действующие положения закона.

**16.5** Если одно или несколько изложенных выше положений окажется полностью или частично недействительным, остальные положения сохраняют силу. Недействительное положение должно быть заменено на законно допустимое положение, максимально приближенное к смыслу и цели данных условий продажи и поставки.

- ٥-٨ إذا كانت البضائع المسلمة مختلطة أو مدمجة بشكل مع أصناف أخرى لا تخص البائع لا يمكن فصله، فإن البائع يكتسب ملكية مشتركة لهذه العناصر الجديدة أو المدمجة بنسبة قيمة البضائع المسلمة (مبلغ الفاتورة النهائية، بما في ذلك ضريبة القيمة المضافة) فيما يتعلق بكافة الأصناف التي جرى خلطها أو دمجها. ويحفظ المشتري بالملكية الزائدة أو المشتركة للبائع.
- ٦-٨ إذا تجاوزت قيمة الضمانات المقدمة لمطالبات البائع بأكثر من ٢٠٪، فإن البائع ملزم، بناءً على طلب المشتري، بتحرير الضمانات الزائدة وفقاً لتقدير البائع.
- ٧-٨ إذا لم يسمع النظم القانوني المعنى بالتوصل إلى اتفاق بشأن الاحتفاظ بحق الملكية، وإلى الحد الذي لا يسمح فيه بذلك، فإن المشتري يمدد البائع بالضمانات الأخرى المناسبة عند استخدام الائتمان التجاري.

**٩- الشحن ونقل المخاطر**

- ١-٩ الشحن يكون على مسؤولية المشتري. وتنتقل المخاطر إلى المشتري دائماً عند إرسال البضائع على أبعاد تقديري، حتى لو قَدِم البائع خدمات أخرى.
- ٢-٩ إذا تأخر الشحن بسبب ظروف لا يتحمل البائع مسؤوليتها، فإن المسؤولية تنتقل إلى المشتري من يوم الإبلاغ عن جاهزية الشحن. بناءً على طلب كتابي من المشتري، سيوفر البائع بالتأمين على الكسر والنقل والحرائق والأضرار الناجمة عن المياه على نفقة المشتري.
- ٣-٩ يتم إرجاع عيوب النقل وجميع العيوب الأخرى وفقاً لقانون التبعة، تستثنى من ذلك المنصات. يلتزم المشتري بالتخلص من العيوب على نفقته الخاصة.

**١٠ معدات الإنتاج**

- ١-١٠ إذا قام المشتري بإمداد البائع بمعدات الإنتاج (مثل الأدوات والقوالب)، فيجب إرسالها إلى البائع مجاًئاً. ولا يتحمل البائع مسؤولية خسارتها أو تدهور حالتها أو عدم اكتمال تسليمها والأضرار الناتجة عن ذلك إلا في حالات الإهمال الجسيم أو التعمد. ولا يطبق ذلك إذا كانت المسؤولية الزامية بموجب القانون.
- ٢-١٠ إذا قام البائع بتوصيف معدات الإنتاج أو شراؤها نيابة عن المشتري، فيقوم البائع بإرسال فاتورة إلى المشتري بالتكاليف بشكل منفصل. وتبقى معدات الإنتاج ملكاً للبائع. ولا يلتزم البائع بتسليمها للمشتري. وينطبق ما ورد أعلاه أيضاً على الأدوات اللائحة. ولا تتأثر اللائحة التالية الواردة في القسم ٣-١٠ بذلك.
- ٣-١٠ إذا تم تسديد نظير معدات الإنتاج من سعر قطع الغيار، ولم يتم تسديد سعر المعدات، فإن المشتري يتحمل التكاليف غير المغطاة، بما في ذلك مصروفات توفير المعدات الأخرى ذات الصلة بالبيع. يتحمل المشتري تكاليف النماذج دائماً بالكامل.
- ٤-١٠ يتم نقل الرسوم والمستندات التي يسلمها البائع إلى المشتري بالإضافة إلى اقتراحات البائع لتصميم وتصنيع البضائع إلى أطراف أخرى، ويجوز للبائع أن يطلب إعانتها في أي وقت.

**١١ المسؤولية عن العيوب المادية / المسؤولية**

- ١-١١ البائع غير مسؤول عن الأضرار التي تحدث نتيجة لانتهاك التعليمات التشغيل والصيانة والتزييب، أو الاستخدام غير المناسب أو غير السليم أو غير المطابق للتعليمات، أو التعامل غير الصحيح أو الإهمال، أو الهبلى الطبيعي، أو التخزين غير الصحيح أو التغييرات في البضائع التي أجراها المشتري في غيره من الأطراف. لا يُسمح للمشتري في الأطراف الأخرى بتركيب البضائع إلا بمعرفة موظفين متخصصين مدربين.
- ٢-١١ يحق للبائع الاختيار بين إصلاح المنتج أو تسليم منتج جديد. ويجب على المشتري تسليم البضائع المعنية إلى البائع بناءً على طلبه لفحصها. إذا تكبد البائع تكاليف (لا سيما تكاليف الاختبار والنقل) بسبب طلب المشتري غير المبرر لتصحيح عيب ما، فيمكن للبائع أن يطالب بسداد هذه التكاليف

- ٣-١١ لن يتحمل البائع النفقات اللازمة للوفاء بالحق المعقد إذا زانت النفقات بسبب نقل البضائع إلى موقع آخر غير موقع التسليم الأصلي بعد التسليم.
- ٤-١١ إذا رفع المشتري دعوى ضد البائع باستخدام حق الرجوع بعد أن تم رفع دعوى قضائية ضد المشتري نفسه من أحد عملائه بسبب وجود عيب، فإن المادة 445a من القانون المدني الألماني (BGB) تطبق على الإنقاذ القانوني.
- ٥-١١ تنتهي المطالبات الناشئة عن المسؤولية عن العيوب المادية بعد علم من تسليم البضائع، ما لم تكن مطالبات المسؤولية عن العيوب المادية مبنية على إهمال جسيم أو خرق متعمد للواجب من البائع أو وكيله الذي يوجب عنه أو على تضرر الحياة، أو إصابة الجسم أو الصحة في حالة المطالبات الخاصة بضمان العيوب التي يؤكدتها المشتري ضد البائع عن طريق حق الرجوع وفقاً للمادة 445a من القانون المدني الألماني (BGB)، تنطبق فترة التقادم المنصوص عليها في المادة 445b من القانون المدني الألماني (BGB) دون قيود.
- ٦-١١ يلتزم المشتري بلوفاء بالتزامه بالتحقق وفقاً للمادة ٣٧٧ من القانون التجاري الألماني (HGB) حتى عند إعادة بيع البضائع.
- ٧-١١ يُستبعد حق المشتري في الرجوع على البائع بسبب المطالبات الناشئة عن المسؤولية عن العيوب المادية التي يتم تأكيدها ضد المشتري من عملائه إذا لم يتم المشتري بلوفاء بالتزامه بالتحقق والإبلاغ عن العيوب أو إذا تم تعديل البضائع من خلال معالجتها.
- ٨-١١ إذا تم استخدام البضائع كإحدى الأجزاء غير معدودة إذا كان الإخلال بالواجب المنسوب إلى البائع قائماً على التعمد أو الإهمال الجسيم. إذا كان خرق الواجب المنسوب إلى البائع يستند إلى إهمال بسيط وتم انتهاك التزام تعاقدي أساسي، فإن المسؤولية عن الأضرار تقتصر على الضرر المتوقع الذي يحدث عادة في الحالات المماثلة. علاوة على ذلك، تستبعد المسؤولية.
- ٩-١١ يقتصر التعويض عن الأرباح المفقودة والأضرار الناجمة عن انقطاع الأعمال الناجم عن التعمد والإهمال الجسيم.
- ١٠-١١ تبقى المسؤولية بموجب أحكام قانون مسؤولية المنتج أو الحقوق الشبيهة التي لا غنى عنها، بما في ذلك الأنظمة القانونية الأجنبية، دون مساس. كما تبقى المسؤولية عن الأضرار التي تلحق بالحياة والجسم والصحة دون مساس.
- ١١-١١ إلى الحد الذي يتم فيه تحديد المسؤولية بناءً على الواقع الواردة في القسم ٩-١١، تكون مسؤولية البائع المنصوص عليها في القوانين الأجنبية، فيما يتعلق بالمشتري، محدودة بالحد الذي ينص عليه القانون الأجنبي المعنى.
- ١٢-١١ إلى الحد الذي يتم فيه استبعاد أو تقييد مسؤولية البائع عن الأضرار، ينطبق ذلك أيضاً فيما يتعلق بالمسؤولية الشخصية عن الأضرار التي تلحق بموظفي البائع وممثليه وكلاءه الموقّنين.

**١٢ حظر التنازل**

- ١-١٢ لا يمكن التنازل عن جميع مطالبات المشتري ضد البائع.
- ٢-١٢ يحق للبائع في أي وقت، حتى دون موافقة المشتري، أن يُشرك الشركات التابعة له (بالمعنى المقصود في المادة ١٥ من قانون الشركات المساهمة) بوصفهم وكلاء يوثبون عنه في إعداد العرض وتنفيذ العقد.

**١٣ التزامات المنتج/ واجب الإخطار**

- ١-١٣ لا يُسمح للمشتري باستخدام البضائع إلا على النحو المطبق للتعليمات ويجب عليه التأكد من عدم إعادة بيع هذه البضائع إلا للأشخاص الذين لديهم دراية بمخاطر المنتج والأخطار الناجمة عنه.
- ٢-١٣ عند استخدام البضائع كمادة خام وكجزء من منتج ما، يلتزم المشتري بالامتثال لالتزامه بالتحرير عند طرح المنتج النهائي في السوق، بما في ذلك ما يتعلق بالبضائع التي يسلمها البائع. في العلاقة الداخلية، يعنى المشتري البائع من تأكيد المطالبات في حالة انتهاك هذا الالتزام عند الطلب الأول.

**١٤- المسؤولية**

يجب على المشتري التعامل مع كافة المعلومات التجارية والتقنية الواردة عن البائع على أنها أسرار تجارية وأسرار تشغيلية تجاه أي أطراف أخرى، ما لم تكن معروفة بشكل عام. لا يُسمح بنقل هذه المعلومات إلا إلى أطراف أخرى ملزمة بتقافية حماية بيانات معينة ولغرض الوفاء بالعقد.

**١٥- حماية البيانات**

لا يقوم البائع بجمع ومعالجة واستخدام البيانات الشخصية للمشتري إلا بما يتوافق مع لوائح حماية البيانات ذات الصلة. وبناءً على ذلك، فإنه لن يستخدم البيانات الشخصية الخاصة بالمشتري إلا في حالة وجود تصريح أو موافقة قانونية.

**١٦- نقاط أخرى**

- ١-١٦ مكان التنفيذ هو موقع مصنع البائع المعنى.
- ٢-١٦ محل التقاضي لجميع النزاعات الناشئة عن العقد هو مدينة هيلبرون. ومع ذلك، يحق للبائع أيضاً مقاضاة المشتري في مقر محل التقاضي العام الخاص به.
- ٣-١٦ باستثناء لإبرام العقود بناءً على شروط البيع والتسليم هذه، ينطبق القانون الألماني حصرياً، باستثناء الأمور التي بها تنازع في القوانين واتفاقية الأمم المتحدة بشأن عقود البيع الدولي للبضائع (CISG).
- ٤-١٦ يلتزم الطرفان بالامتثال لجميع الأحكام القانونية المعمول بها عند تنفيذ العلاقة التعاقدية.
- ٥-١٦ إذا أصبح حكم أو أكثر من الأحكام المذكورة أعلاه غير فعال كلياً أو جزئياً، فإن صلاحية الأحكام المتبقية تبقى دون مساس. ويجب عندئذ استبدال الحكم غير الساري بأخر سارٍ قانوناً ويحقق المعنى والغرض من شروط البيع والتسليم هذه بطريقة شبيهة بقدر الإمكان.

- ١- نطاق السريان**
- ١-١ تنطبق شروط البيع والتسليم الخاصة بشركة MS Motorservice International GmbH (المشار إليها فيما يلي "البائع") حصرياً. ومن ثم، إن يتم الاعتراف بشروط المشتري التي تتعارض أو تحيد عن شروط البيع والتسليم هذه إلا إذا وافق البائع كتابياً وبشكل واضح على صحة هذه الشروط المخالفة. تنطبق شروط البيع والتسليم هذه أيضاً إذا قام البائع بالتوريد إلى المشتري دون أي تحفظ على الرغم من علمه بشروط المشتري التي تتعارض أو تحيد عن شروط البيع والتسليم الخاصة بالمشتري.
- ٢-١ تكون الأولوية للاتفاقيات المنفصلة بين الطرفين والتي تتحرف عن شروط البيع والتسليم هذه أو تستكملها. ما لم يتم وضع قواعد خاصة، سيتم استكمالها بشروط البيع والتسليم هذه. جديرٌ بالذكر أن العقد المكتوب أو التأكيد الكتابي من البائع يعتبر حاسماً بالنسبة لمحتوى هذه الاتفاقيات.
- ٣-١ تنطبق شروط البيع والتسليم أيضاً على كافة المعاملات المستقلة مع المشتري. بموجب تقديم المشتري لطلب، وحتى قبول البائع على أبعاد تقديري، يكون المشتري قد وافق على شروط البيع والتسليم هذه.
- ٤-١ تنطبق شروط البيع والتسليم هذه على الشركات فقط.

**٢- العرض وتأكيد الطلب**

- ١-٢ العروض التي يقدمها البائع غير ملزمة دائماً. فإذا كان طلب المشتري مؤهل قانوناً ليتمل عرضاً، فإنه لن يعتبر مقبولاً إلا إذا أكد البائع كتابياً في غضون أربعة أسابيع، يتم إبرام العقد عند إرسال البضائع المطلوبة أو عند توفير البضائع المطلوبة على أبعاد تقديري في حالة التسليم الجزئي، يكون العقد مُبرماً عند إرسال الفاتورة الأولى.
- ٢-٢ التغييرات والاتفاقيات الأخرى لا تكون ملزمة إلا إذا أكدها البائع كتابياً.
- ٣-٢ المستندات والرسومات ومعلومات الوزن والقياس والميزان وما إلى ذلك، الواردة في العروض تعتبر معلومات تقريبية فحسب ولا تمثل أي خصائص للحمولة. يحق للبائع الحيود عن الأوصاف الواردة في العرض، بشرط ألا تكون هذه الاختلافات جوهرية أو أساسية ولا تضر بالعرض التعاقدية بشكل كبير.
- ٤-٢ إذا تم تصنيع البضائع وفقاً لرسومات المشتري، فإن الرسومات التي أعدها المشتري ووافق عليها البائع تكون هي الحاسمة. يجب الاتفاق على وجه التحديد على الاختلافات عن الرسومات المعتمدة ويجب سداد أي مصروفات إضافية ناجمة عن ذلك إلى البائع.

**٣- حقوق الملكية**

- ١-٣ يحفظ البائع بحقوق الملكية وحقوق الطبع والنشر فيما يتعلق بكافة الرسومات التوضيحية والرسومات والحسابات وغيرها من المستندات؛ ولا يُسمح باستخدامها لأغراض أخرى غير تلك التي جدها البائع أو ابتناها لأي أطراف أخرى دون الحصول على موافقة كتابية مسبقة من البائع. وينطبق ذلك بشكل خاص على المستندات المكتوبة التي تم تصنيفها على أنها "سرية" أو "خاصة" أو ما شابه ذلك.
- ٢-٣ البائع غير مسؤول إلا عن المطالبات التي تنشأ عن انتهاك حقوق الملكية وتسجيلات حقوق الملكية (حقوق الملكية) عند استخدام البضائع وفقاً للعقد، والتي يندرج أحدها على الأقل في حقوق الملكية ما عن طريق النشر بمعرفة مكتب براءات الاختراع الأوروبي أو في إحدى جمهوريات ألمانيا الاتحادية أو فرنسا أو بريطانيا العظمى أو النمسا أو الصين أو اليابان أو الولايات المتحدة الأمريكية.
- ٣-٣ إذا تم تسليم بناءً على رسومات أو معلومات أخرى مقدمة من المشتري وترتب عن ذلك انتهاك حقوق ملكية طرف آخر، فيجب على المشتري تعويض البائع داخلياً عن جميع المطالبات.

**٤- التوصيات والمعلومات والبيانات**

التوصيات والمعلومات والبيانات لا تعتبر ملزمة إلا إذا كانت تتعلق بالبضائع نفسها.

**٥- الأسعار**

- ١-٥ جميع الأسعار تشير إلى الأسعار الصافية وتسري على "تسليم المصنع" (EXW - Incoterms@2020) باستثناء التعليف والشحن والبريد وتأمين القيمة. تصاف ضريبة المبيعات القانونية بقميتها السارية.
- ٢-٥ قد يُرسل البائع فاتورة بأي مصروفات إضافية ناجمة عن طيات التغيير إلى المشتري.
- ٣-٥ إذا حدثت أي تغييرات بعد إبرام العقد أتى إلى زيادة تكلفة شراء وإنتاج و/أو شحن البضائع للبائع، فيحق للبائع زيادة السعر المتفق عليه وفقاً لذلك.

**٦- شروط الدفع**

- ١-٦ تصيب الفواتير مستحقة الدفع دون أي خصومات خلال ١٤ يوماً من تاريخ الفاتورة. ويحق للبائع في أي وقت، حتى في إطار علاقة العمل المستمر، تنفيذ التتبعات كلياً أو جزئياً نظير الدفعة المقدمة فقط. ولا يطبق الخصم إلا إذا تم الاتفاق عليه صراحةً بصيغة كتابية.
- ٢-٦ يحق للبائع إجراء مقاصة مبدئية للمدفوعات نظير الدينون القديمة غير المصنفة، حتى لو كان غرض المشتري مخالفاً لذلك. إذا تكبد البائع تكاليف أو فوائد بالفعل، فيحق له تعويض المدفوعات أو لا بقيمة هذه التكاليف، ثم نظير الفائدة وأخيراً نظير الخدمة الرئيسية.
- ٣-٦ لا يحق للمشتري التعويض إلا إذا كانت مطالباته المعنية قد تم إثباتها قانونياً أو كانت غير متنازع عليها أو إذا اعترف بها البائع كتابياً وإلى الحد الذي تكون فيه هذه المطالبات سارية قانوناً. يقتصر حق المشتري في الاحتفاظ بالحق في المطالبات الناشئة عن العلاقة التعاقدية.
- ٤-٦ يحق للبائع تحصيل الفائدة الافتراضية بمعدل الفرض القانوني المعمول به. ويبقى الحق في إثبات الأضرار الأعلى الناجمة عن التأخير محفوظاً.

**٧- التوريد / وقت التسليم / التأخير**

- ١-٧ لا تعتبر فترات التسليم وتواريخ التسليم ملزمة إلا إذا وافق عليها البائع صراحةً في صيغة كتابية. لا يلتزم البائع بتاريخ التسليم أو فترة التسليم إذا لم يف المشتري بالتزاماته في الوقت المناسب (تحرير الدفعات المقدمة، وتوفير المستندات اللازمة، وإثابة الإنتاج، وما إلى ذلك). ويبقى الحق في معارضة العقد غير المكتمل محفوظاً.
- ٢-٧ تبدأ فترات التسليم في أقرب وقت من اليوم الذي تم فيه إبرام العقد كتابياً وتم توضيح جميع الأسئلة الفنية.
- ٣-٧ إذا طلب المشتري إجراء تغييرات، فيكون البائع معيّناً من الالتزام بأي تاريخ تسليم أو بفترة التسليم المتفق عليها. وفي هذه الحالة، يتفق الطرفان على مهلة أو موعد نهائي جديد للتسليم.
- ٤-٧ ما لم يتم الاتفاق على خلاف ذلك، يكون تاريخ التسليم أو مهلة التسليم مستوفاه إذا وُفّر البائع البضائع في الموقع المتفق عليه.
- ٥-٧ لا يمكن للمشتري تأكيد أي مطالبات بسبب التأخير في التسليم والتي لا تكون بسبب التعمد أو الإهمال الجسيم من طرف البائع. وينطبق ذلك أيضاً على الاختلالات الأخرى، ولا سيما تأخير التسليم بسبب القوة القاهرة، والنزاعات المالية، والإضرابات، والأوبئة و/أو الجوائح، والهجمات السيبرانية، والتدابير الحكومية، وعدم التسليم من الموردين وغيرها من الأحداث الخطيرة وغير المتوقعة والتي لا يمكن تجنبها. في هذه الحالات، سيتم تأجيل تاريخ التسليم أو مهلة التسليم المتفق عليها بحسب مدة وجود عائق التسليم، وسيقوم البائع بإبلاغ المشتري بذلك وسيقدم، إن أمكن، تاريخ تسليم متوقع جديد. يقتصر التعويض عن الأرباح المفقودة والأضرار الناجمة عن انقطاع الأعمال عمداً.
- ٦-٧ إذا أخفق المشتري في الفول أو انتهك التزامات التعاون الأخرى، فيحق للبائع المطالبة بالتعويض عن الضرر الناتج، بما في ذلك أي نفقات إضافية. ويحق للبائع أيضاً تحديد فترة قبول معقولة للمشتري، وإذا انتهت هذه الفترة، يحق له إلغاء العقد والمطالبة بالتعويض بدلاً من تنفيذ العقد.
- ٧-٧ يُسمح بالتسليم الجزئي إلى حد معقول. وفي ذلك الصدد، تستثنى مطالبات المشتري بسبب التسليم الجزئي أو التأخر في تسليم الكمية المتبقية.

**٨- الاحتفاظ بالملكية**

- ١-٨ يحفظ البائع بملكية كافة البضائع المسلمة حتى استلام كافة المدفوعات من علاقة التسليم، بما في ذلك الالتزامات المستقبلية. في حالة الإخلال بالعقد، وخاصة التأخر في السداد، يحق للبائع المطالبة بإعادة البضائع.
- ٢-٨ يلتزم المشتري بمعاملة البضائع المسلمة إليه بحرص وتأمينها على نفقته الخاصة ضد أي شكل من أشكال خسارة سعر الشراء طوال مدة الاحتفاظ بحق الملكية. ويبقى الحق مكتولاً للبائع في التأمين على البضائع بنفسه على نفقة المشتري.
- ٣-٨ في حالة مصادرة البضائع أو في حالة أي تدخلات أخرى من أطراف ثالثة، يجب على المشتري إخطار البائع كتابياً وعلى الفور حتى يتمكن البائع من تقديم مطالبات اعتراض تجاه الطرف الثالث أو يستخدم مبلغ الانصاف القانونية الأخرى. إذا لم يتم الطرف الثالث بسداد التكاليف القانونية وغير القضائية الناتجة، يكون المشتري مسؤولاً عن هذه التكاليف بنفسه.
- ٤-٨ يحق للمشتري إعادة بيع البضائع في سياق العمل العادي؛ ومع ذلك، فإنه يتنازل للبائع عندئذ عن جميع المطالبات بما يصل إلى مبلغ التكاليف القانونية وغير القضائية الناتجة، يكون المشتري مسؤولاً عن هذه التكاليف بنفسه.
- ٥-٨ الفاتورة النهائية (بما في ذلك ضريبة المبيعات القانونية) الخاص بالمطالبة التي تنشأ عن إعادة البيع إلى عملائه أو إلى أطراف ثالثة، بغض النظر عما إذا تمت إعادة بيع البضائع دون معالجتها أو بعد معالجتها، ويبقى الحق مكتولاً للمشتري في تحصيل هذه المطالبات حتى بعد التسليم. ولا تتأثر سلطة البائع في تحصيل هذه المطالبات بنفسه.



**MS Motorservice International GmbH**

Wilhelm-Maybach-Straße 14-18

74196 Neuenstadt, Germany

Telefon: +49 7139 9376-3333

Telefax: +49 7139 9376-2864

info@ms-motorservice.com

**www.ms-motorservice.com**



4 028977 895159

